

Application Note

GreenPAK based AC-Power Phase Cut Control with System Monitoring Features

AN-CM-305

Abstract

This application note describes a GreenPAK™ based solution to control AC-Power with a phase cut logic along with system monitoring features. A push button controls 2 phase delays programmed on-chip at hardware level, and an I2C compatible MCU modifies the phase delays at software level via I2C. The solution can be expanded to include more programmed delays for hardware control and additional system monitoring features.

GreenPAK based AC-Power Phase Cut Control with System Monitoring Features

Contents

Abstract	1
Contents	2
Figures	2
Tables	3
1 Terms and Definitions	4
2 References	4
3 Introduction	5
4 Zero-Crossing Circuit	5
5 GreenPAK Design	7
5.1 Hardware Control	8
5.2 Software Control	8
5.3 System Monitoring Features	9
5.3.1 Over Temperature Protection	10
5.3.2 Emergency Shutdown.....	11
5.3.3 Watchdog Timer	11
5.3.4 Frequency Detector	12
5.4 Modifying the Phase Delay	13
6 TRIAC Driver Circuit	13
7 Testing	14
8 Feature Extension	14
9 Demonstration PCB	16
10 Conclusion	17
Revision History	18

Figures

Figure 1: Phase Cut Output.....	5
Figure 2: Opto-isolator with Phototransistor	6
Figure 3: Zero-Crossing Circuit Waveforms	6
Figure 4: GreenPAK Design	7
Figure 5: Hardware Control Waveforms.....	8
Figure 6: Software Control Waveforms	9
Figure 7: OTP Schematic	10
Figure 8: OTP Waveforms.....	10
Figure 9: Emergency Shutdown	11
Figure 10: Watchdog Timer	12
Figure 11: Frequency Detector.....	12
Figure 12: Photo-TRIAC Opto-isolator	13
Figure 13: Phase Cut Test Schematic.....	14
Figure 14: Software Control Phase Cut Output.....	15
Figure 15: Hardware Control Phase Cut Output	15
Figure 16: DA14531 USB Development Kit based Test Schematic	16
Figure 17: Phase Cut and Cycle Skip PCB.....	16

**GreenPAK based AC-Power Phase Cut Control with
System Monitoring Features**

Tables

Table 1: CNT0/DLY0 I2C Address 13

GreenPAK based AC-Power Phase Cut Control with System Monitoring Features

1 Terms and Definitions

AC	Alternating Current
ACMP	Analog Comparators
I2C	Inter-Integrated Circuit Serial Communication
LED	Light Emitting Diode
LUT	Look Up Table
OTP	Over Temperature Protection
PCB	Printed Circuit Board
SCR	Silicon Controlled Rectifier
TRIAC	Triode for Alternating Current

2 References

For related documents and software, please visit:

<https://www.dialog-semiconductor.com/greenpak>

Download our free [GreenPAK Designer Software](#) [1] to open the .gp files [2] and view the proposed circuit design. Use the [GreenPAK Development Tools](#) [3] to freeze the design into your own customized IC in a matter of minutes. Find out more in complete library of application notes [4] featuring design examples as well as explanations of features and blocks within the GreenPAK IC.

- [1] [GreenPAK Designer Software](#), Software Download and User Guide
- [2] [AN-CM-305, GreenPAK based AC-Power Cycle Skip Control with System Monitoring Features, GreenPAK Design File](#)
- [3] [GreenPAK Development Tools](#), [GreenPAK Development Tools Webpage](#)
- [4] [GreenPAK Application Notes](#), [GreenPAK Application Notes Webpage](#)
- [5] [SLG46855](#), Datasheet

Author: Krupa Bhavsar

GreenPAK based AC-Power Phase Cut Control with System Monitoring Features

3 Introduction

Most home-based electrical appliances generally use AC power for operation. Phase cut logic can be used in appliances such as AC dimmers and light bulbs. These electrical appliances consist of power electronic switches like Silicon Controlled Rectifier (SCR)s, and Triode for Alternating Current (TRIAC)s which are turned ON/OFF periodically to achieve smooth operation.

In this control, the load is turned ON for a portion of half cycle and is turned OFF for a portion of half cycle. This phenomenon of turning ON for a portion of a cycle reduces the overall power consumption. [Figure 1](#) displays the phase cut logic output. As shown in [Figure 1](#), the load is turned ON for a fraction of a cycle in each direction and is turned OFF for a part of a cycle in each direction. The load is completely turned OFF at each zero-crossing due to the property of TRIACs which is described in detail in [0](#).

Channel 1 (blue/top line) - AC Supply

Channel 2 (green/bottom line) - Phase Cut Output

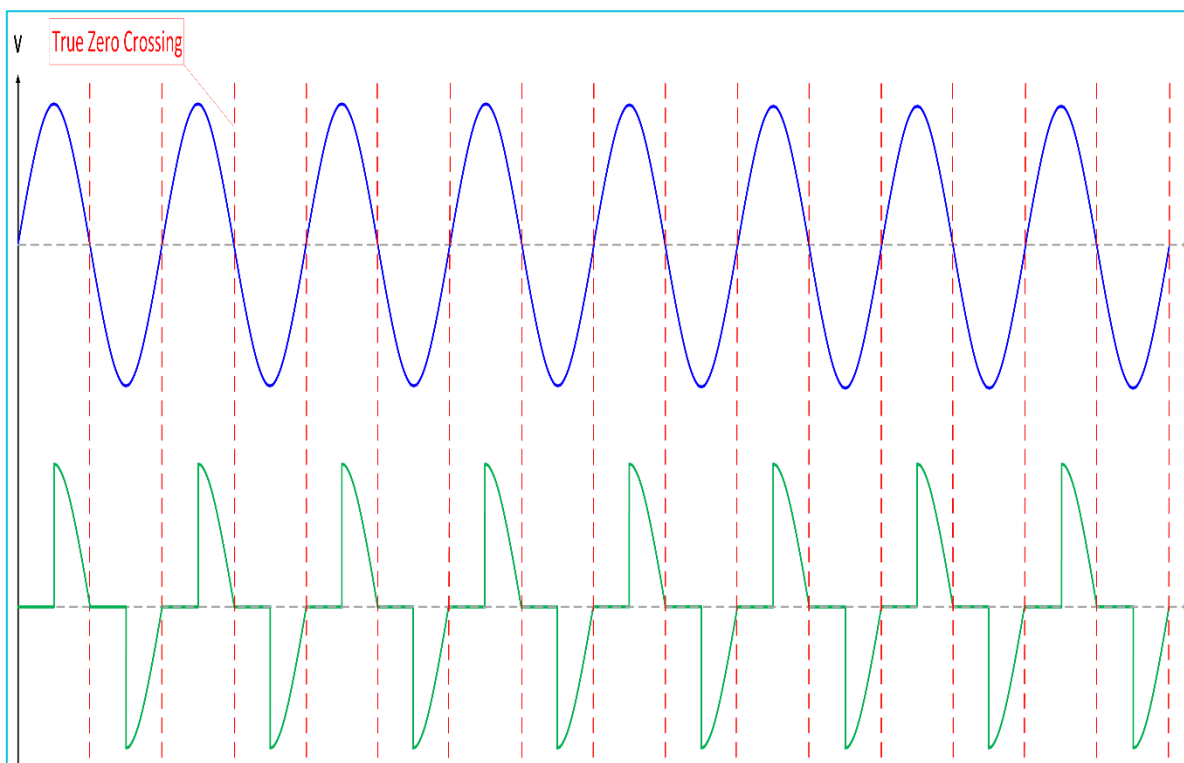

Figure 1: Phase Cut Output

This application note is divided into 3 sections. [4](#) describes a zero-crossing circuit, [5](#) illustrates the generation of different phase delays including system monitoring features using [GreenPAK \[4\]](#), and [0](#) defines a TRIAC driver circuit for driving the load.

4 Zero-Crossing Circuit

A zero-crossing circuit consists of an AC power supply, a half-wave rectifier, and an opto-isolator with a photo-sensitive device - phototransistor. The opto-isolators isolate AC and DC signals using light. This opto-isolator consists of a LED, a light beam, and phototransistor as shown in [Figure 2](#). The half-wave rectifier rectifies the HIGH voltage AC input and feeds the rectified output to the input LED of the opto-isolator. The signal from the LED then travels with an intensity proportional to the input signal, and falls onto the base of the phototransistor which in turn triggers the phototransistor to the ON state. The output of the phototransistor is a DC signal, which is used for generating different patterns in [GreenPAK](#).

GreenPAK based AC-Power Phase Cut Control with System Monitoring Features

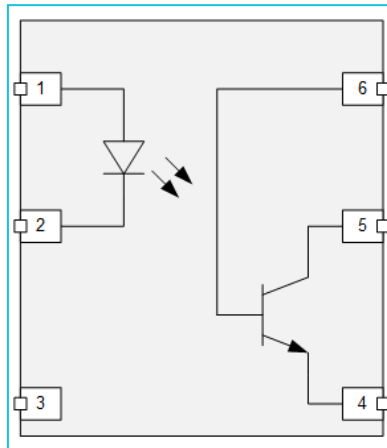

Figure 2: Opto-isolator with Phototransistor

Figure 3 displays the zero-crossing circuit waveforms. As seen in Figure 3, the DC signal at the phototransistor output is triggered before and after the true zero-crossing. The true zero-crossing is defined as the exact time when the AC signal reaches a zero voltage. This time shift is compensated inside the GreenPAK and the phase delays are adjusted accordingly.

- Channel 1 (blue/top line) - AC Supply
- Channel 2 (green/2nd line) - Half Wave Rectifier Output
- Channel 3 (yellow/bottom line) - Opto-Isolator Output

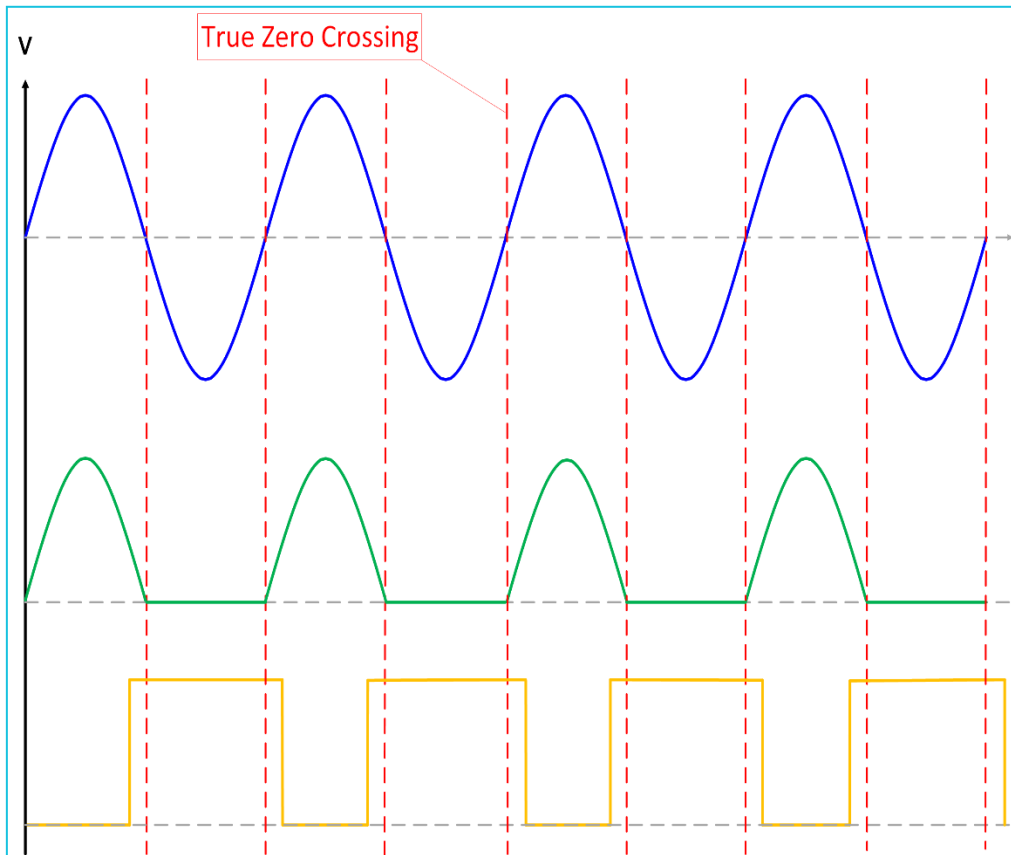

Figure 3: Zero-Crossing Circuit Waveforms

GreenPAK based AC-Power Phase Cut Control with System Monitoring Features

5 GreenPAK Design

Figure 4 reveals the GreenPAK Design for generating various phase delays for driving the load along with system monitoring features. This GreenPAK design can be used worldwide as it supports both 50Hz and 60Hz AC frequencies. This design includes both controls (i.e. hardware and software).

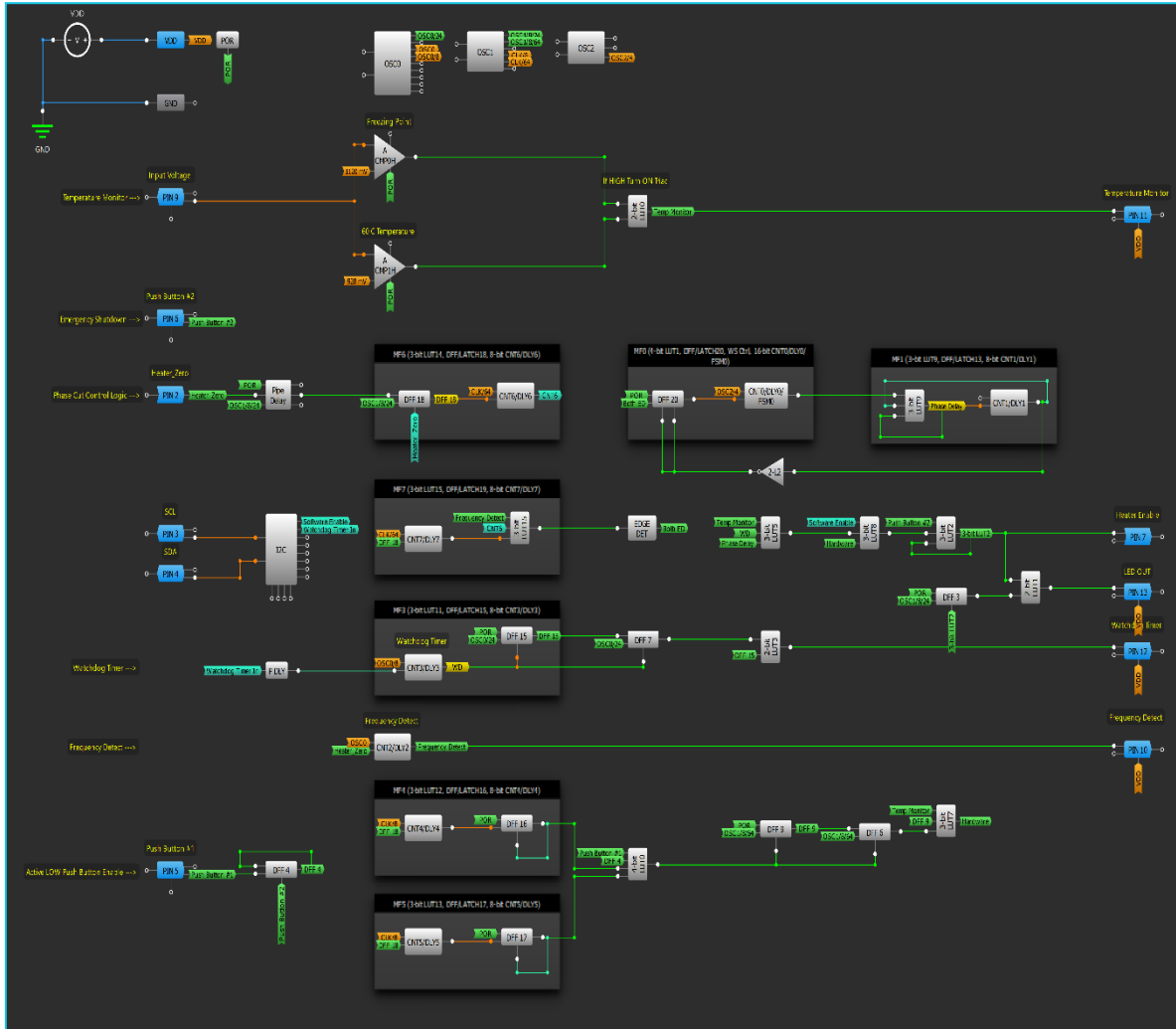

Figure 4: GreenPAK Design

The phototransistor output of the zero-crossing circuit arrives at Heater_Zero (Pin 2) of GreenPAK. As shown in Figure 3, the DC signal at the phototransistor output is triggered ON before the high voltage AC signal reaches its true zero-crossing. So, the rising edge of the phototransistor output is delayed internally, and the pulse width of the input signal is calculated based on the frequency of the input signal i.e. 50Hz and 60Hz.

5.1 describes the hardware control, 5.2 illustrates the software control, and 5.3 depicts the system monitoring features. After the phase delays are generated, they are then routed and displayed on Heater_Enable (Pin7). This Heater_Enable (Pin 7) is then connected to the TRIAC driving circuit for driving the load.

GreenPAK based AC-Power Phase Cut Control with System Monitoring Features

5.1 Hardware Control

The hardware control technique requires an external active LOW push-button and is connected to Push_Button #1 (Pin 5) on GreenPAK.

CNT4/DLY4 (3ms) and CNT5/DLY5 (5ms) are used to program 2 phase delays on-chip. Each phase delay has 8-bit resolution and is user selectable. These phase delays are compatible with both input frequencies i.e. 50Hz and 60Hz. Alternate toggle of the push button displays the same phase delay on the Heater_Enable (Pin 7) only when the system monitoring features - Over Temperature Protection (OTP) and Emergency Shutdown, are in range.

Figure 5 exhibits the hardware control waveforms. As seen in Figure 5, a zero-crossed AC signal arrives at Heater_Enable (Pin 2), and at each alternate button press (Push Button #1 - Pin 5) the same phase delay is propagated on the Heater_Enable (Pin 7). The Heater_Enable (Pin 7) is held LOW when the button is released or when the system monitoring features are out of range.

Channel 1 (yellow/top line) – PIN#9 (Input Voltage)

Channel 2 (blue/2nd line) – PIN#7 (Heater_Enable)

D0 – PIN#6 (Push Button #2)

D1 – PIN#5 (Push Button #1)

D2 – PIN#2 (Heater_Zero)

D3 – PIN#11 (Temperature Monitor)

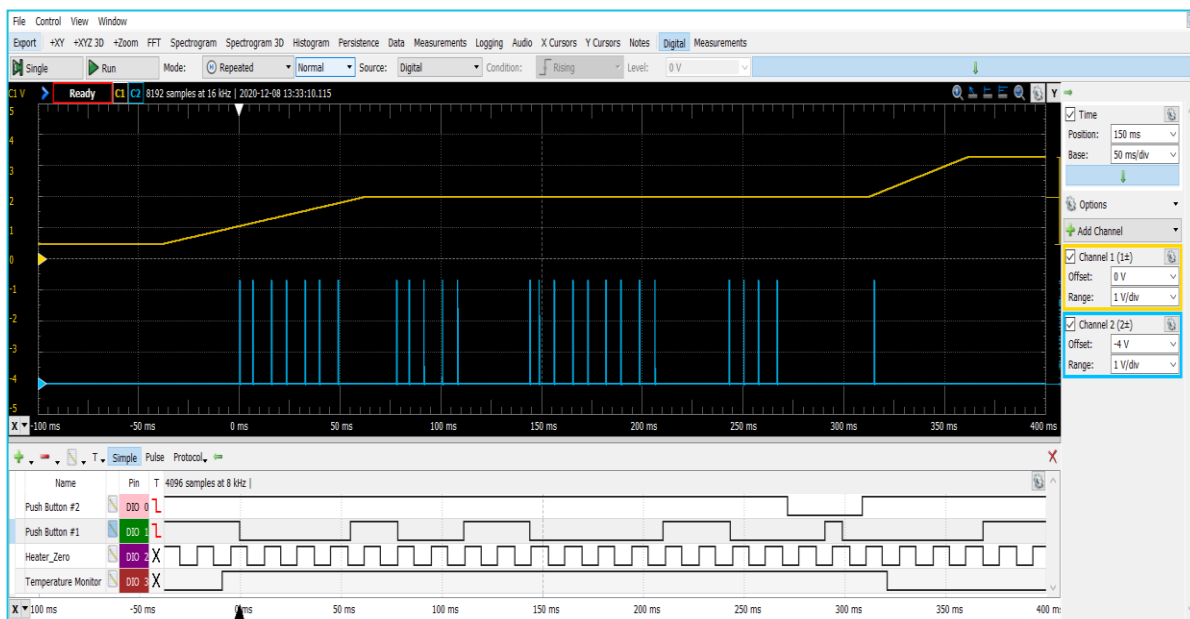

Figure 5: Hardware Control Waveforms

5.2 Software Control

The software control operates through an I2C communication from an external I2C compatible MCU.

In this control, the control data register of CNT0/DLY0 (16-bit resolution) is modified via I2C. After an appropriate phase delay is written through I2C, the phase delay is routed and displayed on Heater_Enable (Pin 7), as long as all the system monitoring features - Emergency Shutdown, OTP, and Watchdog Timer are in range. 5.4 defines the recommended steps to modify the CNT0/DLY0 control data register via I2C.

Figure 6 reveals the software control waveforms. As shown in Figure 6, the phase delay is only displayed on Heater_Enable (Pin 7) when Software Enable is HIGH and all system monitoring features are in range.

GreenPAK based AC-Power Phase Cut Control with System Monitoring Features

5.3 System Monitoring Features

OTP, Emergency Shutdown, Watchdog Timer, and Frequency Detector are the system monitoring features included in this GreenPAK design.

Channel 1 (yellow/top line) – PIN#9 (Input Voltage)

Channel 2 (blue/2nd line) – PIN#7 (Heater_Enable)

D0 – PIN#6 (Push Button #2)

D1 – I2C Virtual Input 0 - OUT0 (Software Enable)

D2 – PIN#2 (Heater_Zero)

D3 – PIN#11 (Temperature Monitor)

D4 – I2C Virtual Input 1 - OUT1 (Watchdog Timer In)

D5 – PIN#12 (Watchdog Timer)

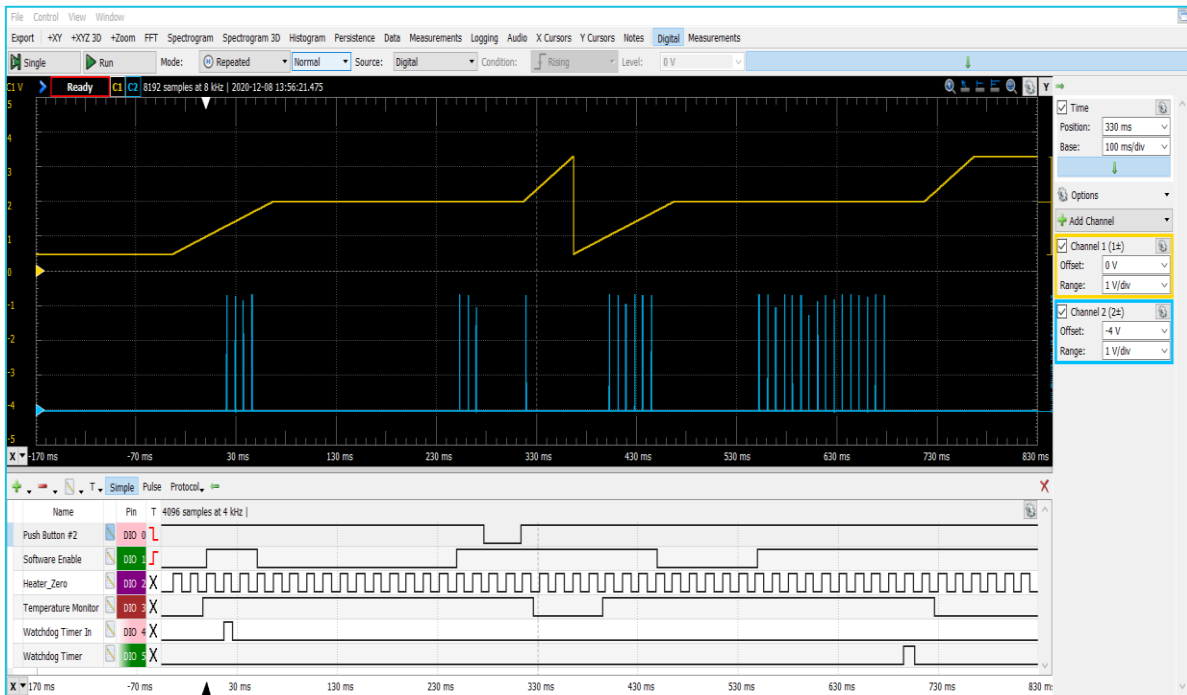

Figure 6: Software Control Waveforms

GreenPAK based AC-Power Phase Cut Control with System Monitoring Features

5.3.1 Over Temperature Protection

OTP feature is available in both hardware and software control techniques. This feature requires an external resistor divider with a thermistor. A thermistor is a temperature dependent resistor, whose resistance decreases with increase in temperature.

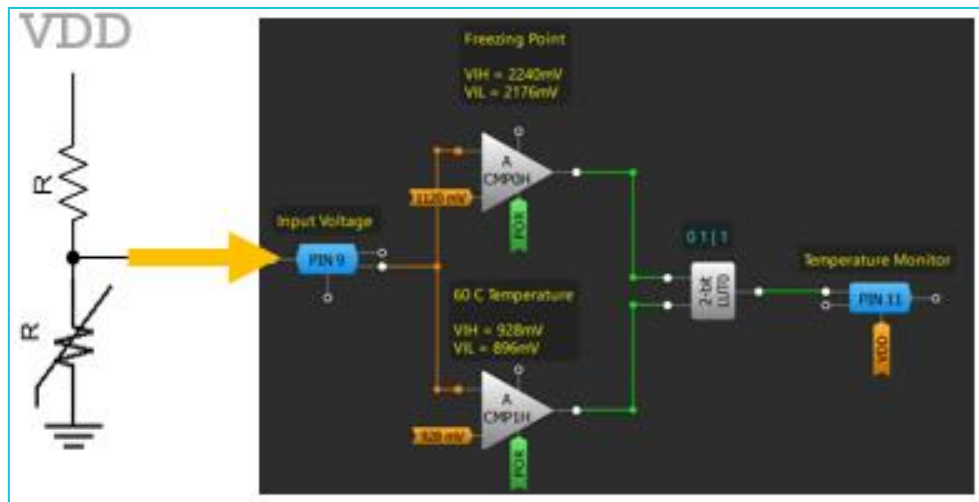

Figure 7: OTP Schematic

Figure 7 shows the OTP schematic. The sensed voltage is connected to Input Voltage (PIN 9) on GreenPAK. The temperature range inside GreenPAK is accomplished with a set of 2 Analog Comparators (ACMPs) and a LUT. In this design, the operational temperature range is set from 0°C to 60°C, which respectively corresponds to a voltage range from 2.176V to 0.928V for ACMPs. When the temperature is out of range the system is OFF, and when the temperature is in range, the design functions according to the chosen user control, i.e. hardware or software.

Figure 8 displays the OTP waveforms. As seen in Figure 8, the temperature monitor output is HIGH when the temperature is in range, and the output is LOW when the temperature is out of range.

Channel 1 (yellow/top line) – PIN# 9 (Input Voltage)

Channel 2 (blue/bottom line) – PIN# 11 (Temperature Monitor)

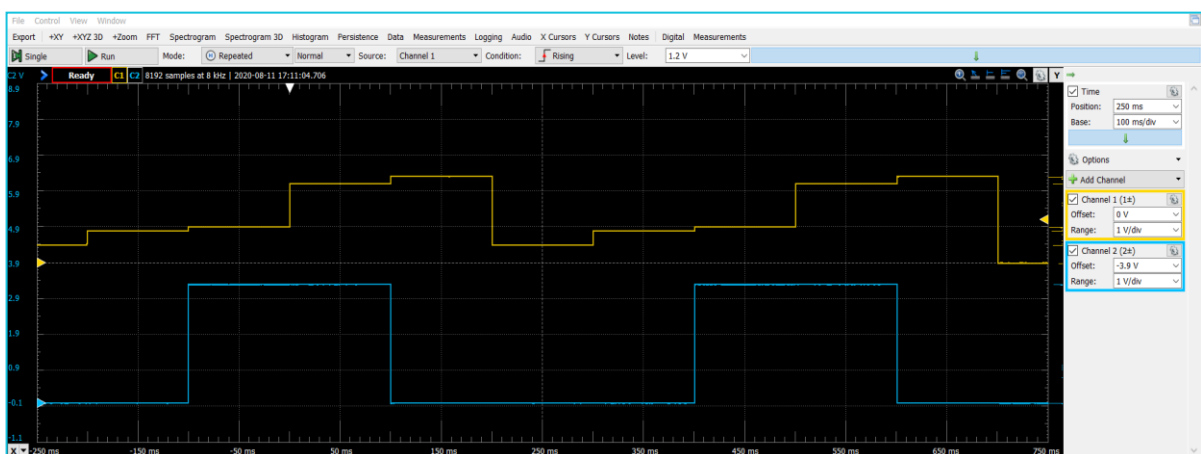

Figure 8: OTP Waveforms

GreenPAK based AC-Power Phase Cut Control with System Monitoring Features

5.3.2 Emergency Shutdown

Emergency shutdown has the highest priority and this feature is available for both hardware and software control techniques. This feature is accomplished with an external active LOW push button which is connected to Push Button #2 (Pin 6) on GreenPAK IC. When the button is pressed the Heater_Enable (Pin 7) output goes LOW and the system turns OFF. When the button is released, the system turns back ON depending upon software or hardware control and if other system monitoring features are in range.

Channel 1 (yellow/top line) – PIN# 6 (Push Button #2)

Channel 2 (blue/bottom line) – PIN# 7 (Heater_Enable)

D0 – PIN# 2 (Heater_Zero)

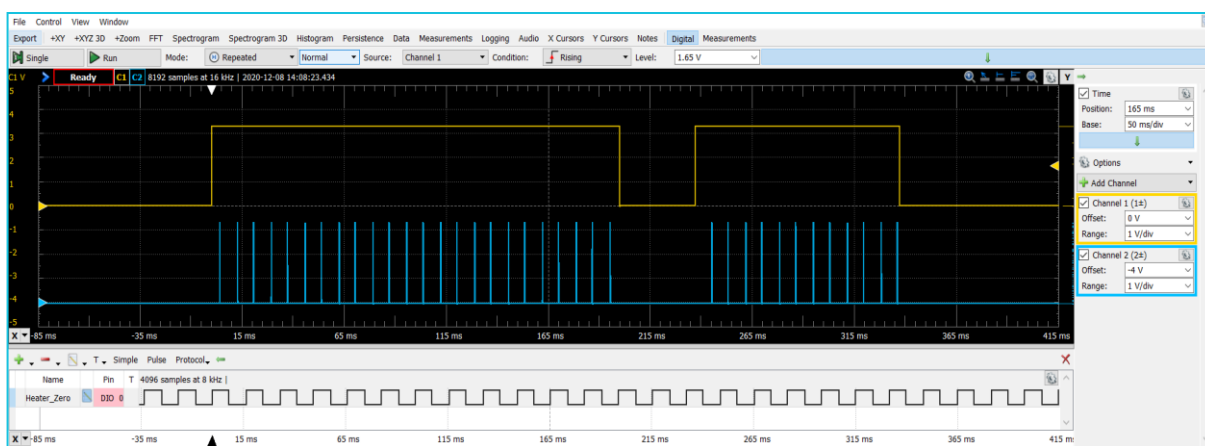

Figure 9: Emergency Shutdown

Figure 9 depicts the emergency shutdown feature. As shown in Figure 9, when the button is pressed the output at Heater_Enable (Pin 7) goes LOW.

5.3.3 Watchdog Timer

This feature is available in software control only and is controlled through an I2C compatible MCU. CNT3 (8-bit) sets the period of the watchdog timer. At POR, CNT3 is loaded with a period determined by its control data register, which is 656.25ms (default). The timer operates continuously through a toggled I2C Virtual Input 1 - OUT1. If the MCU freezes or the I2C Virtual Input 1 - OUT1 is toggled after the default set time, then the timer expires after 656.25ms and produces a reset pulse at watchdog timer (Pin 12). When the timer expires, the Heater_Enable (Pin 7) goes LOW and the system turns OFF. The timer period is user selectable and can be changed through I2C.

Channel 1 (yellow/top line) – (I2C Virtual Input 1 - OUT1)

Channel 2 (blue/bottom line) – (CNT3 Output)

D0 – PIN# 12(Watchdog Timer)

GreenPAK based AC-Power Phase Cut Control with System Monitoring Features

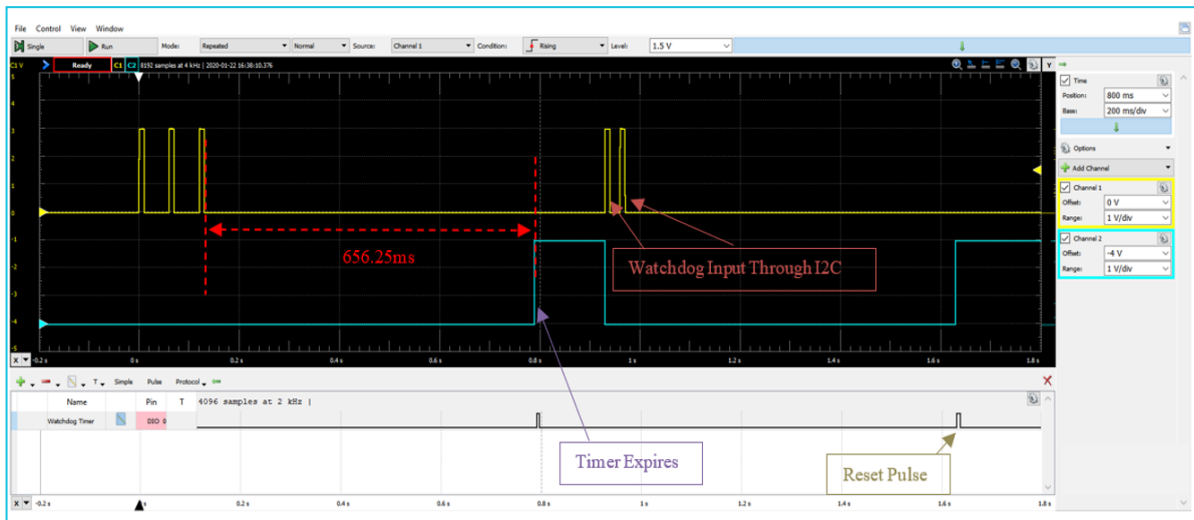

Figure 10: Watchdog Timer

Figure 10 shows the watchdog timer waveforms. As shown in Figure 10, when the I2C Virtual Input 1 - OUT1 is toggled before 656.25ms, the watchdog timer output goes LOW and indicates the timer is in range. When the I2C Virtual Input 1 - OUT1 is toggled after the default time of CNT3, then the timer expires after 656.25ms (default) and the watchdog timer output produces a reset pulse.

Channel 1 (yellow/top line) – PIN# 2 (Heater_Zero)

Channel 2 (blue/bottom line) – PIN# 10 (Frequency Detect)

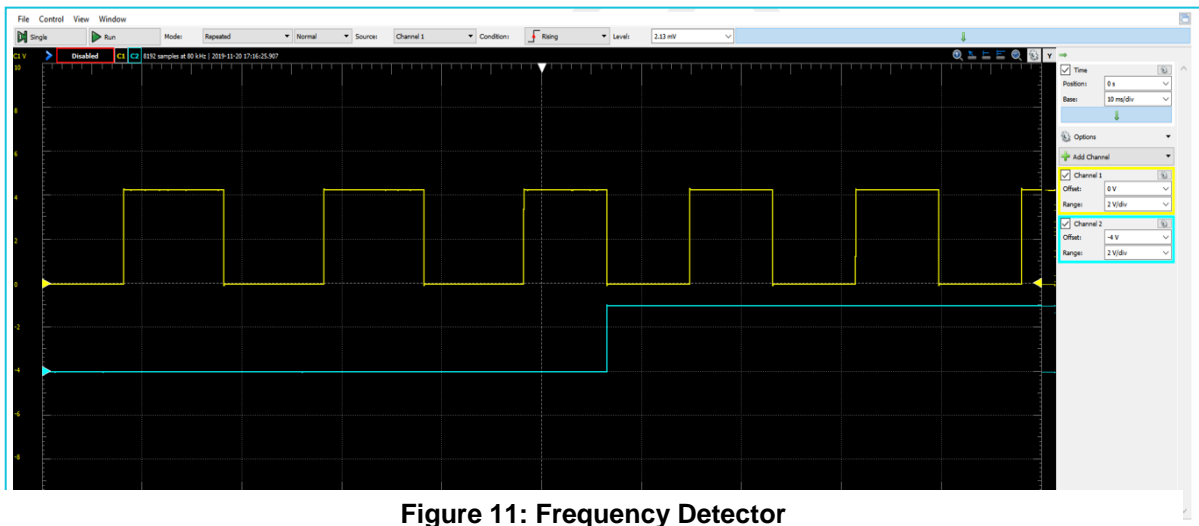

Figure 11: Frequency Detector

5.3.4 Frequency Detector

CNT2 is used to detect the frequency of the input signal. The frequency detect output is HIGH when a consecutive edge of the input signal arrives before the set counter period, and frequency detect output is LOW when a consecutive edge arrives later than the set counter period.

Figure 11 displays the frequency detector output. As seen in Figure 11, the frequency detect output is LOW when the input signal frequency is 50Hz, and the output is HIGH when the input signal frequency is 60Hz.

GreenPAK based AC-Power Phase Cut Control with System Monitoring Features

5.4 Modifying the Phase Delay

For a specific power consumption, different phase delays are written in CNT0/DLY0 macrocell via I2C. To re-write different phase delays the following steps are recommended.

1. Assert Software_Enable (I2C Virtual Input 0 - OUT0) LOW
2. Write a new phase delay time on CNT0/DLY0 registers
3. Assert Software_Enable HIGH

Following these steps in sequence guarantees proper synchronization of the new data written in CNT0/DLY0 registers. [Table 1](#) describes the I2C address of the CNT0/DLY0 macrocell.

Table 1: CNT0/DLY0 I2C Address

I2C Address	CNT0/DLY0 Data Bits
0x95	D[15:0]
0x96	

6 TRIAC Driver Circuit

The TRIAC driver circuit consists of an opto-isolator with photo-TRIAC and TRIAC for driving the load.

[Figure 12](#) shows the opto-isolator with photo-TRIAC. As indicated in [Figure 12](#), the opto-isolator is comprised of a LED and a photo-sensitive device, photo-TRIAC. This isolator isolates DC and AC signals. The phase delays generated by the [GreenPAK](#) device are connected to the input LED of the opto-isolator. These signals travel by LED emission and fall onto the gate of the photo-TRIAC.

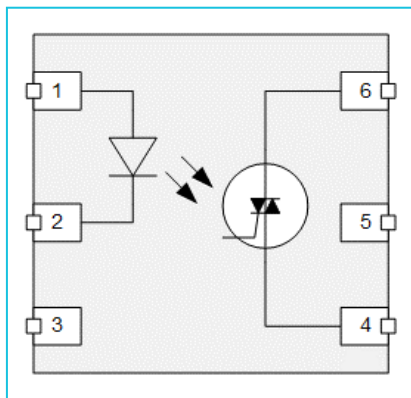

Figure 12: Photo-TRIAC Opto-isolator

The outputs of the photo-TRIAC are connected to the power TRIAC, which is then connected to the load. A positive pulse at the gate of TRIAC triggers it into the ON state. The property of a TRIAC is that it automatically turns OFF at each half cycle of the sinusoidal supply voltage as the instantaneous voltage and load current falls to zero. The TRIAC starts latching the data once again at the next half cycle. The TRIAC can be turned OFF by either reducing the current across its terminals below its minimum holding current, or when the supply voltage is cut-off. The signal at the power TRIAC is the desired phase cut output of the input AC signal.

GreenPAK based AC-Power Phase Cut Control with System Monitoring Features

7 Testing

Figure 13 demonstrates the schematic of the phase cut logic using GreenPAK. The main components of the test setup are a half-wave rectifier, an opto-isolator with phototransistor, a GreenPAK, an opto-isolator with photo-TRIAC, and a TRIAC. The test schematic shows the opto-isolators used for testing. The base of phototransistor is connected to GND to achieve a stable output and reduce false triggering due to electrical noise.

As indicated in Figure 13, the input AC signal is applied across LIVE and Neutral terminals. The output load is connected across Load_LIVE and Load_Neutral terminals. There are two external buttons, each connected to Push Button #1 (Pin 5) and Push Button #2 (Pin 6) on GreenPAK. The voltage across the resistor divider is connected to Input Voltage (Pin 9) on GreenPAK. An I2C compatible MCU is also present for the software control of the design. MCU's SCL and SDA lines are respectively connected to the GreenPAK's SCL and SDA lines through pull-up resistors.

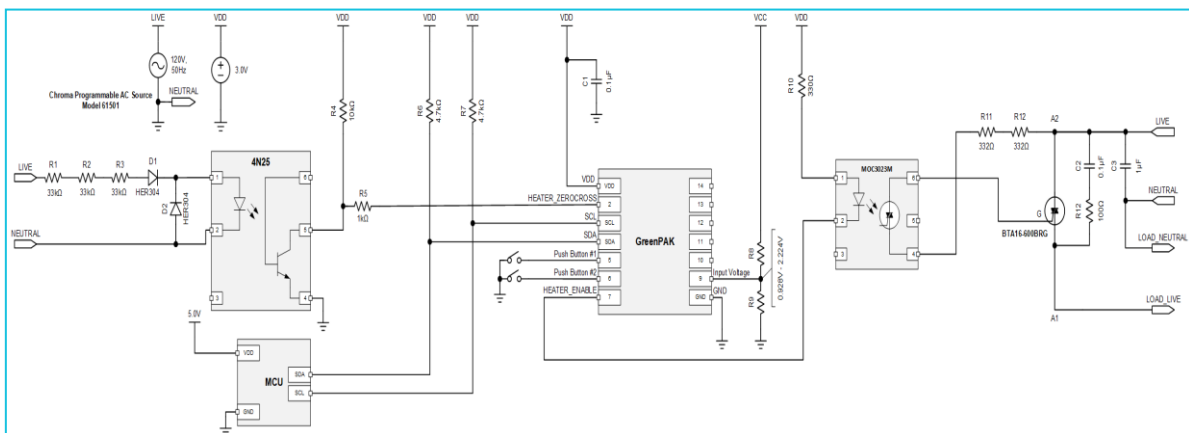

Figure 13: Phase Cut Test Schematic

Figure 14 displays the software control phase cut outputs of the test schematic with the assumption that all the system monitoring features are in range. Data on CNT0/DLY0 macrocell is written through I2C by following the steps in 5.4. The phase delayed outputs are displayed on Heater_Enable (Pin 7) according to the set phase delay on CNT0/DLY0, and appropriate phase cut outputs are also shown in Figure 14. The phase cut outputs are present on the load only when Software Enable is HIGH. Once software enable goes LOW, the phase cut output also goes LOW.

Figure 15 shows the hardware control phase cut outputs with the assumption that all system monitoring features are in range. At each alternate button press, a pre-programmed phase delay is routed to Heater_Enable (Pin 7) and appropriately displayed on the phase cut output. Once the button is released, Heater_Enable (Pin 7) goes LOW and also the phase cut output.

8 Feature Extension

The GreenPAK can be configured with any MCU capable of communicating through I2C. DA14531 Smartbond Tiny Development Kit-USB consists of IOs that can be configured as open drain outputs for I2C communication.

- Channel 1 (magenta/top line) - (AC Input)
- Channel 2 (yellow/2nd line) - PIN#2 (Heater_Zero)
- Channel 3 (black/3rd line) - I2C Virtual Input 0 - OUT0 (Software Enable)
- Channel 4 (blue/4th line) - PIN#7 (Heater_Enable)
- Channel 5 (green/bottom line) - Cycle Skip Output

GreenPAK based AC-Power Phase Cut Control with System Monitoring Features

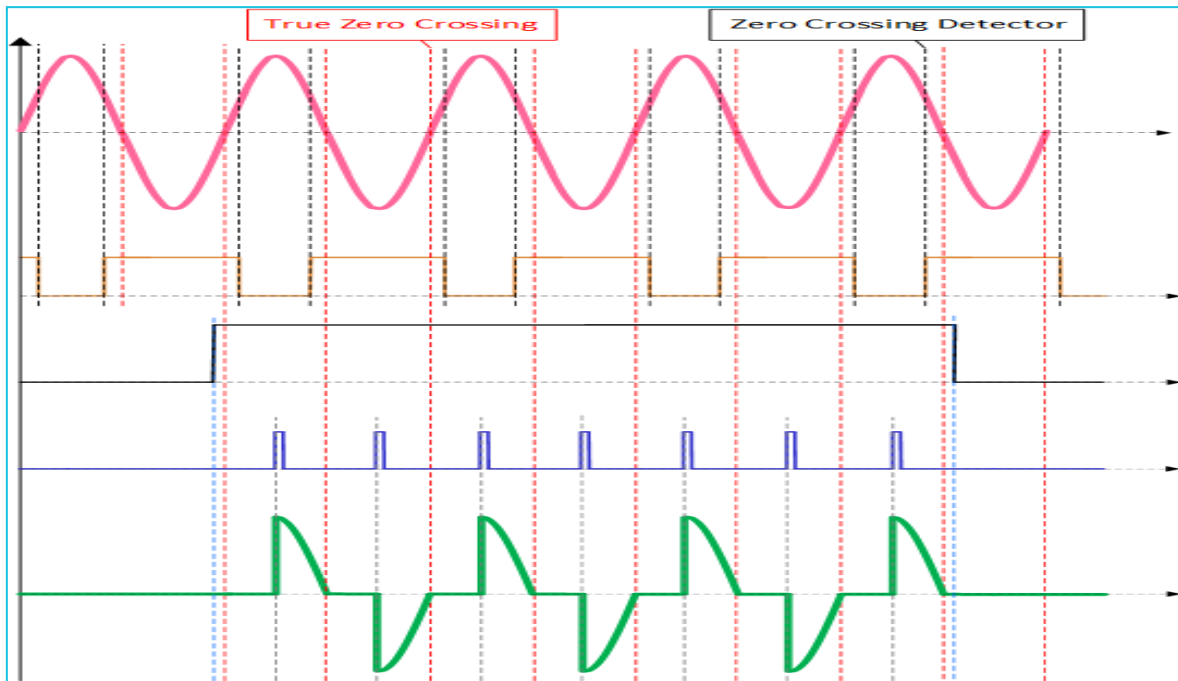

Figure 14: Software Control Phase Cut Output

- Channel 1 (magenta/top line) - (AC Input)
- Channel 2 (yellow/2nd line) - PIN#2 (Heater_Zero)
- Channel 3 (black/3rd line) - PIN#5 (Push Button #1)
- Channel 4 (blue/4th line) - PIN#7 (Heater_Enable)
- Channel 5 (green/bottom line) - Cycle Skip Output

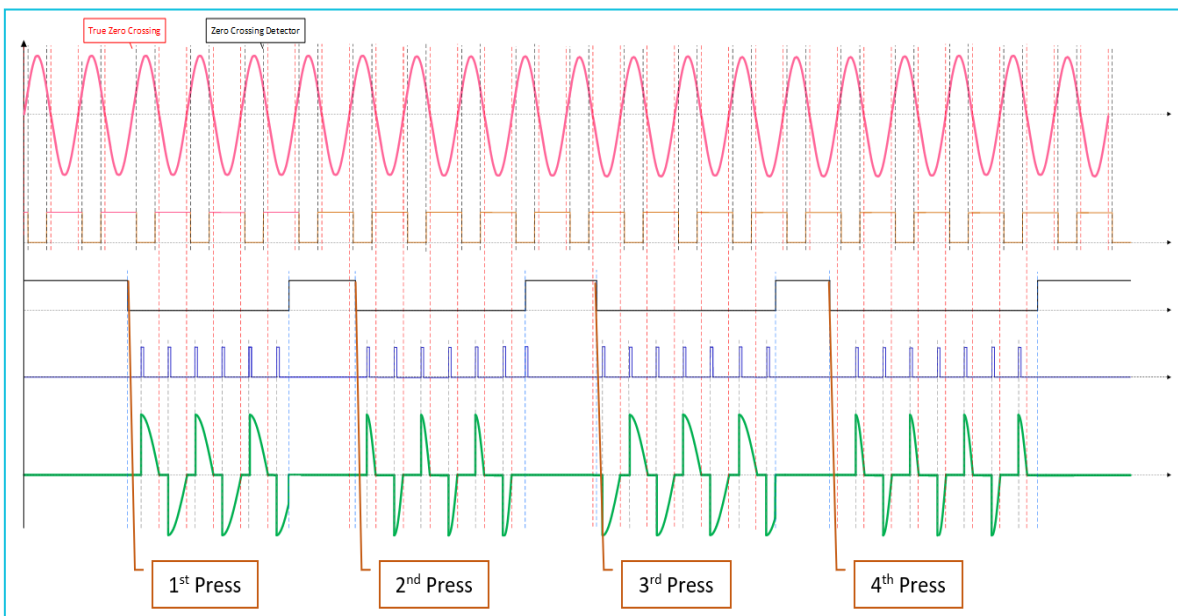

Figure 15: Hardware Control Phase Cut Output

Figure 16 displays the test setup of phase cut logic using DA14531 USB Development Kit. The power to DA14531 USB Development Kit is provided through a USB port in the kit. As exhibited in Figure 16, P0_2 (Port 0 - Pin 2) and P0_8 (Port 0 - Pin 8) pins are respectively configured as SCL and SDA for I2C communication. Please follow the steps in 5.4 to send I2C commands to GreenPAK's CNT0/DLY0 macrocell for modifying the phase delays. Similar results on the phase cut outputs are obtained when I2C commands are supplied from the DA14531 USB Development Kit.

GreenPAK based AC-Power Phase Cut Control with System Monitoring Features

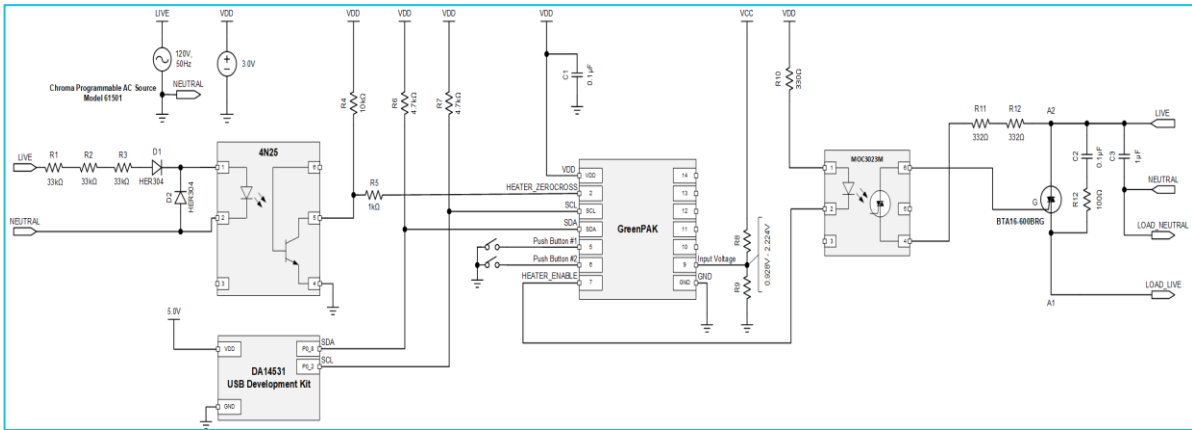

Figure 16: DA14531 USB Development Kit based Test Schematic

9 Demonstration PCB

Figure 17 shows the demonstration board for both phase cut and cycle skip logic. This PCB can be readily used worldwide as the GreenPAK design supports both 50Hz and 60Hz AC frequencies. AC mains supply is applied to the board through the AC mains connector. For demonstration, a light bulb is used as a load.

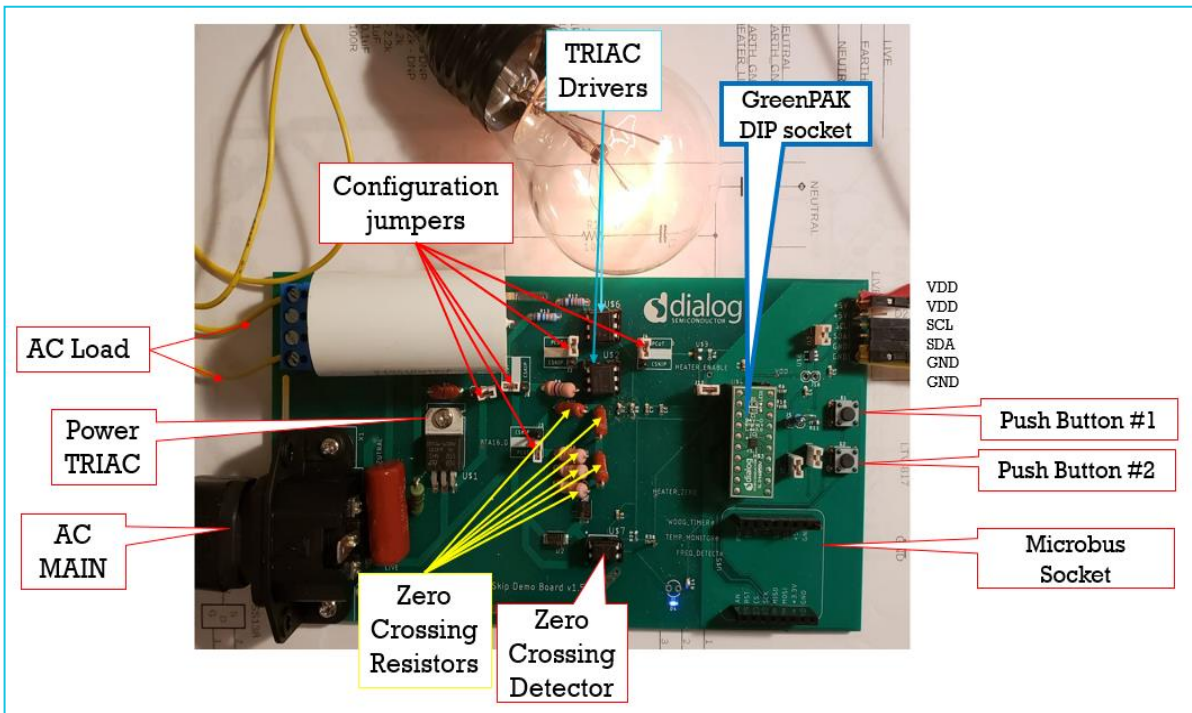

Figure 17: Phase Cut and Cycle Skip PCB

The user needs to only connect the AC mains supply and load.

As evidenced from Figure 17, 2 separate TRIAC drivers and configuration jumpers are present on the board to switch from phase cut to cycle skip logic. The design is programmed on the GreenPAK DIP socket and 2 push buttons, each for hardware control of the designs and emergency shutdown respectively are present on the PCB.

Test points for both connecting a 5V DC supply, and communicating to the GreenPAK DIP socket through an I2C (SCL and SDA) compatible MCU are present on top right corner of the PCB.

GreenPAK based AC-Power Phase Cut Control with System Monitoring Features

This board also supports a DA14531 based Microbus socket to control GreenPAK through I2C communication.

10 Conclusion

The GreenPAK design described in this application note is easy to use, minimizes cost, saves board space and component count.

Generally, MCUs have limited IOs. So, offloading the control to small and inexpensive GreenPAK ICs saves IOs for other critical operations.

Moreover, these GreenPAK ICs are flexible and easy to test. The design can be modified to include additional system monitoring features and increase/decrease the number of programmed phase delays (hardware control only). Once the design is modified, a new design file can be programmed on-chip with the click of a few buttons and re-soldered on board. This flexibility saves time and can accommodate last minute design changes. It also offers design security by locking the design file to limit the visibility. By using this design, the user controls phase delays through both I2C and an external push button.

**GreenPAK based AC-Power Phase Cut Control with
System Monitoring Features****Revision History**

Revision	Date	Description
1.0	31-Mar-2021	Initial version.

IMPORTANT NOTICE AND DISCLAIMER

RENESAS ELECTRONICS CORPORATION AND ITS SUBSIDIARIES (“RENESAS”) PROVIDES TECHNICAL SPECIFICATIONS AND RELIABILITY DATA (INCLUDING DATASHEETS), DESIGN RESOURCES (INCLUDING REFERENCE DESIGNS), APPLICATION OR OTHER DESIGN ADVICE, WEB TOOLS, SAFETY INFORMATION, AND OTHER RESOURCES “AS IS” AND WITH ALL FAULTS, AND DISCLAIMS ALL WARRANTIES, EXPRESS OR IMPLIED, INCLUDING, WITHOUT LIMITATION, ANY IMPLIED WARRANTIES OF MERCHANTABILITY, FITNESS FOR A PARTICULAR PURPOSE, OR NON-INFRINGEMENT OF THIRD-PARTY INTELLECTUAL PROPERTY RIGHTS.

These resources are intended for developers who are designing with Renesas products. You are solely responsible for (1) selecting the appropriate products for your application, (2) designing, validating, and testing your application, and (3) ensuring your application meets applicable standards, and any other safety, security, or other requirements. These resources are subject to change without notice. Renesas grants you permission to use these resources only to develop an application that uses Renesas products. Other reproduction or use of these resources is strictly prohibited. No license is granted to any other Renesas intellectual property or to any third-party intellectual property. Renesas disclaims responsibility for, and you will fully indemnify Renesas and its representatives against, any claims, damages, costs, losses, or liabilities arising from your use of these resources. Renesas' products are provided only subject to Renesas' Terms and Conditions of Sale or other applicable terms agreed to in writing. No use of any Renesas resources expands or otherwise alters any applicable warranties or warranty disclaimers for these products.

(Disclaimer Rev.1.01)

Corporate Headquarters

TOYOSU FORESIA, 3-2-24 Toyosu,
Koto-ku, Tokyo 135-0061, Japan
www.renesas.com

Trademarks

Renesas and the Renesas logo are trademarks of Renesas Electronics Corporation. All trademarks and registered trademarks are the property of their respective owners.

Contact Information

For further information on a product, technology, the most up-to-date version of a document, or your nearest sales office, please visit www.renesas.com/contact-us/.