

### FEATURES:

- 2.5V<sub>DD</sub>
- 6 pairs of programmable skew outputs
- Low skew: 100ps all outputs at same interface level, 250ps all outputs at different interface levels
- Selectable positive or negative edge synchronization
- Tolerant of spread spectrum input clock
- Synchronous output enable
- Selectable inputs
- Input frequency: 4.17MHz to 250MHz
- Output frequency: 12.5MHz to 250MHz
- Internal non-volatile EEPROM
- JTAG or I<sup>2</sup>C bus serial interface for programming
- Hot insertable and over-voltage tolerant inputs
- Feedback divide selection with multiply ratios of (1-6, 8, 10, 12)
- Selectable HSTL, eHSTL, 1.8V/2.5V LVTTTL, or LVEPECL input interface
- Selectable HSTL, eHSTL, or 1.8V/2.5V LVTTTL output interface for each output bank
- Selectable differential or single-ended inputs and six differential outputs
- PLL bypass for DC testing
- External differential feedback, internal loop filter
- Low Jitter: <75ps cycle-to-cycle, all outputs at same interface level: <100ps cycle-to-cycle all outputs at different interface levels
- Power-down mode
- Lock indicator
- Available in VFQFPN package

### DESCRIPTION:

The IDT5T9891 is a 2.5V PLL differential clock driver intended for high performance computing and data-communications applications. A key feature of the programmable skew is the ability of outputs to lead or lag the REF input signal. The IDT5T9891 has six differential programmable skew outputs in six banks, including a dedicated differential feedback through the use of JTAG or I<sup>2</sup>C programming. The redundant input capability allows for a smooth change over to a secondary clock source when the primary clock source is absent.

The clock driver can be configured through the use of JTAG/I<sup>2</sup>C programming. An internal EEPROM will allow the user to save and restore the configuration of the device.

The feedback bank allows divide-by-functionality from 1 to 12 through the use of JTAG or I<sup>2</sup>C programming. This provides the user with frequency multiplication 1 to 12 without using divided outputs for feedback. Each output bank also allows for a divide-by functionality of 2 or 4.

The IDT5T9891 features a user-selectable, single-ended or differential input to six differential outputs. The differential clock driver also acts as a translator from a differential HSTL, eHSTL, 1.8V/2.5V LVTTTL, LVEPECL, or single-ended 1.8V/2.5V LVTTTL input to HSTL, eHSTL, or 1.8V/2.5V LVTTTL outputs. Each output bank can be individually configured to be either HSTL, eHSTL, 2.5V LVTTTL, or 1.8V LVTTTL, including the feedback bank. Also, each clock input can be individually configured to accept 2.5V LVTTTL, 1.8V LVTTTL, or differential signals. The outputs can be synchronously enabled/disabled. The differential outputs can be synchronously enabled/disabled.

Furthermore, all the outputs can be synchronized with the positive edge of the REF clock input or the negative edge of REF.

FUNCTIONAL BLOCK DIAGRAM

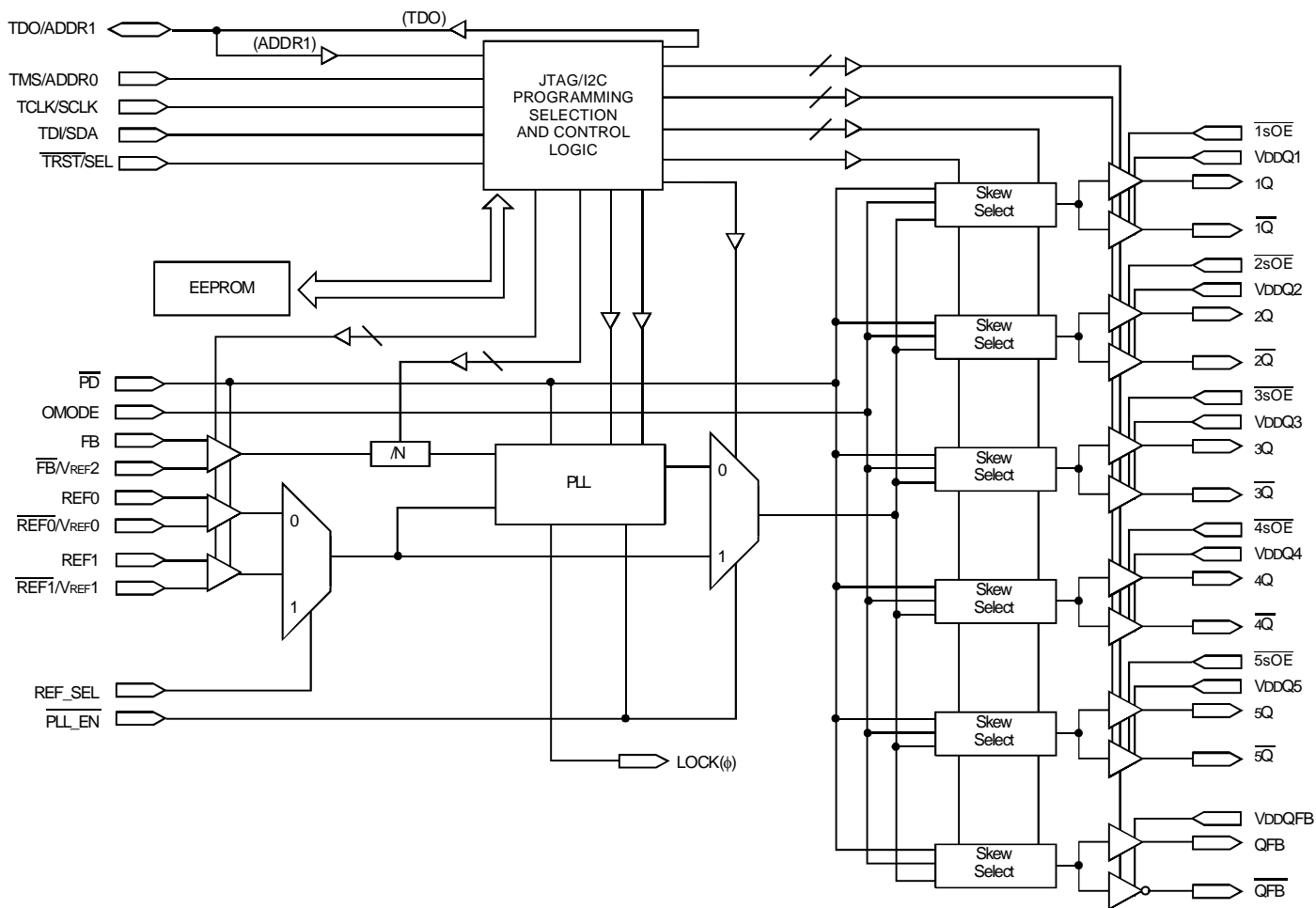

PIN CONFIGURATION

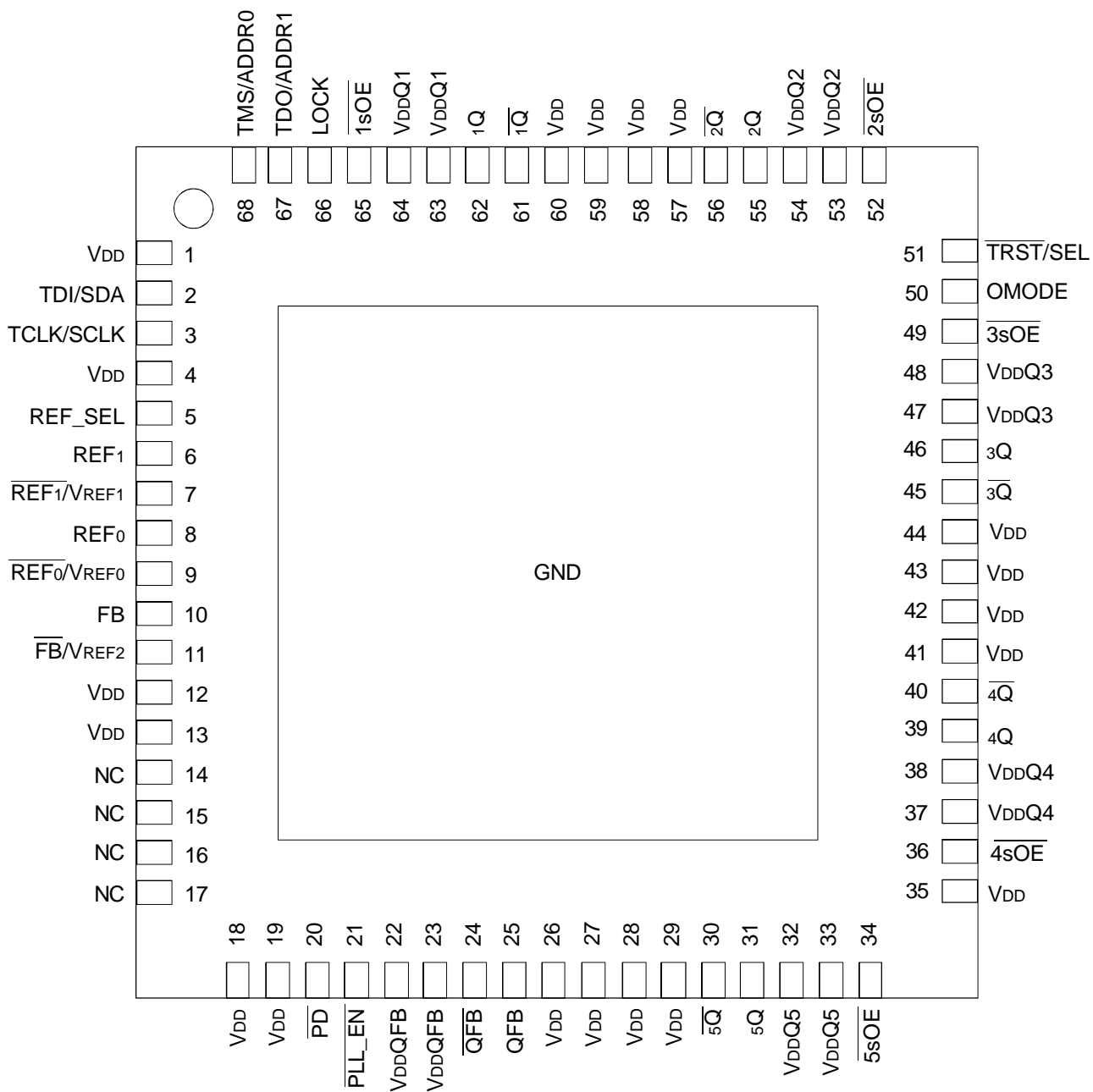

VFQFPN  
TOP VIEW

## ABSOLUTE MAXIMUM RATINGS<sup>(1)</sup>

Symbol	Description	Max	Unit
V <sub>DDON</sub> , V <sub>DD</sub>	Power Supply Voltage <sup>(2)</sup>	-0.5 to +3.6	V
V <sub>I</sub>	Input Voltage	-0.5 to +3.6	V
V <sub>O</sub>	Output Voltage	-0.5 to V <sub>DDQ</sub> + 0.5	V
V <sub>REF</sub>	Reference Voltage <sup>(3)</sup>	-0.5 to +3.6	V
T <sub>J</sub>	Junction Temperature	150	°C
T <sub>STG</sub>	Storage Temperature	-65 to +165	°C

### NOTES:

- Stresses greater than those listed under ABSOLUTE MAXIMUM RATINGS may cause permanent damage to the device. This is a stress rating only and functional operation of the device at these or any other conditions above those indicated in the operational sections of this specification is not implied. Exposure to absolute maximum rating conditions for extended periods may affect reliability.
- V<sub>DDON</sub> and V<sub>DD</sub> internally operate independently. No power sequencing requirements need to be met.
- Not to exceed 3.6V.

## CAPACITANCE (T<sub>A</sub> = +25°C, f = 1MHz, V<sub>IN</sub> = 0V)

Parameter	Description	Min.	Typ.	Max.	Unit
C <sub>IN</sub>	Input Capacitance	2.5	3	3.5	pF
C <sub>OUT</sub>	Output Capacitance	—	6.3	7	pF

### NOTE:

- Capacitance applies to all inputs except JTAG/I<sup>2</sup>C signals, SEL, ADDR0, and ADDR1.

## RECOMMENDED OPERATING RANGE

Symbol	Description	Min.	Typ.	Max.	Unit
T <sub>A</sub>	Ambient Operating Temperature	-40	+25	+85	°C
V <sub>DD</sub> <sup>(1)</sup>	Internal Power Supply Voltage	2.3	2.5	2.7	V
V <sub>DDON</sub> <sup>(1)</sup>	HSTL Output Power Supply Voltage	1.4	1.5	1.6	V
	Extended HSTL and 1.8V LVTTTL Output Power Supply Voltage	1.65	1.8	1.95	V
	2.5V LVTTTL Output Power Supply Voltage		V <sub>DD</sub>		V
V <sub>T</sub>	Termination Voltage		V <sub>DDON</sub> / 2		V

### NOTE:

- All power supplies should operate in tandem. If V<sub>DD</sub> or V<sub>DDON</sub> is at maximum, then V<sub>DDON</sub> or V<sub>DD</sub> (respectively) should be at maximum, and vice-versa.

## PIN DESCRIPTION

Symbol	I/O	Type	Description
REF[1:0]	I	Adjustable <sup>(1)</sup>	Clock input. REF[1:0] is the "true" side of the differential clock input. If operating in single-ended mode, REF[1:0] is the clock input.
$\overline{\text{REF}}[1:0]$ / V <sub>REF</sub> [1:0]	I	Adjustable <sup>(1)</sup>	Complementary clock input. $\overline{\text{REF}}[1:0]$ /V <sub>REF</sub> [1:0] is the "complementary" side of REF[1:0] if the input is in differential mode. If operating in single-ended mode, $\overline{\text{REF}}[1:0]$ /V <sub>REF</sub> [1:0] is left floating. For single-ended operation in differential mode, $\overline{\text{REF}}[1:0]$ /V <sub>REF</sub> [1:0] should be set to the desired toggle voltage for REF[1:0]: 2.5V LVTTTL                      V <sub>REF</sub> = 1250mV (SSTL2 compatible) 1.8V LVTTTL, eHSTL           V <sub>REF</sub> = 900mV HSTL                                      V <sub>REF</sub> = 750mV LVEPECL                              V <sub>REF</sub> = 1082mV
FB	I	Adjustable <sup>(1)</sup>	Clock input. FB is the "true" side of the differential feedback clock input. If operating in single-ended mode, FB is the feedback clock input.
$\overline{\text{FB}}$ /V <sub>REF2</sub>	I	Adjustable <sup>(1)</sup>	Complementary feedback clock input. $\overline{\text{FB}}$ /V <sub>REF2</sub> is the "complementary" side of FB if the input is in differential mode. If operating in single-ended mode, $\overline{\text{FB}}$ /V <sub>REF2</sub> is left floating. For single-ended operation in differential mode, $\overline{\text{FB}}$ /V <sub>REF2</sub> should be set to the desired toggle voltage for FB: 2.5V LVTTTL                      V <sub>REF</sub> = 1250mV (SSTL2 compatible) 1.8V LVTTTL, eHSTL           V <sub>REF</sub> = 900mV HSTL                                      V <sub>REF</sub> = 750mV LVEPECL                              V <sub>REF</sub> = 1082mV

### NOTE:

- Inputs are capable of translating the following interface standards. User can select between:

Single-ended 2.5V LVTTTL levels  
 Single-ended 1.8V LVTTTL levels  
 or  
 Differential 2.5V/1.8V LVTTTL levels  
 Differential HSTL and eHSTL levels  
 Differential LVEPECL levels

## PIN DESCRIPTION, CONTINUED

Symbol	I/O	Type	Description
REF_SEL	I	LVTTL <sup>(1)</sup>	Reference clock select. When LOW, selects REF <sub>0</sub> and $\overline{\text{REF}}_0/\text{VREF}_0$ . When HIGH, selects REF <sub>1</sub> and $\overline{\text{REF}}_1/\text{VREF}_1$ .
$\overline{\text{nsOE}}$	I	LVTTL <sup>(1)</sup>	Synchronous output enable/disable. Each outputs's enable/disable state can be controlled either with the $\overline{\text{nsOE}}$ pin or through JTAG or I <sup>2</sup> C programming, corresponding bits 52 - 56. When the $\overline{\text{nsOE}}$ is HIGH or the corresponding Bit (52 - 56) is 1, the output will be synchronously disabled. When the $\overline{\text{nsOE}}$ is LOW and the corresponding Bit (52 - 56) is 0, the output will be enabled. (See JTAG/I <sup>2</sup> C Serial Configuration table.)
QFB	O	Adjustable <sup>(2)</sup>	Feedback clock output
$\overline{\text{QFB}}$	O	Adjustable <sup>(2)</sup>	Complementary feedback clock output
nQ	O	Adjustable <sup>(2)</sup>	Clock outputs
$\overline{\text{nQ}}$	O	Adjustable <sup>(2)</sup>	Complementary clock outputs
$\overline{\text{PLL\_EN}}$	I	LVTTL <sup>(1)</sup>	PLL enable/disable control. The PLL's enable/disable state can be controlled either with the $\overline{\text{PLL\_EN}}$ pin or through JTAG or I <sup>2</sup> C programming, corresponding Bit 57. When $\overline{\text{PLL\_EN}}$ is HIGH or the corresponding Bit 57 is 1, the PLL is disabled and REF <sub>[1:0]</sub> goes to all outputs. When $\overline{\text{PLL\_EN}}$ is LOW and the corresponding Bit 57 is 0, the PLL will be active.
$\overline{\text{PD}}$	I	LVTTL <sup>(1)</sup>	Power down control. When $\overline{\text{PD}}$ is LOW, the inputs are disabled and internal switching is stopped. The OMODE pin in conjunction with the corresponding Bit 59 selects whether the outputs are gated LOW/HIGH or tri-stated. When OMODE is HIGH or Bit 59 is 1, Bit 58 determines the level at which the outputs stop. When Bit 58 is 0/1, the nQ and QFB are stopped in a HIGH/LOW state, while the $\overline{\text{nQ}}$ and $\overline{\text{QFB}}$ are stopped in a LOW/HIGH state. When OMODE is LOW and Bit 59 is 0, the outputs are tri-stated. Set $\overline{\text{PD}}$ HIGH for normal operation. (See JTAG/I <sup>2</sup> C Serial Configuration table.)
LOCK	O	LVTTL	PLL lock indication signal. HIGH indicates lock. LOW indicates that the PLL is not locked and outputs may not be synchronized to the inputs. The output will be 2.5V LVTTL. (For more information on application specific use of the LOCK pin, please see AN237.)
OMODE	I	LVTTL <sup>(1)</sup>	Output disable control. Used in conjunction with $\overline{\text{nsOE}}$ and $\overline{\text{PD}}$ . The outputs' disable state can be controlled either with the OMODE pin or through JTAG or I <sup>2</sup> C programming, corresponding Bit 59. When OMODE is HIGH or the corresponding Bit 59 is 1, the outputs' disable state will be gated and Bit 58 will determine the level at which the outputs stop. When Bit 58 is 0/1, the nQ and QFB are stopped in a HIGH/LOW state, while the $\overline{\text{nQ}}$ and $\overline{\text{QFB}}$ are stopped in a LOW/HIGH state. When OMODE is LOW and its corresponding bit 59 is 0, the outputs disable state will be the tri-state. (See JTAG/I <sup>2</sup> C Serial Configurations tables.)
$\overline{\text{TRST}}/\text{SEL}$	I/I	LVTTL/ LVTTL <sup>(4,5)</sup> 3-Level <sup>(3,4,5)</sup>	$\overline{\text{TRST}}$ - Active LOW input to asynchronously reset the JTAG boundary-scan circuit. SEL - Select programming interface control for the dual-function pins. When HIGH, the dual-function pins are set for JTAG programming. When LOW, the dual-function pins are set for I <sup>2</sup> C programming and the JTAG interface is asynchronously placed in the Test Logic Reset state.
TDO/ADDR1	O/I	LVTTL/ 3-Level <sup>(3,4,5)</sup>	TDO - Serial data output pin for instructions as well as test and programming data. Data is shifted in on the falling edge of TCLK. The pin is tri-stated if data is not being shifted out of the device. ADDR1 - Used to define a unique I <sup>2</sup> C address for this device. Only for I <sup>2</sup> C programming. (See JTAG/I <sup>2</sup> C Serial Interface Description.)
TMS/ADDR0	I/I	LVTTL/ LVTTL <sup>(4,5)</sup>	TMS - Input pin that provides the control signal to determine the transitions of the JTAG TAP controller state machine. Transitions within the state machine occur at the rising edge of TCLK. Therefore, TMS must be set up before the rising edge of TCLK. TMS is evaluated on the rising edge of TCLK. ADDR0 - Used to define a unique I <sup>2</sup> C address for this device. Only for I <sup>2</sup> C programming. (See JTAG/I <sup>2</sup> C Serial Interface Description.)
TCLK/SCLK	I/I	LVTTL/ LVTTL <sup>(4,5)</sup>	TCLK - The clock input to the JTAG BST circuitry. SCLK - Serial clock for I <sup>2</sup> C programming
TDI/SDA	I/I	LVTTL/	TDI - Serial input pin for instructions as well as test and programming data. Data is shifted in on the rising edge of TCLK. SDA - Serial data (see JTAG/I <sup>2</sup> C Serial Description table)
VDDON		PWR	Power supply for each pair of outputs. When using 2.5V LVTTL, 1.8V LVTTL, HSTL, or eHSTL outputs, VDDON should be set to its corresponding outputs (see Front Block Diagram). When using 2.5V LVTTL outputs, VDDON should be connected to VDD.
VDD		PWR	Power supply for phase locked loop, lock output, inputs, and other internal circuitry
GND		PWR	Ground

## NOTES:

1. Pins listed as LVTTL inputs can be configured to accept 1.8V or 2.5V signals through the use of the I<sup>2</sup>C/JTAG programming, bit 61. (See JTAG/I<sup>2</sup>C Serial Description.)
2. Outputs are user selectable to drive 2.5V, 1.8V LVTTL, eHSTL, or HSTL interface levels when used with the appropriate VDDON voltage.
3. 3-level inputs are static inputs and must be tied to VDD or GND or left floating. These inputs are not hot-insertable or over voltage tolerant.
4. The JTAG (TDO, TMS, TCLK, and TDI) and I<sup>2</sup>C (ADDR1, ADDR0, SCLK, and SDA) signals share the same pins (dual-function pins) for which the  $\overline{\text{TRST}}/\text{SEL}$  pin will select between the two programming interfaces.
5. JTAG and I<sup>2</sup>C pins accept 2.5V signals. The JTAG input pins (TMS, TCLK, TDI,  $\overline{\text{TRST}}$ ) will also accept 1.8V signals.

## JTAG/ I<sup>2</sup>C SERIAL DESCRIPTION

Bit	Description
95:62	Reserved Bits. Set bits 95:62 to '0'.
61	Input interface selection for control pins (REF_SEL, PD, PLL_EN, OMODE, nSOE). When bit 61 is '1', the control pins are 2.5V LVTTTL. When bit 61 is '0', the control pins are 1.8V LVTTTL.
60	VCO frequency range. When '0', range is 50MHz-125MHz. When '1', range is 100MHz-250MHz.
59	Output's disable state. See corresponding external pin OMODE for Pin Description table.
58	Positive/Negative edge control. When '0'/'1', the outputs are synchronized with the negative/positive edge of the reference clock.
57	PLL enable/disable. See corresponding external pin PLL_EN in Pin Description table. <sup>(1)</sup>
56	Output disable/enable for 1Q[1:0] outputs. See corresponding external pin 1SOE in Pin Description table.
55	Output disable/enable for 2Q[1:0] outputs. See corresponding external pin 2SOE in Pin Description table.
54	Output disable/enable for 3Q[1:0] outputs. See corresponding external pin 3SOE in Pin Description table.
53	Output disable/enable for 4Q[1:0] outputs. See corresponding external pin 4SOE in Pin Description table.
52	Output disable/enable for 5Q[1:0] outputs. See corresponding external pin 5SOE in Pin Description table.
51	FB Divide-by-N selection
50	FB Divide-by-N selection
49	FB Divide-by-N selection
48	FB Divide-by-N selection
47	Output drive strength selection for 2.5V LVTTTL, 1.8V LVTTTL, or HSTL/eHSTL on bank 1
46	Output drive strength selection for 2.5V LVTTTL, 1.8V LVTTTL, or HSTL/eHSTL on bank 1
45	Output drive strength selection for 2.5V LVTTTL, 1.8V LVTTTL, or HSTL/eHSTL on bank 2
44	Output drive strength selection for 2.5V LVTTTL, 1.8V LVTTTL, or HSTL/eHSTL on bank 2
43	Output drive strength selection for 2.5V LVTTTL, 1.8V LVTTTL, or HSTL/eHSTL on bank 3
42	Output drive strength selection for 2.5V LVTTTL, 1.8V LVTTTL, or HSTL/eHSTL on bank 3
41	Output drive strength selection for 2.5V LVTTTL, 1.8V LVTTTL, or HSTL/eHSTL on bank 4
40	Output drive strength selection for 2.5V LVTTTL, 1.8V LVTTTL, or HSTL/eHSTL on bank 4
39	Output drive strength selection for 2.5V LVTTTL, 1.8V LVTTTL, or HSTL/eHSTL on bank 5
38	Output drive strength selection for 2.5V LVTTTL, 1.8V LVTTTL, or HSTL/eHSTL on bank 5
37	FB output drive strength selection for 2.5V LVTTTL, 1.8V LVTTTL, or HSTL/eHSTL on FB bank
36	FB output drive strength selection for 2.5V LVTTTL, 1.8V LVTTTL, or HSTL/eHSTL on FB bank
35	REF0 Input interface selection for 2.5V LVTTTL, 1.8V LVTTTL, or Differential
34	REF0 Input interface selection for 2.5V LVTTTL, 1.8V LVTTTL, or Differential
33	REF1 input interface selection for 2.5V LVTTTL, 1.8V LVTTTL, or Differential
32	REF1 input interface selection for 2.5V LVTTTL, 1.8V LVTTTL, or Differential
31	FB input interface selection for 2.5V LVTTTL, 1.8V LVTTTL, or Differential
30	FB input interface selection for 2.5V LVTTTL, 1.8V LVTTTL, or Differential
29	Skew or frequency selection for bank 1
28	Skew or frequency selection for bank 1
27	Skew or frequency selection for bank 1
26	Skew or frequency selection for bank 1
25	Skew or frequency selection for bank 1
24	Skew or frequency selection for bank 2
23	Skew or frequency selection for bank 2
22	Skew or frequency selection for bank 2

**NOTE:**  
1. Only for EEPROM operation; bit 57 must be set to 0 to enable the PLL for proper EEPROM operation. The EEPROM access times are based on the VCO frequency of the PLL (refer to the EEPROM Operation section).

JTAG/ I<sup>2</sup>C SERIAL DESCRIPTION, CONT.

Bit	Description
21	Skew or frequency selection for bank 2
20	Skew or frequency selection for bank 2
19	Skew or frequency selection for bank 3
18	Skew or frequency selection for bank 3
17	Skew or frequency selection for bank 3
16	Skew or frequency selection for bank 3
15	Skew or frequency selection for bank 3
14	Skew or frequency selection for bank 4
13	Skew or frequency selection for bank 4
12	Skew or frequency selection for bank 4
11	Skew or frequency selection for bank 4
10	Skew or frequency selection for bank 4
9	Skew or frequency selection for bank 5
8	Skew or frequency selection for bank 5
7	Skew or frequency selection for bank 5
6	Skew or frequency selection for bank 5
5	Skew or frequency selection for bank 5
4	Skew or frequency selection for FB bank
3	Skew or frequency selection for FB bank
2	Skew or frequency selection for FB bank
1	Skew or frequency selection for FB bank
0	Skew or frequency selection for FB bank

JTAG/ I<sup>2</sup>C SERIAL CONFIGURATIONS:  
OUTPUT ENABLE/DISABLE

Bit 59 (OMODE)	Bit 56-52 ( $\overline{\text{nsOE}}$ )	Output
X (X)	0 and (L)	Normal Operation
0 and (L)	1 or (H)	Tri-State
1 or (H)	1 or (H)	Gated <sup>(1)</sup>

## NOTE:

1. OMODE and its corresponding Bit 59 selects whether the outputs are gated LOW/HIGH or tri-stated. When OMODE is HIGH or the corresponding Bit 59 is 1, the outputs' disable state will be gated. Bit 58 determines the level at which the outputs stop. When Bit 58 is 0/ 1, the nQ and QFB are stopped in a HIGH/LOW state, while the  $\overline{\text{nQ}}$  and  $\overline{\text{QFB}}$  are stopped in a LOW/HIGH state. When OMODE is LOW and its corresponding Bit 59 is 0, the outputs' disable state will be the tri-state.

JTAG/ I<sup>2</sup>C SERIAL CONFIGURATIONS:  
CLOCK INPUT INTERFACE SELECTION<sup>(1)</sup>

Bit 31, 33, 35	Bit 30, 32, 34	Interface
0	0	Differential <sup>(2)</sup>
0	1	2.5VLVTTL
1	1	1.8VLVTTL

## NOTES:

1. All other states that are undefined in the table will be reserved.
2. Differential input interface for HSTL/eHSTL, LVEPECL (2.5V), and 2.5V/1.8V LVTTTL.

JTAG/ I<sup>2</sup>C SERIAL CONFIGURATIONS:  
POWERDOWN

$\overline{\text{PD}}$	Bit 59 (OMODE)	Output
H	X (X)	Normal Operation
L	0 and (L)	Tri-State
L	1 or (H)	Gated <sup>(1)</sup>

## NOTE:

1. OMODE and its corresponding Bit 59 selects whether the outputs are gated LOW/HIGH or tri-stated. When OMODE is HIGH or the corresponding Bit 59 is 1, the outputs' disable state will be gated. Bit 58 determines the level at which the outputs stop. When Bit 58 is 0/ 1, the nQ and QFB are stopped in a HIGH/LOW state, while the  $\overline{\text{nQ}}$  and  $\overline{\text{QFB}}$  are stopped in a LOW/HIGH state. When OMODE is LOW and its corresponding Bit 59 is 0, the outputs' disable state will be the tri-state.

JTAG/ I<sup>2</sup>C SERIAL CONFIGURATIONS:  
OUTPUT DRIVE STRENGTH SELECTION<sup>(1)</sup>

Bit 37, 39, 41, 43, 45, 47	Bit 36, 38, 40, 42, 44, 46	Interface
0	0	2.5VLVTTL
0	1	1.8VLVTTL
1	0	HSTL/eHSTL

## NOTE:

1. All other states that are undefined in the table will be reserved.

### JTAG/ I<sup>2</sup>C SERIAL CONFIGURATIONS: SKEW OR FREQUENCY SELECT<sup>(1)</sup>

Bit 4, 9, 14, 19, 24, 29	Bit 3, 8, 13, 18, 23, 28	Bit 2, 7, 12, 17, 22, 27	Bit 1, 6, 11, 16, 21, 26	Bit 0, 5, 10, 15, 20, 25	Output Skew
0	0	0	0	1	+7tu
0	0	0	1	0	+6tu
0	0	0	1	1	+5tu
0	0	1	0	0	+4tu
0	0	1	0	1	+3tu
0	0	1	1	0	+2tu
0	0	1	1	1	+1tu
0	0	0	0	0	Zero Skew
0	1	0	0	1	-1tu
0	1	0	1	0	-2tu
0	1	0	1	1	-3tu
0	1	1	0	0	-4tu
0	1	1	0	1	-5tu
0	1	1	1	0	-6tu
0	1	1	1	1	-7tu
1	0	0	0	0	Inverted
1	0	0	0	1	Divide-by-2
1	0	0	1	0	Divide-by-4

**NOTE:**

1. All other states that are undefined in the table will result in zero skew.

### JTAG/ I<sup>2</sup>C SERIAL CONFIGURATIONS: FB DIVIDE-BY-N<sup>(1)</sup>

Bit 51	Bit 50	Bit 49	Bit 48	Divide-by-N	Permitted Output Divide-by-N connected to FB and $\overline{FB}$ /VREF2 <sup>(2)</sup>
0	0	0	0	1	1, 2, 4
0	0	0	1	2	1, 2
0	0	1	0	3	1
0	0	1	1	4	1, 2
0	1	0	0	5	1, 2
0	1	0	1	6	1, 2
0	1	1	0	8	1
0	1	1	1	10	1
1	0	0	0	12	1

**NOTES:**

1. All other states that are undefined in the table will be reserved.
2. Permissible output division ratios connected to FB and  $\overline{FB}$ /VREF2. The frequencies of the REF[1:0] and  $\overline{REF}$  [1:0]/VREF[1:0] inputs will be Fvco/N when the parts are configured for frequency multiplication by using an undivided output for FB and  $\overline{FB}$ /VREF2 and setting N (N = 1-6, 8, 10, 12).

### JTAG/ I<sup>2</sup>C SERIAL CONFIGURATIONS: VCO FREQUENCY SELECT

Bit 60	Min.	Max.
0	50Mhz	125MHz
1	100MHz	250Mhz



## PROGRAMMABLE SKEW

Output skew with respect to the REF[1:0] and  $\overline{\text{REF}}[1:0]/V_{\text{REF}}[1:0]$  input is adjustable to compensate for PCB trace delays, backplane propagation delays or to accommodate requirements for special timing relationships between clocked components. Skew is selectable as a multiple of a time unit (tu) which ranges from 250ps to 1.25ns (see Programmable Skew Range and Resolution Table). There are 18 skew/divide configurations available for each output pair. These configurations are chosen through JTAG/I<sup>2</sup>C programming.

## PROGRAMMABLE SKEW RANGE AND RESOLUTION TABLE

	Bit 60 = 0	Bit 60 = 1	Comments
Timing Unit Calculation (tu)	1/(16 x FNOM)	1/(16 x FNOM)	
VCO Frequency Range (FNOM) <sup>(1,2)</sup>	50 to 125MHz	100 to 250MHz	
Skew Adjustment Range <sup>(3)</sup>			
Max Adjustment:	±8.75ns	±4.375ns	ns
	±157.5°	±157.5°	Phase Degrees
	±43.75%	±43.75%	% of Cycle Time
Example 1, FNOM = 50MHz	tu = 1.25ns	—	
Example 2, FNOM = 75MHz	tu = 0.833ns	—	
Example 3, FNOM = 100MHz	tu = 0.625ns	tu = 0.625ns	
Example 4, FNOM = 150MHz	—	tu = 0.417ns	
Example 5, FNOM = 200MHz	—	tu = 0.313ns	
Example 6, FNOM = 250MHz	—	tu = 0.25ns	

### NOTES:

- The device may be operated outside recommended frequency ranges without damage, but functional operation is not guaranteed.
- The VCO frequency always appears at nQ and  $\overline{nQ}$  outputs when they are operated in their undivided modes. The frequency appearing at the REF[1:0] and  $\overline{\text{REF}}[1:0]/V_{\text{REF}}[1:0]$  and FB and  $\overline{\text{FB}}/V_{\text{REF}2}$  inputs will be FNOM when the QFB and  $\overline{\text{QFB}}$  are undivided and FB divide-by-1. The frequency of the REF[1:0] and  $\overline{\text{REF}}[1:0]/V_{\text{REF}}[1:0]$  and FB and  $\overline{\text{FB}}/V_{\text{REF}2}$  inputs will be FNOM /2 or FNOM /4 when the part is configured for frequency multiplication by using a divided QFB and  $\overline{\text{QFB}}$  and setting FB divide-by-1. Using the FB divide-by-N configuration inputs allows a different method for frequency multiplication (see JTAG/I<sup>2</sup>C Serial Configurations: FB Divide-by-N).
- Skew adjustment range assumes that a zero skew output is used for feedback. If a skewed QFB and  $\overline{\text{QFB}}$  output is used for feedback, then adjustment range will be greater. For example if a 4tu skewed output is used for feedback, all other outputs will be skewed -4tu in addition to whatever skew value is programmed for those outputs. 'Max adjustment' range applies to all output pairs where ±7tu skew adjustment is possible and at the lowest FNOM value.

## EXTERNAL DIFFERENTIAL FEEDBACK

By providing a dedicated external differential feedback, the IDT5T9891 gives users flexibility with regard to divide selection. The FB and  $\overline{\text{FB}}/V_{\text{REF}2}$  signals are compared with the input REF[1:0] and  $\overline{\text{REF}}[1:0]/V_{\text{REF}}[1:0]$  signals at the phase detector in order to drive the VCO. Phase differences cause the VCO of the PLL to adjust upwards or downwards accordingly.

An internal loop filter moderates the response of the VCO to the phase detector. The loop filter transfer function has been chosen to provide minimal jitter (or frequency variation) while still providing accurate responses to input frequency changes.

## MASTER RESET FUNCTIONALITY

The IDT5T9891 performs a reset of the internal output divide circuitry when all five output banks are disabled by toggling the  $\overline{\text{nSOE}}$  pins HIGH. When one or more banks of outputs are enabled by toggling the  $\overline{\text{nSOE}}$  LOW (if the corresponding  $\overline{\text{nSOE}}$  programming bits are also set LOW), the divide circuitry starts again from a known state. In the case that the FB output is selected for divide-by-2 or divide-by-4, the FB output will stop toggling while all five  $\overline{\text{nSOE}}$  pins and bits are LOW, and loss of lock will occur.

## INPUT/OUTPUT SELECTION<sup>(1)</sup>

Input	Output <sup>(2)</sup>
2.5V LVTTTL SE	2.5V LVTTTL,
1.8V LVTTTL SE	1.8V LVTTTL,
2.5V LVTTTL DSE	HSTL,
1.8V LVTTTL DSE	eHSTL
LVEPECL DSE	
eHSTL DSE	
HSTL DSE	
2.5V LVTTTL DIF	
1.8V LVTTTL DIF	
LVEPECL DIF	
eHSTL DIF	
HSTL DIF	

### NOTES:

- The INPUT/OUTPUT SELECTION Table describes the total possible combinations of input and output interfaces. Single-Ended (SE) inputs in a single-ended mode require the REF[1:0] /VREF[1:0] and  $\overline{\text{FB}}/V_{\text{REF}2}$  pins to be left floating. Differential Single-Ended (DSE) is for single-ended operation in differential mode, requiring VREF[1:0] and VREF2. Differential (DIF) inputs are used only in differential mode.
- For each output bank.

## DC ELECTRICAL CHARACTERISTICS OVER OPERATING RANGE

Symbol	Parameter	Test Conditions	Min.	Max	Unit
V <sub>IHH</sub>	Input HIGH Voltage Level <sup>(1)</sup>	3-Level Inputs Only	V <sub>DD</sub> - 0.4	—	V
V <sub>IMM</sub>	Input MID Voltage Level <sup>(1)</sup>	3-Level Inputs Only	V <sub>DD</sub> /2 - 0.2	V <sub>DD</sub> /2 + 0.2	V
V <sub>ILL</sub>	Input LOW Voltage Level <sup>(1)</sup>	3-Level Inputs Only	—	0.4	V
I <sub>3</sub>	3-Level Input DC Current (ADDR0, ADDR1)	V <sub>IN</sub> = V <sub>DD</sub> HIGH Level	—	200	μA
		V <sub>IN</sub> = V <sub>DD</sub> /2 MID Level	-50	+50	
		V <sub>IN</sub> = GND LOW Level	-200	—	
I <sub>PU</sub>	Input Pull-Up Current	V <sub>DD</sub> = Max., V <sub>IN</sub> = GND	-100	—	μA

**NOTE:**  
1. These inputs are normally wired to V<sub>DD</sub>, GND, or left floating. Internal termination resistors bias unconnected inputs to V<sub>DD</sub>/2. If these inputs are switched dynamically after powerup, the function and timing of the outputs may be glitched, and the PLL may require additional t<sub>LOCK</sub> time before all datasheet limits are achieved.

## DC ELECTRICAL CHARACTERISTICS OVER OPERATING RANGE FOR HSTL<sup>(1)</sup>

Symbol	Parameter	Test Conditions	Min.	Typ. <sup>(7)</sup>	Max	Unit
<b>Input Characteristics</b>						
I <sub>IH</sub>	Input HIGH Current	V <sub>DD</sub> = 2.7V V <sub>I</sub> = V <sub>DDQDN</sub> /GND	—	—	±5	μA
I <sub>IL</sub>	Input LOW Current	V <sub>DD</sub> = 2.7V V <sub>I</sub> = GND/V <sub>DDQDN</sub>	—	—	±5	
V <sub>IK</sub>	Clamp Diode Voltage	V <sub>DD</sub> = 2.3V, I <sub>IN</sub> = -18mA	—	-0.7	-1.2	V
V <sub>IN</sub>	DC Input Voltage		-0.3		+3.6	V
V <sub>DIF</sub>	DC Differential Voltage <sup>(2,8)</sup>		0.2		—	V
V <sub>CM</sub>	DC Common Mode Input Voltage <sup>(3,8)</sup>		680	750	900	mV
V <sub>IH</sub>	DC Input HIGH <sup>(4,5,8)</sup>		V <sub>REF</sub> + 100		—	mV
V <sub>IL</sub>	DC Input LOW <sup>(4,6,8)</sup>		—		V <sub>REF</sub> - 100	mV
V <sub>REF</sub>	Single-Ended Reference Voltage <sup>(4,8)</sup>		—	750	—	mV
<b>Output Characteristics</b>						
V <sub>OH</sub>	Output HIGH Voltage	I <sub>OH</sub> = -8mA	V <sub>DDQDN</sub> - 0.4		—	V
		I <sub>OH</sub> = -100μA	V <sub>DDQDN</sub> - 0.1		—	
V <sub>OL</sub>	Output LOW Voltage	I <sub>OL</sub> = 8mA	—		0.4	V
		I <sub>OL</sub> = 100μA	—		0.1	
V <sub>OX</sub>	nQ/nQ̄ and FB/FB̄ Output Crossing Point		V <sub>DDQDN</sub> /2 - 150	V <sub>DDQDN</sub> /2	V <sub>DDQDN</sub> /2 + 150	mV

**NOTES:**  
1. See RECOMMENDED OPERATING RANGE table.  
2. V<sub>DIF</sub> specifies the minimum input differential voltage (V<sub>TR</sub> - V<sub>CP</sub>) required for switching where V<sub>TR</sub> is the "true" input level and V<sub>CP</sub> is the "complement" input level. Differential mode only. The DC differential voltage must be maintained to guarantee retaining the existing HIGH or LOW input. The AC differential voltage must be achieved to guarantee switching to a new state.  
3. V<sub>CM</sub> specifies the maximum allowable range of (V<sub>TR</sub> + V<sub>CP</sub>) /2. Differential mode only.  
4. For single-ended operation, in differential mode,  $\overline{\text{REF}}[1:0]/\text{VREF}[1:0]$  is tied to the DC voltage V<sub>REF</sub>[1:0].  
5. Voltage required to maintain a logic HIGH, single-ended operation in differential mode.  
6. Voltage required to maintain a logic LOW, single-ended operation in differential mode.  
7. Typical values are at V<sub>DD</sub> = 2.5V, V<sub>DDQDN</sub> = 1.5V, +25°C ambient.  
8. The reference clock input is capable of HSTL, eHSTL, LVEPECL, 1.8V or 2.5V LVTTTL operation independent of the device output. (See Input/Output Selection table.)

POWER SUPPLY CHARACTERISTICS FOR HSTL OUTPUTS<sup>(1)</sup>

Symbol	Parameter	Test Conditions <sup>(2)</sup>	Typ.	Max	Unit
I <sub>DDQ</sub>	Quiescent V <sub>DD</sub> Power Supply Current <sup>(3)</sup>	V <sub>DDQ</sub> = Max., REF = LOW, $\overline{PD}$ = HIGH, $\overline{nSOE}$ = LOW, $\overline{PLL\_EN}$ = HIGH, Outputs enabled, All outputs unloaded	112	150	mA
I <sub>DDOQ</sub>	Quiescent V <sub>DDQ</sub> Power Supply Current <sup>(3)</sup>	V <sub>DDQ</sub> = Max., REF = LOW, $\overline{PD}$ = HIGH, $\overline{nSOE}$ = LOW, $\overline{PLL\_EN}$ = HIGH, Outputs enabled, All outputs unloaded	2	75	μA
I <sub>DDPD</sub>	Power Down Current	V <sub>DD</sub> = Max., $\overline{PD}$ = LOW, $\overline{nSOE}$ = LOW, $\overline{PLL\_EN}$ = HIGH	0.3	3	mA
I <sub>DDD</sub>	Dynamic V <sub>DD</sub> Power Supply Current per Output	V <sub>DD</sub> = Max., V <sub>DDQ</sub> = Max., C <sub>L</sub> = 0pF	22	30	μA/MHz
I <sub>DDOQ</sub>	Dynamic V <sub>DDQ</sub> Power Supply Current per Output	V <sub>DD</sub> = Max., V <sub>DDQ</sub> = Max., C <sub>L</sub> = 0pF	19	30	μA/MHz
I <sub>TOT</sub>	Total Power V <sub>DD</sub> Supply Current <sup>(4,5)</sup>	V <sub>DDQ</sub> = 1.5V, F <sub>VCO</sub> = 100MHz, C <sub>L</sub> = 15pF	280	400	mA
		V <sub>DDQ</sub> = 1.5V, F <sub>VCO</sub> = 250MHz, C <sub>L</sub> = 15pF	320	450	
I <sub>TOTO</sub>	Total Power V <sub>DDQ</sub> Supply Current <sup>(4,5)</sup>	V <sub>DDQ</sub> = 1.5V, F <sub>VCO</sub> = 100MHz, C <sub>L</sub> = 15pF	130	200	mA
		V <sub>DDQ</sub> = 1.5V, F <sub>VCO</sub> = 250MHz, C <sub>L</sub> = 15pF	220	330	

## NOTES:

1. These power consumption characteristics are for all the valid input interfaces and cover the worst case input and output interface combinations.
2. The termination resistors are excluded from these measurements.
3. If the differential input interface is used, the true input is held LOW and the complementary input is held HIGH.
4. Bit 60 = 1.
5. All outputs are at the same interface level.

## DIFFERENTIAL INPUT AC TEST CONDITIONS FOR HSTL

Symbol	Parameter	Value	Units
V <sub>DIF</sub>	Input Signal Swing <sup>(1)</sup>	1	V
V <sub>X</sub>	Differential Input Signal Crossing Point <sup>(2)</sup>	750	mV
V <sub>THI</sub>	Input Timing Measurement Reference Level <sup>(3)</sup>	Crossing Point	V
t <sub>r</sub> , t <sub>f</sub>	Input Signal Edge Rate <sup>(4)</sup>	1	V/ns

### NOTES:

1. The 1V peak-to-peak input pulse level is specified to allow consistent, repeatable results in an automatic test equipment (ATE) environment. This device meets the V<sub>DIF</sub> (AC) specification under actual use conditions.
2. A 750mV crossing point level is specified to allow consistent, repeatable results in an automatic test equipment (ATE) environment. This device meets the V<sub>X</sub> specification under actual use conditions.
3. In all cases, input waveform timing is marked at the differential cross-point of the input signals.
4. The input signal edge rate of 1V/ns or greater is to be maintained in the 20% to 80% range of the input waveform.

## DC ELECTRICAL CHARACTERISTICS OVER OPERATING RANGE FOR eHSTL<sup>(1)</sup>

Symbol	Parameter	Test Conditions	Min.	Typ. <sup>(7)</sup>	Max	Unit
<b>Input Characteristics</b>						
I <sub>IH</sub>	Input HIGH Current	V <sub>DD</sub> = 2.7V V <sub>I</sub> = V <sub>DDON</sub> /GND	—	—	±5	μA
I <sub>IL</sub>	Input LOW Current	V <sub>DD</sub> = 2.7V V <sub>I</sub> = GND/V <sub>DDON</sub>	—	—	±5	
V <sub>IK</sub>	Clamp Diode Voltage	V <sub>DD</sub> = 2.3V, I <sub>IN</sub> = -18mA	—	-0.7	-1.2	V
V <sub>IN</sub>	DC Input Voltage		-0.3		+3.6	V
V <sub>DIF</sub>	DC Differential Voltage <sup>(2,8)</sup>		0.2		—	V
V <sub>CM</sub>	DC Common Mode Input Voltage <sup>(3,8)</sup>		800	900	1000	mV
V <sub>IH</sub>	DC Input HIGH <sup>(4,5,8)</sup>		V <sub>REF</sub> + 100		—	mV
V <sub>IL</sub>	DC Input LOW <sup>(4,6,8)</sup>		—		V <sub>REF</sub> - 100	mV
V <sub>REF</sub>	Single-Ended Reference Voltage <sup>(4,8)</sup>		—	900	—	mV
<b>Output Characteristics</b>						
V <sub>OH</sub>	Output HIGH Voltage	I <sub>OH</sub> = -8mA	V <sub>DDON</sub> - 0.4		—	V
		I <sub>OH</sub> = -100μA	V <sub>DDON</sub> - 0.1		—	V
V <sub>OL</sub>	Output LOW Voltage	I <sub>OL</sub> = 8mA	—		0.4	V
		I <sub>OL</sub> = 100μA	—		0.1	V
V <sub>OX</sub>	nQ/nQ and FB/FB Output Crossing Point		V <sub>DDON</sub> /2 - 150	V <sub>DDON</sub> /2	V <sub>DDON</sub> /2 + 150	mV

### NOTES:

1. See RECOMMENDED OPERATING RANGE table.
2. V<sub>DIF</sub> specifies the minimum input differential voltage (V<sub>TR</sub> - V<sub>CP</sub>) required for switching where V<sub>TR</sub> is the "true" input level and V<sub>CP</sub> is the "complement" input level. Differential mode only. The DC differential voltage must be maintained to guarantee retaining the existing HIGH or LOW input. The AC differential voltage must be achieved to guarantee switching to a new state.
3. V<sub>CM</sub> specifies the maximum allowable range of (V<sub>TR</sub> + V<sub>CP</sub>) /2. Differential mode only.
4. For single-ended operation, in a differential mode,  $\overline{\text{REF}}_{[1:0]}/V_{\text{REF}[1:0]}$  is tied to the DC voltage V<sub>REF[1:0]</sub>.
5. Voltage required to maintain a logic HIGH, single-ended operation in differential mode.
6. Voltage required to maintain a logic LOW, single-ended operation in differential mode.
7. Typical values are at V<sub>DD</sub> = 2.5V, V<sub>DDON</sub> = 1.8V, +25°C ambient.
8. The reference clock input is capable of HSTL, eHSTL, LVEPECL, 1.8V or 2.5V LVTTTL operation independent of the device output. (See Input/Output Selection table.)

## POWER SUPPLY CHARACTERISTICS FOR eHSTL OUTPUTS<sup>(1)</sup>

Symbol	Parameter	Test Conditions <sup>(2)</sup>	Typ.	Max	Unit
I <sub>DDQ</sub>	Quiescent V <sub>DD</sub> Power Supply Current <sup>(3)</sup>	V <sub>DDQ</sub> = Max., REF = LOW, $\overline{PD}$ = HIGH, $\overline{nSOE}$ = LOW, $\overline{PLL\_EN}$ = HIGH, Outputs enabled, All outputs unloaded	112	150	mA
I <sub>DDQ</sub>	Quiescent V <sub>DDQ</sub> Power Supply Current <sup>(3)</sup>	V <sub>DDQ</sub> = Max., REF = LOW, $\overline{PD}$ = HIGH, $\overline{nSOE}$ = LOW, $\overline{PLL\_EN}$ = HIGH, Outputs enabled, All outputs unloaded	2	75	μA
I <sub>DDPD</sub>	Power Down Current	V <sub>DD</sub> = Max., $\overline{PD}$ = LOW, $\overline{nSOE}$ = LOW, $\overline{PLL\_EN}$ = HIGH	0.3	3	mA
I <sub>DDD</sub>	Dynamic V <sub>DD</sub> Power Supply Current per Output	V <sub>DD</sub> = Max., V <sub>DDQ</sub> = Max., C <sub>L</sub> = 0pF	22	30	μA/MHz
I <sub>DDQ</sub>	Dynamic V <sub>DDQ</sub> Power Supply Current per Output	V <sub>DD</sub> = Max., V <sub>DDQ</sub> = Max., C <sub>L</sub> = 0pF	22	30	μA/MHz
I <sub>TOT</sub>	Total Power V <sub>DD</sub> Supply Current <sup>(4,5)</sup>	V <sub>DDQ</sub> = 1.8V, F <sub>VCO</sub> = 100MHz, C <sub>L</sub> = 15pF	280	400	mA
		V <sub>DDQ</sub> = 1.8V, F <sub>VCO</sub> = 250MHz, C <sub>L</sub> = 15pF	330	450	
I <sub>TOT</sub>	Total Power V <sub>DDQ</sub> Supply Current <sup>(4,5)</sup>	V <sub>DDQ</sub> = 1.8V, F <sub>VCO</sub> = 100MHz, C <sub>L</sub> = 15pF	160	250	mA
		V <sub>DDQ</sub> = 1.8V, F <sub>VCO</sub> = 250MHz, C <sub>L</sub> = 15pF	270	400	

### NOTES:

1. These power consumption characteristics are for all the valid input interfaces and cover the worst case input and output interface combinations.
2. The termination resistors are excluded from these measurements.
3. If the differential input interface is used, the true input is held LOW and the complementary input is held HIGH.
4. Bit 60 = 1.
5. All outputs are at the same interface level.

## DIFFERENTIAL INPUT AC TEST CONDITIONS FOR eHSTL

Symbol	Parameter	Value	Units
V <sub>DIF</sub>	Input Signal Swing <sup>(1)</sup>	1	V
V <sub>X</sub>	Differential Input Signal Crossing Point <sup>(2)</sup>	900	mV
V <sub>THI</sub>	Input Timing Measurement Reference Level <sup>(3)</sup>	Crossing Point	V
t <sub>R</sub> , t <sub>F</sub>	Input Signal Edge Rate <sup>(4)</sup>	1	V/ns

### NOTES:

1. The 1V peak-to-peak input pulse level is specified to allow consistent, repeatable results in an automatic test equipment (ATE) environment. This device meets the V<sub>DIF</sub> (AC) specification under actual use conditions.
2. A 900mV crossing point level is specified to allow consistent, repeatable results in an automatic test equipment (ATE) environment. This device meets the V<sub>X</sub> specification under actual use conditions.
3. In all cases, input waveform timing is marked at the differential cross-point of the input signals.
4. The input signal edge rate of 1V/ns or greater is to be maintained in the 20% to 80% range of the input waveform.

## DC ELECTRICAL CHARACTERISTICS OVER OPERATING RANGE FOR LVEPECL<sup>(1)</sup>

Symbol	Parameter	Test Conditions	Min.	Typ. <sup>(2)</sup>	Max	Unit
<b>Input Characteristics</b>						
I <sub>IH</sub>	Input HIGH Current	V <sub>DD</sub> = 2.7V V <sub>I</sub> = V <sub>DDQDN</sub> /GND	—	—	±5	μA
I <sub>IL</sub>	Input LOW Current	V <sub>DD</sub> = 2.7V V <sub>I</sub> = GND/V <sub>DDQDN</sub>	—	—	±5	
V <sub>IK</sub>	Clamp Diode Voltage	V <sub>DD</sub> = 2.3V, I <sub>IN</sub> = -18mA	—	-0.7	-1.2	V
V <sub>IN</sub>	DC Input Voltage		-0.3	—	3.6	V
V <sub>CM</sub>	DC Common Mode Input Voltage <sup>(3,5)</sup>		915	1082	1248	mV
V <sub>REF</sub>	Single-Ended Reference Voltage <sup>(4,5)</sup>		—	1082	—	mV
V <sub>IH</sub>	DC Input HIGH		1275	—	1620	mV
V <sub>IL</sub>	DC Input LOW		555	—	875	mV

**NOTES:**

1. See RECOMMENDED OPERATING RANGE table.
2. Typical values are at V<sub>DD</sub> = 2.5V, +25°C ambient.
3. V<sub>CM</sub> specifies the maximum allowable range of (V<sub>TR</sub> + V<sub>CP</sub>) /2. Differential mode only.
4. For single-ended operation while in differential mode, REF<sub>[1:0]</sub>/VREF<sub>[1:0]</sub> is tied to the DC voltage VREF<sub>[1:0]</sub>.
5. The reference clock input is capable of HSTL, eHSTL, LVEPECL, 1.8V or 2.5V LVTTTL operation independent of the device output. (See Input/Output Selection table.)

## DIFFERENTIAL INPUT AC TEST CONDITIONS FOR LVEPECL

Symbol	Parameter	Value	Units
V <sub>DIF</sub>	Input Signal Swing <sup>(1)</sup>	732	mV
V <sub>X</sub>	Differential Input Signal Crossing Point <sup>(2)</sup>	1082	mV
V <sub>THI</sub>	Input Timing Measurement Reference Level <sup>(3)</sup>	Crossing Point	V
t <sub>R</sub> , t <sub>F</sub>	Input Signal Edge Rate <sup>(4)</sup>	1	V/ns

**NOTES:**

1. The 732mV peak-to-peak input pulse level is specified to allow consistent, repeatable results in an automatic test equipment (ATE) environment. This device meets the V<sub>DIF</sub> (AC) specification under actual use conditions.
2. A 1082mV crossing point level is specified to allow consistent, repeatable results in an automatic test equipment (ATE) environment. This device meets the V<sub>X</sub> specification under actual use conditions.
3. In all cases, input waveform timing is marked at the differential cross-point of the input signals.
4. The input signal edge rate of 1V/ns or greater is to be maintained in the 20% to 80% range of the input waveform.

## DC ELECTRICAL CHARACTERISTICS OVER OPERATING RANGE FOR 2.5V LVTTTL<sup>(1)</sup>

Symbol	Parameter	Test Conditions	Min.	Typ. <sup>(8)</sup>	Max	Unit
<b>Input Characteristics</b>						
I <sub>IH</sub>	Input HIGH Current	V <sub>DD</sub> = 2.7V V <sub>I</sub> = V <sub>DDQ</sub> /GND	—	—	±5	μA
I <sub>IL</sub>	Input LOW Current	V <sub>DD</sub> = 2.7V V <sub>I</sub> = GND/V <sub>DDQ</sub>	—	—	±5	
V <sub>IK</sub>	Clamp Diode Voltage	V <sub>DD</sub> = 2.3V, I <sub>IN</sub> = -18mA	—	-0.7	-1.2	V
V <sub>IN</sub>	DC Input Voltage		-0.3		+3.6	V
<b>Single-Ended Inputs<sup>(2)</sup></b>						
V <sub>IH</sub>	DC Input HIGH		1.7		—	V
V <sub>IL</sub>	DC Input LOW		—		0.7	V
<b>Differential Inputs</b>						
V <sub>DIF</sub>	DC Differential Voltage <sup>(3,9)</sup>		0.2		—	V
V <sub>CM</sub>	DC Common Mode Input Voltage <sup>(4,9)</sup>		1150	1250	1350	mV
V <sub>IH</sub>	DC Input HIGH <sup>(5,6,9)</sup>		V <sub>REF</sub> + 100		—	mV
V <sub>IL</sub>	DC Input LOW <sup>(5,7,9)</sup>		—		V <sub>REF</sub> - 100	mV
V <sub>REF</sub>	Single-Ended Reference Voltage <sup>(5,9)</sup>		—	1250	—	mV
<b>Output Characteristics</b>						
V <sub>OH</sub>	Output HIGH Voltage	I <sub>OH</sub> = -12mA	V <sub>DDQ</sub> - 0.4		—	V
		I <sub>OH</sub> = -100μA	V <sub>DDQ</sub> - 0.1		—	V
V <sub>OL</sub>	Output LOW Voltage	I <sub>OL</sub> = 12mA	—		0.4	V
		I <sub>OL</sub> = 100μA	—		0.1	V

**NOTES:**

- See RECOMMENDED OPERATING RANGE table.
- For 2.5V LVTTTL single-ended operation, Bits 35/34, 33/32, 31/30 = 0/1 or 1/0, and  $\overline{\text{REF}}_{[1:0]}/V_{\text{REF}[1:0]}$  is left floating. If Bits 47 - 36 = 0,  $\overline{\text{FB}}/V_{\text{REF}2}$  should be left floating.
- V<sub>DIF</sub> specifies the minimum input differential voltage (V<sub>TR</sub> - V<sub>CP</sub>) required for switching where V<sub>TR</sub> is the "true" input level and V<sub>CP</sub> is the "complement" input level. Differential mode only. The DC differential voltage must be maintained to guarantee retaining the existing HIGH or LOW input. The AC differential voltage must be achieved to guarantee switching to a new state.
- V<sub>CM</sub> specifies the maximum allowable range of (V<sub>TR</sub> + V<sub>CP</sub>) / 2. Differential mode only.
- For single-ended operation, in differential mode,  $\overline{\text{REF}}_{[1:0]}/V_{\text{REF}[1:0]}$  is tied to the DC voltage V<sub>REF[1:0]</sub>.
- Voltage required to maintain a logic HIGH, single-ended operation in differential mode.
- Voltage required to maintain a logic LOW, single-ended operation in differential mode.
- Typical values are at V<sub>DD</sub> = 2.5V, V<sub>DDQ</sub> = V<sub>DD</sub>, +25°C ambient.
- The reference clock input is capable of HSTL, eHSTL, LVEPECL, 1.8V or 2.5V LVTTTL operation independent of the device output. (See Input/Output Selection table.)

## POWER SUPPLY CHARACTERISTICS FOR 2.5V LVTTTL OUTPUTS<sup>(1)</sup>

Symbol	Parameter	Test Conditions <sup>(2)</sup>	Typ.	Max	Unit
I <sub>DDQ</sub>	Quiescent V <sub>DD</sub> Power Supply Current <sup>(3)</sup>	V <sub>DDQ</sub> = Max., REF = LOW, $\overline{PD}$ = HIGH, $\overline{nSOE}$ = LOW, PLL_EN = HIGH, Outputs enabled, All outputs unloaded	112	150	mA
I <sub>DDOQ</sub>	Quiescent V <sub>DDQ</sub> Power Supply Current <sup>(3)</sup>	V <sub>DDQ</sub> = Max., REF = LOW, $\overline{PD}$ = HIGH, $\overline{nSOE}$ = LOW, PLL_EN = HIGH, Outputs enabled, All outputs unloaded	15	75	μA
I <sub>DDPD</sub>	Power Down Current	V <sub>DD</sub> = Max., $\overline{PD}$ = LOW, $\overline{nSOE}$ = LOW, PLL_EN = HIGH	0.3	3	mA
I <sub>DDD</sub>	Dynamic V <sub>DD</sub> Power Supply Current per Output	V <sub>DD</sub> = Max., V <sub>DDQ</sub> = Max., C <sub>L</sub> = 0pF	21	30	μA/MHz
I <sub>DDQ</sub>	Dynamic V <sub>DDQ</sub> Power Supply Current per Output	V <sub>DD</sub> = Max., V <sub>DDQ</sub> = Max., C <sub>L</sub> = 0pF	33	40	μA/MHz
I <sub>TOT</sub>	Total Power V <sub>DD</sub> Supply Current <sup>(4,5)</sup>	V <sub>DDQ</sub> = 2.5V., F <sub>VCO</sub> = 100MHz, C <sub>L</sub> = 15pF	280	400	mA
		V <sub>DDQ</sub> = 2.5V., F <sub>VCO</sub> = 250MHz, C <sub>L</sub> = 15pF	320	450	
I <sub>TOTO</sub>	Total Power V <sub>DDQ</sub> Supply Current <sup>(4,5)</sup>	V <sub>DDQ</sub> = 2.5V., F <sub>VCO</sub> = 100MHz, C <sub>L</sub> = 15pF	210	320	mA
		V <sub>DDQ</sub> = 2.5V., F <sub>VCO</sub> = 250MHz, C <sub>L</sub> = 15pF	345	530	

### NOTES:

1. These power consumption characteristics are for all the valid input interfaces and cover the worst case input and output interface combinations.
2. The termination resistors are excluded from these measurements.
3. If the differential input interface is used, the true input is held LOW and the complementary input is held HIGH.
4. Bit 60 = 1.
5. All outputs are at the same interface level.

## DIFFERENTIAL INPUT AC TEST CONDITIONS FOR 2.5V LVTTTL

Symbol	Parameter	Value	Units
V <sub>DIF</sub>	Input Signal Swing <sup>(1)</sup>	V <sub>DD</sub>	V
V <sub>X</sub>	Differential Input Signal Crossing Point <sup>(2)</sup>	V <sub>DD</sub> /2	V
V <sub>THI</sub>	Input Timing Measurement Reference Level <sup>(3)</sup>	Crossing Point	V
t <sub>R</sub> , t <sub>F</sub>	Input Signal Edge Rate <sup>(4)</sup>	2.5	V/ns

### NOTES:

1. A nominal 2.5V peak-to-peak input pulse level is specified to allow consistent, repeatable results in an automatic test equipment (ATE) environment. This device meets the V<sub>DIF</sub> (AC) specification under actual use conditions.
2. A nominal 1.25V crossing point level is specified to allow consistent, repeatable results in an automatic test equipment (ATE) environment. This device meets the V<sub>X</sub> specification under actual use conditions.
3. In all cases, input waveform timing is marked at the differential cross-point of the input signals.
4. The input signal edge rate of 2.5V/ns or greater is to be maintained in the 20% to 80% range of the input waveform.

## SINGLE-ENDED INPUT AC TEST CONDITIONS FOR 2.5V LVTTTL

Symbol	Parameter	Value	Units
V <sub>IH</sub>	Input HIGH Voltage	V <sub>DD</sub>	V
V <sub>IL</sub>	Input LOW Voltage	0	V
V <sub>THI</sub>	Input Timing Measurement Reference Level <sup>(1)</sup>	V <sub>DD</sub> /2	V
t <sub>R</sub> , t <sub>F</sub>	Input Signal Edge Rate <sup>(2)</sup>	2	V/ns

### NOTES:

1. A nominal 1.25V timing measurement reference level is specified to allow constant, repeatable results in an automatic test equipment (ATE) environment.
2. The input signal edge rate of 2V/ns or greater is to be maintained in the 10% to 90% range of the input waveform.



## DC ELECTRICAL CHARACTERISTICS OVER OPERATING RANGE FOR 1.8V LVTTTL<sup>(1)</sup>

Symbol	Parameter	Test Conditions	Min.	Typ. <sup>(8)</sup>	Max	Unit
<b>Input Characteristics</b>						
I <sub>IH</sub>	Input HIGH Current	V <sub>DD</sub> = 2.7V V <sub>I</sub> = V <sub>DDQ</sub> /GND	—	—	±5	μA
I <sub>IL</sub>	Input LOW Current	V <sub>DD</sub> = 2.7V V <sub>I</sub> = GND/V <sub>DDQ</sub>	—	—	±5	
V <sub>IK</sub>	Clamp Diode Voltage	V <sub>DD</sub> = 2.3V, I <sub>IN</sub> = -18mA	—	-0.7	-1.2	V
V <sub>IN</sub>	DC Input Voltage		-0.3		V <sub>DDQ</sub> + 0.3	V
<b>Single-Ended Inputs<sup>(2)</sup></b>						
V <sub>IH</sub>	DC Input HIGH		1.073 <sup>(10)</sup>		—	V
V <sub>IL</sub>	DC Input LOW		—		0.683 <sup>(11)</sup>	V
<b>Differential Inputs</b>						
V <sub>DIF</sub>	DC Differential Voltage <sup>(3,9)</sup>		0.2		—	V
V <sub>CM</sub>	DC Common Mode Input Voltage <sup>(4,9)</sup>		825	900	975	mV
V <sub>IH</sub>	DC Input HIGH <sup>(5,6,9)</sup>		V <sub>REF</sub> + 100		—	mV
V <sub>IL</sub>	DC Input LOW <sup>(5,7,9)</sup>		—		V <sub>REF</sub> - 100	mV
V <sub>REF</sub>	Single-Ended Reference Voltage <sup>(5,9)</sup>		—	900	—	mV
<b>Output Characteristics</b>						
V <sub>OH</sub>	Output HIGH Voltage	I <sub>OH</sub> = -6mA	V <sub>DDQ</sub> - 0.4		—	V
		I <sub>OH</sub> = -100μA	V <sub>DDQ</sub> - 0.1		—	V
V <sub>OL</sub>	Output LOW Voltage	I <sub>OL</sub> = 6mA	—		0.4	V
		I <sub>OL</sub> = 100μA	—		0.1	V

### NOTES:

- See RECOMMENDED OPERATING RANGE table.
- For 1.8V LVTTTL single-ended operation, Bits 35 - 30 = 0 and  $\overline{\text{REF}}_{[1:0]}/V_{\text{REF}[1:0]}$  is left floating. If Bits 47/46, 45/44, 43/42, 41/40, 39/38, 37/36 = 0/1,  $\overline{\text{FB}}/V_{\text{REF}2}$  should be left floating.
- V<sub>DIF</sub> specifies the minimum input differential voltage (V<sub>TR</sub> - V<sub>CP</sub>) required for switching where V<sub>TR</sub> is the "true" input level and V<sub>CP</sub> is the "complement" input level. Differential mode only. The DC differential voltage must be maintained to guarantee retaining the existing HIGH or LOW input. The AC differential voltage must be achieved to guarantee switching to a new state.
- V<sub>CM</sub> specifies the maximum allowable range of (V<sub>TR</sub> + V<sub>CP</sub>) / 2. Differential mode only.
- For single-ended operation in differential mode,  $\overline{\text{REF}}_{[1:0]}/V_{\text{REF}[1:0]}$  is tied to the DC voltage V<sub>REF[1:0]}</sub>. The input is guaranteed to toggle within ±200mV of V<sub>REF[1:0]}</sub> when V<sub>REF[1:0]}</sub> is constrained within +600mV and V<sub>DDI</sub>-600mV, where V<sub>DDI</sub> is the nominal 1.8V power supply of the device driving the REF[1:0] input. To guarantee switching in voltage range specified in the JEDEC 1.8V LVTTTL interface specification, V<sub>REF[1:0]}</sub> must be maintained at 900mV with appropriate tolerances.
- Voltage required to maintain a logic HIGH, single-ended operation in differential mode.
- Voltage required to maintain a logic LOW, single-ended operation in differential mode.
- Typical values are at V<sub>DD</sub> = 2.5V, V<sub>DDQ</sub> = 1.8V, +25°C ambient.
- The reference clock input is capable of HSTL, eHSTL, LVEPECL, 1.8V or 2.5V LVTTTL operation independent of the device output. (See Input/Output Selection table.)
- This value is the worst case minimum V<sub>IH</sub> over the specification range of the 1.8V power supply. The 1.8V LVTTTL specification is V<sub>IH</sub> = 0.65 \* V<sub>DD</sub> where V<sub>DD</sub> is 1.8V ± 0.15V. However, the LVTTTL translator is supplied by a 2.5V nominal supply on this part. To ensure compliance with the specification, the translator was designed to accept the calculated worst case value ( V<sub>IH</sub> = 0.65 \* [1.8 - 0.15V]) rather than reference against a nominal 1.8V supply.
- This value is the worst case maximum V<sub>IL</sub> over the specification range of the 1.8V power supply. The 1.8V LVTTTL specification is V<sub>IL</sub> = 0.35 \* V<sub>DD</sub> where V<sub>DD</sub> is 1.8V ± 0.15V. However, the LVTTTL translator is supplied by a 2.5V nominal supply on this part. To ensure compliance with the specification, the translator was designed to accept the calculated worst case value ( V<sub>IL</sub> = 0.35 \* [1.8 + 0.15V]) rather than reference against a nominal 1.8V supply.

## POWER SUPPLY CHARACTERISTICS FOR 1.8V LVTTTL OUTPUTS<sup>(1)</sup>

Symbol	Parameter	Test Conditions <sup>(2)</sup>	Typ.	Max	Unit
I <sub>DDO</sub>	Quiescent V <sub>DD</sub> Power Supply Current <sup>(3)</sup>	V <sub>DDON</sub> = Max., REF = LOW, $\overline{PD}$ = HIGH, $\overline{nSOE}$ = LOW, $\overline{PLL\_EN}$ = HIGH, Outputs enabled, All outputs unloaded	112	150	mA
I <sub>DDOQ</sub>	Quiescent V <sub>DDON</sub> Power Supply Current <sup>(3)</sup>	V <sub>DDON</sub> = Max., REF = LOW, $\overline{PD}$ = HIGH, $\overline{nSOE}$ = LOW, $\overline{PLL\_EN}$ = HIGH, Outputs enabled, All outputs unloaded	2	75	μA
I <sub>DDPD</sub>	Power Down Current	V <sub>DD</sub> = Max., $\overline{PD}$ = LOW, $\overline{nSOE}$ = LOW, $\overline{PLL\_EN}$ = HIGH	0.3	3	mA
I <sub>DDD</sub>	Dynamic V <sub>DD</sub> Power Supply Current per Output	V <sub>DD</sub> = Max., V <sub>DDON</sub> = Max., C <sub>L</sub> = 0pF	19	30	μA/MHz
I <sub>DDOQ</sub>	Dynamic V <sub>DDON</sub> Power Supply Current per Output	V <sub>DD</sub> = Max., V <sub>DDON</sub> = Max., C <sub>L</sub> = 0pF	22	30	μA/MHz
I <sub>TOT</sub>	Total Power V <sub>DD</sub> Supply Current <sup>(4,5)</sup>	V <sub>DDON</sub> = 1.8V., F <sub>VCO</sub> = 100MHz, C <sub>L</sub> = 15pF	275	400	mA
		V <sub>DDON</sub> = 1.8V., F <sub>VCO</sub> = 250MHz, C <sub>L</sub> = 15pF	310	450	
I <sub>TOTO</sub>	Total Power V <sub>DDON</sub> Supply Current <sup>(4,5)</sup>	V <sub>DDON</sub> = 1.8V., F <sub>VCO</sub> = 100MHz, C <sub>L</sub> = 15pF	135	200	mA
		V <sub>DDON</sub> = 1.8V., F <sub>VCO</sub> = 250MHz, C <sub>L</sub> = 15pF	200	300	

### NOTES:

- These power consumption characteristics are for all the valid input interfaces and cover the worst case input and output interface combinations.
- The termination resistors are excluded from these measurements.
- If the differential input interface is used, the true input is held LOW and the complementary input is held HIGH.
- Bit 60 = 1.
- All outputs are at the same interface level.

## DIFFERENTIAL INPUT AC TEST CONDITIONS FOR 1.8V LVTTTL

Symbol	Parameter	Value	Units
V <sub>DIF</sub>	Input Signal Swing <sup>(1)</sup>	V <sub>DDI</sub>	V
V <sub>X</sub>	Differential Input Signal Crossing Point <sup>(2)</sup>	V <sub>DDI</sub> /2	mV
V <sub>THI</sub>	Input Timing Measurement Reference Level <sup>(3)</sup>	Crossing Point	V
t <sub>R</sub> , t <sub>F</sub>	Input Signal Edge Rate <sup>(4)</sup>	1.8	V/ns

### NOTES:

- V<sub>DDI</sub> is the nominal 1.8V supply (1.8V ± 0.15V) of the part or source driving the input. A nominal 1.8V peak-to-peak input pulse level is specified to allow consistent, repeatable results in an automatic test equipment (ATE) environment. This device meets the V<sub>DIF</sub> (AC) specification under actual use conditions.
- A nominal 900mV crossing point level is specified to allow consistent, repeatable results in an automatic test equipment (ATE) environment. This device meets the V<sub>X</sub> specification under actual use conditions.
- In all cases, input waveform timing is marked at the differential cross-point of the input signals.
- The input signal edge rate of 1.8V/ns or greater is to be maintained in the 20% to 80% range of the input waveform.

## SINGLE-ENDED INPUT AC TEST CONDITIONS FOR 1.8V LVTTTL

Symbol	Parameter	Value	Units
V <sub>IH</sub>	Input HIGH Voltage <sup>(1)</sup>	V <sub>DDI</sub>	V
V <sub>IL</sub>	Input LOW Voltage	0	V
V <sub>THI</sub>	Input Timing Measurement Reference Level <sup>(2)</sup>	V <sub>DDI</sub> /2	mV
t <sub>R</sub> , t <sub>F</sub>	Input Signal Edge Rate <sup>(3)</sup>	2	V/ns

### NOTES:

- V<sub>DDI</sub> is the nominal 1.8V supply (1.8V ± 0.15V) of the part or source driving the input.
- A nominal 900mV timing measurement reference level is specified to allow constant, repeatable results in an automatic test equipment (ATE) environment.
- The input signal edge rate of 2V/ns or greater is to be maintained in the 10% to 90% range of the input waveform.

## AC ELECTRICAL CHARACTERISTICS OVER OPERATING RANGE

All outputs at the same interface level

Symbol	Parameter	Min.	Typ.	Max	Unit	
F <sub>NOM</sub>	VCO Frequency Range	see JTAG/I <sup>2</sup> C Serial Configurations: VCO Frequency Range table				
t <sub>RPW</sub>	Reference Clock Pulse Width HIGH or LOW	1	—	—	ns	
t <sub>FPW</sub>	Feedback Input Pulse Width HIGH or LOW	1	—	—	ns	
t <sub>u</sub>	Programmable Skew Time Unit	see Control Summary Table				
t <sub>SK(O)</sub>	Output Skew (Rise-Rise, Fall-Fall, Nominal) <sup>(1,2)</sup>	—	—	100	ps	
t <sub>SK1(ω)</sub>	Multiple Frequency Skew (Rise-Rise, Fall-Fall, Nominal-Divided, Divided-Divided) <sup>(1,2,3)</sup>	—	—	100	ps	
t <sub>SK2(ω)</sub>	Multiple Frequency Skew (Rise-Fall, Nominal-Divided, Divided-Divided) <sup>(1,2,3)</sup>	—	—	300	ps	
t <sub>SK1(INV)</sub>	Inverting Skew (Nominal-Inverted) <sup>(1,2)</sup>	—	—	300	ps	
t <sub>SK2(INV)</sub>	Inverting Skew (Rise-Rise, Fall-Fall, Rise-Fall, Inverted-Divided) <sup>(1,2,3)</sup>	—	—	300	ps	
t <sub>SK(PR)</sub>	Process Skew <sup>(1,2,4)</sup>	—	—	300	ps	
t(φ)	REF Input to FB Static Phase Offset <sup>(5)</sup>	-100	—	100	ps	
t <sub>ODCV</sub>	Output Duty Cycle Variation from 50% <sup>(11,12)</sup>	1.8V LVTTTL	-375	—	375	ps
		2.5V LVTTTL	-275	—	275	
t <sub>ORISE</sub>	Output Rise Time <sup>(6)</sup>	HSTL / eHSTL / 1.8V LVTTTL	—	—	1.2	ns
		2.5V LVTTTL	—	—	1	
t <sub>OFALL</sub>	Output Fall Time <sup>(6)</sup>	HSTL / eHSTL / 1.8V LVTTTL	—	—	1.2	ns
		2.5V LVTTTL	—	—	1	
t <sub>L</sub>	Power-up PLL Lock Time <sup>(7)</sup>	—	—	4	ms	
t <sub>L(ω)</sub>	PLL Lock Time After Input Frequency Change <sup>(7)</sup>	—	—	1	ms	
t <sub>L(PD)</sub>	PLL Lock Time After Asserting $\overline{PD}$ Pin <sup>(7)</sup>	—	—	1	ms	
t <sub>L(REFSEL1)</sub>	PLL Lock Time After Change in REF_SEL <sup>(7,9)</sup>	—	—	100	μs	
t <sub>L(REFSEL2)</sub>	PLL Lock Time After Change in REF_SEL (REF <sub>1</sub> and REF <sub>0</sub> are different frequency) <sup>(7)</sup>	—	—	1	ms	
t <sub>JT(CC)</sub>	Cycle-to-Cycle Output Jitter (peak-to-peak) <sup>(2,8)</sup>	—	50	75	ps	
t <sub>JT(PER)</sub>	Period Jitter (peak-to-peak) <sup>(2,8)</sup>	—	—	75	ps	
t <sub>JT(HP)</sub>	Half Period Jitter (peak-to-peak) <sup>(2,8,10)</sup>	—	—	125	ps	
t <sub>JT(DUTY)</sub>	Duty Cycle Jitter (peak-to-peak) <sup>(2,8)</sup>	—	—	100	ps	
V <sub>OX</sub>	HSTL and eHSTL Differential True and Complementary Output Crossing Voltage Level	V <sub>DDON</sub> /2 - 150	V <sub>DDON</sub> /2	V <sub>DDON</sub> /2 + 150	mV	

## NOTES:

- Skew is the time between the earliest and latest output transition among all outputs for which the same t<sub>u</sub> delay has been selected, when all outputs are loaded with the specified load.
- For differential LVTTTL outputs, the measurement is made at V<sub>DDON</sub>/2, where the true outputs are only compared with other true outputs and the complementary outputs are only compared to other complementary outputs. For differential HSTL/eHSTL outputs, the measurement is made at the crossing point (V<sub>OX</sub>) of the true and complementary signals.
- There are three classes of outputs: nominal (multiple of t<sub>u</sub> delay), inverted, and divided (divide-by-2 or divide-by-4 mode).
- t<sub>SK(PR)</sub> is the output to corresponding output skew between any two devices operating under the same conditions (V<sub>DD</sub> and V<sub>DDON</sub>, ambient temperature, air flow, etc.).
- t(φ) is measured with REF and FB the same type of input, the same rise and fall times. For 1.8V / 2.5V LVTTTL input and output, the measurement is taken from V<sub>THI</sub> on REF to V<sub>THI</sub> on FB. For HSTL / eHSTL input and output, the measurement is taken from the crosspoint of REF/REF to the crosspoint of FB/FB. All outputs are set to 0t<sub>u</sub>, FB input divider is set to divide-by-one, and Bit 60 = 1.
- Output rise and fall times are measured between 20% to 80% of the actual output voltage swing.
- t<sub>L</sub>, t<sub>L(ω)</sub>, t<sub>L(REFSEL1)</sub>, t<sub>L(REFSEL2)</sub>, and t<sub>L(PD)</sub> are the times that are required before the synchronization is achieved. These specifications are valid only after V<sub>DD</sub>/V<sub>DDON</sub> is stable and within the normal operating limits. These parameters are measured from the application of a new signal at REF or FB, or after  $\overline{PD}$  is (re)asserted until t(φ) is within specified limits.
- The jitter parameters are measured with all outputs selected for 0t<sub>u</sub>, FB input divider is set to divide-by-one, and Bit 60 = 1.
- Both REF inputs must be the same frequency, but up to ±180° out of phase.
- For HSTL/eHSTL outputs only.
- For LVTTTL outputs only.
- t<sub>ODCV</sub> is measured with all outputs selected for zero delay.

## AC ELECTRICAL CHARACTERISTICS OVER OPERATING RANGE

All outputs at the different interface levels

Symbol	Parameter	Min.	Typ.	Max	Unit	
F <sub>NOM</sub>	VCO Frequency Range	see JTAG/I <sup>2</sup> C Serial Configurations: VCO Frequency Range table				
t <sub>RPW</sub>	Reference Clock Pulse Width HIGH or LOW	1	—	—	ns	
t <sub>FPW</sub>	Feedback Input Pulse Width HIGH or LOW	1	—	—	ns	
t <sub>u</sub>	Programmable Skew Time Unit	see Control Summary Table				
t <sub>SK(O)</sub>	Output Skew (Rise-Rise, Fall-Fall, Nominal) <sup>(1,2)</sup>	—	—	250	ps	
t <sub>SK1(ω)</sub>	Multiple Frequency Skew (Rise-Rise, Fall-Fall, Nominal-Divided, Divided-Divided) <sup>(1,2,3)</sup>	—	—	500	ps	
t <sub>SK2(ω)</sub>	Multiple Frequency Skew (Rise-Fall, Nominal-Divided, Divided-Divided) <sup>(1,2,3)</sup>	—	—	500	ps	
t <sub>SK1(INV)</sub>	Inverting Skew (Nominal-Inverted) <sup>(1,2)</sup>	—	—	500	ps	
t <sub>SK2(INV)</sub>	Inverting Skew (Rise-Rise, Fall-Fall, Rise-Fall, Inverted-Divided) <sup>(1,2,3)</sup>	—	—	500	ps	
t <sub>SK(PR)</sub>	Process Skew <sup>(1,2,4)</sup>	—	—	400	ps	
t(φ)	REF Input to FB Static Phase Offset <sup>(5)</sup>	-200	—	200	ps	
t <sub>ODCV</sub>	Output Duty Cycle Variation from 50% <sup>(11,12)</sup>	1.8V LVTTTL	-475	—	475	ps
		2.5V LVTTTL	-375	—	375	
t <sub>ORISE</sub>	Output Rise Time <sup>(6)</sup>	HSTL / eHSTL / 1.8V LVTTTL	—	—	1.2	ns
		2.5V LVTTTL	—	—	1	
t <sub>OFALL</sub>	Output Fall Time <sup>(6)</sup>	HSTL / eHSTL / 1.8V LVTTTL	—	—	1.2	ns
		2.5V LVTTTL	—	—	1	
t <sub>L</sub>	Power-up PLL Lock Time <sup>(7)</sup>	—	—	4	ms	
t <sub>L(ω)</sub>	PLL Lock Time After Input Frequency Change <sup>(7)</sup>	—	—	1	ms	
t <sub>L(PD)</sub>	PLL Lock Time After Asserting $\overline{\text{PD}}$ Pin <sup>(7)</sup>	—	—	1	ms	
t <sub>L(REFSEL1)</sub>	PLL Lock Time After Change in REF_SEL <sup>(7,9)</sup>	—	—	100	μs	
t <sub>L(REFSEL2)</sub>	PLL Lock Time After Change in REF_SEL (REF1 and REF0 are different frequency) <sup>(7)</sup>	—	—	1	ms	
t <sub>JT(CC)</sub>	Cycle-to-Cycle Output Jitter (peak-to-peak) <sup>(2,8)</sup>	—	—	100	ps	
t <sub>JT(PER)</sub>	Period Jitter (peak-to-peak) <sup>(2,8)</sup>	—	—	150	ps	
t <sub>JT(HP)</sub>	Half Period Jitter (peak-to-peak) <sup>(2,8,10)</sup>	—	—	200	ps	
t <sub>JT(DUTY)</sub>	Duty Cycle Jitter (peak-to-peak) <sup>(2,8)</sup>	—	—	150	ps	
V <sub>OX</sub>	HSTL and eHSTL Differential True and Complementary Output Crossing Voltage Level	V <sub>DDQ</sub> /2 - 150	V <sub>DDQ</sub> /2	V <sub>DDQ</sub> /2 + 150	mV	

### NOTES:

- Skew is the time between the earliest and latest output transition among all outputs for which the same t<sub>u</sub> delay has been selected, when all outputs are loaded with the specified load.
- For differential LVTTTL outputs, the measurement is made at V<sub>DDQ</sub>/2, where the true outputs are only compared with other true outputs and the complementary outputs are only compared to other complementary outputs. For differential HSTL/eHSTL outputs, the measurement is made at the crossing point (V<sub>OX</sub>) of the true and complementary signals.
- There are three classes of outputs: nominal (multiple of t<sub>u</sub> delay), inverted, and divided (divide-by-2 or divide-by-4 mode).
- t<sub>SK(PR)</sub> is the output to corresponding output skew between any two devices operating under the same conditions (V<sub>DD</sub> and V<sub>DDQ</sub>, ambient temperature, air flow, etc.).
- t(φ) is measured with REF and FB the same type of input, the same rise and fall times. For 1.8V / 2.5V LVTTTL input and output, the measurement is taken from V<sub>RHI</sub> on REF to V<sub>RHI</sub> on FB. For HSTL / eHSTL input and output, the measurement is taken from the crosspoint of REF/ $\overline{\text{REF}}$  to the crosspoint of FB/ $\overline{\text{FB}}$ . All outputs are set to 0t<sub>u</sub>, FB input divider is set to divide-by-one, and Bit 60 = 1.
- Output rise and fall times are measured between 20% to 80% of the actual output voltage swing.
- t<sub>L(ω)</sub>, t<sub>L(REFSEL1)</sub>, t<sub>L(REFSEL2)</sub>, and t<sub>L(PD)</sub> are the times that are required before the synchronization is achieved. These specifications are valid only after V<sub>DD</sub>/V<sub>DDQ</sub> is stable and within the normal operating limits. These parameters are measured from the application of a new signal at REF or FB, or after PD is (re)asserted until t(φ) is within specified limits.
- The jitter parameters are measured with all outputs selected for 0t<sub>u</sub>, FB input divider is set to divide-by-one, and Bit 60 = 1.
- Both REF inputs must be the same frequency, but up to ±180° out of phase.
- For HSTL/eHSTL outputs only.
- For LVTTTL outputs only.
- t<sub>ODCV</sub> is measured with all outputs selected for zero delay.

## AC DIFFERENTIAL INPUT SPECIFICATIONS<sup>(1)</sup>

Symbol	Parameter	Min.	Typ.	Max	Unit
t <sub>w</sub>	Reference/Feedback Input Clock Pulse Width HIGH or LOW (HSTL/eHSTL outputs) <sup>(2)</sup>	1	—	—	ns
	Reference/Feedback Input Clock Pulse Width HIGH or LOW (2.5V / 1.8V LVTTTL outputs) <sup>(2)</sup>	1	—	—	

### HSTL/eHSTL/1.8V LVTTTL/2.5V LVTTTL

V <sub>DIF</sub>	AC Differential Voltage <sup>(3)</sup>	400	—	—	mV
V <sub>IH</sub>	AC Input HIGH <sup>(4,5)</sup>	V <sub>x</sub> + 200	—	—	mV
V <sub>IL</sub>	AC Input LOW <sup>(4,6)</sup>	—	—	V <sub>x</sub> - 200	mV

### LVEPECL

V <sub>DIF</sub>	AC Differential Voltage <sup>(3)</sup>	400	—	—	mV
V <sub>IH</sub>	AC Input HIGH <sup>(4)</sup>	1275	—	—	mV
V <sub>IL</sub>	AC Input LOW <sup>(4)</sup>	—	—	875	mV

#### NOTES:

- For differential input mode, Bits 35 - 30 = 1.
- Both differential input signals should not be driven to the same level simultaneously. The input will not change state until the inputs have crossed and the voltage range defined by V<sub>DIF</sub> has been met or exceeded.
- Differential mode only. V<sub>DIF</sub> specifies the minimum input voltage (V<sub>TR</sub> - V<sub>CP</sub>) required for switching where V<sub>TR</sub> is the "true" input level and V<sub>CP</sub> is the "complement" input level. The AC differential voltage must be achieved to guarantee switching to a new state.
- For single-ended operation,  $\overline{REF}_{[1:0]}/V_{REF[1:0]}$  is tied to the DC voltage V<sub>REF[1:0]}</sub>. Refer to each input interface's DC specification for the correct V<sub>REF[1:0]}</sub> range.
- Voltage required to switch to a logic HIGH, single-ended operation only.
- Voltage required to switch to a logic LOW, single-ended operation only.

AC TIMING DIAGRAM<sup>(1)</sup>

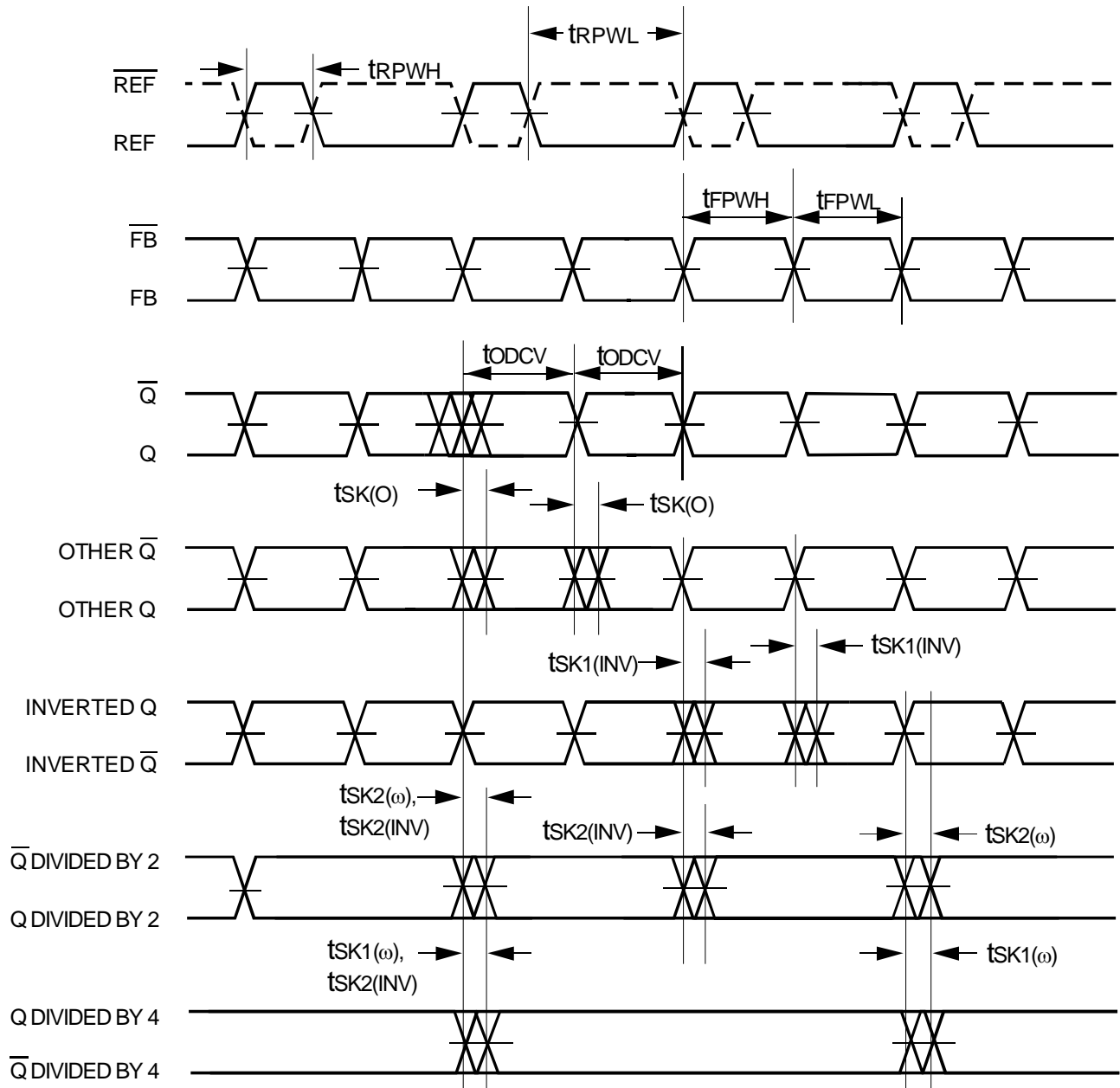

**NOTE:**  
1. The AC TIMING DIAGRAM applies to Bit 58 = 1. For Bit 58 = 0, the negative edge of FB aligns with the negative edge of REF<sub>[1:0]</sub>, divided outputs change on the negative edge of REF<sub>[1:0]</sub>, and the positive edges of the divide-by-2 and divide-by-4 signals align.

## JITTER AND OFFSET TIMING WAVEFORMS

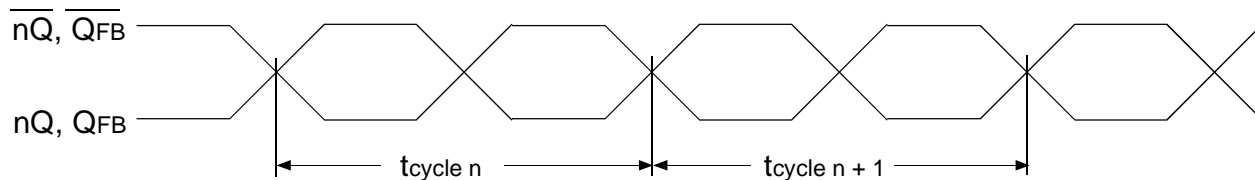

$$t_{jit(cc)} = t_{cycle n} - t_{cycle n+1}$$

*Cycle-to-Cycle jitter*

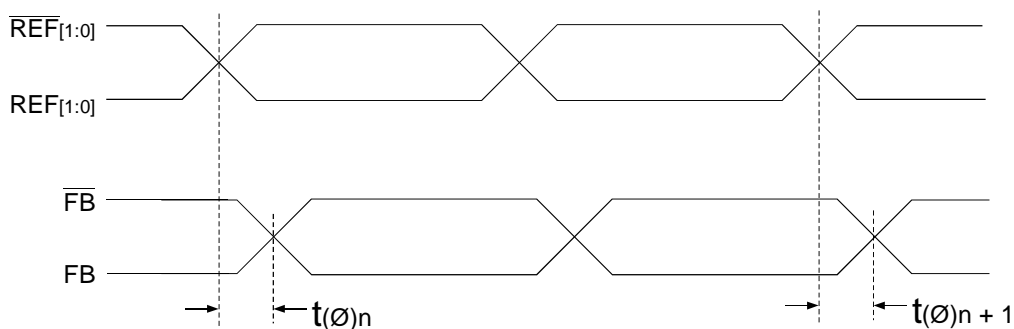

$$t(\emptyset) = \frac{\sum_{n=1}^N t(\emptyset)_n}{N}$$

(N is a large number of samples)

*Static Phase Offset*

**NOTE:**

1. Diagram for Bit 58 = 1 and HSTL / eHSTL input and output.

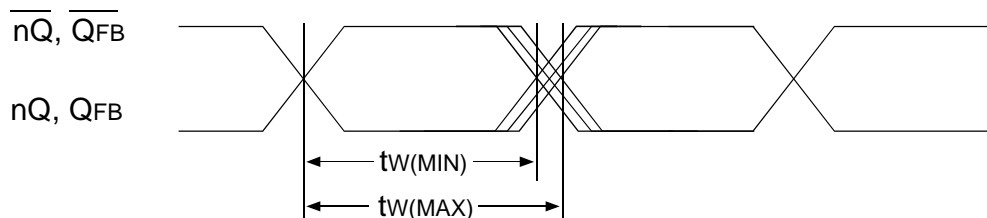

$$t_{JIT(DUTY)} = |t_{w(MAX)} - t_{w(MIN)}|$$

*Duty-Cycle Jitter*

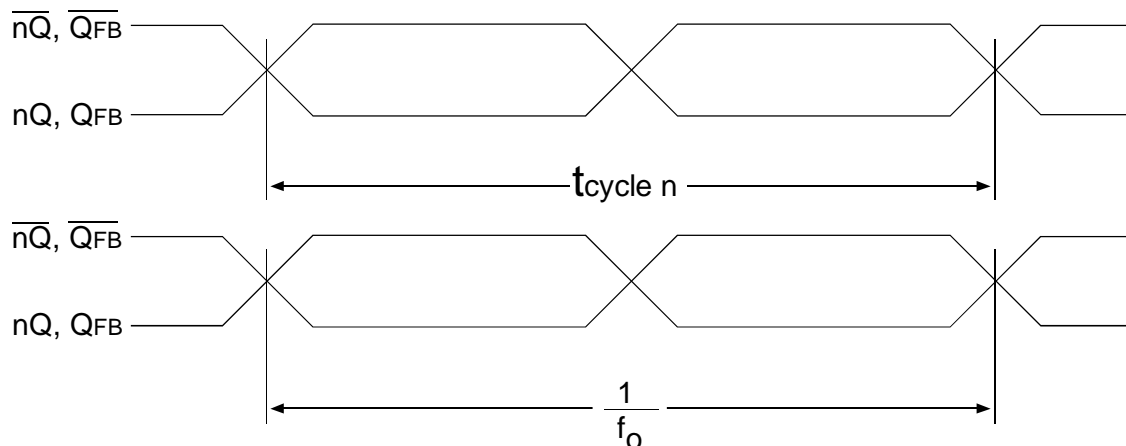

$$t_{jit(per)} = t_{cycle\ n} - \frac{1}{f_o}$$

*Period jitter*

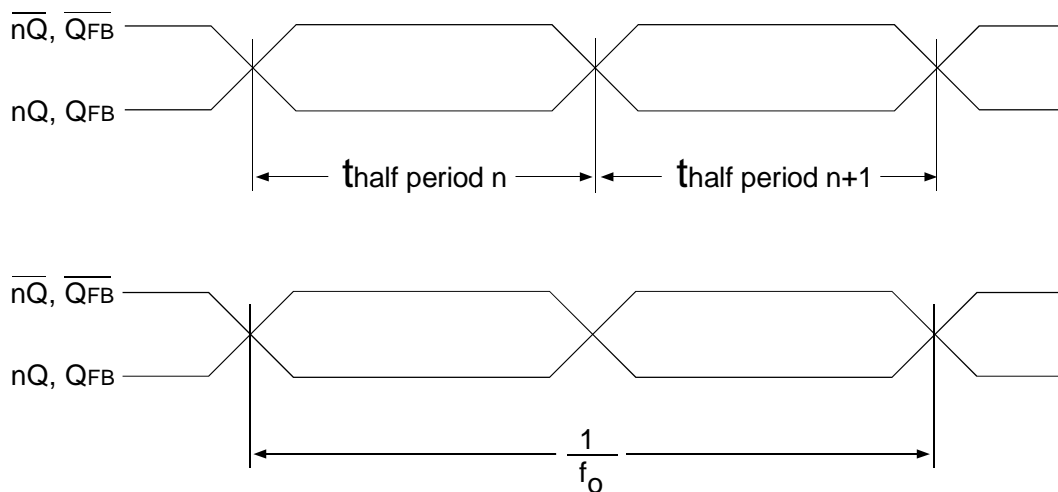

$$t_{jit(hper)} = t_{half\ period\ n} - \frac{1}{2 \cdot f_o}$$

*Half-Period jitter*



### TEST CIRCUITS AND CONDITIONS

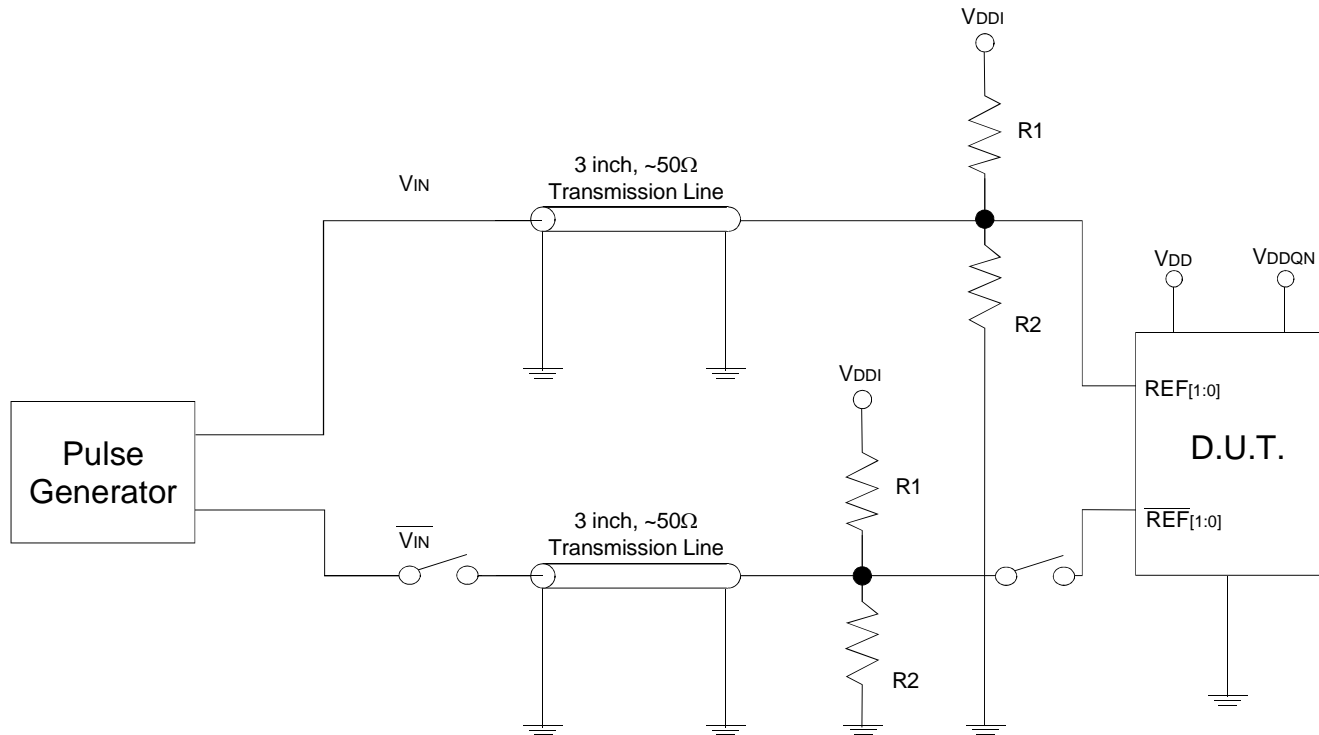

Test Circuit for Differential Input<sup>(1)</sup>

### DIFFERENTIAL INPUT TEST CONDITIONS

Symbol	$V_{DD} = 2.5V \pm 0.2V$	Unit
R1	100	$\Omega$
R2	100	$\Omega$
$V_{DDI}$	$V_{CM} \times 2$	V
$V_{THI}$	HSTL: Crossing of REF[1:0] and $\overline{REF}$ [1:0] eHSTL: Crossing of REF[1:0] and $\overline{REF}$ [1:0] LVEPECL: Crossing of REF[1:0] and $\overline{REF}$ [1:0] 1.8V LVTTTL: $V_{DDI}/2$ 2.5V LVTTTL: $V_{DD}/2$	V

**NOTE:**

1. This input configuration is used for all input interfaces. For single-ended testing, the  $\overline{REF}$ [1:0] must be left floating. For testing single-ended in differential input mode, the  $\overline{V_{IN}}$  should be floating.

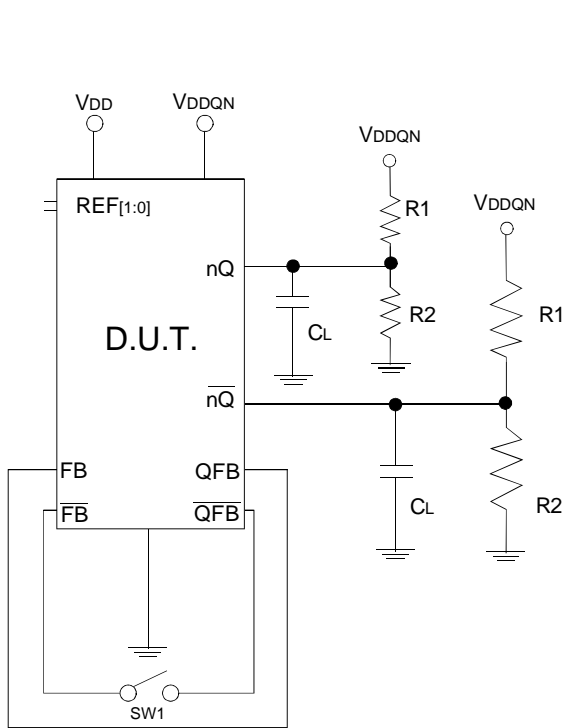

Test Circuit for Differential Outputs

DIFFERENTIAL OUTPUT TEST CONDITIONS

Symbol	$V_{DD} = 2.5V \pm 0.2V$ $V_{DDQN} = \text{Interface Specified}$	Unit
$C_L$	15	pF
R1	100	$\Omega$
R2	100	$\Omega$
$V_{ox}$	HSTL: Crossing of nQ and $\overline{nQ}$ eHSTL: Crossing of nQ and $\overline{nQ}$	V
$V_{THO}$	1.8V LVTTTL: $V_{DDQN}/2$ 2.5V LVTTTL: $V_{DDQN}/2$	V
SW1	1.8V/2.5V LVTTTL	Open
	HSTL/eHSTL	Closed

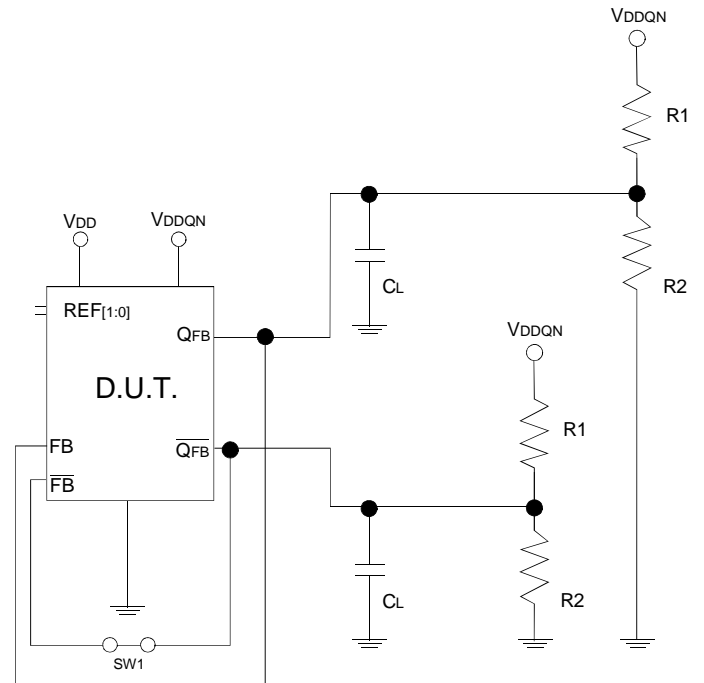

Test Circuit for Differential Feedback

DIFFERENTIAL FEEDBACK TEST CONDITIONS

Symbol	$V_{DD} = 2.5V \pm 0.2V$ $V_{DDQN} = \text{Interface Specified}$	Unit
$C_L$	15	pF
R1	100	$\Omega$
R2	100	$\Omega$
$V_{ox}$	HSTL: Crossing of QFB and $\overline{QFB}$ eHSTL: Crossing of QFB and $\overline{QFB}$	V
$V_{THO}$	1.8V LVTTTL: $V_{DDQN}/2$ 2.5V LVTTTL: $V_{DDQN}/2$	V
SW1	1.8V/2.5V LVTTTL	Open
	HSTL/eHSTL	Closed

## I<sup>2</sup>C SERIAL INTERFACE CONTROL

The I<sup>2</sup>C interface permits the configuration of the IDT5T9891. The IDT5T9891 is a read/write slave device meeting Philips I<sup>2</sup>C bus specifications. The I<sup>2</sup>C bus is controlled by a master device that generates the serial clock SCLK, controls bus access, and generates the START and STOP conditions while the device works as a slave. Both master and slave can operate as a transmitter and receiver but the master device determines which mode is activated.

### BUS CONDITIONS

Data transfer on the bus can only be initiated when the bus is not busy. During data transfer, the data line (SDA) must remain stable whenever the clock line (SCLK) is high. Changes in the data line while the clock line is high will be interpreted by the device as a START or STOP condition. The following bus conditions are defined by the I<sup>2</sup>C bus protocol and are illustrated in figure 1.

### NOT BUSY

Both the data (SDA) and clock (SCLK) lines remain high to indicate the bus is not busy.

### START DATA TRANSFER

A high to low transition of the SDA line while the SCLK input is high indicates a START condition. All commands to the device must be preceded by a START condition.

### STOP DATA TRANSFER

A low to high transition of the SDA line while SCLK is held high indicates a STOP condition. All commands to the device must be followed by a STOP condition.

### DATA VALID

The state of the SDA line represents valid data if the SDA line is stable for the duration of the high period of the SCLK line after a START condition occurs. The data on the SDA line must be changed only during the low period of the SCLK signal. There is one clock pulse per data bit. Each data transfer is initiated by a START condition and terminated with a STOP condition.

### ACKNOWLEDGE

When addressed, the receiving device is required to generate an Acknowledge after each byte is received. The master device must generate an extra clock pulse to coincide with the Acknowledge bit. The acknowledging device must pull the SDA line low during the high period of the master acknowledge clock pulse. Setup and hold times must be taken into account.

### I<sup>2</sup>C BUS OPERATION

The IDT5T9891 I<sup>2</sup>C interface supports Standard-Mode (100kHz) and Fast-Mode (400kHz) data transfer rates. Data is transferred in bytes in sequential order from the lowest to highest byte. After generating a START condition, the bus master broadcasts a 7-bit slave address followed by a read/write bit.

## I<sup>2</sup>C ADDRESS

A7	A6	A5	A4	A3	A2	A1
1	1	0	1	X	X	X

Address A0 is the read/write bit and is set to '0' for writes and '1' for reads. The ADDR0 and ADDR1 tri-level pins allow the last three bits of the 7-bit address to be defined by the user.

ADDR1	ADDR0	A3	A2	A1
LOW	LOW	0	0	0
LOW	MID	0	0	1
LOW	HIGH	0	1	0
MID	LOW	0	1	1
MID	MID	1	0	0
MID	HIGH	1	0	1
HIGH	LOW	1	1	0
HIGH	MID	1	1	1
HIGH	HIGH	1	1	0

### WRITE OPERATION

(see *PC Interface Definition for ProgWrite*)

To initiate a write operation (ProgWrite), the read/write bit is set to '0'. During the write operation, the first two bytes transferred must be the Device Address followed by the Command Code. The internal programming registers of the device ignore these first two bytes. The subsequent bytes are the Data Bytes, which total twelve. All twelve Data Bytes must be written into the device during the write operation in order for the internal programming registers to be updated. If a STOP condition is generated before the 12<sup>th</sup> Data Byte, the internal programming registers will remain unchanged to prevent an invalid PLL configuration. An Acknowledge by the device between each byte must occur before the next byte is sent. After the transfer of the 12<sup>th</sup> Data Byte, an Acknowledge signal will be sent to the bus master after which it will generate a STOP condition. Once the STOP condition has occurred, the internal programming registers of the device will be updated.

### READ OPERATION

(see *PC Interface Definition for ProgRead*)

To initiate a read operation (ProgRead), the read/write bit is set to '1'. During the read operation, there will be a total of fourteen data bytes returned following an Acknowledge of the device address. The first two data bytes are the ID Byte and a Reserved Byte, in that order. The subsequent bytes are the same twelve Data Bytes that were written during the write operation. The read back can be terminated at any time by issuing a STOP condition.

## I<sup>2</sup>C ID BYTE

ID7	ID6	ID5	ID4	ID3	ID2	ID1	ID0
0	0	0	0	0	1	1	1

**EEPROM OPERATION**

*(see I<sup>2</sup>C Interface Definition for the EEPROM instructions)*

The IDT5T9891 can also store its configuration in internal EEPROM. The contents of the device's internal programming registers can be saved to the EEPROM by issuing a save instruction (ProgSave) and can be loaded back to the internal programming registers by issuing a restore instruction (ProgRestore). To initiate a save or restore, only two bytes are transferred. The Device Address is issued with the read/write bit set to '0' followed by the appropriate Command Code. The save or restore instruction executes after the STOP condition is received, during which time the IDT5T9891 will not generate Acknowledge bits. The device is ready to accept a new programming instruction once it Acknowledges its 7-bit address. The time it takes for the save and restore instructions to complete depends on the PLL oscillator frequency, F<sub>VCO</sub>. The restore time, T<sub>RESTORE</sub>, and the save time, T<sub>SAVE</sub>, can be calculated as follows:

$$T_{RESTORE} = 1.23 \times 10^9 / F_{VCO} \quad (\text{mS})$$

$$T_{SAVE} = 3.09 \times 10^9 / F_{VCO} + 52 \quad (\text{mS})$$

In order for the save and restore instructions to function properly, the IDT5T9891 must not be in power-down mode ( $\overline{\text{PD}}$  must be HIGH), and the PLL must be enabled ( $\overline{\text{PLL\_EN}}$  must be LOW and Bit 57 = 0).

On power-up of the IDT5T9891, an automatic restore is performed to load the EEPROM contents into the internal programming registers. The auto-restore will not function properly if the device is in power-down mode ( $\overline{\text{PD}}$  must be HIGH). The device's auto-restore feature will function regardless of the state of the  $\overline{\text{PLL\_EN}}$  pin or Bit 57. The IDT5T9891 will be ready to accept a programming instruction once it acknowledges its 7-bit I<sup>2</sup>C address. The time it takes for the device to complete the auto-restore is approximately 3ms.

**PROGRAMMING NOTES**

Once the IDT5T9891 has been programmed either with a ProgWrite or ProgRestore instruction, the device will attempt to achieve phase lock using the new PLL configuration. If there is a valid REF and FB input clock connected to the device and it does not achieve lock, the user should issue a ProgRead instruction to confirm that the PLL configuration data is valid.

On power-up and before the automatic ProgRestore instruction has completed, the internal programming registers will contain the value of '0' for all bits 95:0. The PLL will remain at the minimum frequency and will not achieve phase lock until after the automatic restore is completed. If the outputs are enabled by the  $\overline{\text{nSOE}}$  pins, the outputs will toggle at the minimum frequency. If the outputs are disabled by the  $\overline{\text{nSOE}}$  pins and the OMODE pin is set HIGH, the nQ and QFB are stopped HIGH, while  $\overline{\text{nQ}}$  and  $\overline{\text{QFB}}$  are stopped LOW.

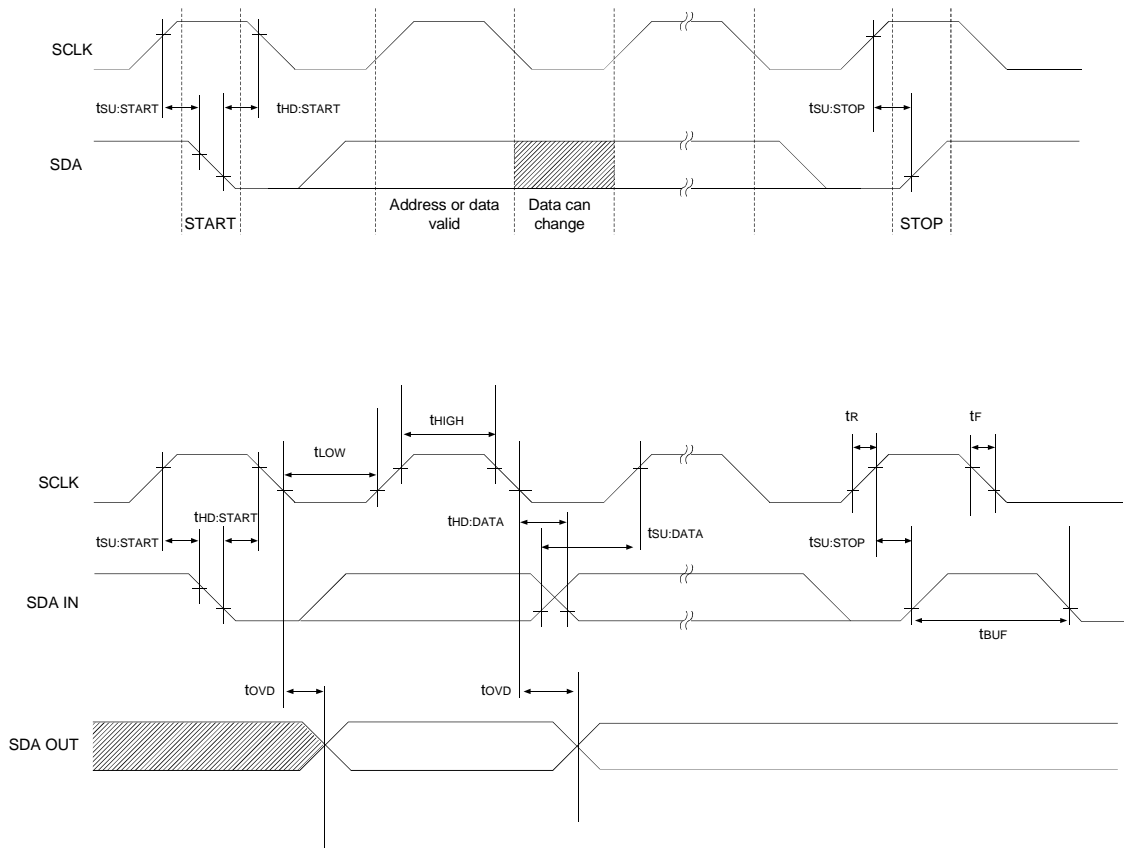

Figure 1: I<sup>2</sup>C Timing Data

## I<sup>2</sup>C INTERFACE DEFINITION

	Device Address		W	Command Code		Data		
ProgWrite	S	7'b1101xxx	0	A	8'bxxxxxx00	A	Data Byte 1 (Bits 95 - 88)	A ...
	M		L		M	L	Data Byte 2	A ...
	S		S		S	S	Data Byte 3	A ...
	B		B		B	B	Data Byte 4	A ...
							Data Byte 5	A ...
							Data Byte 6	A ...
							Data Byte 7	A ...
							Data Byte 8	A ...
							Data Byte 9	A ...
							Data Byte 10	A ...
							Data Byte 11	A ...
							Data Byte 12 (Bits 7 - 0)	A P

ID Byte:  
 Part # ID  
 5T9891 00000111

	Device Address		R	ID Byte		
ProgRead	S	7'b1101xxx	1	A	8'b00000111	A ...
					Reserved Byte	A ...
					Data Byte 1 (Bits 95 - 88)	A ...
					Data Byte 2	A ...
					Data Byte 3	A ...
					Data Byte 4	A ...
					Data Byte 5	A ...
					Data Byte 6	A ...
					Data Byte 7	A ...
					Data Byte 8	A ...
					Data Byte 9	A ...
					Data Byte 10	A ...
				Data Byte 11	A ...	
				Data Byte 12 (Bits 7 - 0)	A P	

	Device Address		W	Command Code		
ProgSave	S	7'b1101xxx	0	A	8'bxxxxxx01	A P

	Device Address		W	Command Code		
ProgRestore	S	7'b1101xxx	0	A	8'bxxxxxx10	A P

## I<sup>2</sup>C BUS DC CHARACTERISTICS

Symbol	Parameter	Conditions	Min	Typ	Max	Unit
V <sub>IH</sub>	Input HIGH Level		0.7 * V <sub>DD</sub>			V
V <sub>IL</sub>	Input LOW Level				0.3 * V <sub>DD</sub>	V
V <sub>HYS</sub>	Hysteresis of Inputs		0.05 * V <sub>DD</sub>			V
I <sub>IN</sub>	Input Leakage Current				±1.0	μA
V <sub>OL</sub>	Output LOW Voltage	I <sub>OL</sub> = 3 mA			0.4	V

## I<sup>2</sup>C BUS AC CHARACTERISTICS FOR STANDARD MODE

Symbol	Parameter	Min	Typ	Max	Unit
F <sub>SCLK</sub>	Serial Clock Frequency (SCLK)	0		100	KHz
t <sub>BUF</sub>	Bus free time between STOP and START	4.7			μs
t <sub>SU:START</sub>	Setup Time, START	4.7			μs
t <sub>HD:START</sub>	Hold Time, START	4			μs
t <sub>SU:DATA</sub>	Setup Time, data input (SDA)	250			ns
t <sub>HD:DATA</sub>	Hold Time, data input (SDA) <sup>(1)</sup>	0			μs
t <sub>OV</sub>	Output data valid from clock			3.45	μs
C <sub>B</sub>	Capacitive Load for Each Bus Line			400	pF
t <sub>r</sub>	Rise Time, data and clock (SDA, SCLK)			1000	ns
t <sub>f</sub>	Fall Time, data and clock (SDA, SCLK)			300	ns
t <sub>HIGH</sub>	HIGH Time, clock (SCLK)	4			μs
t <sub>LOW</sub>	LOW Time, clock (SCLK)	4.7			μs
t <sub>SU:STOP</sub>	Setup Time, STOP	4			μs

**NOTE:**  
1. A device must internally provide a hold time of at least 300ns for the SDA signal (referred to the V<sub>IHMIN</sub> of the SCLK signal) to bridge the undefined region of the falling edge of SCLK.

## I<sup>2</sup>C BUS AC CHARACTERISTICS FOR FAST MODE

Symbol	Parameter	Min	Typ	Max	Unit
F <sub>SCLK</sub>	Serial Clock Frequency (SCLK)	0		400	KHz
t <sub>BUF</sub>	Bus free time between STOP and START	1.3			μs
t <sub>SU:START</sub>	Setup Time, START	0.6			μs
t <sub>HD:START</sub>	Hold Time, START	0.6			μs
t <sub>SU:DATA</sub>	Setup Time, data input (SDA)	100			ns
t <sub>HD:DATA</sub>	Hold Time, data input (SDA) <sup>(1)</sup>	0			μs
t <sub>OV</sub>	Output data valid from clock			0.9	μs
C <sub>B</sub>	Capacitive Load for Each Bus Line			400	pF
t <sub>r</sub>	Rise Time, data and clock (SDA, SCLK)	20 + 0.1 * C <sub>B</sub>		300	ns
t <sub>f</sub>	Fall Time, data and clock (SDA, SCLK)	20 + 0.1 * C <sub>B</sub>		300	ns
t <sub>HIGH</sub>	HIGH Time, clock (SCLK)	0.6			μs
t <sub>LOW</sub>	LOW Time, clock (SCLK)	1.3			μs
t <sub>SU:STOP</sub>	Setup Time, STOP	0.6			μs

**NOTE:**  
1. A device must internally provide a hold time of at least 300ns for the SDA signal (referred to the V<sub>IHMIN</sub> of the SCLK signal) to bridge the undefined region of the falling edge of SCLK.

## JTAG INTERFACE

Five additional pins (TDI, TDO, TMS, TCLK and  $\overline{\text{TRST}}$ ) are provided to support the JTAG boundary scan interface. The IDT5T9891 incorporates the necessary tap controller and modified pad cells to implement the JTAG facility.

Note that IDT provides appropriate Boundary Scan Description Language program files for these devices.

The Standard JTAG interface consists of four basic elements:

- *Test Access Port (TAP)*
- *TAP controller*
- *Instruction Register (IR)*
- *Data Register Port (DR)*

The following sections provide a brief description of each element. For a complete description refer to the IEEE Standard Test Access Port Specification (IEEE Std. 1149.1-1990).

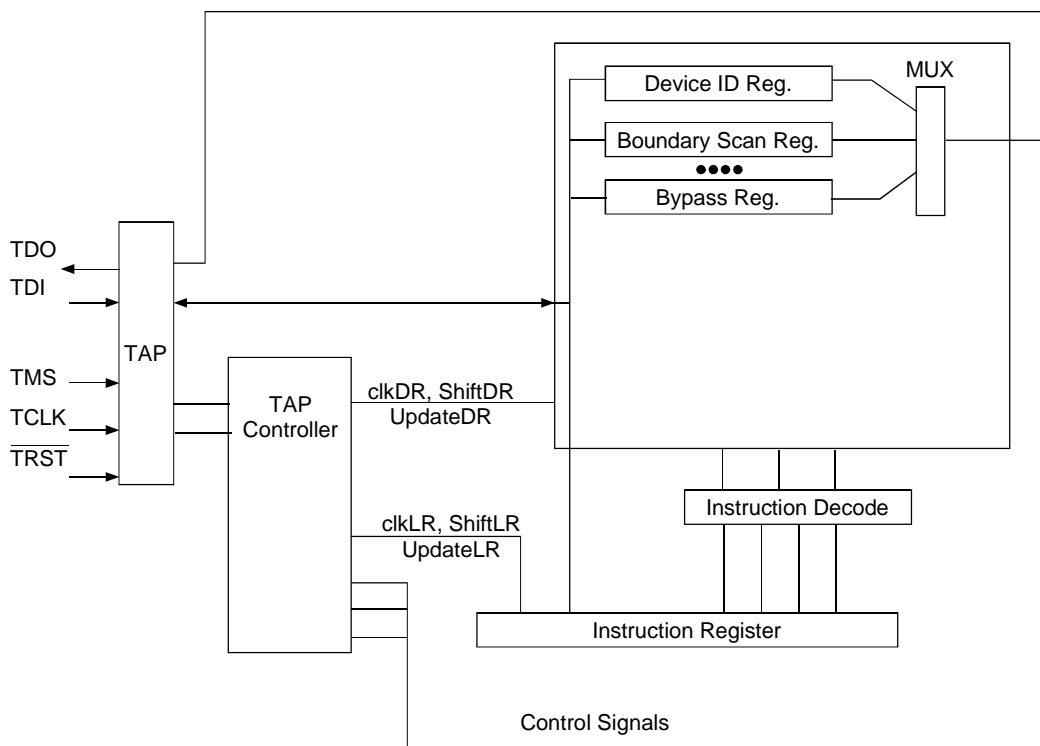

*Boundary Scan Architecture*

### TEST ACCESS PORT (TAP)

The Tap interface is a general-purpose port that provides access to the internal of the processor. It consists of four input ports (TCLK, TMS, TDI,  $\overline{\text{TRST}}$ ) and one output port (TDO).

### THE TAP CONTROLLER

The Tap controller is a synchronous finite state machine that responds to TMS and TCLK signals to generate clock and control signals to the Instruction and Data Registers for capture and update of data.

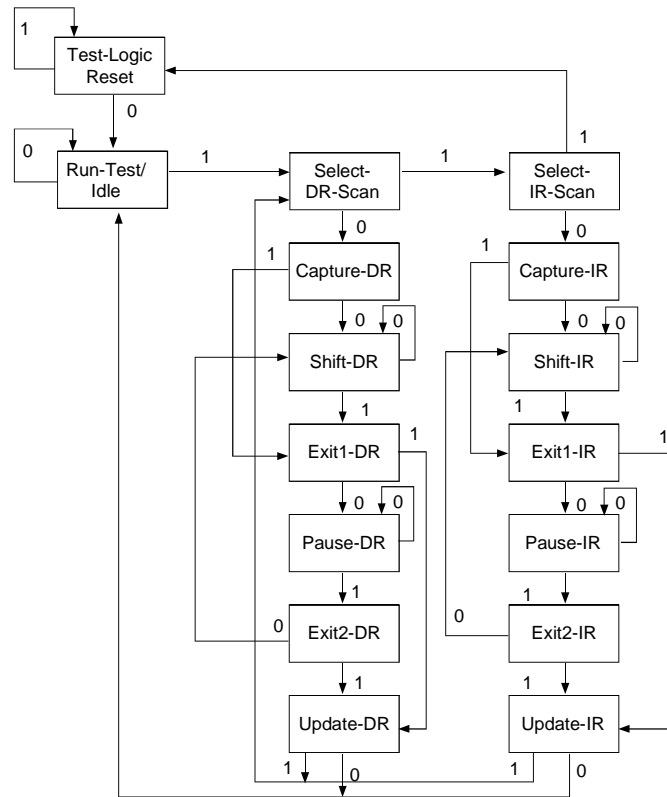

TAP Controller State Diagram

**NOTES:**

1. Five consecutive TCLK cycles with TMS = 1 will reset the TAP.
2. TAP controller must be reset before normal PLL operations can begin.

Refer to the IEEE Standard Test Access Port Specification (IEEE Std. 1149.1) for the full state diagram

All state transitions within the TAP controller occur at the rising edge of the TCLK pulse. The TMS signal level (0 or 1) determines the state progression that occurs on each TCLK rising edge. The TAP controller takes precedence over the PLL and must be reset after power up of the device. See  $\overline{TRST}$  description for more details on TAP controller reset.

**Test-Logic-Reset** All test logic is disabled in this controller state enabling the normal operation of the IC. The TAP controller state machine is designed in such a way that, no matter what the initial state of the controller is, the Test-Logic-Reset state can be entered by holding TMS at high and pulsing TCLK five times. This is the reason why the Test Reset ( $\overline{TRST}$ ) pin is optional.

**Run-Test-Idle** In this controller state, the test logic in the IC is active only if certain instructions are present. For example, if an instruction activates the self test, then it will be executed when the controller enters this state. The test logic in the IC is idles otherwise.

**Select-DR-Scan** This is a controller state where the decision to enter the Data Path or the Select-IR-Scan state is made.

**Select-IR-Scan** This is a controller state where the decision to enter the Instruction Path is made. The Controller can return to the Test-Logic-Reset state otherwise.

**Capture-IR** In this controller state, the shift register bank in the Instruction Register parallel loads a pattern of fixed values on the rising edge of TCLK. The last two significant bits are always required to be "01".

**Shift-IR** In this controller state, the instruction register gets connected between TDI and TDO, and the captured pattern gets shifted on each rising edge of TCLK. The instruction available on the TDI pin is also shifted in to the instruction register.

**Exit1-IR** This is a controller state where a decision to enter either the Pause-IR state or Update-IR state is made.

**Pause-IR** This state is provided in order to allow the shifting of instruction register to be temporarily halted.

**Exit2-DR** This is a controller state where a decision to enter either the Shift-IR state or Update-IR state is made.

**Update-IR** In this controller state, the instruction in the instruction register is latched in to the latch bank of the Instruction Register on every falling edge of TCLK. This instruction also becomes the current instruction once it is latched.

**Capture-DR** In this controller state, the data is parallel loaded in to the data registers selected by the current instruction on the rising edge of TCLK.

**Shift-DR, Exit1-DR, Pause-DR, Exit2-DR and Update-DR** These controller states are similar to the Shift-IR, Exit1-IR, Pause-IR, Exit2-IR and Update-IR states in the Instruction path.



### THE INSTRUCTION REGISTER

The Instruction register allows an instruction to be shifted in serially into the processor at the rising edge of TCLK.

The Instruction is used to select the test to be performed, or the test data register to be accessed, or both. The instruction shifted into the register is latched at the completion of the shifting process when the TAP controller is at Update-IR state.

The instruction register must contain 4 bit instruction register-based cells which can hold instruction data. These mandatory cells are located nearest the serial outputs they are the least significant bits.

### TEST DATA REGISTER

The Test Data register contains three test data registers: the Bypass, the Boundary Scan register and Device ID register.

These registers are connected in parallel between a common serial input and a common serial data output.

The following sections provide a brief description of each element. For a complete description, refer to the IEEE Standard Test Access Port Specification (IEEE Std. 1149.1-1990).

### TEST BYPASS REGISTER

The register is used to allow test data to flow through the device from TDI to TDO. It contains a single stage shift register for a minimum length in serial

path. When the bypass register is selected by an instruction, the shift register stage is set to a logic zero on the rising edge of TCLK when the TAP controller is in the Capture-DR state.

The operation of the bypass register should not have any effect on the operation of the device in response to the BYPASS instruction.

### THE BOUNDARY-SCAN REGISTER

The Boundary Scan Register allows serial data TDI be loaded in to or read out of the processor input/output ports. The Boundary Scan Register is a part of the IEEE 1149.1-1990 Standard JTAG Implementation.

### THE DEVICE IDENTIFICATION REGISTER

The Device Identification Register is a Read Only 32-bit register used to specify the manufacturer, part number and version of the processor to be determined through the TAP in response to the IDCODE instruction.

IDT JEDEC ID number is 0xB3. This translates to 0x33 when the parity is dropped in the 11-bit Manufacturer ID field.

For the IDT5T9891, the Part Number field is 0X3A9.

## JTAG DEVICE IDENTIFICATION REGISTER

31 (MSB)	28 27	12 11	1 0(LSB)
Version (4 bits) 0X0	Part number (16-bit)	Manufacturer ID (11-bit) 0X33	1

## JTAG INSTRUCTION REGISTER

The Instruction register allows instruction to be serially input into the device when the TAP controller is in the Shift-IR state. The instruction is decoded to perform the following:

- Select test data registers that may operate while the instruction is current. The other test data registers should not interfere with chip operation and the selected data register.

- Define the serial test data register path that is used to shift data between TDI and TDO during data register scanning.

The Instruction Register is a 4-bit field (i.e. IR3, IR2, IR1, IR0) to decode sixteen different possible instructions. Instructions are decoded as follows.

## JTAG INSTRUCTION REGISTER DECODING

IR (3)	IR (2)	IR (1)	IR (0)	Instruction	Function
0	0	0	0	EXTEST	Select boundary scan register
0	0	0	1	SAMPLE/PRELOAD	Select boundary scan register
0	0	1	0	IDCODE	Select chip identification data register
0	0	1	1		Reserved
0	1	0	0	PROGWRITE	Writing to the volatile programming registers
0	1	0	1	PROGREAD	Reading from the volatile programming registers
0	1	1	0	PROGSAVE	Saving the contents of the volatile programming registers to the EEPROM
0	1	1	1	PROGRESTORE	Loading the EEPROM contents into the volatile programming registers
1	0	0	0	CLAMP	JTAG
1	0	0	1	HIGHZ	JTAG
1	0	1	X	BYPASS	Select bypass register
1	1	X	X	BYPASS	Select bypass register

The following sections provide a brief description of each instruction. For a complete description refer to the IEEE Standard Test Access Port Specification (IEEE Std. 1149.1-1990).

### EXTEST

The required EXTEST instruction places the IC into an external boundary-test mode and selects the boundary-scan register to be connected between TDI and TDO. During this instruction, the boundary-scan register is accessed to drive test data off-chip through the boundary outputs, and receive test data off-chip through the boundary inputs. As such, the EXTEST instruction is the workhorse of IEEE Std 1149.1, providing for probe-less testing of solder-joint opens/shorts and of logic cluster function.

### SAMPLE/PRELOAD

The required SAMPLE/PRELOAD instruction allows the IC to remain in a normal functional mode and selects the boundary-scan register to be connected between TDI and TDO. During this instruction, the boundary-scan register can be accessed via a data scan operation, to take a sample of the functional data entering and leaving the IC.

### IDCODE

The optional IDCODE instruction allows the IC to remain in its functional mode and selects the optional device identification register to be connected between TDI and TDO. The device identification register is a 32-bit shift register containing information regarding the IC manufacturer, device type, and version code. Accessing the device identification register does not interfere with the operation of the IC. Also, access to the device identification register should be immediately available, via a TAP data-scan operation, after power-up of the IC or after the TAP has been reset using the optional TRST pin or by otherwise moving to the Test-Logic-Reset state.

### PROGWRITE

The PROGWRITE instruction is for writing the IDT5T9891 configuration data to the device's volatile programming registers. This instruction selects the programming register path for shifting data from TDI to TDO during data register scanning. The programming register path has 112 registers (14 bytes) between TDI and TDO. The 12 configuration data bytes are scanned in through TDI first, starting with Bit 0. After scanning in the last configuration bit, Bit 95, sixteen additional bits must be scanned in to place the configuration data in the proper location. The last sixteen registers in the programming path are reserved, read-only registers.

### PROGREAD

The PROGREAD instruction is for reading out the IDT5T9891 configuration data from the device's volatile programming registers. This instruction selects the programming register path for shifting data from TDI to TDO during data register scanning. The programming register path has 112 registers between TDI and TDO, and the first bit scanned out through TDO will be Bit 0 of the configuration data.

### PROGSAVE and PROGRESTORE (EEPROM OPERATION)

The PROGSAVE instruction is for copying the IDT5T9891 configuration data from the device's volatile programming registers to the EEPROM. This instruction selects the BYPASS register path for shifting data from TDI to TDO during data register scanning.

The PROGRESTORE instruction is for loading the IDT5T9891 configuration data from the EEPROM to the device's volatile programming registers. This instruction selects the BYPASS register path for shifting data from TDI to TDO during data register scanning.

During the execution of a PROGSAVE or PROGRESTORE instruction, the IDT5T9891 will not accept a new programming instruction (read, write, save, or restore). All non-programming JTAG instructions will function properly, but the user should wait until the save or restore is complete before issuing a new programming instruction. The time it takes for the save and restore instructions to complete depends on the PLL oscillator frequency,  $F_{VCO}$ . The restore time,  $T_{RESTORE}$ , and the save time,  $T_{SAVE}$ , can be calculated as follows:

$$T_{RESTORE} = 1.23 \times 10^9 / F_{VCO} \quad (\text{mS})$$

$$T_{SAVE} = 3.09 \times 10^9 / F_{VCO} + 52 \quad (\text{mS})$$

If a new programming instruction is issued before the save or restore completes, the new instruction is ignored, and the BYPASS register path remains in effect for shifting data from TDI to TDO during data register scanning.

In order for the ProgSave and ProgRestore instructions to function properly, the IDT5T9891 must not be in power-down mode ( $\overline{PD}$  must be HIGH), and the PLL must be enabled ( $\overline{PLL\_EN} = \text{LOW}$  and Bit 57 = 0).

On power-up of the IDT5T9891, an automatic restore is performed to load the EEPROM contents into the internal programming registers. The auto-restore will not function properly if the device is in power-down mode ( $\overline{PD}$  must be HIGH). The device's auto-restore feature will function regardless of the state of the  $\overline{PLL\_EN}$  pin or Bit 57. The time it takes for the device to complete the auto-restore is approximately 3ms.

### CLAMP

The optional CLAMP instruction loads the contents from the boundary-scan register onto the outputs of the IC, and selects the one-bit bypass register to be connected between TDI and TDO. During this instruction, data can be shifted through the bypass register from TDI to TDO without affecting the condition of the IC outputs.

### HIGH-IMPEDANCE

The optional High-Impedance instruction sets all outputs (including two-state as well as three-state types) of an IC to a disabled (high-impedance) state and selects the one-bit bypass register to be connected between TDI and TDO. During this instruction, data can be shifted through the bypass register from TDI to TDO without affecting the condition of the IC outputs.

### BYPASS

The required BYPASS instruction allows the IC to remain in a normal functional mode and selects the one-bit bypass register to be connected between TDI and TDO. The BYPASS instruction allows serial data to be transferred through the IC from TDI to TDO without affecting the operation of the IC.

## PROGRAMMING NOTES

Once the IDT5T9891 has been programmed either with a ProgWrite or ProgRestore instruction, the device will attempt to achieve phase lock using the new PLL configuration. If there is a valid REF and FB input clock connected to the device, and it does not achieve lock, the user should issue a ProgRead instruction to confirm that the PLL configuration data is valid.

On power-up and before the automatic ProgRestore instruction has completed, the internal programming registers will contain the value of '0' for all bits 95:0. The PLL will remain at the minimum frequency and will not achieve phase lock until after the automatic restore is completed. If the outputs are enabled by the  $\overline{nSOE}$  pins, the outputs will toggle at the minimum frequency. If the outputs are disabled by the  $\overline{nSOE}$  pins, and the OMODE pin is set high, the nQ[1:0] and QFB are stopped HIGH, while QFB is stopped LOW.

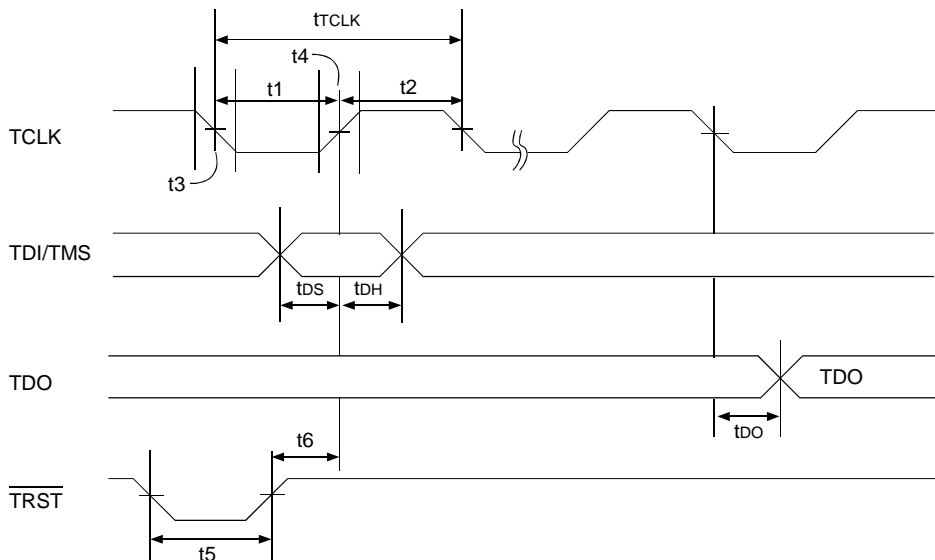

Standard JTAG Timing

**NOTE:**

- t1 = tTCLKLOW
- t2 = tTCLKHIGH
- t3 = tTCLKFALL
- t4 = tTCLKRISE
- t5 = trST (reset pulse width)
- t6 = trSR (reset recovery)

## JTAG AC ELECTRICAL CHARACTERISTICS

Symbol	Parameter	Min.	Max.	Units
tTCLK	JTAG Clock Input Period	100	—	ns
tTCLKHIGH	JTAG Clock HIGH	40	—	ns
tTCLKLOW	JTAG Clock Low	40	—	ns
tTCLKRISE	JTAG Clock Rise Time	—	5 <sup>(1)</sup>	ns
tTCLKFALL	JTAG Clock Fall Time	—	5 <sup>(1)</sup>	ns
trST	JTAG Reset	50	—	ns
trSR	JTAG Reset Recovery	50	—	ns

**NOTE:**

- 1. Guaranteed by design.

## SYSTEM INTERFACE PARAMETERS

Symbol	Parameter	Min.	Max.	Units
tDO	Data Output <sup>(1)</sup>	—	20	ns
tDOH	Data Output Hold <sup>(1)</sup>	0	—	ns
tDS	Data Input, tRISE = 3ns	10	—	ns
tDH	Data Input, tFALL = 3ns	10	—	ns

**NOTE:**

- 1. 50pF loading on external output signals.



## ORDERING INFORMATION

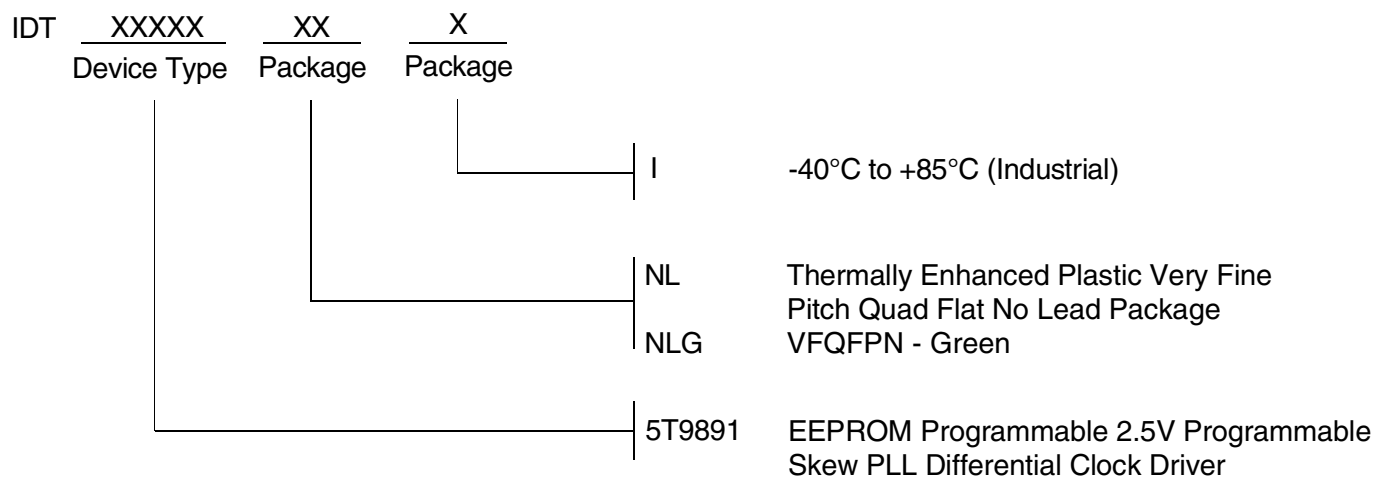

## IMPORTANT NOTICE AND DISCLAIMER

RENESAS ELECTRONICS CORPORATION AND ITS SUBSIDIARIES (“RENESAS”) PROVIDES TECHNICAL SPECIFICATIONS AND RELIABILITY DATA (INCLUDING DATASHEETS), DESIGN RESOURCES (INCLUDING REFERENCE DESIGNS), APPLICATION OR OTHER DESIGN ADVICE, WEB TOOLS, SAFETY INFORMATION, AND OTHER RESOURCES “AS IS” AND WITH ALL FAULTS, AND DISCLAIMS ALL WARRANTIES, EXPRESS OR IMPLIED, INCLUDING, WITHOUT LIMITATION, ANY IMPLIED WARRANTIES OF MERCHANTABILITY, FITNESS FOR A PARTICULAR PURPOSE, OR NON-INFRINGEMENT OF THIRD-PARTY INTELLECTUAL PROPERTY RIGHTS.

These resources are intended for developers who are designing with Renesas products. You are solely responsible for (1) selecting the appropriate products for your application, (2) designing, validating, and testing your application, and (3) ensuring your application meets applicable standards, and any other safety, security, or other requirements. These resources are subject to change without notice. Renesas grants you permission to use these resources only to develop an application that uses Renesas products. Other reproduction or use of these resources is strictly prohibited. No license is granted to any other Renesas intellectual property or to any third-party intellectual property. Renesas disclaims responsibility for, and you will fully indemnify Renesas and its representatives against, any claims, damages, costs, losses, or liabilities arising from your use of these resources. Renesas' products are provided only subject to Renesas' Terms and Conditions of Sale or other applicable terms agreed to in writing. No use of any Renesas resources expands or otherwise alters any applicable warranties or warranty disclaimers for these products.

(Disclaimer Rev.1.01 Jan 2024)

### Corporate Headquarters

TOYOSU FORESIA, 3-2-24 Toyosu,  
Koto-ku, Tokyo 135-0061, Japan  
[www.renesas.com](http://www.renesas.com)

### Trademarks

Renesas and the Renesas logo are trademarks of Renesas Electronics Corporation. All trademarks and registered trademarks are the property of their respective owners.

### Contact Information

For further information on a product, technology, the most up-to-date version of a document, or your nearest sales office, please visit [www.renesas.com/contact-us/](http://www.renesas.com/contact-us/).