

## Low Skew Output Buffer

### General Description

The ICS9112-26 is a high performance, low skew, low jitter clock driver. It is designed to distribute high speed clocks in PC systems operating at speeds from 0 to 133 MHz.

The ICS9112-26 comes in an eight pin 150 mil SOIC package. It has four output clocks.

### Features

- Frequency range 0 - 133 MHz (3.3V)
- Less than 200 ps Jitter between outputs
- Skew controlled outputs
- Skew less than 250 ps between outputs
- Available in 8 pin 150 mil SOIC & 173 mil TSSOP packages.
- 3.3V  $\pm$ 10% operation

### Block Diagram

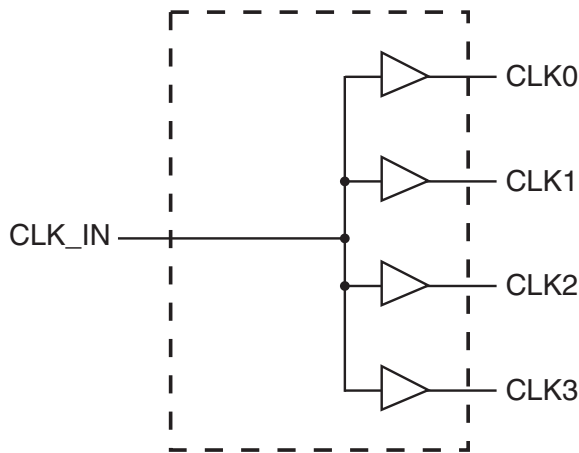

### Pin Configuration

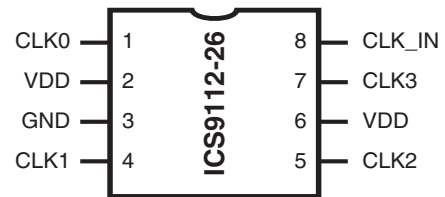

### 8 pin SOIC & TSSOP

### Pin Descriptions

PIN NUMBER	PIN NAME	TYPE	DESCRIPTION
1	CLK0 <sup>1</sup>	OUT	Buffered clock output
2,6	VDD	PWR	Power Supply (3.3V)
3	GND	PWR	Ground
4	CLK1 <sup>1</sup>	OUT	Buffered clock output
5	CLK2 <sup>1</sup>	OUT	Buffered clock output
7	CLK3 <sup>1</sup>	OUT	Buffered clock output
8	CLK_IN	IN	Input reference frequency.

Notes:

1. Weak pull-down on all outputs

## Absolute Maximum Ratings

Supply Voltage	7.0 V
Logic Inputs	GND -0.5 V to $V_{DD} + 0.5$ V
Ambient Operating Temperature	0°C to +70°C
Storage Temperature	-65°C to +150°C

Stresses above those listed under *Absolute Maximum Ratings* may cause permanent damage to the device. These ratings are stress specifications only and functional operation of the device at these or any other conditions above those listed in the operational sections of the specifications is not implied. Exposure to absolute maximum rating conditions for extended periods may affect product reliability.

## Electrical Characteristics at 3.3V

$T_A = 0 - 70$ °C; Supply Voltage  $V_{DD} = 3.3$  V +/-5% (unless otherwise stated)

PARAMETER	SYMBOL	CONDITIONS	MIN	TYP	MAX	UNITS
High-level Output Voltage	$V_{OH}$	$V_{DD} = \text{min to max}, I_{OH} = -1$ mA	$V_{DD} - 0.2$	3.3		V
		$V_{DD} = 3$ V, $I_{OH} = -24$ mA	2	2.9		V
		$V_{DD} = 3$ V, $I_{OH} = 12$ mA	2.4	3.1		V
Low-level Output Voltage	$V_{OL}$	$V_{DD} = \text{min to max}, I_{OH} = 1$ mA		0.0055	0.2	V
		$V_{DD} = 3$ V, $I_{OH} = 24$ mA		0.28	0.8	V
		$V_{DD} = 3$ V, $I_{OH} = 12$ mA		0.14	0.55	V
High-level Input Current	$I_{OH}$	$V_{DD} = 3$ V, $V_O = 1$ V		-61	-50	
		$V_{DD} = 3.3$ V, $V_O = 1.65$ V		-77		
Low-level Input Current	$I_{OL}$	$V_{DD} = 3$ V, $V_O = 2$ V	60	103		
		$V_{DD} = 3.3$ V, $V_O = 1.65$ V		111		
Input Current	$I_I$	$V = V_O$ or $V_{DD}$	-5		5	μA
Input Capacitance <sup>1</sup>	$C_I$	$V_{DD} = 3.3$ V, $V_I = 0$ V or 3.3 V		3		pF
Output Capacitance <sup>1</sup>	CO	$V_{DD} = 3.3$ V, $V_I = 0$ V or 3.3 V		3.2		pF
Supply current	$I_{DD}$	REF = 0 MHz		22	50	μA
		Unloaded outputs at 66.67 MHz		25	40	mA

1. Guaranteed by design, not 100% tested in production.

## Switching Characteristics at 3.3V

$T_A = 0 - 70$ °C; Supply Voltage  $V_{DD} = 3.3$  V +/-5% (unless otherwise stated)

PARAMETER	SYMBOL	CONDITIONS	MIN	TYP	MAX	UNITS
Low-to-high Propagation Delay <sup>1</sup>	$t_{PLH}$	$V_O = V_{DD}/2$	4	5.6	7	ns
High-to-low Propagation Delay <sup>1</sup>	$t_{PHL}$	$V_O = V_{DD}/2$	4	5.2	7	ns
Output Skew Window <sup>1</sup>	$T_{sk}(O)$	$V_O = V_{DD}/2$		50	100	ps
Process Skew <sup>1</sup>	$T_{sk}(PR)$	$V_O = V_{DD}/2$			0.5	ps
CLKIN High Time <sup>1</sup>	$T_{high}$	66 MHz	6			ns
		133 MHz	3			
CLKIN Low Time <sup>1</sup>	$T_{low}$	66 MHz	6			ns
		133 MHz	3			
Output Rise Slew Rate <sup>1</sup>	$T_r$	0.3 to 0.6 $V_{DD}$	2	3.6	5	V/ns
Output Rise Slew Rate <sup>1</sup>	$T_f$	0.3 to 0.6 $V_{DD}$	2	3.2	5	V/ns

1. Guaranteed by design, not 100% tested in production.

Notes:

- Guaranteed by design and characterization. Not subject to 100% test.
- CLK\_IN input has a threshold voltage of 1.4V
- All parameters expected with loaded outputs

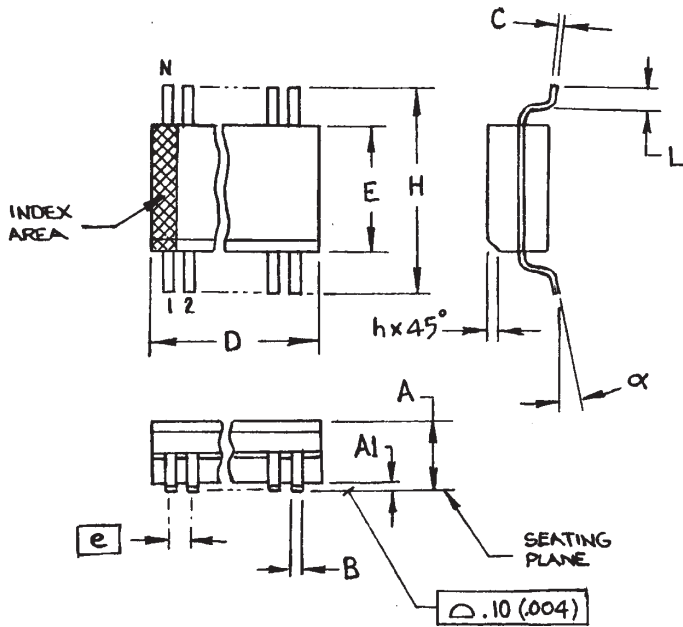

SYMBOL	In Millimeters COMMON DIMENSIONS		In Inches COMMON DIMENSIONS	
	MIN	MAX	MIN	MAX
A	1.35	1.75	.0532	.0688
A1	0.10	0.25	.0040	.0098
B	0.33	0.51	.013	.020
C	0.19	0.25	.0075	.0098
D	SEE VARIATIONS		SEE VARIATIONS	
E	3.80	4.0	.1497	.1574
e	1.27 BASIC		0.050 BASIC	
H	5.80	6.20	.2284	.2440
h	0.25	0.50	.010	.020
L	0.40	1.27	.016	.050
N	SEE VARIATIONS		SEE VARIATIONS	
$\alpha$	0°	8°	0°	8°

VARIATIONS

N	D mm.		D (inch)	
	MIN	MAX	MIN	MAX
8	4.80	5.00	.1890	.1968

150 mil (Narrow Body) SOIC

Ordering Information

9112yM-26LFT

Example:

XXXX y M - PPP LFT

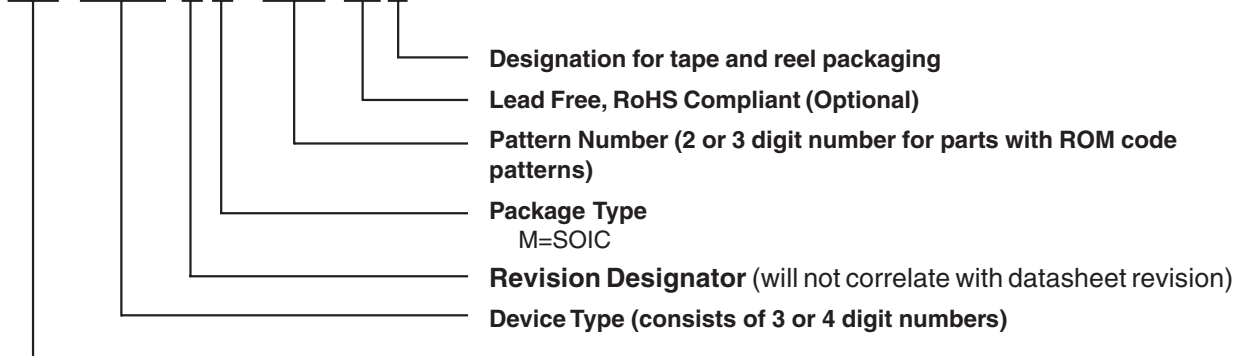

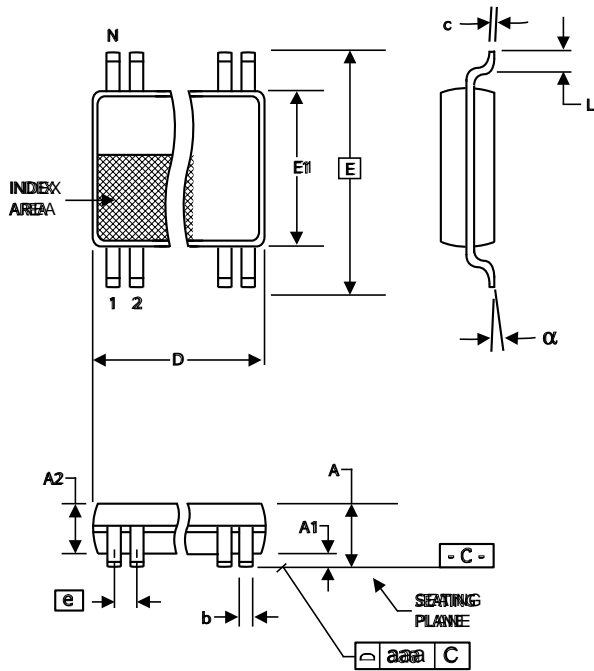

4.40 mm. Body, 0.65 mm. pitch TSSOP  
(173 mil) (0.0256 mil)

SYMBOL	In Millimeters COMMON DIMENSIONS		In Inches COMMON DIMENSIONS	
	MIN	MAX	MIN	MAX
A	-	1.20	-	.047
A1	0.05	0.15	.002	.006
A2	0.80	1.05	.032	.041
b	0.19	0.30	.007	.012
c	0.09	0.20	.0035	.008
D	SEE VARIATIONS		SEE VARIATIONS	
E	6.40 BASIC		0.252 BASIC	
E1	4.30	4.50	.169	.177
e	0.65 BASIC		0.0256 BASIC	
L	0.45	0.75	.018	.030
N	SEE VARIATIONS		SEE VARIATIONS	
alpha	0°	8°	0°	8°
aaa	-	0.10	-	.004

VARIATIONS

N	D mm.		D (inch)	
	MIN	MAX	MIN	MAX
8	2.90	3.10	.114	.122

MO-153 JEDEC 7/6/00 Rev B  
Doc.# 10-0038

## Ordering Information

9112yG-26LFT

Example:

XXXX y G - PPP LFT

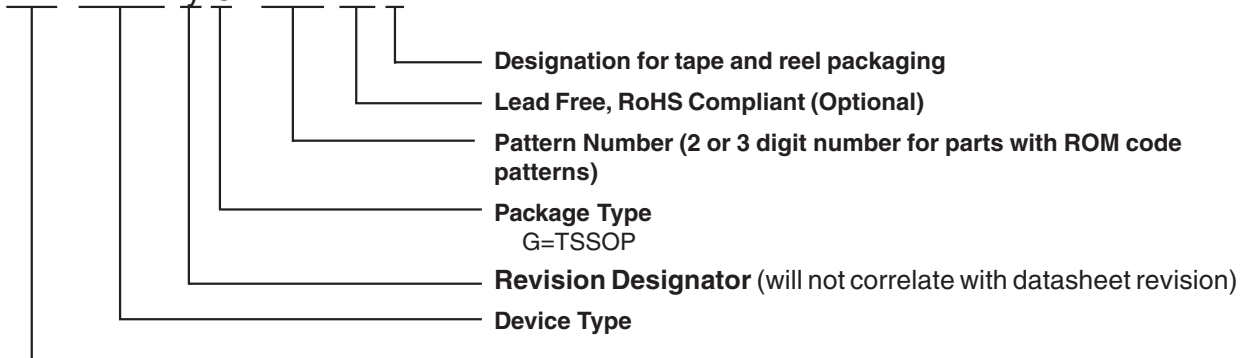

**Revision History**

<b>Rev.</b>	<b>Issue Date</b>	<b>Description</b>	<b>Page #</b>
C	04/17/07	Added LF to Ordering Information.	-
D	05/14/07	Updated Ordering Information.	3-4

## IMPORTANT NOTICE AND DISCLAIMER

RENESAS ELECTRONICS CORPORATION AND ITS SUBSIDIARIES (“RENESAS”) PROVIDES TECHNICAL SPECIFICATIONS AND RELIABILITY DATA (INCLUDING DATASHEETS), DESIGN RESOURCES (INCLUDING REFERENCE DESIGNS), APPLICATION OR OTHER DESIGN ADVICE, WEB TOOLS, SAFETY INFORMATION, AND OTHER RESOURCES “AS IS” AND WITH ALL FAULTS, AND DISCLAIMS ALL WARRANTIES, EXPRESS OR IMPLIED, INCLUDING, WITHOUT LIMITATION, ANY IMPLIED WARRANTIES OF MERCHANTABILITY, FITNESS FOR A PARTICULAR PURPOSE, OR NON-INFRINGEMENT OF THIRD-PARTY INTELLECTUAL PROPERTY RIGHTS.

These resources are intended for developers who are designing with Renesas products. You are solely responsible for (1) selecting the appropriate products for your application, (2) designing, validating, and testing your application, and (3) ensuring your application meets applicable standards, and any other safety, security, or other requirements. These resources are subject to change without notice. Renesas grants you permission to use these resources only to develop an application that uses Renesas products. Other reproduction or use of these resources is strictly prohibited. No license is granted to any other Renesas intellectual property or to any third-party intellectual property. Renesas disclaims responsibility for, and you will fully indemnify Renesas and its representatives against, any claims, damages, costs, losses, or liabilities arising from your use of these resources. Renesas' products are provided only subject to Renesas' Terms and Conditions of Sale or other applicable terms agreed to in writing. No use of any Renesas resources expands or otherwise alters any applicable warranties or warranty disclaimers for these products.

(Disclaimer Rev.1.01)

### Corporate Headquarters

TOYOSU FORESIA, 3-2-24 Toyosu,  
Koto-ku, Tokyo 135-0061, Japan  
[www.renesas.com](http://www.renesas.com)

### Trademarks

Renesas and the Renesas logo are trademarks of Renesas Electronics Corporation. All trademarks and registered trademarks are the property of their respective owners.

### Contact Information

For further information on a product, technology, the most up-to-date version of a document, or your nearest sales office, please visit [www.renesas.com/contact-us/](http://www.renesas.com/contact-us/).