



## Low EMI, Spread Modulating, Clock Generator

### Features:

- ICS91720 is a Spread Spectrum Clock targeted for Mobile PC and LCD panel applications that generates an EMI-optimized clock signal (EMI peak reduction of 7-14 dB on 3rd-19th harmonics) through use of Spread Spectrum techniques.
- ICS91720 focuses on the lower input frequency range of 14.318 to 80.00 MHz with a spread modulation of 20kHz to 40kHz.

### Specifications:

- Supply Voltages:  $V_{DD} = 3.3V \pm 0.3V$
- Frequency range:  $14.318 \text{ MHz} \leq F_{in} \leq 80 \text{ MHz}$
- Cyc to Cyc jitter: <150ps
- Output duty cycle 45-55%
- Guarantees +85°C operational condition.
- 8-pin SOIC/TSSOP
- Reference input

### Pin Configuration

CLKIN	1	8	PD#*
VDD	2	7	SCLK
GND	3	6	SDATA
**CLKOUT/FS_IN0	4	5	REF_OUT/FS_IN1*

### 8 Pin SOIC/TSSOP

\* Internal Pull-Up Resistor

\*\* Internal Pull-Down Resistor

### Functionality

FSIN_1	FSIN_0	MHz	Spread % default
0	0	14.318 MHz in --> 27MHz out	-0.8 down spread
0	1	14.318MHz -->14.318MHz out	-1.00 down spread
1	0	27.00MHz in --> 27.00MHz out	-1.25 down spread
1	1	48.00MHz in -->48.00 MHz out	-0.8 down spread

### Block Diagram

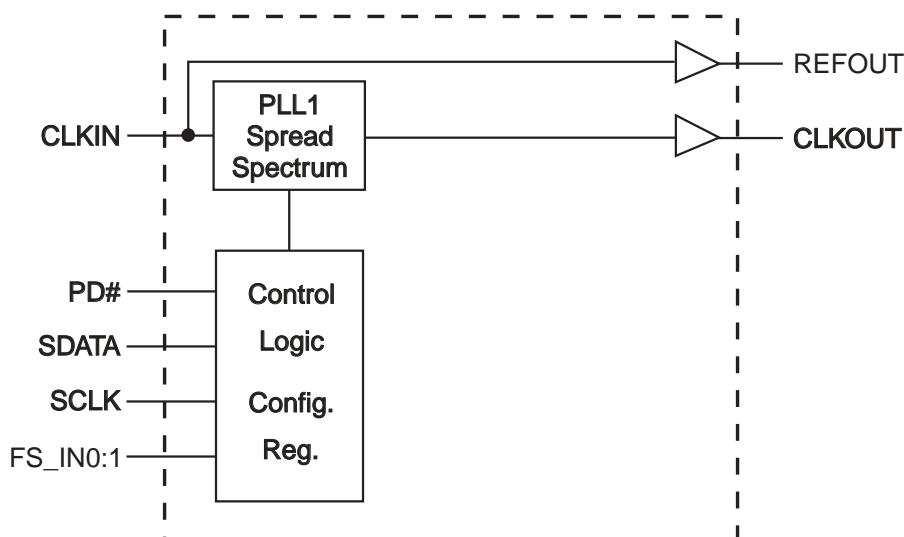

## Pin Description

PIN #	PIN NAME	PIN TYPE	DESCRIPTION
1	CLKIN	PWR	Input for reference clock.
2	VDD	IN	Power supply, nominal 3.3V
3	GND	OUT	Ground pin.
4	**CLKOUT/FS_IN0	I/O	Modulated clock output.
			Frequency select latch input. Refer to the functionality table.
5	REF_OUT/FS_IN1*	I/O	Un-modulated 3.3V reference clock output.
			Frequency select latch input. Refer to the functionality table.
6	SDATA	PWR	Data pin for I2C circuitry 5V tolerant
7	SCLK	PWR	Clock pin of I2C circuitry 5V tolerant
8	PD#*	PWR	Asynchronous active low input pin used to power down the device into a low power state. The internal clocks are disabled and the VCO and the crystal are stopped. The latency of the power down will not be greater than 1.8ms.

\* Internal Pull-Up Resistor \*\* Internal Pull-Down Resistor

**Table 1: Frequency Configuration Table  
(See I2C Byte 0)**

	FS4	FS3	FS2	FS1	FS0	Sprd Type	Sprd %
14in/27out	0	0	0	0	0	DOWN SPREAD (-)	0.60
	0	0	0	0	1		0.80
	0	0	0	1	0		1.00
	0	0	0	1	1		1.25
	0	0	1	0	0		1.50
	0	0	1	0	1		2.00
	0	0	1	1	0	CENTER SPD (+/-)	0.50
	0	0	1	1	1	1.00	
14in/14out 27in/27out	0	1	0	0	0	DOWN SPREAD (-)	0.60
	0	1	0	0	1		1.00
	0	1	0	1	0		-0.80
	0	1	0	1	1	CNTR SPD	+/-0.3
	0	1	1	0	0	DOWN SPREAD (-)	1.50
	0	1	1	0	1		1.75
	0	1	1	1	0		2.00
	0	1	1	1	1		2.50
	1	0	0	0	0		3.00
	1	0	0	0	1		-1.25
	1	0	0	1	0	CENTER SPREAD (+/-)	0.40
	1	0	0	1	1		0.50
	1	0	1	0	0		0.70
	1	0	1	0	1		1.00
	1	0	1	1	0		1.20
	1	0	1	1	1		1.50
48in/48out 66in/66out	1	1	0	0	0	DOWN SPREAD (-)	0.60
	1	1	0	0	1		0.80
	1	1	0	1	0		1.00
	1	1	0	1	1		1.25
	1	1	1	0	0		1.50
	1	1	1	0	1		2.00
	1	1	1	1	0	CENTER SPD (+/-)	0.50
	1	1	1	1	1	1.00	

Above is the hard coded 5 bit (32 entry) ROM table.

FS2:0 are ONLY accessible through I2C software programming bits (byte0 bits5:7). FS3 and FS4 can also be decoded from FS\_IN0:1 latched input hardware pins.

FS\_IN0 → FS3 and FS\_IN1 → FS4. Upon power-up the default is to use hardware selections of FS\_IN0:1 latched values.

FS2 = 0, FS1 = 0, FS0 = 1 upon power-up (refer to the functionality table on page 1).

To access non-default spread entries in the ROM, byte0 programming should be used. In order to change the power up default of FS\_IN1:0 = 10 (-1.25% down spread) to any other spread % entry, first change byte0bit 0 to software selection by switching this bit to a '1' and then program the desired percentage by changing byte0 bits 7:3.

## General I<sup>2</sup>C serial interface information

### How to Write:

- Controller (host) sends a start bit.
- Controller (host) sends the write address D4<sub>(H)</sub>
- ICS clock will **acknowledge**
- Controller (host) sends the beginning byte location = N
- ICS clock will **acknowledge**
- Controller (host) sends the data byte count = X
- ICS clock will **acknowledge**
- Controller (host) starts sending **Byte N through Byte N + X - 1**  
(see Note 2)
- ICS clock will **acknowledge** each byte **one at a time**
- Controller (host) sends a Stop bit

### How to Read:

- Controller (host) will send start bit.
- Controller (host) sends the write address D4<sub>(H)</sub>
- ICS clock will **acknowledge**
- Controller (host) sends the beginning byte location = N
- ICS clock will **acknowledge**
- Controller (host) will send a separate start bit.
- Controller (host) sends the read address D5<sub>(H)</sub>
- ICS clock will **acknowledge**
- ICS clock will send the data byte count = X
- ICS clock sends **Byte N + X - 1**
- ICS clock sends **Byte 0 through byte X (if X<sub>(H)</sub> was written to byte 8).**
- Controller (host) will need to acknowledge each byte
- Controller (host) will send a not acknowledge bit
- Controller (host) will send a stop bit

Index Block Write Operation		
Controller (Host)		ICS (Slave/Receiver)
T	starT bit	
Slave Address D4 <sub>(H)</sub>		
WR	WRite	
		ACK
Beginning Byte = N		
		ACK
Data Byte Count = X		
		ACK
Beginning Byte N	X Byte	
○		ACK
○		○
○		○
○		○
Byte N + X - 1		
		ACK
P	stoP bit	

Index Block Read Operation		
Controller (Host)		ICS (Slave/Receiver)
T	starT bit	
Slave Address D4 <sub>(H)</sub>		
WR	WRite	
		ACK
Beginning Byte = N		
		ACK
RT	Repeat starT	
Slave Address D5 <sub>(H)</sub>		
RD	ReaD	
		ACK
		Data Byte Count = X
ACK		
ACK		Beginning Byte N
		○
		○
		○
		○
		○
		Byte N + X - 1
N	Not acknowledge	
P	stoP bit	

Byte 0	Affected Pin			Type	Bit Control		PWD
	Pin #	Name	Control Function		0	1	
Bit 7	-	FS0	Spread/FS0	RW	Spread percentage See Table 1 These are I2C bits only		1
Bit 6	-	FS1	Spread/FS1	RW			0
Bit 5		FS2	Spread/FS2	RW			0
Bit 4		FS3	Spread/FS3	RW			0
Bit 3		FS4	FS4	RW			0
Bit 2		PD# Tri_Sate	PD# Tri_Sate	RW	Hi-Z	LOW	1
Bit 1		Spread Enable	Spread Enable	RW	OFF	ON	1
Bit 0		HW/SW Control	Spread Spectrum Control FS 3:4 Hard/Software Select	RW	HW	SW	0

Byte 1	Affected Pin			Type	Bit Control		PWD
	Pin #	Name	Control Function		0	1	
Bit 7		REF_OUT	REF_OUT_Enable	RW	Disable	Enable	1
Bit 6	-	REF_OUT	Slew Rate REF-OUT	RW	Nominal	Fast	1
Bit 5		FS-IN_1	FS-IN_1 Readback	R	-	-	X
Bit 4		FS-IN_0	FS-IN_0 Readback	R	-	-	X
Bit 3		CLK_OUT	Slew Rate CLK-OUT	RW	Nominal	Fast	1
Bit 2		CLK_OUT	CLK_OUT_Enable	RW	Disable	Enable	1
Bit 1		(Reserved)	(Reserved)	R	-	-	1
Bit 0		(Reserved)	(Reserved)	R	-	-	1

Byte 2	Affected Pin			Type	Bit Control		PWD
	Pin #	Name	Control Function		0	1	
Bit 7	x	-	(Reserved)	-	-	-	1
Bit 6	x	(Reserved)	(Reserved)	RW	-	-	1
Bit 5	x	(Reserved)	(Reserved)	RW	-	-	1
Bit 4	x	(Reserved)	(Reserved)	RW	-	-	1
Bit 3	x	(Reserved)	(Reserved)	RW	-	-	1
Bit 2	x	(Reserved)	(Reserved)	RW	-	-	1
Bit 1	x	(Reserved)	(Reserved)	RW	-	-	1
Bit 0	x	(Reserved)	(Reserved)	RW	-	-	1

Byte 3	Affected Pin			Type	Bit Control		PWD
	Pin #	Name	Control Function		0	1	
Bit 7	X	(Reserved)	(Reserved)	RW	-	-	1
Bit 6	X	(Reserved)	(Reserved)	RW	-	-	1
Bit 5	X	(Reserved)	(Reserved)	RW	-	-	1
Bit 4	X	(Reserved)	(Reserved)	RW	-	-	1
Bit 3	x	(Reserved)	(Reserved)	RW	-	-	1
Bit 2	X	(Reserved)	(Reserved)	RW	-	-	1
Bit 1	X	(Reserved)	(Reserved)	RW	-	-	1
Bit 0	X	(Reserved)	(Reserved)	RW	-	-	1

Byte 4	Affected Pin			Type	Bit Control		PWD
	Pin #	Name	Control Function		0	1	
Bit 7	X	(Reserved)	(Reserved)	RW	-	-	1
Bit 6	X	(Reserved)	(Reserved)	RW	-	-	1
Bit 5	X	(Reserved)	(Reserved)	RW	-	-	1
Bit 4	X	(Reserved)	(Reserved)	RW	-	-	1
Bit 3	X	(Reserved)	(Reserved)	RW	-	-	1
Bit 2	X	(Reserved)	(Reserved)	RW	-	-	1
Bit 1	X	(Reserved)	(Reserved)	RW	-	-	1
Bit 0	X	(Reserved)	(Reserved)	RW	-	-	1

Byte 5	Affected Pin			Type	Bit Control		PWD
	Pin #	Name	Control Function		0	1	
Bit 7	X	(Reserved)	(Reserved)	-	-	-	1
Bit 6	X	(Reserved)	(Reserved)	-	-	-	1
Bit 5	X	(Reserved)	(Reserved)	-	-	-	1
Bit 4	X	(Reserved)	(Reserved)	-	-	-	1
Bit 3	X	(Reserved)	(Reserved)	RW	-	-	1
Bit 2	X	(Reserved)	(Reserved)	RW	-	-	1
Bit 1	X	(Reserved)	(Reserved)	RW	-	-	1
Bit 0	X	(Reserved)	(Reserved)	RW	-	-	1

Byte 6	Affected Pin			Type	Bit Control		PWD
	Pin #	Name	Control Function		0	1	
Bit 7	X	Revision ID Bit 3	(Reserved)	R	-	-	1
Bit 6	X	Revision ID Bit 2	(Reserved)	R	-	-	1
Bit 5	X	Revision ID Bit 1	(Reserved)	R	-	-	1
Bit 4	X	Revision ID Bit 0	(Reserved)	R	-	-	1
Bit 3	X	Vendor ID Bit 3	(Reserved)	R	-	-	1
Bit 2	X	Vendor ID Bit 2	(Reserved)	R	-	-	1
Bit 1	X	Vendor ID Bit 1	(Reserved)	R	-	-	1
Bit 0	X	Vendor ID Bit 0	(Reserved)	R	-	-	1

## Absolute Maximum Ratings

Supply Voltage.....	3.3 V
Voltage on any pin with respect to GND ...	-0.5 to +7.0 V
Storage Temperature.....	-55°C to +125°C
Operating Temperature.....	0°C to +85°C
Ambient Operating Temperature under Bias.	-55 to +125 °C
Power Dissipation.....	0.5 W

Stresses above those listed under *Absolute Maximum Ratings* may cause permanent damage to the device. These ratings are stress specifications only and functional operation of the device at these or any other conditions above those listed in the operational sections of the specifications is not implied. Exposure to absolute maximum rating conditions for extended periods may affect product reliability.

## Electrical Characteristics - Input/Supply/Common Output Parameters

$T_A = 0 - 85^\circ\text{C}$ ; Supply Voltage  $V_{DD} = 3.3\text{ V} \pm 5\%$

PARAMETER	SYMBOL	CONDITIONS	MIN	TYP	MAX	UNITS
Input High Voltage	$V_{IH}$		2		$V_{DD} + 0.3$	V
Input Low Voltage	$V_{IL}$		$V_{SS} - 0.3$		0.8	V
Input High Current	$I_{IH}$	$V_{IN} = V_{DD}$	-5		5	mA
Input Low Current	$I_{IL1}$	$V_{IN} = 0\text{ V}$ ; Inputs with no pull-up resistors	-5			mA
Powerdown Current	$I_{DD3,3PD}$			3	5	mA
Input Frequency	$F_i$	$V_{DD} = 3.3\text{ V}$	14.318	-	80	MHz
Pin Inductance	$L_{pin}$				7	nH
Input Capacitance <sup>1</sup>	$C_{IN}$	Logic Inputs			5	pF
	$C_{OUT}$	Output pin capacitance			6	pF
	$C_{INX}$	X1 & X2 pins	27	36	45	pF
Transition time <sup>1</sup>	$T_{trans}$	To 1st crossing of target frequency			3	ms
Settling time <sup>1</sup>	$T_s$	From 1st crossing to 1% target frequency			3	ms
Clk Stabilization <sup>1</sup>	$T_{STAB}$	From $V_{DD} = 3.3\text{ V}$ to 1% target frequency			3	ms
Delay <sup>1</sup>	$t_{PZH}, t_{PZL}$	Output enable delay (all outputs)	1		10	ns

<sup>1</sup>Guaranteed by design, not 100% tested in production.



### Electrical Characteristics - CLKOUT

$T_A = 0 - 85^\circ\text{C}$ ;  $V_{DD} = 3.3\text{V} \pm 5\%$ ;  $C_L = 10\text{-}20\text{ pF}$  (unless otherwise specified)

PARAMETER	SYMBOL	CONDITIONS	MIN	TYP	MAX	UNITS
Output High Voltage	$V_{OH3}$	$I_{OH} = -1\text{ mA}$	2.4			V
Output Low Voltage	$V_{OL3}$	$I_{OL} = 1\text{ mA}$			0.4	V
Rise Time	$t_{r3}$	$V_{OL} = 0.41\text{V}$ , $V_{OH} = 0.86\text{V}$	0.5	0.6	1	ns
Fall Time	$t_{f3}$	$V_{OH} = 0.86\text{V}$ , $V_{OL} = 0.41\text{V}$	0.5	0.6	1	ns
Duty Cycle	$d_{t3}$	measurement from differential waveform - 0.35V to +035V	45	50	55	%
Jitter, Cycle to cycle	$t_{j\text{cyc-cyc}}^1$	$V_T = 50\%$		50	150	ps

<sup>1</sup>Guaranteed by design, not 100% tested in production.

### Electrical Characteristics - REF

$T_A = 0 - 85^\circ\text{C}$ ;  $V_{DD} = 3.3\text{V} \pm 5\%$ ;  $C_L = 10\text{-}20\text{ pF}$  (unless otherwise specified)

PARAMETER	SYMBOL	CONDITIONS	MIN	TYP	MAX	UNITS
Output Frequency	$F_{O1}$					MHz
Output Impedance	$R_{DSP1}^1$	$V_O = V_{DD} * (0.5)$	20	48	60	$\Omega$
Output High Voltage	$V_{OH}^1$	$I_{OH} = -1\text{ mA}$	2.4			V
Output Low Voltage	$V_{OL}^1$	$I_{OL} = 1\text{ mA}$			0.4	V
Output High Current	$I_{OH}^1$	$V_{OH@MIN} = 1.0\text{ V}$ , $V_{OH@MAX} = 3.135\text{ V}$	-29		-23	mA
Output Low Current	$I_{OL}^1$	$V_{OL@MIN} = 1.95\text{ V}$ , $V_{OL@MAX} = 0.4\text{ V}$	29		27	mA
Rise Time	$t_{r1}^1$	$V_{OL} = 0.4\text{ V}$ , $V_{OH} = 2.4\text{ V}$	1	1.2	2	ns
Fall Time	$t_{f1}^1$	$V_{OH} = 2.4\text{ V}$ , $V_{OL} = 0.4\text{ V}$	1	1.2	2	ns
Duty Cycle	$d_{t1}^1$	$V_T = 1.5\text{ V}$	45	51	55	%
Jitter	$t_{j\text{cyc-cyc}}^1$	$V_T = 1.5\text{ V}$		105	300	ps

<sup>1</sup>Guaranteed by design, not 100% tested in production.

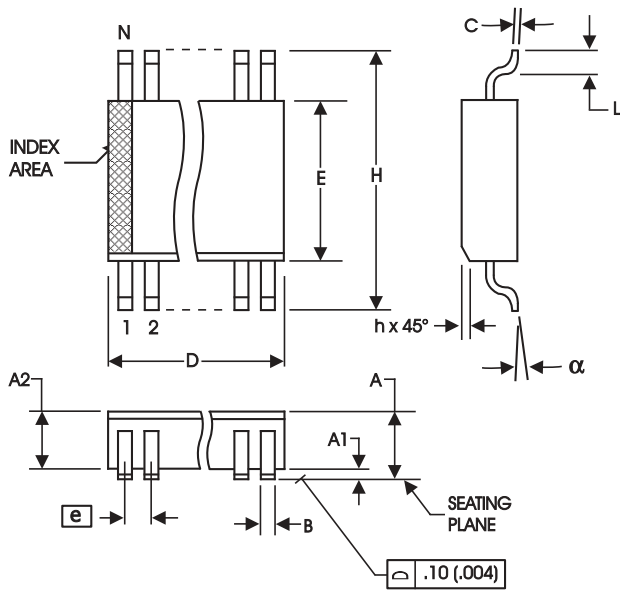

8-pin SOIC

150 mil (Narrow Body) SOIC

SYMBOL	In Millimeters		In Inches	
	COMMON DIMENSIONS		COMMON DIMENSIONS	
	MIN	MAX	MIN	MAX
A	1.35	1.75	.0532	.0688
A1	0.10	0.25	.0040	.0098
B	0.33	0.51	.013	.020
C	0.19	0.25	.0075	.0098
D	SEE VARIATIONS		SEE VARIATIONS	
E	3.80	4.00	.1497	.1574
e	1.27 BASIC		0.050 BASIC	
H	5.80	6.20	.2284	.2440
h	0.25	0.50	.010	.020
L	0.40	1.27	.016	.050
N	SEE VARIATIONS		SEE VARIATIONS	
alpha	0°	8°	0°	8°

VARIATIONS

N	D mm.		D (inch)	
	MIN	MAX	MIN	MAX
8	4.80	5.00	.1890	.1968

Reference Doc.: JEDEC Publication 95, MS-012

10-0030

Ordering Information

ICS91720yMLF-T

Example:

ICS XXXX y M LF-T

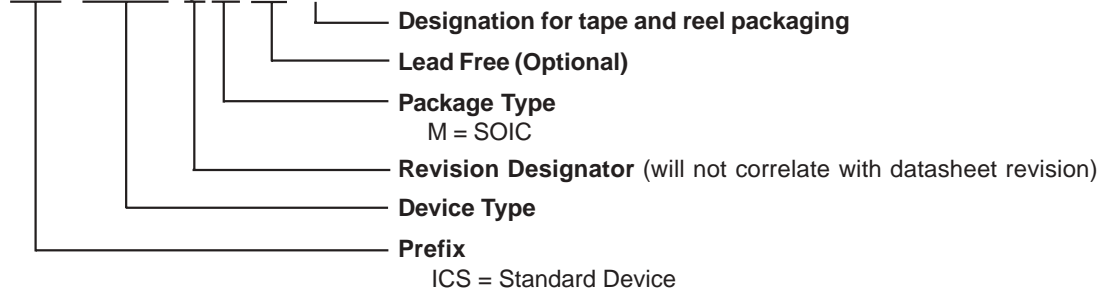

**4.40 mm. Body, 0.65 mm. Pitch TSSOP  
(173 mil) (25.6 mil)**

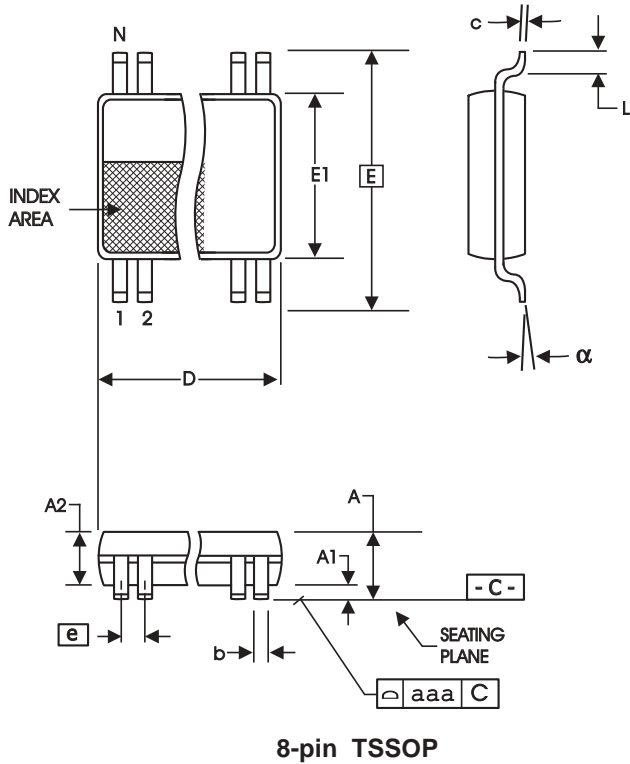

**8-pin TSSOP**

SYMBOL	In Millimeters COMMON DIMENSIONS		In Inches COMMON DIMENSIONS	
	MIN	MAX	MIN	MAX
A	--	1.20	--	.047
A1	0.05	0.15	.002	.006
A2	0.80	1.05	.032	.041
b	0.19	0.30	.007	.012
c	0.09	0.20	.0035	.008
D	SEE VARIATIONS		SEE VARIATIONS	
E	6.40 BASIC		0.252 BASIC	
E1	4.30	4.50	.169	.177
e	0.65 BASIC		0.0256 BASIC	
L	0.45	0.75	.018	.030
N	SEE VARIATIONS		SEE VARIATIONS	
alpha	0°	8°	0°	8°
aaa	--	0.10	--	.004

**VARIATIONS**

N	D mm.		D (inch)	
	MIN	MAX	MIN	MAX
8	2.90	3.10	.114	.122

Reference Doc.: JEDEC Publication 95, MO-153

10-0035

**Ordering Information**

**ICS91720yGLF-T**

Example:

**ICS XXXX y G LF-T**

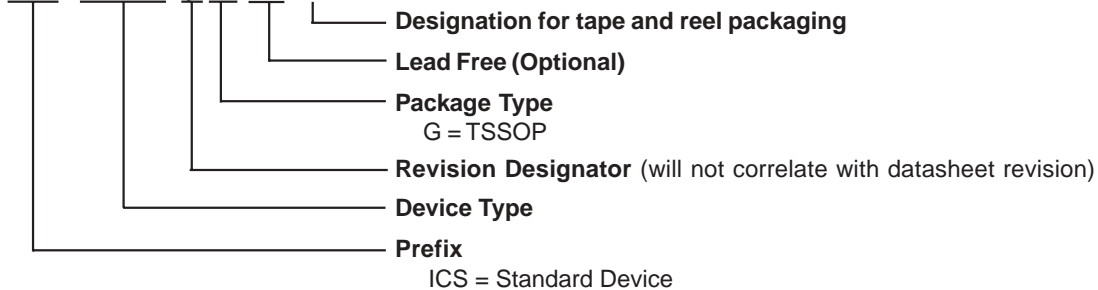

## IMPORTANT NOTICE AND DISCLAIMER

RENESAS ELECTRONICS CORPORATION AND ITS SUBSIDIARIES (“RENESAS”) PROVIDES TECHNICAL SPECIFICATIONS AND RELIABILITY DATA (INCLUDING DATASHEETS), DESIGN RESOURCES (INCLUDING REFERENCE DESIGNS), APPLICATION OR OTHER DESIGN ADVICE, WEB TOOLS, SAFETY INFORMATION, AND OTHER RESOURCES “AS IS” AND WITH ALL FAULTS, AND DISCLAIMS ALL WARRANTIES, EXPRESS OR IMPLIED, INCLUDING, WITHOUT LIMITATION, ANY IMPLIED WARRANTIES OF MERCHANTABILITY, FITNESS FOR A PARTICULAR PURPOSE, OR NON-INFRINGEMENT OF THIRD-PARTY INTELLECTUAL PROPERTY RIGHTS.

These resources are intended for developers who are designing with Renesas products. You are solely responsible for (1) selecting the appropriate products for your application, (2) designing, validating, and testing your application, and (3) ensuring your application meets applicable standards, and any other safety, security, or other requirements. These resources are subject to change without notice. Renesas grants you permission to use these resources only to develop an application that uses Renesas products. Other reproduction or use of these resources is strictly prohibited. No license is granted to any other Renesas intellectual property or to any third-party intellectual property. Renesas disclaims responsibility for, and you will fully indemnify Renesas and its representatives against, any claims, damages, costs, losses, or liabilities arising from your use of these resources. Renesas' products are provided only subject to Renesas' Terms and Conditions of Sale or other applicable terms agreed to in writing. No use of any Renesas resources expands or otherwise alters any applicable warranties or warranty disclaimers for these products.

(Disclaimer Rev.1.01)

### Corporate Headquarters

TOYOSU FORESIA, 3-2-24 Toyosu,  
Koto-ku, Tokyo 135-0061, Japan  
[www.renesas.com](http://www.renesas.com)

### Trademarks

Renesas and the Renesas logo are trademarks of Renesas Electronics Corporation. All trademarks and registered trademarks are the property of their respective owners.

### Contact Information

For further information on a product, technology, the most up-to-date version of a document, or your nearest sales office, please visit [www.renesas.com/contact-us/](http://www.renesas.com/contact-us/).