



Direct Rambus™ Clock Generator

General Description

The **ICS9212-13** is a High-speed clock generator providing up to 600 MHz differential clock source for direct Rambus™ memory system. It includes DDLL (Distributed Delay locked loop) and phase detection mechanism to synchronize the direct Rambus™ channel clock to an external system clock. **ICS9212-13** provides a solution for a broad range of Direct Rambus memory applications. The device works in conjunction with the ICS9250-09.

The **ICS9212-13** power management support system turns “off” the Rambus™ channel clock to minimize power consumption for mobile and other power-sensitive applications. In “clock off” mode the device remains “on” while the output is disabled, allowing fast transitions between clock-off and clock-on states. In “power down” mode it completely powers down for minimum power dissipation.

The **ICS9212-13** meets the requirements for input frequency tracking when the input frequency clock is using Spread Spectrum clocking and also the optimum bandwidth is maintained while attenuating the jitter of the reference signal.

Features

- Compatible with all Direct Rambus™ based IC s
- Up to 600 MHz differential clock source for direct Rambus™ memory system
- Cycle to cycle jitter is less than 40ps
- $3.3 \pm 5\%$ supply
- Synchronization flexibility: Supports Systems that need clock domains of Rambus channel to synchronize with system or processor clock, or systems that do not require synchronization of the Rambus clock to another system clock
- Excellent power management support
- REFCLK input is from the ICS9250-09.

Block Diagram

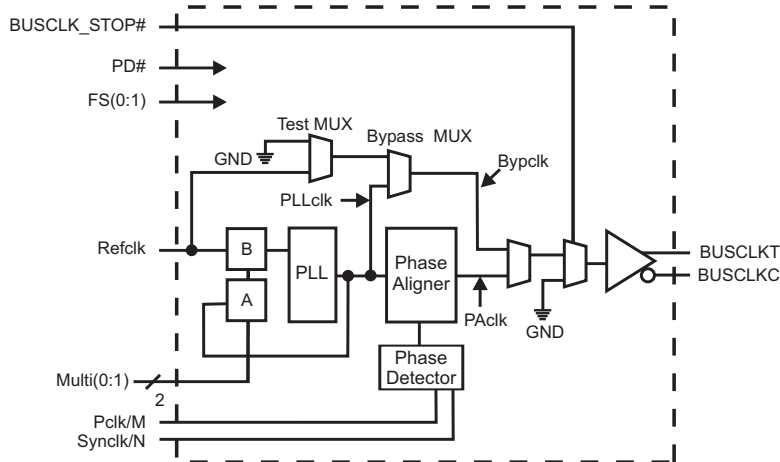

Pin Configuration

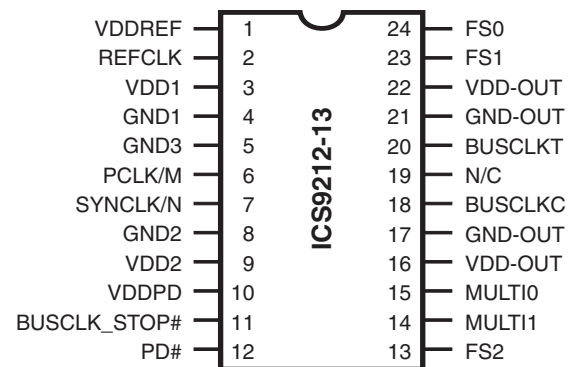

24-Pin 150 Mil SSOP

Pin Descriptions

Pin #	Name	Type	Description
1	VDDREF	REFV	Reference voltage for refclk, to be connected to CK133
2	REFCLK	IN	Reference clock, to be connected to CK133
3	VDD1	PWR	3.3 V power supply used for PLL
4	GND1	PWR	Ground for PLL
5	GND3	PWR	Ground for control inputs
6,7	PCLK/M, SYNCLK/N	IN	Phase controller input, used to drive a phase aligner that adjusts the phase of the busclk.
8	GND2	PWR	Ground for phase aligner
9	VDD2	PWR	3.3 V power supply used for phase aligner
10	VDDPD	REFV	Reference voltage for phase detector inputs connected to the controller
11	BUSCLK_STOP#	IN	Active low output enable/disable
12	PD#	IN	3.3V CMOS active low power down, the device is powered down when the "(PD#) =0"
14,15	MULTI (0:1)	IN	3.3V CMOS PLL Multiplier select, logic for selecting the multiply ratio for the PLL from the input REFCLK
16	VDD_OUT	PWR	3.3V supply for clock out puts
17	GND_OUT	PWR	Ground for clock outputs
18	BUSCLKC	OUT	Out put clock connected to the Rambus channel. This output is the complement of BUSCLK
19	N/C	N/C	NOT USED
20	BUSCLKT	OUT	Output clock connected to the Rambus channel. This output is the true component of BUSCLK
21	GND_OUT	PWR	Ground for clock outputs
22	VDD_OUT	PWR	3.3V supply for clock out puts
13,23,24	FS(0:2)	IN	3.3V CMOS Mode control, used in selecting bypass, test, normal, and output test (OE)

PLL Divider Selection and PLL Values (PLLCLK = REFCLK*A/B)

Multo	Mult1	A	B	PLLCLK for REFCLK=50MHz	PLLCLK for REFCLK=66.66MHz
0	0	4	1	Reserved	266.6
0	1	6	1	300	400.0
1	0	16	3	266.7	355.5
1	1	8	1	400	533.3

Bypass and Test Mode Selection

Mode	FS0	FS1	FS2	Bypclk (int.)	BusClk	BusClkB
Normal	0	0	0	Gnd	PAclk	PAclkB
Bypass	1	0	0	PLLclk	PLLclk	PLLclkB
Test	1	1	0	Refclk	Refclk	RefclkB
Vendor Test A	0	0	1	-	-	-
Vendor Test B	1	0	1	-	-	-
Reserved	1	1	1	-	-	-
Output Test (OE)	0	1	X	-	Hi-Z	Hi-Z

Power Management Modes

State	PwrDnB	StopB
NORMAL	1	1
Clk Off	1	0
Powerdown	0	X

Absolute Maximum Ratings

Supply Voltage	4.0 V
Logic Inputs	GND -0.5 V to V _{DD} +0.5 V
Ambient Operating Temperature	0°C to +70°C
Storage Temperature	-65°C to +150°C

Stresses above those listed under *Absolute Maximum Ratings* may cause permanent damage to the device. These ratings are stress specifications only and functional operation of the device at these or any other conditions above those listed in the operational sections of the specifications is not implied. Exposure to absolute maximum rating conditions for extended periods may affect product reliability.

Electrical Characteristics-input/supply/Outputs

Parameters	Symbol	Min	Max	Unit
Supply Voltage	VDD	3.135	3.465	V
Refclk Input cycle time	t _{CYCLE,IN}	10	40	ns
Input cycle-to-cycle Jitter	t _{J,IN}	-	250	ps
Input Duty cycle over 10k cycles	DC _{IN}	40%	60%	t _{CYCLE}
Input frequency of modulation	F _{m,IN}	30	33	kHz
Modulation index	P _{M,IN}	0.25	0.5	%
Phase detector input cycle time at PDclk/M & Syncclk/N	t _{CYCLE,PD}	30	100	ns
Initial phase error at phase detector inputs	T _{err,init}	-0.5	0.5	t _{CYCLE,PD}
Phase detector input duty cycle over 10k cycles	DC _{IN,PD}	25%	75%	t _{CYCLE,PD}
Input rise & fall times (measured at 20%-80% of input voltage) for PDCLK/M & SYNCLK/N,&REFCLK	T _{IR} ,T _{IF}	-	1	ns
Input capacitance at PDCLK/M,Syncclk/N,&REFCLK	C _{IN,PD}	-	7	pF
Input Capacitance matching at PCLK/M & SYNCLK/N	DC _{IN,PD}	-	0.5	pF
Input capacitance at CMOS pins	C _{IN,CMOS}	-	10	pF
Input (CMOS) signal low voltage	V _{IL}	-	0.3	V _{dd}
Input (CMOS) signal high voltage	V _{IH}	0.7	-	V _{dd}
REFCLK input low voltage	V _{IL,R}	-	0.3	V _{ddi,R}
REFCLK input high voltage	V _{IH,R}	0.7	-	V _{ddi,R}
Input signal low voltage for PD inputs and STOP	V _{IL,PD}	-	0.3	V _{ddi,PD}
Input signal high voltage for PD inputs and STOP	V _{IH,PD}	0.7	-	V _{ddi,PD}
Input supply reference for REFCLK	V _{DD,IR}	1.3	3.465	V
Input supply reference vfor PD inputs	V _{DDI,PD}	1.3	3.465	V
Phase detector phase error for distributed loop measured at PDCLK/M & SYNCLK/N(rising)	t _{ERR,PD}	-100	100	ps
Cycle cycle time	t _{CYCLE}	2.5	3.75	ns
Cycle-to-cycle jitter at Busclk/BUSCLKB (533 MHz)	t _J	-	40	ps
Total jitter over 1 - 6 cycles (533MHz)	t _J	-	30	ps
Phase aligner, phase step size (BSCLK/BUSCLKB)	t _{STEP}	1	-	ps
PLL out put phase error when tracking SSC	t _{ERR,SSC}	-100	100	ps
Out put crossing-point voltage	V _X	1.3	1.8	V
Output voltage swing	V _{COS}	0.4	0.6	V
Output high voltage	V _H	-	2	V
Out put duty cycle over 10k cycle	DC	40%	60%	t _{CYCLE}
Output cycle -to-cycle duty cycle error	t _{DC,ERR}	-	50	ps
Output rise & fall times (measured at 20%-80% of output voltage)	t _{CR} ,t _{CF}	300	500	ps
Difference between rise and fall times on a single device(20%-80%)	t _{CR,CF}	-	100	ps
Operating Supply Current	I _{DD}		150	mA

Recommended Layout

General Layout Precautions:





- 1) Use a ground plane on the top layer of the PCB in all areas not used by traces.
- 2) Make all power traces and vias as wide as possible to lower inductance.

Capacitor Values:

C3 : 100pF ceramic

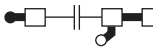
All unmarked capacitors are 0.01 μ F ceramic

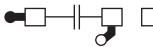
Connections to VDD:

-  Best
-  Okay
-  Avoid
-  Avoid

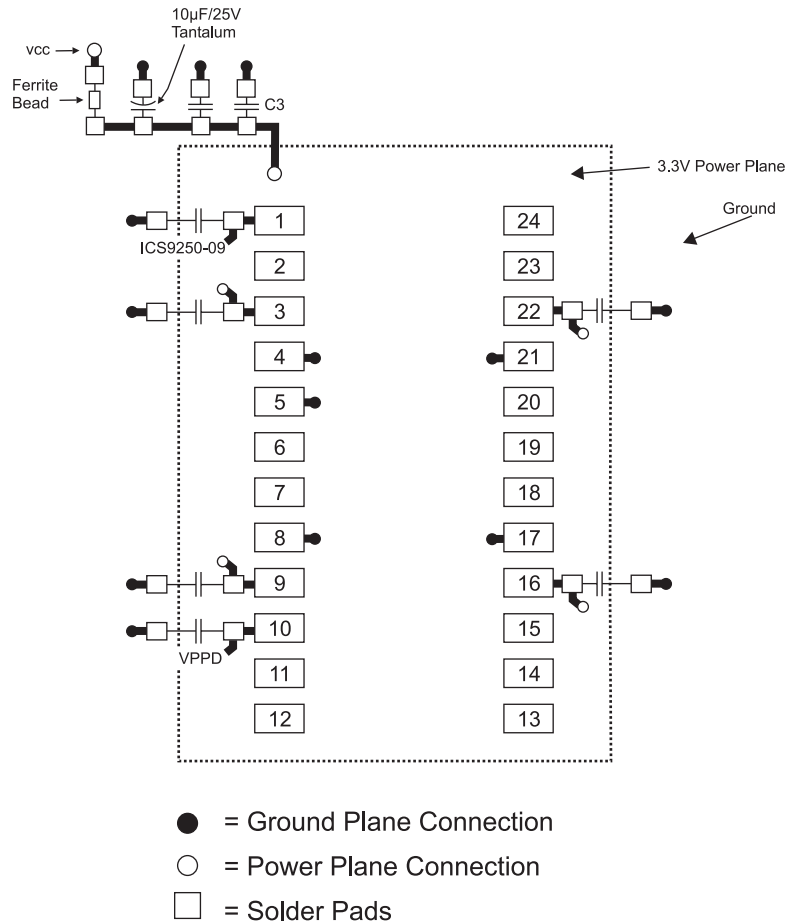

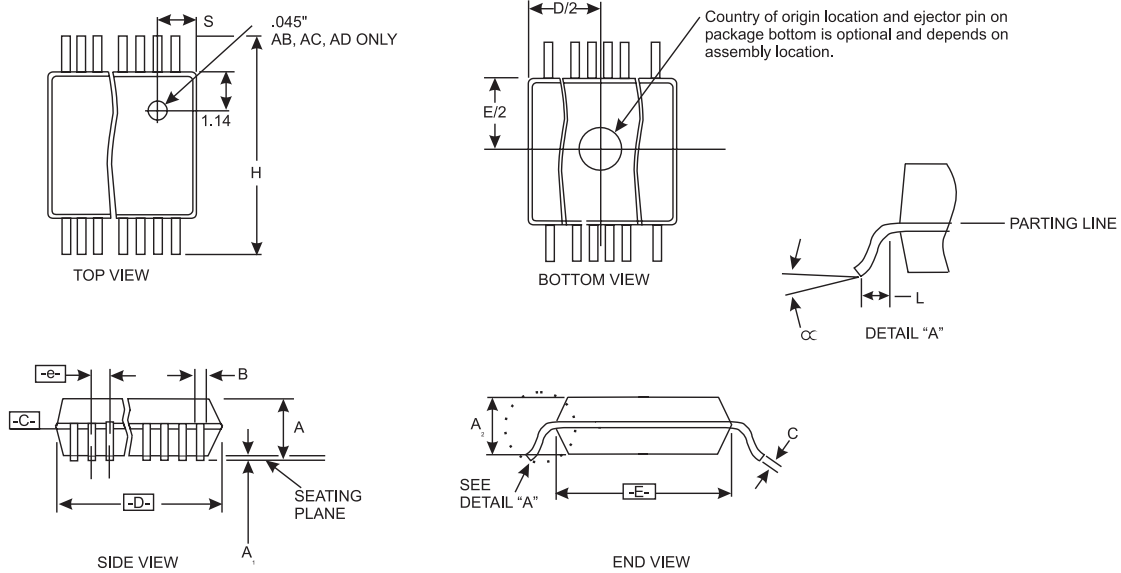

SYMBOL	COMMON DIMENSIONS			VARIATIONS	D			S			N
	MIN.	NOM.	MAX.		MIN.	NOM.	MAX.	MIN.	NOM.	MAX.	
A	.061	.064	.068	AA	.189	.194	.196	.0020	.0045	.0076	16
A1	.004	.006	.0098	AB	.337	.342	.344	.0500	.0525	.0550	20
A2	.055	.058	.061	AC	.337	.342	.344	.0250	.0275	.0300	24
B	.008	.010	.012	AD	.386	.391	.393	.0250	.0280	.0300	28
C	.0075	.008	.0098								
D	SEE VARIATIONS										
E	.150	.155	.157								
e	.025 BSC										
H	.230	.236	.244								
L	.010	.013	.016								
N	SEE VARIATIONS										
S	SEE VARIATIONS										
α	0°	5°	8°								
X	0.85	0.93	.100								

150 mil SSOP Package

Diminisions are in inches

Ordering Information

ICS9212yF-13LF

Example:

ICS XXXX y F - PPLF T

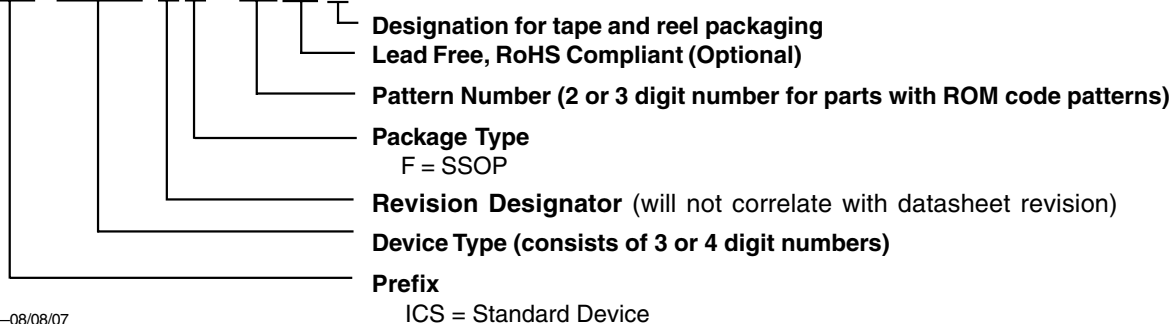

Revision History

Rev.	Issue Date	Description	Page #
F	08/08/07	Fixed typo on Electrical Characteristics.	4

IMPORTANT NOTICE AND DISCLAIMER

RENESAS ELECTRONICS CORPORATION AND ITS SUBSIDIARIES (“RENESAS”) PROVIDES TECHNICAL SPECIFICATIONS AND RELIABILITY DATA (INCLUDING DATASHEETS), DESIGN RESOURCES (INCLUDING REFERENCE DESIGNS), APPLICATION OR OTHER DESIGN ADVICE, WEB TOOLS, SAFETY INFORMATION, AND OTHER RESOURCES “AS IS” AND WITH ALL FAULTS, AND DISCLAIMS ALL WARRANTIES, EXPRESS OR IMPLIED, INCLUDING, WITHOUT LIMITATION, ANY IMPLIED WARRANTIES OF MERCHANTABILITY, FITNESS FOR A PARTICULAR PURPOSE, OR NON-INFRINGEMENT OF THIRD-PARTY INTELLECTUAL PROPERTY RIGHTS.

These resources are intended for developers who are designing with Renesas products. You are solely responsible for (1) selecting the appropriate products for your application, (2) designing, validating, and testing your application, and (3) ensuring your application meets applicable standards, and any other safety, security, or other requirements. These resources are subject to change without notice. Renesas grants you permission to use these resources only to develop an application that uses Renesas products. Other reproduction or use of these resources is strictly prohibited. No license is granted to any other Renesas intellectual property or to any third-party intellectual property. Renesas disclaims responsibility for, and you will fully indemnify Renesas and its representatives against, any claims, damages, costs, losses, or liabilities arising from your use of these resources. Renesas' products are provided only subject to Renesas' Terms and Conditions of Sale or other applicable terms agreed to in writing. No use of any Renesas resources expands or otherwise alters any applicable warranties or warranty disclaimers for these products.

(Disclaimer Rev.1.01)

Corporate Headquarters

TOYOSU FORESIA, 3-2-24 Toyosu,
Koto-ku, Tokyo 135-0061, Japan
www.renesas.com

Trademarks

Renesas and the Renesas logo are trademarks of Renesas Electronics Corporation. All trademarks and registered trademarks are the property of their respective owners.

Contact Information

For further information on a product, technology, the most up-to-date version of a document, or your nearest sales office, please visit www.renesas.com/contact-us/.