

General Description

The 8709311-01 is an LVC MOS clock generator that uses an internal phase lock loop (PLL) for frequency multiplication and to lock the low-skew outputs to the reference clock. The device offers six outputs. The PLL loop filter is completely internal and does not require external components. Several combinations of the PLL feedback and a divide-by-2 (controlled by `FREQ_SEL`) allow applications to optimize frequency generation over a wide range of input reference frequencies. The PLL can also be disabled by the `PLL_EN` control signal to allow for low frequency or DC testing. The 8709311-01 device is a member of the family of high performance clock solutions from IDT.

Features

- Single-ended input reference clock
- Six single-ended clock outputs
- Internal PLL does not require external loop filter components
- 5V tolerant inputs
- Maximum output frequency: 80MHz, (Q0:Q4 outputs)
- Maximum output frequency: 40MHz, (Q/2 output)
- LVC MOS interface levels for all inputs and outputs
- PLL disable feature for low-frequency testing
- Output drive capability: $\pm 24\text{mA}$
- Output skew: 300ps (maximum), Q0:Q4 and Q/2
- Full 3.3V supply voltage
- Available in lead-free packages
- -40°C to 85°C ambient operating temperature
- Fully pin and function compatible with the IDTQS5LV931 (including 50, 66 and 80MHz options)

Pin Assignment

GND	1	20	Q4
OE/mRST	2	19	Q/2
FEEDBACK	3	18	GND
AV _{DD}	4	17	Q3
V _{DD}	5	16	V _{DD}
AGND	6	15	Q2
SYNC	7	14	GND
FREQ_SEL	8	13	PLL_EN
GND	9	12	GND
Q0	10	11	Q1

8709311-01

20-Lead QSOP, 150Mil

3.9mm x 8.65mm x 1.5mm package body

R Package

Top View

Block Diagram

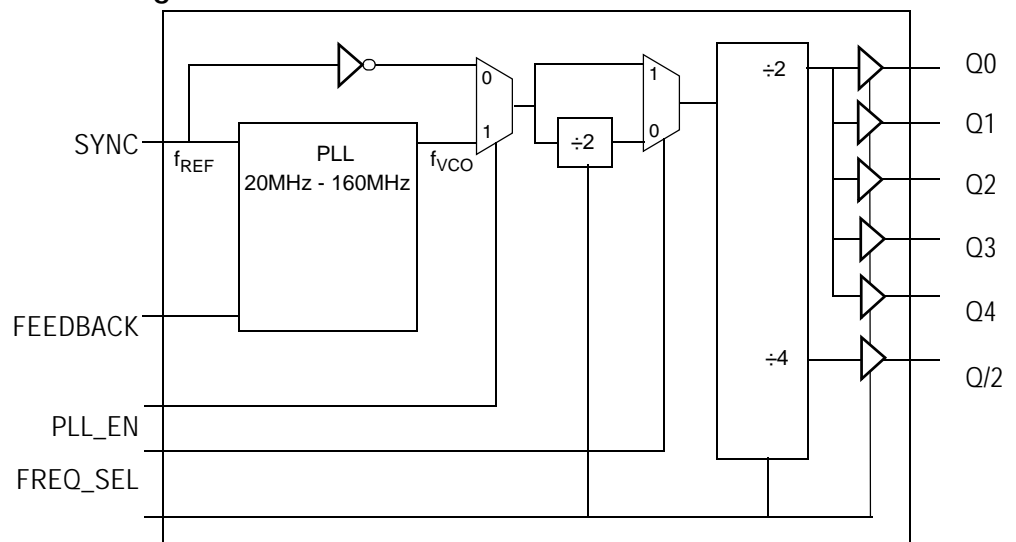

Table 1. Pin Descriptions

Number	Name	Type	Description
1, 9, 12, 14, 18	GND	Power	Power supply ground.
2	OE/nRST	Input	Output enable and asynchronous reset. Resets all outputs. Logic LOW, the outputs are in high-impedance state. Logic HIGH enables all outputs. LVCMOS/LVTTL interface levels.
3	FEEDBACK	Input	PLL feedback input which is connected to one of the clock outputs to close the PLL feedback loop. LVCMOS/LVTTL interface levels.
4	AV _{DD}	Power	Positive power supply for the PLL.
5, 16	V _{DD}	Power	Positive power supply pins.
6	AGND	Power	Power supply ground for the PLL.
7	SYNC	Input	Single-ended reference clock input. LVCMOS/LVTTL interface levels.
8	FREQ_SEL	Input	Frequency select. Logic LOW level inserts a divide-by-2 into the PLL output and feedback path. Logic HIGH inserts a divide-by-1 into the PLL output and feedback path. LVCMOS/LVTTL interface levels.
10, 11, 15, 17, 20	Q0, Q1, Q2, Q3, Q4	Output	Single-ended clock outputs. LVCMOS/LVTTL interface levels.
13	PLL_EN	Input	PLL enable. Enable and disables the PLL. Logic HIGH enables the PLL. Logic LOW disables the PLL and the input reference signal is routed to the output dividers (PLL bypass). LVCMOS/LVTTL interface levels.
19	Q/2	Output	Single-ended clock output. LVCMOS/LVTTL interface levels.

Table 2. Pin Characteristics

Symbol	Parameter	Test Conditions	Minimum	Typical	Maximum	Units
C _{IN}	Input Capacitance			4		pF
C _{PD}	Power Dissipation Capacitance	V _{DD} = AV _{DD} = 3.6V		330		pF
R _{OUT}	Output Impedance			11		Ω

Device Configuration

The 8709311-01 requires a connection to one of the clock outputs to the FEEDBACK input to close the PLL feedback path. The selection of the output (output divider) for PLL feedback will impact the device configuration and input to output frequency ratio and frequency ranges. See [Table 3D](#) for details.

Function Tables

Table 3A. OE/nRST Mode Configuration Table

Input	Operation
OE/nRST	
0	Device is reset and the outputs Q0:Q4 and Q/2 are in high-impedance state. This control is asynchronous.
1	Outputs are enabled.

Table 3B. FREQ_SEL Mode Configuration Table

Input	Operation
FREQ_SEL	
0	The VCO output is frequency-divided by 2. This setting allows for a lower input frequency range. See also table 3D for available frequency ranges.
1	The VCO output is frequency-divided by 1. This setting allows for a higher input frequency range. See also table 3D for available frequency ranges.

Table 3C. PLL_EN Mode Configuration Table

Input	Operation
PLL_EN	
0	The PLL is bypassed. The input reference clock is routed to the output dividers for low-frequency board test purpose. The PLL-related AC specifications do not apply in PLL bypass mode.
1	The PLL is enabled and locks to the input reference signal.

Table 3D. Frequency Configuration Table

Outputs Used for PLL Feedback	FREQ_SEL	Input Frequency Range (MHz)	Output Frequency Range (MHz) and Output-to-Input Frequency Multiplication Factor	
		SYNC	Q[0:4]	Q/2
Q0, Q1, Q2, Q3 or Q4	0	5 - 40	5 - 40 (1x)	2.5 - 20 (0.5x)
	1	10 - 80	10 - 80 (1x)	5 - 40 (0.5x)
Q/2	0	2.5 - 20	5 - 40 (2x)	2.5 - 20 (1x)
	1	5 - 40	10 - 80 (2x)	5 - 40 (1x)

Absolute Maximum Ratings

NOTE: Stresses beyond those listed under *Absolute Maximum Ratings* may cause permanent damage to the device. These ratings are stress specifications only. Functional operation of product at these conditions or any conditions beyond those listed in the *DC Characteristics* or *AC Characteristics* is not implied. Exposure to absolute maximum rating conditions for extended periods may affect product reliability.

Item	Rating
Supply Voltage, V_{DD}	4.6V
Inputs, V_I	-0.5V to $V_{DD} + 0.5V$
Outputs, V_O	-0.5V to $V_{DD} + 0.5V$
Package Thermal Impedance, θ_{JA}	72.3°C/W (0 lfpm)
Storage Temperature, T_{STG}	-65°C to 150°C

DC Electrical Characteristics

Table 4A. Power Supply DC Characteristics, $V_{DD} = AV_{DD} = 3.3V \pm 0.3V$, $T_A = -40^\circ C$ to $85^\circ C$

Symbol	Parameter	Test Conditions	Minimum	Typical	Maximum	Units
V_{DD}, AV_{DD}	Positive Supply Voltage		3.0	3.3	3.6	V
I_{DDQ}	Quiescent Power Supply Current	$V_{DD} = AV_{DD} = \text{Max.}$, OE/nRST = 0, SYNC = 0, All Outputs Open			5	mA

Table 4B. LVCMOS/LVTTL DC Characteristics, $V_{DD} = AV_{DD} = 3.3V \pm 0.3V$, $T_A = -40^\circ C$ to $85^\circ C$

Symbol	Parameter		Test Conditions	Minimum	Typical	Maximum	Units
V_{IH}	Input High Voltage			2		$V_{DD} + 0.3$	V
V_{IL}	Input Low Voltage			-0.3		0.8	V
I_{IH}	Input High Current	SYNC, OE/nRST, FEEDBACK, PLL_EN, FREQ_SEL	$V_{DD} = V_{IN} = 3.3V$			5	μA
I_{IL}	Input Low Current	SYNC, OE/nRST, FEEDBACK, PLL_EN, FREQ_SEL	$V_{DD} = 3.3V, V_{IN} = 0V$	-5			μA
V_{OH}	Output High Voltage:	Q0:Q4, Q/2	$I_{OH} = -24 \text{ mA}$	2.6			V
V_{OL}	Output Low Voltage	Q0:Q4, Q/2	$I_{OL} = 24 \text{ mA}$			0.5	V
I_{OZ}	Output Leakage Current	Q0:Q4, Q/2	OE/nRST = 0, $V_{OUT} = 0V$ or V_{DD} , $V_{DD} = 3.6V$			± 5	μA

Table 5. AC Electrical Characteristics, $V_{DD} = AV_{DD} = 3.3V \pm 0.3V$, $T_A = -40^{\circ}C$ to $85^{\circ}C$

Symbol	Parameter	Test Conditions	Minimum	Typical	Maximum	Units
f_{REF}	SYNC Input Reference Frequency	Feedback of Q0:Q4, FREQ_SEL = 0	5		40	MHz
		Feedback of Q0:Q4, FREQ_SEL = 1	10		80	MHz
		Feedback of Q/2, FREQ_SEL = 0	2.5		20	MHz
		Feedback of Q/2, FREQ_SEL = 1	5		40	MHz
f_{OUT}	Output Frequency	Q0-Q4			80	MHz
		Q/2			40	MHz
idc	Input Duty Cycle	SYNC	25		75	%
t_R / t_F	Input Rise/ Fall Time	SYNC			3	ns
$tsk(o)$	Output Skew; NOTE 1, 2, 3	Rising edges of Q0:Q4 and Q/2			300	ps
	Output Skew; NOTE 1, 2, 3	Falling edges of Q0:Q4			300	ps
t_{PW}	Output Pulse Width	Q0:Q4	80MHz	$t_{PERIOD}/2 - 0.5$	$t_{PERIOD}/2 + 0.5$	ns
		Q/2	40MHz	$t_{PERIOD}/2 - 0.4$	$t_{PERIOD}/2 + 0.4$	ns
$t_{jit(cc)}$	Cycle-to-Cycle Jitter	Feedback = Q			320	ps
		Feedback = Q/2			530	ps
$t(\phi)$	Static Phase Offset, (SYNC to FEEDBACK delay); NOTE 2, 4	Q0:Q4	80MHz	-500	500	ps
t_{PZL}	Output Enable Time; NOTE 5	OE/nRST	Low-to-High		14	ns
t_{PHZ} , t_{PLZ}	Output Disable Time; NOTE 5	OE/nRST	High-to-Low		14	ns
t_R / t_F	Output Rise/ Fall Time	Q0:Q4, Q/2	0.8V – 2.0V	0.2	2	ns
t_{LOCK}	PLL Lock Time				10	ms

NOTE: Electrical parameters are guaranteed over the specified ambient operating temperature range, which is established when the device is mounted in a test socket with maintained transverse airflow greater than 500 lfm. The device will meet specifications after thermal equilibrium has been reached under these conditions.

NOTE 1: Defined as skew between outputs at the same supply voltage and with equal load conditions. Measured at $V_{DD}/2$.

NOTE 2: This parameter is defined in accordance with JEDEC Standard 65.

NOTE 3: Measured between coincident rising output edges of Q0:Q4 and Q/2.

NOTE 4: Defined as the time difference between the input reference clock and the average feedback input signal when the PLL is locked and the input reference frequency is stable.

NOTE 5: These parameters are guaranteed by characterization. Not tested in production.

Parameter Measurement Information

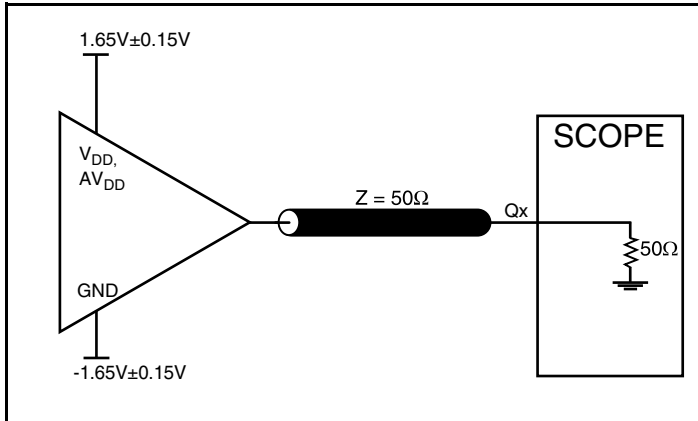

3.3V Output Load AC Test Circuit

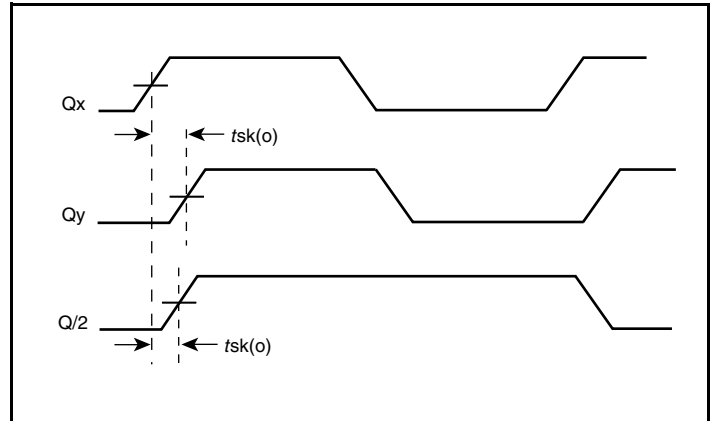

Output Skew

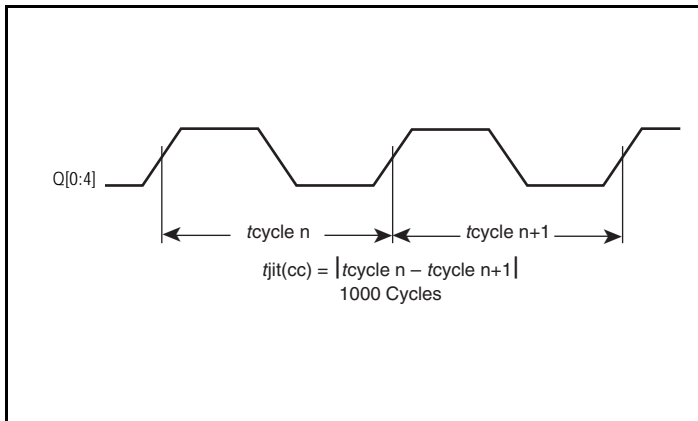

Cycle-to-Cycle Jitter

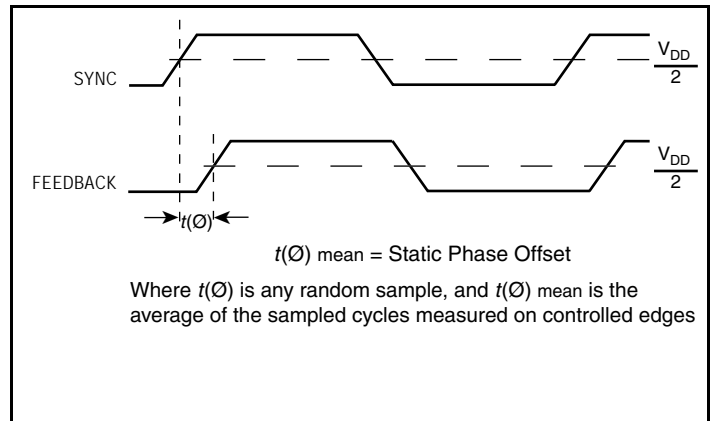

Static Phase Offset

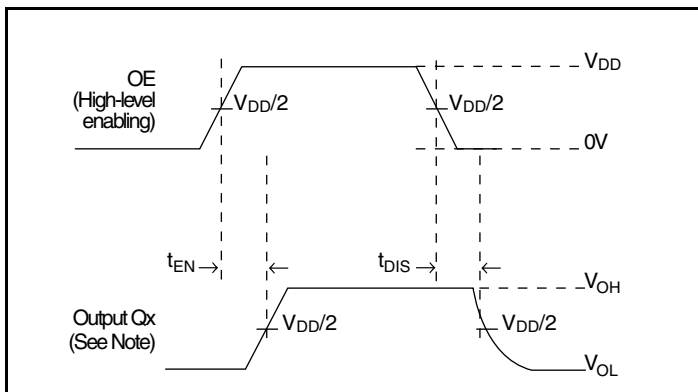

Output Enable/Disable

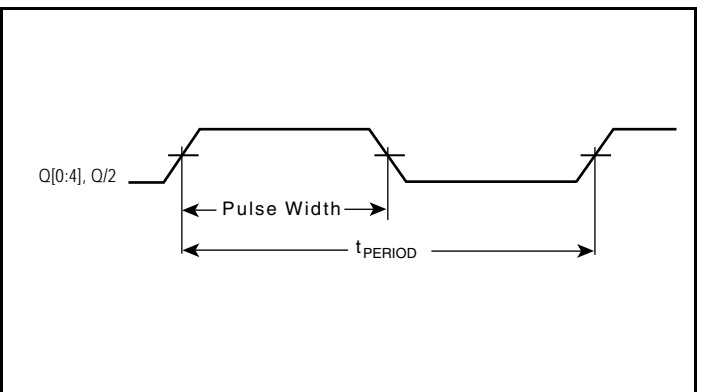

Output Pulse Width

Parameter Measurement Information, continued

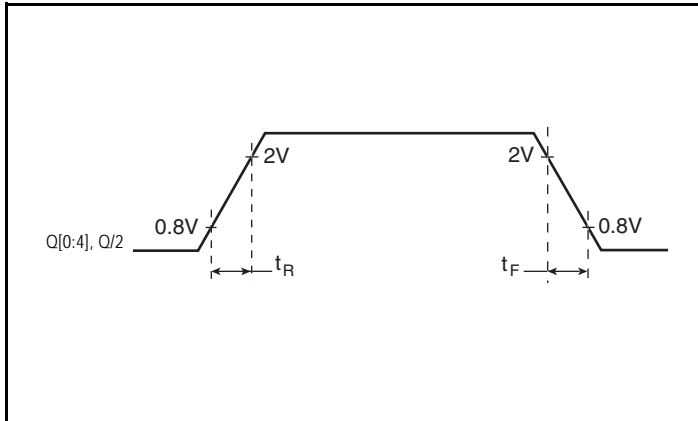

Output Rise/Fall Time

Application Information

Recommendations for Unused Output Pins

Outputs:

LVC MOS Outputs

All unused LVC MOS output can be left floating. There should be no trace attached.

Schematic Example

Figure 1 shows an example of an 8709311-01 application schematic. In this example, the device is operated at $V_{DD} = 3.3V$. The decoupling capacitors should be located as close as possible to the

power pin. The input is driven by a 3.3V LVCMOS driver. An example of LVCMOS termination is shown in this schematic.

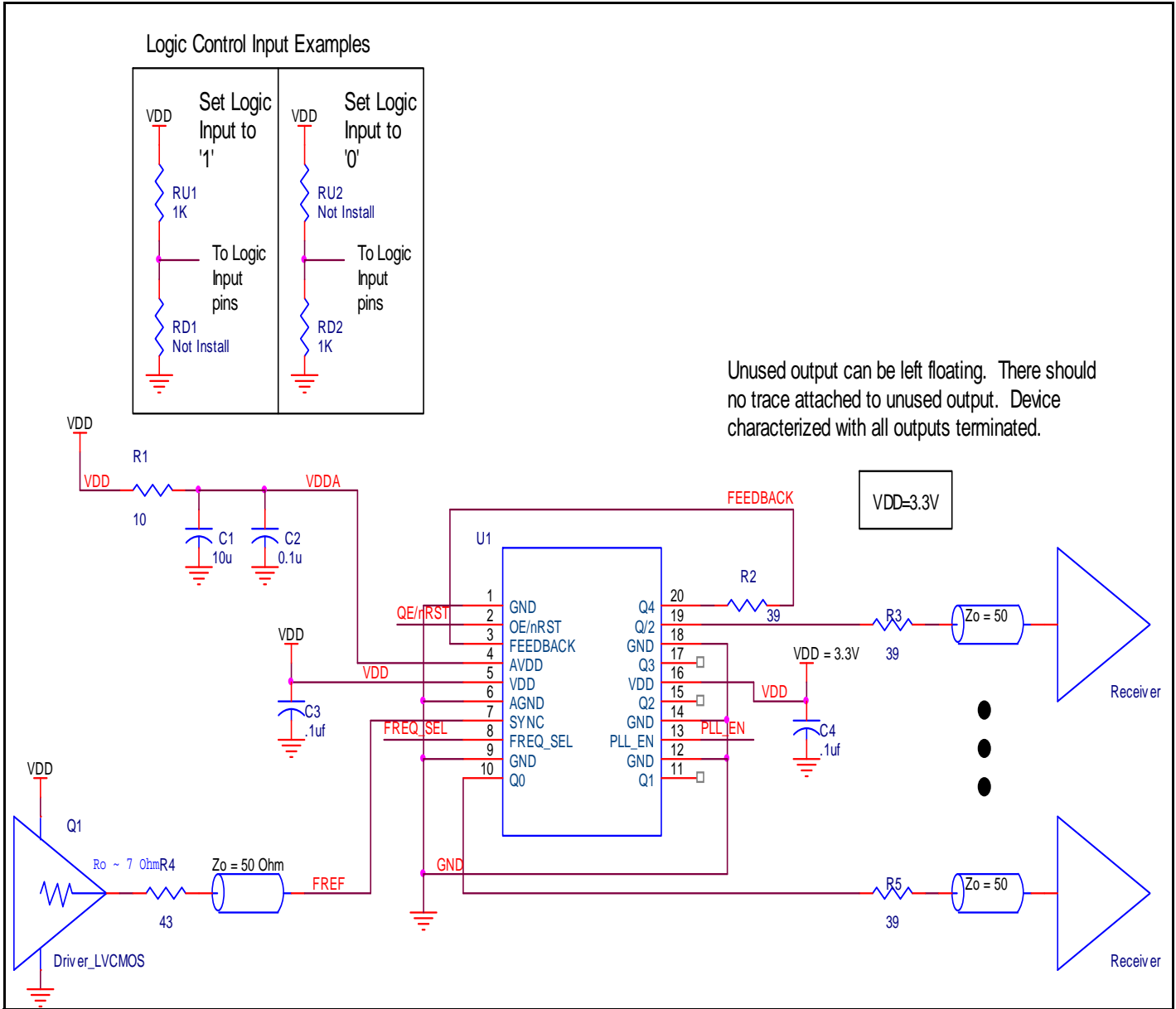

Figure 1. 8709311-01 Schematic Layout Example

Power Considerations

This section provides information on power dissipation and junction temperature for the 8709311-01. Equations and example calculations are also provided.

1. Power Dissipation.

The total power dissipation for the 8709311-01 is the sum of the core power plus the power dissipated in the load(s). The following is the power dissipation for $V_{DD} = 3.3V + 0.3V = 3.6V$, which gives worst case results.

- Power (core)_{MAX} = $V_{DD_MAX} * I_{DD_MAX} = 3.6V * 5mA = 18mW$
- Output Impedance R_{OUT} Power Dissipation due to Loading 50Ω to $V_{DD}/2$
Output Current $I_{OUT} = V_{DD_MAX} / [2 * (50\Omega + R_{OUT})] = 3.6V / [2 * (50\Omega + 11\Omega)] = 29.5mA$
- Power Dissipation on the R_{OUT} per LVCMOS output
Power (R_{OUT}) = $R_{OUT} * (I_{OUT})^2 = 11\Omega * (29.5mA)^2 = 9.57mW$ per output
- Total Power (R_{OUT}) = R_{OUT} (per output) * number of outputs = $9.57mW * 6$ outputs = **57.42mW**

Dynamic Power Dissipation at 80MHz

$$\text{Power (80MHz)} = C_{PD} * \text{Frequency} * (V_{DD})^2 = 330pF * 80MHz * (3.6V)^2 = 342mW$$

Total Power

$$\begin{aligned} &= \text{Power (core)}_{MAX} + \text{Total Power (} R_{OUT} \text{)} + \text{Power (80MHz)} \\ &= 18mW + 57.42mW + 342mW \\ &= \mathbf{417.42mW} \end{aligned}$$

2. Junction Temperature.

Junction temperature, T_j , is the temperature at the junction of the bond wire and bond pad and directly affects the reliability of the device. The maximum recommended junction temperature for HiPerClockS devices is $125^\circ C$.

The equation for T_j is as follows: $T_j = \theta_{JA} * Pd_total + T_A$

T_j = Junction Temperature

θ_{JA} = Junction-to-Ambient Thermal Resistance

Pd_total = Total Device Power Dissipation (example calculation is in section 1 above)

T_A = Ambient Temperature

In order to calculate junction temperature, the appropriate junction-to-ambient thermal resistance θ_{JA} must be used. Assuming no air flow and a multi-layer board, the appropriate value is $72.3^\circ C/W$ per Table 6 below.

Therefore, T_j for an ambient temperature of $85^\circ C$ with all outputs switching is:

$$85^\circ C + 0.417W * 72.3^\circ C/W = 115.1^\circ C. \text{ This is well below the limit of } 125^\circ C.$$

This calculation is only an example. T_j will obviously vary depending on the number of loaded outputs, supply voltage, air flow and the type of board (multi-layer).

Table 6. Thermal Resistance θ_{JA} for a 20 Lead QSOP, Forced Convection

θ_{JA} by Velocity			
Linear Feet per Minute	0	200	500
Multi-Layer PCB, JEDEC Standard Test Boards	$72.3^\circ C/W$	$64.4^\circ C/W$	$61.0^\circ C/W$

Reliability Information

Table 7. θ_{JA} vs. Air Flow Table for a 20 Lead QSOP

θ_{JA} vs. Air Flow			
Linear Feet per Minute	0	200	500
Multi-Layer PCB, JEDEC Standard Test Boards	72.3°C/W	64.4°C/W	61.0°C/W

Transistor Count

The transistor count for 870931I-01: 1489

Package Outline and Package Dimensions

Package Outline - R Suffix for 20 Lead QSOP, 150MIL

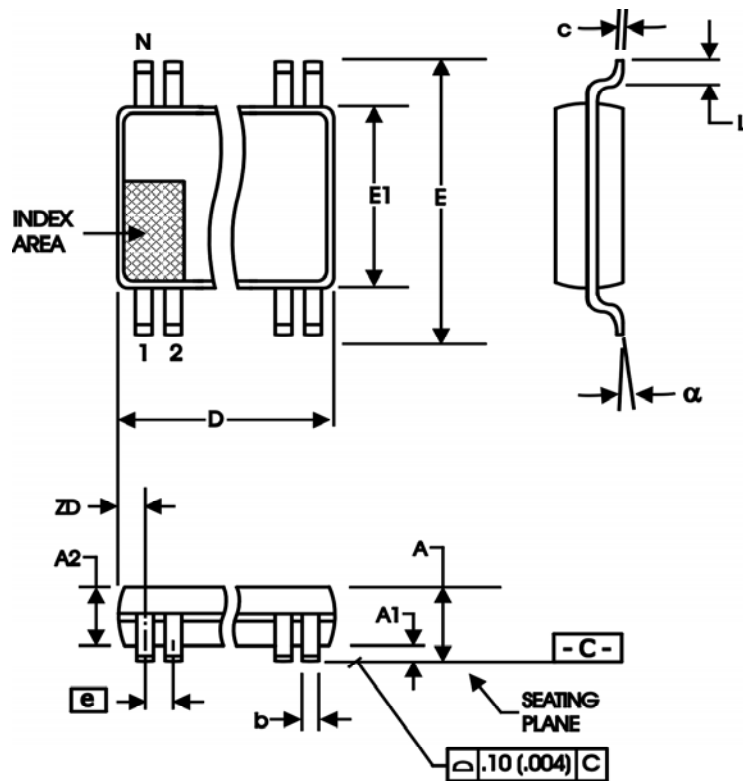

Table 8. Package Dimensions for 20 Lead QSOP

All Dimensions in Millimeters		
Symbol	Minimum	Maximum
N	20	
A	1.35	1.75
A1	0.10	0.25
A2	1.50	
b	0.20	0.30
c	0.18	0.25
D	8.55	8.750
E	5.80	6.20
E1	3.80	4.00
e	0.635 Basic	
L	0.40	1.27
α	0°	8°
ZD	1.47 Ref	

Reference Document: JEDEC Publication 95, MO-137

Ordering Information

Table 9. Ordering Information

Part/Order Number	Marking	Package	Shipping Packaging	Temperature
870931ARI-01LF	870931AI01L	"Lead-Free" 20 Lead QSOP	Tube	-40°C to 85°C
870931ARI-01LFT	870931AI01L	"Lead-Free" 20 Lead QSOP	Tape & Reel	-40°C to 85°C

Revision History Sheet

Rev	Table	Page	Description of Change	Date
A		8	Added Layout Schematic.	6/10/09
A	T9	11	Removed leaded orderable parts from the Ordering Information table	11/15/12
A	T9	1 11	Removed ICS from part number were needed. General Description - Deleted ICS Chip and HiperClocks. Ordering Information - Deleted LF note below table. Removed quantity for tape and reel. Updated header and footer.	1/27/16
B		1	Corrected header title.	4/25/16

IMPORTANT NOTICE AND DISCLAIMER

RENESAS ELECTRONICS CORPORATION AND ITS SUBSIDIARIES (“RENESAS”) PROVIDES TECHNICAL SPECIFICATIONS AND RELIABILITY DATA (INCLUDING DATASHEETS), DESIGN RESOURCES (INCLUDING REFERENCE DESIGNS), APPLICATION OR OTHER DESIGN ADVICE, WEB TOOLS, SAFETY INFORMATION, AND OTHER RESOURCES “AS IS” AND WITH ALL FAULTS, AND DISCLAIMS ALL WARRANTIES, EXPRESS OR IMPLIED, INCLUDING, WITHOUT LIMITATION, ANY IMPLIED WARRANTIES OF MERCHANTABILITY, FITNESS FOR A PARTICULAR PURPOSE, OR NON-INFRINGEMENT OF THIRD-PARTY INTELLECTUAL PROPERTY RIGHTS.

These resources are intended for developers who are designing with Renesas products. You are solely responsible for (1) selecting the appropriate products for your application, (2) designing, validating, and testing your application, and (3) ensuring your application meets applicable standards, and any other safety, security, or other requirements. These resources are subject to change without notice. Renesas grants you permission to use these resources only to develop an application that uses Renesas products. Other reproduction or use of these resources is strictly prohibited. No license is granted to any other Renesas intellectual property or to any third-party intellectual property. Renesas disclaims responsibility for, and you will fully indemnify Renesas and its representatives against, any claims, damages, costs, losses, or liabilities arising from your use of these resources. Renesas' products are provided only subject to Renesas' Terms and Conditions of Sale or other applicable terms agreed to in writing. No use of any Renesas resources expands or otherwise alters any applicable warranties or warranty disclaimers for these products.

(Disclaimer Rev.1.01 Jan 2024)

Corporate Headquarters

TOYOSU FORESIA, 3-2-24 Toyosu,
Koto-ku, Tokyo 135-0061, Japan
www.renesas.com

Trademarks

Renesas and the Renesas logo are trademarks of Renesas Electronics Corporation. All trademarks and registered trademarks are the property of their respective owners.

Contact Information

For further information on a product, technology, the most up-to-date version of a document, or your nearest sales office, please visit www.renesas.com/contact-us/.