

Introduction

RS flip flop or SR flip flop — is a circuit that keeps its previous state when both inputs are LOW, and changes its state when one of the inputs (Set or Reset) is HIGH.

If Set input goes HIGH, Output will go HIGH, and if Reset goes HIGH the Output will go LOW. In a classic cross coupled logic gate circuit, the output is undetermined when both inputs are HIGH. The design presented in this application note assigns priority to RS to solve that limitation.

RS flip flop circuit design

The RS flip flop circuit is presented in Figure1. In this realization it consists of two latch blocks, outputs of which are connected with the respective opposite blocks' CK inputs. Set and Reset signals are input on the latches' D input. PINs and latches properties are shown in Figure 2 and Figure 3.

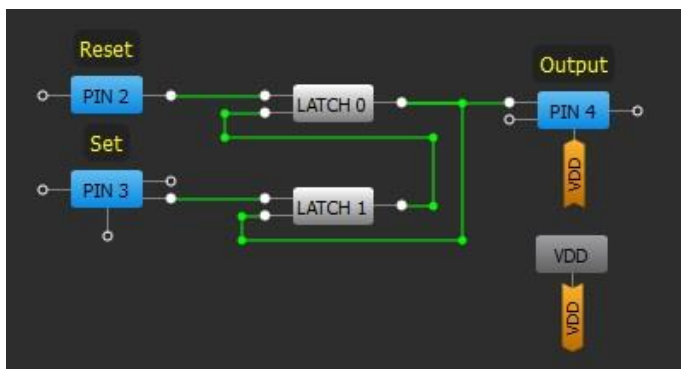

Figure 1. RS flip flop circuit design

PIN 2	
I/O selection:	Digital input
Input mode: OE = 0	Digital in without Sc
Output mode: OE = 1	None
Resistor:	Floating
Resistor value:	Floating
PIN 2	
Reset:	Disable
Bypass:	Edge active
Edge detect mode:	Rising edge
PIN 3	
I/O selection:	Digital input
Input mode: OE = 0	Digital in without Sc
Output mode: OE = 1	None
Resistor:	Floating
Resistor value:	Floating
PIN 4	
I/O selection:	Digital output
Input mode: OE = 0	None
Output mode: OE = 1	1x push pull
Resistor:	Floating
Resistor value:	Floating

Figure 2. PINs configuration



Figure 3. Latches configuration

RS flip flop circuit analysis

When a pulse comes from Set, the LATCH1 is not latched, because latches' outputs are inverted and LATCH1 initial polarity is HIGH. At this moment LATCH1 Q becomes LOW and LATCH0 Q – HIGH.

When a pulse comes from Reset, LATCH0 Q goes LOW and LATCH1 Q – HIGH, that provides reset function.

In this design, Reset input has higher priority than Set, which means that regardless of which signal comes first: Set or Reset, at the moment when these both inputs are HIGH Output will always stay LOW (See figure 4).

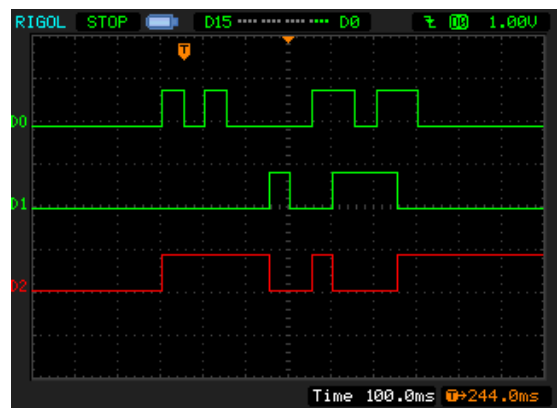

Figure 4. RS flip flop functional diagram
D0 –PIN#3 (Set); D1 – PIN#2 (Reset); D2 – PIN#4 (Output)

Conclusion

Using only two Latch blocks of GreenPAK silicon it is possible to create a circuit that functions as a RS flip flop with priority. This circuit is apt to be most useful in complicated designs where state machines are used.

IMPORTANT NOTICE AND DISCLAIMER

RENESAS ELECTRONICS CORPORATION AND ITS SUBSIDIARIES (“RENESAS”) PROVIDES TECHNICAL SPECIFICATIONS AND RELIABILITY DATA (INCLUDING DATASHEETS), DESIGN RESOURCES (INCLUDING REFERENCE DESIGNS), APPLICATION OR OTHER DESIGN ADVICE, WEB TOOLS, SAFETY INFORMATION, AND OTHER RESOURCES “AS IS” AND WITH ALL FAULTS, AND DISCLAIMS ALL WARRANTIES, EXPRESS OR IMPLIED, INCLUDING, WITHOUT LIMITATION, ANY IMPLIED WARRANTIES OF MERCHANTABILITY, FITNESS FOR A PARTICULAR PURPOSE, OR NON-INFRINGEMENT OF THIRD-PARTY INTELLECTUAL PROPERTY RIGHTS.

These resources are intended for developers who are designing with Renesas products. You are solely responsible for (1) selecting the appropriate products for your application, (2) designing, validating, and testing your application, and (3) ensuring your application meets applicable standards, and any other safety, security, or other requirements. These resources are subject to change without notice. Renesas grants you permission to use these resources only to develop an application that uses Renesas products. Other reproduction or use of these resources is strictly prohibited. No license is granted to any other Renesas intellectual property or to any third-party intellectual property. Renesas disclaims responsibility for, and you will fully indemnify Renesas and its representatives against, any claims, damages, costs, losses, or liabilities arising from your use of these resources. Renesas' products are provided only subject to Renesas' Terms and Conditions of Sale or other applicable terms agreed to in writing. No use of any Renesas resources expands or otherwise alters any applicable warranties or warranty disclaimers for these products.

(Disclaimer Rev.1.01 Jan 2024)

Corporate Headquarters

TOYOSU FORESIA, 3-2-24 Toyosu,
Koto-ku, Tokyo 135-0061, Japan
www.renesas.com

Trademarks

Renesas and the Renesas logo are trademarks of Renesas Electronics Corporation. All trademarks and registered trademarks are the property of their respective owners.

Contact Information

For further information on a product, technology, the most up-to-date version of a document, or your nearest sales office, please visit www.renesas.com/contact-us/.