

Introduction

This simple, compact, and low cost touch sensor can be used in many devices to detect fingers touching a surface or two-button area.

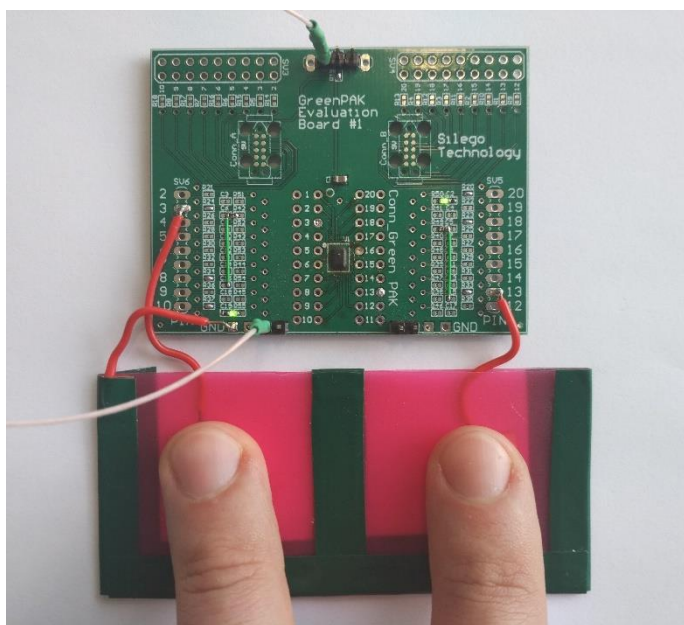

Figure 1. Touch sensor demo board

It operates because the additional capacitance added to the circuit by the fingers changes the frequency of a generator. While capacitance increases, frequency decreases. This change is detected by the GreenPAK. One SLG46620V is enough to implement two button touch sensors.

Touch sensor circuit design

At the core of this design are two independent generators (one generator per button) which consist of inverters with enables (2L0 and 2L4). Inputs (PIN# 3 and PIN# 13) and outputs (PIN# 8 and PIN# 18) are connected with 68K resistors (see Figure 2, Figure 3, Figure 4). Frequency associated with the resistance value is ~ 550 kHz.

When we change the resistance, the generator's frequency will change (the lower the resistance, the higher the frequency). Also, frequency varies because of external factors such as temperature, supply voltage, and normal chip to chip variation. That's why unidirectional self-tuning circuitry is used.

The characteristics of the design are as follows:

1. One reference generator, which generates pulses with duty cycle very close to 100%.
2. Two more generators for making pulses with the same frequency (synchronized by the falling edge), but with duty cycles that can be changed internally.
3. A tuning process adjusts the duty cycle.
4. To multiply (by 552) the frequency variation caused by touching a button, delay blocks CNT0/DLY0 and CNT1/DLY1 with clock sources (that are generators' outputs for each button) are used. If the button is touched, the frequency becomes lower and the subsequent delay will be longer. Changing duty cycle of the DLY's input signal, we can add or subtract additional delay and move the DLY's output rising edge. This is how the tuning is done.

CNT6/DLY6 is used as a reference delay (DLY). Initialization should be such that the output rising edges of the DLY0 and DLY1 should come earlier than the reference DLY's. When the circuit detects that the rising edges are not close enough (Pipe Delay0 - Pipe Delay1 OUT1 PD number withing 16 clocks), it generates a pulse which will maintain the appropriate FSM (FSM0, FSM1) for some period of time, decreasing the duty cycle of the reference generator. That adds additional delay for buttons' delays DLY0 and DLY1, and moves their outputs' rising edges closer to reference DLY output rising edge. As soon as both buttons' rising edges are close enough, 3L1 and 3L9 will latch High.

This means that the circuit is now tuned. Wake & sleep will be enabled, respective outputs PIN # 10 and PIN# 20 will go High, indicating that a button has been touched. Since the generators' frequency can vary over time and conditions, in some cases the circuit may need to be reset.

The reset functionality is achieved by Pipe Delay 0 and Pipe Delay 1 OUT0 outputs. Reset condition should be met 14 times in a row (defined by DLY7 counter data), for the system to get reset. After the reset, 3L1 and 3L9 will go Low and the FSMs will shift phase relatively to the CNT5 reference (which will be 0) as during initialization (see Figure 5).

Also, forced reset will be done when either buttons have been High for 20 sec or more. Reset is shared for both the buttons. As soon as the button is considered touched, it cannot cause system reset.

Wake and Sleep period is 50 ms. It is fast enough to detect touch and slow enough so that the sensor has low power consumption.

Unused PINs are configured as push-pull to be connected to external GND for noise suppression.

Although this design has self tuning capability and is quite stable, there are some considerations:

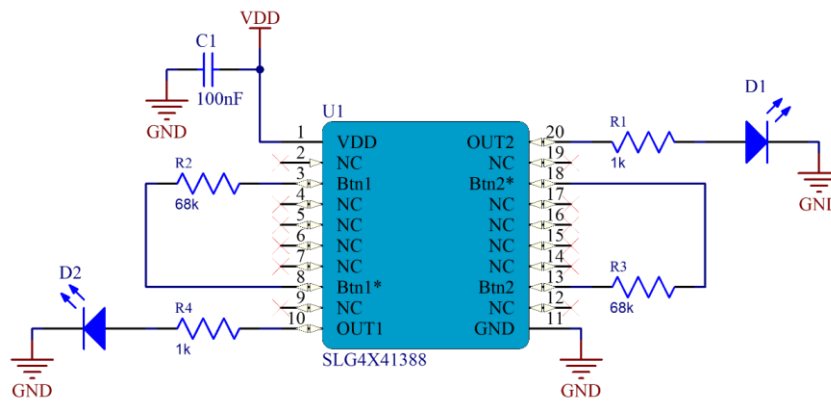

Figure 2. Touch Sensor circuit

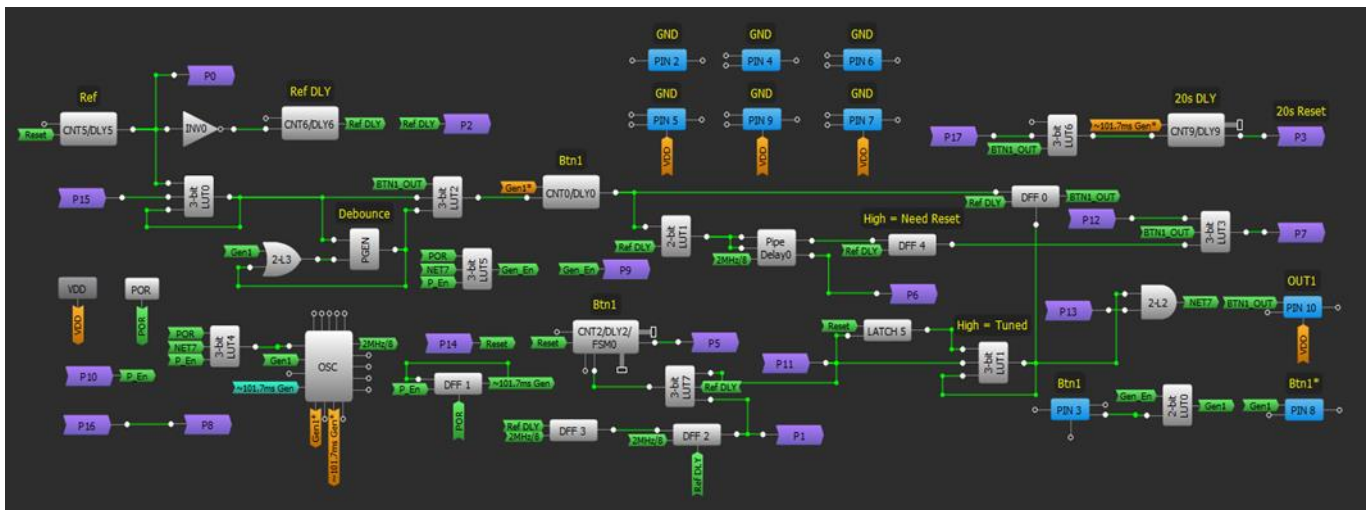

Figure 3. Touch Sensor design, Matrix0

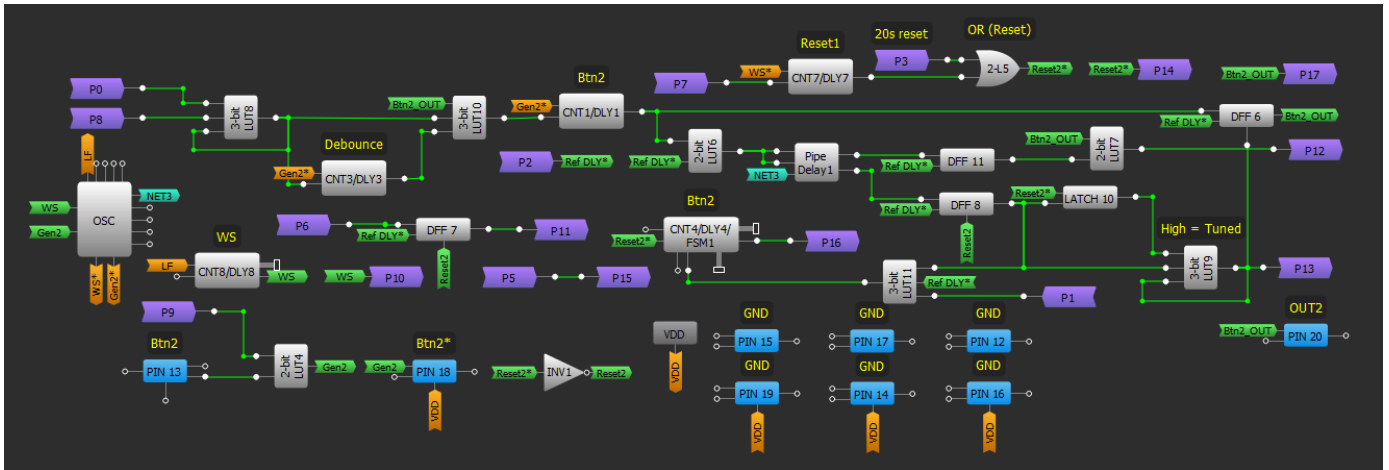

Figure 4. Touch Sensor design, Matrix 1

- 1) If either button had been touched while device was turning on, the corresponding output will remain Low. The other button should be operational. As soon as the touched button gets released, it too will operate properly.
- 2) Sensor cannot recognize slow approach (~1s touch).
- 3) Reset is shared. Both buttons are reset simultaneously.
- 4) If the first button is touched (first output is High) and the second one needs reset (voltage or temperature changed or because of slow approach), both buttons will be reset and both outputs will go Low.
- 5) If the VDD is decreasing faster than ~300mV/s, any output (or both of them) may latch High. They will go Low again if VDD returns higher than the VDD at the latching moment.
- 6) If the button is touched, it cannot be tuned. That's why if both the buttons are touched, the system cannot make the reset. If VDD decreases more than ~200-300mV, one or both outputs may latch High.
- 7) If the button is touched and the VDD increases more than ~200-300mV, the corresponding output will start blinking and go Low.
- 8) Touch pad size affects the generator's frequency and power consumption considerably. Additional capacitors can be added for each generator to lower the frequency. However, adding capacitors lowers the touch sensitivity.
- 9) Resistors' values can be increased to lower the frequency and power consumption. The generator's frequencies should be higher than 550kHz to keep the self-tuning system operational.

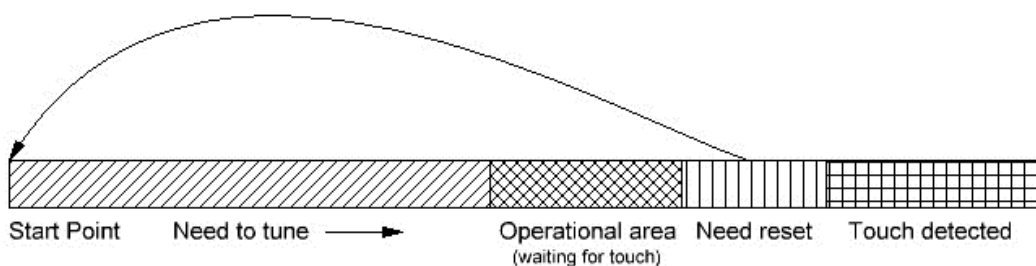

Figure 5. Touch Sensor states sequence

10) If the layout of touch pads are too close to each other, touching one can affect the other one. With that, one may observe that both outputs will go High, and the circuit will be reset after $\sim 1s$.

Conclusion

Using a single SLG46620V, it is possible to create an almost independent two-button self-tuning touch sensor which can be used in many compact and low cost devices.

IMPORTANT NOTICE AND DISCLAIMER

RENESAS ELECTRONICS CORPORATION AND ITS SUBSIDIARIES (“RENESAS”) PROVIDES TECHNICAL SPECIFICATIONS AND RELIABILITY DATA (INCLUDING DATASHEETS), DESIGN RESOURCES (INCLUDING REFERENCE DESIGNS), APPLICATION OR OTHER DESIGN ADVICE, WEB TOOLS, SAFETY INFORMATION, AND OTHER RESOURCES “AS IS” AND WITH ALL FAULTS, AND DISCLAIMS ALL WARRANTIES, EXPRESS OR IMPLIED, INCLUDING, WITHOUT LIMITATION, ANY IMPLIED WARRANTIES OF MERCHANTABILITY, FITNESS FOR A PARTICULAR PURPOSE, OR NON-INFRINGEMENT OF THIRD-PARTY INTELLECTUAL PROPERTY RIGHTS.

These resources are intended for developers who are designing with Renesas products. You are solely responsible for (1) selecting the appropriate products for your application, (2) designing, validating, and testing your application, and (3) ensuring your application meets applicable standards, and any other safety, security, or other requirements. These resources are subject to change without notice. Renesas grants you permission to use these resources only to develop an application that uses Renesas products. Other reproduction or use of these resources is strictly prohibited. No license is granted to any other Renesas intellectual property or to any third-party intellectual property. Renesas disclaims responsibility for, and you will fully indemnify Renesas and its representatives against, any claims, damages, costs, losses, or liabilities arising from your use of these resources. Renesas' products are provided only subject to Renesas' Terms and Conditions of Sale or other applicable terms agreed to in writing. No use of any Renesas resources expands or otherwise alters any applicable warranties or warranty disclaimers for these products.

(Disclaimer Rev.1.01)

Corporate Headquarters

TOYOSU FORESIA, 3-2-24 Toyosu,
Koto-ku, Tokyo 135-0061, Japan
www.renesas.com

Trademarks

Renesas and the Renesas logo are trademarks of Renesas Electronics Corporation. All trademarks and registered trademarks are the property of their respective owners.

Contact Information

For further information on a product, technology, the most up-to-date version of a document, or your nearest sales office, please visit www.renesas.com/contact-us/.