

# 120 degrees conducting control with hall IC

## RAJ306000 implementation guide

---

### Summary

This application note explains a sample program to support the drive by the 120 degrees conducting control with hall IC of 3-Phase brushless DC motor using RAJ306000, and the method using the library of development support tool "In Circuit Scope".

These sample programs are only to be used as reference and Renesas Electronics Corporation does not guarantee the operations. Please use them after carrying out a thorough evaluation in a suitable environment.

### Operation checking device

Operations of the sample program are checked by using the following device.

- RAJ306000

### Target of sample program

A sample program that this application note is intended shown below.

- RAJ306000\_HALL\_120\_OPEN\_CSP\_CA\_V107 (IDE: CS+ for CA, CX)
- RAJ306000\_HALL\_120\_OPEN\_CSP\_CC\_V107 (IDE: CS+ for CC)
- RAJ306000\_HALL\_120\_OPEN\_E2S\_CC\_V107 (IDE: e<sup>2</sup> studio)

120-degrees conducting control sample program with hall IC for RAJ306000  
(Complementary PWM Mode)

### Reference materials

- RL78/G1F User's Manual: Hardware (R01UH0516EJ0110)
- RAJ306000 Series User's Manual: Hardware (R18UZ0066EJ0100)
- In Circuit Scope Manual

Downloadable from: <http://www.desktoplab.co.jp/download.html>

## Contents

1. Overview .....	3
1.1 Development environment .....	3
2. System overview .....	5
2.1 Hardware configuration .....	6
2.2 Hardware specifications .....	8
2.2.1 User interface .....	8
2.2.2 Peripheral functions.....	11
2.3 Software structure .....	14
2.3.1 Software file structure.....	14
2.3.2 Module structure.....	16
2.4 Software specifications.....	17
3. Descriptions of control program .....	18
3.1 Contents of control .....	18
3.1.1 Motor start / stop.....	18
3.1.2 Rotation direction command value, Rotation speed command value, VM voltage.....	18
3.1.3 Rotation speed calculation .....	19
3.1.4 Voltage control by PWM.....	20
3.1.5 State transition.....	21
3.1.6 System protection function .....	22
3.1.7 System protect function (PreDriver safety function).....	22
3.2 Function specifications .....	23
3.3 Specification of variables.....	28
3.4 Specification of Macro definition.....	30
3.5 Flow chart .....	38
3.5.1 Main function .....	39
3.5.2 Initialization of PreDriver processing .....	40
3.5.3 Hall IC signal interruption processing.....	41
3.5.4 Carrier frequency interruption processing .....	42
3.5.5 500[us] interruption processing .....	43
3.5.6 ALARM interruption processing.....	44
3.5.7 ALARM recovery processing.....	45
4. Development support tool In Circuit Scope .....	46
4.1 Overview.....	46
4.2 How to use library.....	46
4.3 List of variables for ICS .....	47
Revision History .....	49

## 1. Overview

This application note explains a sample program to support the drive by the 120 degrees conducting control with hall IC of 3-Phase brushless DC motor using RAJ306000, and the method using the library of development support tool "In Circuit Scope". (Note 1).

Note:

1. The development support tool In Circuit Scope (ICS) is a product of Desk Top Laboratories Inc. Desk Top Laboratories Inc. (<http://www.desktoplab.co.jp/>)

### 1.1 Development environment

Development environment of the sample programs are showed in Table 1-1 and Table 1-2.

**Table 1-1 Software development environment**

<b>Integrated Development Environment</b>	CS+ for CA, CX V3.02.00 [15 Mar 2016]
<b>Compiler</b>	CA78K0R V1.72
<b>Integrated Development Environment</b>	CS+ for CC V6.01.00 [01 Dec 2017]
<b>Compiler</b>	CC-RL V1.06.00
<b>Integrated Development Environment</b>	e <sup>2</sup> studio Version: 5.4.0.015
<b>Compiler (Toolchain)</b>	CC-RL V1.06.00

Table 1-2 Hardware development environment

<b>On-chip Debugging Emulator</b>	RENESAS E1 Emulator (R0E000010KCE00)
<b>Operation Checking Device</b>	RAJ306000 (Note 2)
<b>RAJ306000 Series Evaluation Board</b>	RTK0EML2A0D00010BJ

Note:

- The configuration of RAJ306000 which is a SIP product containing MCU (RL78/G1F) and PreDriver is shown in Figure 1-1.

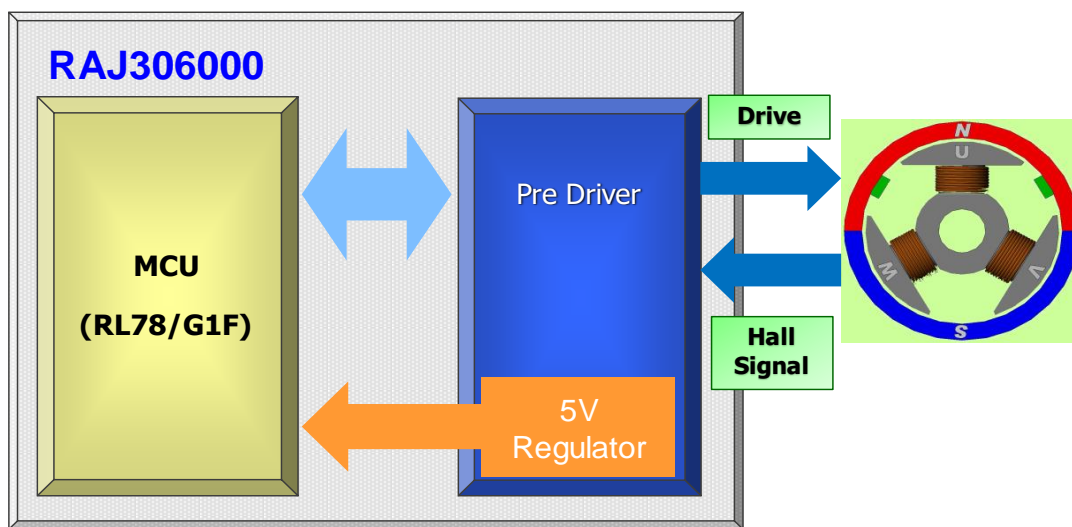

Figure 1-1 RAJ306000

## 2. System overview

Overview of RAJ306000 system is shown in Figure 2-1.

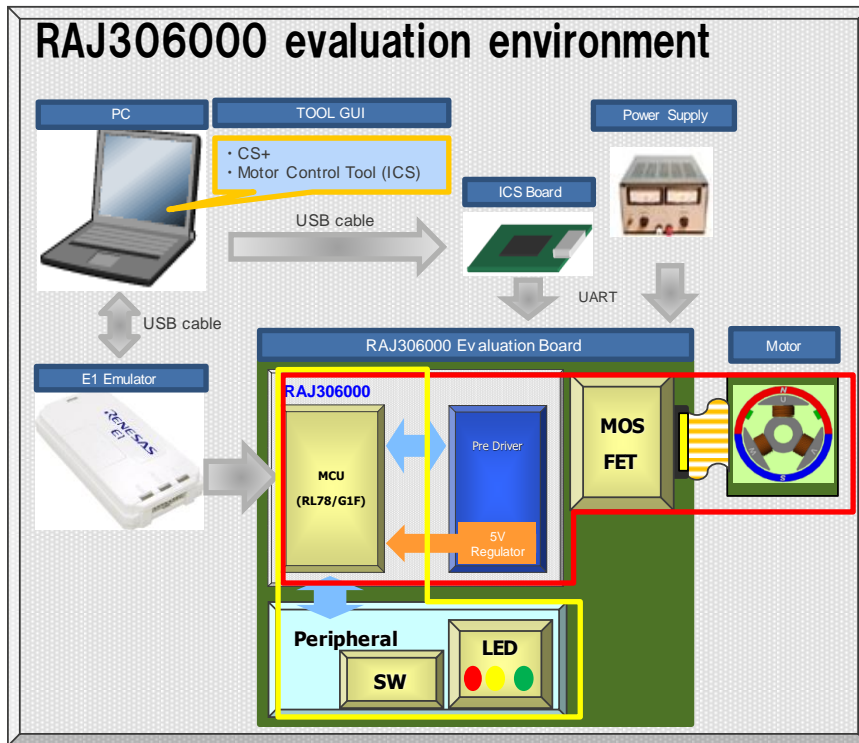

Figure 2-1 System configuration

### 2.1 Hardware configuration

Hardware configurations are shown below:

Figure 2-2 Hardware connection of between RL78/G1F and PreDriver.

Note: These are the hardware blocks highlighted in RED in Figure 2-1.

Figure 2-3 Hardware connection of between RL78/G1F and Peripheral.

Note: These are the hardware blocks highlighted in YELLOW in Figure 2-1.

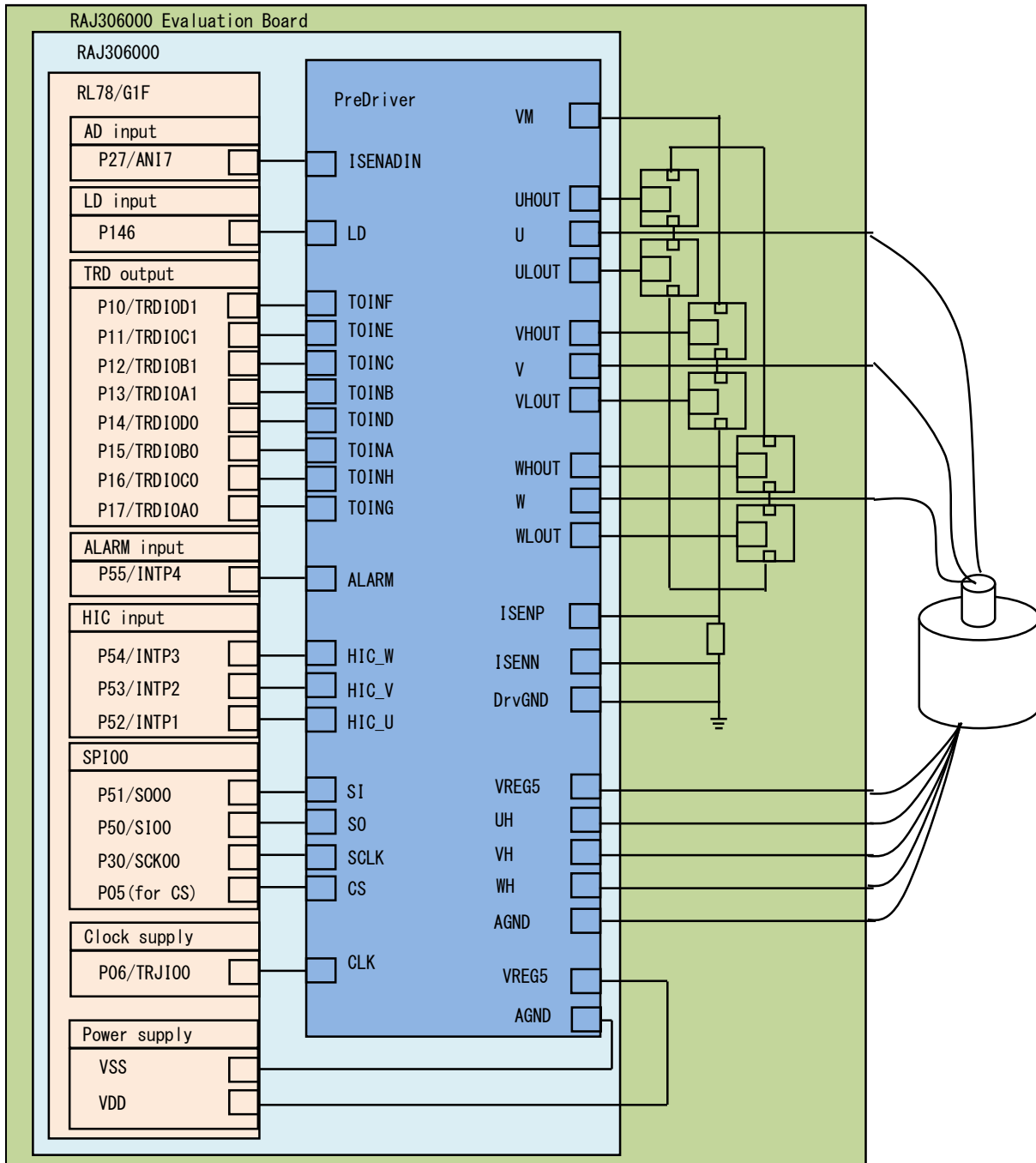

Figure 2-2 Hardware Configuration Diagram (RL78/G1F, PreDriver)

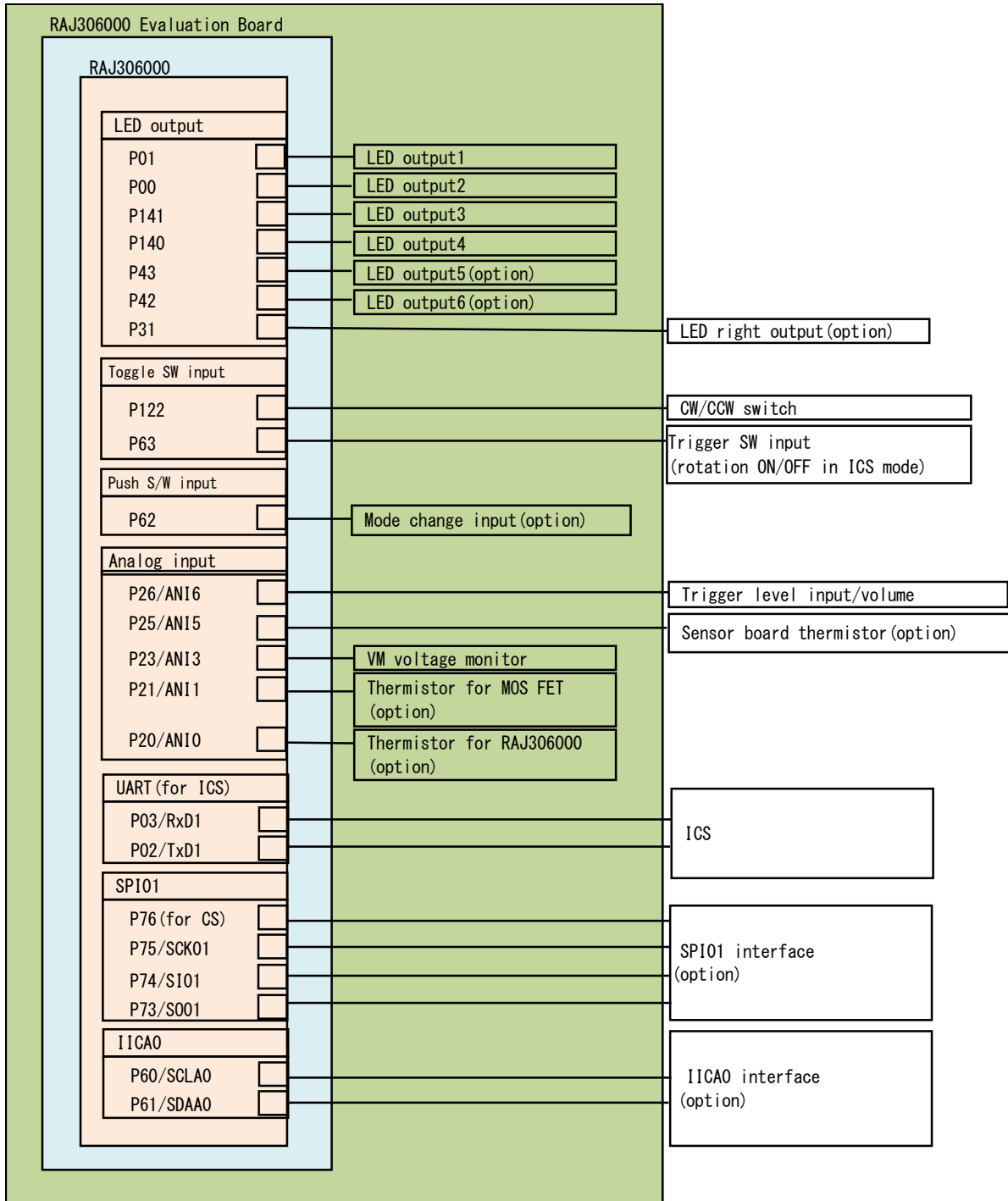

Figure 2-3 Hardware Configuration Diagram (RL78/G1F, Peripheral)

## 2.2 Hardware specifications

### 2.2.1 User interface

List of user interfaces of this system is shown in Table 2-1.

**Table 2-1 User Interface**

Item	Interface component	Function
Rotation direction	Selector switch of CW/CCW (SW1) or ICS	Input of rotation direction (CW/CCW)
Rotation speed	Input of trigger level/volume (VR1)	Rotation speed command value input (analog value)
START/STOP	Input of trigger level/volume (VR1) or ICS	Motor rotation start/stop command
RED LED	LED output1	<ul style="list-style-type: none"> <li>• At the time of normal operation: OFF</li> <li>• At the time of error detection: ON</li> </ul>
	LED output2	<ul style="list-style-type: none"> <li>• At the time of stop: OFF</li> <li>• At the time of Motor rotation: ON</li> </ul>
	LED output3	<ul style="list-style-type: none"> <li>• Rotation speed under 1500[rpm]: OFF</li> <li>• Rotation speed over 1500[rpm]: ON</li> </ul>
	LED output4	<ul style="list-style-type: none"> <li>• Rotation speed under 3000[rpm]: OFF</li> <li>• Rotation speed over 3000[rpm]: ON</li> </ul>
	LED output5	<ul style="list-style-type: none"> <li>• At the time of normal operation: OFF</li> <li>• At the time of error detection: ON</li> </ul>
	LED output6	<ul style="list-style-type: none"> <li>• At the time of normal operation: OFF</li> <li>• At the time of error detection: ON</li> </ul>
Over voltage and under voltage detection	VM voltage detection	VM voltage measurement (input)



List of interfaces of RL78/G1F micro controller of this system is shown in Table 2-2.

**Table 2-2 Port Interface (RL78/G1F)**

Terminal name	Function
P27/ANI7	PreDriver voltage measurement (input)
P10/TRDIOD1	Port output or PWM output ( $W_n$ )
P11/TRDIOC1	Port output or PWM output ( $V_n$ )
P12/TRDIOB1	Port output or PWM output ( $W_p$ )
P13/TRDIOA1	Port output or PWM output ( $V_p$ )
P14/TRDIOD0	Port output or PWM output ( $U_n$ )
P15/TRDIOB0	Port output or PWM output ( $U_p$ )
P55/INTP4	ALARM signal input
P54/INTP3	W phase hall IC signal input detection
P53/INTP2	V phase hall IC signal input detection
P52/INTP1	U phase hall IC signal input detection
P51/SO00	SPI data output for PreDriver control
P50/SI00	SPI data input for PreDriver control
P30/SCK00	SPI clock output for PreDriver control
P05 (CS)	SPI chip selection for PreDriver control
P06/TRJIO0	System clock output for PreDriver
VSS	Ground voltage
VDD	Positive power supply
P146, P16/TRDIOC0, P17/TRDIOA0	Unused terminal
P01	LED output1 ON/OFF control
P00	LED output2 ON/OFF control
P141	LED output3 ON/OFF control
P140	LED output4 ON/OFF control
P43	LED output5 ON/OFF control
P42	LED output6 ON/OFF control
P122	For rotation direction command value input (CW/CCW)
P26/ANI6	For rotation speed command value input (Analog value)
	Motor rotation start/stop command
P23/ANI3	VM voltage measurement (input)
P03/RxD1	UART input for ICS
P02/TxD1	UART output for ICS
P31, P63, P62, P25/ANI5, P21/ANI1, P20/ANI0 P76 (CS), P75/SCK01, P74/SI01, P73/SO01 P60/SCLA0, P61/SDLA0	Unused terminal

List of interfaces of PreDriver of this system is shown in Table 2-3.

**Table 2-3 Port Interface (PreDriver)**

Terminal name	Function
ISENADIN	PreDriver voltage output
TOINF	Motor control signal input ( $W_n$ )
TOINE	Motor control signal input ( $V_n$ )
TOINC	Motor control signal input ( $W_p$ )
TOINB	Motor control signal input ( $V_p$ )
TOIND	Motor control signal input ( $U_n$ )
TOINA	Motor control signal input ( $U_p$ )
ALARM	ALARM signal output
HIC_W	W phase hall IC signal output
HIC_V	V phase hall IC signal output
HIC_U	U phase hall IC signal output
SI	Data input for SPI control
SO	Data output for SPI control
SCLK	Clock input for SPI control
CS	Chip select input for SPI control
CLK	System clock input
LD, TOINH, TOING	Unused terminal
VM	Power Supply
UHOUT	U phase High-Side Driver (Nch) driving output
U	For U phase detection
ULOUT	U phase Low-Side Driver (Nch) driving output
VHOUT	V phase High-Side Driver (Nch) driving output
V	For V phase detection
VLOUT	V phase Low-Side Driver (Nch) driving output
WHOUT	W phase High-Side Driver (Nch) driving output
W	For W phase detection
WLOUT	W phase Low-Side Driver (Nch) driving output
ISENP	Shunt resistance Plus side connection
ISENN	Shunt resistance Minus side connection
DrvGND	PreDriver output stage circuit GND
VREG5	Regulator Output (5V)
UH	U phase hall IC signal input
VH	V phase hall IC signal input
WH	W phase hall IC signal input
AGND	PreDriver analog circuit GND

### 2.2.2 Peripheral functions

List of peripheral functions used in this system is shown in Table 2-4.

**Table 2-4 Peripheral Functions List**

Peripheral function	Usage
A/D converter	Rotation speed command value input (analog value)
	Voltage measurement (PreDriver voltage measurement/VM voltage measurement)
	Option: temperature measurement
General-purpose port	For rotation direction command value input (CW/CCW)
	Hall IC signal input (position detection)
	Motor control signal output: port output
	LED output ON/OFF control
	Option: LED right output, toggle switch input / push switch input
Timer Array Unit	500[us] interval timer
	Free run timer for rotation speed measurement
Timer RJ	System clock output for PreDriver
Timer RD	Motor control signal output: PWM output using complimentary PWM mode (six outputs)
External interruption	ALARM signal detection
	Hall IC signal detection (Both edges)
Communication interface	SPI00 (for PreDriver control)
	UART1 (for ICS)
	option: SPI01, IICA0

#### (1) A/D converter

The rotation speed command value input (Analog value) and voltage are measured by using 'A/D converter'.

A/D conversion is set channel selection mode to 'Select mode' and conversion operation mode to 'One shot conversion mode' (use software trigger).

Conversion speed of the A/D converter is 2.375[us] per channel and the smallest unit of conversion input value is shown in Table 2-5.

**Table 2-5 A/D converter**

Item	Control value for A/D converter 1 bit	Channel
Rotation speed command input (analog value)	5.56[rpm] step (rotation speed range is 1100[rpm] to 4290[rpm] for both CW/CCW)	ANI6
Voltage measurement	VM voltage measurement: 45.9[V] / 1024 = 0.045[V]	ANI3
	PreDriver voltage <sup>Note 3</sup> measurement: 48.0[V] / 1024 = 0.047[V]	ANI7

Note:

- The PreDriver voltage switches a signal converting A/D by setting of register (ADC\_SEL) for ADC selectors of the PreDriver side and can measure it.  
The control value of when 0x00 (VM voltage detection) was set to ADC\_SEL is reflected.  
Please refer to "RAJ306000 Series User's Manual: Hardware (R18UZ0066EJ0100)" about the details.

## (2) General-purpose port

Hall IC signal (Magnetic position detection signals of the motor) are input to a general-purpose port. As edge detection of the position signal is also necessary for hall IC, a dual port used with external interruption is used. Combination of hall IC signal input and general-purpose ports in this system is shown in Table 2-6.

**Table 2-6 General-purpose port and hall IC signal input**

Terminal name	Hall IC signal
P52/INTP1	U phase
P53/INTP2	V phase
P54/INTP3	W phase

Also, this system output a motor control signal along with the PWM output using the port output function. Combination of Motor control signal output and general-purpose ports are shown in Table 2-7.

**Table 2-7 General-purpose port and motor control signal output**

Terminal name	Motor control signal
P10/TRDIOD1	$W_n$
P11/TRDIOC1	$V_n$
P12/TRDIOB1	$W_p$
P13/TRDIOA1	$V_p$
P14/TRDIOD0	$U_n$
P15/TRDIOB0	$U_p$

## Note:

Please refer to "RL78/G1F User's Manual: Hardware (R01UH0516EJ0110)" about the notes when switching a general-purpose port from input mode to output mode,

## (3) Timer Array Unit

- 500[us] interval timer

500[us] interval timer uses 'Interval timer function' of Timer Array Unit. In this system, channel 0 is used.

- Free-run timer for rotation speed measurement

Free-run timer for rotation speed measurement uses 'Interval timer function' of Timer Array Unit. However, it does not use the interruption. In this system, channel 1 is used.

Also, in this system, channel 2 and channel 3 are not used.

## (4) Timer RJ

Using the pulse output mode, it outputs a 4 MHz square wave and supplies it as System clock for PreDriver.

## (5) Timer RD

Using the Complementary PWM mode, it output (6-wire) a three-phase PWM with a triangle wave modulation and a short circuit preventive time.

In this system, support the PWM output of High active. (PWM frequency is 50[us]) In case of detect the ALARM (At the time of Input of Low signal to INTP4 port), PreDriver output signal will be change to Hi-Z (Output terminal value for Motor control signal becomes set to Low)

The combination of timer output and motor control signal are shown in Table 2-8.

**Table 2-8 timer output terminal and motor control signal output**

Terminal name	Motor control signal
P10/TRDIOD1	$W_n$
P11/TRDIOC1	$V_n$
P12/TRDIOB1	$W_p$
P13/TRDIOA1	$V_p$
P14/TRDIOD0	$U_n$
P15/TRDIOB0	$U_p$

## (6) Interruption

List of interruptions in this system is shown in Table 2-9.

**Table 2-9 Interruption**

Interruption name	Interruption source
P55/INTP4	ALARM signal detection
P54/INTP3	W phase hall IC signal detection (Both edges)
P53/INTP2	V phase hall IC signal detection (Both edges)
P52/INTP1	U phase hall IC signal detection (Both edges)
INTTM00	500[us] interval timer
INTTRD0	Carrier frequency (PWM)
INTCSI00	Complete of SPI00 communication for PreDriver control

## 2.3 Software structure

### 2.3.1 Software file structure

Folders and files structure of the sample program is shown in Table 2-10 and Table 2-11.

**Table 2-10 Folder and Files Structure of Sample Program (1)**

RAJ306000_HALL_120_OPEN_CSP_CA_V107		
RAJ306000_HALL_120_OPEN_CSP_CC_V107		
RAJ306000_HALL_120_OPEN_E2S_CC_V107		
Inc	control_parameter.h	Header for control characteristic dependent processing part
	motor_parameter.h	Header for motor characteristic dependent processing part
	mtr_common.h	Header for Common definition
	mtr_ctrl_rl78g1f.h	Header for RL78/G1F dependent processing part
	mtr_ctrl_rl78g1f_t2001.h	Header for RL78/G1F & Board dependent processing part
	mtr_ctrl_t2001.h	Header for Board dependent processing part
	mtr_main.h	Main function, Header for user interface control
	mtr_spm_hall_120_cpm.h	Header of 120-degrees conducting control (using hall IC) dependent part
	r_dsp.h	Header for operation library
	r_stdint.h	Header for operation library
	version.h	Header of software revision
ics	ICS2_CA_RL78G1F.lib	Library for ICS (for CA78K0R) (Note 4)
	ICS2_CC_RL78G1F.lib	Library for ICS (for CC-RL) (Note 5)
	ics2_RL78G1F.h	Header for ICS
	RL78_vector.c	Interrupt handler for ICS
	RL78_vector.h	Interrupt handler header for ICS
lib	R_dsp_rl78_CA.lib	Library for operation (for CA78K0R) (Note 4)
	R_dsp_rl78_CC.lib	Library for operation (for CC-RL) (Note 5)
src	mtr_ctrl_rl78g1f.c	RL78/G1F dependent processing part
	mtr_ctrl_rl78g1f_t2001.c	RL78/G1F & Board dependent processing part
	mtr_ctrl_t2001.c	Board dependent processing part
	mtr_interrupt.c	Interrupt handler
	mtr_main.c	Main function, user interface control
	mtr_spm_hall_120_cpm.c	120-degrees conducting control (using hall IC) dependent part

Note:

4. "For CA78K0R" is included only in RAJ306000\_HALL\_120\_OPEN\_CSP\_CA\_V107.
5. "For CC-RL" is included only in RAJ306000\_HALL\_120\_OPEN\_CSP\_CC\_V107 and RAJ306000\_HALL\_120\_OPEN\_E2S\_CC\_V107.

Table 2-11 Folder and Files Structure of Sample Program (2)

RAJ306000_HALL_120_OPEN_CSP_CA_V107		
RAJ306000_HALL_120_OPEN_CSP_CC_V107		
RAJ306000_HALL_120_OPEN_E2S_CC_V107		
cg_src	r_cg_adc.c	RL78/G1F ADC processing
	r_cg_adc.h	RL78/G1F header of ADC processing
	r_cg_adc_user.c	RL78/G1F ADC processing (for User)
	r_cg_cgc.c	RL78/G1F clock output processing
	r_cg_cgc.h	Header for RL78/G1F clock output processing
	r_cg_cgc_user.c	RL78/G1F clock output processing (for User)
	r_cg_intp.c	RL78/G1F interrupt function processing
	r_cg_intp.h	Header for RL78/G1F interrupt function processing
	r_cg_intp_user.c	RL78/G1F interrupt function processing (for User)
	r_cg_macrodriver.h	Header for RL78/G1F Error definition
	r_cg_main.c	RL78/G1F main processing
	r_cg_main.h	Header for RL78/G1F main processing
	r_cg_port.c	RL78/G1F port function processing
	r_cg_port.h	Header for RL78/G1F port function processing
	r_cg_port_user.c	RL78/G1F port function processing (for User)
	r_cg_predrv.c	PreDriver processing
	r_cg_predrv.h	Header for PreDriver processing
	r_cg_predrv_prm.h	Header for PreDriver register parameter definition
	r_cg_predrv_reg.h	Header for PreDriver register address definition
	r_cg_predrv_user.c	PreDriver processing (for User)
	r_cg_sau.c	RL78/G1F Serial array unit processing
	r_cg_sau.h	Header for RL78/G1F Serial array unit processing
	r_cg_sau_user.c	RL78/G1F serial array unit processing (for User)
	r_cg_systeminit.c	RL78/G1F initial processing
	r_cg_tau.c	RL78/G1F timer array unit processing
	r_cg_tau.h	Header for RL78/G1F timer array unit processing
	r_cg_tau_user.c	RL78/G1F timer array unit processing (for User)
	r_cg_tmrd.c	RL78/G1F timer RD processing
	r_cg_tmrd.h	Header for RL78/G1F timer RD processing
	r_cg_tmrd_user.c	RL78/G1F timer RD processing (for User)
	r_cg_tmrv.c	RL78/G1F timer RJ processing
	r_cg_tmrv.h	Header for RL78/G1F timer RJ processing
	r_cg_tmrv_user.c	RL78/G1F timer RJ processing (for User)
	r_cg_userdefine.h	Header for RL78/G1F user definition
r_cg_wdt.c	RL78/G1F watch dog timer processing	
r_cg_wdt.h	Header for RL78/G1F watch dog timer processing	
r_cg_wdt_user.c	RL78/G1F watch dog timer processing (for User)	

2.3.2 Module structure

Module structure of the sample program is described on Figure 2-4.

The relationship between module and file are shown in Table 2-12.

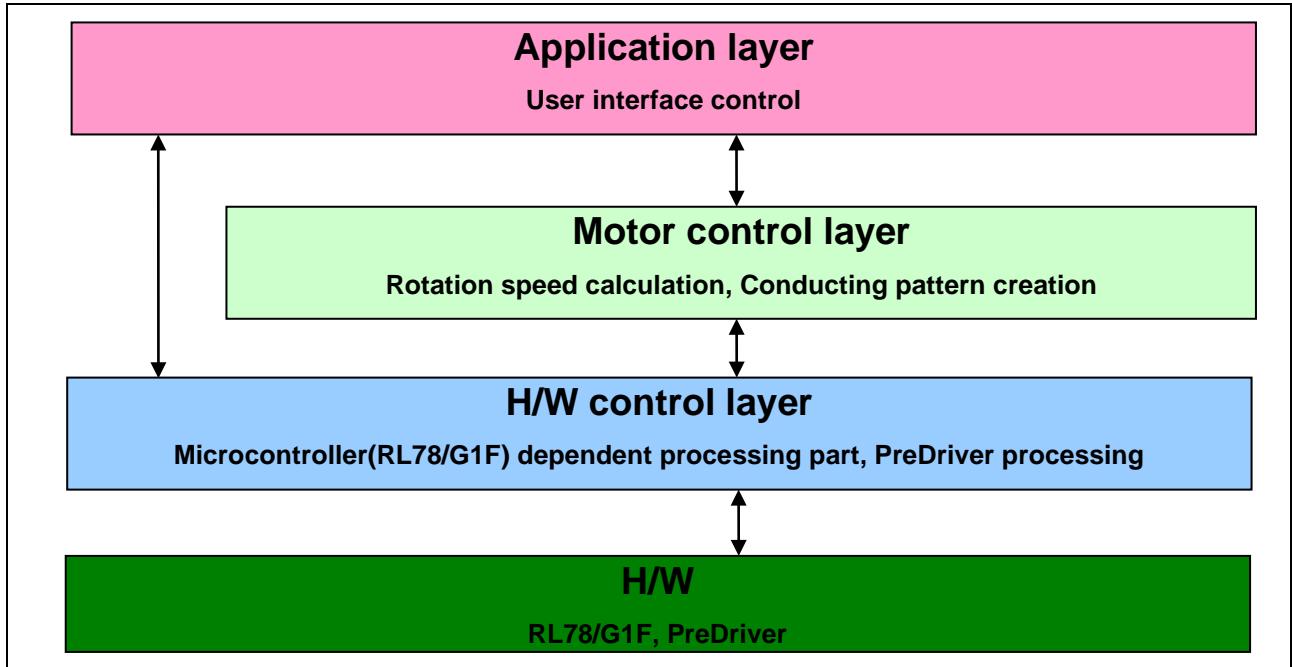

Figure 2-4 Hierarchical Structure of Sample Program

Table 2-12 Hierarchical structure of Sample Program

<b>Application layer</b>	mtr_main.c
<b>Motor control layer</b>	mtr_interrupt.c, mtr_spm_hall_120_cpm.c
<b>H/W control layer</b>	mtr_ctrl_rl78g1f.c, mtr_ctrl_rl78g1f_t2001.c, mtr_ctrl_t2001.c, r_cg_adc.c, r_cg_adc_user.c, r_cg_cg.c, r_cg_cg_user.c, r_cg_intp.c, r_cg_intp_user.c, r_cg_main.c, r_cg_port.c, r_cg_port_user.c, r_cg_predrv.c, r_cg_predrv_user.c, r_cg_sau.c, r_cg_sau_user.c, r_cg_systeminit.c, r_cg_tau.c, r_cg_tau_user.c, r_cg_tmrd.c, r_cg_tmrd_user.c, r_cg_tmrj.c, r_cg_tmrj_user.c, r_cg_wdt.c, r_cg_wdt_user.c



### 2.4 Software specifications

Basic specifications of software of this system are shown in Table 2-13 and Figure 2-5.

**Table 2-13 Software Basic Specifications**

Item	Content
Control method	120-degrees conducting method
Motor rotation start/stop	Motor start/stop control is determined depending on the level of VR1(AIN6 terminal). Input from ICS (Note 6)
Rotation direction control	Rotation direction command value (CW/CCW) control is determined depending on the level of SW1 (P122 terminal). Input from ICS (Note 6)
Rotation Speed control	Rotation speed command value is determined from input voltage of VR1 (AIN6 terminal). Control the PWM duty proportional to the rotation speed command value with 0 to 100[%]
Rotation speed control range	1100[rpm] to 4290[rpm] for both CW/CCW
Position detection of rotor magnetic pole	Every interrupt by hall IC signal detection (Both edges) (Every 60 degrees)
Carrier frequency (PWM)	20[KHz]
Control cycle/Rotation speed operation	Every interrupt by hall IC signal detection (Both edges) (Every 60 degrees) <ul style="list-style-type: none"> <li>• Determination of PWM duty setting and Conducting pattern</li> <li>• Calculate rotation speed from the difference value with the counter level of before 1 rotation (360 degrees)</li> </ul>
Processing stop for protection	Output terminal of Motor control signal is set to Low state at the time of detect the below errors. <ul style="list-style-type: none"> <li>• ALARM error</li> <li>• Over voltage error</li> <li>• Rotation speed abnormal error</li> <li>• Timeout error</li> <li>• Hall IC signal pattern error</li> <li>• Under voltage error</li> </ul>

Note:

6. Please refer to the "4 Development support tool In Circuit Scope" about details.

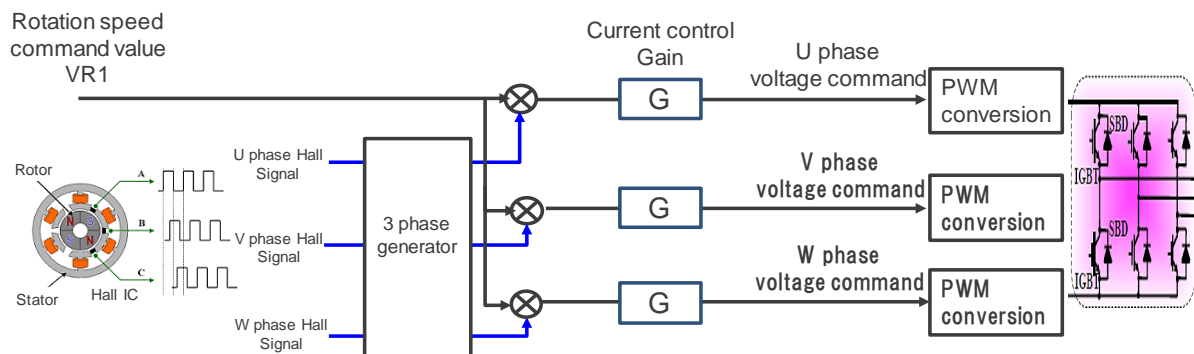

**Figure 2-5 Basic specification of Software**

### 3. Descriptions of control program

The target sample programs of this application note are explained here.

#### 3.1 Contents of control

##### 3.1.1 Motor start / stop

Starting and stopping of the motor are controlled by input from VR1 and SW1. An analog input port (ANI6) is assigned to VR1. The input is A/D converted within the main loop to calculate Rotation speed command value. Program is judged that Motor was started at the time of the command value is more than 1200[rpm]. And Program is judged the motor was stopped at the time of the command value is less than 1100[rpm]. Additional, Startup of motor is judged it along with Motor lock status of PreDriver.

General-purpose port (P122 terminal) is assigned to SW1 and, in main loop, acquires a High/Low state of the P122 terminal and assumes it a rotation direction command value. The rotation direction is judged from a rotation direction command value.

##### 3.1.2 Rotation direction command value, Rotation speed command value, VM voltage.

###### (1) Rotation direction command value

Rotation direction command value can be set by high/low state of SW1 or input information from ICS.

###### (2) Rotation speed command value

Rotation speed command value can be set by A/D conversion of the VR1 output value (Analog value). Set VR1 output value converted A/D to the rotation speed command value.

VR1 value that A/D converted is used to Rotation speed command value as shown below (Table 3-1).

**Table 3-1 Conversion Ratio of the Rotation Speed Command Value**

Item	Conversion ratio (Command value: A/D conversion value)	Channel
Rotation speed command value	1100[rpm] to 4290[rpm]: 03FFH to 0000H	ANI6

###### (3) VM voltage

It is used for detection of over voltage and under voltage. (When an abnormality is detected, PWM is stopped.) Conversion ratio of VM voltage value is shown in Table 3-2.

**Table 3-2 Conversion Ratio of VM Voltage**

Item	Conversion ratio (VM voltage: A/D conversion value)	Channel
VM voltage	0.0[V] to 45.9[V]: 0000H to 03FFH	ANI3

### 3.1.3 Rotation speed calculation

Acquire counter data at the time of the outside interrupt outbreak from hall IC signal by Free-running operation of channel 1 in the timer array unit, and calculates the rotation speed from the difference data of before 1 rotation (360 degrees) of the motor. Additional, Processing of LPF (low-pass filter) is carried out about this calculation result data. Calculation Method (Conceptual diagram) of rotation speed is shown in Figure 3-1.

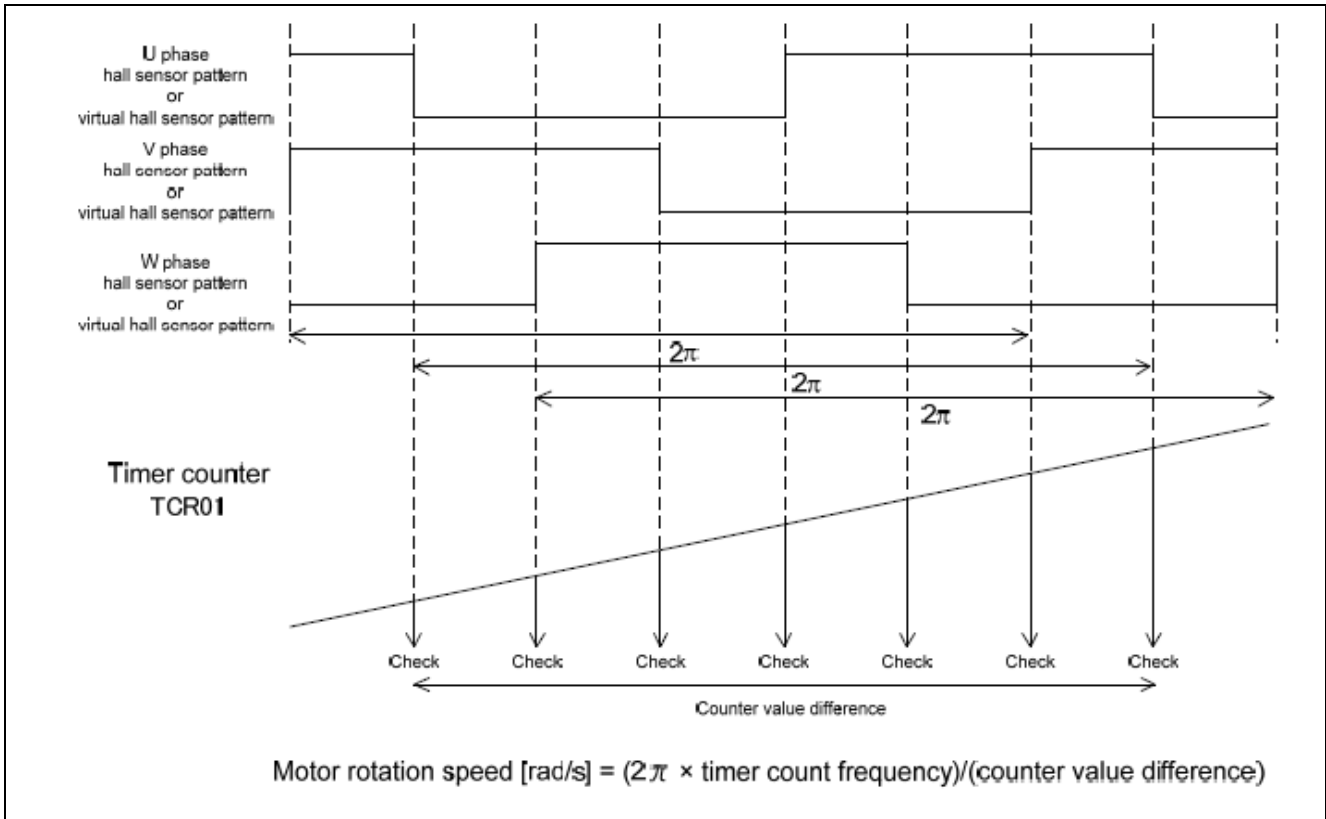

Figure 3-1 Rotation Speed Calculation Method

3.1.4 Voltage control by PWM

PWM control is used for the output voltage control. The PWM control is a control method that continually adjusts the average voltage by varying the duty of pulse, and PWM control is controlled by value that PWM duty value is proportional to Rotation speed command value. Conception diagram of the PWM control is shown Figure 3-2.

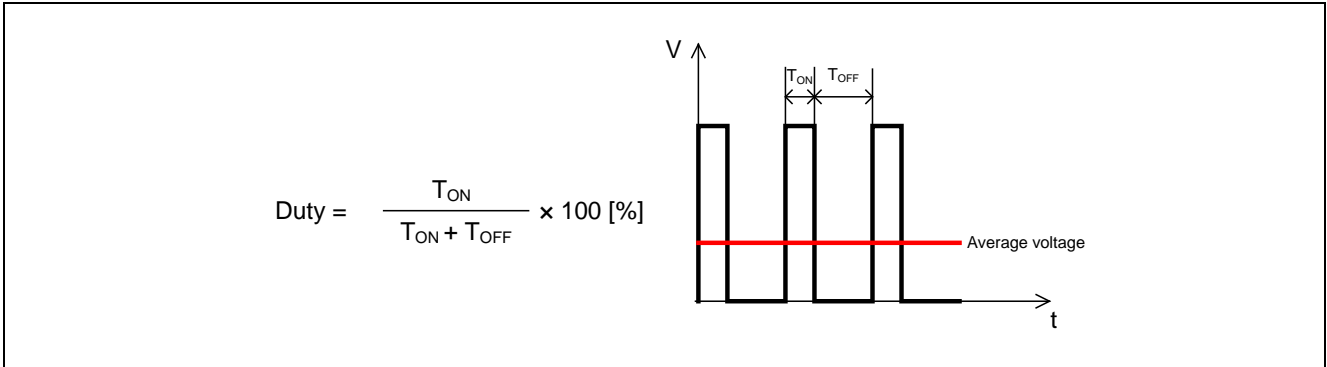

Figure 3-2 PWM control

Chopping control is adopted at the first 60 degrees in this system and output voltage and speed are controlled. An example of motor control signal output waveforms at the time of complementary first 60 degrees chopping is shown in Figure 3-3.

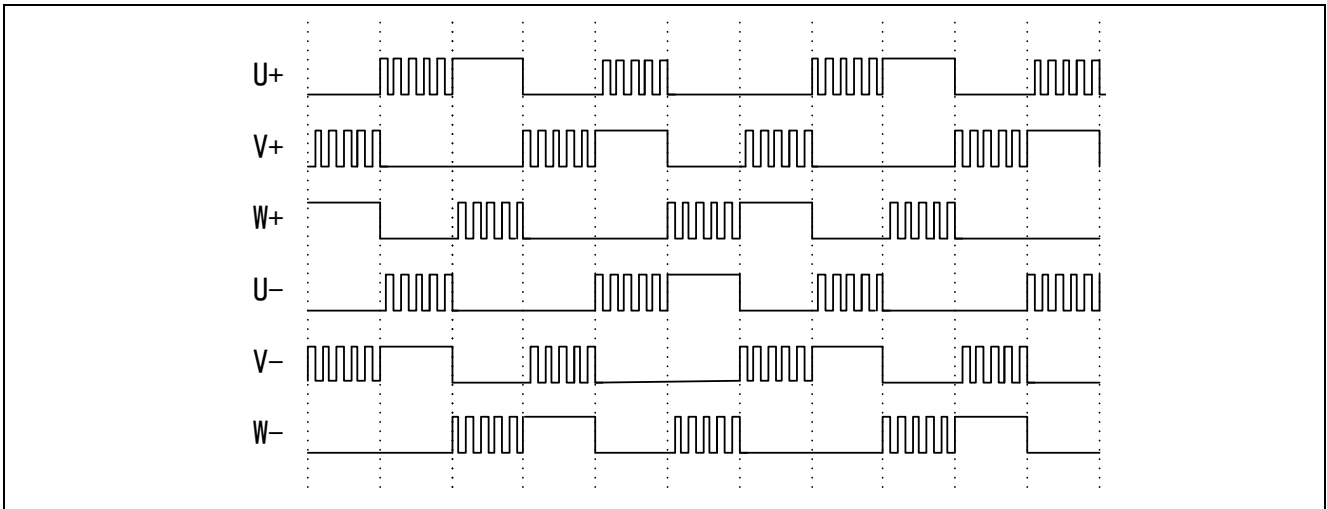

Figure 3-3 Complimentary first 60 degrees chopping

3.1.5 State transition

State transition diagrams of the sample programs are shown in Figure 3-4.

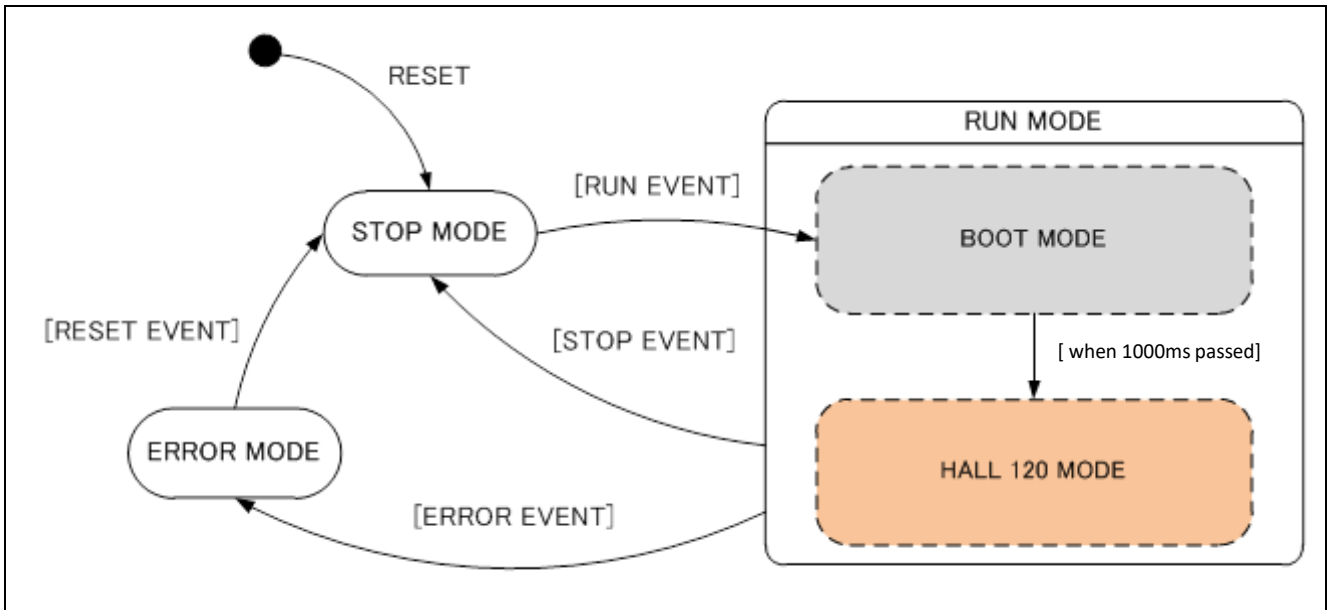

Figure 3-4 State Transition Diagram

### 3.1.6 System protection function

This system has below error condition. Emergency stop function is operate as each condition of the following. Each set value related to the system protection function is shown in Table 3-3.

- ALARM error

Emergency stop is performed by setting the output of PreDriver to the high impedance state (Output terminal signal for motor control is Low state) by the emergency stop signal (ALARM detection) from PreDriver.

- Over voltage error

When an over voltage is detected (when the voltage exceeds the limit value) in VM voltage on a cycle of over voltage detection, System is performed an emergency stop.

- Rotation speed abnormality error

When the rotation speed exceeded the limit value on a cycle of the rotation speed detect operation, System is performed an emergency stop.

- Timeout error

When a pattern of an interval by an external interrupt from hall IC is not switch for over Timeout limit value in Timeout error detection, System is performed an emergency stop.

- Hall IC signal pattern error

When Error pattern on a pattern of hall IC of every external interrupt is detected in hall IC signal pattern error detect operation, System is performed an emergency stop.

- Under voltage error

When an under voltage is detected (when the voltage less than the limit value) in VM voltage on a cycle of under voltage detection, System is performed an emergency stop.

**Table 3-3 Setting value for Protect function of each system**

Error Condition		Setting value
Over voltage error	Over voltage limit value	30[V]
	Monitoring interval	50[us]
Rotation speed abnormality error	Rotation speed limit value	4290[rpm]
	Monitoring interval	50[us]
Timeout error	Timeout setting	20[ms]
Under voltage error	Under voltage limit value	6[V]
	Monitoring interval	50[us]

### 3.1.7 System protect function (PreDriver safety function)

The PreDriver safety function can be enabled / disabled with the ALARM operation setting register (ALMOPE).

Please refer to the data sheet about details.

### 3.2 Function specifications

Lists of control functions are shown in Table 3-4 and Table 3-5.

**Table 3-4 List of Control Functions (1)**

File name	Function overview	Processing overview
mtr_main.c	main() input: none output: none	<ul style="list-style-type: none"> <li>• Hardware initialization function call</li> <li>• User interface initialization function call</li> <li>• Main function use variable initialization function call</li> <li>• Status transition and event execution function call</li> <li>• Main function</li> <li>- Main processing execution function call</li> <li>- Watchdog timer clear function call</li> </ul>
	ctrl_ui() input: none output: none	<ul style="list-style-type: none"> <li>• Change Motor status</li> <li>• Determination of rotation speed command value and rotation direction command value</li> </ul>
	ics_ui() input: none output: none	<ul style="list-style-type: none"> <li>• Change Motor status</li> <li>• Determination of rotation speed command value and rotation direction command value</li> </ul>
	ctrl_led() input: none output: none	Control the output pattern of ON/OFF for LED
	ics_predrv_reg_ctrl() input: none output: none	Control for PreDriver register read/write from ICS
	mcu_sw_init() input: none output: none	Initialization of F/W <ul style="list-style-type: none"> <li>• initialization of F/W variables</li> <li>• initialization of ICS</li> <li>• initialization of sequence processing</li> <li>• execution of RESET event</li> </ul>
	software_init() input: none output: none	Initialization of variables used in the main function
mtr_ctrl_rl78g1f.c	clear_wdt() input: none output: none	Clear Flag for the watchdog timer
	mtr_clear_oc_flag() input: none output: none	Clear Flag for the pulse output forced shutdown
	mtr_clear_trd0_imfa() input: none output: none	Clear Flag for the TRD0 compare match (IMFA)

mtr_ctrl_rl78g1f_t2001.c	mtr_ctrl_start() input: none output: none	Motor startup processing
	mtr_ctrl_stop() input: none output: none	Motor stop processing
	mtr_change_pattern() input: Conduction pattern output: none	Change the motor control signal output <ul style="list-style-type: none"> <li>• Setting a conducting pattern</li> <li>• Changing the motor status when a conducting pattern error occurs</li> <li>• Event processing selection function call</li> </ul>
	mtr_get_adc() input: A/D channel output: A/D conversion result	Processing execution of the A/D convert
mtr_ctrl_t2001.c	get_vr1() input: none output: A/D conversion result of VR1	Obtain of the A/D conversion value of the trigger level
	led_on() input: LED channel number output: none	Turning LED ON
	led_off() input: LED channel number output: none	Turning LED OFF
mtr_interrupt.c	mtr_hall_interrupt() input: none output: none	Hall IC signal interrupt processing <ul style="list-style-type: none"> <li>• Conducting pattern determination function call</li> </ul>
	mtr_alarm_interrupt() input: none output: none	ALARM interrupt processing <ul style="list-style-type: none"> <li>• Change motor status</li> <li>• Function call for selection of an event processing</li> <li>• Function call for clear of flag of a forced interception of the pulse output</li> </ul>
	mtr_tau0_interrupt() input: none output: none	500[us] interrupt processing <ul style="list-style-type: none"> <li>• Operation mode switching determination processing</li> </ul>
	mtr_carrier_interrupt() input: none output: none	Carrier frequency interrupt processing <ul style="list-style-type: none"> <li>• Waiting for motor rotation stop</li> <li>• Error check function call</li> </ul>



mtr_spm_hall_120_cpm.c	R_MTR_InitSequence() input: none output: none	Initialization of sequence processing
	R_MTR_ExecEvent() input: occurred event output: none	<ul style="list-style-type: none"> <li>• Execute to change the status.</li> <li>• Call execution function of suitable processing for the event.</li> </ul>
	Mtr_act_run() input: motor status output: motor status	<ul style="list-style-type: none"> <li>• Variable initialization function call upon motor startup</li> <li>• Motor control startup function call</li> <li>• Conducting pattern determination function call</li> </ul>
	mtr_act_stop() input: motor status output: motor status	Motor control stop function call
	mtr_act_none() input: motor status output: motor status	No processing is performed.
	Mtr_act_reset() input: motor status output: motor status	Initialization of Global variable for return from Error state.
	Mtr_act_error() input: motor status output: motor status	Motor control stop function call at the time of Error occur.
	Mtr_pattern_set() input: none output: none	<ul style="list-style-type: none"> <li>• Rotation speed measurement function call</li> <li>• Obtaining the hall IC signal pattern</li> <li>• Determine of Conducting pattern</li> <li>• Motor control signal output change function call</li> </ul>
	mtr_speed_calc() input: none output: none	Processing of calculation for rotation speed measurement
	mtr_start_init() input: none output: none	Initializing only the variables required at the time of motor startup
	mtr_set_variables() input: none output: none	Set Input data at ICS to Protecting variable.
	R_MTR_IcsInput() input: structure of ICS variables output: none	Obtaining of variable that inputted from the ICS.
	R_MTR_SetSpeed() input: rotation speed command value output: none	Rotation speed setting
	R_MTR_SetDir() input: rotation direction command value output: none	Rotation direction setting
	R_MTR_GetSpeed() input: none output: rotation speed information	Obtaining the rotation speed
	R_MTR_GetDir() input: none output: rotation direction information	Obtaining the rotation direction.
	R_MTR_GetStatus() input: none output: motor status	Obtaining the motor status
mtr_error_check() input: none output: none	Monitoring and Detection of Error	

Table 3-5 List of Control functions (2)

File name	Function overview	Processing overview
r_cg_adc.c	R_ADC_Create() input: none output: none	Initialization of A/D converter
r_cg_adc_user.c	r_adc_interrupt() input: none output: none	SPI communication ADC mode SPI start judgement
r_cg_cgc.c	R_CGC_Create() input: none output: none	Initialization of clock frequency (CGC)
r_cg_intp.c	R_INTP_Create() input: none output: none	Initialization of external interrupt (INTP)
r_cg_main.c	R_MAIN_UserInit() input: none output: none	PreDriver startup processing
r_cg_port.c	R_PORT_Create() input: none output: none	Initialization of I/O port setting
r_cg_predrv.c	predriver_hw_init() input: none output: none	PreDriver initialization setting
	R_PREDRV_TRIM_Create() input: none output: SPI status	PreDriver trimming data setting
	R_PREDRV_InitSequence() input: none output: none	PreDriver initialization processing
	R_PREDRV_ErrorRecoverySequence() input: ALARM status output: none	ALARM recovery processing
r_cg_predrv_user.c	R_PreDrvReg_Read() input: read address output: SPI status, read data	Read processing to PreDriver register
	R_PreDrvReg_Write() input: write address, write data output: SPI status	Write processing to PreDriver register
	R_PreDrv_MotorLockStatus() input: none output: motor lock status	Processing for obtain of Motor lock status

r_cg_sau.c	R_SAU0_Create() input: none output: none	Initialization of serial array unit (SAU)
	R_UART1_Create() input: none output: none	Initialization of UART1
	R_CSI00_Create() input: none output: none	Initialization of SPI communication (for PreDriver communication)
	R_CSI00_Start() input: none output: none	Startup SPI communication (for PreDriver communication)
	R_CSI00_Send_Receive_SPI_mode() input: tx buffer buffer size rx buffer SPI mode output: SPI status	SPI communication processing
r_cg_sau_user.c	r_csi00_interrupt() input: none output: none	SPI interrupt processing (for PreDriver communication)
r_cg_systeminit.c	hdwinit() input: none output: none	Initial setting of H/W
r_cg_tau.c	R_TAU0_Create() input: none output: none	Initialization of TAU
r_cg_tmr.c	R_TMRD0_Create() input: none output: none	Initialization of Timer RD (TRD)
	R_TMRD0_Start() input: none output: none	PWM output start
r_cg_tmrj.c	R_TMRJ0_Create() input: none output: none	Initialization of Timer RJ (TRJ)
	R_TMRJ0_Start() input: none output: none	Start supply a clock for PreDriver
r_cg_wdt.c	R_WDT_Create() input: none output: none	Initialization of Watch dog timer

### 3.3 Specification of variables

Lists of variables for the sample program are shown in Table 3-6.

**Table 3-6 List of Variables**

Variable name	Type	Content	Remarks
g_s2_max_speed	int16_t	Rotation speed command maximum value	Mechanical angle [rpm]
g_s2_min_speed	int16_t	Rotation speed command minimum value	Mechanical angle [rpm]
g_s2_margin_min_speed	int16_t	Rotation speed command minimum value for motor stop	Mechanical angle [rpm]
g_s2_ref_speed	int16_t	Setting of rotation speed by user	Mechanical angle [rpm]
g_u2_speed_rpm	uint16_t	Rotation speed calculation value	Mechanical angle [rpm]
g_u1_rot_dir	uint8_t	Setting of rotation direction by user	0: CW 1: CCW
g_u1_motor_status	uint8_t	Management of motor status by user	0: Stop 1: Rotating 2: Error
g_u1_motorlock_status	uint8_t	Management of Motor lock status	0: motor lock 1: motor unlock
g_u1_stop_req	uint8_t	Motor stop command flag	Stop is determined when the rotation speed command value is less than 1100[rpm]
g_u1_pdrv_status	uint8_t	Register Read/Write for PreDriver Error status	-
g_u1_err_recovery_req	uint8_t	ALARM recovery processing request flag	0: Disable 1: Enable
g_u1_get_alarm_sts1	uint8_t	PreDriver register ALMSTS1 acquired value	-
g_u1_store_alarm_sts1	uint8_t	PreDriver register ALMSTS1 stored value	-
g_u1_get_alarm_sts2	uint8_t	PreDriver register ALMSTS2 acquired value	-
g_u1_store_alarm_sts2	uint8_t	PreDriver register ALMSTS2 stored value	-
g_u2_fw_revision	uint16_t	F/W Revision information	F/W Version information (107)
g_s2_sw_userif	int16_t	Flag for switch of Board UI	0: not use Board UI 1: use Board UI
g_s2_mode_system	int16_t	Flag for system mode	0: Stop 1: Motor startup 2: Error 3: Reset
g_s2_enable_write	int16_t	Flag for Write enable of ICS	Toggle operate
ics_input	MTR_ICS_INPUT	Structure for input of ICS	-
g_u2_cnt_boot_mode	uint16_t	Counter for time measurement of Boot mode	500[us] after motor startup is counted.
G_u2_cnt_wait_stop	uint16_t	Motor rotation stop waiting counter	10[ms] after motor stop processing is counted. (Note that the count is reset when a hall IC signal interrupt is detected.)
g_u1_flg_wait_stop	uint8_t	Flag for waiting time of Motor rotation stop	The flag set upon motor stop command. When no hall IC signal interrupt is detected for 10[ms] after motor stop processing, the flag is cleared.
G_u1_enable_write	uint8_t	Flag for Write enable of Structure for ICS input.	0: Disable 1: Enable
g_s2_vdc_ad	int16_t	A/D value of VM voltage	[V]
g_s2_reci_vdc_ad	int16_t	Inverse of A/D value from VM voltage	-
g_s2_pdrv_ad	int16_t	A/D value of PreDriver voltage	[V]
g_s2_pwm_duty	int16_t	Setting value of Timer RD compare register	PWM Duty setting value: 0 to 1598 PWM Duty [%]: 0 to 100

g_s2_ref_speed_rad	int16_t	Rotation speed command value	Electrical angle (Scale: Q2) [rad/s]
g_s2_speed_rad	int16_t	Rotation speed calculation value	Electrical angle (Scale: Q2) [rad/s]
g_s2_speed_lpf_k	int16_t	Rotation speed LPF parameter	-
g_u1_cnt_ics	uint8_t	Counter for interval of ICS function call	-
g_u2_run_mode	uint16_t	Operation mode management	0: Boot mode 3: Normal operation (HALL 120) mode
g_u1_error_status	uint8_t	Error status management	0x01: ALARM error 0x02: Over voltage error 0x04: Rotation speed abnormality error 0x08: Timeout error 0x10: Hall IC signal pattern error 0x40: Under voltage error (0x80: Undefined error)
g_u1_mode_system	uint8_t	Management of system mode	0: Stop, 1: Run, 2: Error
g_u1_hall_signal	uint8_t	Three-phase hall IC signal pattern	-
g_u1_v_pattern	uint8_t	Conducting pattern	-
g_u2_cnt_timeout	uint16_t	Stop determination time measurement counter	Cleared when the conducting pattern is switched.
G_u1_direction	uint8_t	Rotation direction management	0: CW 1: CCW
g_u2_hall_timer_cnt	uint16_t	Free run timer count value	TCR01
g_u2_pre_hall_timer_cnt	uint16_t	Previous of free run timer count value	-
g_s2_timer_cnt_ave	int16_t	Rotation speed measurement timer count difference for 2 Pi	-
g_u2_timer_cnt_buf	uint16_t	Buffer of a timer count for measurement of Rotation speed	-
g_u2_timer_cnt_num	uint16_t	Buffer numbers of a timer count for measurement of Rotation speed	-
ics_input_buff	MTR_ICS_INPUT	ICS input variable structure	-
g_s2_ref_speed_rpm_vr1	int16_t	Rotation speed command value	Mechanical angle [rpm]
g_u1_alarm_sts1	uint8_t	PreDriver register ALMSTS1 stored value	For ICS display
g_u1_alarm_sts2	uint8_t	PreDriver register ALMSTS2 stored value	For ICS display
g_u1_PreDriver_error	uint8_t	PreDriver sequence error status	• PreDriver initial sequence • ALARM recovery sequence
g_spi00_comend_flag	uint8_t	SPI communication condition flag	TURE: communication end FALSE: connecting
g_spi00_adcend_flag	uint8_t	SPI communication ADC End flag	TURE: ADC end FALSE: ADC executing
g_spi00_commode	uint8_t	SPI communication mode	-
gp_csi00_rx_address	uint8_t	SPI communication receives data address	Obtain of PreDriver register value
g_csi00_rx_length	uint16_t	SPI communication receives data length	-
g_csi00_rx_count	uint16_t	SPI communication receives counter	-
gp_csi00_tx_address	uint8_t	SPI communication transmission data address	Designation of PreDriver register address
g_csi00_send_length	uint16_t	SPI communication transmission data length	-
g_csi00_tx_count	uint16_t	SPI communication transmission counter	-

### 3.4 Specification of Macro definition

Lists of macro definitions used in this sample program are shown in Table 3-7

Table 3-7 List of Macro Definitions

File name	Macro name	Definition value	Remarks
control_parameter.h	CP_MAX_SPEED_RPM	3900	Rotation speed command maximum value (mechanical angle) [rpm]
	CP_MIN_SPEED_RPM	1200	Rotation speed command minimum value (mechanical angle) [rpm]
	CP_SPEED_LPF_K	0.35f	LPF parameter for Rotation speed.
Mtr_main.h	ICS_UI	0	Set UI to ICS
	BOARD_UI	1	Set UI to Board
	M_CW	0	User setting rotation direction: CW
	M_CCW	1	User setting rotation direction: CCW
	MAX_SPEED	CP_MAX_SPEED_RPM	Rotation speed command maximum value (mechanical angle) [rpm]
	MIN_SPEED	CP_MIN_SPEED_RPM	Rotation speed command minimum value (mechanical angle) [rpm]
	MARGIN_SPEED	100	Rotation speed command minimum value creation constants for motor stop (mechanical angle) [rpm]
	MARGIN_MIN_SPEED	MIN_SPEED MARGIN_SPEED	Rotation speed command minimum value for motor stop (mechanical angle) [rpm]
	SPEED_LPF_K	CP_SPEED_LPF_K 16384	* LPF parameter value for Rotation speed
	SW_ON	0	Active in case of Low
	SW_OFF	1	Active in case of High
	REQ_CLR	0	Clear Flag for stop command
	REQ_SET	1	Set Flag for stop command
	LED_ON_1ST_SPEED	1500	rotation speed LED3 ON
	LED_ON_2ND_SPEED	3000	rotation speed LED4 ON
	REQ_ROT_CCW	0	CCW: Acquisition value of Rotation direction port
REQ_ROT_CW	1	CW: Acquisition value of Rotation direction port	
motor_parameter.h	MP_POLE_PAIRS	2	Constant for correcting number of pole pairs
mtr_ctrl_rl78g1f_t2001.h	MTR_PWM_TIMER_FREQ	64.0f	PWM timer count frequency [MHz]
	MTR_CARRIER_FREQ	20.0f	Carrier frequency [KHz]
	MTR_DEADTIME	0	Dead Time [ns]
	MTR_DEADTIME_SET	MTR_DEADTIME MTR_PWM_TIMER_FREQ / 1000	* Dead Time setting value
	MTR_CARRIER_SET	(MTR_PWM_TIMER_FREQ * 1000 / MTR_CARRIER_FREQ / 2) + MTR_DEADTIME_SET - 2	Carrier setting value
	MTR_START_CARRIER_SET	MTR_CARRIER_SET * 30 / 100	Carrier setting value (initial value)

	MTR_VR1_ADC_MAX	802	Trigger level A/D conversion maximum value
	MTR_PWM_DUTY_CALC_COEF1	$MTR\_CARRIER\_SET * 100 / MTR\_VR1\_ADC\_MAX$	PWM Duty calculation coefficient 1
	MTR_PWM_DUTY_CALC_COEF2	100	PWM Duty calculation coefficient 2
	MTR_RPM_CALC_COEF1	556	Target rotation speed calculation coefficient 1
	MTR_RPM_CALC_COEF2	16888	Target rotation speed calculation coefficient 2
	MTR_RPM_CALC_COEF3	100	Target rotation speed calculation coefficient 3
	MTR_PORT_HALL_U	P5.2	U phase hall IC signal input port
	MTR_PORT_HALL_V	P5.3	V phase hall IC signal input port
	MTR_PORT_HALL_W	P5.4	W phase hall IC signal input port
	MTR_PORT_UP	P1.5	U phase (positive phase) output port
	MTR_PORT_UN	P1.4	U phase (negative phase) output port
	MTR_PORT_VP	P1.3	V phase (positive phase) output port
	MTR_PORT_VN	P1.1	V phase (negative phase) output port
	MTR_PORT_WP	P1.2	W phase (positive phase) output port
	MTR_PORT_WN	P1.0	W phase (negative phase) output port
	MTR_GET_ROT_DIR_REQ	P12.2	Rotation direction detection port
	MTR_PORT_LED1	P0.1	LED1 output port
	MTR_PORT_LED2	P0.0	LED2 output port
	MTR_PORT_LED3	P14.1	LED3 output port
	MTR_PORT_LED4	P14.0	LED4 output port
	MTR_PORT_LED5	P4.3	LED5 output port
	MTR_PORT_LED6	P4.2	LED6 output port
	MTR_LED_ON	0	Active in case of Low
	MTR_LED_OFF	1	
	MTR_OVERVOLTAGE_LIMIT	$30 * 128$	Over voltage error determination threshold [V]
	MTR_UNDERVOLTAGE_LIMIT	$6 * 128$	Under voltage error determination threshold [V]
	MTR_VDC_SCALING	1471	VM voltage A/D conversion value resolution
	MTR_RECIVDC_SCALING	256	VM voltage A/D conversion value resolution (inverse)
	MTR_TAU1_CNT	TCR01	TAU1 count register for rotation speed calculation
	MTR_ADCCH_RAJ306000_TEMP	0	A/D converter channel for RAJ306000 temperature measurement
	MTR_ADCCH_MOS_TEMP	1	A/D converter channel for MOS FET temperature measurement
	MTR_ADCCH_VM	3	A/D converter channel for VM voltage measurement
	MTR_ADCCH_BOARD_TEMP	5	A/D converter channel for sensor board temperature measurement
	MTR_ADCCH_VR1	6	A/D converter channel for Trigger level
	MTR_ADCCH_PDRV	7	A/D converter channel for PreDriver voltage measurement
mtr_ctrl_t2001.h	MTR_LED1	1	LED pattern
	MTR_LED2	2	
	MTR_LED3	3	
	MTR_LED4	4	
	MTR_LED5	5	

	MTR_LED6	6	
mtr_spm_hall_120_cpm.h	MTR_TWOPI	$2 * 3.14159265f$	2 Pi
	MTR_POLE_PAIRS	MP_POLE_PAIRS	Constant for compensate number of pole pairs
	MTR_RPM_RAD	1716	Constant to change units from [rpm] to [rad/s]
	MTR_RAD_RPM	$2445 / MTR\_POLE\_PAIRS$	Constant to change units from [rad/s] to [rpm]
	MTR_SPEED_LIMIT_RPM	4290	Limit value of Rotation speed (mechanical angle) [rpm]
	MTR_SPEED_LIMIT	$MTR\_SPEED\_LIMIT\_RPM / 60 * MTR\_POLE\_PAIRS * MTR\_TWOPI * 4$	Limit value of Rotation speed (electrical angle) [rad/s]
	MTR_SPEED_LPF_K	$CP\_SPEED\_LPF\_K * 16384$	LPF parameter value for Rotation speed
	MTR_SPEED_CALC_BASE	383	Constant for rotation speed measurement
	MTR_TIMER_CNT_BUF_NUM	6	Buffer size for timer count of Rotation speed measurement
	MTR_TIMEOUT_CNT	400	Waiting time for judgement of motor stop (Count value x 50[us])
	MTR_START_CNT	2000	Boot mode period (Count value x 500[us])
	MTR_PATTERN_CW_V_U	5	CW hall IC signal pattern
	MTR_PATTERN_CW_W_U	4	
	MTR_PATTERN_CW_W_V	6	
	MTR_PATTERN_CW_U_V	2	
	MTR_PATTERN_CW_U_W	3	
	MTR_PATTERN_CW_V_W	1	
	MTR_PATTERN_CCW_V_U	2	CCW hall IC signal pattern
	MTR_PATTERN_CCW_V_W	6	
	MTR_PATTERN_CCW_U_W	4	
	MTR_PATTERN_CCW_U_V	5	
	MTR_PATTERN_CCW_W_V	1	
	MTR_PATTERN_CCW_W_U	3	
	MTR_PATTERN_ERROR	0	Conducting pattern
	MTR_UP_PWM_VN_ON	1	
	MTR_UP_PWM_WN_ON	2	
	MTR_VP_PWM_UN_ON	3	
	MTR_VP_PWM_WN_ON	4	
	MTR_WP_PWM_UN_ON	5	
	MTR_WP_PWM_VN_ON	6	
	MTR_UP_ON_VN_PWM	7	
	MTR_UP_ON_WN_PWM	8	
	MTR_VP_ON_UN_PWM	9	
	MTR_VP_ON_WN_PWM	10	
MTR_WP_ON_UN_PWM	11		
MTR_WP_ON_VN_PWM	12		
MTR_CW	0	Rotation direction setting value: CW	
MTR_CCW	1	Rotation direction setting value: CCW	
MTR_FLG_CLR	0	Constant for flag clear	
MTR_FLG_SET	1	Constant for flag setting	
MTR_STOP_WAIT_CNT	200	Period to wait for motor stop (Count value x 50[us])	



	MTR_ICS_DECIMATION	4	Number of function call decimation times for ICS (Count value x 50[us])
	MTR_BOOT_MODE	0x00	Boot mode
	MTR_HALL_120_MODE	0x03	Normal operation (HALL 120) mode
	MTR_ALARM_ERROR	0x01	ALARM error
	MTR_OVER_VOLTAGE_ERROR	0x02	Over voltage error
	MTR_OVER_SPEED_ERROR	0x04	Rotation speed abnormality error
	MTR_TIMEOUT_ERROR	0x08	Timeout error
	MTR_HALL_ERROR	0x10	Hall IC signal pattern error
	MTR_UNDER_VOLTAGE_ERROR	0x40	Under voltage error
	MTR_UNKNOWN_ERROR	0x80	Undefined error
	MTR_MODE_STOP	0x00	Stop status
	MTR_MODE_RUN	0x01	Rotating status
	MTR_MODE_ERROR	0x02	Error status
	MTR_SIZE_STATE	3	Status count
	MTR_EVENT_STOP	0x00	Motor stop event
	MTR_EVENT_RUN	0x01	Motor startup event
	MTR_EVENT_ERROR	0x02	Motor error event
	MTR_EVENT_RESET	0x03	Motor reset event
	MTR_SIZE_EVENT	4	Events count
version.h	FW_REVISION	107	F/W Revision information

File Name	Macro Name	Content	Remark
r_cg_userdefine.h	SPI00_CS_H	P0 = P0   0x20	SPI communication Chip Select signal = H
	SPI00_CS_L	P0 = P0 & 0xDF	SPI communication Chip Select signal = L
	SPI_WAIT_MODE	0x01	SPI communication Wait mode
	SPI_INTR_MODE	0x02	SPI communication Interrupt mode
	SPI_ADC_MODE	0x03	SPI communication ADC mode

File Name	Macro Name	Content	Remarks	
r_cg_predrv.h	REG_BUFF_SIZE	2	PreDriver register buffer size	
	SPI_CHK_MAX	100	PreDriver SPI communication check count	
	PREDRV_NORMAL	0	PreDriver sequence none	
	PREDRV_SPI_ERROR	1	PreDriver sequence SPI communication error	
	PREDRV_ALARM_ERROR	2	PreDriver sequence ALARM error	
	PREDRV_REGRW_ERROR	4	PreDriver sequence Register R/W error	
	MOTOR_LOCK	0	Motor lock status	
	MOTOR_UNLOCK	1	Motor unlock status	
	PREDRV_SPI_ACCESS_OK	0x6A	PreDriver SPI communication judgement	
	PREDRV_ALMRAW1_OK	0xEF	PreDriver ALMRAW1 judgement	
	ALMSTS1_TSD_N	0x01	ALARM Status1 judgement	
	ALMSTS1_OCP_N	0x02		
	ALMSTS1_VGB_UVP_N	0x04		
	ALMSTS1_VGB_OVP_N	0x08		
	ALMSTS1_VGT_UVP_N	0x10		
	ALMSTS1_VGT_OVP2_N	0x20		
	ALMSTS1_VGT_OVP1_N	0x40		
	ALMSTS1_VREG5_OVP_N	0x80		
	ALMSTS1_NO_ERROR	0xEF		
	ALMSTS1_VGT_UVP_MASK	0xEF		
	ALMSTS2_VM_UVP_N	0x01		ALARM Status2 judgement
	ALMSTS2_DI_SEL_W_CMP_N	0x20		
	ALMSTS2_DI_SEL_V_CMP_N	0x40		
	ALMSTS2_DI_SEL_U_CMP_N	0x80		
	ALMSTS2_NO_ERROR	0xFF		
	WHO_AM_I_MASK	0xFE	WHO_AM_I mask	
	INIT_PS_ALL	0x01	PS_ALL initial value	
	INIT_PS_1ST	0x3E	PS initial value 1st	
	INIT_PS_2ND	0x3F	PS initial value 2nd	
	INIT_PS_3RD	0xBF	PS initial value 3rd	
	INIT_SELSIG_U	0x03	SELSIG_U initial value	
	INIT_SELSIG_V	0x14	SELSIG_V initial value	
	INIT_SELSIG_W	0x25	SELSIG_W initial value	
	INIT_HALL_SIG	0x00	HALL_SIG initial value	
INIT_ALMOPE1	0x10	ALMOPE1 initial value		
INIT_ALMOUT1	0x10	ALMOUT1 initial value		

INIT_CS_SET2	0x60	CS_SET2 initial value
INIT_ERROR_WAIT	0x00	ERROR_WAIT initial value
INIT_CS_SET1	0x08	CS_SET1 initial value
INIT_HAIC_TH	0x00	HAIC_TH initial value
INIT_LD_WAIT	0x00	LD_WAIT initial value
INIT_DRIVE_SET	0x01	DRIVE_SET initial value
INIT_IDRCNT_H	0x00	IDRCNT_H initial value
INIT_IDRCNT_L	0x00	IDRCNT_L initial value
INIT_TRCNT_P	0x00	TRCNT_P initial value
INIT_CPSET1	0x01	CPSET1 initial value
INIT_CPSET2	0x02	CPSET2 initial value
INIT_CP_TRIM	0x00	CP_TRIM initial value
INIT_VREG5_TRIM	0x20	VREG5_TRIM initial value
INIT_CSAMP_TRIM	0x20	CSAMP_TRIM initial value
INIT_TRIM_PT	0x00	TRIM_PT initial value protected
INIT_TRIM_PT_UP	0x95	TRIM_PT initial value unprotected
INIT_TRIM_EN	0x00	TRIM_EN initial value
INIT_TRIM_EN_EFWD	0x01	TRIM_EN initial value valid trimming data
INIT_BGR_TRIM	0x00	BGR_TRIM initial value
INIT_BFAMP_TRIM	0x00	BFAMP_TRIM initial value
ERRRCV_PS_1ST	0x3C	PS ALARM recovery value 1st
ERRRCV_PS_2ND	0x3E	PS ALARM recovery value 2nd
ERRRCV_PS_3RD	0x3F	PS ALARM recovery value 3rd
ERRRCV_PS_4TH	0xBF	PS ALARM recovery value 4th
ERRRCV_MOT_EN_CLR	0x00	DRIVE_SET ALARM recovery value Prohibition of motor rotation
ERRRCV_MOT_EN_SET	0x01	DRIVE_SET ALARM recovery value Permission of motor rotation
ERRRCV_ALM_LATCH_CLR	0x40	DRIVE_SET ALARM recovery value Clear of ALARM latch
WAITTIME_1_MS	0x11F8	1[ms] wait
WAITTIME_3_MS	0x35E8	3[ms] wait
INIT_ICS_PS_ALL	INIT_PS_ALL	PS_ALL ICS variable initial value

INIT_ICS_PS	INIT_PS_3RD	PS ICS variable initial value
INIT_ICS_SW_RESET	0x00	SW_RESET ICS variable initial value
INIT_ICS_ADC_SEL	0x00	ADC_SEL ICS variable initial value
INIT_ICS_SELSIG_U	0x03	SELSIG_U ICS variable initial value
INIT_ICS_SELSIG_V	0x14	SELSIG_V ICS variable initial value
INIT_ICS_SELSIG_W	0x25	SELSIG_W ICS variable initial value
INIT_ICS_HALL_SIG	0x00	HALL_SIG ICS variable initial value
INIT_ICS_ALMSTS1	0xFF	ALMSTS1 ICS variable initial value
INIT_ICS_ALMOPE1	INIT_ALMOPE1	ALMOPE1 ICS variable initial value
INIT_ICS_ALMOUT1	INIT_ALMOUT1	ALMOUT1 ICS variable initial value
INIT_ICS_ALMSTS2	0xFF	ALMSTS2 ICS variable initial value
INIT_ICS_CS_SET2	INIT_CS_SET2	CS_SET2 ICS variable initial value
INIT_ICS_ALMOUT2	0x00	ALMOUT2 ICS variable initial value
INIT_ICS_ERROR_WAIT	0x00	ERROR_WAIT ICS variable initial value
INIT_ICS_CS_SET1	INIT_CS_SET1	CS_SET1 ICS variable initial value
INIT_ICS_HAIC_TH	0x00	HAIC_TH ICS variable initial value
INIT_ICS_PDDSTS	0xF0	PDDSTS ICS variable initial value
INIT_ICS_LD_WAIT	0x00	LD_WAIT ICS variable initial value
INIT_ICS_DRIVE_SET	INIT_DRIVE_SET	DRIVE_SET ICS variable initial value
INIT_ICS_DI_TIME	0x00	DI_TIME ICS variable initial value
INIT_ICS_IDRCNT_H	0x00	IDRCNT_H ICS variable initial value
INIT_ICS_IDRCNT_L	0x00	IDRCNT_L ICS variable initial value
INIT_ICS_TRCNT_P	0x00	TRCNT_P ICS variable initial value
INIT_ICS_CPSET1	0x01	CPSET1 ICS variable initial value
INIT_ICS_CPSET2	0x02	CPSET2 ICS variable initial value
INIT_ICS_CP_TRIM	INIT_CP_TRIM	CP_TRIM ICS variable initial value
INIT_ICS_VREG5_TRIM	INIT_VREG5_TRIM	VREG5_TRIM ICS variable initial value

INIT_ICS_CSAMP_TRIM	INIT_CSAMP_TRIM	CSAMP_TRIM ICS variable initial value
INIT_ICS_ALMRAW1	0xFF	ALMRAW1 ICS variable initial value
INIT_ICS_TOIN_MONI	0x00	TOIN_MONI ICS variable initial value
INIT_ICS_WHO_AM_I	0x6A	WHO_AM_I ICS variable initial value
INIT_ICS_TRIM_PT	INIT_TRIM_PT	TRIM_PT ICS variable initial value
INIT_ICS_TRIM_EN	INIT_TRIM_EN	TRIM_EN ICS variable initial value
INIT_ICS_BGR_TRIM	INIT_BGR_TRIM	BGR_TRIM ICS variable initial value
INIT_ICS_BFAMP_TRIM	INIT_BFAMP_TRIM	BFAMP_TRIM ICS variable initial value
SEQ_INIT	0	PreDriver initial sequence definition
SEQ_CHK_SPI	1	
SEQ_CHK_TSD_N	2	
SEQ_SET_5VTRIM	3	
SEQ_SET_ALMOPE1_PRM	4	
SEQ_SET_ALMOUT1_PRM	5	
SEQ_SET_CS_SET2_PRM	6	
SEQ_SET_CS_SET1_PRM	7	
SEQ_SET_SEQINIT_PRM	8	
SEQ_SET_PS_ALL_PRM	9	
SEQ_SET_PS_1ST_PRM	10	
SEQ_SET_PS_2ND_PRM	11	
SEQ_CHK_ALMRAW1	12	
SEQ_SET_PS_3RD_PRM	13	
SEQ_CHK_ALMSTS	14	
SEQ_SET_MOT_EN	15	
SEQ_END	16	
SEQ_NUM_MAX	17	
ERR_RCV_SEQ_INIT	0	PreDriver ALARM recovery sequence definition
ERR_RCV_SEQ_CHK_STS	1	
ERR_RCV_SEQ_CLR_MOT_EN	2	
ERR_RCV_SEQ_SET_PS_1ST	3	
ERR_RCV_SEQ_CHK_ALMSTS_1ST	4	
ERR_RCV_SEQ_SET_ALM_LATCH_CLR	5	
ERR_RCV_SEQ_SET_PS_2ND	6	
ERR_RCV_SEQ_SET_PS_3RD	7	
ERR_RCV_SEQ_CHK_ALMRAW1	8	
ERR_RCV_SEQ_SET_PS_4TH	9	
ERR_RCV_SEQ_CHK_ALMSTS_2ND	10	
ERR_RCV_SEQ_SET_MOT_EN	11	
ERR_RCV_SEQ_END	12	
ERR_RCV_SEQ_NUM_MAX	13	

### 3.5 Flow chart

Figure 3-5 shows the whole flow chart and the flow chart of initialization function.

Also, flow chart of main processing in sample program are shown in Figure 3-5 to Figure 3-12.

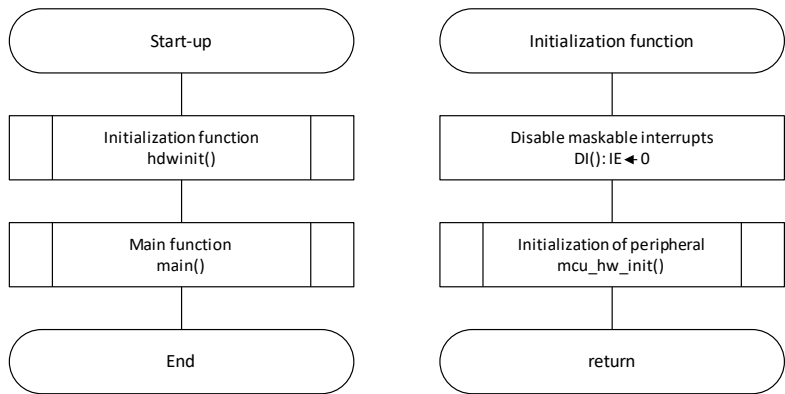

**Figure 3-5 Flow chart (Overall and Initialization function)**

3.5.1 Main function

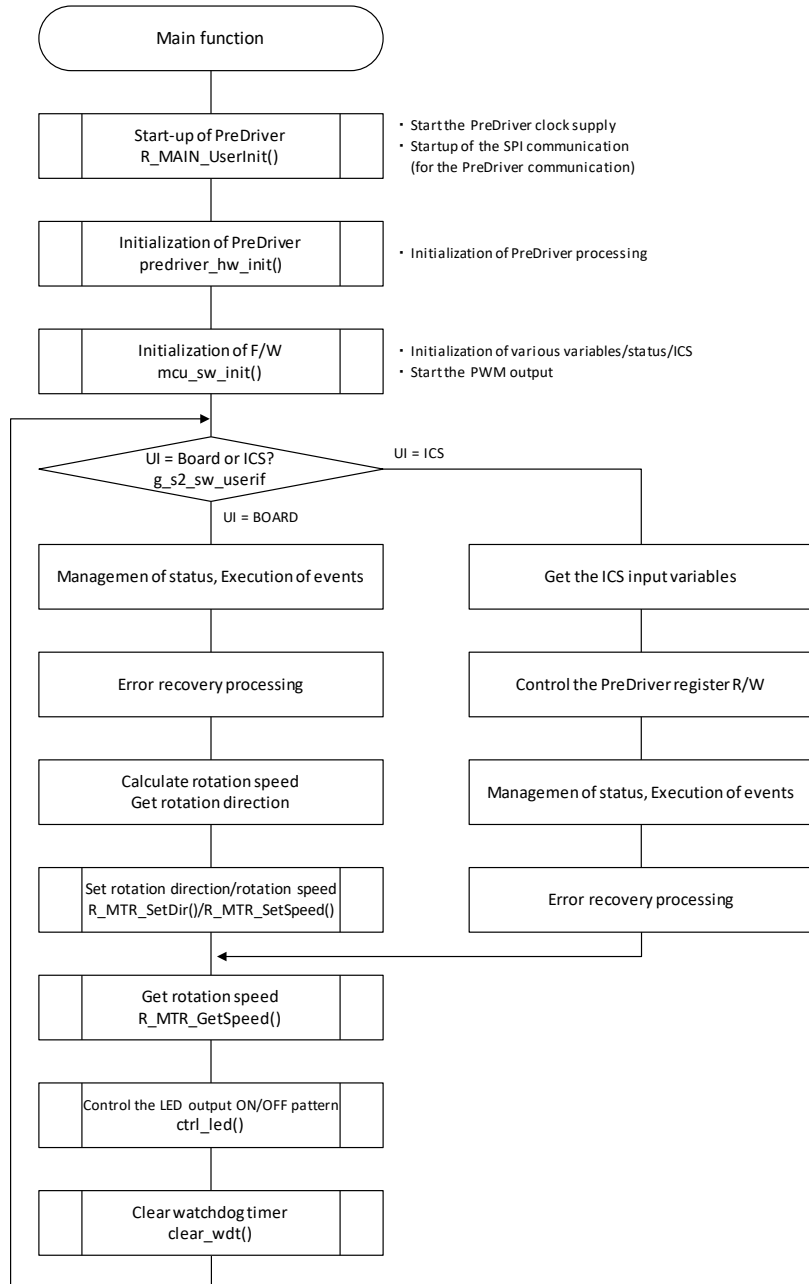

Figure 3-6 Flow chart (Main function)

3.5.2 Initialization of PreDriver processing

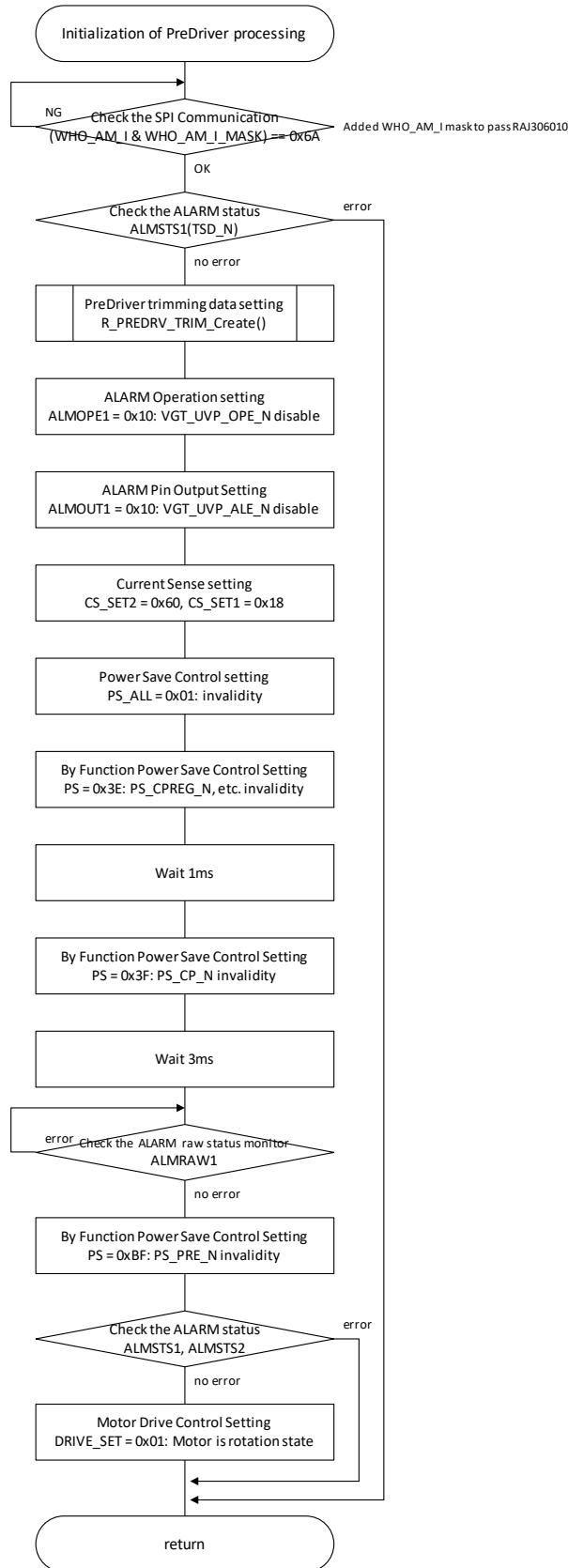

Figure 3-7 Flow chart (Initialization of PreDriver processing)



3.5.3 Hall IC signal interruption processing

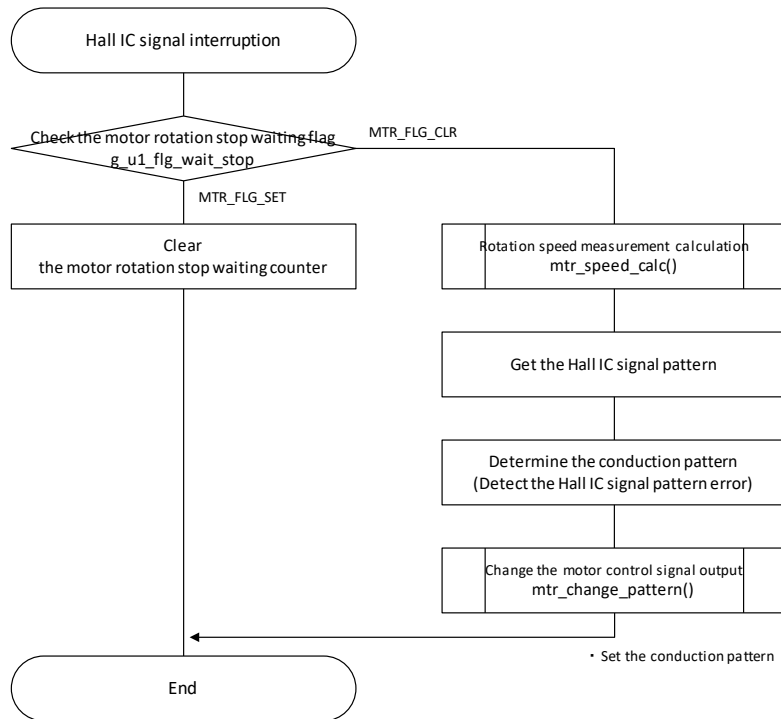

Figure 3-8 Flow chart (Hall IC signal interruption processing)

3.5.4 Carrier frequency interruption processing

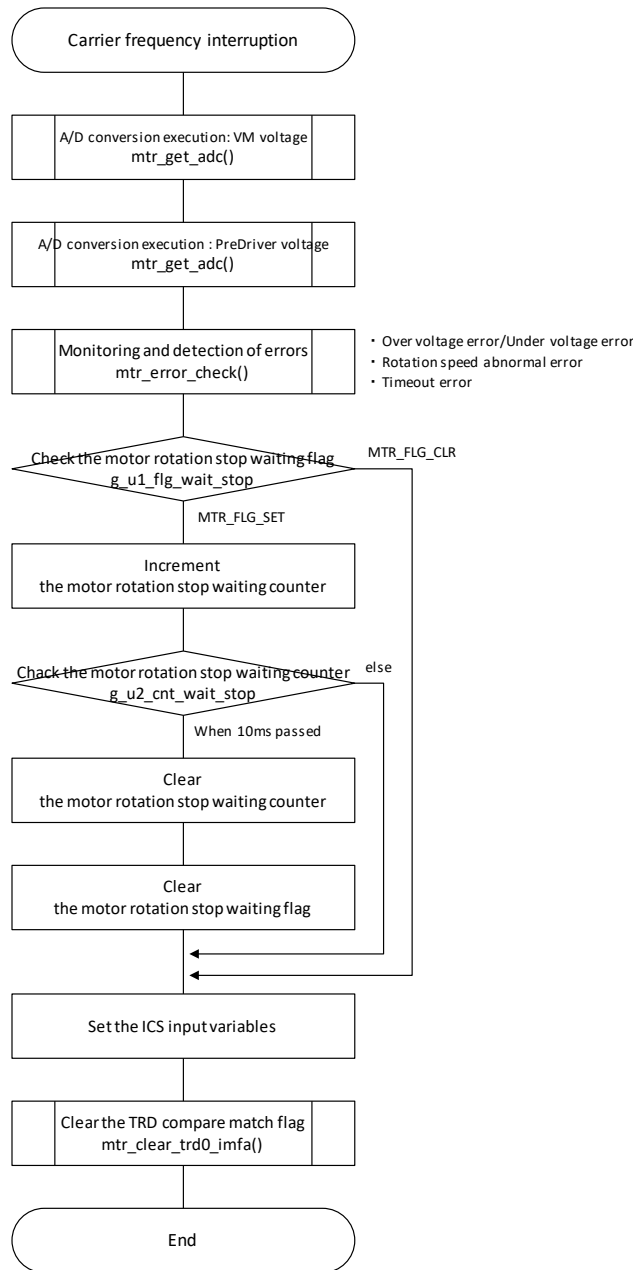

Figure 3-9 Flow chart (Carrier frequency interruption processing)

3.5.5 500[us] interruption processing

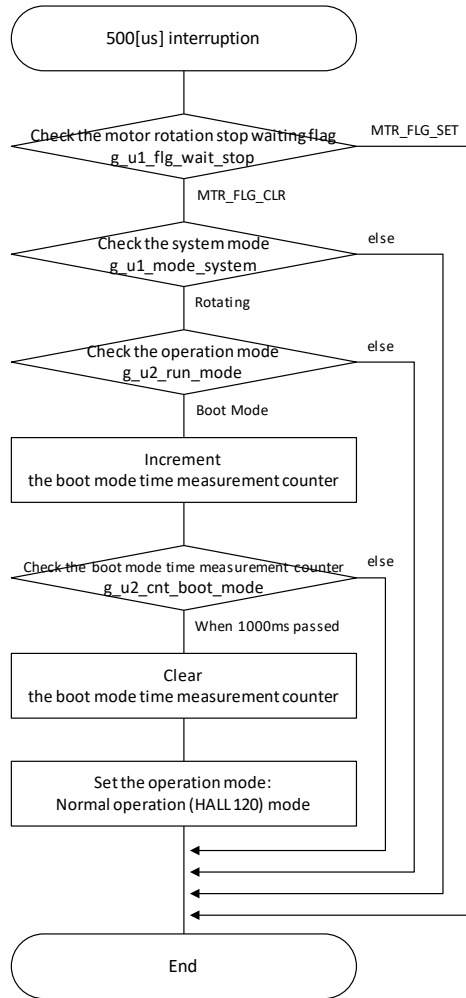
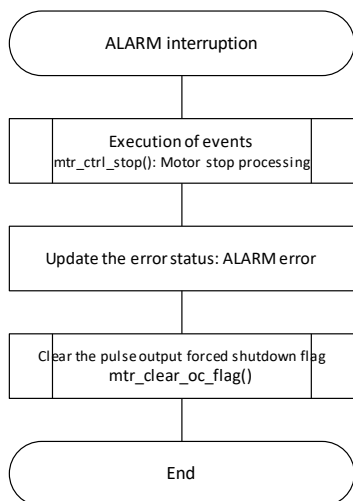

Figure 3-10 Flow chart (500[us] interruption processing)

### 3.5.6 ALARM interruption processing



**Figure 3-11 Flow chart (ALARM interruption processing)**

3.5.7 ALARM recovery processing

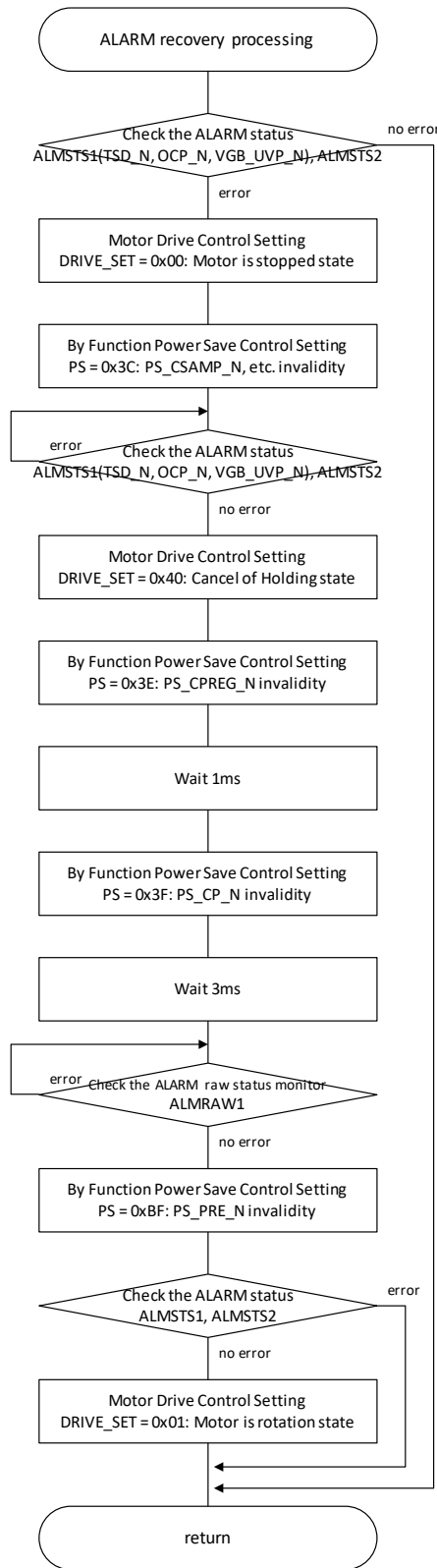

Figure 3-12 Flow chart (ALARM recovery processing)

## 4. Development support tool In Circuit Scope

### 4.1 Overview

In the target sample programs described in this application note, user interfaces (rotating/stop command, rotation speed command, etc.) based on the development support tool 'In Circuit Scope' (ICS) can be used. ICS is a tool which displays on PC real-time waveforms of global variables of the program being executed on the target system. Refer to 'In Circuit Scope manual' for usage and more details.

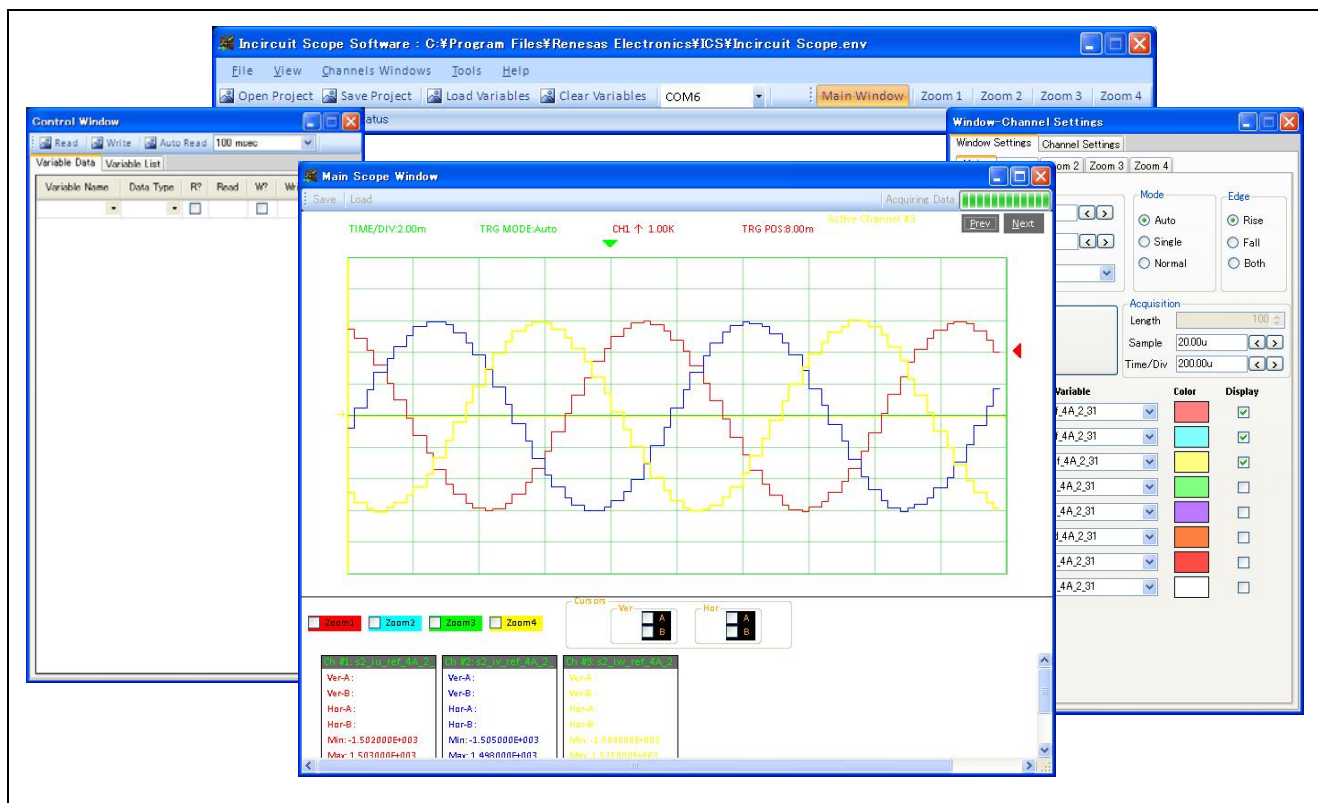

Figure 4-1 In Circuit Scope - Appearance

### 4.2 How to use library

In order to use ICS, it is necessary to call functions related to ICS. The ICS-related functions have been set by conditional compilation (`#ifdef--#endif`). To use ICS, set as follows.

[File name] `mtr_common.h`

[Point to change] Add the following declaration.

```
#define ICS_USE
```

### 4.3 List of variables for ICS

Table 4-1 and Table 4-2 are list of variables for ICS. Table 4-1 variable values are reflected to the protect variables when the same values as g\_s2\_enable\_write are written to com\_s2\_enable\_write.

Table 4-2 variable values do not depend on com\_s2\_enable\_write.

**Table 4-1 List of Variables for ICS**

Variable bame	Type	Content	Remarks ([ ]: protect variable name)
com_s2_direction	int16_t	Rotation direction 0: CW, 1: CCW	[g_u1_direction]
com_s2_ref_speed_rpm	int16_t	Rotation speed command value (mechanical angle) [rpm] <b>* Not Used</b>	[g_s2_ref_speed]
com_s2_speed_lpf_k	int16_t	speed LPF parameter	[g_s2_speed_lpf_k]
com_s2_enable_write	int16_t	Enable to rewriting variables	-

**Table 4-2 List of Variables for ICS**

Variable name	Type	Content	Remarks
com_s2_sw_userif	int16_t	User interface switch 0: ICS user interface use 1: Board user interface use	-
com_s2_mode_system	int16_t	State management 0: Stop mode 1: Run mode 3: Reset	-
com_s2_pwm_duty	int16_t	Compare register setting value of Timer RD	PWM Duty setting value: 0 to 1598 PWM Duty [%]: 0 to 100
com_u1_pdrvreg_ctrl	uint8_t	PreDriver register R/W control flag	0: R/W disable 1: R/W enable
com_u1_pdrvreg_ps_all_pre	uint8_t	PreDriver register PS_ALL previous value	Read value
com_u1_pdrvreg_ps_all_now	uint8_t	PreDriver register PS_ALL current value	Write value
com_u1_pdrvreg_ps_pre	uint8_t	PreDriver register PS previous value	Read value
com_u1_pdrvreg_ps_now	uint8_t	PreDriver register PS current value	Write value
com_u1_pdrvreg_sw_reset_pre	uint8_t	PreDriver register SW_RESET previous value	Read value
com_u1_pdrvreg_sw_reset_now	uint8_t	PreDriver register SW_RESET current value	Write value
com_u1_pdrvreg_adc_sel_pre	uint8_t	PreDriver register ADC_SEL previous value	Read value
com_u1_pdrvreg_adc_sel_now	uint8_t	PreDriver register ADC_SEL current value	Write value
com_u1_pdrvreg_selsig_u_pre	uint8_t	PreDriver register SELSIG_U previous value	Read value
com_u1_pdrvreg_selsig_u_now	uint8_t	PreDriver register SELSIG_U current value	Write value
com_u1_pdrvreg_selsig_v_pre	uint8_t	PreDriver register SELSIG_V previous value	Read value
com_u1_pdrvreg_selsig_v_now	uint8_t	PreDriver register SELSIG_V current value	Write value
com_u1_pdrvreg_selsig_w_pre	uint8_t	PreDriver register SELSIG_W previous value	Read value
com_u1_pdrvreg_selsig_w_now	uint8_t	PreDriver register SELSIG_W current value	Write value
com_u1_pdrvreg_hall_sig_pre	uint8_t	PreDriver register HALL_SIG previous value	Read value
com_u1_pdrvreg_hall_sig_now	uint8_t	PreDriver register HALL_SIG current value	Write value
com_u1_pdrvreg_almsts1_pre	uint8_t	PreDriver register ALMSTS1 previous value	Read value (ALMSTS1 Read Only)
com_u1_pdrvreg_almope1_pre	uint8_t	PreDriver register ALMOPE1 previous value	Read value
com_u1_pdrvreg_almope1_now	uint8_t	PreDriver register ALMOPE1 current value	Write value

com_u1_pdrvreg_almout1_pre	uint8_t	PreDriver register ALMOUT1 previous value	Read value
com_u1_pdrvreg_almout1_now	uint8_t	PreDriver register ALMOUT1 current value	Write value
com_u1_pdrvreg_almsts2_pre	uint8_t	PreDriver register ALMSTS2 previous value	Read value (ALMSTS2 Read Only)
com_u1_pdrvreg_cs_set2_pre	uint8_t	PreDriver register CS_SET2 previous value	Read value
com_u1_pdrvreg_cs_set2_now	uint8_t	PreDriver register CS_SET2 current value	Write value
com_u1_pdrvreg_almout2_pre	uint8_t	PreDriver register ALMOUT2 previous value	Read value
com_u1_pdrvreg_almout2_now	uint8_t	PreDriver register ALMOUT2 current value	Write value
com_u1_pdrvreg_error_wait_pre	uint8_t	PreDriver register ERROR_WAIT previous value	Read value
com_u1_pdrvreg_error_wait_now	uint8_t	PreDriver register ERROR_WAIT current value	Write value
com_u1_pdrvreg_cs_set1_pre	uint8_t	PreDriver register CS_SET1 previous value	Read value
com_u1_pdrvreg_cs_set1_now	uint8_t	PreDriver register CS_SET1 current value	Write value
com_u1_pdrvreg_haic_th_pre	uint8_t	PreDriver register HAIC_TH previous value	Read value
com_u1_pdrvreg_haic_th_now	uint8_t	PreDriver register HAIC_TH current value	Write value
com_u1_pdrvreg_pddsts_pre	uint8_t	PreDriver register PDDSTS previous value	Read value (PDDSTS Read Only)
com_u1_pdrvreg_ld_wait_pre	uint8_t	PreDriver register LD_WAIT previous value	Read value
com_u1_pdrvreg_ld_wait_now	uint8_t	PreDriver register LD_WAIT current value	Write value
com_u1_pdrvreg_drive_set_pre	uint8_t	PreDriver register DRIVE_SET previous value	Read value
com_u1_pdrvreg_drive_set_now	uint8_t	PreDriver register DRIVE_SET current value	Write value
com_u1_pdrvreg_di_time_pre	uint8_t	PreDriver register DI_TIME previous value	Read value
com_u1_pdrvreg_di_time_now	uint8_t	PreDriver register DI_TIME current value	Write value
com_u1_pdrvreg_idrcnt_h_pre	uint8_t	PreDriver register IDRCNT_H previous value	Read value
com_u1_pdrvreg_idrcnt_h_now	uint8_t	PreDriver register IDRCNT_H current value	Write value
com_u1_pdrvreg_idrcnt_l_pre	uint8_t	PreDriver register IDRCNT_L previous value	Read value
com_u1_pdrvreg_idrcnt_l_now	uint8_t	PreDriver register IDRCNT_L current value	Write value
com_u1_pdrvreg_trcnt_p_pre	uint8_t	PreDriver register TRCNT_P previous value	Read value
com_u1_pdrvreg_trcnt_p_now	uint8_t	PreDriver register TRCNT_P current value	Write value
com_u1_pdrvreg_cpset1_pre	uint8_t	PreDriver register CPSET1 previous value	Read value
com_u1_pdrvreg_cpset1_now	uint8_t	PreDriver register CPSET1 current value	Write value
com_u1_pdrvreg_cpset2_pre	uint8_t	PreDriver register CPSET2 previous value	Read value
com_u1_pdrvreg_cpset2_now	uint8_t	PreDriver register CPSET2 current value	Write value
com_u1_pdrvreg_cp_trim_pre	uint8_t	PreDriver register CP_TRIM previous value	Read value
com_u1_pdrvreg_cp_trim_now	uint8_t	PreDriver register CP_TRIM current value	Write value
com_u1_pdrvreg_vreg5_trim_pre	uint8_t	PreDriver register VREG5_TRIM previous value	Read value
com_u1_pdrvreg_vreg5_trim_now	uint8_t	PreDriver register VREG5_TRIM current value	Write value
com_u1_pdrvreg_csamp_trim_pre	uint8_t	PreDriver register CSAMP_TRIM previous value	Read value
com_u1_pdrvreg_csamp_trim_now	uint8_t	PreDriver register CSAMP_TRIM current value	Write value
com_u1_pdrvreg_almraw1_pre	uint8_t	PreDriver register ALMRAW1 previous value	Read value (ALMRAW1 Read Only)
com_u1_pdrvreg_toin_moni_pre	uint8_t	PreDriver register TOIN_MONI previous value	Read value (TOIN_MONI Read Only)
com_u1_pdrvreg_who_am_i_pre	uint8_t	PreDriver register WHO_AM_I previous value	Read value (WHO_AM_I Read Only)
com_u1_pdrvreg_trim_pt_pre	uint8_t	PreDriver register TRIM_PT previous value	Read value
com_u1_pdrvreg_trim_pt_now	uint8_t	PreDriver register TRIM_PT current value	Write value
com_u1_pdrvreg_trim_en_pre	uint8_t	PreDriver register TRIM_EN previous value	Read value
com_u1_pdrvreg_trim_en_now	uint8_t	PreDriver register TRIM_EN current value	Write value
com_u1_pdrvreg_bgr_trim_pre	uint8_t	PreDriver register BGR_TRIM previous value	Read value
com_u1_pdrvreg_bgr_trim_now	uint8_t	PreDriver register BGR_TRIM current value	Write value
com_u1_pdrvreg_bfamp_trim_pre	uint8_t	PreDriver register BFAMP_TRIM previous value	Read value
com_u1_pdrvreg_bfamp_trim_now	uint8_t	PreDriver register BFAMP_TRIM current value	Write value



## Revision History

Rev.	Date	Description	
		Page	Summary
1.00	Jan.13.17	-	First edition issued.
1.01	Mar.03.17	-	Correction of errors.
1.02	Mar.22.17	-	Correction of errors. Table 3-6: g_s2_ref_speed_rad, g_s2_speed_rad Table 4-2: com_s2_pwm_duty
1.03	May.19.17	-	RAJ306000_HALL_120_OPEN_V101 Correction of errors. Table 3-4, 5, 6, 7: r_cg_predrv.c, r_cg_predrv_user.c, etc. Change PreDriver register abbreviation. Table 3-7, 4-2: CS_SET1, CS_SET2, REGV5(_TRIM), ALMRAW1 Add flowchart (Overall and Initialization function). Figure 3-5
1.04	Jul.31.17	-	RAJ306000_HALL_120_OPEN_V102 Change the RAJ306000GFT to the RAJ306000. Correction of errors. Table 2-10, 12: mtr_spm_hall_120_cpm.c Table 3-6: g_u2_cnt_boot_mode Table 3-7: MTR_START_CNT, etc.
1.05	Dec.22.17	-	RAJ306000_HALL_120_OPEN_V103 Change definition value of macro definitions. Table 3-7: MTR_RPM_RAD, MTR_RAD_RPM, INIT_CS_SET1 Correction of errors. Table 3-7: CHATTERING_CNT, MTR_RPM_CALC_COEF*, etc. Figure 2-4, 5, 3-9, 10
1.06	Jan.09.19	-	RAJ306000_HALL_120_OPEN_V104 Change parameters for RSSK (TG-55L-KA). Correction of errors. Table 2-2: P52/INTP1 Table 3-6: g_u2_fw_revision Table 3-7: SPI_INTR_MODE, POLE_PAIR, etc.
1.07	May.10.19	-	RAJ306000_HALL_120_OPEN_*_*_V105 Support IDE: CS+ for CC, e <sup>2</sup> studio Table 1-1, 2-10, 11 Change parameters. Table 3-7: MARGIN_SPEED, MTR_RECIVDC_SCALING Correction of errors. Figure 3-9, etc.
1.08	Jul.17.19	-	RAJ306000_HALL_120_OPEN_*_*_V106 Change library for ICS. Table 2-10: ics
1.09	Mar.31.20	-	RAJ306000_HALL_120_OPEN_*_*_V107 Added macro definition (WHO_AM_I_MASK) Figure 3-7, Table 3-7 Correction of errors. Table 4-2: TRIM_PT, TRIM_EN, BGR_TRIM, BFAMP_TRIM, etc.

## General Precautions in the Handling of Microprocessing Unit and Microcontroller Unit Products

The following usage notes are applicable to all Microprocessing unit and Microcontroller unit products from Renesas. For detailed usage notes on the products covered by this document, refer to the relevant sections of the document as well as any technical updates that have been issued for the products.

### 1. Precaution against Electrostatic Discharge (ESD)

A strong electrical field, when exposed to a CMOS device, can cause destruction of the gate oxide and ultimately degrade the device operation. Steps must be taken to stop the generation of static electricity as much as possible, and quickly dissipate it when it occurs. Environmental control must be adequate. When it is dry, a humidifier should be used. This is recommended to avoid using insulators that can easily build up static electricity.

Semiconductor devices must be stored and transported in an anti-static container, static shielding bag or conductive material. All test and measurement tools including work benches and floors must be grounded. The operator must also be grounded using a wrist strap. Semiconductor devices must not be touched with bare hands. Similar precautions must be taken for printed circuit boards with mounted semiconductor devices.

### 2. Processing at power-on

The state of the product is undefined at the time when power is supplied. The states of internal circuits in the LSI are indeterminate and the states of register settings and pins are undefined at the time when power is supplied. In a finished product where the reset signal is applied to the external reset pin, the states of pins are not guaranteed from the time when power is supplied until the reset process is completed. In a similar way, the states of pins in a product that is reset by an on-chip power-on reset function are not guaranteed from the time when power is supplied until the power reaches the level at which resetting is specified.

### 3. Input of signal during power-off state

Do not input signals or an I/O pull-up power supply while the device is powered off. The current injection that results from input of such a signal or I/O pull-up power supply may cause malfunction and the abnormal current that passes in the device at this time may cause degradation of internal elements. Follow the guideline for input signal during power-off state as described in your product documentation.

### 4. Handling of unused pins

Handle unused pins in accordance with the directions given under handling of unused pins in the manual. The input pins of CMOS products are generally in the high-impedance state. In operation with an unused pin in the open-circuit state, extra electromagnetic noise is induced in the vicinity of the LSI, an associated shoot-through current flows internally, and malfunctions occur due to the false recognition of the pin state as an input signal become possible.

### 5. Clock signals

After applying a reset, only release the reset line after the operating clock signal becomes stable. When switching the clock signal during program execution, wait until the target clock signal is stabilized. When the clock signal is generated with an external resonator or from an external oscillator during a reset, ensure that the reset line is only released after full stabilization of the clock signal. Additionally, when switching to a clock signal produced with an external resonator or by an external oscillator while program execution is in progress, wait until the target clock signal is stable.

### 6. Voltage application waveform at input pin

Waveform distortion due to input noise or a reflected wave may cause malfunction. If the input of the CMOS device stays in the area between  $V_{IL}$  (Max.) and  $V_{IH}$  (Min.) due to noise, for example, the device may malfunction. Take care to prevent chattering noise from entering the device when the input level is fixed, and also in the transition period when the input level passes through the area between  $V_{IL}$  (Max.) and  $V_{IH}$  (Min.).

### 7. Prohibition of access to reserved addresses

Access to reserved addresses is prohibited. The reserved addresses are provided for possible future expansion of functions. Do not access these addresses as the correct operation of the LSI is not guaranteed.

### 8. Differences between products

Before changing from one product to another, for example to a product with a different part number, confirm that the change will not lead to problems. The characteristics of a microprocessing unit or microcontroller unit products in the same group but having a different part number might differ in terms of internal memory capacity, layout pattern, and other factors, which can affect the ranges of electrical characteristics, such as characteristic values, operating margins, immunity to noise, and amount of radiated noise. When changing to a product with a different part number, implement a system-evaluation test for the given product.

## Notice

1. Descriptions of circuits, software and other related information in this document are provided only to illustrate the operation of semiconductor products and application examples. You are fully responsible for the incorporation or any other use of the circuits, software, and information in the design of your product or system. Renesas Electronics disclaims any and all liability for any losses and damages incurred by you or third parties arising from the use of these circuits, software, or information.
  2. Renesas Electronics hereby expressly disclaims any warranties against and liability for infringement or any other claims involving patents, copyrights, or other intellectual property rights of third parties, by or arising from the use of Renesas Electronics products or technical information described in this document, including but not limited to, the product data, drawings, charts, programs, algorithms, and application examples.
  3. No license, express, implied or otherwise, is granted hereby under any patents, copyrights or other intellectual property rights of Renesas Electronics or others.
  4. You shall not alter, modify, copy, or reverse engineer any Renesas Electronics product, whether in whole or in part. Renesas Electronics disclaims any and all liability for any losses or damages incurred by you or third parties arising from such alteration, modification, copying or reverse engineering.
  5. Renesas Electronics products are classified according to the following two quality grades: "Standard" and "High Quality". The intended applications for each Renesas Electronics product depends on the product's quality grade, as indicated below.
    - "Standard": Computers; office equipment; communications equipment; test and measurement equipment; audio and visual equipment; home electronic appliances; machine tools; personal electronic equipment; industrial robots; etc.
    - "High Quality": Transportation equipment (automobiles, trains, ships, etc.); traffic control (traffic lights); large-scale communication equipment; key financial terminal systems; safety control equipment; etc.
- Unless expressly designated as a high reliability product or a product for harsh environments in a Renesas Electronics data sheet or other Renesas Electronics document, Renesas Electronics products are not intended or authorized for use in products or systems that may pose a direct threat to human life or bodily injury (artificial life support devices or systems; surgical implantations; etc.), or may cause serious property damage (space system; undersea repeaters; nuclear power control systems; aircraft control systems; key plant systems; military equipment; etc.). Renesas Electronics disclaims any and all liability for any damages or losses incurred by you or any third parties arising from the use of any Renesas Electronics product that is inconsistent with any Renesas Electronics data sheet, user's manual or other Renesas Electronics document.
6. When using Renesas Electronics products, refer to the latest product information (data sheets, user's manuals, application notes, "General Notes for Handling and Using Semiconductor Devices" in the reliability handbook, etc.), and ensure that usage conditions are within the ranges specified by Renesas Electronics with respect to maximum ratings, operating power supply voltage range, heat dissipation characteristics, installation, etc. Renesas Electronics disclaims any and all liability for any malfunctions, failure or accident arising out of the use of Renesas Electronics products outside of such specified ranges.
  7. Although Renesas Electronics endeavors to improve the quality and reliability of Renesas Electronics products, semiconductor products have specific characteristics, such as the occurrence of failure at a certain rate and malfunctions under certain use conditions. Unless designated as a high reliability product or a product for harsh environments in a Renesas Electronics data sheet or other Renesas Electronics document, Renesas Electronics products are not subject to radiation resistance design. You are responsible for implementing safety measures to guard against the possibility of bodily injury, injury or damage caused by fire, and/or danger to the public in the event of a failure or malfunction of Renesas Electronics products, such as safety design for hardware and software, including but not limited to redundancy, fire control and malfunction prevention, appropriate treatment for aging degradation or any other appropriate measures. Because the evaluation of microcomputer software alone is very difficult and impractical, you are responsible for evaluating the safety of the final products or systems manufactured by you.
  8. Please contact a Renesas Electronics sales office for details as to environmental matters such as the environmental compatibility of each Renesas Electronics product. You are responsible for carefully and sufficiently investigating applicable laws and regulations that regulate the inclusion or use of controlled substances, including without limitation, the EU RoHS Directive, and using Renesas Electronics products in compliance with all these applicable laws and regulations. Renesas Electronics disclaims any and all liability for damages or losses occurring as a result of your noncompliance with applicable laws and regulations.
  9. Renesas Electronics products and technologies shall not be used for or incorporated into any products or systems whose manufacture, use, or sale is prohibited under any applicable domestic or foreign laws or regulations. You shall comply with any applicable export control laws and regulations promulgated and administered by the governments of any countries asserting jurisdiction over the parties or transactions.
  10. It is the responsibility of the buyer or distributor of Renesas Electronics products, or any other party who distributes, disposes of, or otherwise sells or transfers the product to a third party, to notify such third party in advance of the contents and conditions set forth in this document.
  11. This document shall not be reprinted, reproduced or duplicated in any form, in whole or in part, without prior written consent of Renesas Electronics.
  12. Please contact a Renesas Electronics sales office if you have any questions regarding the information contained in this document or Renesas Electronics products.

(Note1) "Renesas Electronics" as used in this document means Renesas Electronics Corporation and also includes its directly or indirectly controlled subsidiaries.

(Note2) "Renesas Electronics product(s)" means any product developed or manufactured by or for Renesas Electronics.

(Rev.4.0-1 November 2017)

## Corporate Headquarters

TOYOSU FORESIA, 3-2-24 Toyosu,  
Koto-ku, Tokyo 135-0061, Japan  
[www.renesas.com](http://www.renesas.com)

## Trademarks

Renesas and the Renesas logo are trademarks of Renesas Electronics Corporation. All trademarks and registered trademarks are the property of their respective owners.

## Contact information

For further information on a product, technology, the most up-to-date version of a document, or your nearest sales office, please visit:  
[www.renesas.com/contact/](http://www.renesas.com/contact/).