

RX130 Group

R01AN4748EJ0100
Rev.1.00CTSU Application Example: 3D Gesture Demo Set Slim version (Hardware) May 10, 2019

Introduction

The RX130 Group is equipped with hardware (Capacitive Touch Sensor Unit; CTSU) that senses contact of the human body by measuring the capacitance generated between the touch electrode and the human body (hand, etc.).

This application note explains the hardware specifications of the 3D Gesture Demo Set (RTK0EG0016D00001BJ) which is a sample application of the CTSU mutual capacitance method.

Target Device

RX130 Group

Related Documents

1. RX Family CTSU API Reference Guide (R30AN0215EJ)
2. RX Family CTSU Mutual-capacitance Touch Measurement (R30AN0217EJ)
3. RX113 Group CTSU Basis of Cap Touch Detection (R30AN0218EJ)
4. RX Family CTSU 3D Gesture Demo Set Sample Software (R01AN4101EJ)
5. RX231 Group CTSU Application Example: 3D Gesture Demo Set (Hardware) (R01AN4219EJ)
6. RX130 Group CTSU Application Example: 3D Gesture Demo Set Small version(Hardware) (R01AN4320EJ)

Contents

1. Overview	3
2. External Appearance	4
3. Hardware Specification	7
4. Block Diagram	8
5. Circuit Diagram.....	9
6. Board Layouts	10
7. BOM (parts list).....	18
8. EMC Countermeasure Examples.....	20
8.1 Power Input Section Filter.....	20
8.2 Metal Plate Shielding.....	20

1. Overview

The RTK0EG0016D00001BJ is a demonstration kit that detects 3D gesture motion by CTSU of RX130. This demo kit has the following features.

- Small and low profile.
- Simple parts configuration: gesture detection only requires an MCU, electrodes on a substrate pattern, a resistor and a capacitor.
- Quick and easy setup and operation: powered via USB
- Easy-to-use demo (runs with PC demo application)
- Detection distance from about 50 mm.

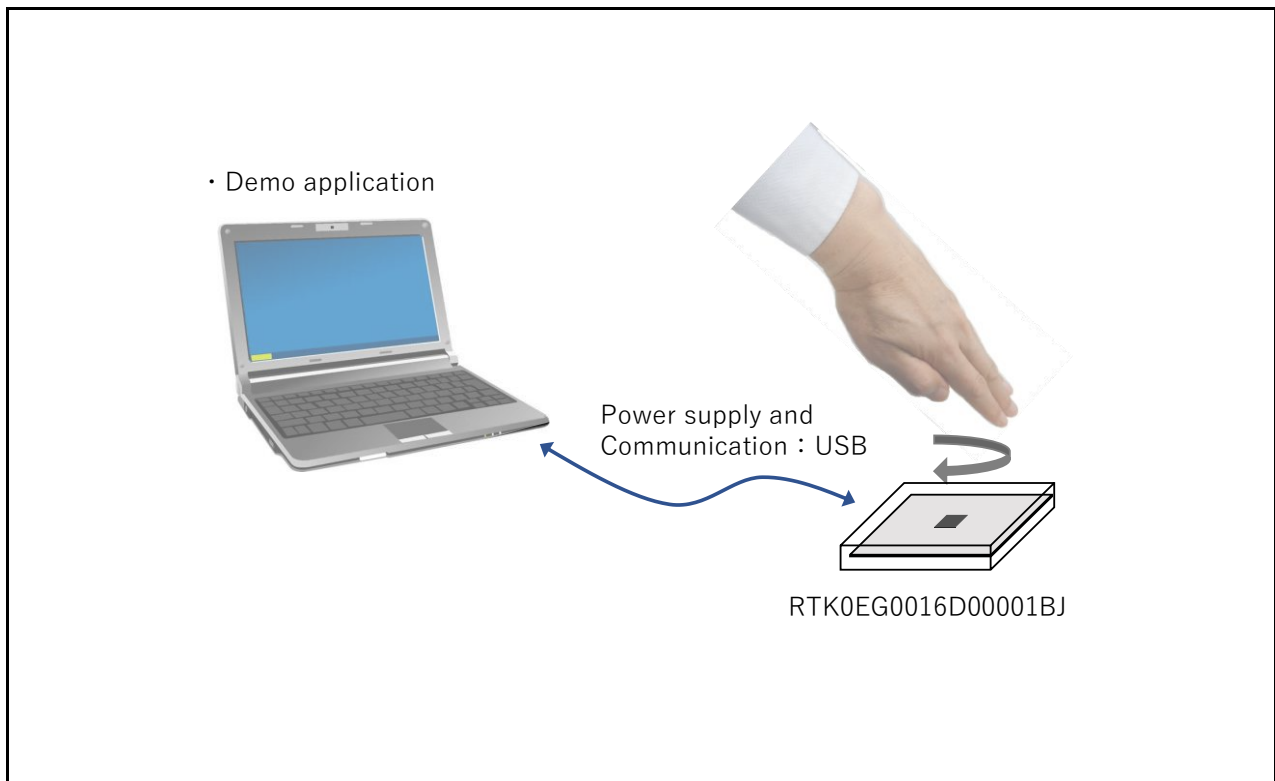

Figure 1-1 3D Gesture Demo System

2. External Appearance

Figure 2-1 to Figure 2-4 show the external appearance and part names related to the 3D Gesture Demo Set.

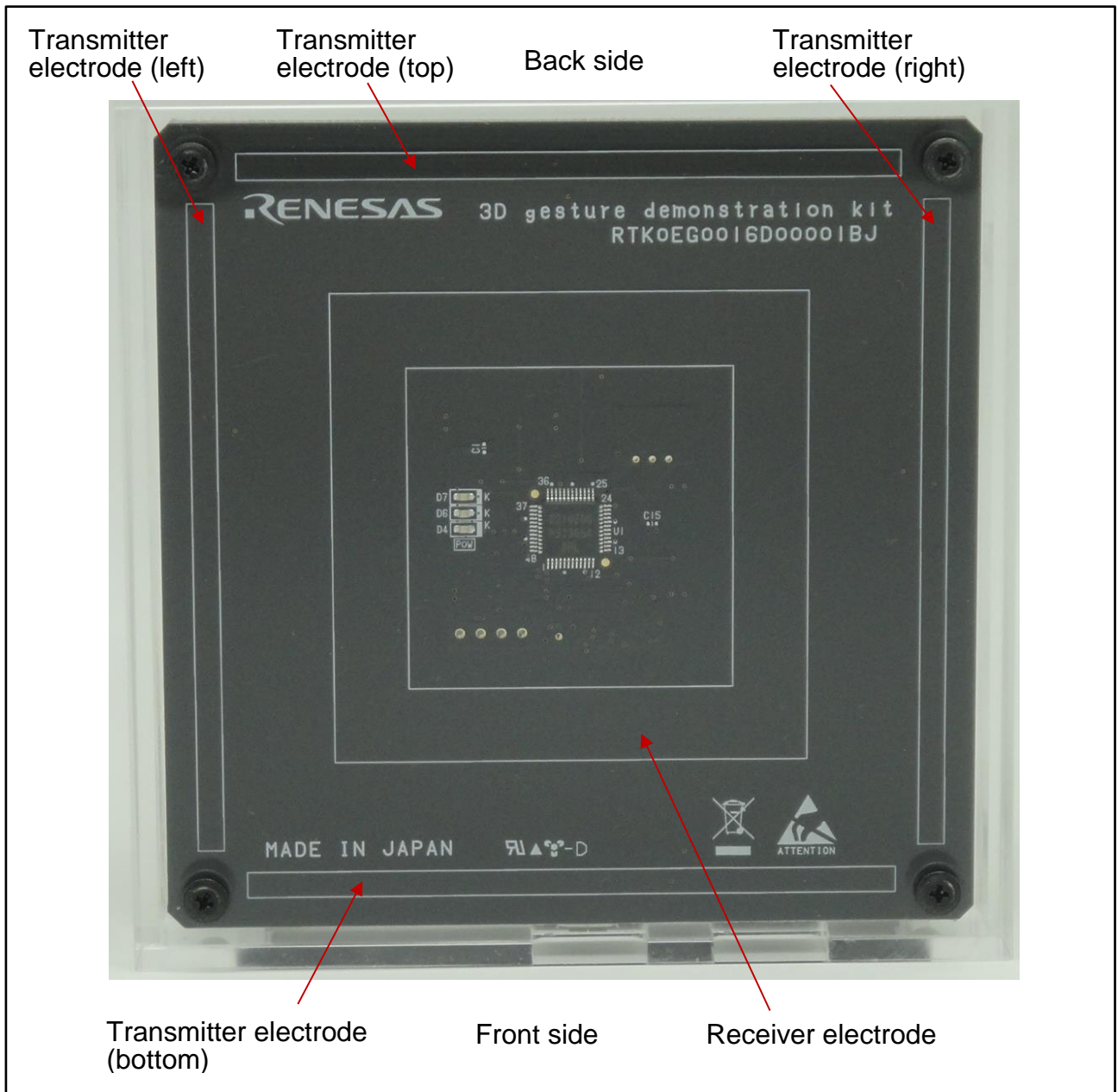

Figure 2-1 External Appearance (top view)

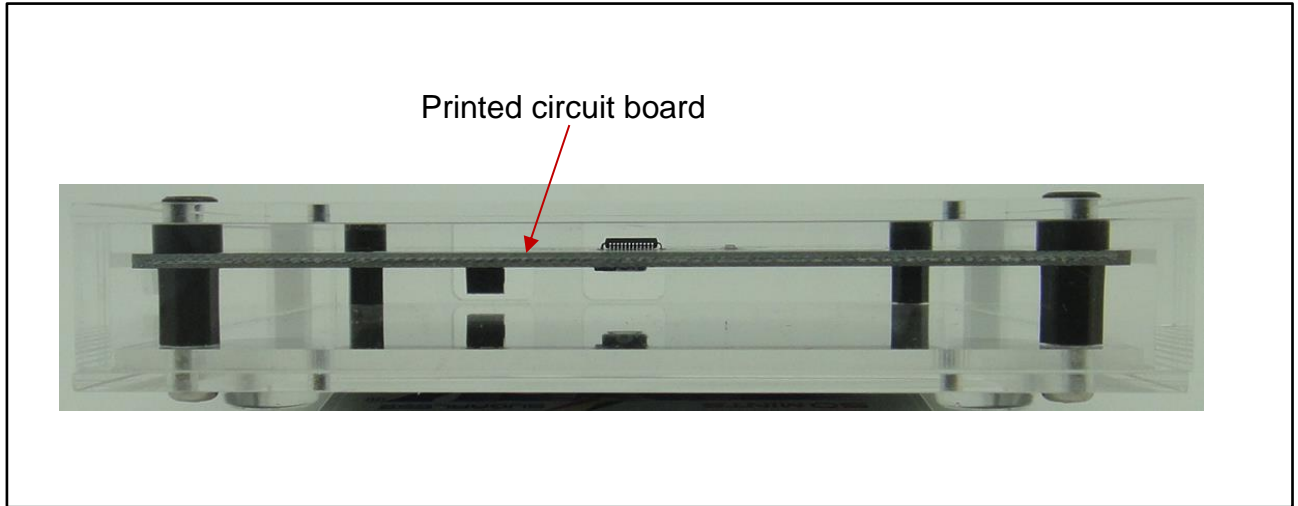

Figure 2-2 External Appearance (front view)

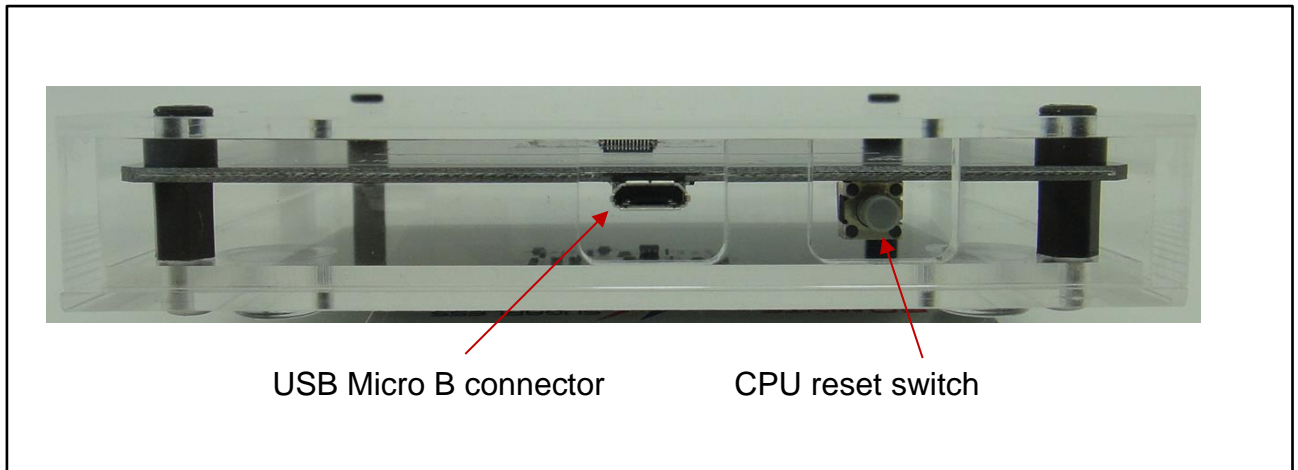

Figure 2-3 External Appearance (back view)

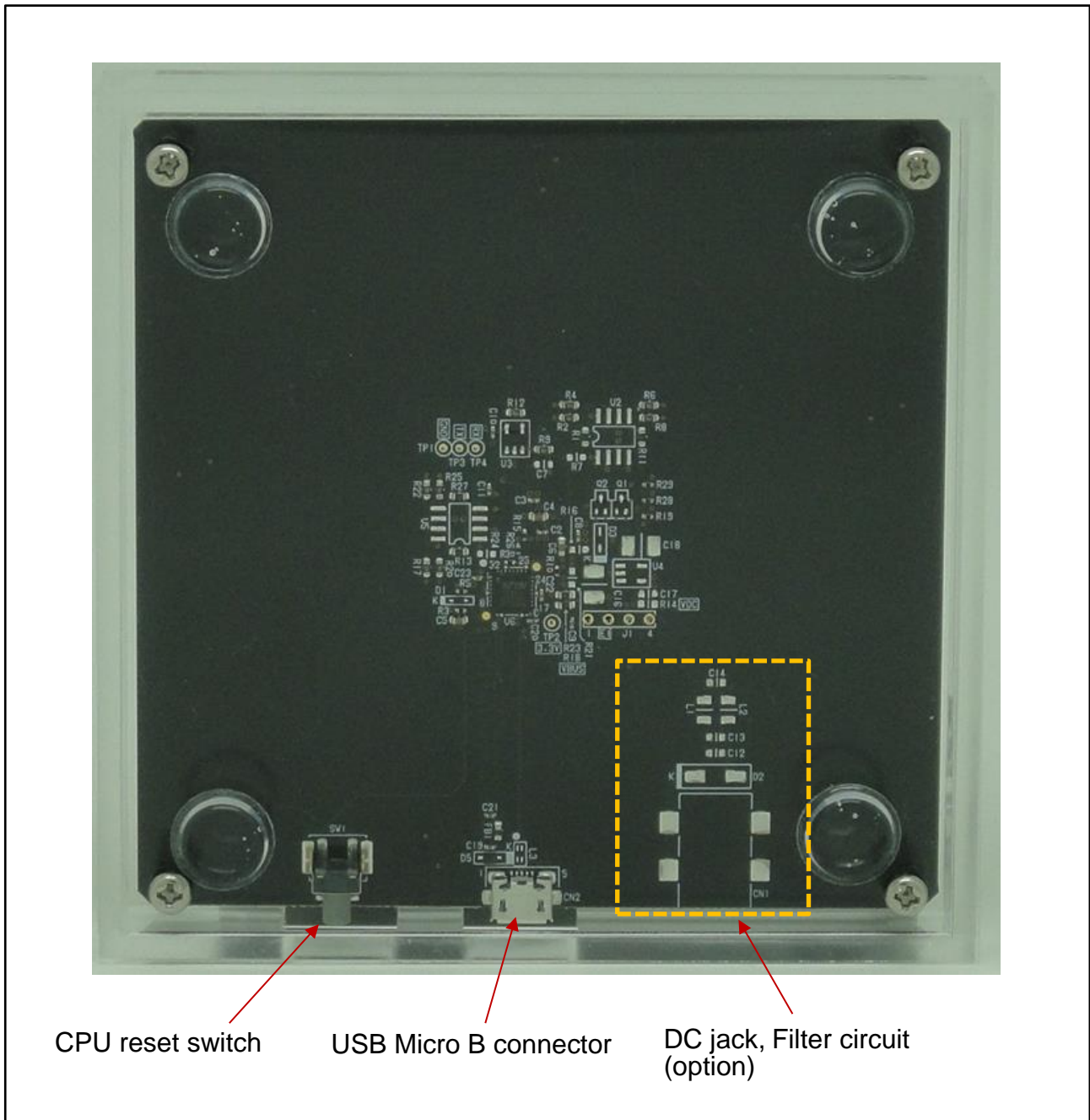

Figure 2-4 External Appearance (bottom view)

3. Hardware Specification

Table 3-1 Hardware Specification

Item	Description	Notes
Board size	100.0×100.0[mm]	
CPU	RX130 (R5F51305ADFL)	ROM: 128KB RAM: 16KB Data flash: 8KB Package: 48-pin LQFP (0.5mm pitch) Operating ambient temperature: -40~85°C
Clock input	On-chip oscillator	
LEDs	Power supply: 1 orange	
	Function display: 1 orange, 1 green	CPU port control
Switch	Push switch: 1	CPU reset switch
Gesture detection electrodes	Receiver electrode: 1	
	Transmitter electrode: 4	Top, bottom, left, right
USB serial conversion interface	Connector: USB Micro B	
	IC: FTDI's FT232RL	Full-speed transfer
Debug interface	E1 connection through hole	
Power supply	USB bus powered (VBUS): 5 V	
	Power supply connector (DC jack): 5 V	Φ5.5mm, center plus, option

4. Block Diagram

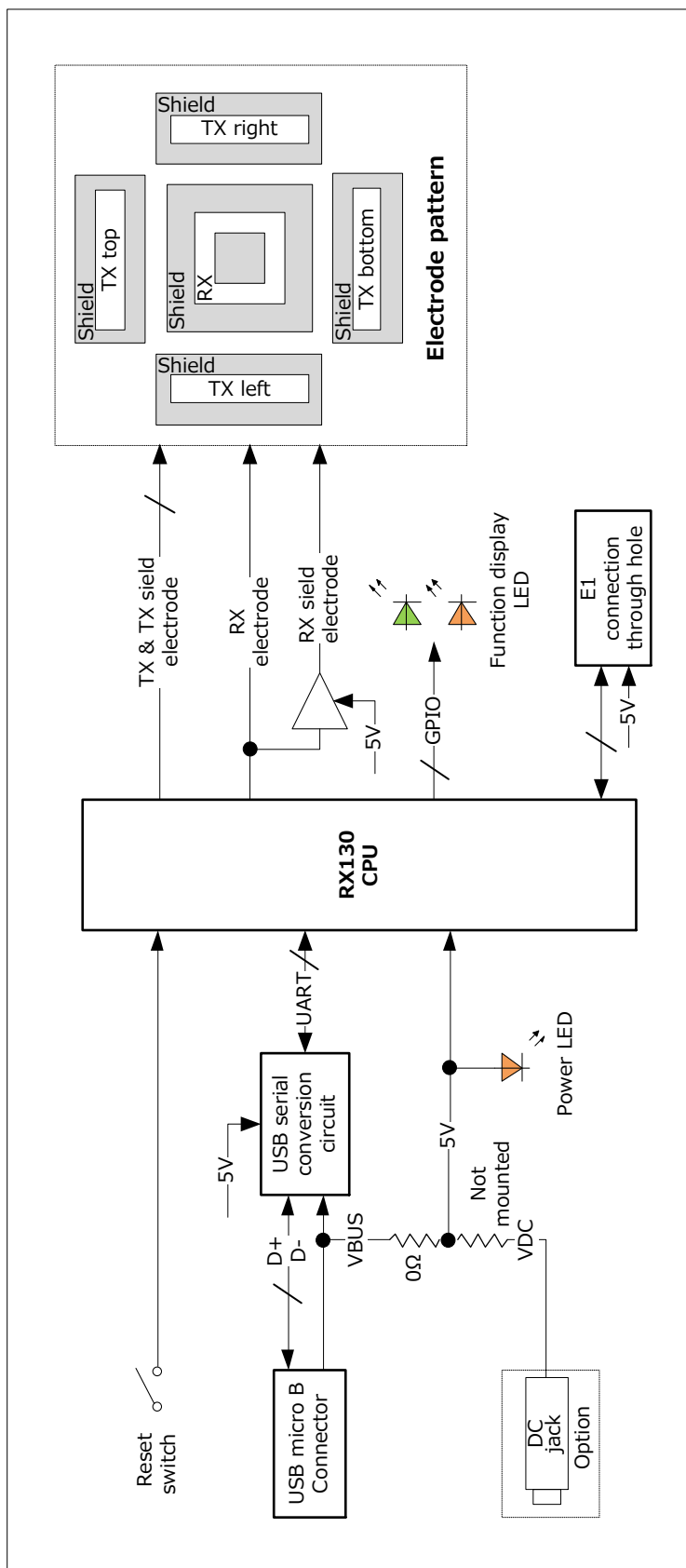

Figure 4-1 Block Diagram

5. Circuit Diagram

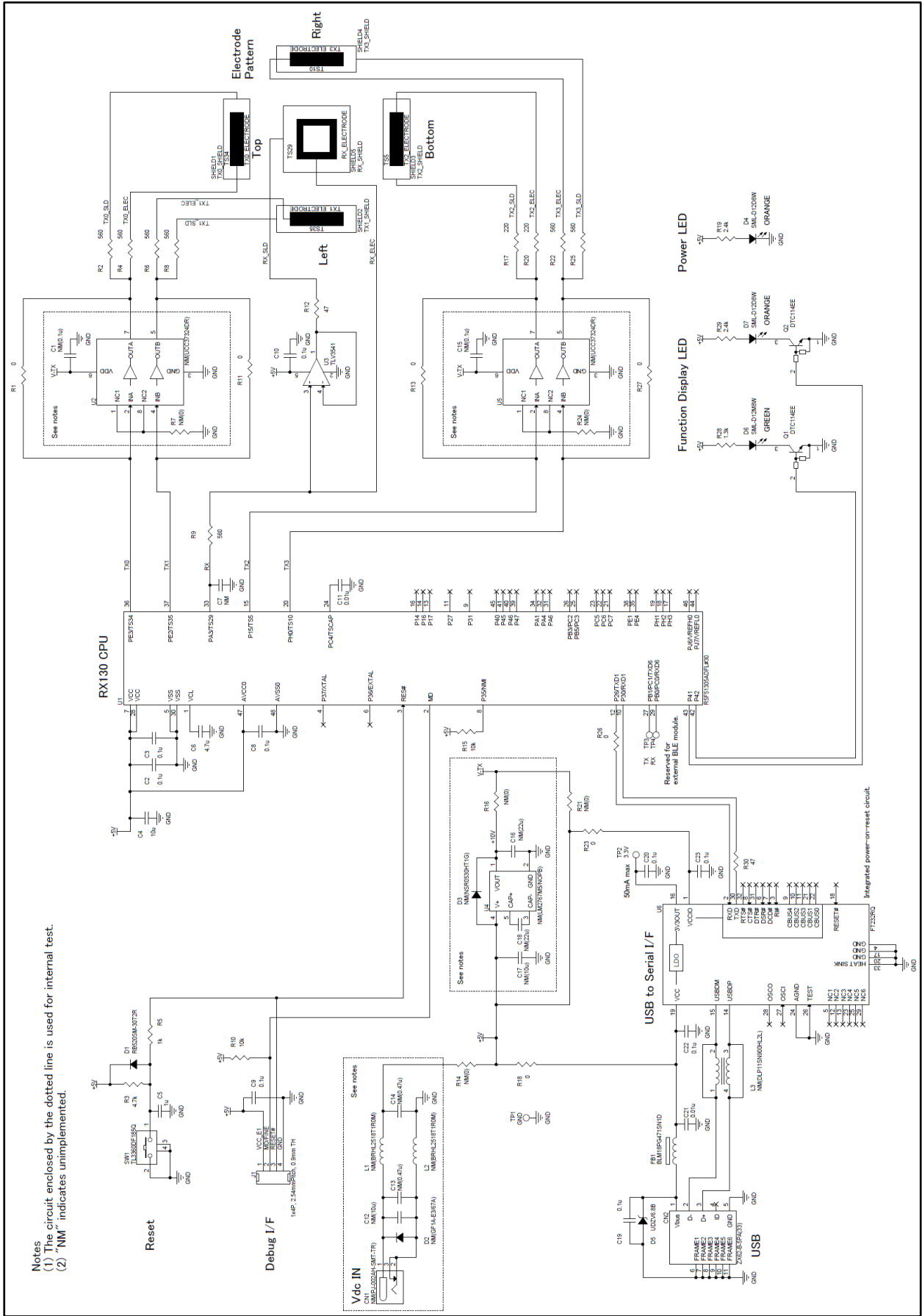

Figure 5-1 Circuit Diagram

6. Board Layouts

Figure 6-1 to Figure 6-8 show the board layout (top view) related to the 3D Gesture Demo Set.

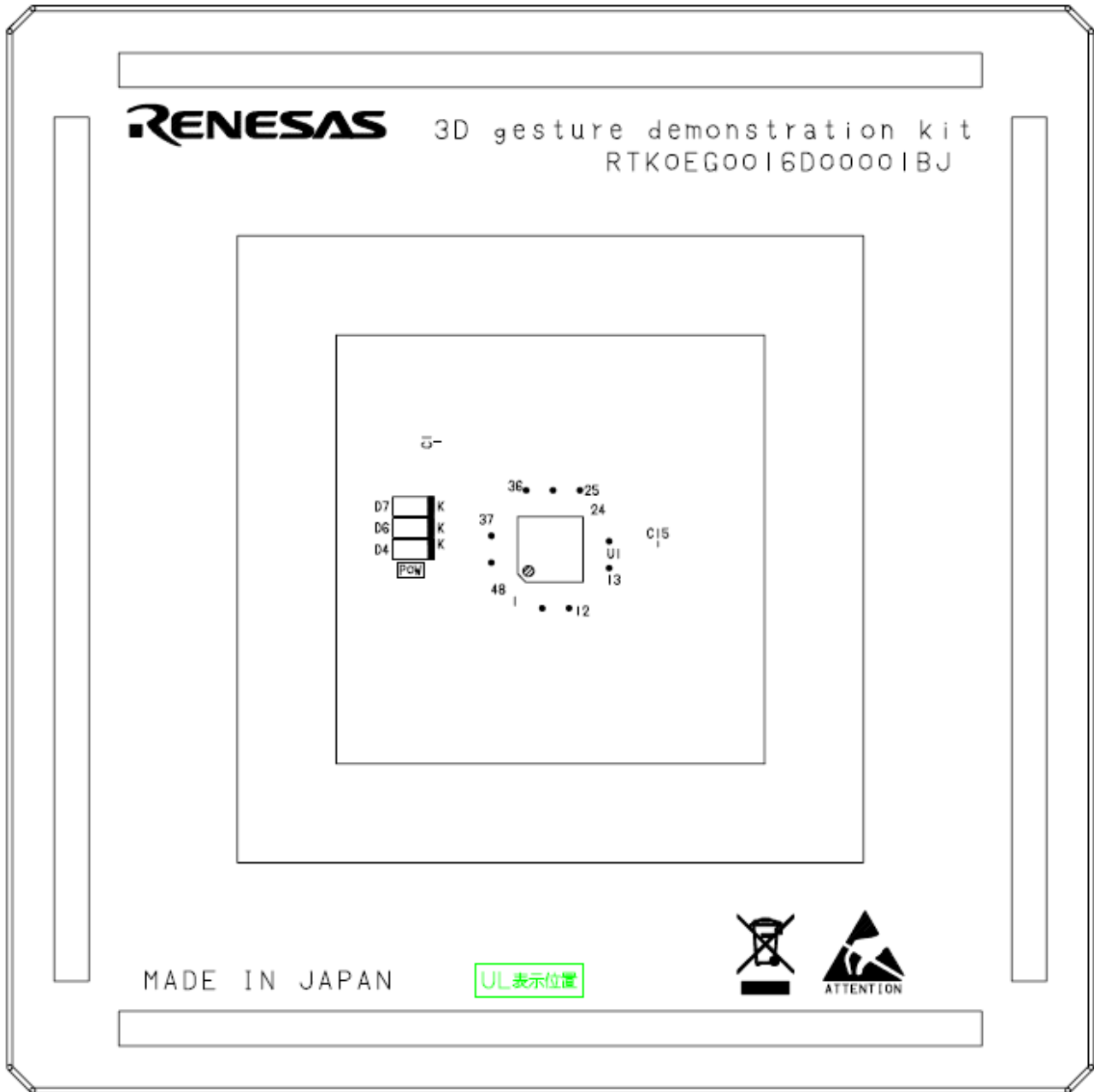
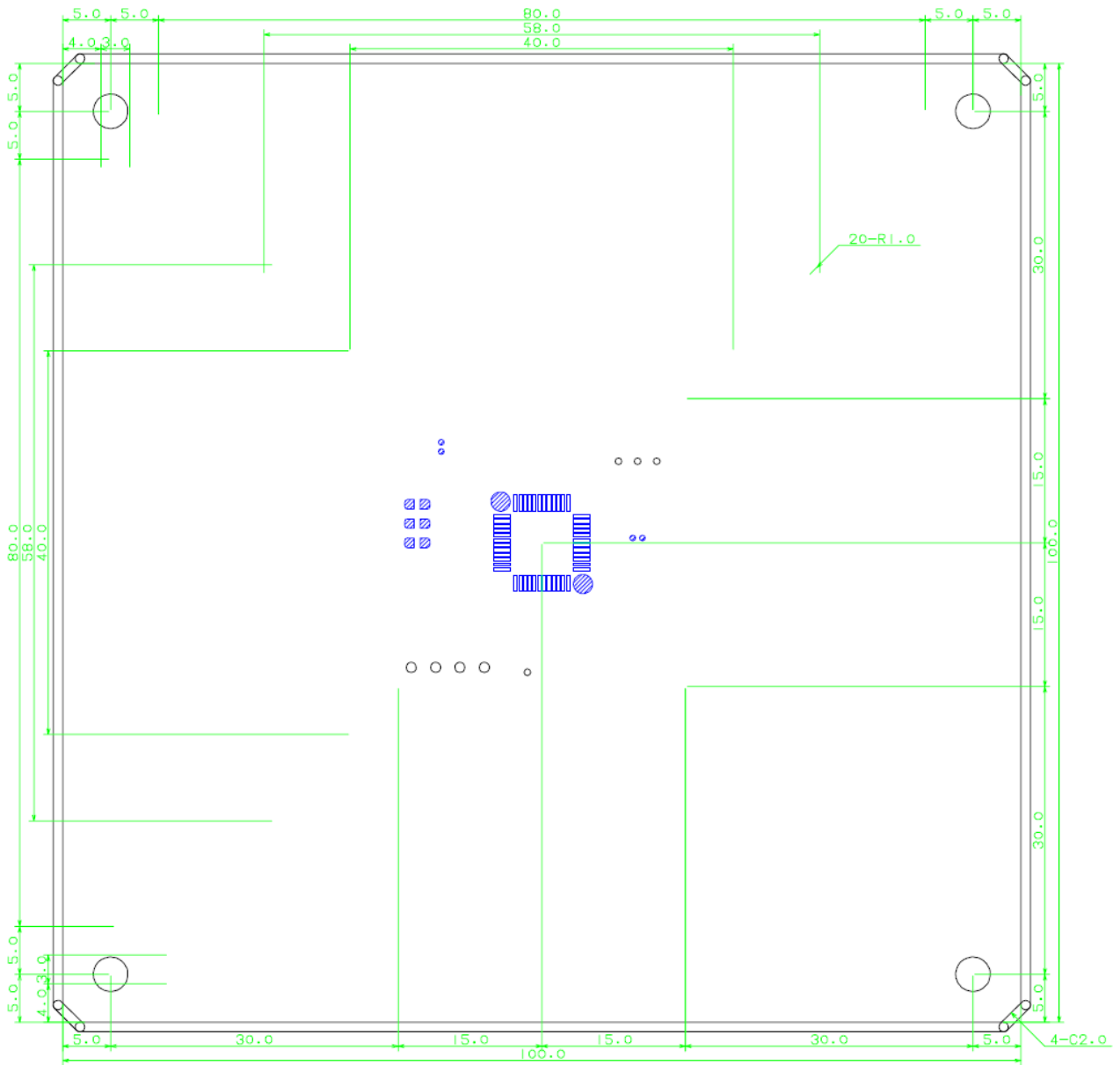
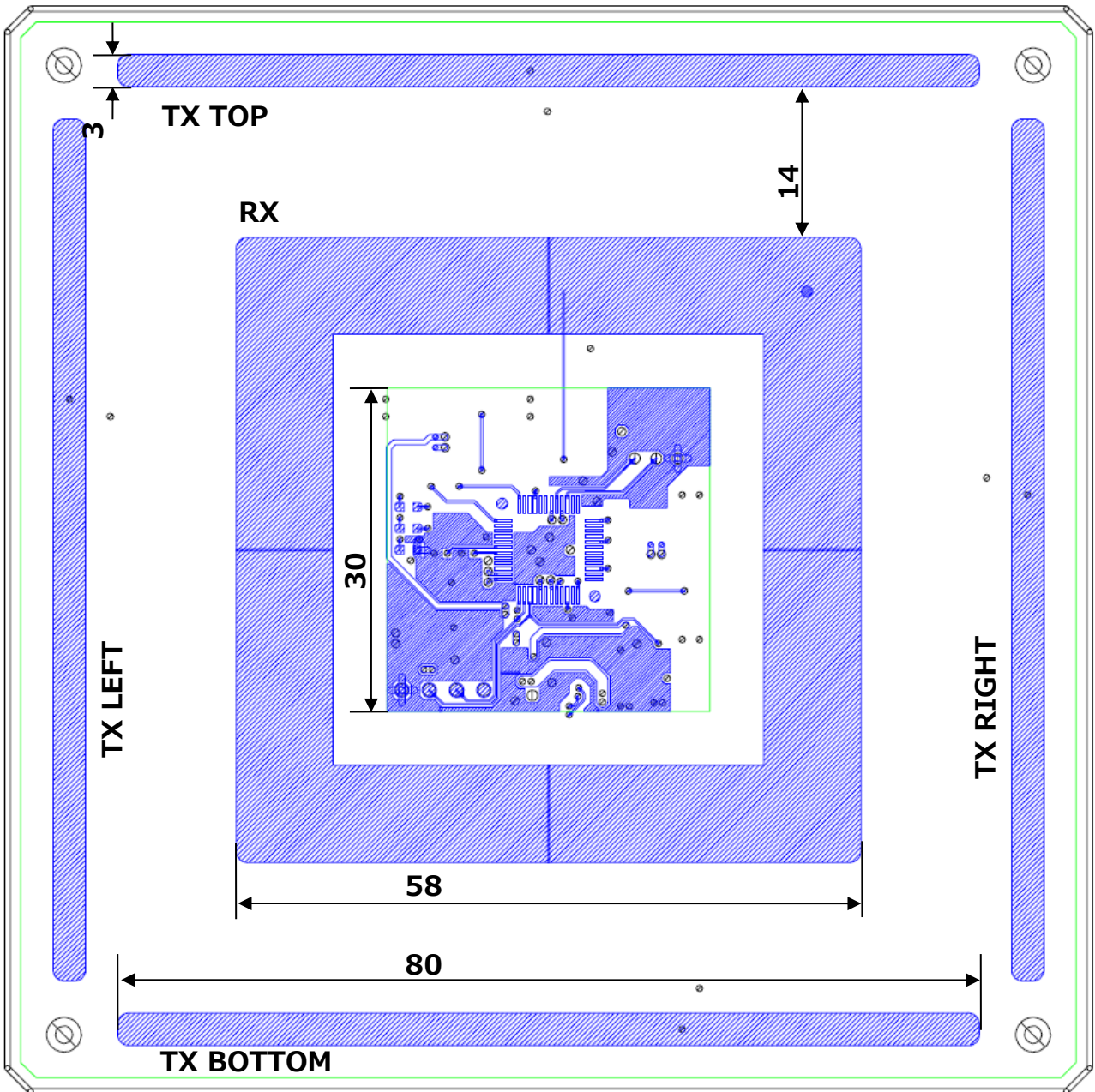

Figure 6-1 Component Side Silkscreen



Unit: mm

Figure 6-2 Component Side Solder Mask



Unit: mm

Figure 6-3 1st Layer Pattern

The 4 TX and RX electrodes are all copper solid patterns.

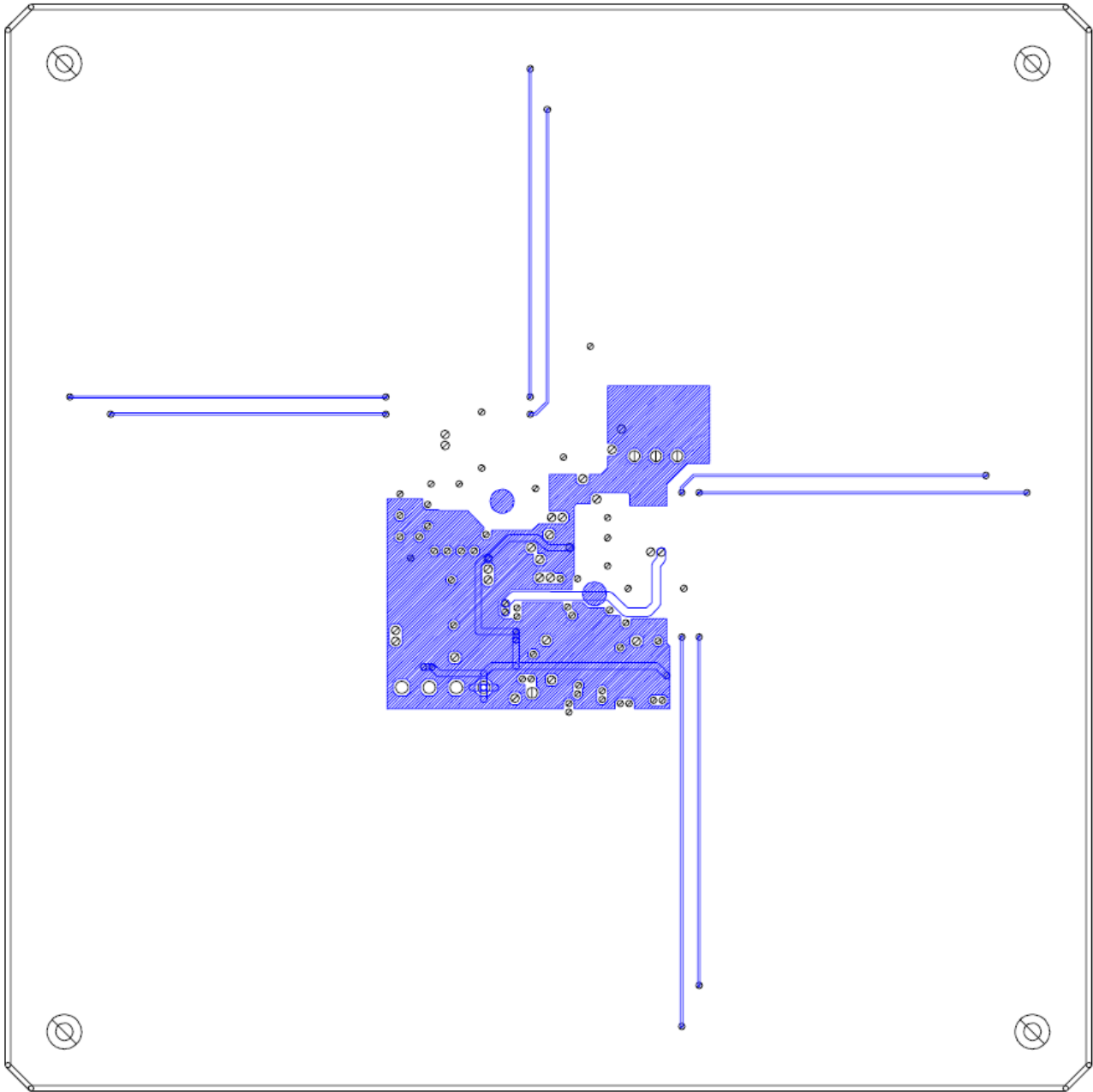
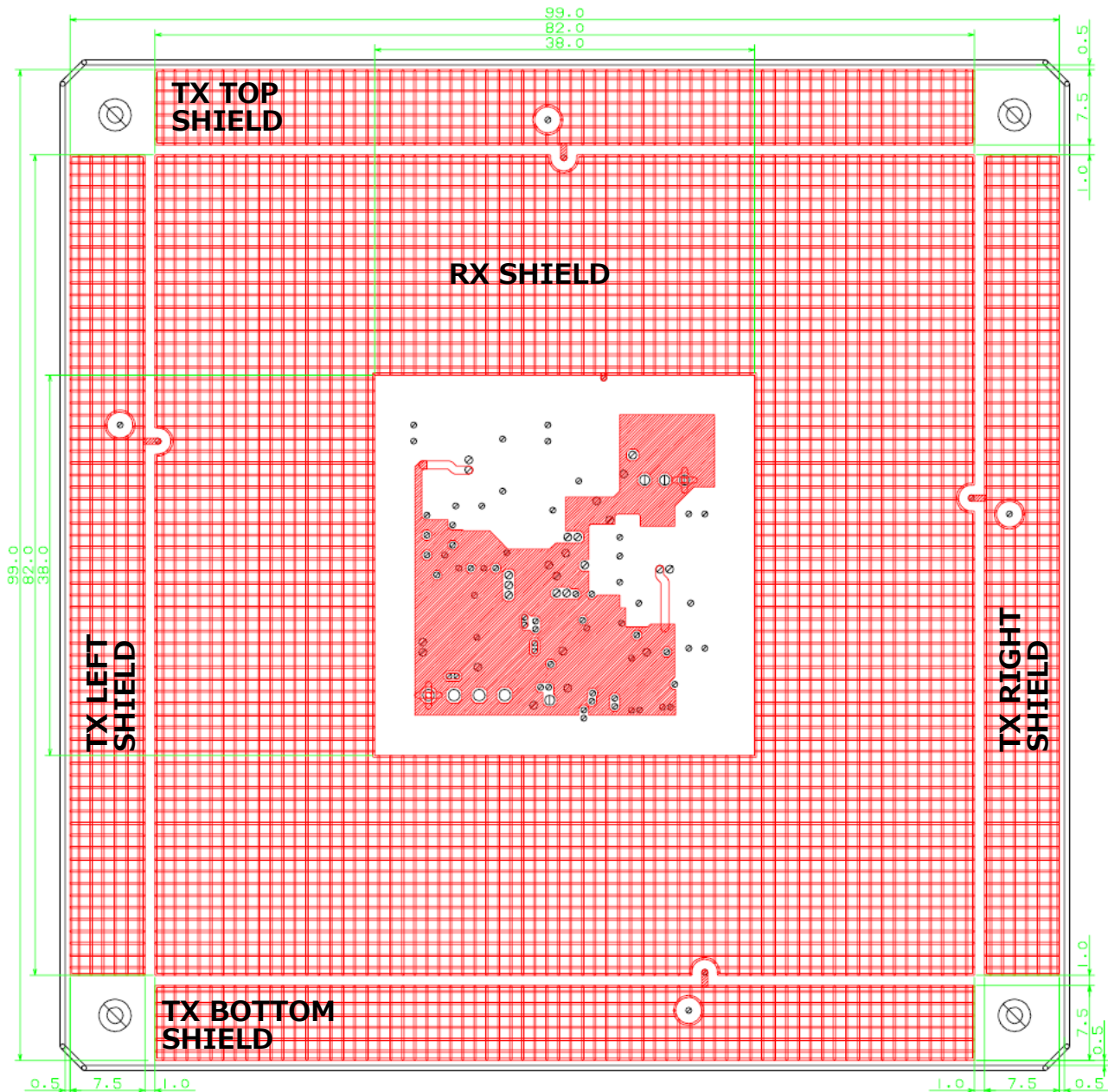

Figure 6-4 2nd Layer Pattern



Unit: mm

Figure 6-5 3rd Layer Pattern

The shield electrodes are a mesh pattern with a copper to blank ratio of 3 to 7.

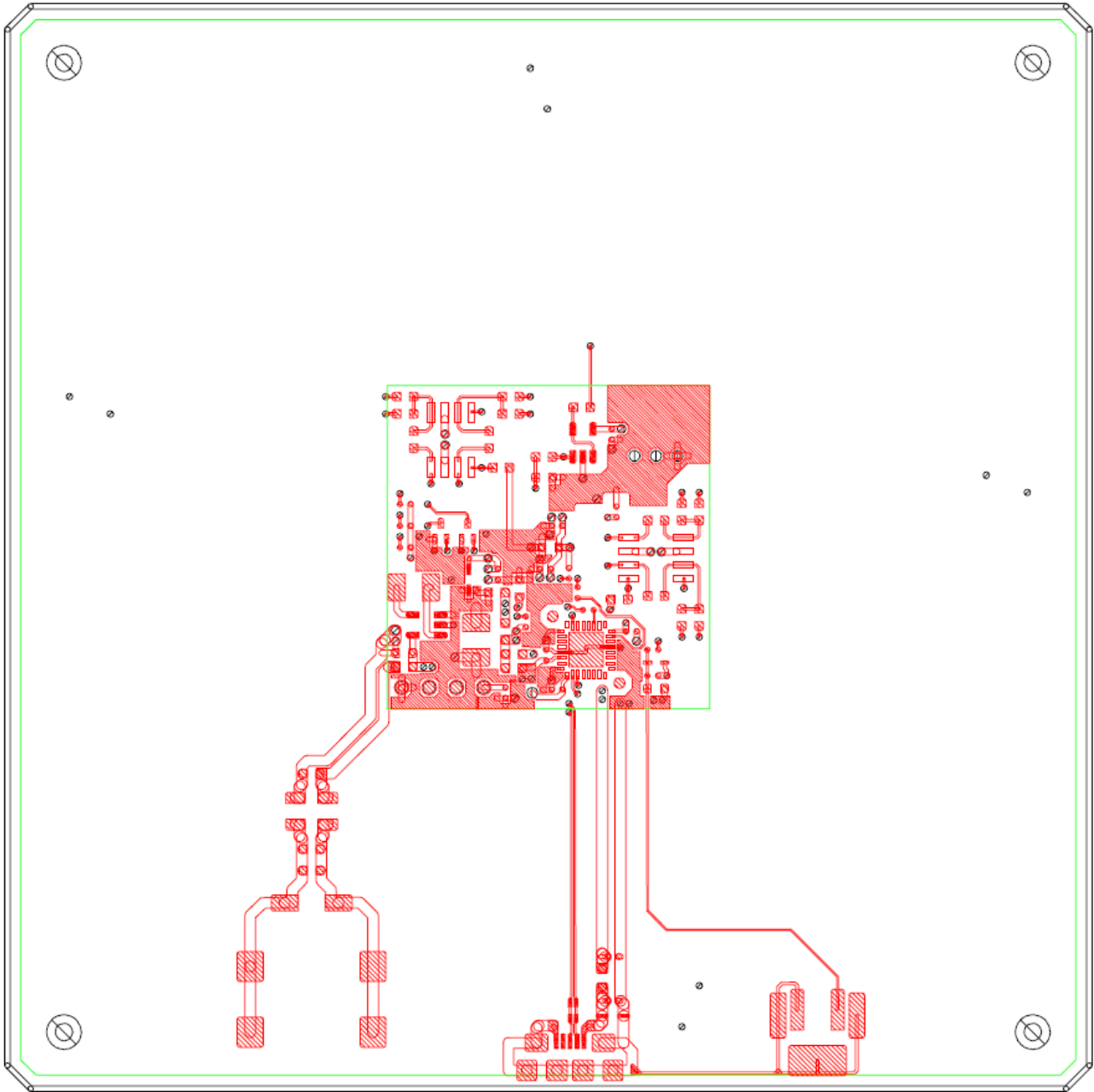

Figure 6-6 Solder Side Pattern

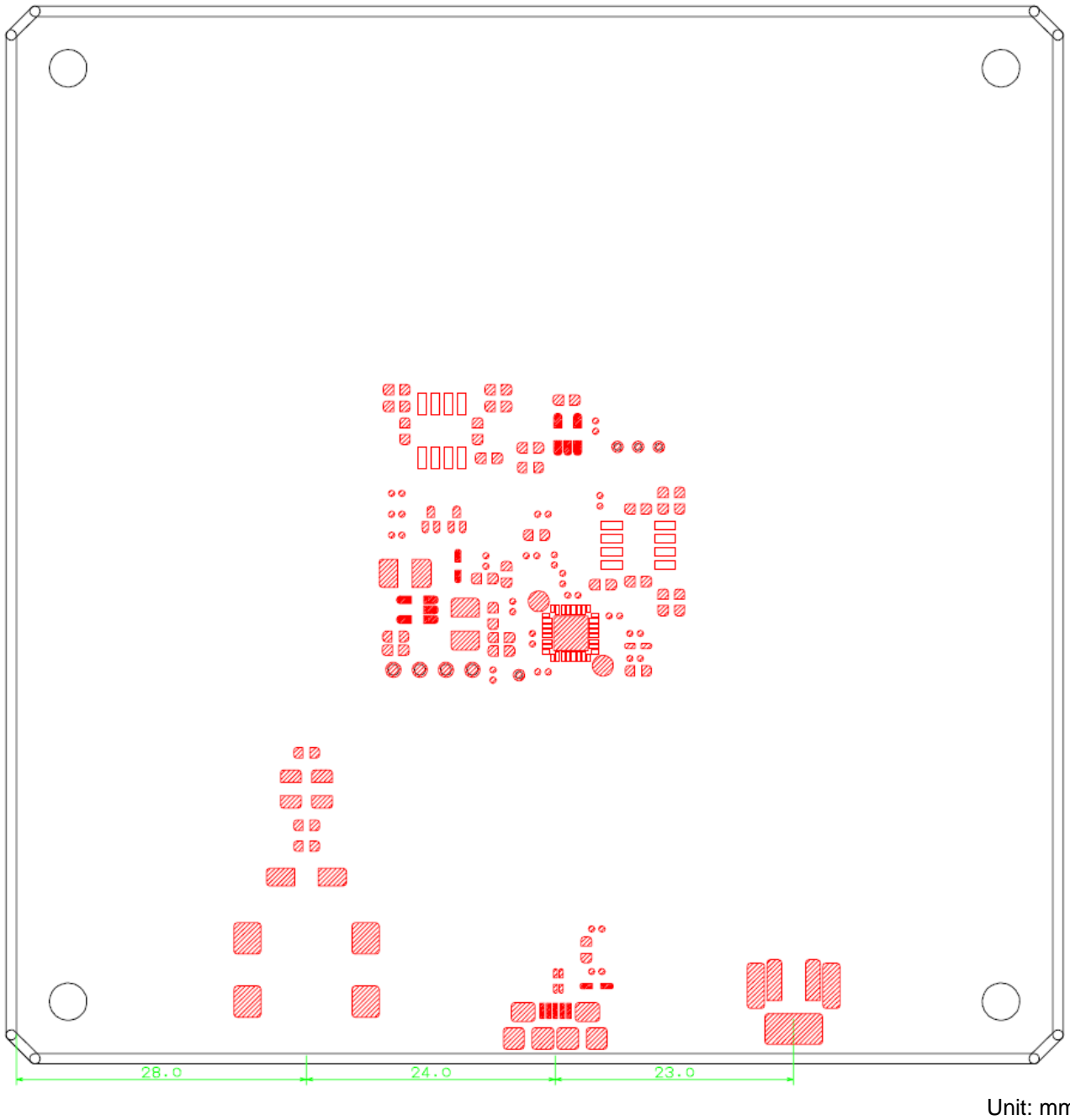

Figure 6-7 Solder Side Solder Mask

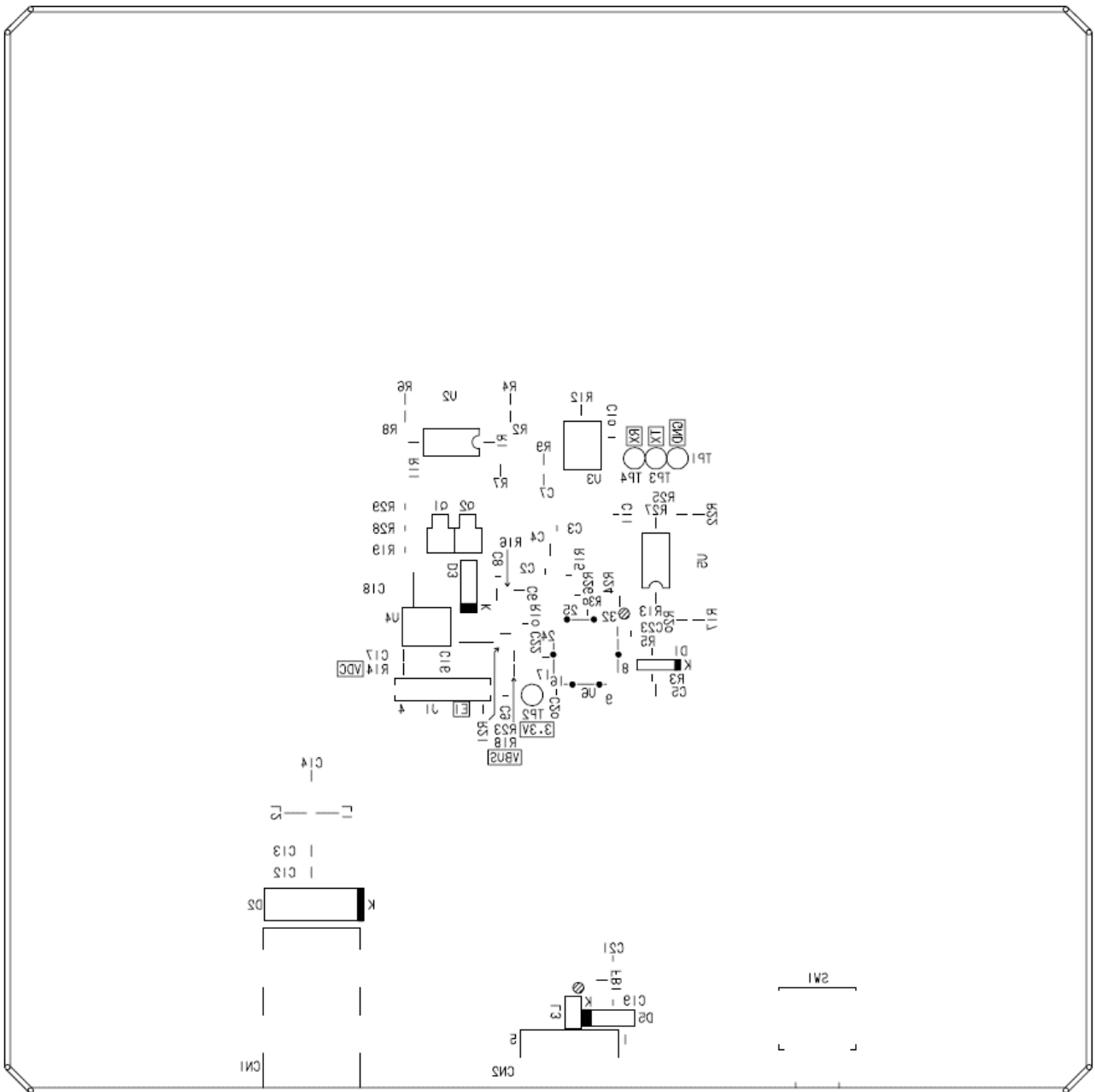

Figure 6-8 Solder Side Silkscreen

7. BOM (parts list)

Table 7-1 BOM (1/2)

Item	Parts Type	Reference	Part Number	Manufacture	Mount/ UnMount	Qty	Remarks
1	DC Jack	CN1	PJ-002AH-SMT-TR	CUI	UnMount	1	No boss hole on the board is required.
2	USB Connector	CN2	ZX62-B-5PA(33)	HIROSE	Mount	1	Micro-B, SMD, Right Angle, Non-reverse type
3	Ceramic Capacitor	C1,C15	GCM155R71H104K E02D	MURATA	UnMount	2	0.1uF, 10%, 50V, X7R, 0402"(1005mm).
4	Ceramic Capacitor	C2,C3,C8,C9,C10,C19,C20,C22,C23	GCM155R71H104K E02D	MURATA	Mount	9	0.1uF, 10%, 50V, X7R, 0402"(1005mm).
5	Ceramic Capacitor	C4	GRM188R61C106 MA73D	MURATA	Mount	1	10uF, 20%, 16V, X5R, 0603"(1608mm)
6	Ceramic Capacitor	C5	GCM188R71E105K A64D	MURATA	Mount	1	1uF, 10%, 25V, X7R, 0603"(1608mm).
7	Ceramic Capacitor	C6	GRM188R61E475K E11D	MURATA	Mount	1	4.7uF, 10%, 25V, X5R, 0603"(1608mm)
8	Ceramic Capacitor	C7	-	-	UnMount	1	0603"(1608mm) CAP PAD
9	Ceramic Capacitor	C11,C21	GCM155R71H103K A55D	MURATA	Mount	2	0.01uF, 10%, 50V, X7R, 0402"(1005mm).
10	Ceramic Capacitor	C12,C17	GRM188R61C106 MA73D	MURATA	UnMount	2	10uF, 20%, 16V, X5R, 0603"(1608mm)
11	Ceramic Capacitor	C13,C14	GCM188R71E474K A64D	MURATA	UnMount	2	0.47uF, 10%, 25V, X7R, 0603"(1608mm)
12	Ceramic Capacitor	C16,C18	CGA6P1X7R1C226 M	TDK	UnMount	2	22uF, 20%, 16V, X7R 1210"(3225mm)
13	Diode Schottky	D1	RB520SM-30T2R	ROHM	Mount	1	30V, 200mA, EMD2
14	Diode	D2	GF1A-E3/67A	Vishay	UnMount	1	50V, 1A, DO-214BA
15	Diode Schottky	D3	NSR0530HT1G	ON Semiconductor	UnMount	1	30V, 500mA, SOD-323
16	LED	D4,D7	SML-D12D8WT86	ROHM	Mount	2	Orange, 0603"(1608mm)
17	DIODE ZENER	D5	UDZVTE-176.8B	ROHM	Mount	1	6.8V, 200mW, UMD2
18	LED	D6	SML-D12M8WT86	ROHM	Mount	1	Green, 0603"(1608mm)
19	Ferrite Beads	FB1	BLM18PG471SN1D	MURATA	Mount	1	470 ohm, 0603"(1608mm)
20	Connector	J1	-	-	-	1	1x4P, 2.54mmPitch, 0.9mm TH
21	Inductor	L1,L2	BRHL2518T1R0M	Taiyo Yuden	UnMount	2	1uH, 1.4A, 71.5 mOhm, 1007"(2518mm)
22	Inductor	L3	DLP11SN900HL2L	MURATA	UnMount	1	COMMON MODE CHOKE, 150mA, 90ohm, SMD
23	Digital Transistor	Q1,Q2	DTC114EETL	ROHM	Mount	2	50V, 50mA, 150mW, EMT3
24	Chip Resistor	R1,R11,R13,R18,R23,R27	MCR03EZPJ000	ROHM	Mount	6	0 ohm, 5%, 1/10W, 0603"(1608mm)
25	Chip Resistor	R2,R4,R6,R8,R9,R22,R25	MCR03EZPJ561	ROHM	Mount	7	560 ohm, 5%, 1/10W, 0603"(1608mm)
26	Chip Resistor	R3	MCR01MZPJ472	ROHM	Mount	1	4.7kohm, 5%, 1/16W, 0402"(1005mm)
27	Chip Resistor	R5	MCR01MZPJ102	ROHM	Mount	1	1k ohm, 5%, 1/16W, 0402"(1005mm)

Table 7-2 BOM (2/2)

Item	Parts Type	Reference	Part Number	Manufacture	Mount/ UnMount	Qty	Remarks
28	Chip Resistor	R7,R14,R16,R21,R24	MCR03EZPJ000	ROHM	UnMount	5	0 ohm, 5%, 1/10W, 0603"(1608mm)
29	Chip Resistor	R10,R15	MCR01MZPJ103	ROHM	Mount	2	10k ohm, 5%, 1/16W, 0402"(1005mm)
30	Chip Resistor	R12	MCR03EZPJ470	ROHM	Mount	1	47 ohm, 5%, 1/10W, 0603"(1608mm).
31	Chip Resistor	R17,R20	MCR03EZPJ221	ROHM	Mount	2	220 ohm, 5%, 1/10W, 0603"(1608mm)
32	Chip Resistor	R19,R29	MCR01MZPJ242	ROHM	Mount	2	2.4k ohm, 5%, 1/16W, 0402"(1005mm)
33	Chip Resistor	R26	MCR01MZPJ000	ROHM	Mount	1	0 ohm, 5%, 1/16W, 0402"(1005mm)
34	Chip Resistor	R28	MCR01MZPJ132	ROHM	Mount	1	1.3k ohm, 5%, 1/16W, 0402"(1005mm)
35	Chip Resistor	R30	MCR01MZPJ470	ROHM	Mount	1	47 ohm, 5%, 1/16W, 0402"(1005mm).
36	Shield Pattern	SHIELD1	-	-	-	1	TX0(Top) shield pattern
37	Shield Pattern	SHIELD2	-	-	-	1	TX1(Left) shield pattern
38	Shield Pattern	SHIELD3	-	-	-	1	TX2(Bottom) shield pattern
39	Shield Pattern	SHIELD4	-	-	-	1	TX3(Right) shield pattern
40	Shield Pattern	SHIELD5	-	-	-	1	RX shield pattern
41	Tactile Switch	SW1	TL3360DF185Q	E-Switch	Mount	1	SPST-NO, Surface Mount, Right Angle
42	Test Point	TP1	-	-	-	1	0.5mm DIA TH, SILK"GND"
43	Test Point	TP2	-	-	-	1	0.5mm DIA TH, SILK"3.3V"
44	Test Point	TP3	-	-	-	1	0.5mm DIA TH, SILK"TX"
45	Test Point	TP4	-	-	-	1	0.5mm DIA TH, SILK"RX"
46	Electrode Pattern	TS5	-	-	-	1	TX2(Bottom) Electrode Pattern
47	Electrode Pattern	TS10	-	-	-	1	TX3(Right) Electrode Pattern
48	Electrode Pattern	TS29	-	-	-	1	RX Electrode Pattern
49	Electrode Pattern	TS34	-	-	-	1	TX0(Top) Electrode Pattern
50	Electrode Pattern	TS35	-	-	-	1	TX1(Left) Electrode Pattern
51	IC RX130 MCU	U1	R5F51305ADFL#30	RENESAS	Mount	1	48LQFP
52	IC GATE DRIVER	U2,U5	UCC37324DR	Texas Instruments	UnMount	2	DUAL, 8SOIC
53	IC OP AMP	U3	TLV3541IDBVT	Texas Instruments	Mount	1	Rail-to-Rail, SOT23-5
54	IC REGULAT OR	U4	LM2767M5/NOPB	Texas Instruments	UnMount	1	Charge Pump, SOT-23
55	IC Interface	U6	FT232RQ	FTDI	Mount	1	USB to Serial UART, 32-QFN
56	PCB	-	RTK0EG0016D00001BJ	-	-	1	

NM indicates "not mounted."

8. EMC Countermeasure Examples

Detection of 3D gestures uses linear data sampled at regular time intervals. Therefore, unlike switches that only judge two values, i.e. ON/OFF, EMC countermeasures for 3D detection is difficult because a noise margin cannot be secured.

In this demo set, noise countermeasures are implemented from both hardware and software standpoints. This document describes examples of hardware-based countermeasures.

Required noise immunity and countermeasures differ depending on user system specifications. The countermeasures shown here are just a few examples and may not be applicable to all systems. When implementing countermeasures, please carry out thorough evaluations on your product system.

8.1 Power Input Section Filter

The filter circuit shown in Figure 8-1 is added to the demo set to suppress noise input and output from the power cable.

8.2 Metal Plate Shielding

The demo set is shielded with the metal plate shown in Figure 8-1 to improve the coupling between the ground (earth) and the CPU board GND, as well as strengthen the GND.

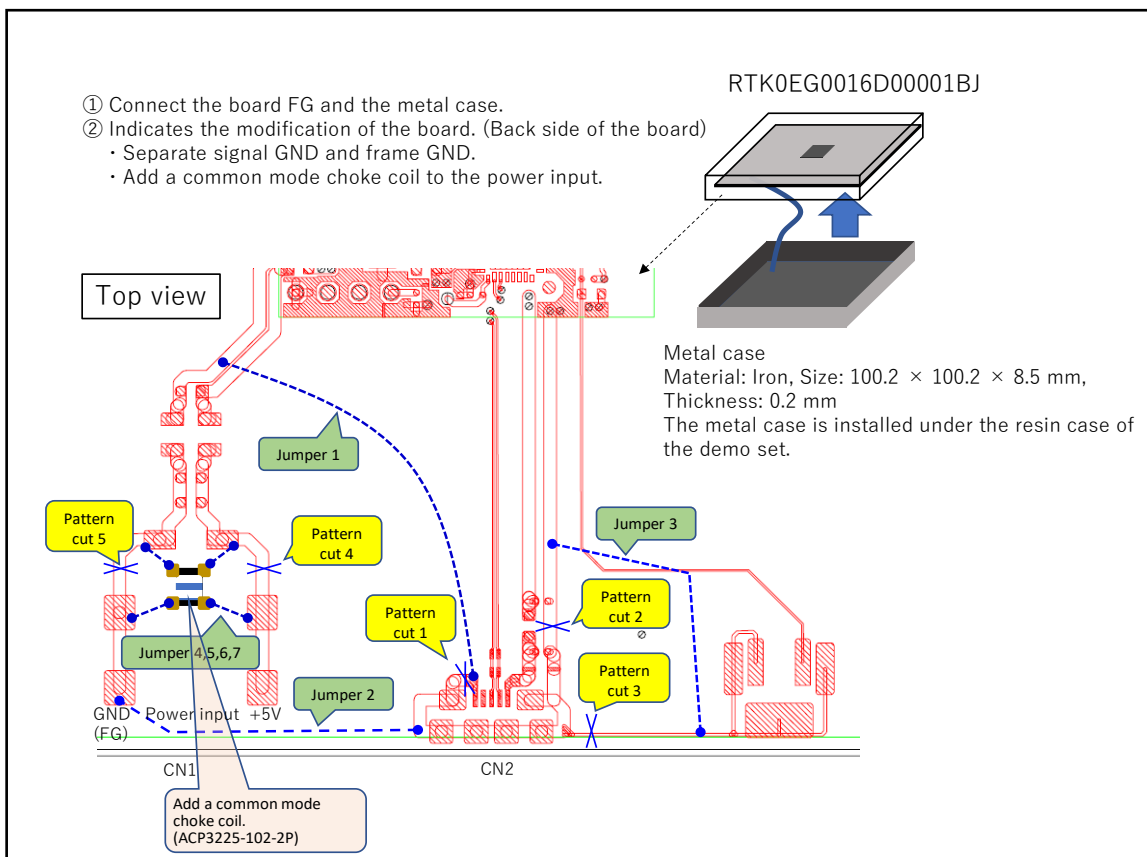

Figure 8-1 EMC Countermeasure Example

Website and Support

Renesas Electronics Website

<http://www.renesas.com/>

Inquiries

<http://www.renesas.com/contact/>

All trademarks and registered trademarks are the property of their respective owners.

Revision History

Rev.	Date	Description	
		Page	Summary
1.00	May 10, 2018	-	First edition issued

General Precautions in the Handling of Microprocessing Unit and Microcontroller Unit Products

The following usage notes are applicable to all Microprocessing unit and Microcontroller unit products from Renesas. For detailed usage notes on the products covered by this document, refer to the relevant sections of the document as well as any technical updates that have been issued for the products.

1. Precaution against Electrostatic Discharge (ESD)

A strong electrical field, when exposed to a CMOS device, can cause destruction of the gate oxide and ultimately degrade the device operation. Steps must be taken to stop the generation of static electricity as much as possible, and quickly dissipate it when it occurs. Environmental control must be adequate. When it is dry, a humidifier should be used. This is recommended to avoid using insulators that can easily build up static electricity.

Semiconductor devices must be stored and transported in an anti-static container, static shielding bag or conductive material. All test and measurement tools including work benches and floors must be grounded. The operator must also be grounded using a wrist strap. Semiconductor devices must not be touched with bare hands. Similar precautions must be taken for printed circuit boards with mounted semiconductor devices.

2. Processing at power-on

The state of the product is undefined at the time when power is supplied. The states of internal circuits in the LSI are indeterminate and the states of register settings and pins are undefined at the time when power is supplied. In a finished product where the reset signal is applied to the external reset pin, the states of pins are not guaranteed from the time when power is supplied until the reset process is completed. In a similar way, the states of pins in a product that is reset by an on-chip power-on reset function are not guaranteed from the time when power is supplied until the power reaches the level at which resetting is specified.

3. Input of signal during power-off state

Do not input signals or an I/O pull-up power supply while the device is powered off. The current injection that results from input of such a signal or I/O pull-up power supply may cause malfunction and the abnormal current that passes in the device at this time may cause degradation of internal elements. Follow the guideline for input signal during power-off state as described in your product documentation.

4. Handling of unused pins

Handle unused pins in accordance with the directions given under handling of unused pins in the manual. The input pins of CMOS products are generally in the high-impedance state. In operation with an unused pin in the open-circuit state, extra electromagnetic noise is induced in the vicinity of the LSI, an associated shoot-through current flows internally, and malfunctions occur due to the false recognition of the pin state as an input signal become possible.

5. Clock signals

After applying a reset, only release the reset line after the operating clock signal becomes stable. When switching the clock signal during program execution, wait until the target clock signal is stabilized. When the clock signal is generated with an external resonator or from an external oscillator during a reset, ensure that the reset line is only released after full stabilization of the clock signal. Additionally, when switching to a clock signal produced with an external resonator or by an external oscillator while program execution is in progress, wait until the target clock signal is stable.

6. Voltage application waveform at input pin

Waveform distortion due to input noise or a reflected wave may cause malfunction. If the input of the CMOS device stays in the area between V_{IL} (Max.) and V_{IH} (Min.) due to noise, for example, the device may malfunction. Take care to prevent chattering noise from entering the device when the input level is fixed, and also in the transition period when the input level passes through the area between V_{IL} (Max.) and V_{IH} (Min.).

7. Prohibition of access to reserved addresses

Access to reserved addresses is prohibited. The reserved addresses are provided for possible future expansion of functions. Do not access these addresses as the correct operation of the LSI is not guaranteed.

8. Differences between products

Before changing from one product to another, for example to a product with a different part number, confirm that the change will not lead to problems. The characteristics of a microprocessing unit or microcontroller unit products in the same group but having a different part number might differ in terms of internal memory capacity, layout pattern, and other factors, which can affect the ranges of electrical characteristics, such as characteristic values, operating margins, immunity to noise, and amount of radiated noise. When changing to a product with a different part number, implement a system-evaluation test for the given product.

Notice

1. Descriptions of circuits, software and other related information in this document are provided only to illustrate the operation of semiconductor products and application examples. You are fully responsible for the incorporation or any other use of the circuits, software, and information in the design of your product or system. Renesas Electronics disclaims any and all liability for any losses and damages incurred by you or third parties arising from the use of these circuits, software, or information.
2. Renesas Electronics hereby expressly disclaims any warranties against and liability for infringement or any other claims involving patents, copyrights, or other intellectual property rights of third parties, by or arising from the use of Renesas Electronics products or technical information described in this document, including but not limited to, the product data, drawings, charts, programs, algorithms, and application examples.
3. No license, express, implied or otherwise, is granted hereby under any patents, copyrights or other intellectual property rights of Renesas Electronics or others.
4. You shall not alter, modify, copy, or reverse engineer any Renesas Electronics product, whether in whole or in part. Renesas Electronics disclaims any and all liability for any losses or damages incurred by you or third parties arising from such alteration, modification, copying or reverse engineering.
5. Renesas Electronics products are classified according to the following two quality grades: "Standard" and "High Quality". The intended applications for each Renesas Electronics product depends on the product's quality grade, as indicated below.
 - "Standard": Computers; office equipment; communications equipment; test and measurement equipment; audio and visual equipment; home electronic appliances; machine tools; personal electronic equipment; industrial robots; etc.
 - "High Quality": Transportation equipment (automobiles, trains, ships, etc.); traffic control (traffic lights); large-scale communication equipment; key financial terminal systems; safety control equipment; etc.Unless expressly designated as a high reliability product or a product for harsh environments in a Renesas Electronics data sheet or other Renesas Electronics document, Renesas Electronics products are not intended or authorized for use in products or systems that may pose a direct threat to human life or bodily injury (artificial life support devices or systems; surgical implantations; etc.), or may cause serious property damage (space system; undersea repeaters; nuclear power control systems; aircraft control systems; key plant systems; military equipment; etc.). Renesas Electronics disclaims any and all liability for any damages or losses incurred by you or any third parties arising from the use of any Renesas Electronics product that is inconsistent with any Renesas Electronics data sheet, user's manual or other Renesas Electronics document.
6. When using Renesas Electronics products, refer to the latest product information (data sheets, user's manuals, application notes, "General Notes for Handling and Using Semiconductor Devices" in the reliability handbook, etc.), and ensure that usage conditions are within the ranges specified by Renesas Electronics with respect to maximum ratings, operating power supply voltage range, heat dissipation characteristics, installation, etc. Renesas Electronics disclaims any and all liability for any malfunctions, failure or accident arising out of the use of Renesas Electronics products outside of such specified ranges.
7. Although Renesas Electronics endeavors to improve the quality and reliability of Renesas Electronics products, semiconductor products have specific characteristics, such as the occurrence of failure at a certain rate and malfunctions under certain use conditions. Unless designated as a high reliability product or a product for harsh environments in a Renesas Electronics data sheet or other Renesas Electronics document, Renesas Electronics products are not subject to radiation resistance design. You are responsible for implementing safety measures to guard against the possibility of bodily injury, injury or damage caused by fire, and/or danger to the public in the event of a failure or malfunction of Renesas Electronics products, such as safety design for hardware and software, including but not limited to redundancy, fire control and malfunction prevention, appropriate treatment for aging degradation or any other appropriate measures. Because the evaluation of microcomputer software alone is very difficult and impractical, you are responsible for evaluating the safety of the final products or systems manufactured by you.
8. Please contact a Renesas Electronics sales office for details as to environmental matters such as the environmental compatibility of each Renesas Electronics product. You are responsible for carefully and sufficiently investigating applicable laws and regulations that regulate the inclusion or use of controlled substances, including without limitation, the EU RoHS Directive, and using Renesas Electronics products in compliance with all these applicable laws and regulations. Renesas Electronics disclaims any and all liability for damages or losses occurring as a result of your noncompliance with applicable laws and regulations.
9. Renesas Electronics products and technologies shall not be used for or incorporated into any products or systems whose manufacture, use, or sale is prohibited under any applicable domestic or foreign laws or regulations. You shall comply with any applicable export control laws and regulations promulgated and administered by the governments of any countries asserting jurisdiction over the parties or transactions.
10. It is the responsibility of the buyer or distributor of Renesas Electronics products, or any other party who distributes, disposes of, or otherwise sells or transfers the product to a third party, to notify such third party in advance of the contents and conditions set forth in this document.
11. This document shall not be reprinted, reproduced or duplicated in any form, in whole or in part, without prior written consent of Renesas Electronics.
12. Please contact a Renesas Electronics sales office if you have any questions regarding the information contained in this document or Renesas Electronics products.

(Note1) "Renesas Electronics" as used in this document means Renesas Electronics Corporation and also includes its directly or indirectly controlled subsidiaries.

(Note2) "Renesas Electronics product(s)" means any product developed or manufactured by or for Renesas Electronics.

(Rev.4.0-1 November 2017)

Corporate Headquarters

TOYOSU FORESIA, 3-2-24 Toyosu,
Koto-ku, Tokyo 135-0061, Japan
www.renesas.com

Trademarks

Renesas and the Renesas logo are trademarks of Renesas Electronics Corporation. All trademarks and registered trademarks are the property of their respective owners.

Contact information

For further information on a product, technology, the most up-to-date version of a document, or your nearest sales office, please visit:
www.renesas.com/contact/.