

Principles and Applications of the ICL7660 CMOS Voltage Converter

**Introduction**

This application note describes a device originally designed to solve the specific problem of needing a negative supply when only a positive supply is available. This is very common, and occurs, for example, in systems using dynamic RAMs where the three-supply devices require a low current body bias supply of around -5V. Negative supply voltage is also desired in systems with a lot of digital logic (at +5V) but containing a small analog section using A/O converters, such as the ICL7107 or ICL7109 and/or op amps and comparators, operating on ground referenced signals. In all these cases, the current requirement and regulation are not very demanding, but nevertheless, generating such a -5V supply is usually expensive and inefficient. Typically, a large number of discrete and integrated-circuit components are needed to convert the common +5V line into a negative one, or to add an extra output to the main supply, the backplane wiring, etc.

This problem is solved by the ICL7660, a monolithic CMOS power supply circuit offering unique performance advantages over previously available devices. With the addition of only two noncritical capacitors (for charge pump and storage), it performs the complete supply voltage conversion from positive to negative for any input voltage between +1.5V and +10V, and provides the complementary output voltage of -1.5V to -10V. (An additional diode is needed for voltages above 6.5V.) The device operates by charging a pump capacitor to the input supply voltage and then applying the capacitor across the output supply, transferring the necessary charge to an open-circuit storage capacitor.

The ICL7660 delivers an open-circuit output equal to the negative of the input voltage to within 0.1%. Capable of producing 20mA, the device has a power-conversion efficiency of about 98% for load currents of 2mA to 5mA. The use of two or more ICL7660s extends the device's capability, as will be shown later.

**Principles of Operation**

Since the ICL7660 multiplies either positive or negative voltages by a factor of two, it can be considered a simple voltage doubler. This basic voltage doubling operation is shown in Figure 1, where S<sub>1</sub> and S<sub>3</sub> are the switches used to charge C<sub>1</sub>, and S<sub>2</sub> and S<sub>4</sub> transfer the charge to C<sub>2</sub>. It differs from most voltage doublers in that the usual blocking diodes are replaced by on-chip active MOS transistor switches.

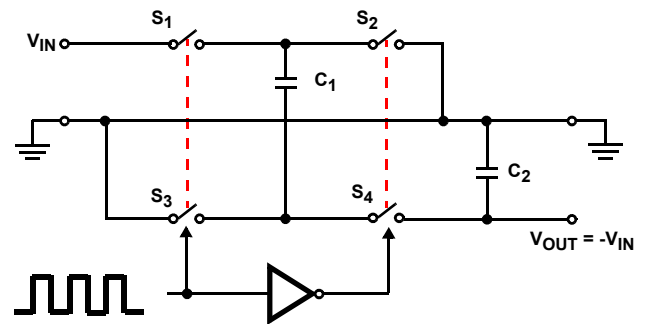

FIGURE 1. IDEALIZED VOLTAGE DOUBLER

For a negligible load, clearly the voltage inversion will be nearly perfect, with only a tiny charge being lost to stray capacitance. With a significant load, the behavior is more complex.

The amount of charge transferred from C<sub>1</sub> to C<sub>2</sub> depends upon the amount lost from C<sub>2</sub> to the load, and this charge must be made up by C<sub>1</sub> from the basic power supply. The switches themselves also have series resistance, leading to further theoretical complications, but the net result is a typical overall output impedance of around 55Ω (100Ω Max), provided that the capacitors are sufficiently large. For the natural oscillation frequency of the built-in oscillator (approximately 10kHz) values of 10μF are adequate.

The complete implementation of this function is achieved on a single CMOS chip, as shown in Figure 2.

The ICL7660 contains all the necessary conversion functions on-chip, except for the external pump and output reservoir capacitors and is made with a low-threshold CMOS technology using p- and N-Channel transistors that turn on at 0.6V. The low power dissipation, simplicity, and small chip size of CMOS make it a near-ideal technology for this application.

The ICL7660 contains an RC oscillator, a series voltage regulator, a voltage-level translator, and a logic network (Figure 2). The logic network senses the voltage on the sources and drains of the two output N-Channel transistors Q3 and Q4 and ensures that their substrates are always correctly biased.

**Power Efficiency**

In the case where a capacitor is charged and discharged between two voltages, V<sub>1</sub> and V<sub>2</sub>, the energy lost is defined by

$$E = \frac{C(V_1^2 - V_2^2)}{2}$$

where C is value of the capacitor in farads and E is the lost energy. If  $V_1 = V_2$  is very small compared with  $V_1$ , the percentage energy loss is also small, given as:

$$\frac{100(V_1^2 - V_2^2)}{2(V_1^2)}$$

At the limit, when  $V_2 = V_1$ , no energy is lost. If the values of  $C_1$  and  $C_2$  in Figure 1 are made very large and their impedances at the switching frequency are very low compared with the load resistance, energy-conversion efficiencies approaching 100%

can be obtained. Energy is lost only by a change of voltage during the transfer of charge into and out of a capacitor.

### Detailed Description

#### Oscillator - Divider - Regulator

The ICL7660S oscillator (Figure 3) drives a conventional divide-by-2 counter whose principal function is to supply a 50% duty cycle output (at half the input frequency) to the voltage-level translator circuit. The conventional static counter requires a two-phase clock, and supplies an output signal and its complement.

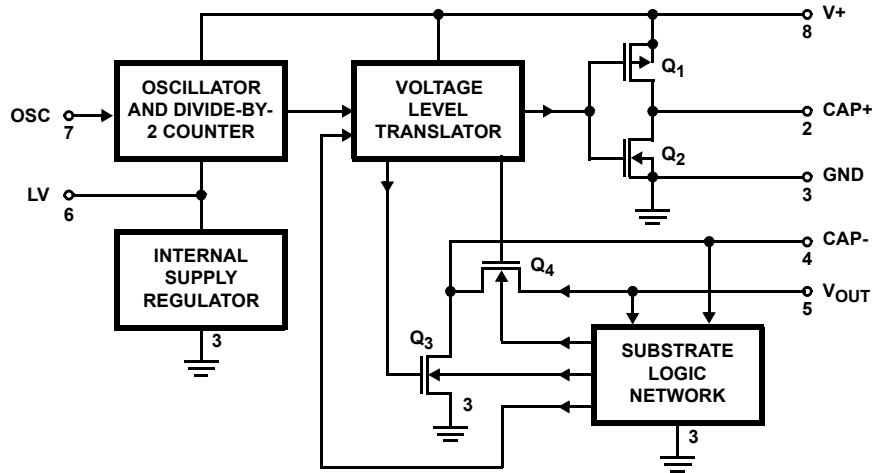

FIGURE 2. FUNCTIONAL DIAGRAM OF COMPLETE CHIP

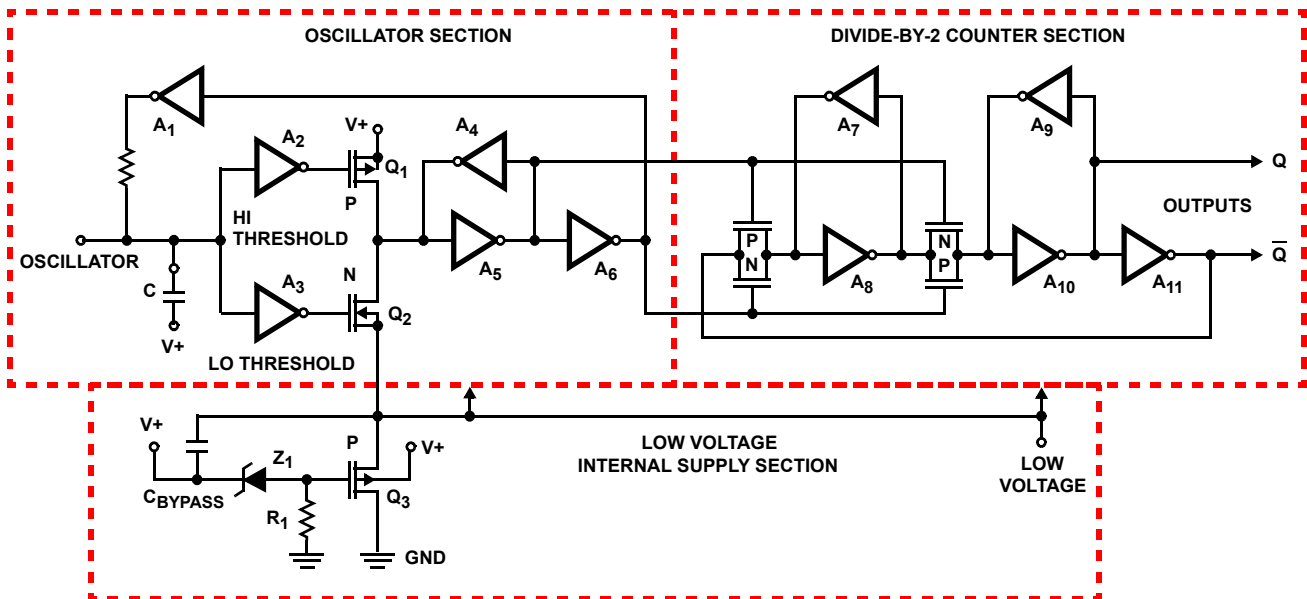

FIGURE 3. THE ICL7660S OSCILLATOR, DIVIDER AND INTERNAL REGULATOR

When the output of inverter A1 is switched high, capacitor C charges positively until inverter A2 (which has a high input-voltage trip point) switches its output low, to turn on transistor Q<sub>1</sub>. Q<sub>1</sub> in turn forces the ratioed-inverter latch A4 - A5 to switch its output low. C then discharges negatively until inverter A3 (which has a low input-voltage trip point) switches its output high, turning on transistor Q<sub>2</sub>. The output of Q<sub>2</sub> resets A<sub>4</sub> - A<sub>5</sub> and restarts the cycle.

Since the oscillator has a high input impedance of about 1MΩ, it may be driven from an external source such as a TTL gate or equivalent, or its frequency may be lowered by the addition of an external capacitor. At room temperature with a +5V supply and no external capacitor, the oscillator frequency will be 10kHz. The internal capacitance is about 10pF.

A series voltage regulator consisting of zener reference diode Z<sub>1</sub>, resistor R<sub>1</sub>, and source-follower P-Channel transistor Q<sub>3</sub> provides a partially regulated supply for all the low voltage circuitry on the chip. The regulator can supply up to -5V (with respect to the positive power supply) for input supply voltages

of about 6V and higher. Because of the modest size of Q<sub>3</sub>, the voltage regulator not only reduces power consumption at high supply voltages, but also limits the maximum current taken by the oscillator and the divide-by-2 counter.

The LV terminal can be used to short out the on-chip series regulator for better operation at low supply voltages. With the Low-Voltage terminal connected to ground, operation with an input supply voltage as low as 1V is possible. At higher voltages, however, it is mandatory that this terminal be open, in order to allow the internal voltage regulator to stop device latchup and avoid internal damage.

### The Level-Translator and Output Switches

The level translators (Figure 4) provide switching signals to the gates of the four output transistors, Q<sub>1</sub> through Q<sub>4</sub>, with amplitudes equal to the sum of the output and supply voltages. They also ensure that a break-before-make sequence takes place as switching alternates between charge and pump configurations.

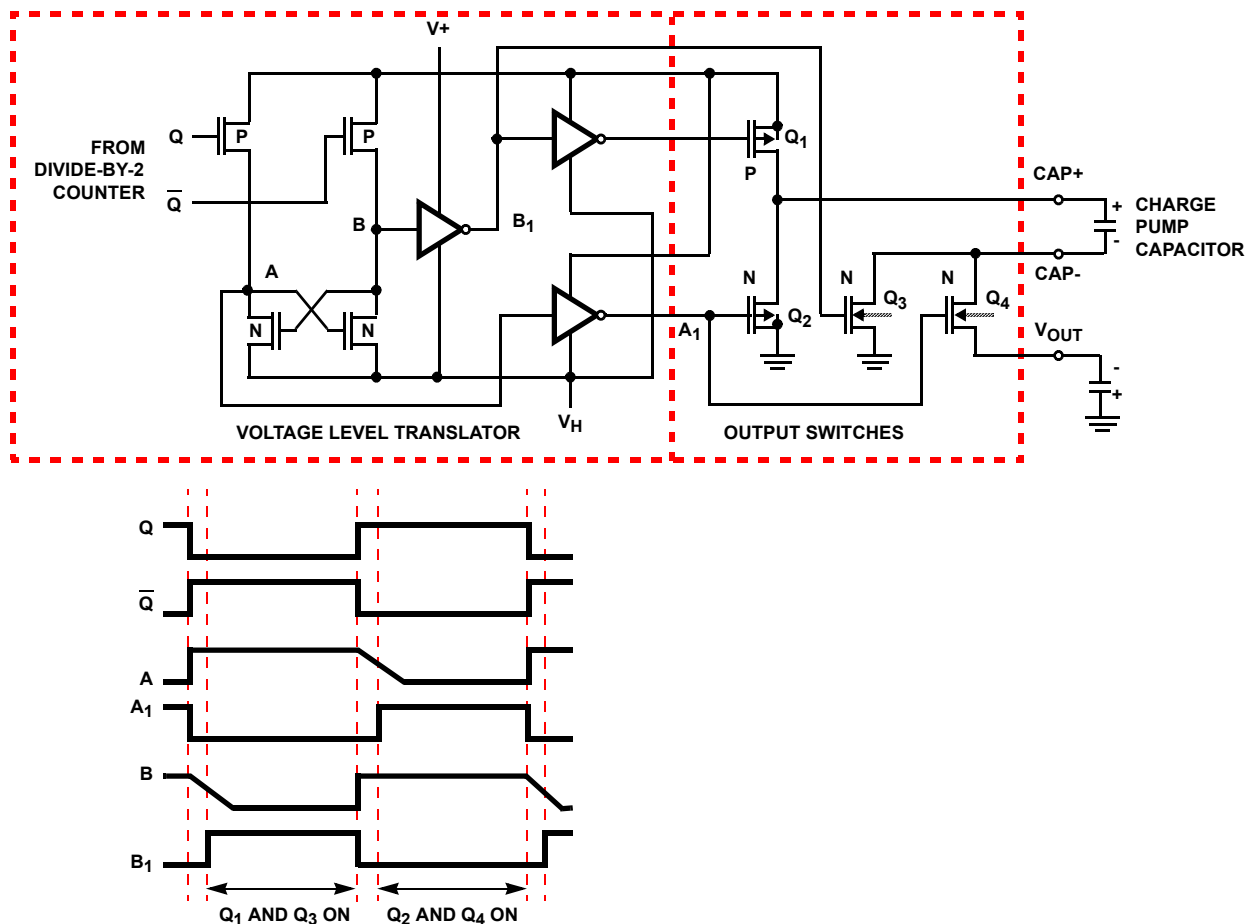

FIGURE 4. THE ICL7660S OUTPUT SWITCHES AND VOLTAGE LEVEL TRANSLATOR CIRCUIT

### The Substrate Logic Network

The substrate logic network (Figure 5) is the most critical part of the converter chip. Its two main functions are to make sure that the substrates of  $Q_2$  and  $Q_4$  (Figure 4) are never forward-biased with respect to their sources and drains, and to establish the most negative voltage of any part of the circuit in either the charge or the pump cycles. This internal negative supply,  $V_{-}$ , is used to power the level translators. It drives the gate of either  $Q_3$  or  $Q_4$  to a voltage similar to that of the sources to ensure transistor turn off.

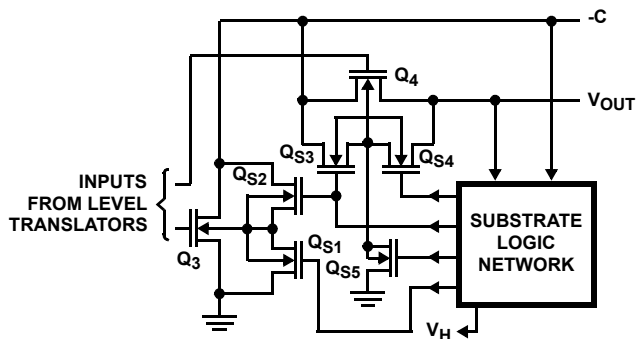

FIGURE 5. THE SUBSTRATE LOGIC NETWORK

Transistors  $Q_3$  and  $Q_4$  require special drive considerations, since the sources and drains are inverted on each device during pump and charge phases. Consider  $Q_3$ 's operation, for example. During the charge phase, the most positive source/drain terminal is connected to the external charge-pump capacitor. This terminal is then, by definition, the drain, whereas the source which is more negative is connected to ground. To minimize  $Q_3$ 's resistance, it is also desirable to connect its substrate to ground and not to the output voltage or to  $V_H$ , since reverse-biasing the substrate of an MOS transistor with respect to its source increases its threshold voltage, and therefore the ON resistance.

During the pumping phase, the external capacitor's negative terminal is shifted negatively by a voltage approximately equal to the supply voltage. In this case, the most negative source/drain terminal is connected to the negative side of the external capacitor (and thus becomes the source of  $Q_3$ ), and its drain is connected to ground.

Similar source-drain reversals occur for  $Q_4$  except that here conditions are different for output short-circuit operation than during normal operation. Sensing circuitry monitors the voltages on the external capacitors negative side and  $V_{OUT}$ , and compares them with ground. The substrate of  $Q_4$  is then connected to the most negative of them. Figure 5 shows the substrate steering transistors for  $Q_3$  and  $Q_4$ . The steering transistors ( $Q_{S1-5}$  are relatively small N-Channel devices, and share  $Q_3$  and  $Q_4$ 's substrates).

### SCR Latch Up

A CMOS device is inherently a four-layer, or silicon-controlled-rectifier (SCR), structure. This structure can be turned on

through the forward biasing of the inherent pn junctions, and unless external current-limiting circuitry is used, latchup and resultant failure can occur.

The N-Channel transistor source acts as the cathode of the SCR, and the p+ source of the P-Channel transistor acts as the anode. Either N- or P-Channel drains can act as the SCR gate. With about 2V or more across the anode and cathode, the SCR can have either a low-impedance (ON) or high impedance (OFF) state. For the ON state to occur, three things must happen: the product of the transistors' current gains, or betas, must be at least unity, a current greater than the holding current must be present, and a trigger pulse must be applied to either gate of the SCR. Trigger signals may be caused by static discharge on the gates or by connecting either gate to the power supplies before connecting Power-supply lines to other terminals of the SCR. Even extremely high rates of voltage change across any two or more SCR pn junctions can produce latchup.

Triggering a CMOS SCR causes it to present an extremely low impedance ( $1\Omega$  to  $100\Omega$ ) across the power supply. Unless the power supply is current-limited, the device latches up and is often destroyed, usually by the vaporization of one of the bonding wires.

Although ICL7660 output-section switching transients are mainly capacitive, they inject currents into the substrate. At high input supply voltages, these transients can forward-bias junctions associated with the p- well or the  $Q_4$  substrate. This in turn may trigger the inherent SCR in  $Q_4$  and the adjacent on-chip circuitry. The result is to rapidly discharge the reservoir capacitor.

After the reservoir capacitor is almost totally discharged and the current in the SCR has fallen below the holding value, the device again operates correctly, until the output voltage (reservoir capacitance voltage) reaches the same critical value, and the latchup phenomenon starts again. Since this effect occurs only during the start of the charge cycle, and not during the pump cycle, isolating the reservoir capacitor with an external diode at the  $V_{OUT}$  terminal prevents capacitor discharge. This is recommended when using the device at higher voltage and temperatures. Otherwise the substrate logic network prevents SCR triggering, which is therefore not a problem for most operating conditions.

### Basic Application

The applications of the ICL7660 are remarkably varied, especially considering the rather narrow nature of the basic device function.

The basic circuit is shown in Figure 6, and the output characteristics for 5V inversion in Figure 7. For light loads, the output voltage follows the input very precisely, while for heavier loads, the output can be viewed as having perfect inversion, plus an output resistance of about  $55\Omega$ .

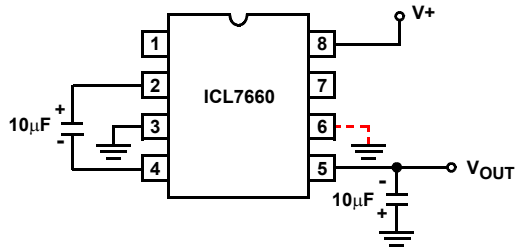

FIGURE 6. SIMPLE NEGATIVE CONVERTER

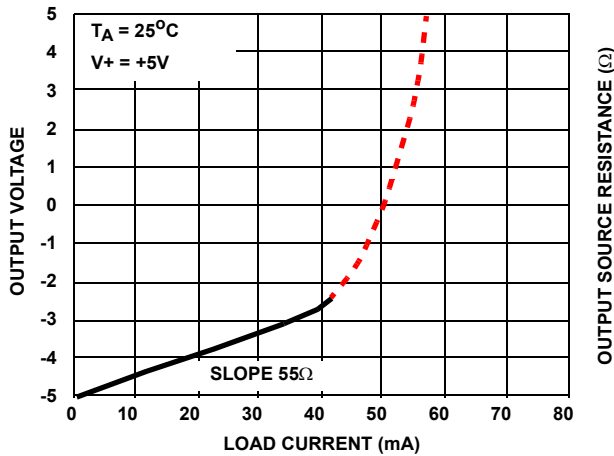

FIGURE 7. OUTPUT CHARACTERISTICS

Thus at 18mA load, the output voltage drops about 1V below the input. Beyond around 40mA, the voltage drop becomes very nonlinear, and the circuit self-limits, thereby protecting itself against excessive power dissipation. The output ripple is dependant primarily upon the output capacitor, since this must hold up the load during half the cycle time (or one oscillator period). In the steady-state case, this ripple is made up during the other half cycle time, and enough pump capacitance should be used to ensure that this is done monotonically. The recommended values ensure this for the internal oscillator frequency.

For operation at low voltages, the output impedance begins to rise rather rapidly, as a result of reduced turn-on voltage on the MOSFET switches (Figure 8). This effect can be reduced by bypassing the internal regulator, tying LV to Ground, as shown in Figure 9. This must not be done, however, if the incoming supply an exceed 8V under any circumstances, as the Internal logic oscillator and divider stages will be damaged. Note also the use of a series diode (Dx) at higher voltage and temperature, to protect the device against SCR action.

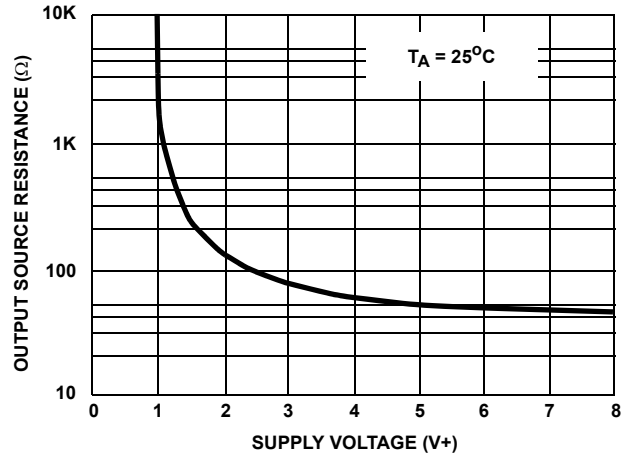

FIGURE 8. OUTPUT RESISTANCE

Figure 9 also shows an external oscillator capacitor. This can be used to reduce the oscillator frequency, giving a slight improvement in efficiency; see Figure 10.

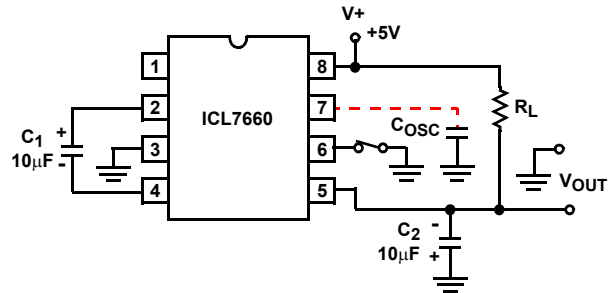

FIGURE 9. VARIATIONS OF BASIC CIRCUIT

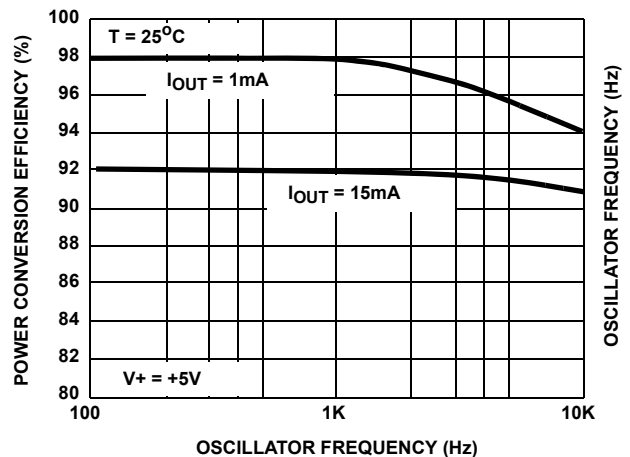

FIGURE 10. EFFICIENCY CHANGE WITH OSCILLATOR FREQUENCY

The dependence of the frequency on this external capacitance is shown in Figure 11. This can also be done to move the frequency away from a band of undue sensitivity to EMI in a system. However the output ripple will be increased, and the output impedance also unless the pump and storage capacitors are correspondingly increased.

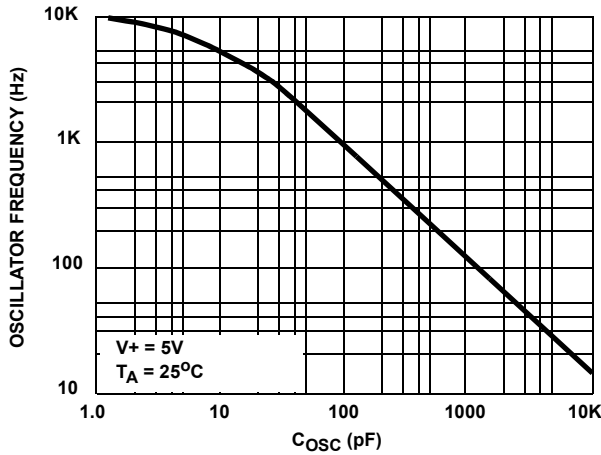

FIGURE 11. FREQUENCY VARIATION WITH OSCILLATOR CAPACITANCE

Synchronization to an external clock can be readily achieved, as shown in Figure 12. A TTL device can be used with the addition of a pull-up resistor ( $10k\Omega$  to  $V+$  is suitable), as can any input swinging rail-to-rail on the positive supply. The series resistor prevents problems with overdrive on the internal logic. Output transitions occur on the positive edge of the external input.

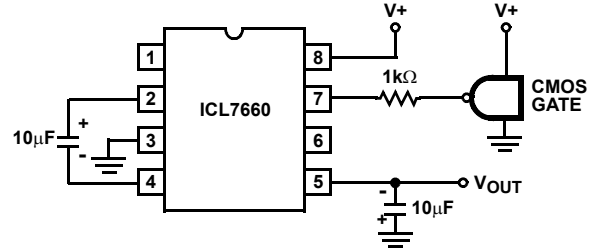

FIGURE 12. EXTERNAL CLOCKING

### Wider (Parallel Connections)

For applications where the voltage drop due to load current is excessive, several ICL7660s can be paralleled. Normally this cannot be done efficiently with power supply circuits, since each one has a different idea of where the "ideal" output voltage would be and they usually end up fighting each other. However, here they see equal input voltages, and the virtually perfect inversion assures that each one does have the same idea of where the output should be so load sharing is assured. Each device must have a separate pump capacitor, since the oscillators cannot be synchronized except with an external drive, and even then the -2 will be in a random condition. The connections are shown in Figure 13. Naturally the output capacitor is common to each device. Running independently, the ripple content will include components at the difference frequency as well as the individual pumping frequencies. If this is undesirable, a single exclusive NOR gate can be used to put two ICL7660s into antiphase by comparing the outputs on pin 2, and clocking one to maintain near synchronization with the basic oscillator of the other, as shown in Figure 14.

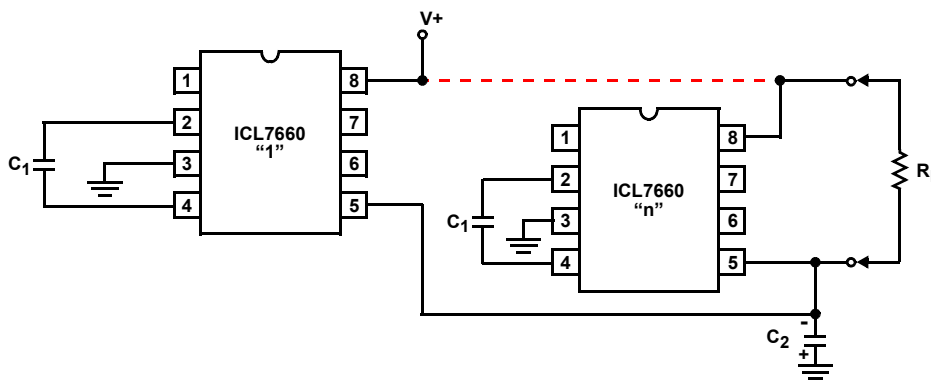

FIGURE 13. PARALLELING DEVICES

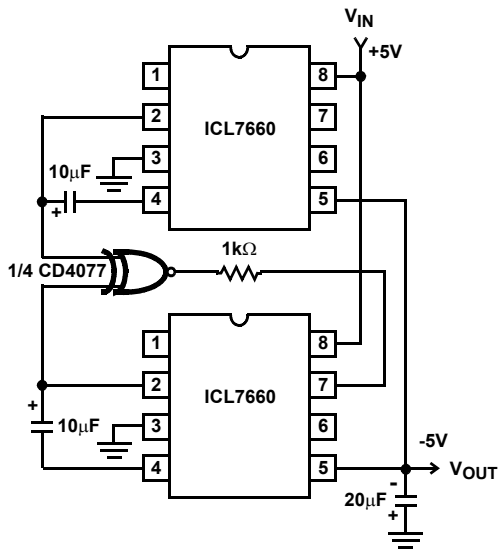

FIGURE 14. SYNCHRONIZING TWO ICL7660S

The concept can be extended to drive four devices in four separate phases, using a single extra logic-gate package, as shown in Figure 15. The duty cycle of the oscillator is reasonably close to 50%, so driving two pairs, each in the configuration of Figure 14, from opposite phases of the oscillator gives four separately-timed pumps per cycle. This circuit will give about 75mA output before the voltage drops by 1V, or an output impedance of under 14Ω. The four phase operation minimizes the ripple, while ensuring very even load sharing. For even more parallel synchronous device, a Johnson counter using Q and Q outputs should be considered.

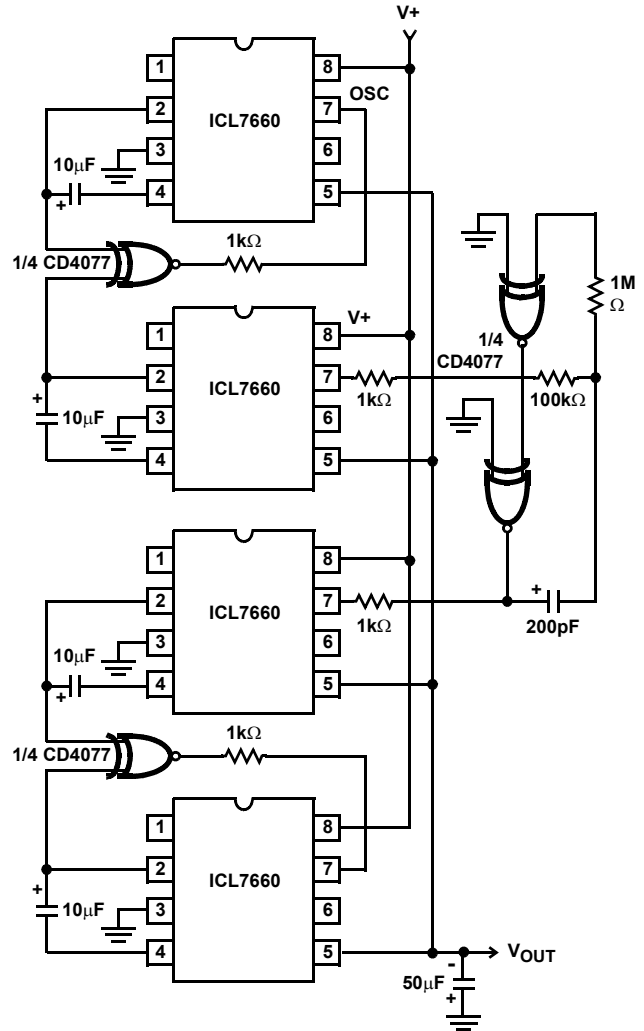

FIGURE 15. SYNCHRONIZING A QUAD

### Deeper (Series Connection)

It is also possible to connect ICL7660s in series, cascading them to generate higher negative voltages. The basic connections are shown in Figure 16.

This technique can be extended to several multiplication levels. However, the basic limitations of this technique must be recognized. In line with the Laws of Thermodynamics, the input current required for each stage is twice the load current on that stage, plus the quiescent current required to operate that stage.

Thus the load current is rapidly multiplied down the chain, as shown in Figure 17. Note also that the quiescent current increases the load current on each stage, though not as fast as the ultimate load itself.

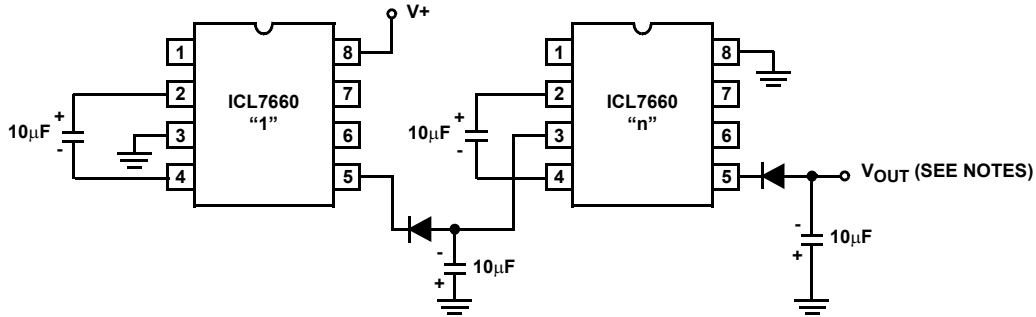

NOTES:

1.  $V_{OUT} = -n+$  for  $1.5V \leq V+ \leq 6.5V$
2.  $V_{OUT} = -n (V+ - V_{FOX})$  for  $6.5V \leq V+ \leq 10.0V$ .

FIGURE 16. CASCADING DEVICES FOR INCREASED OUTPUT VOLTAGE

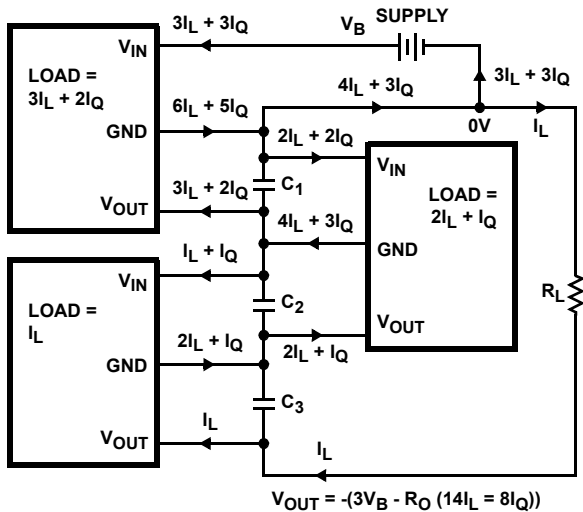

$V_{C1} = V_B - R_O (3I_L = 2I_Q)$   
 $V_{C2} = V_B - R_O (5I_L = 3I_Q)$   
 $V_{C3} = V_B - R_O (6I_L = 3I_Q)$

FIGURE 17. CURRENT FLOW FOR CASCADED DEVICES

Furthermore, the loss in voltage in early stages due to series resistance is multiplied through all subsequent stages. Thus the effective output impedance mounts rapidly with the number of stages. (See Table 1.) This effect can be reduced by paralleling devices in the lowest stages (see above.) If the weighting corresponds to the square of the position, the effective resistance to load current goes up only linearly with the number of stages, but the cost quickly becomes prohibitive. Nevertheless, for light loads and moderate multiplication, useful performance can be achieved.

TABLE 1.

# STAGES	RESISTANCE	MULTIPLIERS
n	$R_O(L)$	$R_O(Q)$
1	1	0
2	5	2
3	14	8
4	30	20
5	55	40

A variation of this circuit, another form of series circuit, is shown in Figure 18. This circuit can be used effectively to generate -15V from +5V in light load applications using only two devices. The output impedance corresponds roughly to  $n = 2$  in Table 1, much better than if the previous circuit were used with  $n = 3$ . In general, geometric increases, as in Figure 18, are better until the voltage limit is reached, at which time arithmetic cascading as in Figure 16 must be utilized.

**Upside Down (Positive Multiplication)**

The ICL7660 may be employed to achieve positive voltage multiplication using the circuit shown in Figure 19. In this application, the pump inverter switches of the ICL7660 are used to charge  $C_1$  to a voltage level of  $V+ - V_F$  (where  $V+$  is the supply voltage and  $V_F$  is the forward voltage drop of diode  $D_1$ ) On the transfer cycle, the voltage on  $C_1$  plus the supply voltage ( $V+$ ) is applied through diode  $D_2$  to capacitor  $C_2$ . The voltage thus created on  $C_2$  becomes  $(2V+) - (2V_F)$  or twice the supply voltage minus the combined forward voltage drops of diodes  $D_1$  and  $D_2$ .

The source impedance of the output ( $V_{OUT}$ ) will depend on the output current, but for  $V+ = 5V$  and an output current of 10mA it will be approximately  $60\Omega$ .



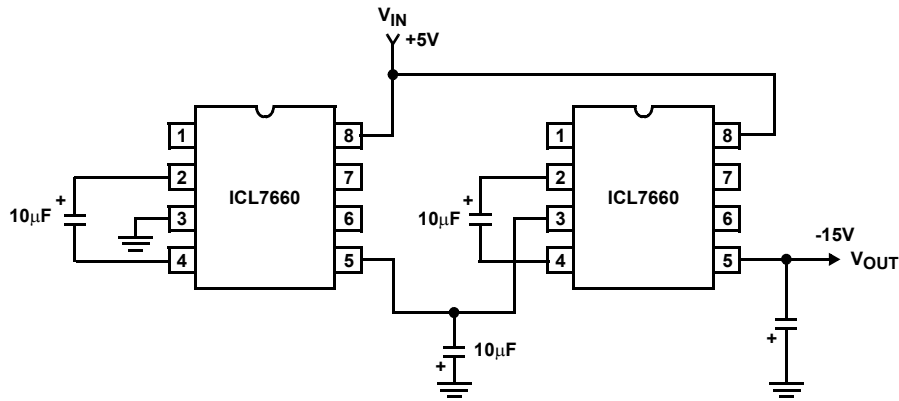

FIGURE 18. GETTING -15V FROM +5V

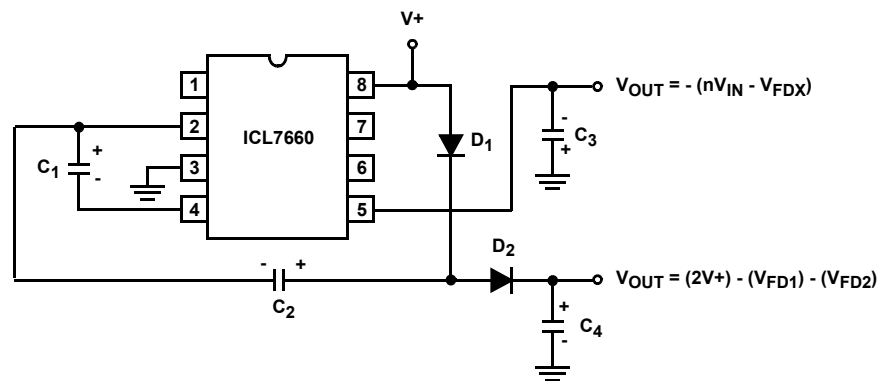

FIGURE 19. COMBINED NEGATIVE CONVERTER AND POSITIVE MULTIPLIER

### Divide and Conquer

The ICL7660 can be used to split a supply in half, as shown in Figure 20.

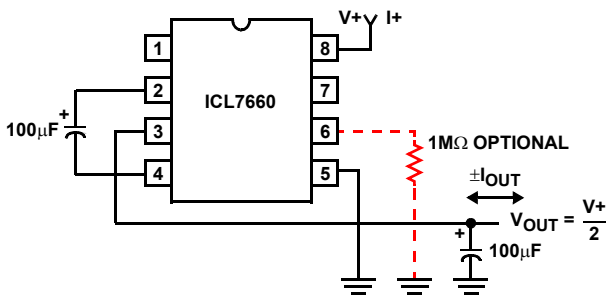

FIGURE 20. EFFICIENT SUPPLY SPLITTING

Here the “basic” output connection and the “basic” negative supply input are exchanged and the output voltage thus becomes the midpoint. Start-up can be a problem, and although careful capacitance and load balancing may frequently be adequate, a simple resistor to LV will always work. The circuit is useful for series-fed line systems, where a heavy local load at low voltage can be converted to a lighter current, at high voltage. Other useful applications are in driving low voltage (e.g., +7.5V) circuits from  $\pm 15V$  supplies, or low

voltage logic from 9V or 12V batteries. The output impedance is extremely low; all parts of the circuit cooperate in sharing the current, and so act in parallel.

For other division ratios, the series configurations of Figure 16 can be driven backwards, to generate  $V_{IN}/n$ , or even  $m/n(V_{IN})$ , for small values of  $m$  and  $n$ . Again, care must be taken to ensure start up for each device.

One interesting combination of several preceding circuits is shown in Figure 21, where a +15V supply is converted, via +7.5V and -7.5V, to -1.5V using three ICL7660s. The output impedance of this circuit is about 250 $\Omega$ .

For cases where the output impedance of an ICL7660 circuit is too high, obviously some form of output regulation can be used. However in most cases adequate regulation can be achieved at high efficiency by pre-regulating the input. A suitable circuit is shown in Figure 22, using the ICL7611 low power CMOS op amp. Because of the large source-current capability of this op amp, even on its lowest bias current setting, very efficient operation is possible. An ICL8069 bandgap device is used as the reference generator for the regulator. The output impedance can be reduced to 4 $\Omega$ , while maintaining a current capability of well over 10mA. In designing circuits of this type, it is important to remember that there is a switching delay averaging one oscillator cycle between the

output of the op amp and the actual output voltage. This can have substantial repercussions on the transient response if the time-constants in the circuit are not adequate. If multiple voltage converters are used, synchronization schemes such as those of Figures 14 and 15 are probably advisable.

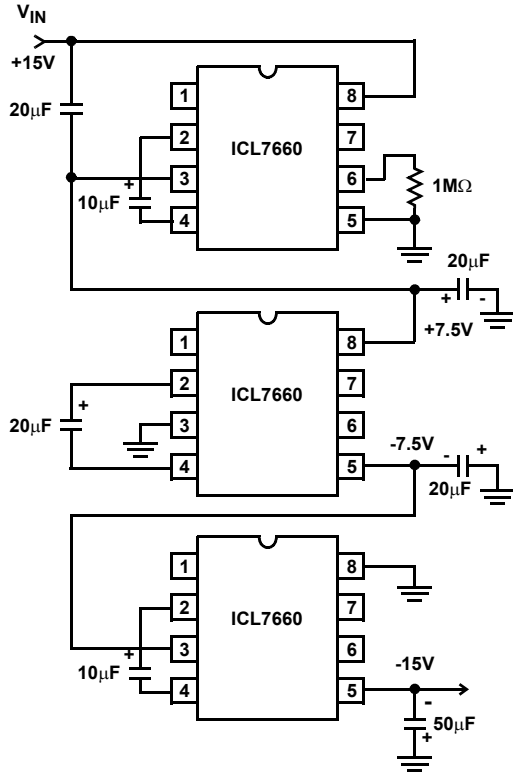

FIGURE 21. +15V TO -15V IN THREE EASY STAGES

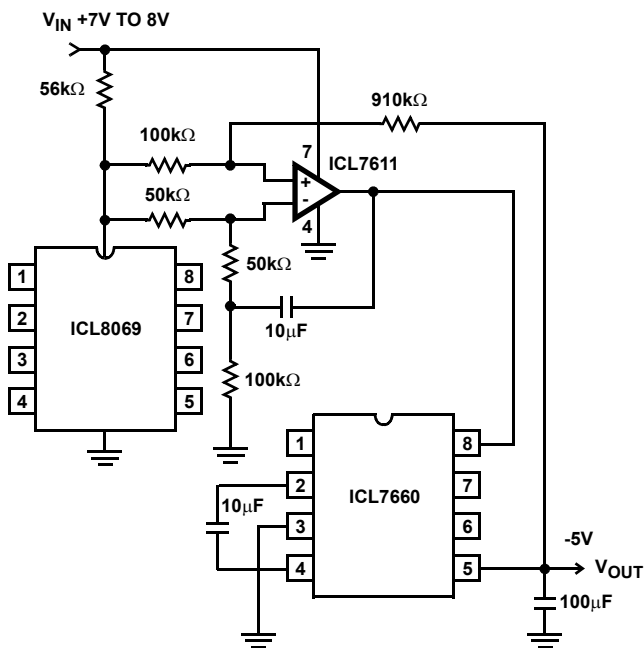

FIGURE 22. REGULATED OUTPUT INVERTER

### Messing About

The applications shown so far have corresponded to the use of the ICL7660 as a sort of equivalent of single turns on a power transformer, with paralleled turns to get more current, series turns for more voltage, etc. However, there are some other possibilities. By looking again at the block diagram (Figure 2), it is evident that the device could be used as a 50% duty cycle high power clock driver, using either the internal oscillator or an external signal, as in Figure 23. An antiphase clock can also be derived from the circuit, as shown, but the pull-up on this output, being an N-Channel switch only, does not have as good a voltage swing. It is adequate for TIC level operation, but for CMOS clocking may require an external pull-up resistor or transistor.

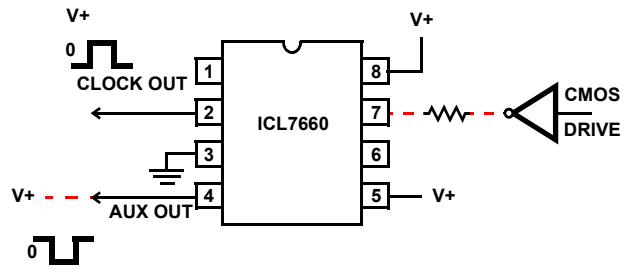

FIGURE 23. HIGH POWER CLOCK DRIVE

Another interesting class of applications comes from the capability to synchronously detect the output of an AC driven transducer, as shown in Figure 24. (This could be viewed as a signal transformer application.) Although the circuit shown utilizes a linear transformer type of transducer, any similar device may be used. The output voltage, which is correctly phased and of either polarity, may be fed into an A/D converter for display or microprocessor interface as desired.

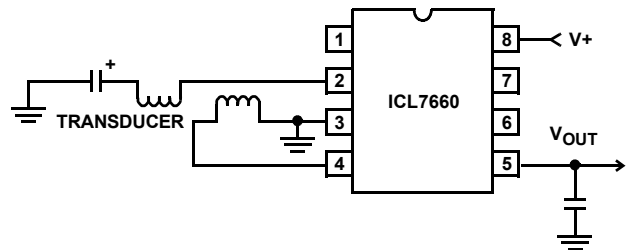

FIGURE 24. TRANSDUCER DRIVER AND DETECTOR

## Notice

1. Descriptions of circuits, software and other related information in this document are provided only to illustrate the operation of semiconductor products and application examples. You are fully responsible for the incorporation or any other use of the circuits, software, and information in the design of your product or system. Renesas Electronics disclaims any and all liability for any losses and damages incurred by you or third parties arising from the use of these circuits, software, or information.
2. Renesas Electronics hereby expressly disclaims any warranties against and liability for infringement or any other claims involving patents, copyrights, or other intellectual property rights of third parties, by or arising from the use of Renesas Electronics products or technical information described in this document, including but not limited to, the product data, drawings, charts, programs, algorithms, and application examples.
3. No license, express, implied or otherwise, is granted hereby under any patents, copyrights or other intellectual property rights of Renesas Electronics or others.
4. You shall not alter, modify, copy, or reverse engineer any Renesas Electronics product, whether in whole or in part. Renesas Electronics disclaims any and all liability for any losses or damages incurred by you or third parties arising from such alteration, modification, copying or reverse engineering.
5. Renesas Electronics products are classified according to the following two quality grades: "Standard" and "High Quality". The intended applications for each Renesas Electronics product depends on the product's quality grade, as indicated below.  
"Standard": Computers; office equipment; communications equipment; test and measurement equipment; audio and visual equipment; home electronic appliances; machine tools; personal electronic equipment; industrial robots; etc.  
"High Quality": Transportation equipment (automobiles, trains, ships, etc.); traffic control (traffic lights); large-scale communication equipment; key financial terminal systems; safety control equipment; etc.  
Unless expressly designated as a high reliability product or a product for harsh environments in a Renesas Electronics data sheet or other Renesas Electronics document, Renesas Electronics products are not intended or authorized for use in products or systems that may pose a direct threat to human life or bodily injury (artificial life support devices or systems; surgical implantations; etc.), or may cause serious property damage (space system; undersea repeaters; nuclear power control systems; aircraft control systems; key plant systems; military equipment; etc.). Renesas Electronics disclaims any and all liability for any damages or losses incurred by you or any third parties arising from the use of any Renesas Electronics product that is inconsistent with any Renesas Electronics data sheet, user's manual or other Renesas Electronics document.
6. When using Renesas Electronics products, refer to the latest product information (data sheets, user's manuals, application notes, "General Notes for Handling and Using Semiconductor Devices" in the reliability handbook, etc.), and ensure that usage conditions are within the ranges specified by Renesas Electronics with respect to maximum ratings, operating power supply voltage range, heat dissipation characteristics, installation, etc. Renesas Electronics disclaims any and all liability for any malfunctions, failure or accident arising out of the use of Renesas Electronics products outside of such specified ranges.
7. Although Renesas Electronics endeavors to improve the quality and reliability of Renesas Electronics products, semiconductor products have specific characteristics, such as the occurrence of failure at a certain rate and malfunctions under certain use conditions. Unless designated as a high reliability product or a product for harsh environments in a Renesas Electronics data sheet or other Renesas Electronics document, Renesas Electronics products are not subject to radiation resistance design. You are responsible for implementing safety measures to guard against the possibility of bodily injury, injury or damage caused by fire, and/or danger to the public in the event of a failure or malfunction of Renesas Electronics products, such as safety design for hardware and software, including but not limited to redundancy, fire control and malfunction prevention, appropriate treatment for aging degradation or any other appropriate measures. Because the evaluation of microcomputer software alone is very difficult and impractical, you are responsible for evaluating the safety of the final products or systems manufactured by you.
8. Please contact a Renesas Electronics sales office for details as to environmental matters such as the environmental compatibility of each Renesas Electronics product. You are responsible for carefully and sufficiently investigating applicable laws and regulations that regulate the inclusion or use of controlled substances, including without limitation, the EU RoHS Directive, and using Renesas Electronics products in compliance with all these applicable laws and regulations. Renesas Electronics disclaims any and all liability for damages or losses occurring as a result of your noncompliance with applicable laws and regulations.
9. Renesas Electronics products and technologies shall not be used for or incorporated into any products or systems whose manufacture, use, or sale is prohibited under any applicable domestic or foreign laws or regulations. You shall comply with any applicable export control laws and regulations promulgated and administered by the governments of any countries asserting jurisdiction over the parties or transactions.
10. It is the responsibility of the buyer or distributor of Renesas Electronics products, or any other party who distributes, disposes of, or otherwise sells or transfers the product to a third party, to notify such third party in advance of the contents and conditions set forth in this document.
11. This document shall not be reprinted, reproduced or duplicated in any form, in whole or in part, without prior written consent of Renesas Electronics.
12. Please contact a Renesas Electronics sales office if you have any questions regarding the information contained in this document or Renesas Electronics products.  
(Note 1) "Renesas Electronics" as used in this document means Renesas Electronics Corporation and also includes its directly or indirectly controlled subsidiaries.  
(Note 2) "Renesas Electronics product(s)" means any product developed or manufactured by or for Renesas Electronics.

(Rev.4.0-1 November 2017)



### SALES OFFICES

Renesas Electronics Corporation

<http://www.renesas.com>

Refer to "<http://www.renesas.com/>" for the latest and detailed information.

**Renesas Electronics America Inc.**  
1001 Murphy Ranch Road, Milpitas, CA 95035, U.S.A.  
Tel: +1-408-432-8888, Fax: +1-408-434-5351

**Renesas Electronics Canada Limited**  
9251 Yonge Street, Suite 8309 Richmond Hill, Ontario Canada L4C 9T3  
Tel: +1-905-237-2004

**Renesas Electronics Europe Limited**  
Dukes Meadow, Millboard Road, Bourne End, Buckinghamshire, SL8 5FH, U.K.  
Tel: +44-1628-651-700, Fax: +44-1628-651-804

**Renesas Electronics Europe GmbH**  
Arcadiastrasse 10, 40472 Düsseldorf, Germany  
Tel: +49-211-6503-0, Fax: +49-211-6503-1327

**Renesas Electronics (China) Co., Ltd.**  
Room 1709 Quantum Plaza, No.27 ZhichunLu, Haidian District, Beijing, 100191 P. R. China  
Tel: +86-10-8235-1155, Fax: +86-10-8235-7679

**Renesas Electronics (Shanghai) Co., Ltd.**  
Unit 301, Tower A, Central Towers, 555 Langao Road, Putuo District, Shanghai, 200333 P. R. China  
Tel: +86-21-2226-0888, Fax: +86-21-2226-0999

**Renesas Electronics Hong Kong Limited**  
Unit 1601-1611, 16/F., Tower 2, Grand Century Place, 193 Prince Edward Road West, Mongkok, Kowloon, Hong Kong  
Tel: +852-2265-6688, Fax: +852-2886-9022

**Renesas Electronics Taiwan Co., Ltd.**  
13F, No. 363, Fu Shing North Road, Taipei 10543, Taiwan  
Tel: +886-2-8175-9600, Fax: +886-2-8175-9670

**Renesas Electronics Singapore Pte. Ltd.**  
80 Bendemeer Road, Unit #06-02 Hyflux Innovation Centre, Singapore 339949  
Tel: +65-6213-0200, Fax: +65-6213-0300

**Renesas Electronics Malaysia Sdn.Bhd.**  
Unit 1207, Block B, Menara Amcorp, Amcorp Trade Centre, No. 18, Jln Persiaran Barat, 46050 Petaling Jaya, Selangor Darul Ehsan, Malaysia  
Tel: +60-3-7955-9390, Fax: +60-3-7955-9510

**Renesas Electronics India Pvt. Ltd.**  
No.777C, 100 Feet Road, HAL 2nd Stage, Indiranagar, Bangalore 560 038, India  
Tel: +91-80-67208700, Fax: +91-80-67208777

**Renesas Electronics Korea Co., Ltd.**  
17F, KAMCO Yangjae Tower, 262, Gangnam-daero, Gangnam-gu, Seoul, 06265 Korea  
Tel: +82-2-558-3737, Fax: +82-2-558-5338