

**Introduction**

The InfiniBand architecture represents a significant evolution of high-performance, switched-fabric interconnect systems. The goal is to provide a high-performance, reliable, and scalable way to connect high-end servers to each other and to I/O subsystems, routers and switches that connect to the world outside the data center.

Available from Intersil is the ISL6160, an evolution of IC power sequencing, control and protection for InfiniBand I/O modules (IM). The ISL6160 is designed to address the unique power requirements of the InfiniBand (IB) industry initiative providing independent power control of both the VB (bulk) (+12V) and the VA (auxiliary) (+5V) power rails for a single port. This device can be implemented in both IB Class I (non isolated) and Class II (isolated) Power Topology applications.

Intersil also provides the ISL6160EVAL2 concept evaluation platform. The ISL6160EVAL2 is a complete InfiniBand Class I (non isolated) power topology evaluation platform which highlights the operation of the ISL6160 and the HIP6006 single output PWM controller. See Figure 1 for a simplified block diagram of the ISL6160EVAL2 platform. This evaluation platform allows the InfiniBand Module (IM) power supply designer to evaluate the concept of this design and apply this concept to a specific IM power requirement. The evaluation platform is configured for 5V Vout and 3.5A max lout capability where it exhibits an efficiency of 85%, all in a small 1.6 sq" area. See Figure 11 for a complete ISL6160EVAL2 schematic.

**Using the ISL6160EVAL2 Concept Board**

The ISL6160EVAL2 consists of a bus and load boards, representing the IB chassis and IM respectively. The bus board has terminals for VA and VB supplies. The load board with its staggered length connector fingers to emulate the IM connector then hot plugs into the socket as shown in Figure 2.

When the load board is inserted into the bus board, the stagger on the connector fingers, first provides VX\_RET, then VX connections, and finally the shortest finger emulates the VBx\_En\_L line connection.

Once VB\_In is connected the VB control portion of the circuit is biased but the VB Secondary Rail (TP1) is held off until the ISL6160 VB\_ON pin is signaled high. Local power enable signaling is provided through the LCL\_PWR\_EN jumper either as a hard tie 'high' with the jumper installed or through an external input signal, on TP6 with the jumper removed. A single logic gate IC, provides for the XORing of the VBxEN\_L and local power enable signals into the ISL6160 VB\_ON pin. At the time VB\_ON is asserted high the ISL6160 turns on the VB Secondary Rail in a soft start mode protecting the primary supply rail from sudden in-rush current. During turn-on, the

external gate capacitor of the N-Channel MOSFET, Q3 (VB switch) is charged with a 20µA current source resulting in a programmable ramp (soft start turn-on). An internal charge pump supplies the gate drive for the 12V VB supply switch driving the MOSFET gate to VB +5V. Once the VB Secondary Rail ramps to 10V the DC-DC\_En pin is pulled high thus enabling the accompanying voltage converter. The DC-DC converter then provides a well regulated output voltage to the load. For lab evaluation either an electronic or a passive load is suitable for supplying a load current.

The ISL6160 VA undervoltage lockout feature prevents turn-on of VA until VA\_In > 2.5V. It then enables the VA soft start and power up. The VA rising voltage output is a current limited ramp so that both the inrush current and voltage slew rate are limited, independent of load. This reduces supply droop due to surge and eliminates the need for additional external EMI filters. During operation, once a VA OC condition is detected the output current is limited to 1A for 12ms to allow transient conditions to pass. If VA is still in current limit after the current limit period has elapsed, the output is then latched off. The VA to the IM circuitry is latched off until reset by the disconnection and reconnection of the IM from the chassis backplane.

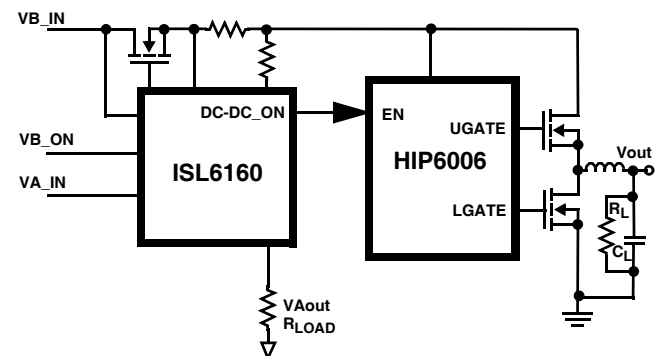

**FIGURE 1. ISL6160EVAL2 BLOCK DIAGRAM**

The VB Secondary Rail is enabled once the VB\_ON (TP7) is signalled high (through the assertion of the local power enable), then the DC-DC En pin (TP2) is pulled high to VB. The RC network of R4, R15 and C14 allows for setting the DC-DC converter enabling signal level and ramp, thus customizing the time to DC-DC enabling. Once the DC-DC is enabled the output (TP3) ramps to 5V. The output is supplied with a banana jack for connecting to an external active or passive load.

Figure 3 illustrates typical operational waveforms of the ISL6160EVAL2. These are accessible through the labeled test points (TPX) on the eval board.

See Figures 4 and 5 for ISL6160EVAL2 turn-on and turn-off output voltage waveforms.

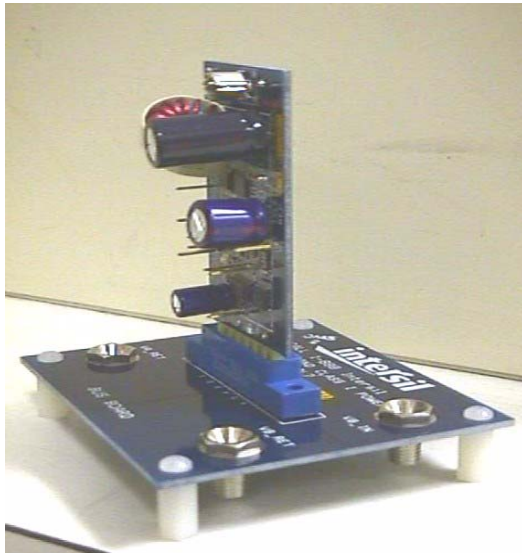

FIGURE 2. ISL6160EVAL2 PHOTOGRAPH

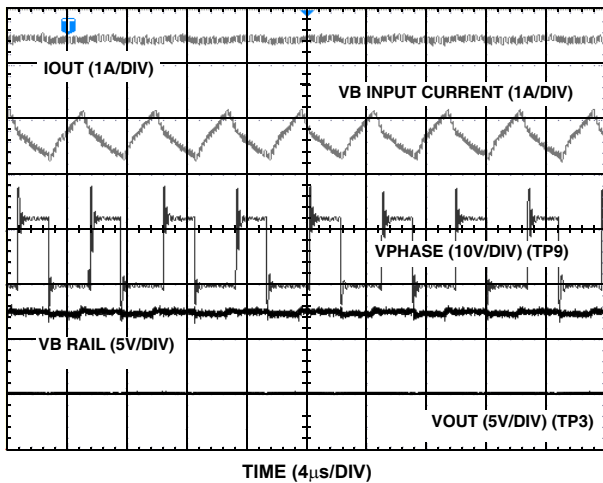

FIGURE 3. ISL6160EVAL2 OPERATIONAL WAVEFORMS

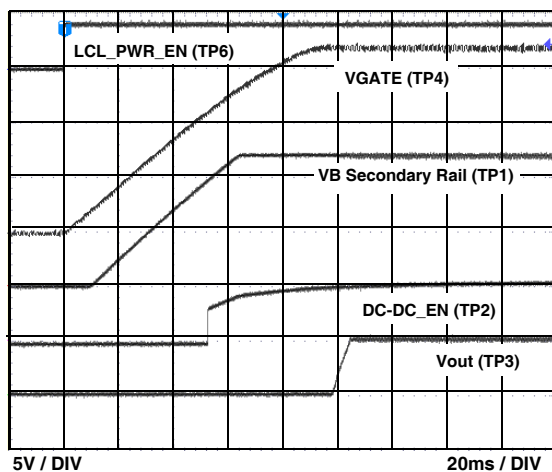

FIGURE 4. ISL6160EVAL2 Vout TURN-ON

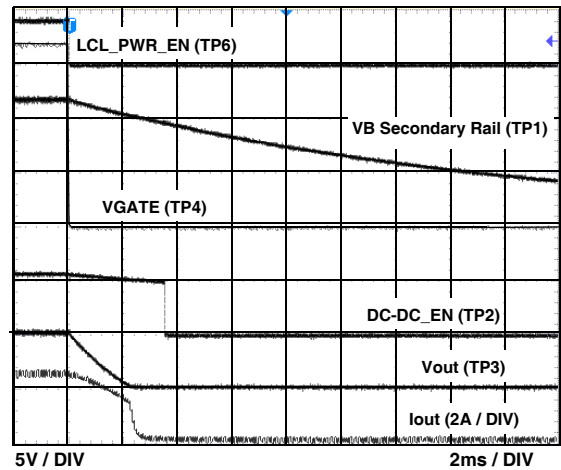

FIGURE 5. ISL6160EVAL2 Vout TURN-OFF

## ISL6160EVAL2 Performance

### Efficiency

Figure 6 displays the ISL6160EVAL2 efficiency versus load current. It highlights the efficiency advantages of a switching regulator at a higher load current. The designed current limit of this evaluation board is ~3.5A. The dashed portion of the curve was collected from a modified evaluation board with an increased overcurrent protection limit. The curve indicates maximum efficiency at about 4.5A of output current and approximately 25W of input power.

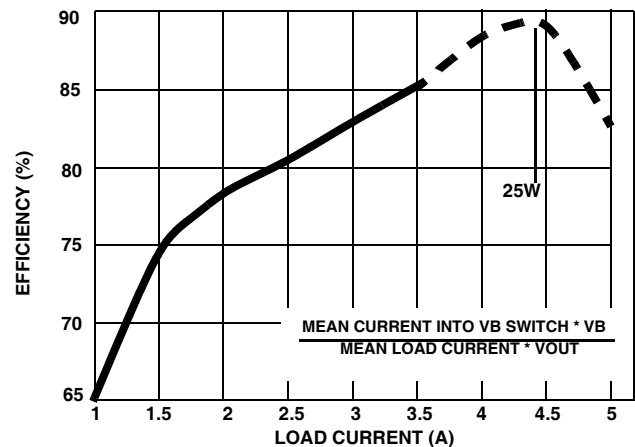

FIGURE 6. ISL6160EVAL2 EFFICIENCY vs LOAD CURRENT

ISL6160 related efficiency improvements can only come from lowering the  $R_{DSon}$  of the VB FET (Q3) switch and the threshold voltage across the sense resistor that invokes current regulation and shutdown. HIP6006 related efficiency improvements are explained in the Power Supply Design Considerations section of this document.

### Transient Response

Figure 7 shows a laboratory oscillogram of the ISL6160EVAL2 in response to a 0-3.5A, 250A/ms load transient. The output voltage responds rapidly and is within 2% of its nominal value in less than 150µs.

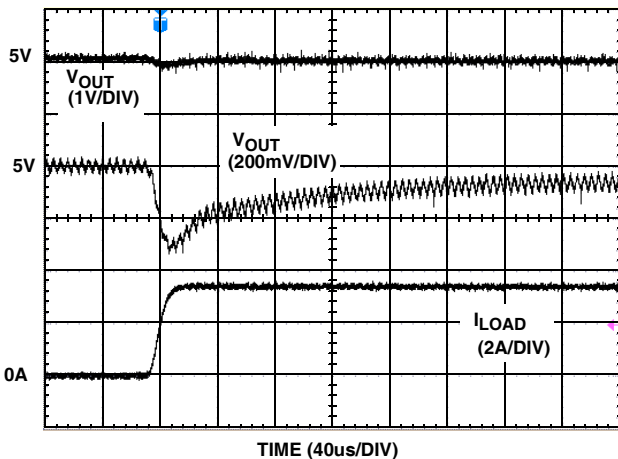

FIGURE 7. ISL6160EVAL2 TRANSIENT RESPONSE

### Output Current and Voltage Ripple

The output current and voltage ripple of the HIP6160EVAL2 is shown in Figure 8. The load current is 3.5A for this oscillogram. Peak-to-peak voltage ripple is about 60mV under these conditions.

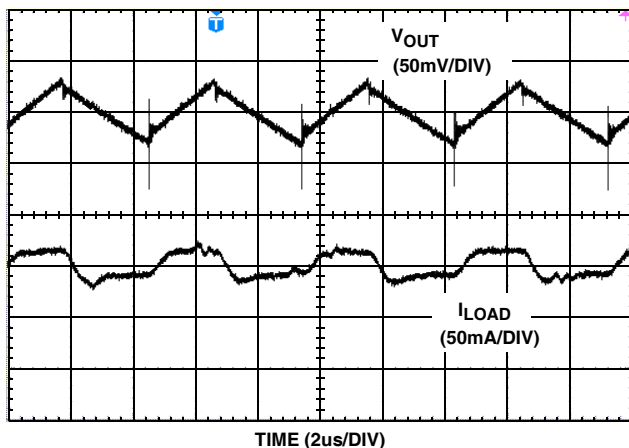

FIGURE 8. ISL6160EVAL2 OUTPUT RIPPLE

### OC Protection

With the ISL6160EVAL2 Class I power supply concept there are two areas of OC protection. The ISL6160 limits the current into the port, whereas the HIP6006 will limit current to the load.

#### ISL6160 OC Protection

The ISL6160EVAL2 is designed to input current limit to 2.8A, the max. specified peak current for a 25W port. This allows a maximum output current of ~3.5A at 5V output voltage. As I<sub>out</sub> increases above 3.5A the input current ripple peaks increase and are limited to 2.8A, beyond this point the ISL6160 reduces Q3 gate drive for current regulation (CR), causing a decrease in overall efficiency but protecting the VB primary rail. A lower limit based on the particular IM needs can be implemented to 'tighten' power budget control. This lower limit is based on the achieved efficiency of the down stream converter design and

the max. power capability of that converter output. At point of failure, by providing a lower current regulation limit on the I/O module the risk of passing through any rail voltage disruptions is reduced or eliminated by not having to rely on the overhead capacity of the chassis supply.

#### HIP6006 OC Protection

The HIP6006 has a loss less overcurrent (OC) protection feature. This is accomplished via the current-sense function of the HIP600x family. The HIP6006 senses converter load current by monitoring the drop across the upper MOSFET (Q2a in the Figure 11 schematic) enhancing the converter's efficiency and reducing cost by eliminating a current sensing resistor.

The over-current function cycles the soft-start function in a hiccup mode to provide fault protection. A resistor (R<sub>OCSET</sub>, R6) programs the over-current trip level. An internal 200μA (typical) current sink develops a voltage across R<sub>OCSET</sub> that is referenced to the VB secondary rail. When the voltage across the upper MOSFET (also referenced to VB secondary rail) exceeds the voltage across R<sub>OCSET</sub>, the over-current function initiates a soft-start sequence. The soft-start function discharges C<sub>SS</sub> with a 10μA current sink and inhibits PWM operation. The soft-start function recharges C<sub>SS</sub>, and PWM operation resumes with the error amplifier clamped to the SS voltage. Should an overload occur while recharging C<sub>SS</sub>, the soft start function inhibits PWM operation while fully charging C<sub>SS</sub> to 4V to complete its cycle. The converter dissipates very little power with this method.

The over-current function will trip at a peak inductor current (I<sub>PEAK</sub>) determined by:

$$I_{PEAK} = \frac{I_{OCSET} \cdot R_{OCSET}}{r_{DS(ON)}}$$

where I<sub>OCSET</sub> is the internal OCSET current source (200μA - typical). The OC trip point varies mainly due to the MOSFETs r<sub>DS(ON)</sub> variations. To avoid over-current tripping in the normal operating load range, find the R<sub>OCSET</sub> resistor from the equation above with:

1. The maximum r<sub>DS(ON)</sub> at the highest junction temperature.
2. The minimum I<sub>OCSET</sub> from the specification table.
3. Determine I<sub>PEAK</sub> for I<sub>PEAK</sub> > I<sub>OUT(MAX)</sub> + (ΔI)/2, where ΔI is the output inductor ripple current.

A small ceramic capacitor should be placed in parallel with R<sub>OCSET</sub> to smooth the voltage across R<sub>OCSET</sub> in the presence of switching noise on the input voltage.

Figure 9 illustrates the ISL6160EVAL2 OC operational waveforms. The 5V DC-DC output is shorted and the HIP6006 current limits it to 5A. When the Secondary Rail voltage decreases to 10V(TP1) the ISL6160 deasserts the DC-DC\_EN

pin (TP2) and shuts off the converter. The 1.6ms delay prevent spurious events from latching off the power supply.

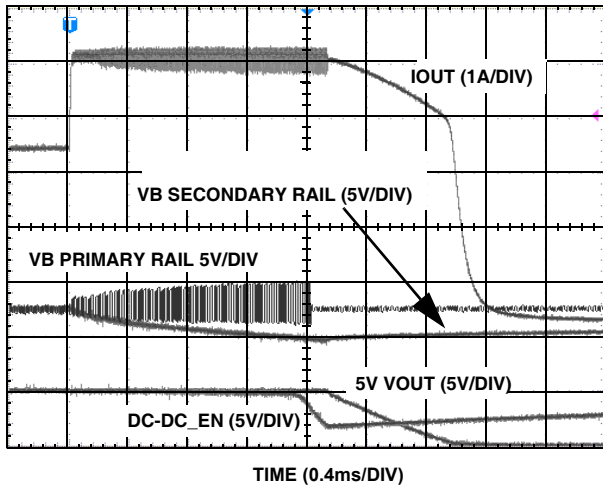

FIGURE 9. ISL6160EVAL2 OVER-CURRENT OPERATION

### Power Supply Design Considerations

The concept of the power supply demonstrated by the ISL6160EVAL2 can be scaled across the entire range of 1.3V to 12V of output voltage up to a 50W port power level. To encompass this entire range there are several component variables and trade-offs to consider. These variables and trade-offs are briefly discussed in this document, but for a more detailed and extensive explanation please refer to the several listed documents [2], [4], [5] on page 5.

### Input Capacitor Selection

Use a mix of HIP6006 input (VB secondary rail) bypass capacitors to control the voltage overshoot across the MOSFETs. Use small ceramic capacitors for high frequency decoupling and bulk capacitors to supply the current needed each time Q1 turns on. The number of input capacitors and their capacitance are usually determined by their maximum RMS current rating. A conservative approach is to determine the converter maximum input RMS current, and assume it would all have to be supplied from the input capacitors. By providing enough capacitors to meet the required RMS current rating, one usually provides enough capacitance for proper power de-coupling.

### MOSFET Selection Effect on Efficiency [4]

This section shows graphically that a larger, lower RDS(on) MOSFET does not always improve converter efficiency. Figure 10 shows that smaller RFP25N05 MOSFETs are more efficient over most of the line and load range than larger RFP45N06 MOSFETs. The RFP25N05 has a  $r_{DS(ON)}$  of 47mΩ (maximum at 25°C) versus 28mΩ for the RFP45N06. In comparison to the RFP25N05, the RFP45N06's gain in switching losses offsets its decreased conduction losses at load currents up to about 9A. This data reinforces the need to consider both switching

and conduction losses of the MOSFETs. This data is taken from the HIP6006EVAL1 platform.

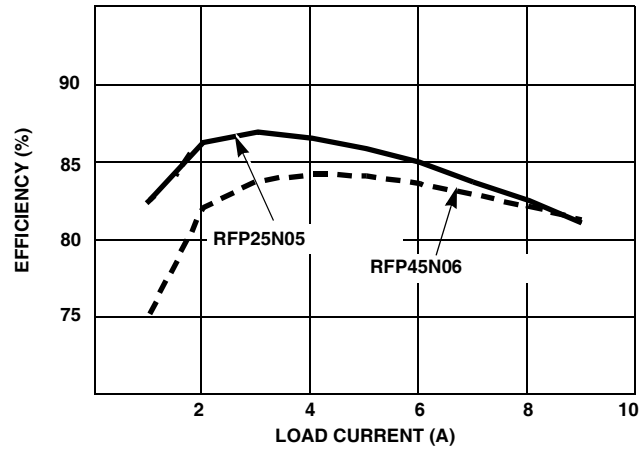

FIGURE 10. HIP6006EVAL1 EFFICIENCY WITH EITHER RFP25N05 OR RFP45N06 MOSFETs

### Setting the Output Voltage

Simple resistor value changes allow for outputs as low as 1.3V or as high as the 12V input voltage. The steady-state DC output voltage can be set using the following simple formula:

$$V_{OUT} = V_{REF} \cdot \left(1 + \frac{R8}{R5}\right), \text{ where}$$

$V_{OUT}$  = desired DC output voltage of the converter

$V_{REF}$  = HIP6006 internal reference voltage (typically 1.27V)

### Output Capacitor Selection

Output capacitors are required to filter the output and supply the load transient current. The filtering requirements are a function of the switching frequency and the ripple current. The load transient requirements are a function of the slew rate (di/dt) and the magnitude of the transient load current. These requirements are generally met with a mix of capacitors and careful layout. As with the input capacitors, the number of output capacitors is determined by a parameter different than sheer capacitance. Based on the desired output ripple and output transient response, a maximum ESR can be determined. Based on the design's dimensional restraints, an optimum compromise between the number and size of the output capacitors can be reached. Conservative approaches dictate using the data book's maximum values for ESR; this way the design will still meet the initial criteria even at the end of capacitor's active life. High frequency decoupling of the output may not be implemented if the application provides high frequency decoupling components at the load end of the output. In applications requiring good high frequency decoupling, the output should be accordingly decoupled using a few ceramic capacitors. This measure is especially necessary if high ESL output capacitors are used.

### Output Inductor Selection

The output inductor is selected to meet the output voltage ripple requirements and minimize the converter's response time to the load transient. The inductor value determines the converter's ripple current and the ripple voltage is a function of the ripple current. Increasing the value of inductance reduces the ripple current and voltage. However, the large inductance values reduce the converter's response time to a load transient. One of the parameters limiting the converter's response to a load transient is the time required to change the inductor current from an initial current value to the transient current level. During this interval the difference between the inductor current and the transient current level must be supplied by the output capacitor. Minimizing the response time can minimize the output capacitance required.

### **Output Ripple Voltage**

The amount of ripple voltage on the output of the DC-DC converter varies with, switching frequency, output inductor, and output capacitors.

### **Output Load Transient Response**

The application of a sudden load requiring the converter to supply maximum output current, most of the energy required by the output load is initially delivered from the output capacitors. This is due to the finite amount of time required for the inductor current to slew up to the level of output current

required by the load, and results in a temporary dip ( $\Delta V_{LOW}$ ) in the output voltage, see Figure 7. Conversely, a sudden removal of the same output load, the energy stored in the inductor is dumped into the output capacitors, creating a temporary hump ( $\Delta V_{HIGH}$ ) in the output voltage.

### **Conclusion**

The ISL6160EVAL2 board lends itself well to the evaluation of a complete single fixed voltage IB Class I power supply and providing a conceptual platform for your specific IM power control and supply needs.

In addition, with the availability of multiple output voltage converters such as the IPM6220A coupled with the ISL6160, Intersil provides an application solution for almost every InfiniBand I/O module.

### **References**

For Intersil documents available on the web, see <http://www.intersil.com/>

- [1] *ISL6160 Data Sheet*, Intersil Corporation, FN9028
- [2] *HIP6006 Data Sheet*, Intersil Corporation, FN4306.
- [3] *IPM6220A Data Sheet*, Intersil Corporation, FN9032
- [4] *Application Note*, Intersil Corporation, AN9722.
- [5] *Application Note*, Intersil Corporation, AN9761

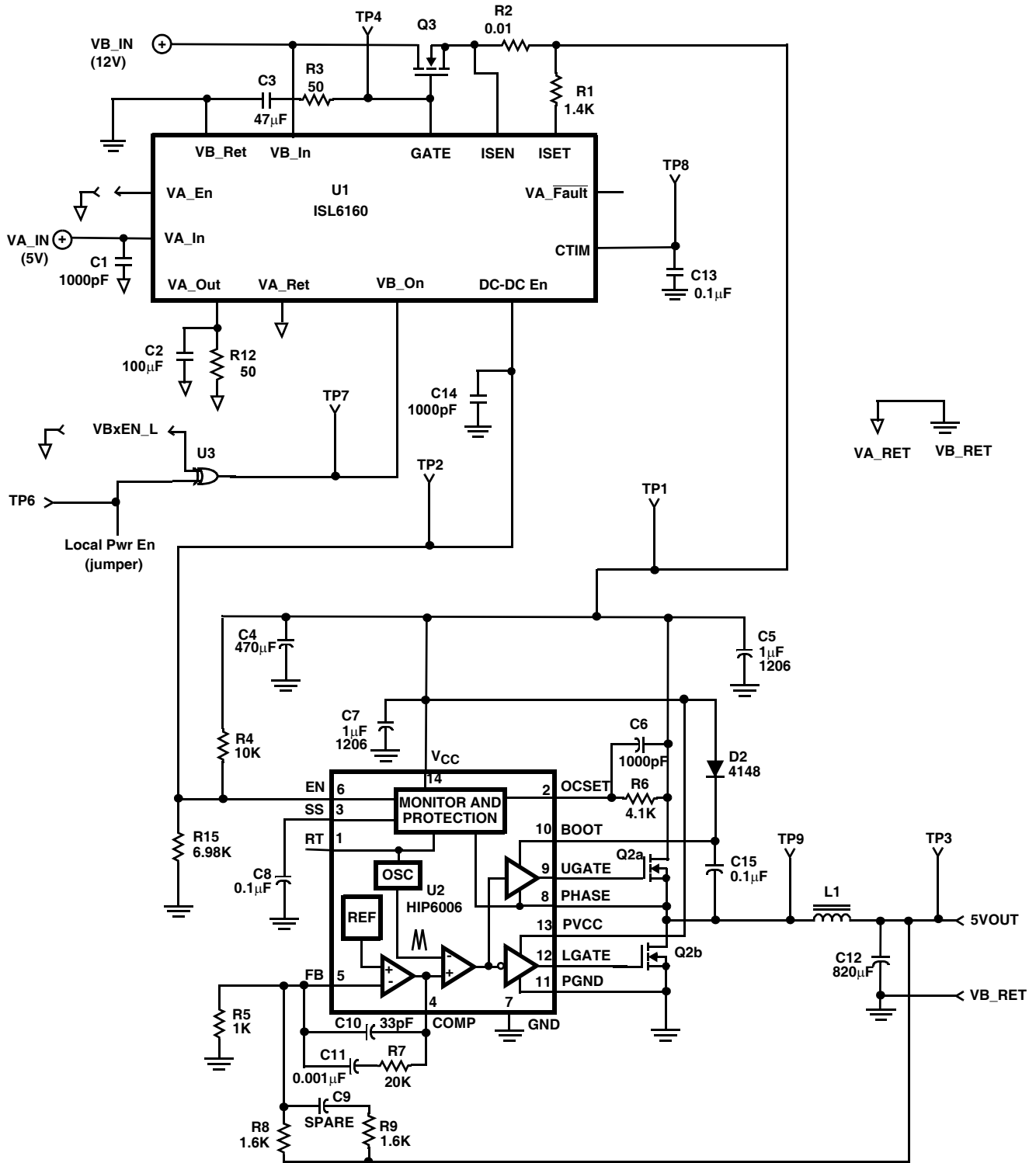

FIGURE 11. ISL6160EVAL2 SCHEMATIC

**Bill of Materials for HIP6006EVAL1**

PART #	DESCRIPTION	PACKAGE	QTY	REF	VENDOR
ISL6160IB	InfiniBand Power Controller	14NSOIC	1	U1	INTERSIL
HIP6006CV	Synchronous Rectified Buck Controller	14TSSOP	1	U2	INTERSIL
SN74AHC1G86 or equiv	Single XOR gate	5SOT-23	1	U3	Various
Si4922DY or equiv	Dual 8A, 30V, 0.018Ω, N-Channel MOSFET	8SOIC	1	Q2	Various
ITF86130SK8T or equiv	14A, 40V, 0.008Ω, N-Channel MOSFET	8SOIC	1	Q3	Various
1N4148	Rectifier, 100mA, 75V	DO35	1	D2	Various
10μH	Output Filter Inductor	Wound Toroid	1	L1	Various
1.4K	VB Current Set Resistor, 1%, 1/16W	0603	1	R1	Various
0.01Ω	VB Current Sense Resistor, 1%, 1W	2512	1	R2	Various
50Ω	SMD Resistor, 5%, 1/16W	0603	2	R3, R10	Various
10KΩ	SMD Resistor, 5%, 1/16W	0603	1	R4	Various
1KΩ	SMD Resistor, 5%, 1/16W	0603	1	R5	Various
4.1Ω	SMD Resistor, 5%, 1/16W	0603	1	R6	Various
20KΩ	SMD Resistor, 5%, 1/16W	0603	1	R7	Various
3.0KΩ	SMD Resistor, 5%, 1/16W	0603	1	R8	Various
DNP	SMD Resistor, 5%, 1/16W	0603	1	R9	Various
50Ω	Through hole Resistor, 5%, 1W	-	1	R12	Various
6.98KΩ	SMD Resistor, 5%, 1/10W	0805	1	R15	Various
100μF	Electrolytic Aluminum Capacitor, 16V	Radial	1	C2	Various
470μF	Electrolytic Aluminum Capacitor, 16V	Radial	1	C4	Various
820μF	Electrolytic Aluminum Capacitor, 16V	Radial	1	C12	Various
1000pF	Ceramic Capacitor, 50V	0603	2	C1, C6, C14	Various
47μF	Ceramic Capacitor, 50V	0603	1	C3	Various
1μF	Ceramic Capacitor, 50V	0603	2	C5, C7	Various
0.1μF	Ceramic Capacitor, 50V	0603	2	C8, C13, C15	Various
33pF	Ceramic Capacitor, 50V	0603	1	C10	Various
0.001μF	Ceramic Capacitor, 50V	0603	1	C11	Various
-	Local power enable Jumper	-	1	PWR_EN	Various
-	Test Points	-	9	TP1- TP9	Various
1314353-00	Scope Probe Test Point	-	1	TP3, VOUT	Tektronics
-	Banana Jacks	-	4	VB_IN, VA_IN, VB_RET, VA_RET	Various
EZM06DRXH	Edge Connector	-	1	-	Sullins

## Notice

1. Descriptions of circuits, software and other related information in this document are provided only to illustrate the operation of semiconductor products and application examples. You are fully responsible for the incorporation or any other use of the circuits, software, and information in the design of your product or system. Renesas Electronics disclaims any and all liability for any losses and damages incurred by you or third parties arising from the use of these circuits, software, or information.
2. Renesas Electronics hereby expressly disclaims any warranties against and liability for infringement or any other claims involving patents, copyrights, or other intellectual property rights of third parties, by or arising from the use of Renesas Electronics products or technical information described in this document, including but not limited to, the product data, drawings, charts, programs, algorithms, and application examples.
3. No license, express, implied or otherwise, is granted hereby under any patents, copyrights or other intellectual property rights of Renesas Electronics or others.
4. You shall not alter, modify, copy, or reverse engineer any Renesas Electronics product, whether in whole or in part. Renesas Electronics disclaims any and all liability for any losses or damages incurred by you or third parties arising from such alteration, modification, copying or reverse engineering.
5. Renesas Electronics products are classified according to the following two quality grades: "Standard" and "High Quality". The intended applications for each Renesas Electronics product depends on the product's quality grade, as indicated below.  
"Standard": Computers; office equipment; communications equipment; test and measurement equipment; audio and visual equipment; home electronic appliances; machine tools; personal electronic equipment; industrial robots; etc.  
"High Quality": Transportation equipment (automobiles, trains, ships, etc.); traffic control (traffic lights); large-scale communication equipment; key financial terminal systems; safety control equipment; etc.  
Unless expressly designated as a high reliability product or a product for harsh environments in a Renesas Electronics data sheet or other Renesas Electronics document, Renesas Electronics products are not intended or authorized for use in products or systems that may pose a direct threat to human life or bodily injury (artificial life support devices or systems; surgical implantations; etc.), or may cause serious property damage (space system; undersea repeaters; nuclear power control systems; aircraft control systems; key plant systems; military equipment; etc.). Renesas Electronics disclaims any and all liability for any damages or losses incurred by you or any third parties arising from the use of any Renesas Electronics product that is inconsistent with any Renesas Electronics data sheet, user's manual or other Renesas Electronics document.
6. When using Renesas Electronics products, refer to the latest product information (data sheets, user's manuals, application notes, "General Notes for Handling and Using Semiconductor Devices" in the reliability handbook, etc.), and ensure that usage conditions are within the ranges specified by Renesas Electronics with respect to maximum ratings, operating power supply voltage range, heat dissipation characteristics, installation, etc. Renesas Electronics disclaims any and all liability for any malfunctions, failure or accident arising out of the use of Renesas Electronics products outside of such specified ranges.
7. Although Renesas Electronics endeavors to improve the quality and reliability of Renesas Electronics products, semiconductor products have specific characteristics, such as the occurrence of failure at a certain rate and malfunctions under certain use conditions. Unless designated as a high reliability product or a product for harsh environments in a Renesas Electronics data sheet or other Renesas Electronics document, Renesas Electronics products are not subject to radiation resistance design. You are responsible for implementing safety measures to guard against the possibility of bodily injury, injury or damage caused by fire, and/or danger to the public in the event of a failure or malfunction of Renesas Electronics products, such as safety design for hardware and software, including but not limited to redundancy, fire control and malfunction prevention, appropriate treatment for aging degradation or any other appropriate measures. Because the evaluation of microcomputer software alone is very difficult and impractical, you are responsible for evaluating the safety of the final products or systems manufactured by you.
8. Please contact a Renesas Electronics sales office for details as to environmental matters such as the environmental compatibility of each Renesas Electronics product. You are responsible for carefully and sufficiently investigating applicable laws and regulations that regulate the inclusion or use of controlled substances, including without limitation, the EU RoHS Directive, and using Renesas Electronics products in compliance with all these applicable laws and regulations. Renesas Electronics disclaims any and all liability for damages or losses occurring as a result of your noncompliance with applicable laws and regulations.
9. Renesas Electronics products and technologies shall not be used for or incorporated into any products or systems whose manufacture, use, or sale is prohibited under any applicable domestic or foreign laws or regulations. You shall comply with any applicable export control laws and regulations promulgated and administered by the governments of any countries asserting jurisdiction over the parties or transactions.
10. It is the responsibility of the buyer or distributor of Renesas Electronics products, or any other party who distributes, disposes of, or otherwise sells or transfers the product to a third party, to notify such third party in advance of the contents and conditions set forth in this document.
11. This document shall not be reprinted, reproduced or duplicated in any form, in whole or in part, without prior written consent of Renesas Electronics.
12. Please contact a Renesas Electronics sales office if you have any questions regarding the information contained in this document or Renesas Electronics products.  
(Note 1) "Renesas Electronics" as used in this document means Renesas Electronics Corporation and also includes its directly or indirectly controlled subsidiaries.  
(Note 2) "Renesas Electronics product(s)" means any product developed or manufactured by or for Renesas Electronics.

(Rev.4.0-1 November 2017)



### SALES OFFICES

Renesas Electronics Corporation

<http://www.renesas.com>

Refer to "<http://www.renesas.com/>" for the latest and detailed information.

**Renesas Electronics America Inc.**  
1001 Murphy Ranch Road, Milpitas, CA 95035, U.S.A.  
Tel: +1-408-432-8888, Fax: +1-408-434-5351

**Renesas Electronics Canada Limited**  
9251 Yonge Street, Suite 8309 Richmond Hill, Ontario Canada L4C 9T3  
Tel: +1-905-237-2004

**Renesas Electronics Europe Limited**  
Dukes Meadow, Millboard Road, Bourne End, Buckinghamshire, SL8 5FH, U.K  
Tel: +44-1628-651-700, Fax: +44-1628-651-804

**Renesas Electronics Europe GmbH**  
Arcadiastrasse 10, 40472 Düsseldorf, Germany  
Tel: +49-211-6503-0, Fax: +49-211-6503-1327

**Renesas Electronics (China) Co., Ltd.**  
Room 1709 Quantum Plaza, No.27 ZhichunLu, Haidian District, Beijing, 100191 P. R. China  
Tel: +86-10-8235-1155, Fax: +86-10-8235-7679

**Renesas Electronics (Shanghai) Co., Ltd.**  
Unit 301, Tower A, Central Towers, 555 Langao Road, Putuo District, Shanghai, 200333 P. R. China  
Tel: +86-21-2226-0888, Fax: +86-21-2226-0999

**Renesas Electronics Hong Kong Limited**  
Unit 1601-1611, 16/F., Tower 2, Grand Century Place, 193 Prince Edward Road West, Mongkok, Kowloon, Hong Kong  
Tel: +852-2265-6688, Fax: +852-2886-9022

**Renesas Electronics Taiwan Co., Ltd.**  
13F, No. 363, Fu Shing North Road, Taipei 10543, Taiwan  
Tel: +886-2-8175-9600, Fax: +886-2-8175-9670

**Renesas Electronics Singapore Pte. Ltd.**  
80 Bendemeer Road, Unit #06-02 Hyflux Innovation Centre, Singapore 339949  
Tel: +65-6213-0200, Fax: +65-6213-0300

**Renesas Electronics Malaysia Sdn.Bhd.**  
Unit 1207, Block B, Menara Amcorp, Amcorp Trade Centre, No. 18, Jln Persiaran Barat, 46050 Petaling Jaya, Selangor Darul Ehsan, Malaysia  
Tel: +60-3-7955-9390, Fax: +60-3-7955-9510

**Renesas Electronics India Pvt. Ltd.**  
No.777C, 100 Feet Road, HAL 2nd Stage, Indiranagar, Bangalore 560 038, India  
Tel: +91-80-67208700, Fax: +91-80-67208777

**Renesas Electronics Korea Co., Ltd.**  
17F, KAMCO Yangjae Tower, 262, Gangnam-daero, Gangnam-gu, Seoul, 06265 Korea  
Tel: +82-2-558-3737, Fax: +82-2-558-5338