

Noise Component Role in Forming Image Quality

SLG51003V

This application note describes the role of the noise component which can affect the quality of an image when using an image sensor. It explains how engineers can maintain system performance and improve image quality using the SLG51003V Power GreenPAK IC which features High PSRR, Low Noise, and Multi-output LDOs.

Contents

1. Introduction	2
2. Establishing the Test Bench and Methodology.....	3
3. Image Quality Analysis	4
4. Conclusion	7
5. Revision History	8

Terms and Definitions

AV/VR	Augmented Reality/Virtual Reality
EPS	Embedded Power Supply
LDO	Low-dropout Regulator
PMIC	Power Management Integrated Circuits
PSRR	Power Supply Rejection Ratio
SNR	Signal-to-noise Ratio

References

For related documents and software, please visit:

[Power GreenPAK™ | Renesas](#)

Download our free GreenPAK Designer software (Go Configure Software Hub) [1] to open the .ppak file [2] and view the proposed circuit design. Use the GreenPAK development tools [3] to freeze the design into your own customized IC in a matter of minutes. Renesas Electronics provides a complete library of application notes [4] featuring design examples, as well as explanations of features and blocks within the Renesas IC.

- [1] [GreenPAK Go Configure Software Hub](#), Software Download and User Guide, Renesas Electronics
- [2] [AN-CM-400 Noise Component Role in Forming Image Quality](#), Power GreenPAK Design File & Image and Waveform Datasets, Renesas Electronics
- [3] [GreenPAK Development Tools](#), GreenPAK Development Tools Webpage, Renesas Electronics
- [4] [GreenPAK Application Notes](#), GreenPAK Application Notes Webpage, Renesas Electronics
- [5] [Power GreenPAK](#), Power GreenPAK Webpage, Renesas Electronics
- [6] [Raspberry Pi 4](#), Single-board computer Webpage, Raspberry Pi Foundation
- [7] [Camera module V2](#), Camera module with 8-megapixel sensor Webpage, Raspberry Pi Foundation
- [8] [Camera module V2 Schematic](#), Electrical Schematic, Raspberry Pi Foundation
- [9] [SLG51003V Datasheet](#), SLG51003V Datasheet, Renesas Electronics
- [10] [AN-CM-399 Enhancing LDO PSRR and Noise Performance Measurements using Capacitors with Low Parasitic Parameters](#), Application Note, Renesas Electronics

Author: Denys Levchunets, Application Engineer, Renesas Electronics

1. Introduction

In applications involving image sensors (such as digital cameras, mobile phones, AR/VR systems, robots, and other similar technologies) power supply noise can significantly impact image quality when capturing an image, often causing pixel artifacts or causing the signal-to-noise ratio (SNR) degradation. Figure 1 illustrates the typical architecture of a camera application where the image sensor is the primary component. The image sensor is powered by multiple voltage rails and includes a high-speed digital component.

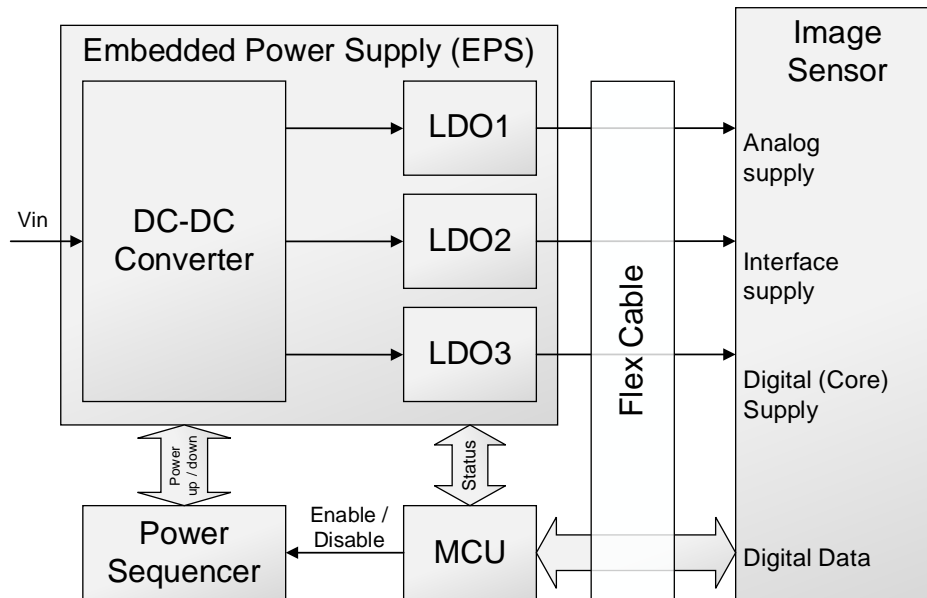

Figure 1: Typical Architecture of a Camera Application

To ensure high-quality image output, it is essential to provide a stable power supply across the sensor's multiple rails. Several potential issues should be considered during the design phase to mitigate power supply noise. Key sources of noise in applications using an image sensor (or other advanced sensor components) include:

- Insufficient power supply filtering
- Power supply ripple
- Ground loop noise
- Crosstalk and electromagnetic interference (EMI)
- Digital circuit noise
- Transient load variations
- Temperature-induced noise
- Cable and connector noise
- Noise from motor drivers, if present

The Embedded Power Supply (EPS) plays a critical role in filtering and delivering clean power to the image sensor. Additionally, the analog supply rail can have a significant impact on overall system performance and thus requires additional design considerations. In some cases, power supply ripple can even originate from the EPS itself (as shown in Figure 1). For example, while DC-DC converters are efficient, they also generate switching noise which can be problematic. To mitigate this, low-dropout regulators (LDOs) are commonly used in the EPS.

LDOs are cost-effective and efficient components, capable of filtering out much of the system noise. However, discrete LDOs can also be replaced by power management integrated circuits (PMICs), which offer several advantages such as reduced PCB footprint, built-in power sequencing, status monitoring, and cost savings. Renesas Electronics has a broad portfolio of PMICs that take advantage of these features (see more [here](#)).

2. Establishing the Test Bench and Methodology

To demonstrate the impact of power supply noise on overall system performance (specifically on the data obtained from the image sensor) a test bench was utilized. The test bench, illustrated in Figure 2, mainly consists of two commonly available commercial components:

1. [Raspberry Pi 4](#) - serves as a base computing platform for test bench[3].
2. [Camera module V2](#) – an "out-of-the-box" solution tailored for the Raspberry PI platform.

To assess the role of noise in determining image quality, modifications were made to the Camera module. As previously stated, the analog supply rail plays a critical role in system performance. Accordingly, the analog rail LDO input power supply (denoted as V_{supply} in Figure 2) is rerouted from the Raspberry Pi 4 to laboratory equipment which allows for controlled noise injection into the system for further analysis.

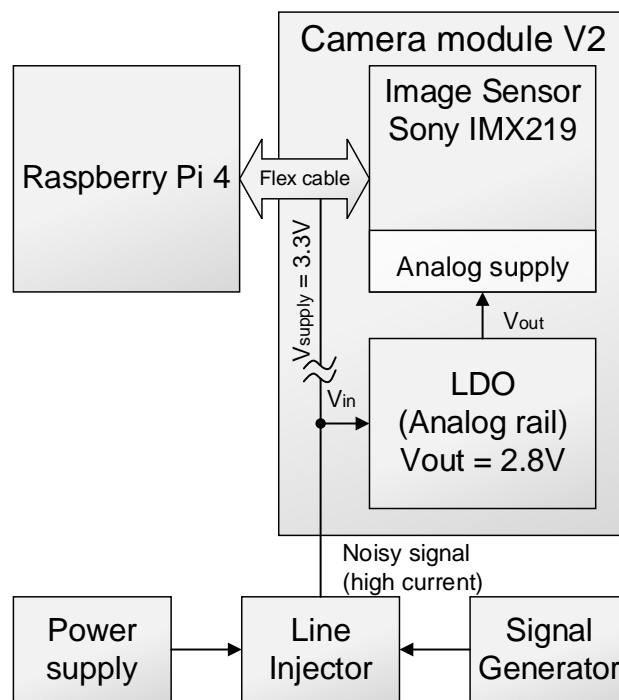

Figure 2: Test Bench Block Diagram

As shown in the camera module schematic [8], the AP7331-28WG is the default LDO solution for the analog rail (2.8 V) in Camera module V2.

The Renesas SLG51003V is used as an alternative solution. This PMIC with a high Power Supply Rejection Ratio (PSRR), Low Noise, and Multi-output LDOs (3 in total), is specifically designed for applications involving image sensors (or other types of advanced sensors).

In image sensor applications, maintaining a high PSRR is essential for ensuring clean and stable power to sensitive analog and digital circuits. This is particularly important in the high-frequency range (such as at 1 MHz) where switching noise from DC-DC converters, digital circuits, and other system components is more prevalent.

For example, in Figure 3, the comparison of the PSRR performance between the default LDO and SLG51003V (LDO_HP) highlights the superior noise suppression capabilities of the latter at higher frequencies. This becomes particularly relevant as systems operate at higher clock speeds and involve fast-switching circuits, which are more prone to generating noise.

The application note, [AN-CM-399 Enhancing LDO PSRR and Noise performance measurements with Low Parasitic parameters capacitors](#), reveals additional info about LDO performance.

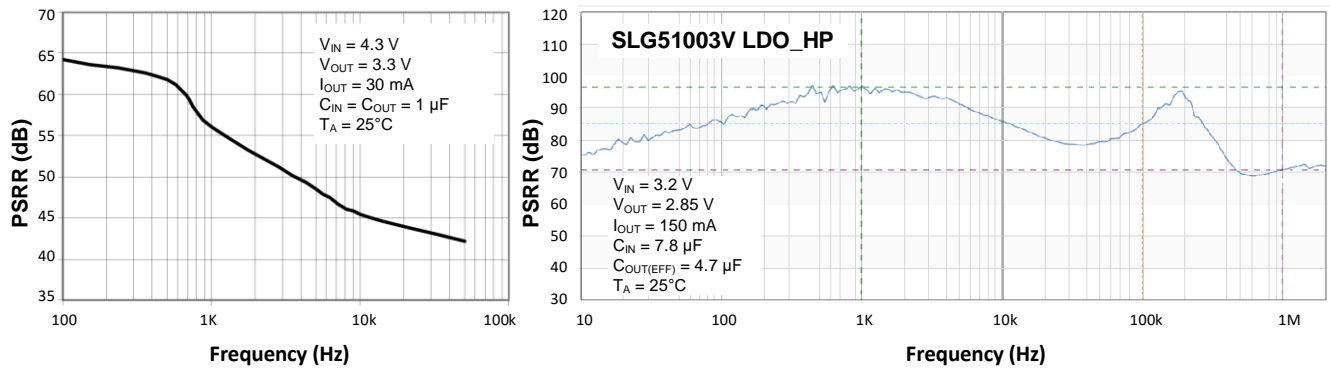

Figure 3: PSRR Performance Comparison AP7331 vs SLG51003V (LDO_HP)

For the experiment to yield accurate data, the Camera module is placed in a laboratory-controlled environment with constant light intensity and a stationary scene. Figure 4 illustrates the bench setup, where the Raspberry Pi 4 is used in conjunction with the modified Camera module. This setup ensures that any external variables are minimized, allowing for precise observation of noise effects on the image sensor's performance.



Figure 4: Bench Setup with Modified Camera Module V2

Establishing the Test Bench provides a controlled method for evaluating the influence of power supply noise on image quality. The comparison between the PSRR performance of the default LDO and of the SLG51003V highlights the importance of selecting a proper power management solution to use in noise-sensitive applications. These findings lay the foundation for the subsequent chapter, which will focus on a detailed analysis of the quality of the obtained images and sensor data.

3. Image Quality Analysis

To ensure a direct and fair comparison between the two camera module PCBs (one using the default LDO and the other using the proposed SLG51003V) the following steps were followed for both configurations to ensure consistency:

1. Identical input and output capacitors were used for both LDOs, with the exact same type of capacitor and identical values ($C_{IN} = 10 \text{ nF}$; $C_{OUT} = 4.7 \text{ μF}$).
2. The same image sensor (Sony IMX219) was used in both setups.
3. The noise type introduced to the LDOs' input (V_{in}) was quasi-white noise, with a 100 MHz passband.

Noise Component Role in Forming Image Quality

The raw image captures reveal clear differences in LDO performance. Particularly, [Figure 5](#) shows the results obtained using the default LDO under V_{in} noise conditions. The image exhibits noticeable noise artifacts, manifested as horizontal superimposed RGB-colored lines. This noise is introduced by the LDO's inability to sufficiently filter out high-frequency noise at the input.

In contrast, [Figure 6](#), which represents similar capture conditions but powered by the SLG51003V, shows a significant improvement. The RGB noise artifacts present in the previous image are absent, demonstrating that SLG51003V's superior noise rejection capabilities, effectively mitigate the power supply noise and create a clearer image.

Further data was collected in a completely dark environment, where no external light was present to influence the image sensor. [Figure 7](#) displays the distribution of RGB color components under the influence of LDO input noise. Initially, both the default LDO and SLG51003V both show a small amount of background noise in the RGB channels - about 0.6% of the signal originates from the inherent noise of the image sensor itself, which is expected in dark conditions.

As the input noise (RMS ripple) is increased, a significant difference in image corruption between the two LDOs emerges. The default LDO exhibits an exponential rise in the percentage of RGB noise components once the input noise exceeds 320 mV RMS ripple. This increase indicates that the default LDO was unable to adequately filter higher levels of input noise, leading to significant image degradation. When the RGB noise level reaches ~4%, the image suffers from severe distortion, causing unacceptable levels of image corruption.

On the other hand, the SLG51003V shows far better performance under the same noise conditions. Its high PSRR capabilities allow it to maintain a much lower level of RGB component interference, even as the noise level is increased.

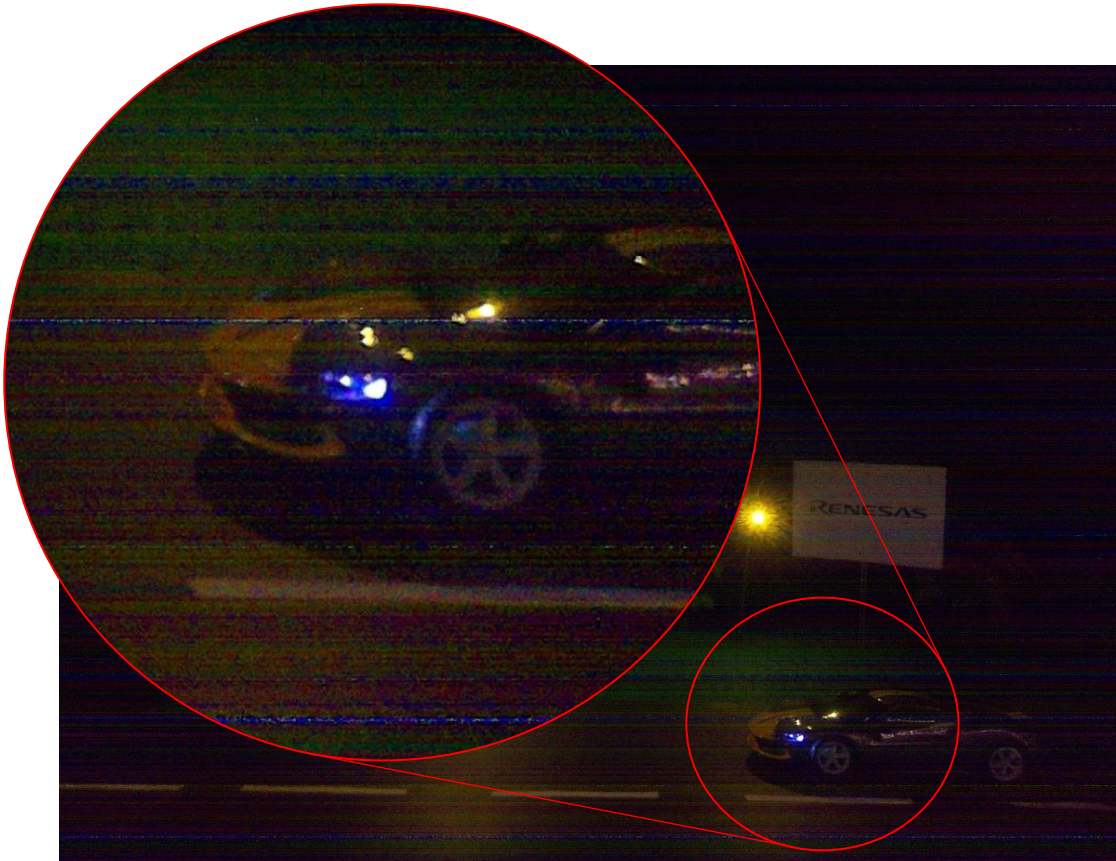

Figure 5: Image capture using AP7331-28WG when Vin noise (RMS ripple) is 326 mV

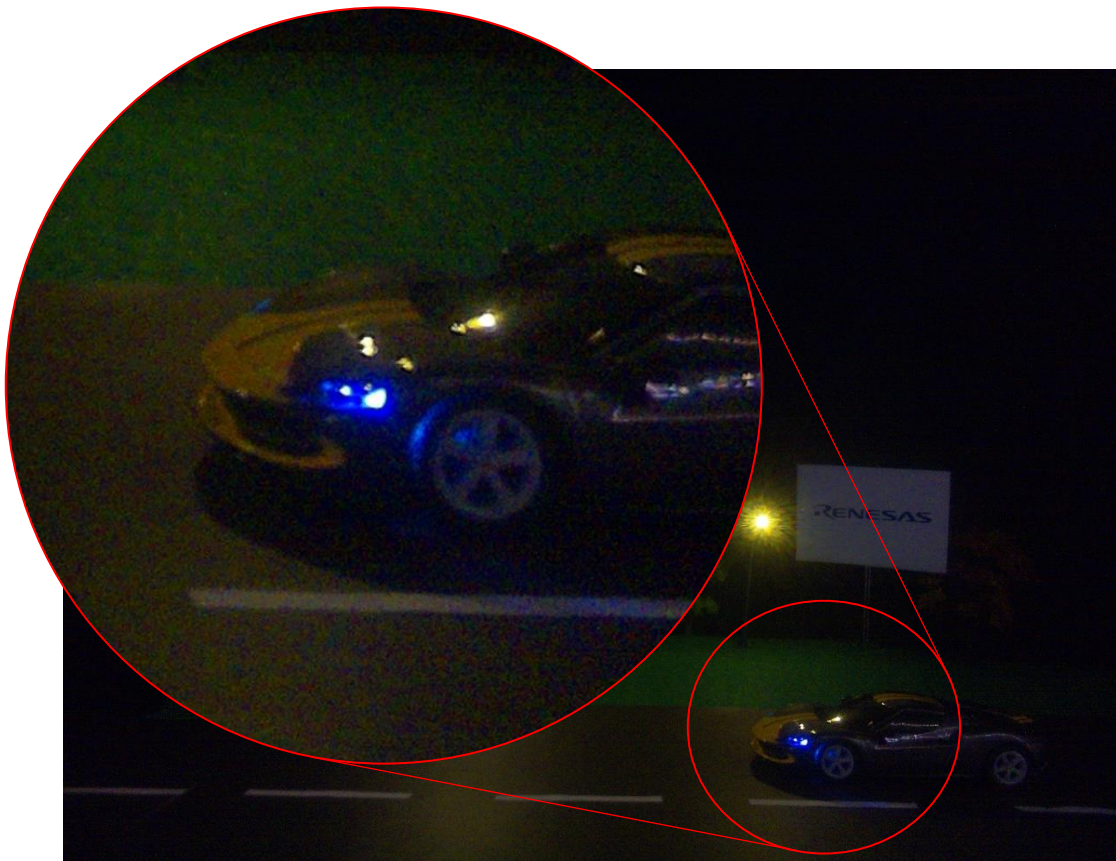

Figure 6: Image capture using SLG51003V when LDO_HP Vin noise (RMS ripple) is 354 mV

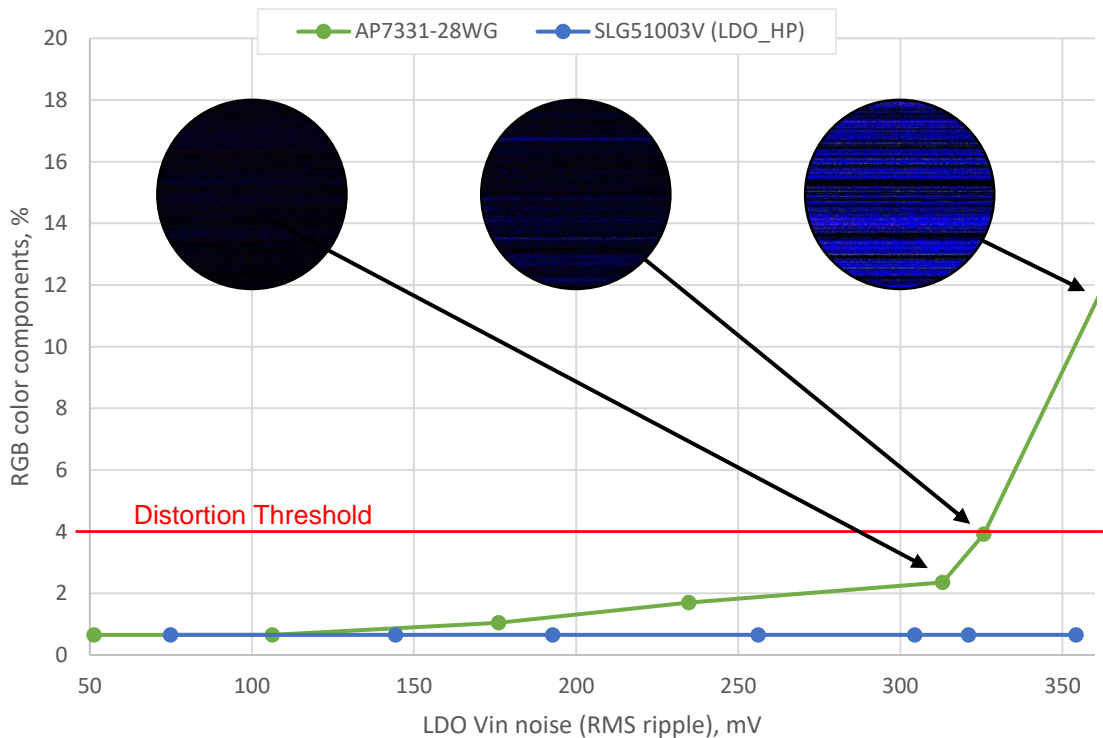

Figure 7: RGB Color component distribution, generated by LDO Vin noise

Obtained datasets available by the following [link](#).

4. Conclusion

In image sensor applications, power supply noise can significantly degrade image quality, leading to visual issues in the images generated. Choosing the right power management solution is crucial to maintaining clean, high-quality images. The **SLG51003V** Power GreenPAK IC, offers high PSRR (of 98.5 dB at 1 kHz and 68 dB at 1 MHz for LDO_HP), Low Noise (16 μ V LDO_HP), and Multi-output LDOs.

In a controlled laboratory environment testing, the SLG51003V demonstrates its clear advantage in a simulation of a noisy system. Clean, sharp images were obtained by effectively filtering out noise that would otherwise create visible artifacts such as RGB-colored lines, ensuring that the system consistently captures high-quality images, even under difficult conditions.

By integrating the SLG51003V LDO IC into your design, you can enhance system performance, protect image quality, and ensure that your products stand out in competitive markets where reliability and precision are critical. It also provides additional Power GreenPAK benefits, such as high configurability, status and report indicators, programmable scenarios and sequencing, GPIOs, and the I²C interface support.

5. Revision History

Revision	Date	Description
1.00	Oct 18, 2024	Initial version.