

To our customers,

Old Company Name in Catalogs and Other Documents

On April 1st, 2010, NEC Electronics Corporation merged with Renesas Technology Corporation, and Renesas Electronics Corporation took over all the business of both companies. Therefore, although the old company name remains in this document, it is a valid Renesas Electronics document. We appreciate your understanding.

Renesas Electronics website: <http://www.renesas.com>

April 1st, 2010
Renesas Electronics Corporation

Issued by: Renesas Electronics Corporation (<http://www.renesas.com>)

Send any inquiries to <http://www.renesas.com/inquiry>.

Notice

1. All information included in this document is current as of the date this document is issued. Such information, however, is subject to change without any prior notice. Before purchasing or using any Renesas Electronics products listed herein, please confirm the latest product information with a Renesas Electronics sales office. Also, please pay regular and careful attention to additional and different information to be disclosed by Renesas Electronics such as that disclosed through our website.
2. Renesas Electronics does not assume any liability for infringement of patents, copyrights, or other intellectual property rights of third parties by or arising from the use of Renesas Electronics products or technical information described in this document. No license, express, implied or otherwise, is granted hereby under any patents, copyrights or other intellectual property rights of Renesas Electronics or others.
3. You should not alter, modify, copy, or otherwise misappropriate any Renesas Electronics product, whether in whole or in part.
4. Descriptions of circuits, software and other related information in this document are provided only to illustrate the operation of semiconductor products and application examples. You are fully responsible for the incorporation of these circuits, software, and information in the design of your equipment. Renesas Electronics assumes no responsibility for any losses incurred by you or third parties arising from the use of these circuits, software, or information.
5. When exporting the products or technology described in this document, you should comply with the applicable export control laws and regulations and follow the procedures required by such laws and regulations. You should not use Renesas Electronics products or the technology described in this document for any purpose relating to military applications or use by the military, including but not limited to the development of weapons of mass destruction. Renesas Electronics products and technology may not be used for or incorporated into any products or systems whose manufacture, use, or sale is prohibited under any applicable domestic or foreign laws or regulations.
6. Renesas Electronics has used reasonable care in preparing the information included in this document, but Renesas Electronics does not warrant that such information is error free. Renesas Electronics assumes no liability whatsoever for any damages incurred by you resulting from errors in or omissions from the information included herein.
7. Renesas Electronics products are classified according to the following three quality grades: “Standard”, “High Quality”, and “Specific”. The recommended applications for each Renesas Electronics product depends on the product’s quality grade, as indicated below. You must check the quality grade of each Renesas Electronics product before using it in a particular application. You may not use any Renesas Electronics product for any application categorized as “Specific” without the prior written consent of Renesas Electronics. Further, you may not use any Renesas Electronics product for any application for which it is not intended without the prior written consent of Renesas Electronics. Renesas Electronics shall not be in any way liable for any damages or losses incurred by you or third parties arising from the use of any Renesas Electronics product for an application categorized as “Specific” or for which the product is not intended where you have failed to obtain the prior written consent of Renesas Electronics. The quality grade of each Renesas Electronics product is “Standard” unless otherwise expressly specified in a Renesas Electronics data sheets or data books, etc.
 - “Standard”: Computers; office equipment; communications equipment; test and measurement equipment; audio and visual equipment; home electronic appliances; machine tools; personal electronic equipment; and industrial robots.
 - “High Quality”: Transportation equipment (automobiles, trains, ships, etc.); traffic control systems; anti-disaster systems; anti-crime systems; safety equipment; and medical equipment not specifically designed for life support.
 - “Specific”: Aircraft; aerospace equipment; submersible repeaters; nuclear reactor control systems; medical equipment or systems for life support (e.g. artificial life support devices or systems), surgical implantations, or healthcare intervention (e.g. excision, etc.), and any other applications or purposes that pose a direct threat to human life.
8. You should use the Renesas Electronics products described in this document within the range specified by Renesas Electronics, especially with respect to the maximum rating, operating supply voltage range, movement power voltage range, heat radiation characteristics, installation and other product characteristics. Renesas Electronics shall have no liability for malfunctions or damages arising out of the use of Renesas Electronics products beyond such specified ranges.
9. Although Renesas Electronics endeavors to improve the quality and reliability of its products, semiconductor products have specific characteristics such as the occurrence of failure at a certain rate and malfunctions under certain use conditions. Further, Renesas Electronics products are not subject to radiation resistance design. Please be sure to implement safety measures to guard them against the possibility of physical injury, and injury or damage caused by fire in the event of the failure of a Renesas Electronics product, such as safety design for hardware and software including but not limited to redundancy, fire control and malfunction prevention, appropriate treatment for aging degradation or any other appropriate measures. Because the evaluation of microcomputer software alone is very difficult, please evaluate the safety of the final products or system manufactured by you.
10. Please contact a Renesas Electronics sales office for details as to environmental matters such as the environmental compatibility of each Renesas Electronics product. Please use Renesas Electronics products in compliance with all applicable laws and regulations that regulate the inclusion or use of controlled substances, including without limitation, the EU RoHS Directive. Renesas Electronics assumes no liability for damages or losses occurring as a result of your noncompliance with applicable laws and regulations.
11. This document may not be reproduced or duplicated, in any form, in whole or in part, without prior written consent of Renesas Electronics.
12. Please contact a Renesas Electronics sales office if you have any questions regarding the information contained in this document or Renesas Electronics products, or if you have any other inquiries.

(Note 1) “Renesas Electronics” as used in this document means Renesas Electronics Corporation and also includes its majority-owned subsidiaries.

(Note 2) “Renesas Electronics product(s)” means any product developed or manufactured by or for Renesas Electronics.

M66596FP Utility Board M3A-0039 Instruction Manual

Notes regarding these materials

1. This document is provided for reference purposes only so that Renesas customers may select the appropriate Renesas products for their use. Renesas neither makes warranties or representations with respect to the accuracy or completeness of the information contained in this document nor grants any license to any intellectual property rights or any other rights of Renesas or any third party with respect to the information in this document.
2. Renesas shall have no liability for damages or infringement of any intellectual property or other rights arising out of the use of any information in this document, including, but not limited to, product data, diagrams, charts, programs, algorithms, and application circuit examples.
3. You should not use the products or the technology described in this document for the purpose of military applications such as the development of weapons of mass destruction or for the purpose of any other military use. When exporting the products or technology described herein, you should follow the applicable export control laws and regulations, and procedures required by such laws and regulations.
4. All information included in this document such as product data, diagrams, charts, programs, algorithms, and application circuit examples, is current as of the date this document is issued. Such information, however, is subject to change without any prior notice. Before purchasing or using any Renesas products listed in this document, please confirm the latest product information with a Renesas sales office. Also, please pay regular and careful attention to additional and different information to be disclosed by Renesas such as that disclosed through our website. (<http://www.renesas.com>)
5. Renesas has used reasonable care in compiling the information included in this document, but Renesas assumes no liability whatsoever for any damages incurred as a result of errors or omissions in the information included in this document.
6. When using or otherwise relying on the information in this document, you should evaluate the information in light of the total system before deciding about the applicability of such information to the intended application. Renesas makes no representations, warranties or guaranties regarding the suitability of its products for any particular application and specifically disclaims any liability arising out of the application and use of the information in this document or Renesas products.
7. With the exception of products specified by Renesas as suitable for automobile applications, Renesas products are not designed, manufactured or tested for applications or otherwise in systems the failure or malfunction of which may cause a direct threat to human life or create a risk of human injury or which require especially high quality and reliability such as safety systems, or equipment or systems for transportation and traffic, healthcare, combustion control, aerospace and aeronautics, nuclear power, or undersea communication transmission. If you are considering the use of our products for such purposes, please contact a Renesas sales office beforehand. Renesas shall have no liability for damages arising out of the uses set forth above.
8. Notwithstanding the preceding paragraph, you should not use Renesas products for the purposes listed below:
 - (1) artificial life support devices or systems
 - (2) surgical implantations
 - (3) healthcare intervention (e.g., excision, administration of medication, etc.)
 - (4) any other purposes that pose a direct threat to human lifeRenesas shall have no liability for damages arising out of the uses set forth in the above and purchasers who elect to use Renesas products in any of the foregoing applications shall indemnify and hold harmless Renesas Technology Corp., its affiliated companies and their officers, directors, and employees against any and all damages arising out of such applications.
9. You should use the products described herein within the range specified by Renesas, especially with respect to the maximum rating, operating supply voltage range, movement power voltage range, heat radiation characteristics, installation and other product characteristics. Renesas shall have no liability for malfunctions or damages arising out of the use of Renesas products beyond such specified ranges.
10. Although Renesas endeavors to improve the quality and reliability of its products, IC products have specific characteristics such as the occurrence of failure at a certain rate and malfunctions under certain use conditions. Please be sure to implement safety measures to guard against the possibility of physical injury, and injury or damage caused by fire in the event of the failure of a Renesas product, such as safety design for hardware and software including but not limited to redundancy, fire control and malfunction prevention, appropriate treatment for aging degradation or any other applicable measures. Among others, since the evaluation of microcomputer software alone is very difficult, please evaluate the safety of the final products or system manufactured by you.
11. In case Renesas products listed in this document are detached from the products to which the Renesas products are attached or affixed, the risk of accident such as swallowing by infants and small children is very high. You should implement safety measures so that Renesas products may not be easily detached from your products. Renesas shall have no liability for damages arising out of such detachment.
12. This document may not be reproduced or duplicated, in any form, in whole or in part, without prior written approval from Renesas.
13. Please contact a Renesas sales office if you have any questions regarding the information contained in this document, Renesas semiconductor products, or if you have any other inquiries.

CONTENTS

1. Summary.....	1
2. Outline	1
3. Specification	1
3.1. Connector Description.....	2
4. Jumper and Switch Setting.....	3
5. Setup.....	4
5.1. Using with M3A-0033	4
5.2. Using with other boards	5
Appendix 1 Parts List	
Appendix 2 Circuit Diagram	

The product composition is shown below. Please check that all the following products are present before use.

Model Name	Contents	Quantity
M3A-0039	M66596FP Utility Board	1
RJJ11F0005	M3A-0039 Instruction Manual (Japanese)	1
REJ11F0004	M3A-0039 Instruction Manual (English)	1

This product is thus complied with European RoHS Directive.

The restriction of the use of certain Hazardous Substances in electrical and electronic equipment.

M66596FP comes with “USB Sample Firmware” for M66596FP evaluation.

For the details, please contact Renesas Technology or your distributor or check information on the following homepages.

Renesas Technology Homepage:

<http://www.renesas.com/>

For Renesas production support, contact to Customer Support Center:

csc@renesas.com

Inquiry about This Product

Please contact your distributor for technical support or Renesas production support for your technical inquiry via email.

Note: Please enter product number, your facsimile number, your phone number, your name, department, and organization in your inquiry email.

1. Summary

M3A-0039 is an evaluation board for Renesas original Hi-Speed USB ASSP M66596FP.

A USB-A receptacle is mounted on the board for evaluation of USB host operation using M66596.

Please refer to a data sheet “USB2.0 Dual Function Controller M66596FP/WG” about detailed specification of M66596.

The model name, package and package description of the chip that is mounted on the board is following.

Board	Chip Model Name	Package Model	Package Description
M3A-0039	M66596FP	64P6X	Plastic 64pin 10×10mm body LQFP

The board has the following features:

- (1) By connecting this board to a control board using the interface connector, it is possible to do evaluation on the user system.
- (2) A solder pattern (symbol name L2) is prepared on the USB signal line for chip common mode choke coil (Murata Manufacturing Co., Ltd. made), it is possible to do EMI suppression evaluation.
- (3) A solder pattern (symbol name U2) is prepared on the USB signal line for ESD protection device (Renesas Technology Corporation made), it is possible to do ESD protection evaluation.
- (4) It is possible to supply 1.5V to core power of M66596FP, and 3.3V or 1.8V to interface power VIF of M66596FP.
- (5) It is possible to select separate bus mode or multiplex bus mode for M66596FP.
- (6) It is possible to test M66596FP's functions (excluding split bus) by connecting with M3A-0033 board.
Note: M3A-0033 board is an evaluation board for Renesas original USB ASSP M66291.
- (7) It is possible to supply 5V, 500mA to VBUS.

2. Outline



Figure 1. M3A-0039 Board Top View

3. Specification

Board Size 70 mm × 80 mm

Supply power VDD: 1.5V
AFEA33V, AFED33V 3.3V
VIF: 3.3V or 1.8V

Interface: 50-pin Connector × 2 (2.54 mm pitch, dual straight header, male type)
USB Receptacle (Type A, DIP, normal) × 1

3.1 Connector Description

Connectors CN2 and CN3 provide all bus interface pins of the chip such as processor bus interface and DMA interface. Therefore, these pins provide the same pin characteristics of M66596FP such as electric characteristic, I/O direction, and functions except for the signal with *. The following tables show the pin number and function correspondences.

Pin Description of M66596FP	Connector	Pin Number of Connector	Function of M66596FP
D15-8	CN2	2-9(D15-8)	Data bus (I/O)
D6/AD6-D1/AD1	CN2	12-17(D6/AD6-D1/AD1)	Multiplex bus (I/O)
D7, D0	CN2	11, 18	Data bus (I/O)
SD7-0	CN2	41-48(SD7-0)	Split bus (DMA Interface) (I/O)
A5-1	CN3	16-12	Address bus (I)
A6/ALE	CN3	17(to connect ALE to CN3-21, please refer chapter 4 JP7)	Address bus or ALE for multiplex bus mode (I/O)
WR0_N*	CN3	1	Write strobe (I)
WR1_N*	CN2	23	Write strobe (I)
RD_N*	CN3	3	Read strobe (I)
CS_N*	CN3	5	Chip select (I)
RST_N***	CN3	6	Reset (I)
Vbus	CN2	24	Vbus (O)
EXIOVcc (VIF)	CN2	25, 26	Interface power supply (I)
DREQ0_N, DREQ1_N	CN3	7, 26	DMA request (O)
DACK0_N **	CN3	8	DMA Acknowledge (I)
DACK1_N/DSTB0_N **	CN3	25, 35	DMA Acknowledge (I) / Data strobe for DREQ0_N (I)
INT_N	CN3	9	Interrupt request (O)
VDD (EX_VCC)	CN3	19, 20	Power supply (3.3V) (I)
GND	CN2	1, 10, 19, 20, 29, 30, 49, 50	GND
GND	CN3	2, 4, 10, 11, 18, 29, 30, 49, 50	GND
SOF_N	CN3	24	SOF pulse (O)
DEND0_N, DEND1_N	CN3	36, 40	End of DMA transfer (I/O)
NC	CN2	21, 22	No pin
NC	CN2	31-40	Unused pin
NC	CN3	22,27,28,32-34,37-39,41-48	Unused pin
ID****	CN3	23	ID (O)
VBUS_EN****	CN2	27	VBUS supply IC Control (I)
FLAG****	CN2	28	VBUS over current detect (O)

*: Pulled up with 10kΩ

**: Pulled up with 1MΩ

***: Connected to GND with 0.1 μF

****: Signals of a USB VBUS power supply control IC

4. Jumper and Switch Setting

JP Number	Function	Factory Settings
JP1	It is necessary to short JP1 when supplying 3.3V from CN4.	Open
JP2	It is necessary to cut JP2's pattern when supplying 3.3 V from CN4.	Shorted
JP3	JP3 connects AGND and DGND outside M66596FP.	Shorted
JP5	It is necessary to cut JP5's pattern when dividing frame ground and signal ground.	Shorted

JP Number	Position	Function
JP4 (VIF)	"EXIOVcc"	Power is Supplied to VIF through CN2-25 and 26.
	"3.3V"	AFEA33V, AFED33V of M66596 and VIF are supplied from same source.

JP Number	Position	Function	Factory Settings
JP6 (VDD 1.5V)	"EXT"	CN3-31 are connected VDD of M66596.	"INT" (Shorted by pattern)
	"INT"	1.5V output of a regulator on the board is supplied to VDD of M66596.	

JP Number	Position	Function	Factory Settings
JP7	"ALE"	CN3-21 is connected ALE of M66596.	"A6/ALE" (Shorted by pattern)
	"A6/ALE"	CN3-17 are connected ALE of M66596.	

JP Number	Function		Factory Settings
	JP8 Short	JP9 Short	
JP8,JP9	CN3-25 is connected #61pin of M66596.	CN3-35 is connected #61pin of M66596.	Both JP8 and J9 are Shorted on the back surface of the board.

JP Number	Position	Function
JP10	VBUS_EN	USB VBUS power supply IC(U4) is controlled through CN2-27 .When the M3A-0039 is connected with M3A-0033, CN2-27 is connected to P106 of MCU on M3A-0033 via JP14 of M3-0033.
	VBUS_SW	USB VBUS power supply IC is controlled through SW2
	VBUS_ID	USB VBUS power supply IC is controlled through test pin ID.

SW Number	Function	
SW1 (MPBUS)	Switch to "SEPA"	Separate bus mode is selected.
	Switch to "MULT"	Multiplex bus mode is selected.

SW Number	Function	
	ON	OFF
SW2 (VUBS_SW)	When 5V is impressed to CN6 and JP10 is set to VBUS_SW side, 5V is supplied to VBUS of CN1.	Even though 5V is impressed to CN6 and JP10 is set to VBUS_SW side, 5V is not supply to VBUS of CN1.

5. Setup

The board combined with this board (M3A-0039) is called a target board in description below. This section illustrates how to use this board with a target board to connect to a USB device.

5.1 Using with M3A-0033

M3A-0033 is a motherboard for Renesas original USB ASSP. It is possible to test M66596FP easily by combining with this board and M3A-0033. But, it isn't possible to test M66596FP's split bus.

How to use M3A-0039 with M3A-0033 is shown as below.

- (1) Setting of switch and jumper
 - (a) Set SW1 to "SEPA". ("SEPA" is factory setting)
 - (b) Set JP4 to "3.3 V". ("3.3V" is factory setting)
 - (c) Set JP10 to "VBUS_SW", and turn on SW2 "ON". Current that is applied from CN6 goes through to VBUS by this setting.

 - (2) Connecting M3A-0039 to M3A-0033

Insert CN2's #1-pin and #2-pin of M3A-0039 board to CN8's #1-pin and #2-pin of M3A-0033 to connect two boards together.

 - (3) Power supply
 - (a) Apply power (DC5V) to CN6 of M3A-0039 board using an attached power supply cable. A red wire is 5V and a black one is GND.
 - (b) Apply power (DC5V) to CN1 of M3A-0033 board
 - (c) Insert the A-plug of a USB cable into CN1 of M3A-0039 and then insert the B-plug of the cable into an USB device.
- In order to control VBUS by MCU of M3A-0033, set jumper switches as below.
- (a) Set JP10 to "VBUS_EN".
 - (b) Short JP14 of M3A-0033
 - (c) When software carry out low level output from P106-port of the MCU, current that is applied from CN6 goes through to VBUS by this setting. When software carry out high level output P106-port, VBUS is turned off.

It is possible to operation of M66596FP using the remote debugger KD308 that is included with M3A-0033. Please refer to M3A-0033 Instruction Manual.

5.2 Using with other boards

M66596FP corresponds to a separate bus mode and multiplex bus mode. Switching SW1 of M3A-0039 according to the MCU to use. Below are notes for target board design.

5.2.1 Notes for target board design

- (1) The receptacle of a target board should suit the size of this board (Refer to Figure 3 and Figure 4). Please make pin arrangement same as this board (Refer to Table 1 and Table 2). Please refer to the M3A-0039 part list and circuit diagram when selecting connector and pin arrangement.
- (2) As incorrect insertion preventive measures, please carry out stuffing the pins of target board that correspond to #21-pin and #22-pin of CN2 of this board. When HKP-50FD2 of Honda Communication Industry is used as receptacle, GM-25K of this company suit as stuffing.
- (3) The core power supply of M66596FP is 1.5V. A regulator makes 1.5V from 3.3V through #19-pin and #20-pin of CN3.
- (4) The interface power supply VIF is 1.8V (1.6-2.0V) or 3.3V (2.7-3.6V). Short JP4 to “EXIOVcc” and supply interface power by #25-pin and #26-pin of CN2. Please short JP4 to “3.3V”, when VIF is 3.3V. In this case, supply interface power voltage is same as AFEA33V, AFED33V.
- (5) Please use SD0-SD7 of CN2 when using split bus for DMA.
- (6) Processing for for unused pin : Please refer to the M66596 datasheet, USB2.0 Dual Function Controller M66596FP/WG, for details.

5.2.2 VBUS control circuit

Note: When a USB device is in unusual state such as shorted or over current etc., there is a possibility of causing destruction of the USB VBUS power supply IC by heat load.

Please confirm that the USB device is in usual state, before connection.

➤ There are three ways to VBUS output . Supply 5V to CN6.

(a) Case of using VBUS_EN

Set JP10 to “VBUS_EN”, and set VBUS_EN of CN2’s #27 pin low. Then current that is applied from CN6 goes through to VBUS.

When over current is carried out, FLAG signal (CN2’s #28 pin) goes low.

It is necessary a protection circuit to prevent over absolute maximum rating of the USB VBUS power supply IC. Please refer to the appendix 1, part list, for part number of the USB VBUS power supply IC.

(b) Case of using VBUS_SW

Set JP10 to “VBUS_SW”, and set SW2 to ON. Then current that is applied from CN6 goes through to VBUS.

(c) Case of using test pin ID

A test pin ID is prepared on M3A-0039. Set JP10 to “VBUS_ID”, and set test pin ID to low. Then current that is applied from CN6 goes through to VBUS. When the test pin ID is set to high, VBUS output is turned off.

5.2.3 Separate bus mode

Please switch SW1 of M3A-0039 board to “SEPA” when using as separate bus mode. Use A1-A6 of CN3 as address bus.

5.2.4 Multiplex bus mode

Please switch SW1 of M3A-0039 board to “MULT” when using as multiplex bus mode. Use AD1-AD6 of CN3 as address line share with data line. Keep open A1-A5 of CN3. Use 17-pin (A6/ALE) of CN3 as ALE.

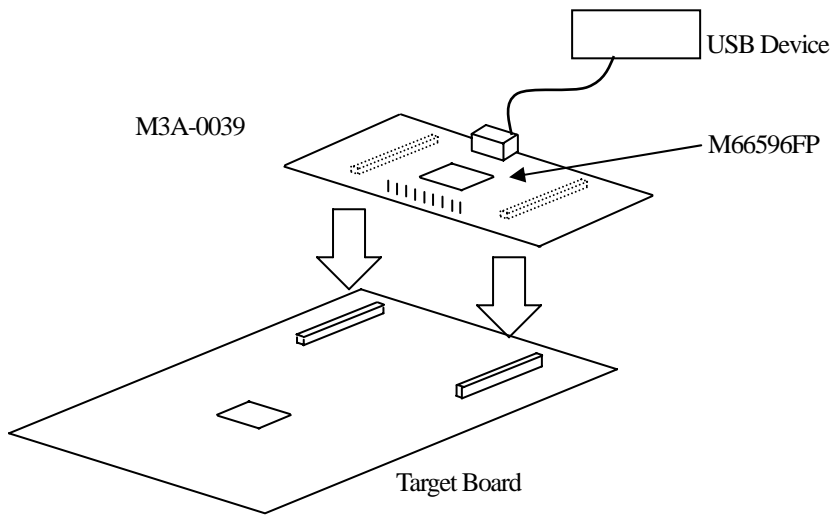

Figure 2. Target Board Connection Illustrator

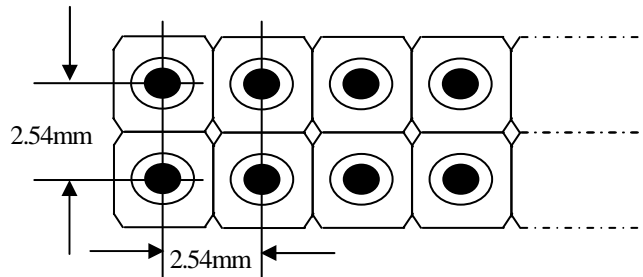

Figure 3. Pin Pitch of Connectors CN2 and CN3

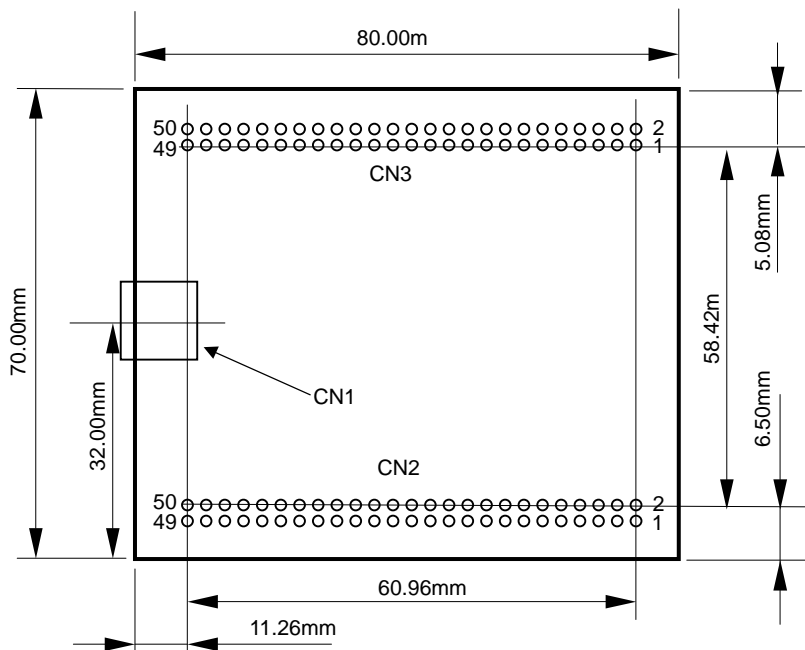

Figure 4. Pin Direction of Connector CN2 and CN3 (Top View)

Table 1. M3A-0039 CN2 Pin Assignment

PIN	16bit-sepa *1	16bit-multi *2	PIN	16bit-sepa *1	16bit-multi *2
1	GND	GND	2	D15	D15
3	D14	D14	4	D13	D13
5	D12	D12	6	D11	D11
7	D10	D10	8	D9	D9
9	D8	D8	10	GND	GND
11	D7	D7	12	D6	D6/AD6
13	D5	D5/AD5	14	D4	D4/AD4
15	D3	D3/AD3	16	D2	D2/AD2
17	D1	D1/AD1	18	D0	D0
19	GND	GND	20	GND	GND
21	No Available	No Available	22	No Available	No Available
23	WR1_N	WR1_N	24	VBUS	VBUS
25	EXIOVcc	EXIOVcc	26	EXIOVcc	EXIOVcc
27	VBUS_EN	VBUS_EN	28	FLAG	FLAG
29	GND	GND	30	GND	GND
31			32		
33			34		
35			36		
37			38		
39			40		
41	SD7	SD7	42	SD6	SD6
43	SD5	SD5	44	SD4	SD4
45	SD3	SD3	46	SD2	SD2
47	SD1	SD1	48	SD0	SD0
49	GND	GND	50	GND	GND

Table 1. M3A-0039 CN3 Pin Assignment

PIN	16bit-sepa *1	16bit-multi *2	PIN	16bit-sepa *1	16bit-multi *2
1	WR0_N	WR0_N	2	GND	GND
3	RD_N	RD_N	4	GND	GND
5	CS_N	CS_N	6	RST_N	RST_N
7	DREQ0_N	DREQ0_N	8	DACK0_N	DACK0_N
9	INT_N	INT_N	10	GND	GND
11	GND	GND	12	A1	Unused
13	A2	Unused	14	A3	Unused
15	A4	Unused	16	A5	Unused
17	A6	ALE	18	GND	GND
19	EXVcc	EXVcc	20	EXVcc	EXVcc
21	Unused	(JP7-ALE)	22		
23	ID	ID	24	SOF_N	SOF_N
25	DACK1_N/DSTB0_N	DACK1_N/DSTB0_N	26	DREQ1_N	DREQ1_N
27			28		
29	GND	GND	30	GND	GND
31	JP6-EXT(External 1.5V Input)	JP6-EXT(External 1.5V Input)	32		
33			34		
35	DACK1_N/DSTB0_N	DACK1_N/DSTB0_N	36	DEND0_N	DEND0_N
37			38		
39			40	DEND1_N	DEND1_N
41			42		
43			44		
45			46		
47			48		
49	GND	GND	50	GND	GND

*1: When select 16bit-Separate Bus mode

*2: When select 16bit-Multiplex Bus mode

Appendix1: Part List

Renesas Solutions Corporation

Drawing No.		PPL-M3A-0039		Title	M3A-0039 Rev.A	
No.	Component Name		Component Specification		Notes	
	Type	Symbol on Board	Product Number	Manufacture		
1	USB SOCKET	CN1	UBA-R4R-D10-1(LF)(SN)	JST		
2	HEADER 25X2	CN2, CN3	FFC-50BSM1B	Honda		
3	HEADER	CN4	BS2P-SHF-1AA(LF)(SN)	JST	No mounted.	
4	HEADER	CN6	BS2P-SHF-1AA(LF)(SN)	JST		
5	Ceramic Capacitor	C1, C2, C3, C15, C29	GRM31CB11A106KA01	Murata	10uF	
6	Chip Capacitor	C4, C6, C8, C13, C16, C34	GRM188F11E104ZA01D	Murata	0.1uF	
7	Chip Capacitor	C5, C7, C9, C17	GRM2162C1H100JZ01D	Murata	10pF	
8	Chip Capacitor	C30, C33	GRM219F11E105ZA01D	Murata	1.0uF	
9	Chip Capacitor	C18, C19	GRM1882C1H8R0DZ01D	Murata	8pF	
10	Chip Capacitor	C14, C20-28, C32	GRM188F11H103ZA01D	Murata	0.01uF	
11	Chip Capacitor	C31	F931A157MNC	Nichikon	150uF	
12	Jumper SW (2pin)	JP1, JP2, JP3, JP5, JP8, JP9	WL-1	MAC8	No mounted.	
13	Jumper SW (3pin)	JP4	WL-1	MAC8		
14	Jumper SW (4pin)	JP10	WL-1	MAC8		
15	Chip Ferrite Bead	L1, L3	BLM21PG600SN1	Murata	No mounted.	
16	Common Mode Choke Coil	L2	DLW21HN900SQ2	Murata	No mounted.	
17	Chip Resistor	R1, R2, R3, R16, R17	MCR10EZPJ000	Rohm	0Ω.	
18	Chip Resistor	R4, R5, R11	MCR10EZPJ105	Rohm	1M, 5%	
19	Chip Resistor	R6-9, R13-15, R18	MCR10EZPJ103	Rohm	10kΩ, 5%	
20	Chip Resistor	R10	MCR10EZPF5601	Rohm	5.6kΩ, 1%	
21	Chip Resistor	R12	MCR10EZPF5600	Rohm	560Ω, 1%	
22	Chip Resistor	R21	MCR10EZPJ102	Rohm	1kΩ, 5%	

No.	Component Name		Component Specification		Notes
	Type	Symbol on Board	Product Number	Manufacture	
23	Chip Resistor	R23	MCR10EZPJ101	Rohm	100Ω, 5%
24	Slide SW	SW1, SW2	CAS-120A1	Copal	
25	ASSP	U1	M66596FP	Renesas	
26	Zener Diode	U2	RKZ6.2Z4MFAKT	RENESAS	No Mounted.
27	1.5V VDD	U3	LP2992AIM5-1.5/NO PB	NS	1.5V 250mA
28	USB power supply switch	U4	MIC2025-2YM	MICREL	
29	Crystal Oscillator	X1	DSX321G 24.0000MHz	Daishinku	
30	Test Pin (SMD)	TP1 (AFE33V)	HK-5-G (Purple)	Mac8	
31	Test Pin (SMD)	TP2 (AFED33V)	HK-5-G (Red)	Mac8	
32	Test Pin (SMD)	TP3 (VDD)	HK-5-G (Orange)	Mac8	
33	Test Pin (SMD)	TP4, TP5, TP6, TP7, TP8 (G ND)	HK-5-G (Black)	Mac8	
34	Test Pin (SMD)	TP9 (Vbus)	HK-5-G (Blue)	Mac8	
35	Test Pin (SMD)	TP10 (VIF)	HK-5-G (Green)	Mac8	
36	Test Pin (SMD)	TP14 (ID)	HK-5-G (Gray)	Mac8	
37	Test Pin (SMD)	TP15 (VBUS_SEL)	HK-5-G (Brown)	Mac8	
38	Test Pin (SMD)	TP16 (FLAG)	HK-5-G (White)	Mac8	
39	Jumper Socket	For JP4, JP10	JS-1	Mac8	

Appendix2 : Circuit Diagram

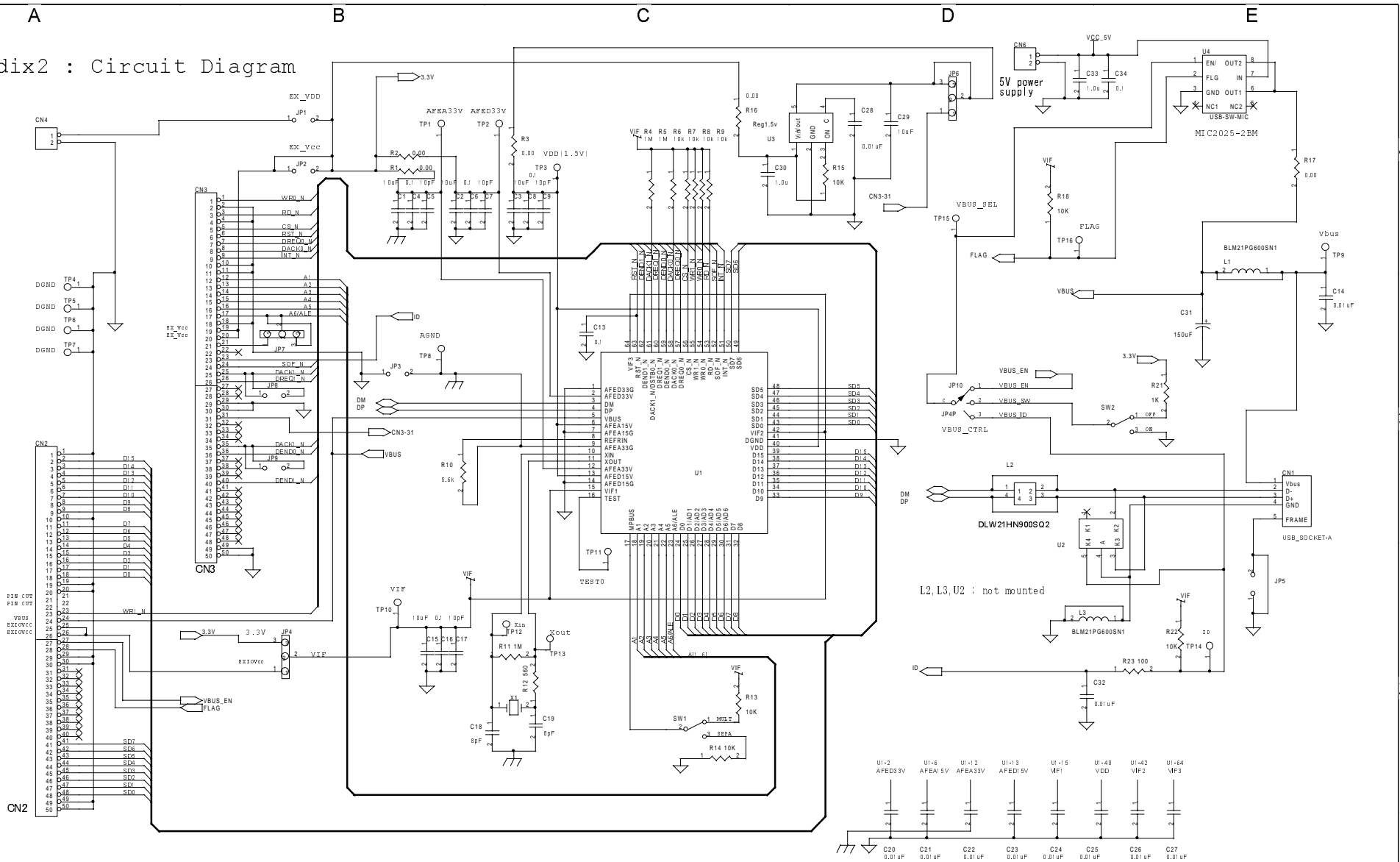

M3A-0039

Revision History	M3A-0039 Instruction Manual
-------------------------	------------------------------------

Rev.	Date	Description	
		Page	Summary
1.00	Dec.01.04	—	First edition issued
1.01	Dec.06.06	Contents	Addition: This product is thus complied with European RoHS Directive.
		Appendix 1	Parts List Modified : # 1,3,4,5,6,7,8,9,10,17,18,19,20,21,22,23,26,27,28 (Part type name is thus complied with European RoHS Directive)