

# RL78/I1A Group

R01QS0023EU0100

Rev.1.00

## LED Lighting AC/DC Converter Quick Start Guide

Apr 30, 2018

### Introduction

This quick start guide describes the Renesas Lighting Solution Demo setup. Highlighted components in this solution includes TPW-RL78I1A-1C, TPW-RL78I1A-2C and TCM-RL78I1A demo kits which are using Renesas RL78/I1A Microcontroller Group for Lighting power control to LED modules as well as Digital Addressable Lighting Interface (DALI) communication. Using these Renesas Lighting Solution Demos, developers can easily start to evaluate on Renesas lighting solution. Contact your nearest Renesas sale offices to request a live demonstration or kit for development.

### Target Device

R5F107DE and R5F1076C

### Contents



<b>Safety Precautions .....</b>	<b>2</b>
<b>1. Demo Package.....</b>	<b>5</b>
1.1 Demo Case.....	5
1.2 Package Contents .....	6
<b>2. Features .....</b>	<b>7</b>
2.1 TPW-RL78I1A-1C AC/DC 1-Converter Demo .....	7
2.2 TPW-RL78I1A-2C AC/DC 2-Converter Demo .....	8
2.3 TCM-RL78I1A Lighting Communication Master Board .....	9
<b>3. Demo Operation .....</b>	<b>10</b>
3.1 TPW-RL78I1A-1C AC/DC 1-Converter Demo .....	10
3.2 TPW-RL78I1A-2C AC/DC 2-Converter Demo .....	12
<b>4. Changing Demo Firmware .....</b>	<b>15</b>
4.1 Programming to the TPW-RL78I1A-1C AC/DC 1-Converter Unit.....	15
4.2 Programming to the TPW-RL78I1A-2C AC/DC 2-Converter Unit.....	17
<b>Appendix .....</b>	<b>19</b>
<b>Reference .....</b>	<b>21</b>

## Safety Precautions







This document describes items to be observed to ensure the safe use of this evaluation board. **Be sure to read this document before using the board.**

### Symbols Used



This document uses the following symbols for items to be observed to ensure the safe use of the unit. The symbols are followed by a brief explanation of the possible extent of problems which may occur if the items are not observed.

	<b>Danger</b>	The risk is high if the warning is not observed, and the user may suffer death or serious injury.
	<b>Warning</b>	The user may suffer death or serious injury if the warning is not observed.
	<b>Caution</b>	Human injury or property damage may occur if the caution is not observed.

The following symbols express behaviors that are prohibited in order to prevent injury or accident.

	<b>General prohibition</b> The action mentioned is prohibited.		<b>Do not touch</b> Touching the specified location may cause injury.		<b>Do not disassemble</b> Disassembly may cause a problem such as electric shock or product failure.
	<b>Keep away from water</b> Use near water poses the risk of electric shock or product failure if moisture were to contact the unit.		<b>Flammable</b> Proximity to flame may cause the unit to catch fire.		<b>Do not touch with wet hands</b> Touching with wet hands may cause electric shock or product failure.











The following symbols are used for cautions to prevent product failure and accidents.

	<b>General caution</b> Unspecified general cautions		<b>Caution: Hot</b> Human injury due to a high temperature
---	--	---	---



The following symbols are used for instructions to prevent product failure and accidents.

	Action required of the user		Instruction to unplug from AC power supply
---	-----------------------------	---	--

## Warning displays for this product

 <b>Danger</b>	
	If this product is used in a way that is prohibited or not specified in this user's manual, the safety of the product may not be guaranteed. Read the user's manual thoroughly before using this product
	<b>Do not touch with wet hands.</b> This may cause electric shock or failure.
	<b>Do not use or store this product in any of the following locations.</b> - Environments with excessive water, humidity, steam, dust, fumes, etc. - Environments where static electricity or electrical noise is readily generated. The above can lead to electric shock or product failure.
	<b>Do not allow unqualified people to use this product.</b> Wear protective gloves to prevent electric shock.
 <b>Warning</b>	
	<b>Do not disassemble or modify the product.</b> Doing so may cause the product to fail, emit smoke, catch fire, or result in electric shock.
	<b>Do not heat the product or expose it to fire and do not short the terminals.</b> Doing so may cause the product to fail, heat up, catch fire, or rupture.
	<b>Do not drop the board or subject the board to heavy impact.</b> Doing so may break or damage the board, causing fire or electric shock.
	<b>Use an input voltage from 100 VAC to 240 VAC.</b> Application of an input outside this range may cause failure, overheating, fire, or electric shock.
	<b>Do not insert or remove a connector or cable when the power of this product is on.</b> Inserting or removing a connector or cable when the power is on may cause failure, overheating, fire, or rupture.
	<b>Do not turn on the power if the AC power, LED connection cables, and interface cables are not connected properly.</b> Incorrect connections may cause failure, overheating, fire, or electric shock.
	<b>When transporting or moving this product, remove the power cord and other cables.</b> Otherwise, the cables may be damaged, resulting in failure, overheating, fire, or electric shock.
	<b>Do not use power cords other those supplied.</b> Using a non-conforming power cord may cause failure, overheating, fire, or electric shock.
	<b>When using the product, check that there is an accessible power outlet within reach of the product.</b>
	<b>If smoke or an abnormal smell or sound is emitted or if overheating occurs, promptly unplug the AC power supply.</b> Using the product in such a state poses a risk of fire, burning or electric shock.

## Caution displays for this product

 <b>Caution</b>	
	To prevent destruction due to static electricity, be careful of electrostatic charge when touching metal parts such as a connector. Electrostatic charge can cause product failure.
	This product is for indoor use only.

## 1. Demo Package

### 1.1 Demo Case

The Lighting demo is packaged in Pelican Case and it contains a set of demonstrations as below.

1. AC/DC 1-Converter Demo which uses TPW-RL78I1A-1C unit
2. AC/DC 2-Converter Demo which uses TPW-RL78I1A-2C unit and TCM-RL78I1A Lighting Communication Master Board



1.2 Package Contents

<i>Components</i>	<i>Pictures</i>
TPW-RL78I1A-1C AC/DC 1-Converter LED Power Supply Evaluation Unit	
TPW-RL78I1A-2C AC/DC 2-Converter LED Power Supply Evaluation Unit	
RTK0EB0006D00002BJ Lighting communication master board	
JDHT8R-A0230-8080-T00-NSA LED Module 8" 7950LM 3000K 80CRI (White)	
Accessories (1 Power Supply Cable, 1 USB Mini-B cable and 1 Push Pin)	
	
	

## 2. Features

### 2.1 TPW-RL78I1A-1C AC/DC 1-Converter Demo

The default demonstration for this unit is Analog input dimming mode. However, various types of dimming operations can be performed by using the Applilet EZ for HCD tool <sup>1</sup> and detail are its user manual <sup>2</sup> (R20UT0435EJ1300). This demo supports five dimming modes as follow:

- Fix dimming mode
- Variable dimming mode
- Analog input dimming mode (default)
- Switch dimming mode
- Serial command dimming mode

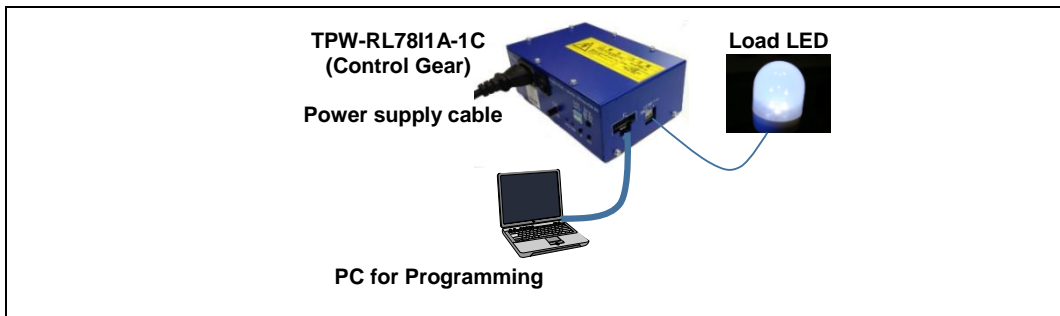

The demo unit comes with three operation modes: Normal Operation mode, OCD/Flash mode, and Virtual UART mode. You can select respective operation by Configuration Switch and Debug Switch setting as below.

Operation mode	Debug	Config. Switch			
		1	2	3	4
Normal operation mode	 Debug USB RUN OCD (E1) → (*)	OFF	OFF	OFF	OFF
OCD/Flash mode	 Debug USB RUN OCD (E1) ← (*)	OFF	ON	OFF	ON
Virtual UART mode	 Debug USB RUN OCD (E1) → (*)	ON	OFF	ON	OFF

\* The arrows indicate the operating direction of the switch.

### Electrical Specifications

Main unit: TPW-RL78I1A-1C unit (Control Gear)  
 Input voltage: 100 to 240 VAC (50/60 Hz)  
 Input voltage fluctuation: ±10%  
 Output: 60 VDC (max.), 200 mA (max.)  
 Operating ambient temperature: 0 °C to 45 °C

### TPW-RL78I1A-1C System Block Diagram

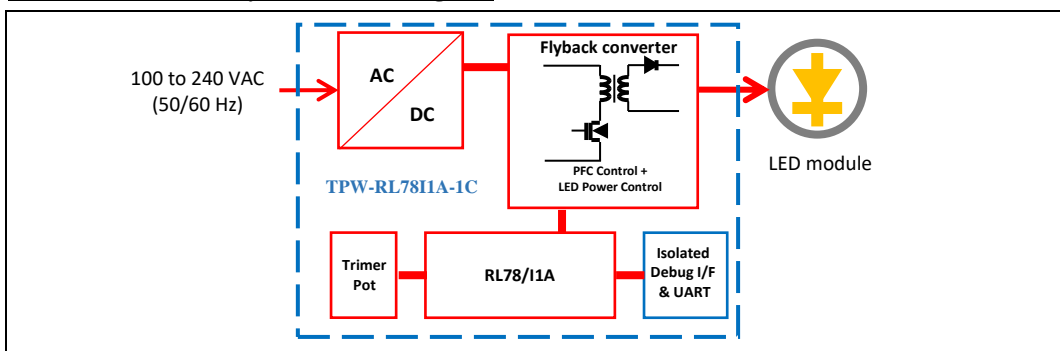



**2.2 TPW-RL78I1A-2C AC/DC 2-Converter Demo**

The default demonstration for this unit is DALI dimming mode. However, various types of dimming operations can be performed by programming the RL78/I1A. The Applilet EZ for HCD tool supports six dimming modes as follow:

- Fix dimming mode
- Variable dimming mode
- Switch dimming mode
- Serial command dimming mode
- Infrared dimming mode
- DALI dimming mode (default)

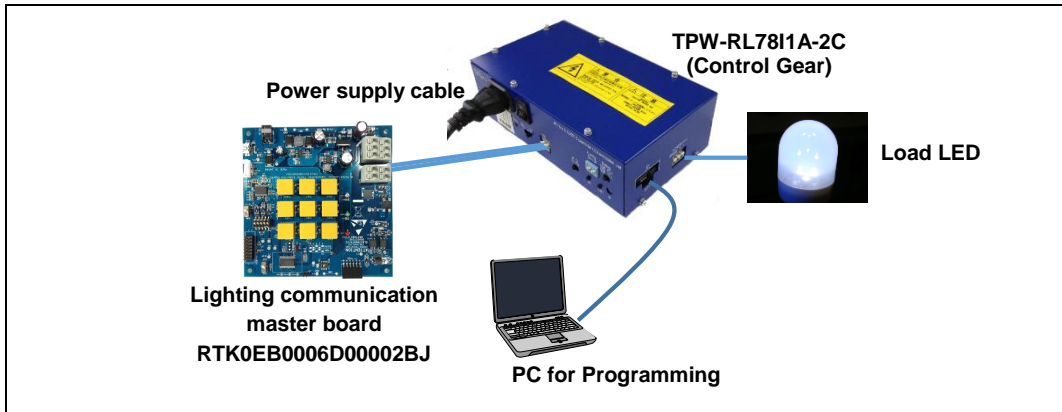

The demo unit offers three operation modes: Normal Operation mode, OCD/Flash mode, and Virtual UART mode. For operation, select one of the modes by using Configuration Switch and Debug Switch setting as below.

Operation mode	Debug	Config. Switch				DALI/OFF	IR CH
		1	2	3	4		
Normal operation mode	 → (*)	OFF	OFF	OFF	OFF		
OCD/Flash mode	 ← (*)	OFF	ON	OFF	ON	Don't Care	Don't Care
Virtual UART mode	 → (*)	ON	OFF	ON	OFF		

\* The arrows indicate the operating direction of the switch.

**Electrical Specification**

Main unit: TPW-RL78I1A-2C unit (Control Gear)  
 Input voltage: 100 to 240 VAC (50/60 Hz)  
 Input voltage fluctuation: ±10%  
 Output: 200 VDC (max.), 250 mA (max.)\*  
 Operating ambient temperature: 0 °C to 45 °C

\* Note: changing parameter in firmware can adjust the output voltage

**TPW-RL78I1A-2C System Block Diagram**

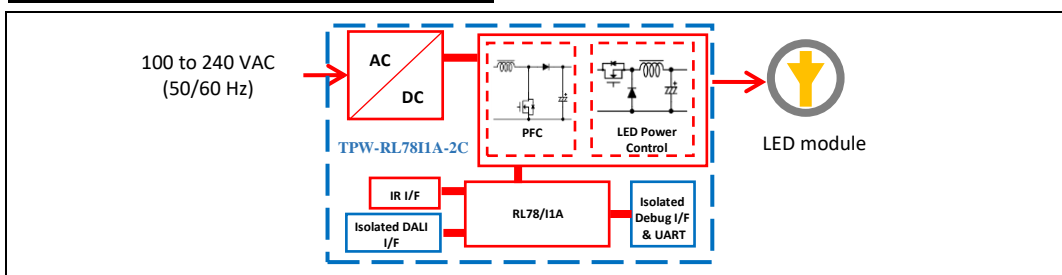



### 2.3 TCM-RL78I1A Lighting Communication Master Board

The Lighting Communication Master board can be used as master controller support three communication interface with different Lighting Evaluation boards.

- DALI protol communication interface
- DMX512 protol communication interface
- Infrared Remote Control interface
- PMOD #1 interface

By default, this unit supports DALI, DMX512 and IR communication for demonstration. It is necessary to reprogram by using the Applilet EZ for HCD tool only for altering the keypad function assignment from default value.

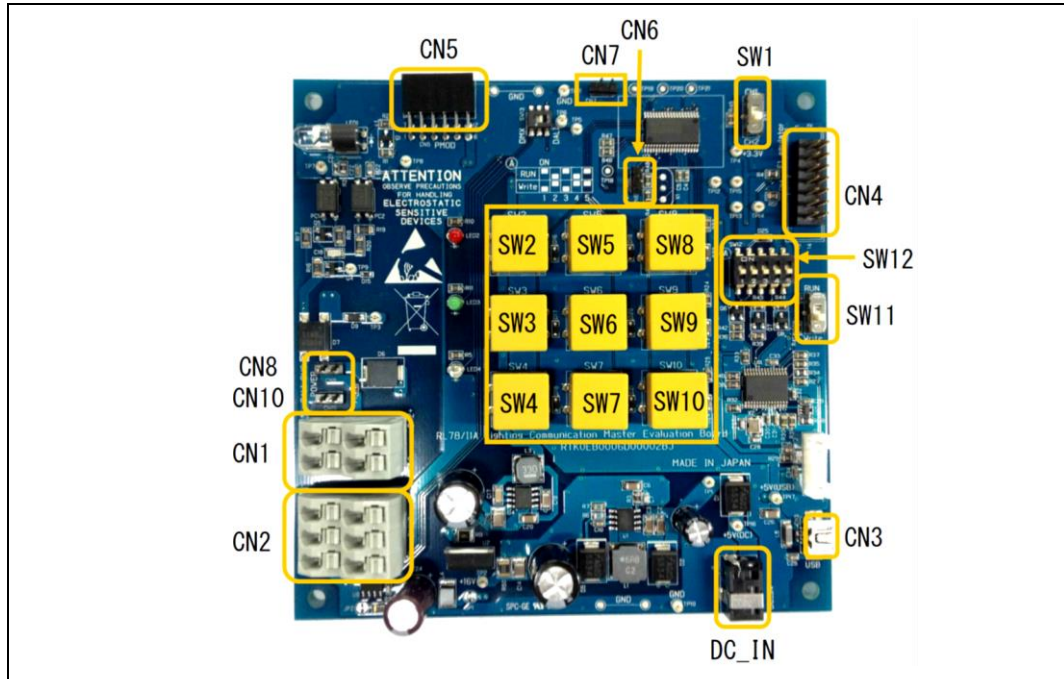

To evaluate the communication master board, use provided onboard connectors and switches for respective interface. Use SW11 and SW12 to set run mode for operation or set to write mode for reprogramming the board.

Part	Function
CN1	DALI protocol communication interface connector
CN2	DMX 512 protocol communication interface connector
CN3	USB interface connector
CN4	Connector for E1 emulator
CN5	PMOD communication connector
CN6	Power supply jumper to ADC potential reference (shared pin)
CN7	Power supply jumper to ADC potential reference (shared pin)
CN8	Power supply jumper to DALI bus
CN10	Power supply jumper to DALI bus
DC_IN	DC jack
SW1	Infrared setting for display side custom code CH 1 = 0x1234 CH 2 = 0x5678
SW2-SW9	DALI communication command transmission switch
SW10	Infrared communication command transmission switch
SW13	DALI communication / DMX 512 communication changeover switch DALI display side DALI communication use DMX 512 Display side DMX 512 communication use

Switch	set to	Mode	
		RUN	WRITE
SW12	1	ON	OFF
	2	OFF	ON
	3	ON	OFF
	4	OFF	ON
	5	ON	OFF

#### Detail Specification

Main unit: TCM-RL78I1A main unit  
 Supply Voltage: DC 5 volt ±10% (center positive for DC\_IN connector)  
 Microcontroller: RL78 / I1A (R5F107DEGSP)

Note 1: In case of using CN3 USB power source to DALI bus power supply (insert CN 8 and CN10), it may cause insufficient power depending on the current limit of the power source from personal computer (PC).

Note 2: In case of using external DALI power supply to DALI bus, remove CN 8 and CN10 jumpers.

### 3. Demo Operation

#### 3.1 TPW-RL78I1A-1C AC/DC 1-Converter Demo

As default, the RL78/I1A AC/DC 1 converter LED evaluation unit is programmed with Analog input dimming mode firmware. To demonstrate other than Analog input dimming mode demo, the unit is needed to reprogram appropriate firmware.

- Step 1.** Take out TPW-RL78I1A-1C (AC/DC 1-Converter) unit and LED module from Pelican Case.  
**CAUTION: Do not apply power to LED module when it is in Pelican Case.**
- Step 2.** Connect LED module to LED output connector, AC/DC 1-Converter unit by inserting LED module Red wire (labeled with +) to LED OUT (+) terminal and Black wire to LED OUT (-) terminal.

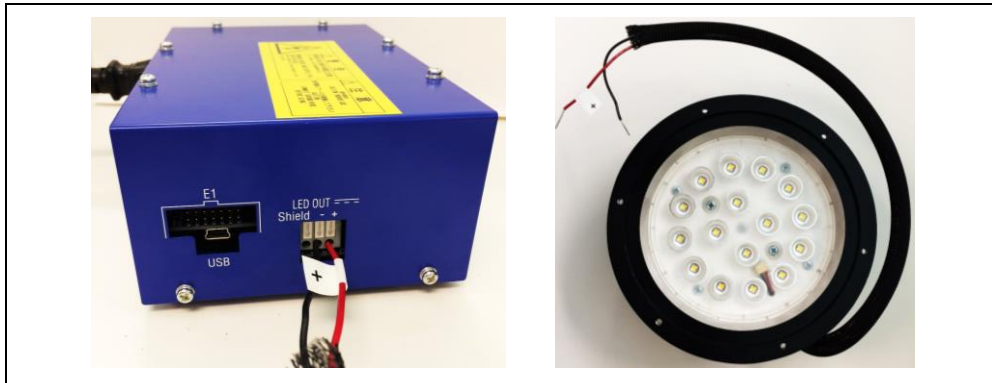

- Step 3.** Set “Normal operation mode”: Configuration Switch 1, 2, 3, and 4 to OFF position and Debug Switch to RUN position.



- Step 4.** Connect power cable to AC/DC 1-Converter unit and turn on the power by ON-OFF switch. Both RED LED (STATUS) and GREEN LED (POWER) are light on when the unit is on.



- Step 5.** Press SW switch to calibrate the newly attached LED module with AC/DC 1-Converter unit. If the LED module is within the limit of AC/DC 1-Converter unit, the RED LED will turn off. If not, it will blink to indicate the error. Press RESET switch to reset the AC/DC 1-Converter unit in case of error.

**Step 6.** The calibration sets LED module lighting intensity to minimum. To increase lighting intensity, turn the VOLUME knob to MAX position.



Below shows the working test setup of the AC/DC 1-Converter unit, which attached with LED module.



Note: Use push pin to detach the LED module from the AC/DC 1-Converter unit as shown below. Push respective terminal and pull the wire simultaneously to detach form the AC/DC 1-Converter unit.

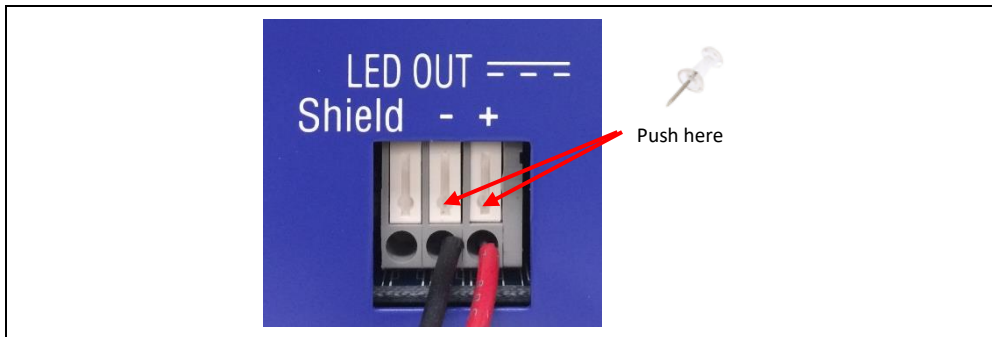

### 3.2 TPW-RL78I1A-2C AC/DC 2-Converter Demo

The RL78/I1A AC/DC 2 converter LED evaluation unit is programmed with DALI dimming mode firmware by default. If you want to evaluate other dimming mode demos, it is needed to reprogram with respective firmware.

#### (a) Hardware Setup

**Step 1.** Take out TPW-RL78I1A-2C (AC/DC 2-Converter) unit, TCM-RL78I1A unit and LED module from Pelican Case.

**CAUTION: Do not apply power to LED module when it is in Pelican Case.**

**Step 2.** Connect LED module to LED output connector, AC/DC 2-Converter unit by inserting LED module Red wire (labeled with +) to LED OUT (+) terminal and Black wire to LED OUT (-) terminal.

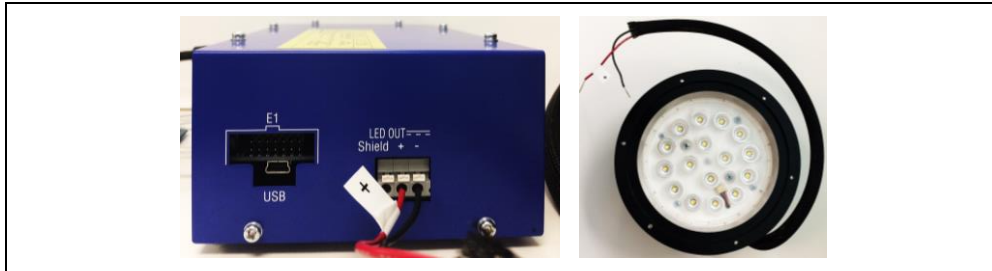

**Step 3.** Connect with two DALI cables (no polarity) between Lighting Communication Master board and AC/DC 2-Converter unit. Then connect PC to Lighting Communication Master board via USB cable.

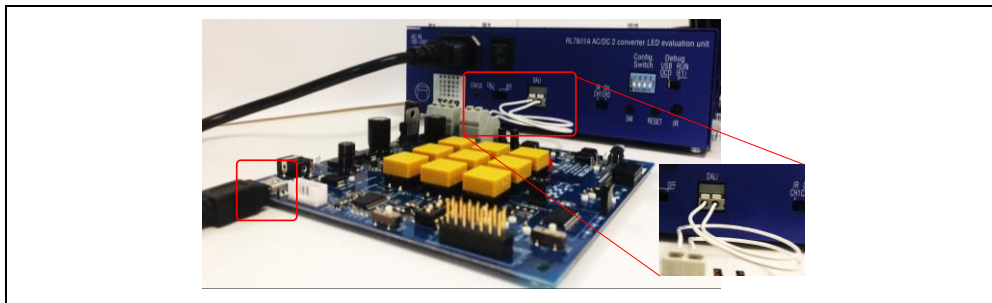

**Step 4.** Set “Normal operation mode” to AC/DC 2-Converter unit: Configuration Switch 1, 2, 3, and 4 to OFF position and Debug Switch to RUN position.



**Step 5.** Connect power cable to AC/DC 2-Converter unit and turn on the power by ON-OFF switch. RED LED (STATUS) is light on when the unit is on.



**Step 6.** Press SW switch to calibrate the newly attached LED module with AC/DC 2-Converter unit. If the LED module is within the limit of AC/DC 2-Converter unit, the RED LED will turn off. If not, it will blink to indicate the error. Press RESET switch to reset the AC/DC 2-Converter unit in case of error.



**(b) DALI Master Controller Setup and Operation**

Before starting Lighting Demo, it is needed to download the DALI Master Controller GUI application <sup>3</sup> (version 2.02 or later) from below link and install in PC. Detail are described in DALI Master Controller GUI User Manual <sup>4</sup> (R20UT0715EJ0300).

**DALI Master Controller GUI download link:** <https://www.renesas.com/en-us/software/D6000479.html>

**Step 1.** Open DALI Master Controller application from Windows Start menu or by clicking the icon.

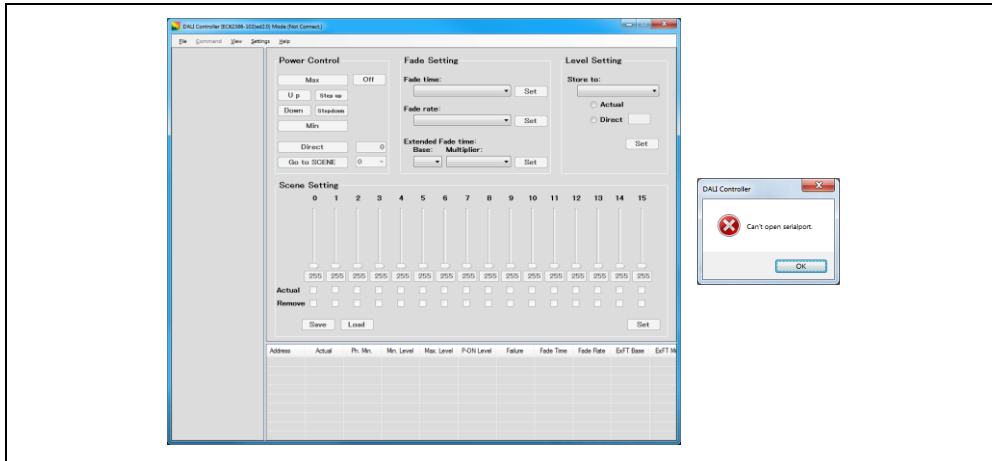

**Step 2.** If prompt “Can’t open serialport” message box, click “OK” button to close the message box.

**Step 3.** Select “Settings” from pulldown menu and “Serial” setting. Then, set appropriate COM port from “Serial” Combo box and click “OK” button.

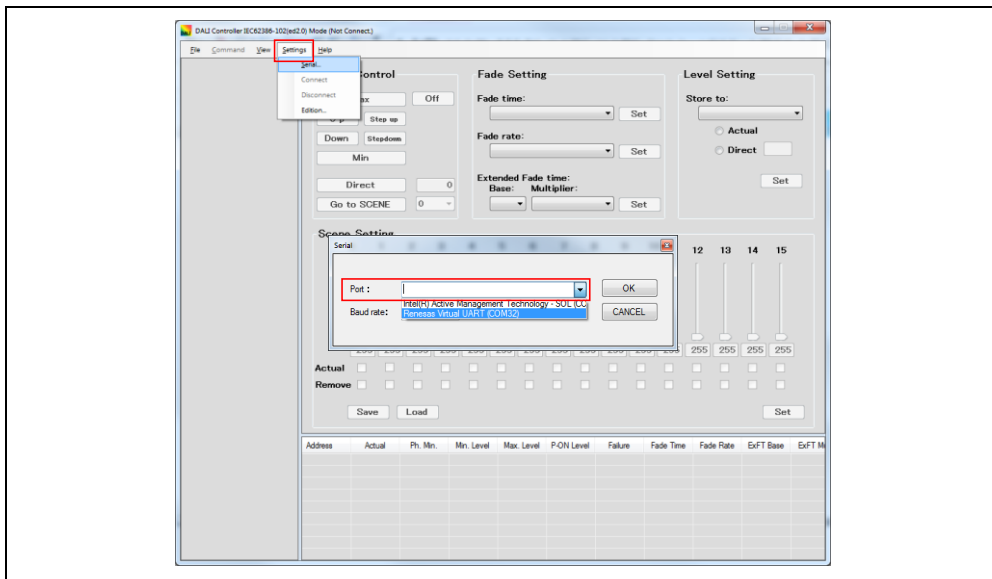

**Step 4.** By default, DALI Master Controller GUI application opens in IEC62386-102ed2.0 mode. If need to change the edition, select “Settings” from pulldown menu and “Edition” setting.

**Step 5.** Select desire edition from “Edition Select” message box and click “OK” button. To change the newly selected Edition, close the GUI application and reopen it again.

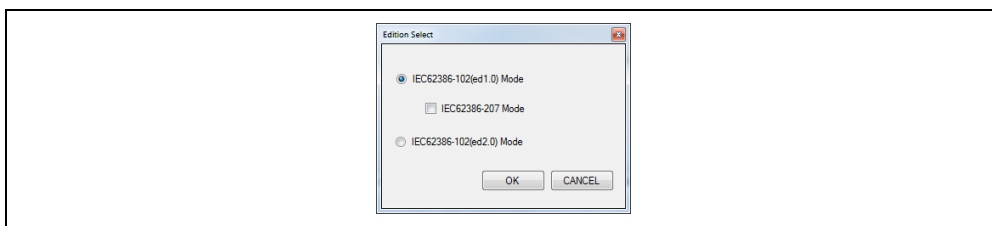

**Step 6.** Open Log Windows from View pulldown menu and select “Log” to check the activities between GUI and AC/DC 2-Converter unit.

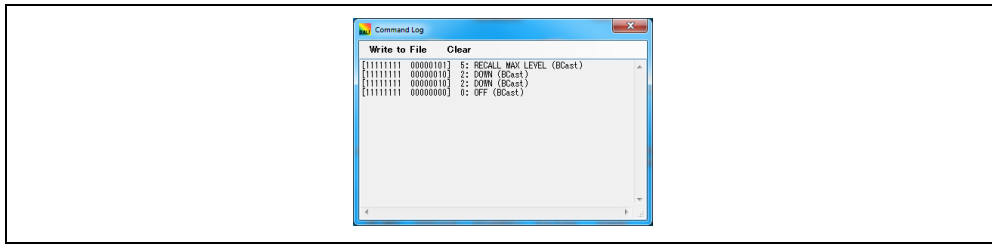

**Step 7.** To assign short address of the AC/DC 2-Converter unit, select “Command” form pulldown menu and “Random Address Allocation”. The “Random Address Allocation” dialog box will be opened.

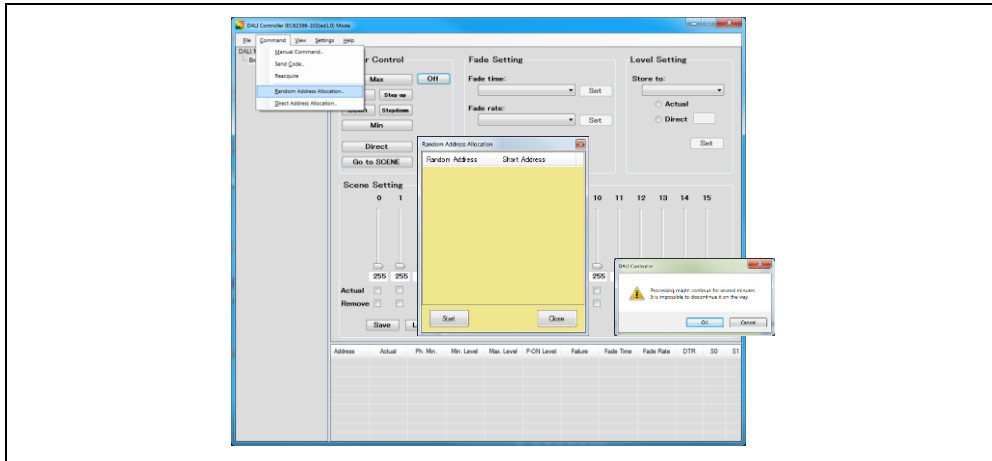

**Step 8.** Click “Start” button and prompt “DALI controller” message box. Click “OK” button and wait for completion of assigning the short address. Then click “Close” button after assigning the address.

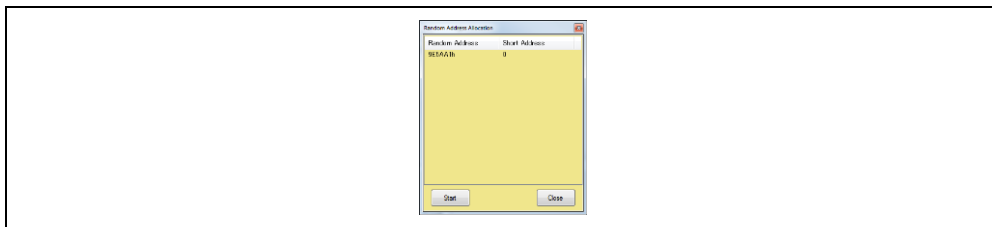

**Step 9.** Select one of the Addresses and set desire Fade Setting. Then, click Power Control buttons for controlling the LED lighting.

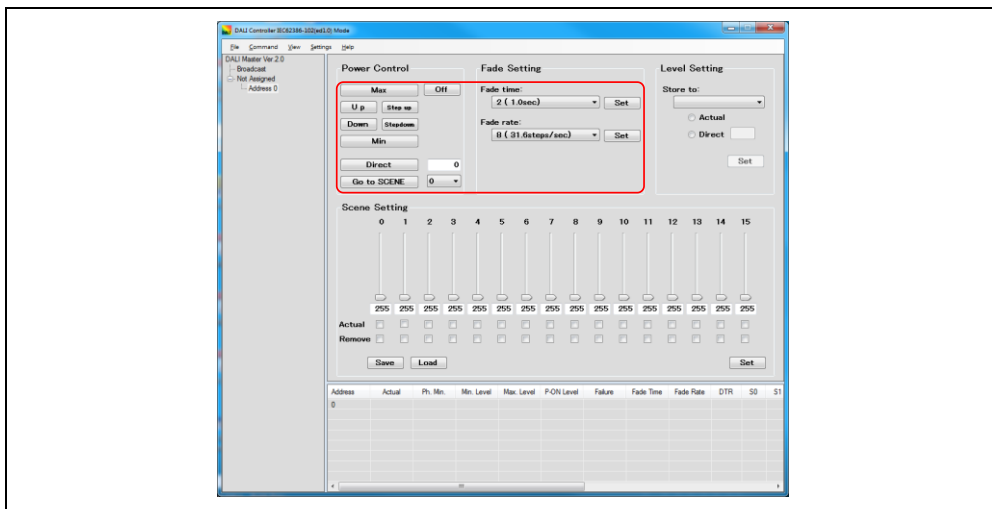

## 4. Changing Demo Firmware

For changing the firmware, use Renesas Flash Programmer GUI [5](#) with virtual UART mode. Before programming, download the Renesas Flash Programmer package (version 3.0 or later).

### 4.1 Programming to the TPW-RL78I1A-1C AC/DC 1-Converter Unit

- Step 1.** Connect between AC/DC 1-Converter unit and PC via mini USB cable.
- Step 2.** Set “OCD/Flash mode”: Configuration Switch 1 and 3 to OFF position, and 2 and 4 to ON position. Then set Debug Switch to USB (OCD) position.



- Step 3.** Open Renesas Flash Program, and create a new project using “Create New Project” selection from “File” pulldown menu.

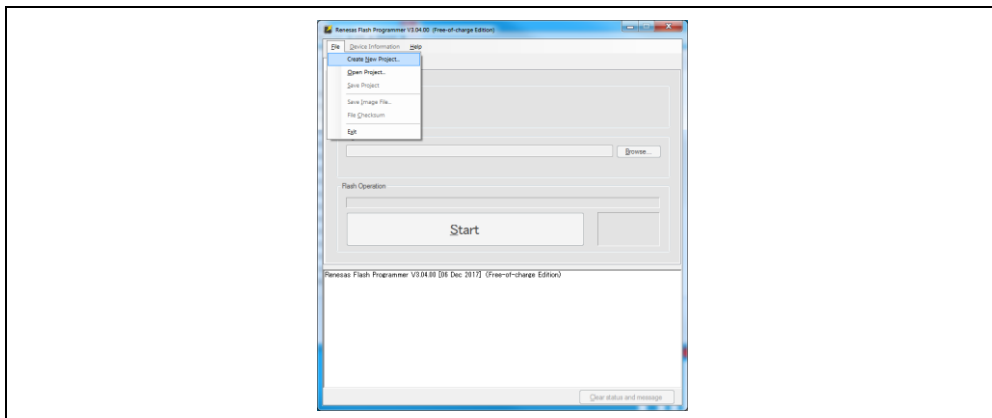

- Step 4.** From Create New Project combo box, select Microcontroller to RL78, type “Project Name”, and choose “project Folder” using “browse” button.

- Step 5.** Select “COM” from “Tool” drop-down list and choose appropriate COM port using the “Tool Detail” button. Then click “OK” button to select and “Connect” button to set “COM” port.

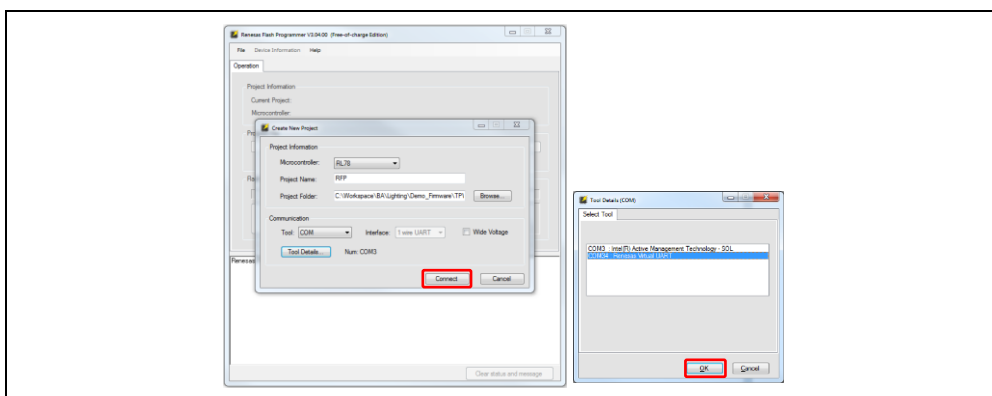



**Step 6.** Click “Browse” button for selecting Program File and select appropriate firmware HEX file from file selection dialog box. Then click “Open” button to select.

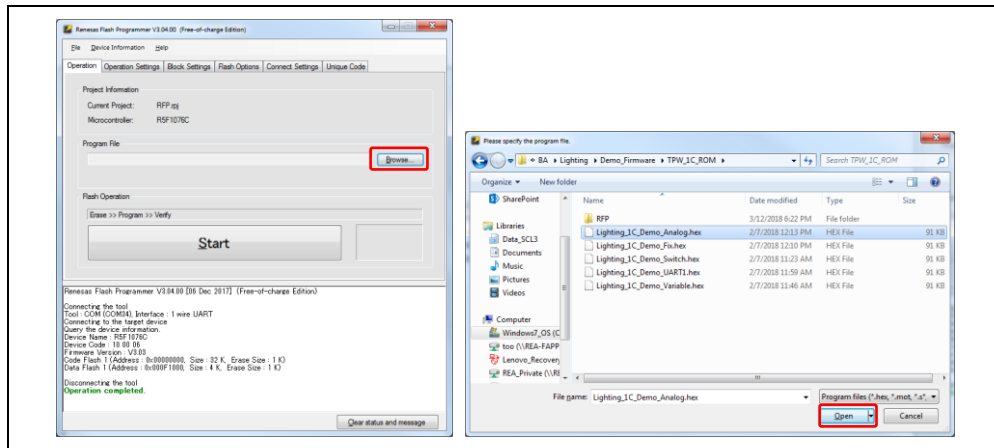

**Step 7.** Click “Start” button to program the selected firmware HEX file.

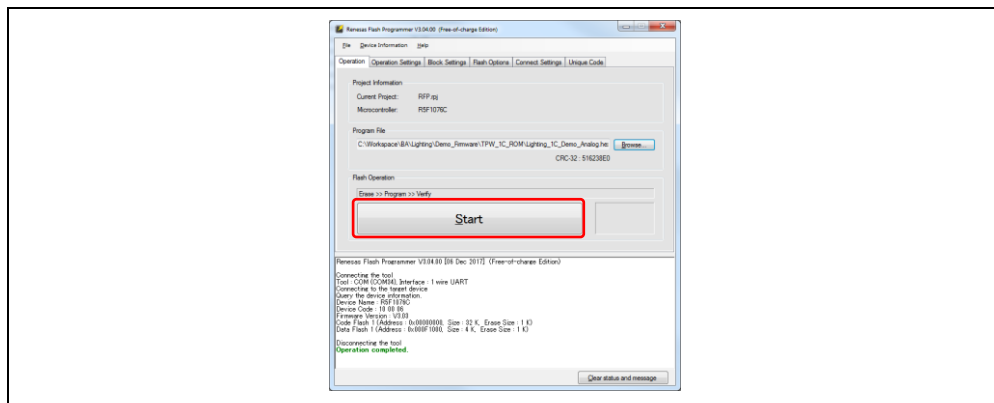

**Step 8.** Wait to complete operation. The successful operation will show the status icon in “OK” with green.

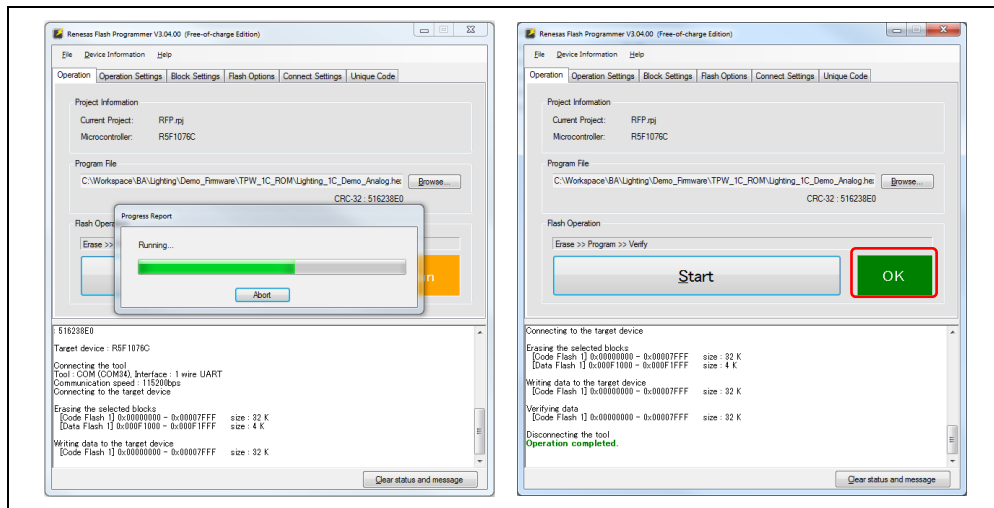

**4.2 Programming to the TPW-RL781A-2C AC/DC 2-Converter Unit**

- Step 1.** Connect between AC/DC 2-Converter unit and PC via mini USB cable.
- Step 2.** Set “OCD/Flash mode”: Configuration Switch 1 and 3 to OFF position, and 2 and 4 to ON position. Then set Debug Switch to USB (OCD) position.



- Step 3.** Open Renesas Flash Program, and create a new project from “Create New Project” “File” pulldown menu.

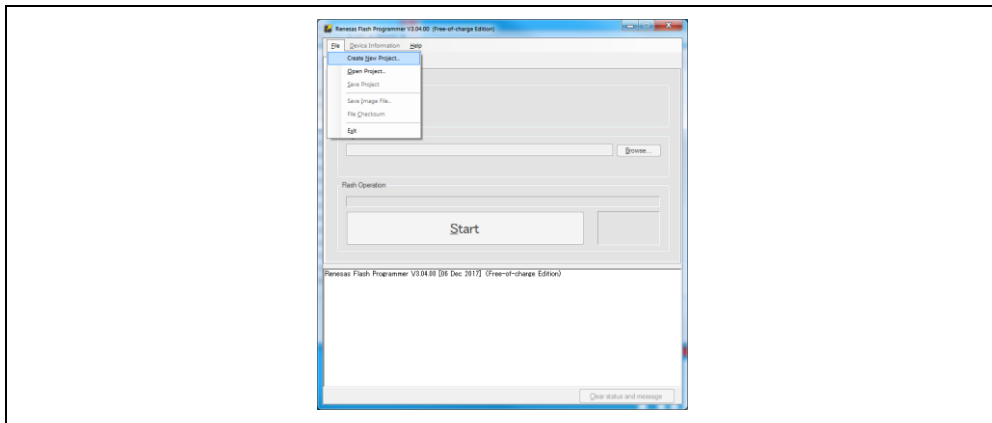

- Step 4.** From Create New Project combo box, select Microcontroller to RL78, type “Project Name”, and choose project folder using “browse” button. Then click “OK” button after selecting the project folder path.

- Step 5.** Select “COM” from “Tool” drop-down list then select appropriate COM port using the “Tool Detail” button. Then click “OK” button to select and “Connect” button to set “COM” port.

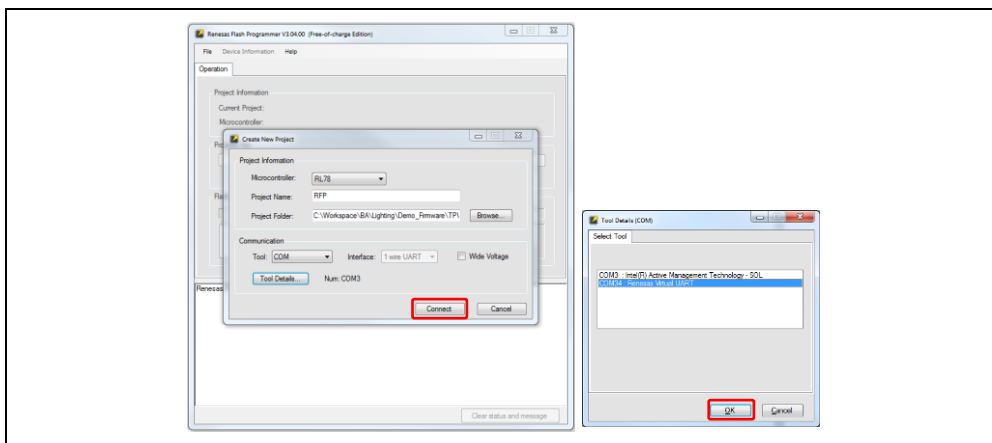

- Step 6.** Click “Browse” button for selecting Program file and select appropriate firmware HEX file from file selection dialog box. Then click “Open” button to select file.

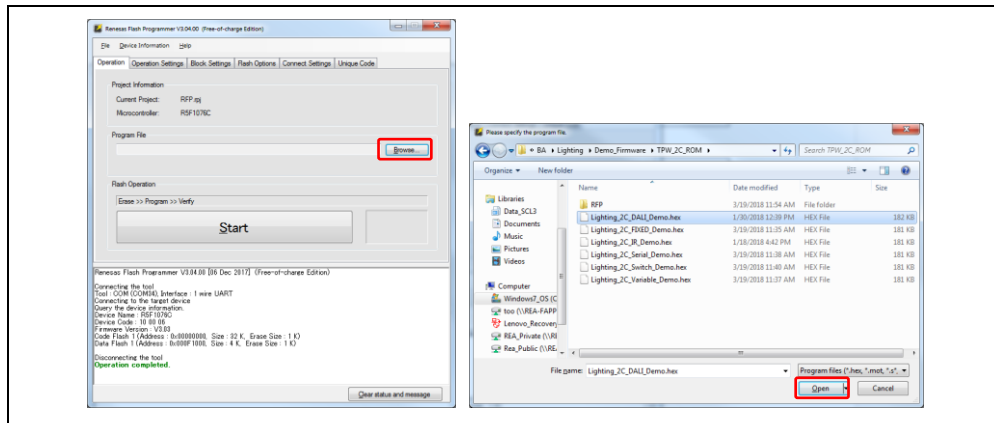

**Step 7.** Click “Start” button to program the selected firmware HEX file and wait for operation complete.

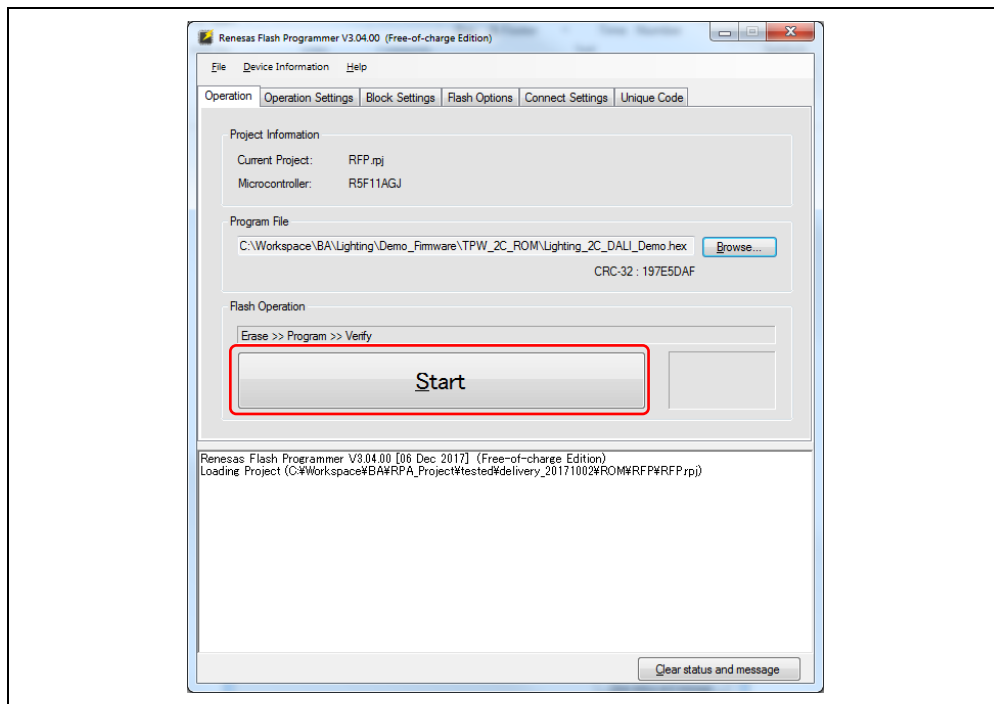

**Step 8.** The successful operation will show the status icon in “OK” with green.

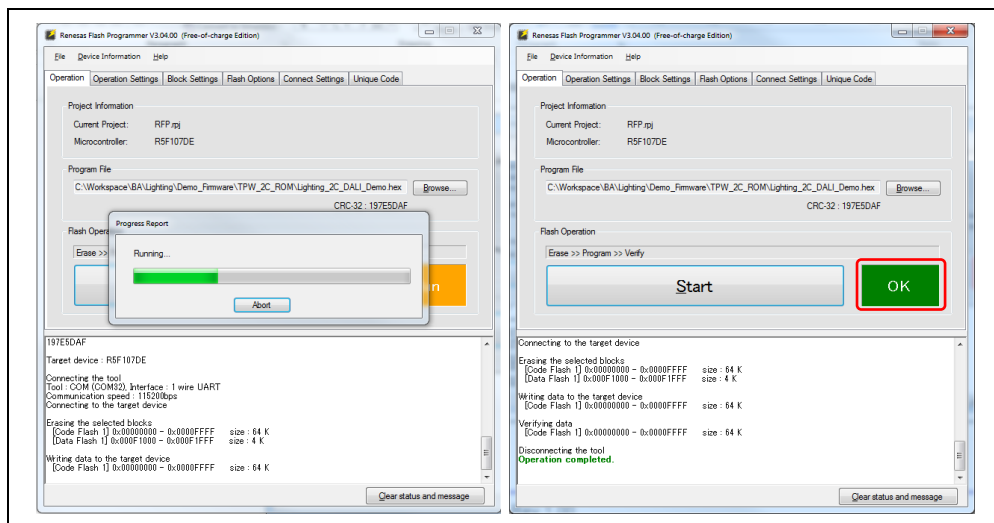

## Appendix

This section describes about how to setup and test when you program the firmware using Serial Command mode to Control Gear unit: AC/DC 1-Converter unit or AC/DC 2-Converter unit.

**Step 1.** Take out Control Gear unit and LED module from Pelican Case.

**CAUTION: Do not apply power to LED module when it is in Pelican Case.**

**Step 2.** Connect LED module to LED output connector: Red wire (labeled with +) to LED OUT (+) terminal and Black wire to LED OUT (-) terminal.

**Step 3.** Connect between Control Gear unit and PC via mini USB cable.

**Step 4.** Set “Virtual UART mode”: Configuration Switch 1 and 3 to ON position, and 2 and 4 to OFF position. Then set Debug Switch to RUN (E1) position.



**Step 5.** Open terminal application (e.g. Tera Term terminal application), and select appropriate COM port. Click “OK” button after configuration.

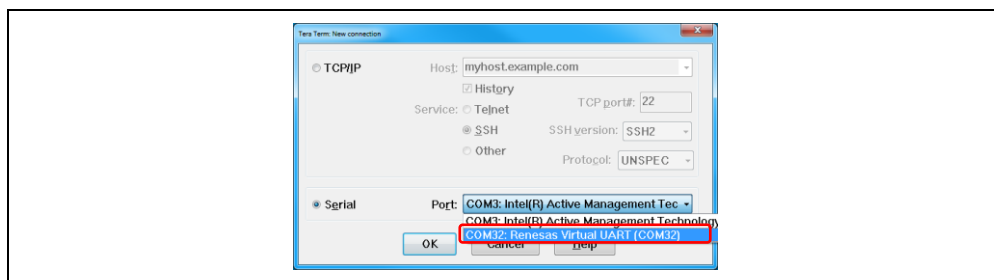

**Step 6.** Form “Setup” pulldown menu, select “Terminal”. Then configure Terminal and click “OK” button.

Receive : LF  
 Transmit : CR+LF  
 Local echo : checked

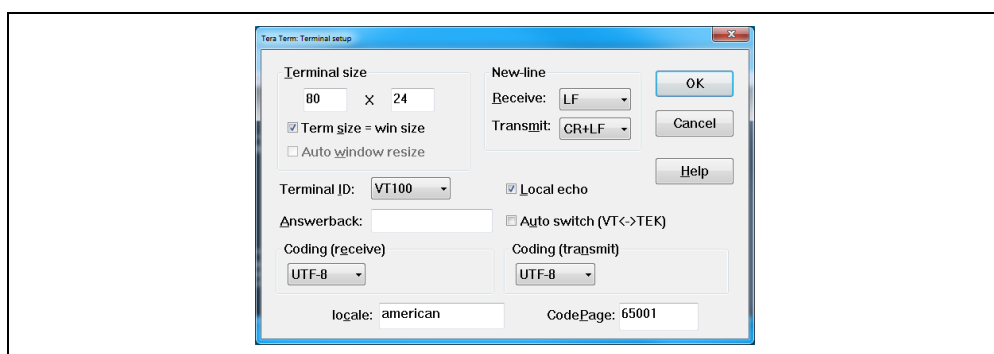

**Step 7.** Setup COM port setting form “Setup” pulldown menu and select “Serial port”. Then configure serial port setting as below. Click “OK” button after configuration.

Baud rate : 9600  
 Data : 8 bit  
 Parity : odd  
 Stop : 1 bit  
 Flow control : none

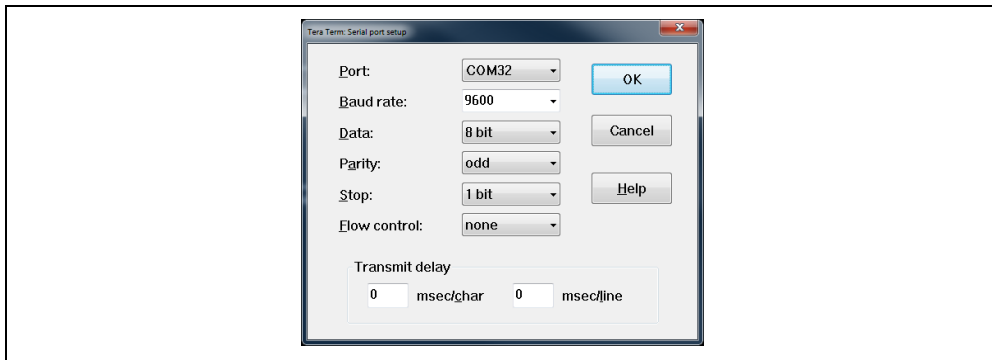

**Step 8.** Connect power cable to Converter unit and turn on the power by ON-OFF switch. RED LED (STATUS) is light on when the unit is on. The terminal shows welcome message with USAGE.

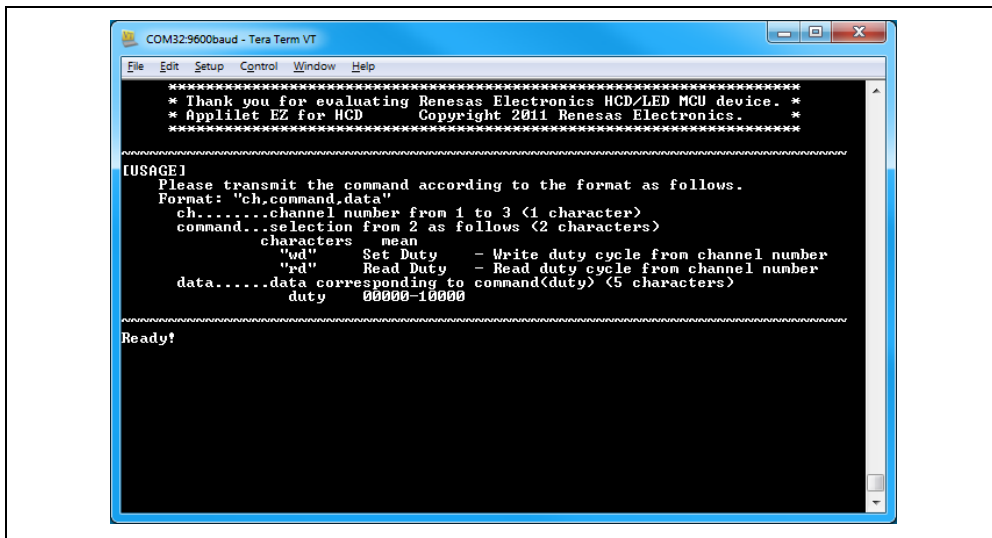

**Step 9.** Press SW switch to calibrate the newly attached LED module with Converter unit. If the LED module is within the limit of Converter unit, the RED LED will turn off. If not, it will blink to indicate the error. Press RESET switch to reset the Converter unit in case of error.

**Step 10.** Type a few commands for testing LED.

- 1,rd,00000
- 1,wd,10000
- 1,rd,00000

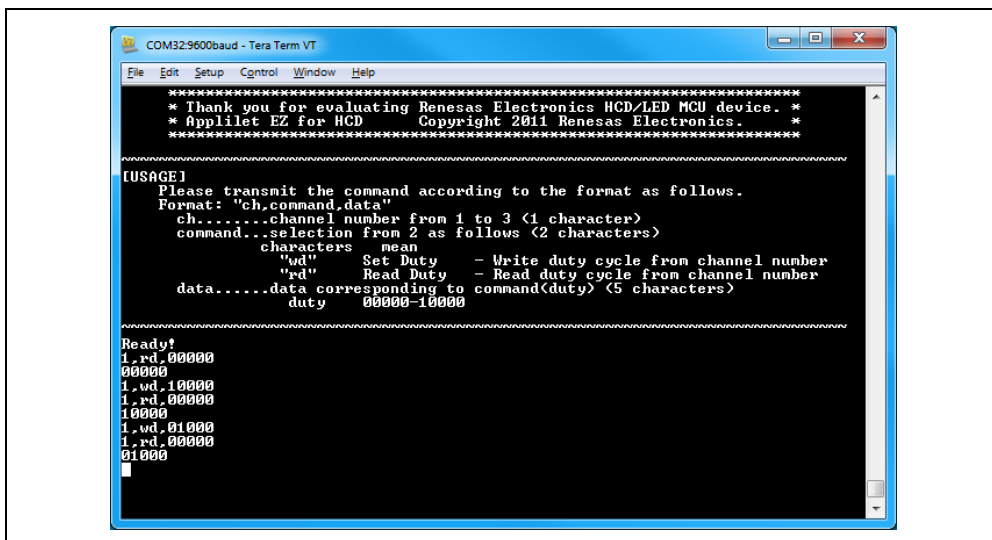

## Reference

1. **Applilet EZ for HCD**  
<https://www.renesas.com/en-us/software/D6000302.html>
2. **Applilet EZ for HCD User's Manual**  
[https://www.renesas.com/en-us/doc/products/tool/doc/005/r20ut0435ej1300\\_appliletez.pdf](https://www.renesas.com/en-us/doc/products/tool/doc/005/r20ut0435ej1300_appliletez.pdf)
3. **DALI Master Controller GUI application**  
<https://www.renesas.com/en-us/software/D6000479.html>
4. **DALI Master Controller User Manual**  
[https://www.renesas.com/en-us/doc/products/tool/doc/005/r20ut0715ej0300\\_dali.pdf](https://www.renesas.com/en-us/doc/products/tool/doc/005/r20ut0715ej0300_dali.pdf)
5. **Renesas Flash Programmer**  
<https://www.renesas.com/en-us/software/D4000660.html>

## Website and Support

Renesas Electronics Website

<http://www.renesas.com/>

Inquiries

<http://www.renesas.com/contact/>

All trademarks and registered trademarks are the property of their respective owners.



## Revision History

Rev.	Date	Description	
		Page	Summary
1.00	Apr 30, 2018	–	Initial Release

## General Precautions in the Handling of Microprocessing Unit and Microcontroller Unit Products

The following usage notes are applicable to all Microprocessing unit and Microcontroller unit products from Renesas. For detailed usage notes on the products covered by this document, refer to the relevant sections of the document as well as any technical updates that have been issued for the products.

### 1. Handling of Unused Pins

Handle unused pins in accordance with the directions given under Handling of Unused Pins in the manual.

- The input pins of CMOS products are generally in the high-impedance state. In operation with an unused pin in the open-circuit state, extra electromagnetic noise is induced in the vicinity of LSI, an associated shoot-through current flows internally, and malfunctions occur due to the false recognition of the pin state as an input signal become possible. Unused pins should be handled as described under Handling of Unused Pins in the manual.

### 2. Processing at Power-on

The state of the product is undefined at the moment when power is supplied.

- The states of internal circuits in the LSI are indeterminate and the states of register settings and pins are undefined at the moment when power is supplied.

In a finished product where the reset signal is applied to the external reset pin, the states of pins are not guaranteed from the moment when power is supplied until the reset process is completed.

In a similar way, the states of pins in a product that is reset by an on-chip power-on reset function are not guaranteed from the moment when power is supplied until the power reaches the level at which resetting has been specified.

### 3. Prohibition of Access to Reserved Addresses

Access to reserved addresses is prohibited.

- The reserved addresses are provided for the possible future expansion of functions. Do not access these addresses; the correct operation of LSI is not guaranteed if they are accessed.

### 4. Clock Signals

After applying a reset, only release the reset line after the operating clock signal has become stable. When switching the clock signal during program execution, wait until the target clock signal has stabilized.

- When the clock signal is generated with an external resonator (or from an external oscillator) during a reset, ensure that the reset line is only released after full stabilization of the clock signal. Moreover, when switching to a clock signal produced with an external resonator (or by an external oscillator) while program execution is in progress, wait until the target clock signal is stable.

### 5. Differences between Products

Before changing from one product to another, i.e. to a product with a different part number, confirm that the change will not lead to problems.

- The characteristics of Microprocessing unit or Microcontroller unit products in the same group but having a different part number may differ in terms of the internal memory capacity, layout pattern, and other factors, which can affect the ranges of electrical characteristics, such as characteristic values, operating margins, immunity to noise, and amount of radiated noise. When changing to a product with a different part number, implement a system-evaluation test for the given product.

## Notice

1. Descriptions of circuits, software and other related information in this document are provided only to illustrate the operation of semiconductor products and application examples. You are fully responsible for the incorporation or any other use of the circuits, software, and information in the design of your product or system. Renesas Electronics disclaims any and all liability for any losses and damages incurred by you or third parties arising from the use of these circuits, software, or information.
2. Renesas Electronics hereby expressly disclaims any warranties against and liability for infringement or any other claims involving patents, copyrights, or other intellectual property rights of third parties, by or arising from the use of Renesas Electronics products or technical information described in this document, including but not limited to, the product data, drawings, charts, programs, algorithms, and application examples.
3. No license, express, implied or otherwise, is granted hereby under any patents, copyrights or other intellectual property rights of Renesas Electronics or others.
4. You shall not alter, modify, copy, or reverse engineer any Renesas Electronics product, whether in whole or in part. Renesas Electronics disclaims any and all liability for any losses or damages incurred by you or third parties arising from such alteration, modification, copying or reverse engineering.
5. Renesas Electronics products are classified according to the following two quality grades: "Standard" and "High Quality". The intended applications for each Renesas Electronics product depends on the product's quality grade, as indicated below.

"Standard": Computers; office equipment; communications equipment; test and measurement equipment; audio and visual equipment; home electronic appliances; machine tools; personal electronic equipment; industrial robots; etc.

"High Quality": Transportation equipment (automobiles, trains, ships, etc.); traffic control (traffic lights); large-scale communication equipment; key financial terminal systems; safety control equipment; etc.

Unless expressly designated as a high reliability product or a product for harsh environments in a Renesas Electronics data sheet or other Renesas Electronics document, Renesas Electronics products are not intended or authorized for use in products or systems that may pose a direct threat to human life or bodily injury (artificial life support devices or systems; surgical implantations; etc.), or may cause serious property damage (space system; undersea repeaters; nuclear power control systems; aircraft control systems; key plant systems; military equipment; etc.). Renesas Electronics disclaims any and all liability for any damages or losses incurred by you or any third parties arising from the use of any Renesas Electronics product that is inconsistent with any Renesas Electronics data sheet, user's manual or other Renesas Electronics document.

6. When using Renesas Electronics products, refer to the latest product information (data sheets, user's manuals, application notes, "General Notes for Handling and Using Semiconductor Devices" in the reliability handbook, etc.), and ensure that usage conditions are within the ranges specified by Renesas Electronics with respect to maximum ratings, operating power supply voltage range, heat dissipation characteristics, installation, etc. Renesas Electronics disclaims any and all liability for any malfunctions, failure or accident arising out of the use of Renesas Electronics products outside of such specified ranges.
7. Although Renesas Electronics endeavors to improve the quality and reliability of Renesas Electronics products, semiconductor products have specific characteristics, such as the occurrence of failure at a certain rate and malfunctions under certain use conditions. Unless designated as a high reliability product or a product for harsh environments in a Renesas Electronics data sheet or other Renesas Electronics document, Renesas Electronics products are not subject to radiation resistance design. You are responsible for implementing safety measures to guard against the possibility of bodily injury, injury or damage caused by fire, and/or danger to the public in the event of a failure or malfunction of Renesas Electronics products, such as safety design for hardware and software, including but not limited to redundancy, fire control and malfunction prevention, appropriate treatment for aging degradation or any other appropriate measures. Because the evaluation of microcomputer software alone is very difficult and impractical, you are responsible for evaluating the safety of the final products or systems manufactured by you.
8. Please contact a Renesas Electronics sales office for details as to environmental matters such as the environmental compatibility of each Renesas Electronics product. You are responsible for carefully and sufficiently investigating applicable laws and regulations that regulate the inclusion or use of controlled substances, including without limitation, the EU RoHS Directive, and using Renesas Electronics products in compliance with all these applicable laws and regulations. Renesas Electronics disclaims any and all liability for damages or losses occurring as a result of your noncompliance with applicable laws and regulations.
9. Renesas Electronics products and technologies shall not be used for or incorporated into any products or systems whose manufacture, use, or sale is prohibited under any applicable domestic or foreign laws or regulations. You shall comply with any applicable export control laws and regulations promulgated and administered by the governments of any countries asserting jurisdiction over the parties or transactions.
10. It is the responsibility of the buyer or distributor of Renesas Electronics products, or any other party who distributes, disposes of, or otherwise sells or transfers the product to a third party, to notify such third party in advance of the contents and conditions set forth in this document.
11. This document shall not be reprinted, reproduced or duplicated in any form, in whole or in part, without prior written consent of Renesas Electronics.
12. Please contact a Renesas Electronics sales office if you have any questions regarding the information contained in this document or Renesas Electronics products.

(Note 1) "Renesas Electronics" as used in this document means Renesas Electronics Corporation and also includes its directly or indirectly controlled subsidiaries.

(Note 2) "Renesas Electronics product(s)" means any product developed or manufactured by or for Renesas Electronics.

(Rev.4.0-1 November 2017)



### SALES OFFICES

Renesas Electronics Corporation

<http://www.renesas.com>

Refer to "<http://www.renesas.com/>" for the latest and detailed information.

#### **Renesas Electronics America Inc.**

1001 Murphy Ranch Road, Milpitas, CA 95035, U.S.A.  
Tel: +1-408-432-8888, Fax: +1-408-434-5351

#### **Renesas Electronics Canada Limited**

9251 Yonge Street, Suite 8309 Richmond Hill, Ontario Canada L4C 9T3  
Tel: +1-905-237-2004

#### **Renesas Electronics Europe Limited**

Dukes Meadow, Millboard Road, Bourne End, Buckinghamshire, SL8 5FH, U.K  
Tel: +44-1628-651-700, Fax: +44-1628-651-804

#### **Renesas Electronics Europe GmbH**

Arcadiastrasse 10, 40472 Düsseldorf, Germany  
Tel: +49-211-6503-0, Fax: +49-211-6503-1327

#### **Renesas Electronics (China) Co., Ltd.**

Room 1709 Quantum Plaza, No.27 ZhichunLu, Haidian District, Beijing, 100191 P. R. China  
Tel: +86-10-8235-1155, Fax: +86-10-8235-7679

#### **Renesas Electronics (Shanghai) Co., Ltd.**

Unit 301, Tower A, Central Towers, 555 Langao Road, Putuo District, Shanghai, 200333 P. R. China  
Tel: +86-21-2226-0888, Fax: +86-21-2226-0999

#### **Renesas Electronics Hong Kong Limited**

Unit 1601-1611, 16/F., Tower 2, Grand Century Place, 193 Prince Edward Road West, Mongkok, Kowloon, Hong Kong  
Tel: +852-2265-6688, Fax: +852 2886-9022

#### **Renesas Electronics Taiwan Co., Ltd.**

13F, No. 363, Fu Shing North Road, Taipei 10543, Taiwan  
Tel: +886-2-8175-9600, Fax: +886 2-8175-9670

#### **Renesas Electronics Singapore Pte. Ltd.**

80 Bendemeer Road, Unit #06-02 Hyflux Innovation Centre, Singapore 339949  
Tel: +65-6213-0200, Fax: +65-6213-0300

#### **Renesas Electronics Malaysia Sdn.Bhd.**

Unit 1207, Block B, Menara Amcorp, Amcorp Trade Centre, No. 18, Jln Persiaran Barat, 46050 Petaling Jaya, Selangor Darul Ehsan, Malaysia  
Tel: +60-3-7955-9390, Fax: +60-3-7955-9510

#### **Renesas Electronics India Pvt. Ltd.**

No.777C, 100 Feet Road, HAL 2nd Stage, Indiranagar, Bangalore 560 038, India  
Tel: +91-80-67208700, Fax: +91-80-67208777

#### **Renesas Electronics Korea Co., Ltd.**

17F, KAMCO Yangjae Tower, 262, Gangnam-daero, Gangnam-gu, Seoul, 06265 Korea  
Tel: +82-2-558-3737, Fax: +82-2-558-5338