

Part One: Why use Coupled Inductors?

1.0 Description

This paper describes the step by step process wherein a multiphase interleaved buck converter, which originally uses non-coupled inductors, is modified to use coupled inductors resulting in significant *efficiency increase* and *improved transient response* at the same time.

2.0 Non-Coupled Inductor Reference Circuit Design

An example of a multiphase synchronous buck converter that can be used to power a microprocessor load is illustrated in **Fig. 1**. The converter has 5 phases and uses discrete (non-coupled) inductors.

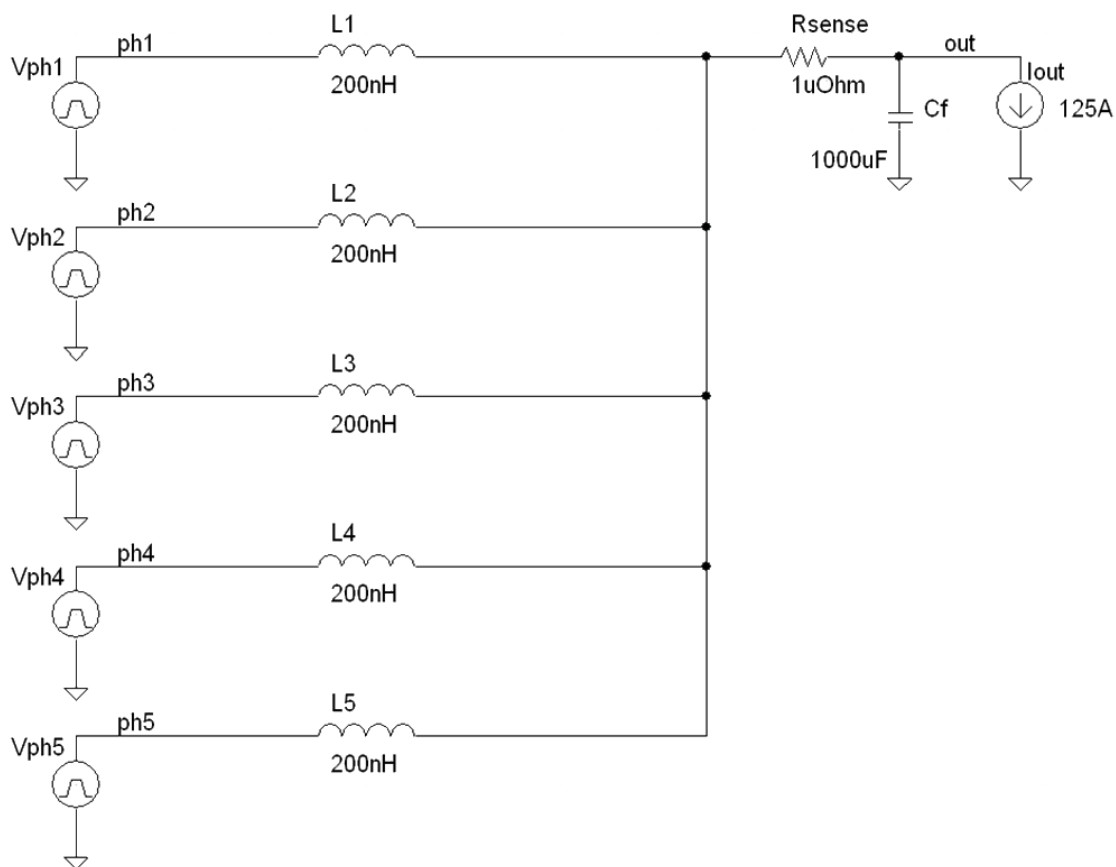

Fig. 1: 5-phase interleaved buck converter

In this example:

- **Vph1** to **Vph5** represent phase voltages as generated by MOSFETs switching at 500 kHz. The wave forms at each **Vph** are shown in **Fig. 2**.
- **L1** to **L5** are non-coupled inductors which work in cooperation with the filter capacitor **Cf** to provide a well filtered voltage at the converter's output. The total load current **Iout** is 125A, which is fairly typical for a 5 phase converter.
- **Rsense** is used in the SPICE model to monitor the sum of the phase currents.

The Case For Coupled Inductor In Multiphase Buck Converters

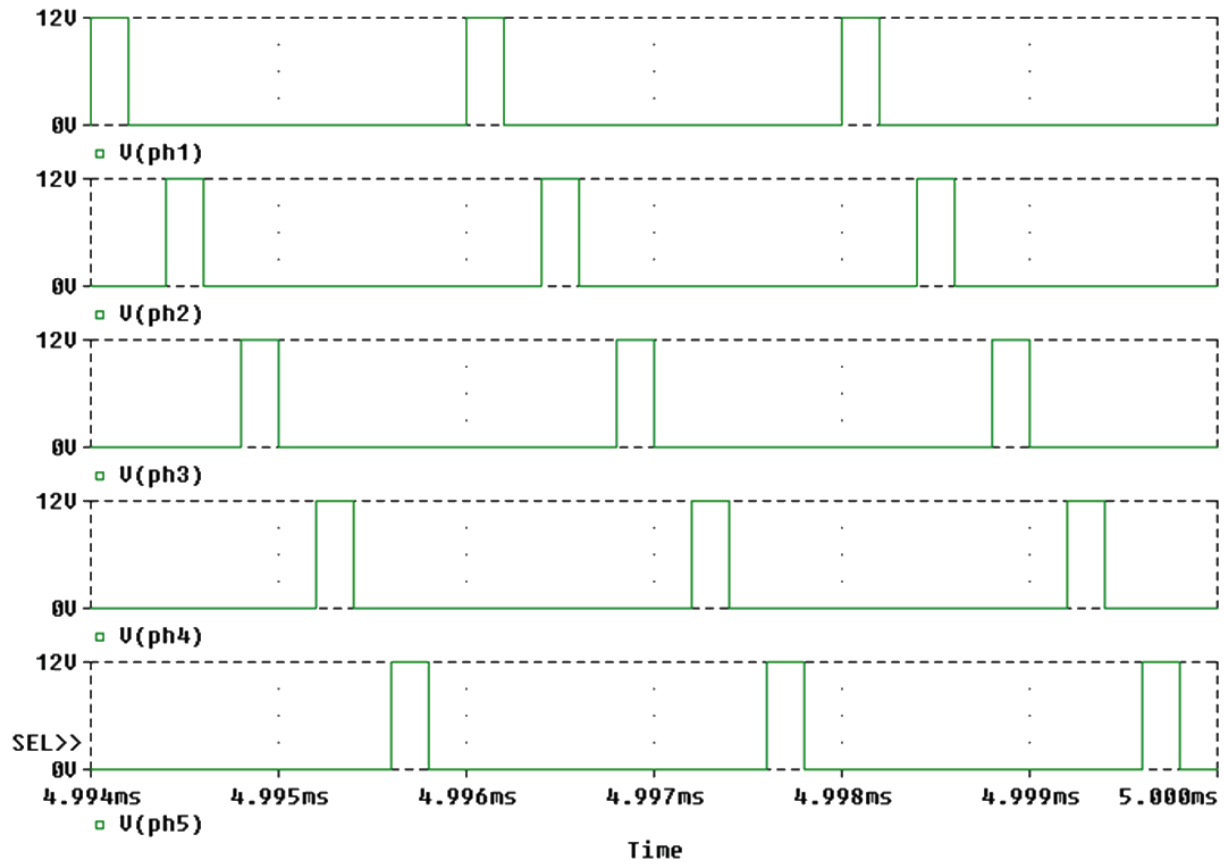

Fig. 2: Phase Voltages

Fig. 3 shows each phase current, the sum of the phase currents and the output voltage ripple.

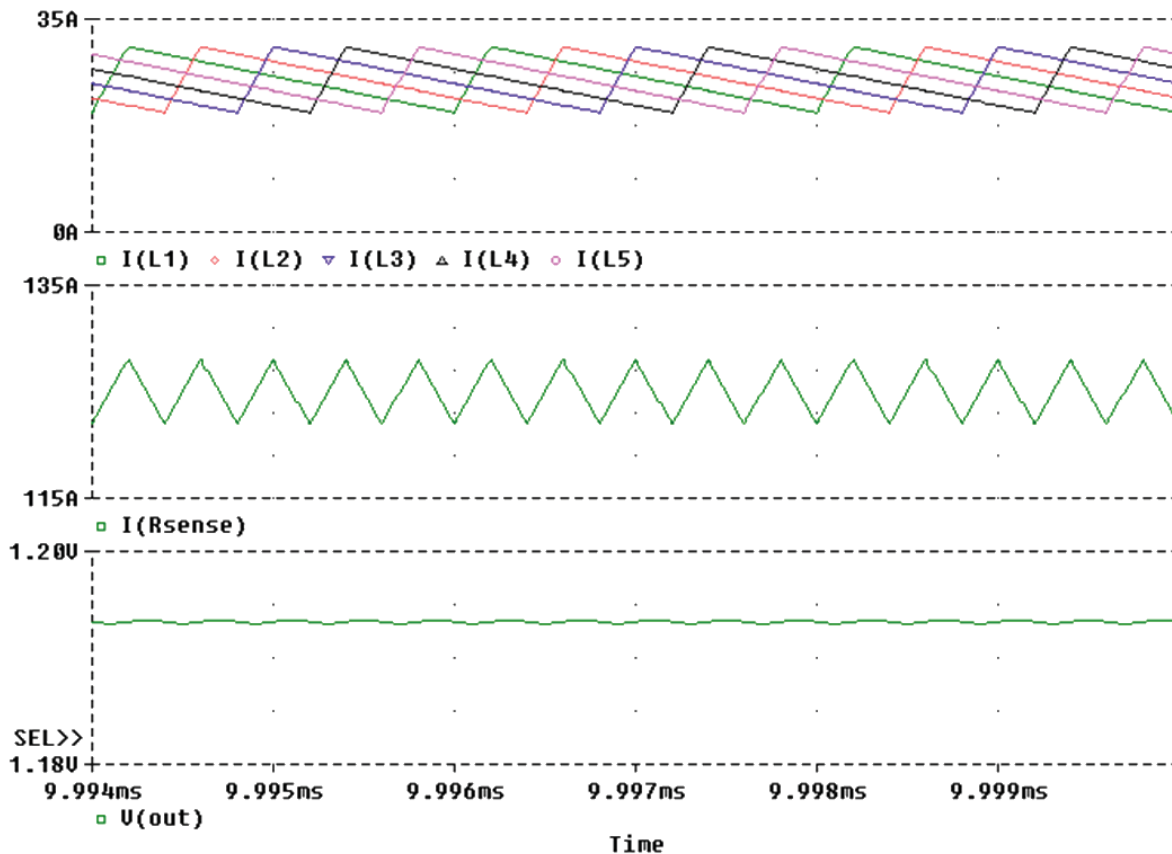

Fig. 3: Phase currents, sum of phase currents and output voltage ripple for non-coupled inductors

Notes (refer to **Fig. 3**):

- The values of the phase inductors together with the switching frequency were chosen to keep the peak phase ripple currents at an acceptable value. There are two reasons to limit the phase current ripple:
 - 1) The turn-off switching losses in the top MOSFET are proportional to the peak phase current (squared).
 - 2) The conduction losses in the power MOSFETs are proportional to the RMS of the phase current (squared).

In this particular case, the peak to peak ripple current of each phase is about 43% (11App) of the average current per phase (25A). This gives a fair compromise between the sizes of the phase inductors on the one hand and turn-off switching losses along with phase conduction losses on the other hand.
- The output voltage ripple is only 0.3mV. This is much lower than normally required in such applications. The reason for the output ripple being so low is the size chosen for the output filter capacitance **C_f**. In fact, the size of the filter capacitor is not dictated by the output voltage ripple, but by control loop stability and load transient response requirements. The 1000uF value is one of the lowest encountered in most applications.

3.0 Circuit Design and Performance Effects by Coupling Inductors

The following will explain how to decrease the phase switching frequency *without increasing the phase current ripple*. This results directly in an efficiency increase.

On the other hand, the load transient response will improve at the same time. The output voltage ripple will also increase, however as indicated above there is significant room for output voltage ripple increase.

Going back to the SPICE model from **Fig. 1**, negative magnetic couplings will be added between inductors **L1** to **L5**, in a ring fashion (i.e. **L1** coupled to **L2** and **L2** coupled to **L3**, and... **L5** coupled to **L1**).

The coupling factors have been chosen arbitrarily small ($k = -0.35$), to observe the effect on the various ripples. In a SPICE model, the magnetic coupling factor of a pair of inductors is related to the ratio between the leakage inductance between the first inductor and the second inductor on the one hand, and the self inductance of the first inductor on the other hand. The leakage inductance between the first inductor and the second inductor is defined as the inductance of the first inductor when the terminals of the second inductor are shorted together.

The formula for coupling factor is:

$$L_{leak}/L_{self} = 1 - k^2$$

A negative coupling factor indicates the fact that a positive applied voltage on one of the inductors will generate a negative voltage across the second inductor. In SPICE, the inductor symbols are 'oriented', so there is a node 1 and a node 2, apparent from the way the symbol is drawn.

The new model is shown in **Fig. 4**.

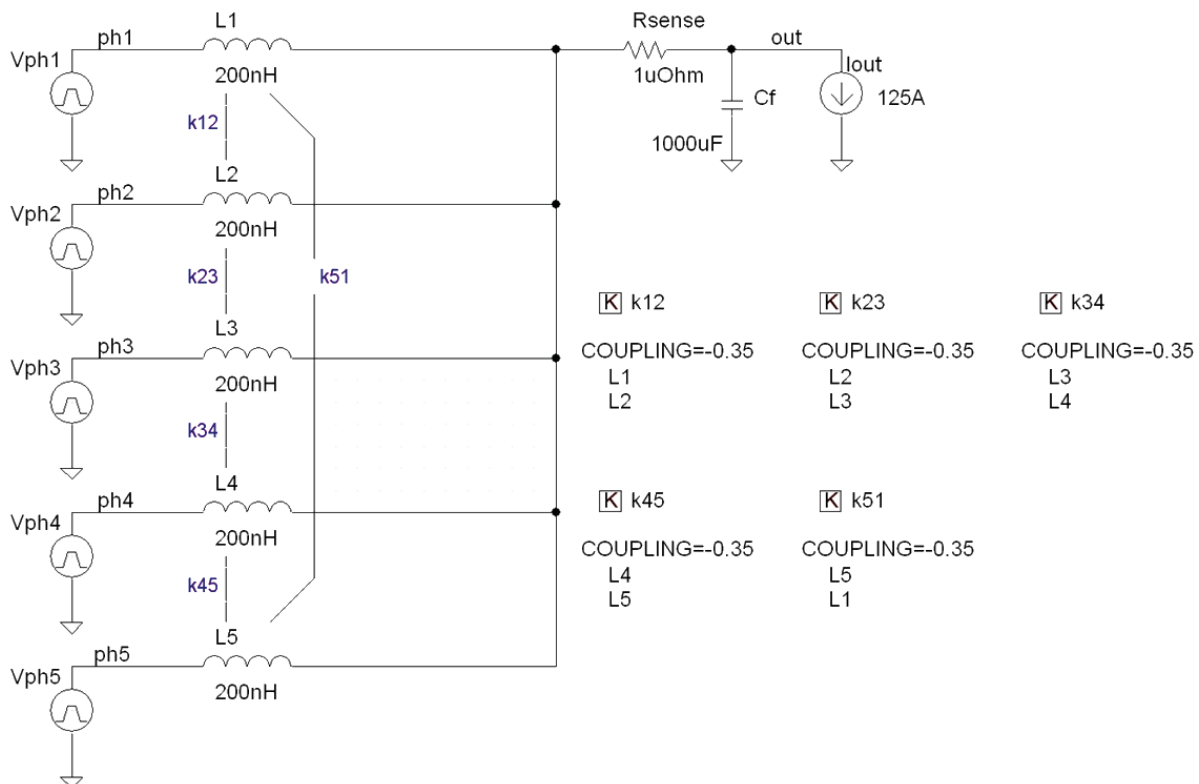
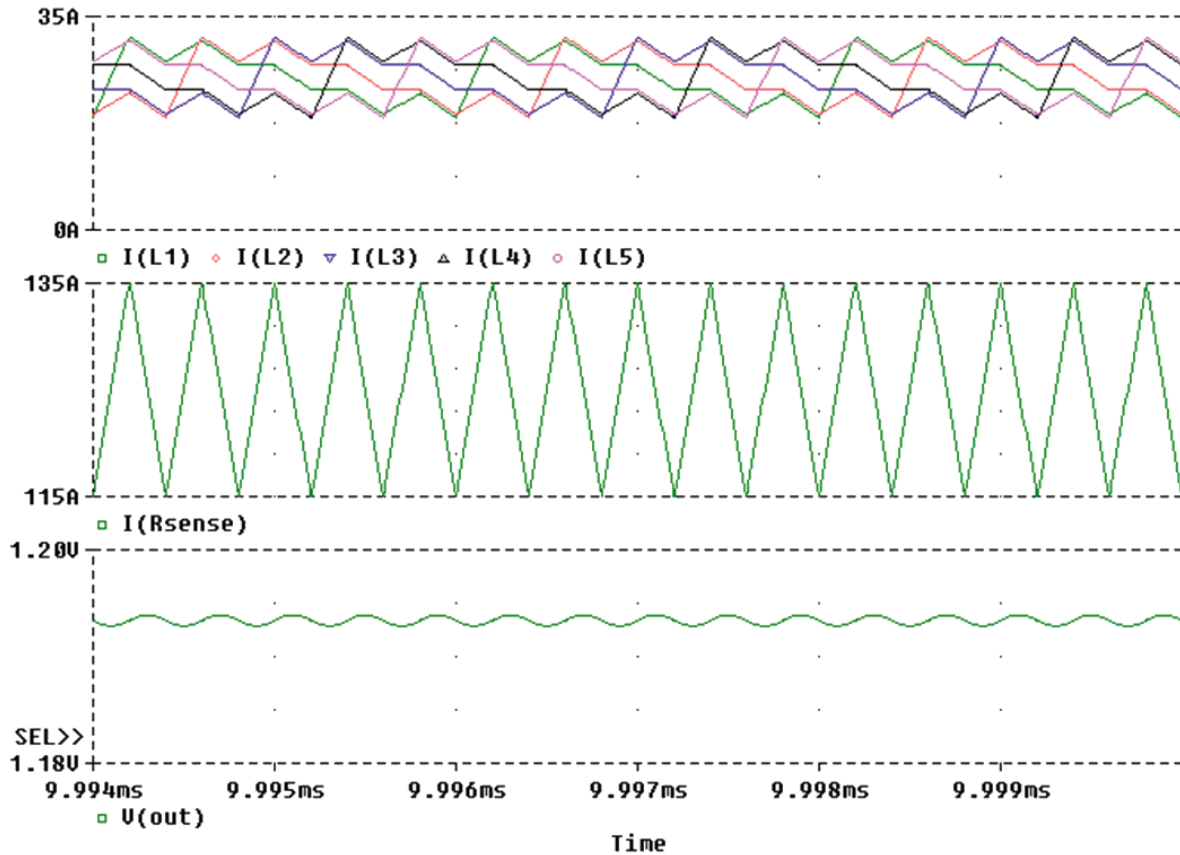

Fig. 4: 5-phase interleaved buck converter with slightly coupled inductors

After simulating the same waveforms as in **Fig. 3**, it can be seen in **Fig. 5** that after the inductors have been slightly coupled, with negative couplings and in a ring fashion:

- The phase ripple currents increased very slightly
- The total phase current ripple increased strongly
- The output voltage ripple increased visibly as well, although it is still OK for normal applications



**Fig. 5: Phase currents, sum of phase currents
and output voltage ripple for slightly coupled inductors**

Numerically, the total combined phase current (as seen from the output side) increased more than 5 times faster than the phase ripple current (as seen from the phase side). In electrical network terms, the effect of coupling the inductors in the described fashion is an *insignificant decrease* of the input impedance at the same time with a *strong decrease* of the output impedance of the combination of five inductors.

If desired, the phase current ripples can be brought back to the original value by simply increasing the **L1** to **L5** inductances while preserving the coupling factors. The phase ripple will be the same as for the original non-coupled inductors, but the output sum of the inductor ripples will still be about 5 times higher than the original non-coupled inductors.

Moreover, one can further increase the value of the **L1** to **L5** inductors to reduce the phase current ripples under the original value for the non-coupled inductors. The last step after this will be to reduce the switching frequency of all phases in order to match the original ripple currents for the non-coupled inductors (as in **Fig. 3**). At the end of this process, the converter using coupled inductors will have the same phase current ripple as the original non-coupled inductor at a reduced switching frequency (only 250 kHz) which amounts for a boost in efficiency. It will also have smaller output impedance, which amounts for a faster transient response. The only parameter which will be 'sacrificed' is the output voltage ripple – nevertheless this will be OK for most related applications.

The Case For Coupled Inductor In Multiphase Buck Converters

Fig. 6 shows a coupled inductor configuration which results at the end of the previously described sequence of changes. **Fig. 7** shows the associated ripple waveforms for comparison with **Fig. 3**.

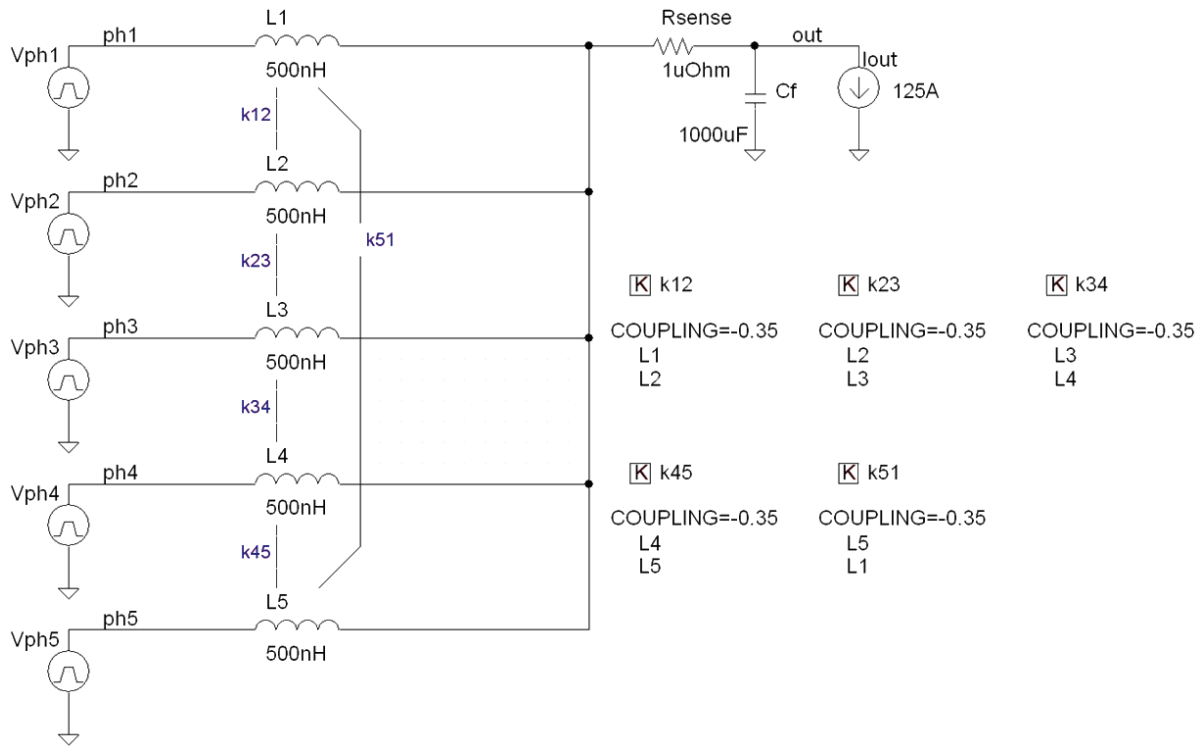
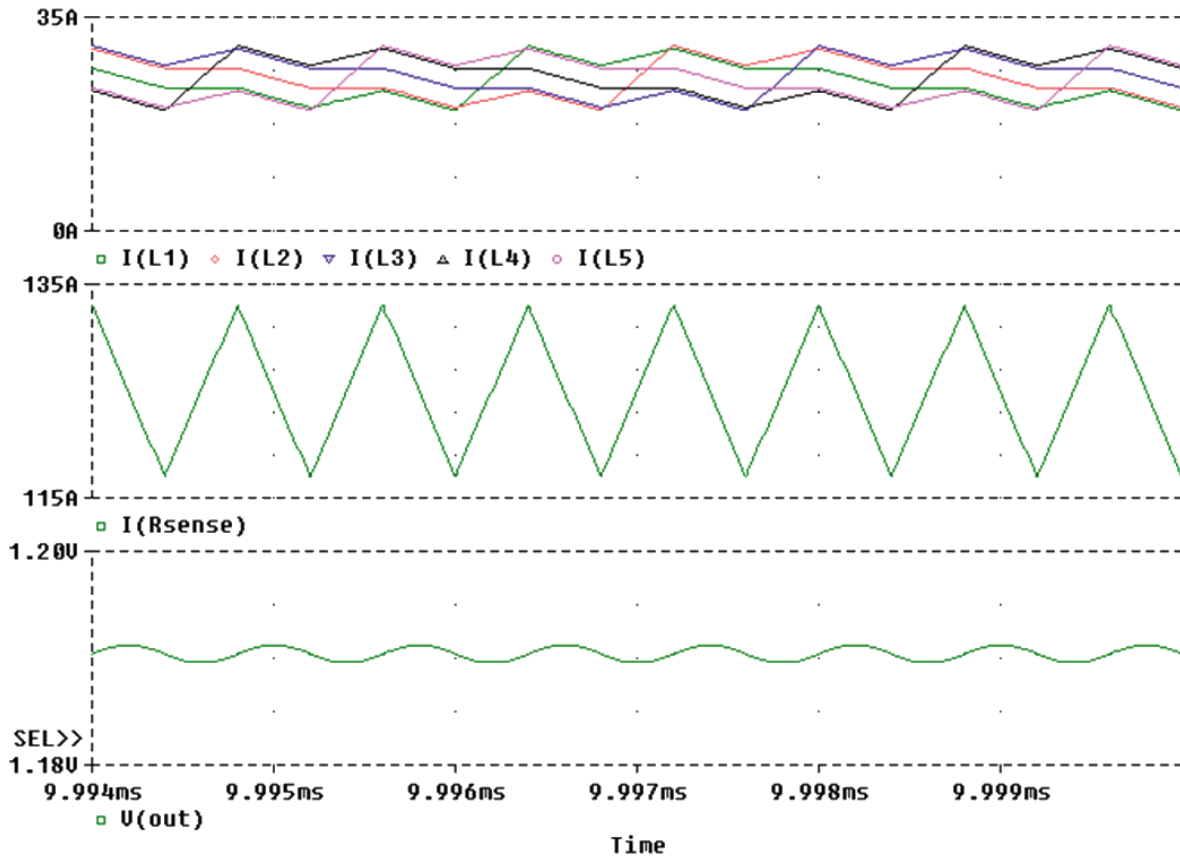

Fig. 6: The buck converter with coupled inductors at the end of the transformation process



**Fig. 7: Phase currents, sum of phase currents
and output voltage ripple of the final converter**

The Case For Coupled Inductor In Multiphase Buck Converters

The iterative process is summarized in the following table:

Step #	Description of step	Inductor value	Magnetic coupling	Switching frequency	Phase current ripple	Output voltage ripple	Efficiency	Transient response
1	Reference	200nH	0	500kHz	11App	0.3mVpp	Ref	Ref
2	Introduced negative magnetic coupling in a ring fashion	200nH	-0.35	500kHz	12App	0.99mVpp		
3	Increased inductance to match reference phase ripple current	220nH	-0.35	500kHz	11App	0.9Vpp		
4	Increased inductance	500nH	-0.35	500kHz	5.5App	0.4mVpp		
5	Decreased switching frequency	500nH	-0.35	250kHz	11App	1.6mVpp	Higher	Faster

Or, to detail results without all of the intermediate steps:

Description	Inductor value	Magnetic coupling	Switching frequency	Phase current ripple	Output voltage ripple	Efficiency	Transient response
Non-coupled inductor	200nH	0	500kHz	11App	0.3mVpp	Ref	Ref
Negatively coupled inductor in a ring fashion	500nH	-0.35	250kHz	11App	1.6mVpp	Higher	Faster

4.0 Conclusion

In summary, when going from a non-coupled inductor solution to a negatively coupled in a ring fashion solution, one can work at lower switching frequency (higher efficiency) and achieve faster load transient response. The only penalty, perfectly acceptable in most cases, is an increase of the output voltage ripple.

Part Two of this paper, [IKOR Coupled Inductor Implementation](#), will show practical implementations of the IKOR coupled inductor.

The Case For Coupled Inductor In Multiphase Buck Converters



About IKOR

IKOR, an iWatt Company, is a technology-driven supplier of power delivery solutions for original equipment manufacturers (OEMs) in the high-end computing, data communications and automated test equipment markets. IKOR products are designed and manufactured to exceed the rigorous performance, quality, and reliability requirements of our globally-recognized, top-tier customers.

Patent and Trademark Information

©2008 iWatt, Inc. All rights reserved. iWatt, the iW light bulb, IKOR, and POWER BRICK are registered trademarks of iWatt, Inc. All other trademarks and registered trademarks are the property of their respective owners.

The products and technology described in this data sheet include intellectual property covered by one or more of the following U.S. patents: 6,545,450; 6,686,727; 6,696,823. Purchase of this product from IKOR includes a royalty-free license to use and sell the intellectual property in the customer's end product on a per-unit basis. In no way does this license extend to customer end products which do not use this product to implement the intellectual property.

IKOR Contact Information

Web: <http://www.iWatt.com>

E-mail: sales@iWatt.com

Phone: 970-282-6200

Fax: 970-206-0716

IKOR, An iWatt Company

4424 Innovation Drive
Fort Collins, CO 80525 USA

Disclaimer

IKOR reserves the right to make changes to its products and to discontinue products without notice. IKOR makes no warranties other than those listed in its standard terms and conditions of sale and disclaims any implied warranties of non-infringement of third-party intellectual property rights.

Certain applications may involve potential risks of death, personal injury, or severe property or environmental damage ("Critical Applications").

IKOR PRODUCTS ARE NOT DESIGNED, INTENDED, AUTHORIZED, OR WARRANTED TO BE SUITABLE FOR USE IN LIFE-SUPPORT APPLICATIONS, DEVICES OR SYSTEMS, OR OTHER CRITICAL APPLICATIONS.

Inclusion of IKOR products in critical applications is understood to be fully at the risk of the customer. Questions concerning potential risk applications should be directed to IKOR.