



Mobile

January 2020



LEADER IN POWER SOLUTIONS FOR SMARTPHONES

Dialog's power management solutions are optimized to meet the challenging needs of today's smartphones. Tight space constraints, thermal challenges and ever changing power requirements are effectively addressed through Dialog's portfolio of highly integrated, highly efficient and easily configurable PMICs.

Dialog also offers innovative, highly efficient and high-density charging solutions that reduce heat dissipation for any rapid charging technology.

Development Support

Throughout the customer product development period, Dialog provides quick and expert application support. Dialog's local field application engineers are always on hand to provide dedicated advice and guidance during the critical design phase.

Contents

- Custom Mixed-Signal Solutions.....Page 04
- Power management ICsPage 06
- Switched Capacitor DC-DC ConvertersPage 11
- Smartphone charging ICsPage 13
- Power conversion solutionsPage 15
- HapticsPage 24

Power Management ICs (PMICs)

Highly integrated, efficient and scalable power management ICs (PMICs) and sub-PMICs for powering SOCs

Charging ICs

High efficiency companion charger ICs, requiring no external inductors

Haptics

Low-power, wide-bandwidth haptic driver for vibrations and clicks using ERM (eccentric rotating mass motor) and LRA (linear resonant actuator) applications

Custom Mixed-Signal Solutions

Market leading Custom PMICs and Mixed-Signal ASICs deliver customized solutions to optimize efficiency, size, performance and system cost

AC/DC RapidCharge™ adapter solutions

Higher power density in smaller travel adapters without incurring thermal issues



Capacitive Dividers

The industry's first and highest efficiency Switch Cap Converters with extremely small footprint enabling 2S to 1S voltage conversions without requiring inductors

Custom Mixed-Signal Solutions

Dialog Semiconductor, a market leader in custom Power Management ICs (PMICs) and Mixed-Signal ASICs, has a proven track record and long history in its close collaboration with industry leaders to deliver customized, high-performance solutions. The company's exemplary record has resulted in multi-generational partnerships which have firmly established Dialog as a trusted partner of choice.

Integrate to Differentiate

Dialog enables many of the most unique and advanced electronics products on the market today. Its broad, mixed-signal portfolio ranges from advanced power conversion topologies, battery chargers, audio solutions, digital and analog interfaces to linear analog and signal conditioning technologies. Dialog's digital capabilities include embedded computing as well as memory to empower next generation solutions. Advanced packaging technologies co-developed with the company's packaging experts and vendor partners continue to deliver leading edge solutions in the mixed-signal market.

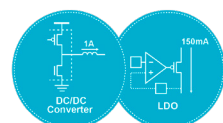

Power Management

- DC/DC Converters
 - Buck
 - Boost
 - Buck-Boost
- Hybrid Converters
- Switch-Cap Converters
- LDOs

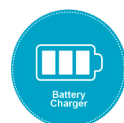

Battery Chargers

- Linear Charging
- Switchmode Charging
- Direct Charging
- Current Doublers/Voltage Dividers
- Power Path Management



Audio

- Audio Amps
- Audio Codecs
- Audio Processors
- Integrated Power and Audio Solutions



Interface

- USB Phy
- Type-C Controller
- I2C/I3C
- SPI
- UART
- Display Drivers

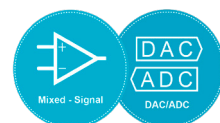

Linear Analog & Signal Conditioning

- ADC
- DAC
- Op-Amps
- Comparators
- References
- Sensor Interface
- Integrated Motor Drivers

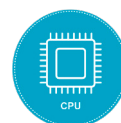

Computing

- CPU/MCU
 - ARM
 - 8051
 - DSP
 - Custom
- Memory
 - Flash
 - OTP
 - MTP

Time-to-Market

Dialog is now the leading pure play provider of advanced Power Management ICs. This level of success was achieved through absolute attention to detail. Dialog ensures that all IP is proven to perform as designed. Its accumulated library of leading-edge technologies enables Dialog to execute flawlessly and deliver "First Time Right" solutions.

Operational Excellence

Dialog's long-standing relationships with world-class manufacturing partners for wafer fabrication back-end assembly and test provide access to advanced mixed signal process nodes. Expertise in mixed-signal ASIC design and development from concept to production guarantees the highest levels of quality.

Dialog's unparalleled high-volume production ramp capability (from zero to 80 M units within a quarter) empowers its customers to rapidly deliver new products to market. The internal supply chain team at Dialog has delivered 99%+ on-time-delivery (OTD) while working closely to react to today's dynamic and volatile market conditions.

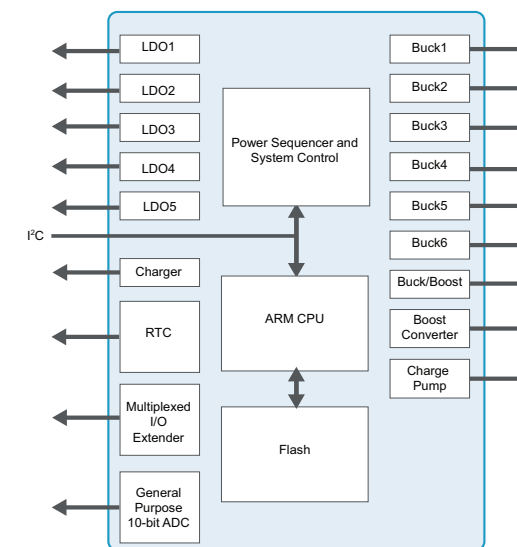

A representative example of a high-performance Custom ASIC in production

Power management ICs

Highly integrated solutions offer space saving and cost-effective smartphone solutions

The integration of multiple switching regulators and LDOs meets the diverse power management needs of advanced SOCs and conserves valuable board space. Additionally, these highly integrated solutions deliver higher reliability, reduced complexity and provide layout flexibility.

Flexible and configurable for multiple SOC platforms

Dialog's comprehensive solutions meet the challenges of powering today's advanced application processor and modem SOCs with diverse voltage and current needs, multiple channels, power sequencing requirements and the ability to scale to higher power needs.

PMIC and sub-PMIC families meet wide-ranging needs in today's applications

In addition to highly integrated PMIC solutions with integrated multiple buck regulators and LDOs, Dialog offers a family of high-current sub-PMICs that satisfy the high-current needs of the latest SOCs. These sub-PMICs offer multi-phase, high-current (up to 20 A) buck regulators in a compact footprint with advanced power management features.



System PMIC Product Portfolio

Product	Package	Input Voltage (V)	Regulators	LDOs	ADC	USB charger	RTC	Interface	GPIOs	Backup charger	LED boost	Watchdog	Audio Amplifier (Class G, Class D)	Audio Codec
DA9021	WLCSP	2.8 to 5.5	3	5	Y	Y	Y	I ² C, SPI	9	-	-	-	-	-
DA9022	WLCSP	2.8 to 5.5	3	5	Y	Y	Y	I ² C, SPI	9	-	-	-	-	-
DA9053	VBGA	2.8 to 5.5	4	10	Y	Y	Y	I ² C, SPI	16	Y	Y	Y	-	-
DA9061	QFN	2.7 to 5.5	3	4	-	-	-	I ² C	5	-	-	Y	-	-
DA9062	QFN	2.8 to 5.5	4	4	-	-	Y	I ² C	5	Y	-	Y	-	-
DA9063	BGA	2.8 to 5.5	6	11	Y	-	Y	I ² C, SPI	16	Y	-	Y	-	-
DA9066	WLCSP	2.5 to 4.4	6	20	Y	-	Y	I ² C	1	Y	-	Y	G, D	Y
DA9068	WLCSP	2.8 to 4.5	8	25	Y	-	Y	I ² C	1	Y	-	Y	-	-

Sub-PMIC Product Portfolio

Product	Package	Input Voltage (V)	Regulators	Interface	GPIOs
DA9121	WLCSP	2.5 to 5.5	One dual-phase buck (10A)	FC	5
DA9122	WLCSP	2.5 to 5.5	Two single-phase bucks (5A each)	FC	5
DA9211	WLCSP	2.8 to 5.5	One quad-phase buck (12A)	FC, SPI	5
DA9212	WLCSP	2.8 to 5.5	Two dual-phase bucks (6A each)	FC, SPI	5
DA9213	WLCSP	2.8 to 5.5	One quad-phase buck (20A)	FC, SPI	5
DA9214	WLCSP	2.8 to 5.5	Two dual-phase bucks (10A each)	FC, SPI	5
DA9215	WLCSP	2.8 to 5.5	One triple-phase buck (15 A) and one single-phase buck (5A)	FC, SPI	5
DA9217	WLCSP	2.5 to 5.5	One dual-phase buck (6A)	FC	5
DA9220	WLCSP	2.5 to 5.5	Two single-phase bucks (3A each)	FC	5
DA9230	WLCSP	2.5 to 5.5	One 300mA with low Iq	FC	1
DA9231	WLCSP	2.5 to 5.5	One 300mA buck plus one 100mA LDO / Load Switch	FC	1

Easy development with SmartCanvas™ and Power Commander user interface

The Dialog SmartCanvas and Power Commander software equips hardware and software developers with a powerful graphical interface for viewing and controlling Dialog system PMICs, sub-PMICs, chargers, and DC/DC converters. The benefits include:

- Any start-up sequence can be quickly tested in real-time
- Easy setup of the fully-programmable sequencer for bucks, LDOs, GPIOs, and system control signals
- Configuration of up to three power domains which are selectable via the sequencer, by GPIOs, or by software
- Fast debugging using the I²C interface for full visibility of the PMIC status

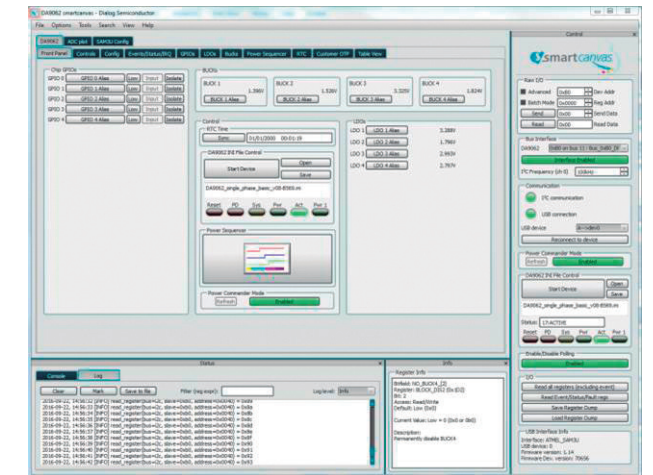

Complete solutions for smartphone devices:

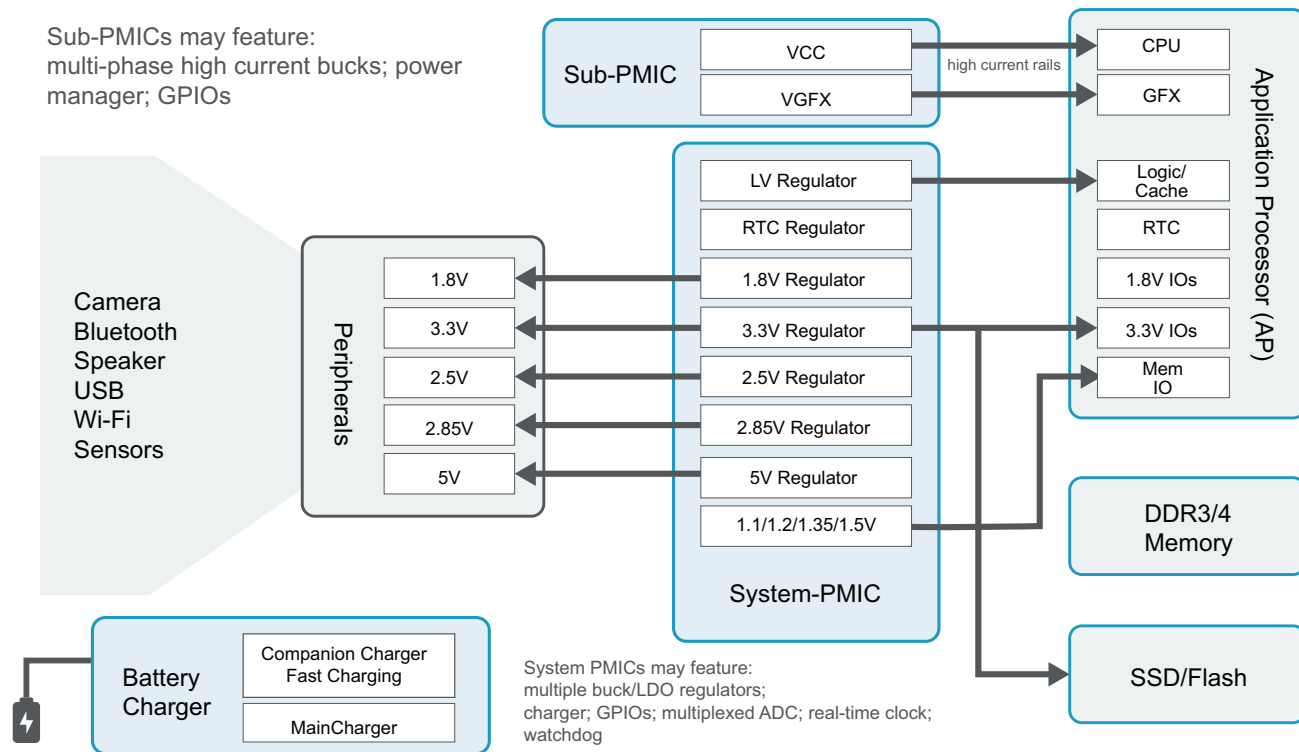

Switched Capacitor DC-DC Converters

Dialog Semiconductor is first in the industry to launch DA9313, an ultra-efficient Buck Converter that does not require the use of inductors. This differentiated technology is leading the way in optimizing next-generation mobile devices.

This family of devices - also referred to as Switched Cap Dividers - can offer up to 98% efficiency at high power levels. The combination of "almost loss-less" conversion and high power density make it ideally suited to power the emerging design trends in Smartphones. Major benefits of this unique technology include direct charging of single cell Lithium Ion batteries - enabling usage of standard 3A low-cost USB cables to deliver up to 6A of charging current, 75% reduced routing losses and more than 50% reduction in PCB board area - all within a package height of less than 1mm.

The DA9313 - Dialog's 1st-Gen offering - can provide up to 10A of current in a 10mm² offering with an extremely flat efficiency curve at a peak efficiency of 98.2% over a wide range of output current loads. It can also operate in a Master-Slave configuration to deliver up to 20A. The DA9313 also offers enable and power-good functions and can be configured to operate in a fixed-frequency mode.

The next-generation of this unique technology is in development and will be introduced to key customers during the 1st half of 2019 and to the broader market in late 2019.

Product	Input Voltage	Output Voltage	Current	Interface	Package
DA9313	5-105V	$V_{out} = \frac{1}{2} V_{in}$	10A	I2C	43 ball WLCSF
			(20A in Master-Slave)		

Eff Curve

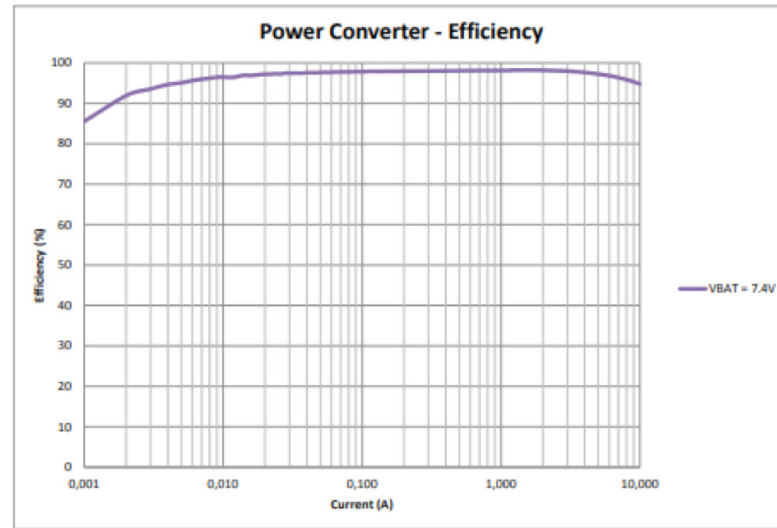

Smartphone charging ICs

Dialog offers a high-efficiency companion charger solution for rapid charging delivering up to 2.5 A charging current, and direct charging solutions that can deliver up to 6 A charging current to the battery using a standard 3 Amp USB cable. Dialog's highly efficient inductor-less switched capacitor DC/DC converter enables 1S mobile devices to migrate to 2S battery configuration without any changes in the regulated voltage rails.

The DA9318 is a high-voltage inductor-less current doubler powering up to 44 W, with integrated protection features and incredible power efficiency of up to 98%, and has an input voltage range of 5.5 V to 10.5 V.

The DA9155M is a 2.5 A companion charger with 92% peak efficiency for 1S battery applications, and has an input voltage range of 4.3 V to 13.5 V for all rapid charging technologies.

Product	Package	Input Voltage (V)	Output Voltage (V)	Maximum Output Current (A)	Interface	Over-temperature Protection	Over-current Protection	Input Voltage Protection	Battery voltage Protection	Input-to-output Voltage Protection	Safety Timer	Watchdog	Current Sensing	Travel Adapter Detection	ADC
DA9318	WLCSP	5.5 to 10.5	$V_{IN}/2$	L(8), M(10)	FC	Y	Y	Y	Y	Y	Y	Y	Y	Y	8-bit
DA9155M	WLCSP	4.3 to 13.5	6	2.5	FC	Y	Y	Y	Y	Y	Y	-	-	-	-

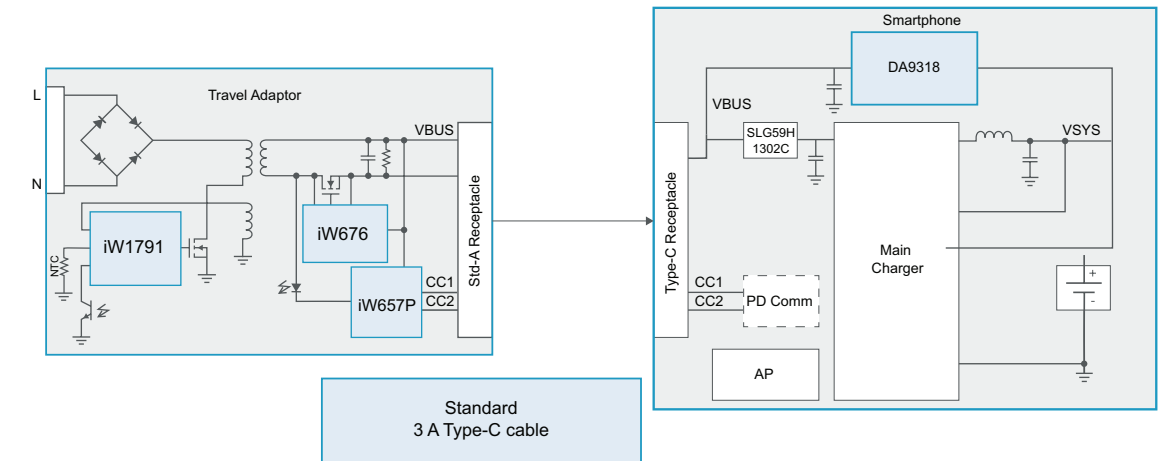



Highly integrated,
configurable
and scalable
solutions that
are compact and
efficient to fully
meet the power
management
needs of today's
smartphones.

AC/DC RapidCharge™ controller solutions

As the leader in AC/DC RapidCharge solutions, Dialog supports more fast-charging protocols than any other supplier, including USB Power Delivery 3.0 (USB PD 3.0); Qualcomm® Quick Charge™ 4+, 3.0 and 2.0 technologies; Samsung Adaptive Fast Charging (AFC); direct charge; and other proprietary OEM protocols.

- USB Power Delivery 3.0
- Qualcomm® Quick Charge™ 4+
- Qualcomm® Quick Charge™ 3.0
- Qualcomm® Quick Charge™ 2.0
- Samsung Adaptive Fast Charging
- Direct Charge
- Other Proprietary OEM Protocols

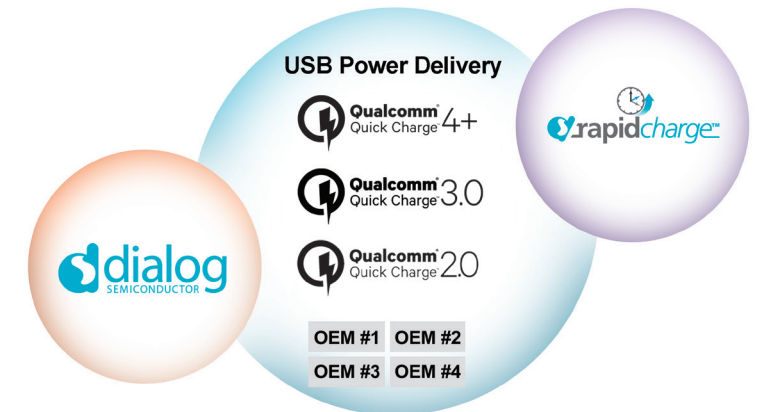

Qualcomm® Quick Charge™ is a trademark of Qualcomm® Technologies Inc.

iW662+iW1796 – low BOM cost 27W Qualcomm® Quick Charge™ 3.0 adapter solution

- iW662 secondary-side synchronous rectifier and RapidCharge™ interface controller in one IC
- iW1796 PrimAccurate™ primary-side controller
No start-up DFET
- iW662 and iW1796 use Dialog's XM-Comm communication technology
Eliminates need for optocoupler
- High power density for small form-factor up to 27W
- Low no-load power consumption < 20mW with fast dynamic load response
- Double-layer cable protection
D+/D- over-voltage protection (iW662)
Advanced fault control technology addresses soft shorts in cables and connectors (iW1796)
- Small, SOT23-6 package (iW1796)
- Optional support for Qualcomm® Quick Charge™ 2.0 and other RapidCharge™ protocols

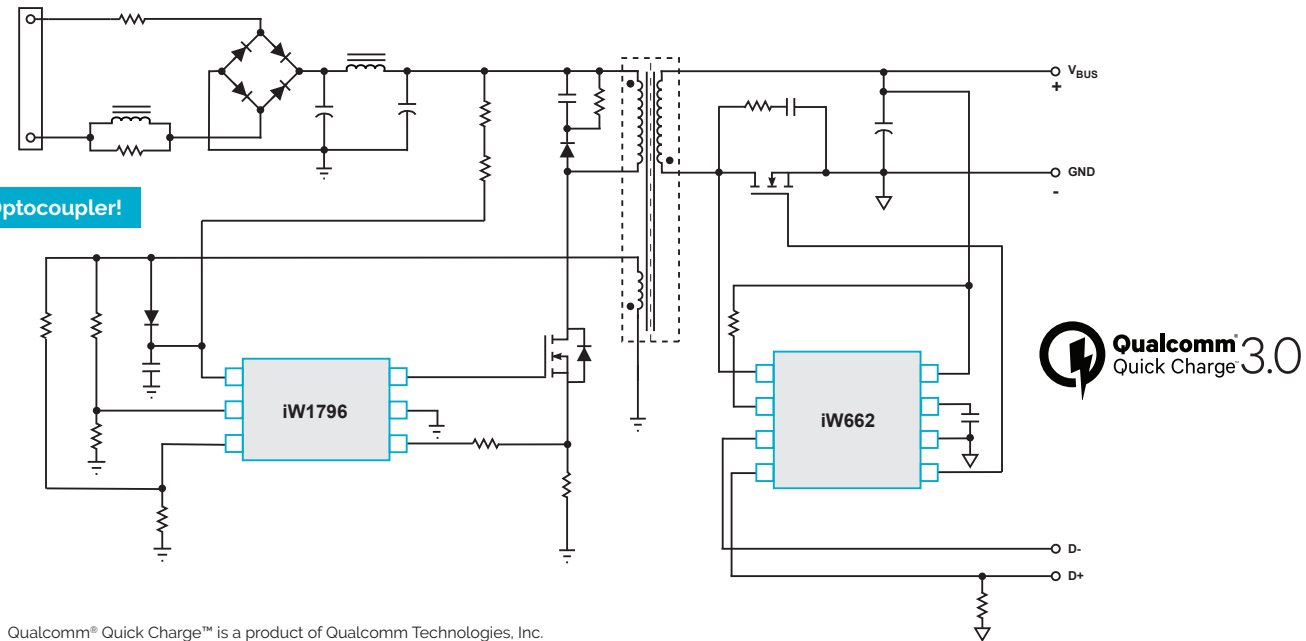

Qualcomm® Quick Charge™ is a product of Qualcomm Technologies, Inc.

iW662+iW1798 – high-power 45W Qualcomm® Quick Charge™ 3.0 adapter solution

- iW662 secondary-side synchronous rectifier and RapidCharge™ interface controller in one IC
- iW1798 PrimAccurate™ primary-side controller
No start-up DFET
- iW662 and iW1798 use Dialog's XM-Comm Communication technology
Eliminates need for optocoupler
- High power density for small form-factor up to 45W
- Low no-load power consumption < 20mW with fast dynamic load response
- Double-layer cable protection
D+/D- over-voltage protection (iW662)
Advanced fault control technology addresses soft shorts in cables and connectors (iW1798)
- Optional support for Qualcomm® Quick Charge™ 2.0 and other RapidCharge™ protocols

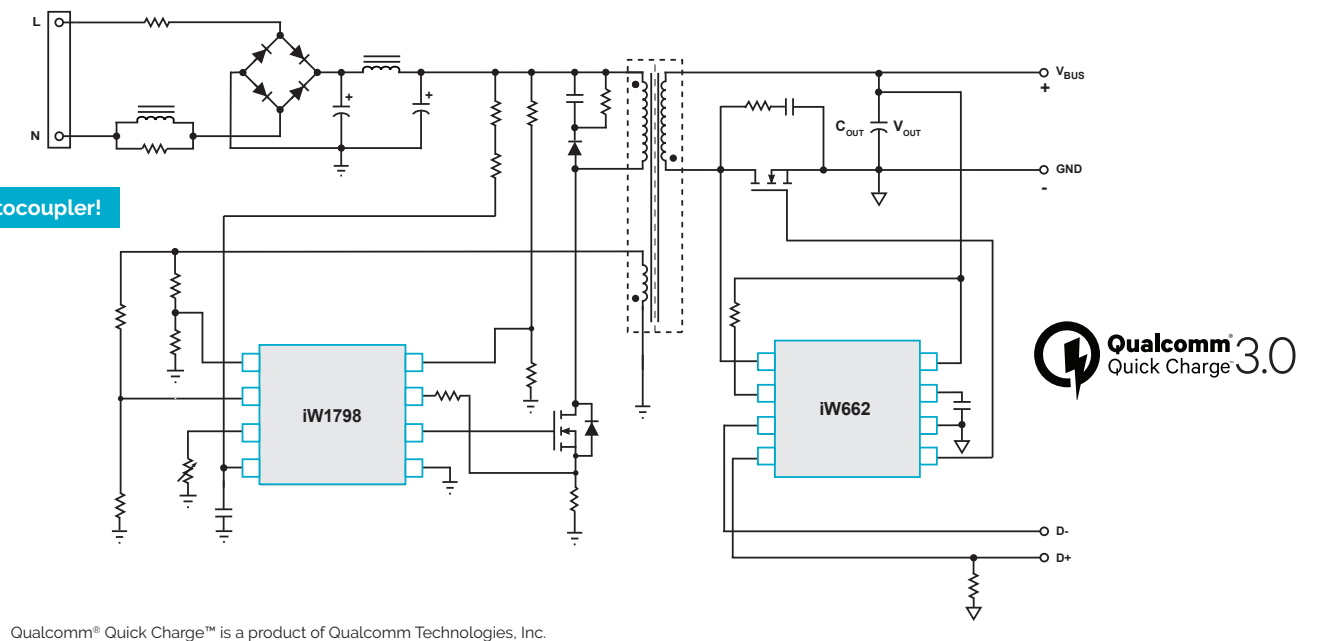

Qualcomm® Quick Charge™ is a product of Qualcomm Technologies, Inc.

iW657P+iW1799+iW676 – complete system solution for USB Power Delivery 3.0 travel adapters

- USB-IF PD certified (USB PD 3.0 + PPS)
- Compatible with USB Type-C™ Rev. 1.2
- Secondary-side NMOS V_{BUS} switch lowers system cost
- V_{CONN} support
- Low no-load power consumption < 20mW with fast DLR (dynamic load response)
- Optional V_{IN} OVP or X-cap discharge (iW1799)
- High power density for small form-factor up to 45W

- Robust protection features**
 - Over-voltage protection
 - Over-current protection
 - Output short protection
 - Over-temperature protection
 - Active discharge
 - V_{BUS} switch output short protection
 - AC unplug detection for direct charge (iW1799)
 - D+/D-/CC1/CC2 over-voltage protection (iW657P)
 - Integrated current sense (iW657P)
- Optional support for:**
 - Qualcomm® Quick Charge™ 4+
 - Direct Charge
 - Other RapidCharge™ protocols

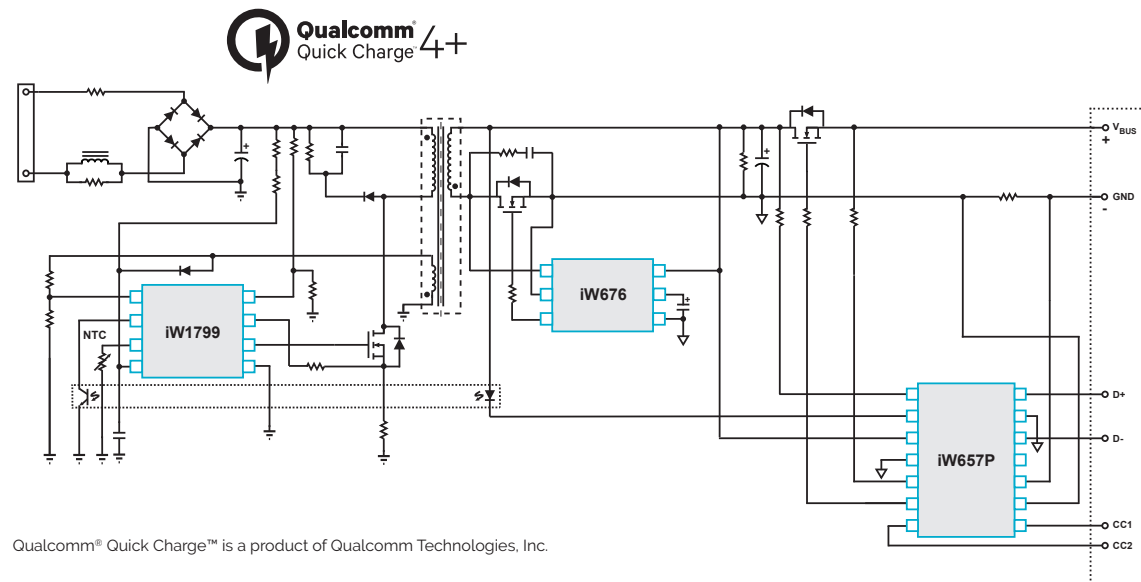

Qualcomm® Quick Charge™ is a product of Qualcomm Technologies, Inc.

AC/DC RapidCharge™ adapter solutions

Primary Side	Secondary Side	RapidCharge Protocol			Direct Charge	USB Power Delivery 3.0	Output Power (max.)	Output Voltage	Secondary-to-Primary Communication		Additional Features
		2.0	3.0	4+					DLNK ⁽¹⁾	XM-Comm ⁽²⁾	
iW1782	iW636	✓	✓			36 W	3.6 V – 12 V	✓		<ul style="list-style-type: none"> D+/D- over-voltage protection (iW636) iW673 SR for 90% efficiency 	
iW1790/ iW1796	iW660/ iW662	✓	✓			27 W	3 V – 12 V		✓	<ul style="list-style-type: none"> D+/D- over-voltage protection (iW660, iW662) Integrated SR for lower BOM and 90% efficiency (iW660, iW662) 	
iW1791/ iW1797	iW656P/ iW657P	✓	✓	✓	✓	27 W	3.3 V – 21 V	✓		<ul style="list-style-type: none"> USB-IF PD certified (USB PD 3.0 + PPS) D+/D-/CC1/CC2 over-voltage protection (iW656P, iW657P) Integrated current sense (iW657P) iW676 SR for > 90% efficiency 	
iW1798	iW660/ iW662	✓	✓			45W	3.6V - 12V		✓	<ul style="list-style-type: none"> D+/D- over-voltage protection (iW660, iW662) Integrated SR for lower BOM and 90% efficiency (iW660, iW662) 	
iW1799	iW656P/ iW657P	✓	✓	✓	✓	45W	3.3V - 21V	✓		<ul style="list-style-type: none"> USB-IF PD certified (USB PD 3.0 + PPS) D+/D-/CC1/CC2 over-voltage protection (iW656P, iW657P) Integrated current sense (iW657P) iW676 SR for > 90% efficiency 	

(1) DLNK is Dialog's digital communication from secondary to primary side via an optocoupler.

(2) XM-Comm is Dialog's proprietary digital communication via the main power transformer that eliminates the need for an optocoupler.

Qualcomm® Quick Charge™ is a product of Qualcomm Technologies, Inc.



iW1602+iW676 AC/DC high power density travel adapter solution

Dialog's iW1602+iW676 chipset offers an unmatched combination of high efficiency, low standby power and fast dynamic load response DLR⁽¹⁾ enabling smartphone manufacturers to pack more power (higher power density) into smaller travel adapters without incurring thermal issues.

🔌 iW1602 primary-side controller

- PrimAccurate™ primary-side current sensing eliminates secondary-side sense resistor
- Configurable light load operation mode optimizes for low no-load power consumption and fast DLR
- Up to 30 W output

🔌 iW676 secondary-side active voltage position (AVP) controller

- Built-in synchronous rectifier
- Enables < 30 mW no-load power consumption and fast DLR

🔌 Low BOM cost

- 80 mV ripple with single 470 μF output cap
- Low cost slow diodes
- SOT23 package

(1) DLR: Dynamic Load Response - defined as V_{out} voltage deviation for load step from low to high output current.

🔌 Ideal for compact, high power density 5 V, 2 A 10 W smartphone adapters/chargers

🔌 Double-layer cable protection

- Dedicated pins for external over-voltage protection with latch (iW1602)
- SmartDefender™ advanced hiccup technology (iW1602)

🔌 Robust protection features

- Output short circuit protection
- Output over-voltage protection
- Output over-current protection
- Over-temperature protection

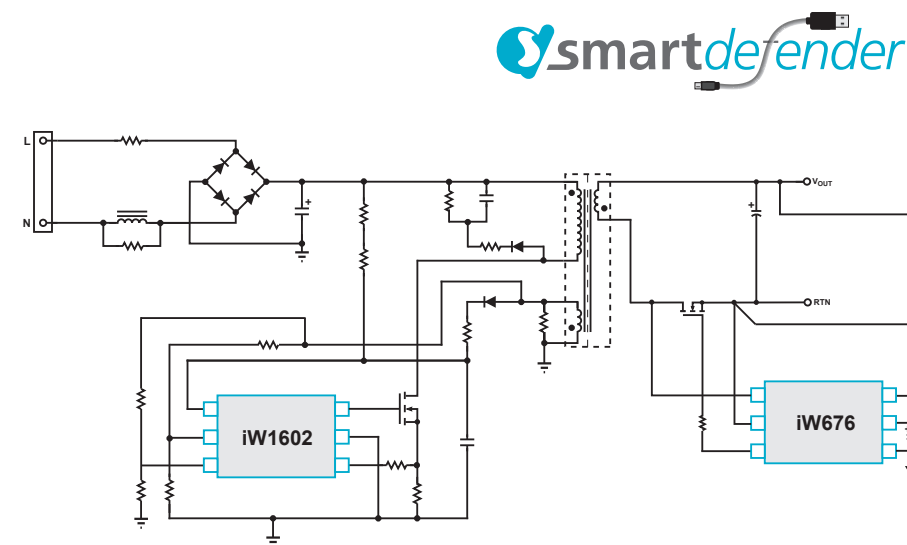

AC/DC secondary-side ICs

Product	Voltage Position Controller	Synchronous Rectifier Controller	Quiescent Current	Features	Package
iW673		<input checked="" type="checkbox"/>	< 450 μ A at no load		SOT23-6
iW676	<input checked="" type="checkbox"/>	<input checked="" type="checkbox"/>	< 650 μ A at no load	25 V Output, optimized for lowest BOM cost in applications up to 12 V Optimized for direct charging applications down to 3 V	SOT23-6
iW873		<input checked="" type="checkbox"/>	< 450 μ A at no load	Integrated 60 V Power MOSFET	SO-8

Digital synchronous rectifiers replace Schottky diode for higher efficiency, ultra-compact power adapters – iW673, iW676

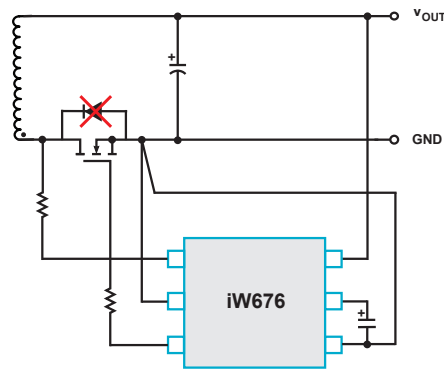

Features and Benefits

- Eliminates parallel Schottky diode for lower BOM cost
- Added benefits of iW676
 - 25 V output, optimized for lowest BOM cost in applications up to 12 V
 - Optimized for direct charging applications down to 3 V
 - Incorporates AVP (Active Voltage Positioning) for fast dynamic load response



Haptics

Haptics technology recreates the sense of touch to the user by applying forces and vibrations in the form of touch feedback in displays, touch surfaces and buttons.

The DA728x - High definition, low power and flexible:

The DA728x family of High-Definition (HD) Haptic Drivers, combine custom drive sequences, on- and off resonance, at up to 1kHz. The device can drive both ERM and LRA (narrow and wideband) actuators and track resonance up to 300Hz to drive the most complex click/vibration touch effects in a wide range of applications.

Saving power when idle:

As haptic drivers spend the majority of their time in standby/idle mode, the DA728x family was designed to utilize very low idle current consumption (360nA) to maximize battery life.

The DA7282 has an additional standby mode where current consumption drops to 5nA, making it an ideal driver for systems where the highest priority is current consumption when not in use.

The DA728x family combines very low idle current consumption with low-latency trigger inputs to minimize system power consumption. Integrated trigger inputs allow haptic operation without waking the application processor, and latency times at sub-1ms give real switch behavior - 10x better than any other solution available today.

Simplifying usage in touchscreen and capacitive touch systems:

Product	Market Focus	Control Method	# of input trigger pins	Lowest power mode	I ² C Addresses
DA7280	General Market	I ² C, PWM, GPI	3	360nA Idle	1
DA7281	Multi-LRA Systems	I ² C, PWM, GPI	1	360nA Idle	4
DA7282	Wearables	I ² C, PWM, GPI	3	5nA Standby	1

DA728x Family Overview

- Wideband LRA driver: 25Hz to 1kHz with resonant mode Frequency tracking support up to 300Hz**
 Drives LRAs off-resonance for custom effects, or dual resonant systems for two-dimensional vibration
- Up to 500mA output current**
 Drive large or small LRAs and ERMs for the best haptic experience
- 360nA idle power mode with full I²C control and memory retention**
 Ultra-low power consumption means longer battery life
 Only 0.75ms latency when responding from ultra-low idle power state
- On-the-fly diagnostics**
 Detect issues with the LRA/ERM Automatically and generate interrupts
- Three methods of drive for ease of use**
 I²C, PWM and General Purpose Inputs (GPIs)
- 5nA standby mode enabled in the DA7282**

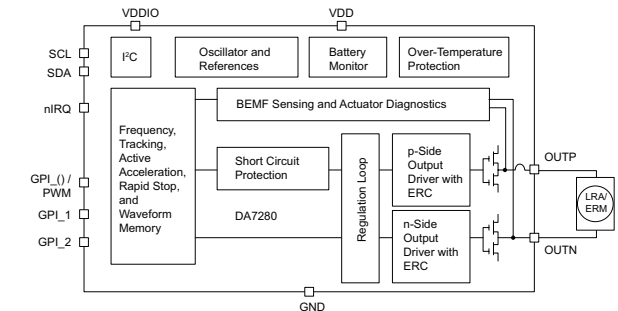
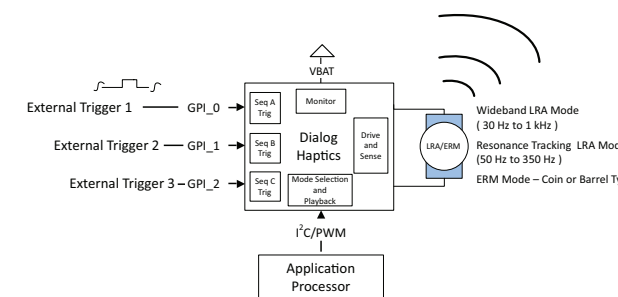

Dialog Semiconductor Worldwide Sales Offices -



www.dialog-semiconductor.com



info@diasemi.com

United Kingdom

 **+44 1793 757 700**

The Netherlands

 **+31 73 640 8822**

Japan

 **+81 3 5769 5100**

Hong Kong

 **+852 3769 5200**

China (Shenzhen)

 **+86 755 2981 3669**

Germany

 **+49 7021 8050**

North America

 **+1 408 845 8500**

Taiwan

 **+886 2 80718888**

Korea

 **+82 2 3469 8200**

China (Shanghai)

 **+86 21 5424 9058**

This publication is issued to provide outline information only, which unless agreed by Dialog Semiconductor may not be used, applied, or reproduced for any purpose or be regarded as a representation relating to products. All use of Dialog Semiconductor products, software and applications referred to in this document are subject to Dialog Semiconductor's Standard Terms and Conditions of Sale, available on the company website (www.dialog-semiconductor.com) unless otherwise stated.

Dialog and the Dialog logo are trademarks of Dialog Semiconductor plc or its subsidiaries. All other product or service names are the property of their respective owners. © Dialog Semiconductor 2020. All rights reserved.