

Description

The ICS251 is a low cost, single-output, field programmable clock synthesizer. The ICS251 can generate an output frequency from 314kHz to 200MHz and may employ Spread Spectrum techniques to reduce system electro-magnetic interference (EMI).

Using IDT's VersaClock software to configure the PLL and output, the ICS251 contains a One-Time Programmable (OTP) ROM to allow field programmability. Programming features include 4 selectable configuration registers.

The device employs Phase-Locked Loop (PLL) techniques to run from a standard fundamental mode, inexpensive crystal, or clock. It can replace multiple crystals and oscillators, saving board space and cost.

The device also has a power-down feature that tri-states the clock outputs and turns off the PLLs when the PDTS pin is taken low.

The ICS251 is also available in factory programmed custom versions for high-volume applications.

Features

- 8-pin SOIC package
- Four addressable registers
- Input crystal frequency of 5 to 27MHz
- Clock input frequency of 3 to 150MHz
- Output clock frequencies up to 200MHz
- Configurable spread spectrum modulation
- Operating voltage of 3.3V
- Replaces multiple crystals and oscillators
- Controllable output drive levels
- Advanced, low-power CMOS process
- RoHS compliant packaging

Block Diagram

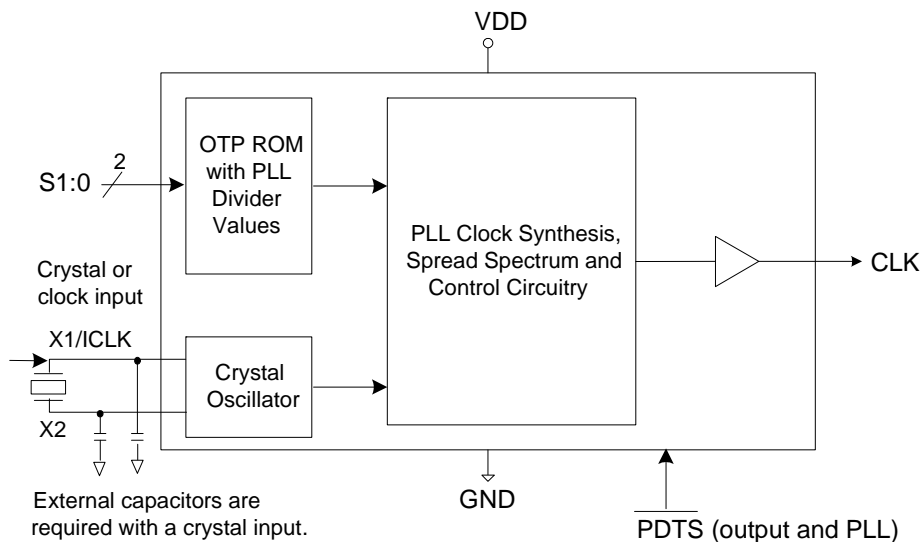

Pin Assignment

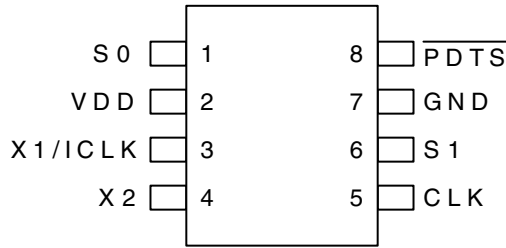

8-pin (150 mil) SOIC

Output Clock Selection Table

S1	S0	CLK (MHz)	Spread Percentage
0	0	User Configurable	User Configurable
0	1	User Configurable	User Configurable
1	0	User Configurable	User Configurable
1	1	User Configurable	User Configurable

Pin Descriptions

Pin Number	Pin Name	Pin Type	Pin Description
1	S0	Input	Select pin 0 for frequency selection on CLK. Internal pull-up resistor.
2	VDD	Power	Connect to +3.3 V.
3	X1/ICLK	XI	Connect this pin to a crystal or external clock input.
4	X2	XO	Connect this pin to a crystal, or float for clock input.
5	CLK	Output	Clock output. Weak internal pull-down when tri-state.
6	S1	Input	Select pin 1 for frequency selection on CLK. Internal pull-up resistor.
7	GND	Power	Connect this to ground.
8	$\overline{\text{P D T S}}$	Input	Powers down entire chip. Tri-states CLK outputs when low. No internal pull-up resistor. The pin must be tied either directly or through the external resistor to VDD or GND. External resistor value must be less than 15kOhm.

External Components

The ICS251 requires a minimum number of external components for proper operation.

Series Termination Resistor

Clock output traces over one inch should use series termination. To series terminate a 50Ω trace (a commonly used trace impedance), place a 33Ω resistor in series with the clock line, as close to the clock output pin as possible. The nominal impedance of the clock output is 20Ω.

Decoupling Capacitor

As with any high-performance mixed-signal IC, the ICS251 must be isolated from system power supply noise to perform optimally.

A decoupling capacitor of 0.01μF must be connected between VDD and the PCB ground plane.

Crystal Load Capacitors

The device crystal connections should include pads for small capacitors from X1 to ground and from X2 to ground. These capacitors are used to adjust the stray capacitance of the board to match the nominally required crystal load

capacitance. Because load capacitance can only be increased in this trimming process, it is important to keep stray capacitance to a minimum by using very short PCB traces (and no vias) between the crystal and device. Crystal capacitors must be connected from each of the pins X1 and X2 to ground.

The value (in pF) of these crystal caps should equal $(C_L - 6\text{pF}) \times 2$. In this equation, C_L = crystal load capacitance in pF. Example: For a crystal with a 16pF load capacitance, each crystal capacitor would be 20pF $[(16-6) \times 2] = 20$.

PCB Layout Recommendations

For optimum device performance and lowest output phase noise, the following guidelines should be observed.

1) The 0.01 μF decoupling capacitor should be mounted on the component side of the board as close to the VDD pin as possible. No vias should be used between the decoupling capacitor and VDD pin. The PCB trace to VDD pin should be kept as short as possible, as should the PCB trace to the ground via. Distance of the ferrite bead and bulk decoupling from the device is less critical.

2) The external crystal should be mounted just next to the device with short traces. The X1 and X2 traces should not be routed next to each other with minimum spaces, instead they should be separated and away from other traces.

3) To minimize EMI, the 33 Ω series termination resistor (if needed) should be placed close to the clock output.

4) An optimum layout is one with all components on the same side of the board, minimizing vias through other signal layers. Other signal traces should be routed away from the ICS251. This includes signal traces just underneath the device, or on layers adjacent to the ground plane layer used by the device.

ICS251 Configuration Capabilities

The architecture of the ICS251 allows the user to easily configure the device to a wide range of output frequencies, for a given input reference frequency.

The frequency multiplier PLL provides a high degree of precision. The M/N values (the multiplier/divide values available to generate the target VCO frequency) can be set within the range of M = 1 to 2048 and N = 1 to 1024.

The ICS251 also provides separate output divide values, from 2 through 20, to allow the two output clock banks to support widely differing frequency values from the same PLL.

Each output frequency can be represented as:

$$\text{OutputFreq} = \frac{\text{REFFreq}}{\text{OutputDivide}} \cdot \frac{M}{N}$$

Output Drive Control

The ICS251 has two output drive settings. Low drive should be selected when outputs are less than 100MHz. High drive should be selected when outputs are greater than 100MHz. (Consult the AC Electrical Characteristics for output rise and fall times for each drive option.)

IDT VersaClock Software

IDT applies years of PLL optimization experience into a user friendly software that accepts the user's target reference clock and output frequencies and generates the lowest jitter, lowest power configuration, with only a press of a button. The user does not need to have prior PLL experience or determine the optimal VCO frequency to support multiple output frequencies.

VersaClock software quickly evaluates accessible VCO frequencies with available output divide values and provides an easy to understand, bar code rating for the target output frequencies. The user may evaluate output accuracy, performance trade-off scenarios in seconds.

Spread Spectrum Modulation

The ICS251 utilizes frequency modulation (FM) to distribute energy over a range of frequencies. By modulating the output clock frequencies, the device effectively lowers energy across a broader range of frequencies; thus, lowering a system's electro-magnetic interference (EMI). The modulation rate is the time from transitioning from a minimum frequency to a maximum frequency and then back to the minimum.

Spread Spectrum Modulation can be applied as either "center spread" or "down spread". During center spread modulation, the deviation from the target frequency is equal in the positive and negative directions. The effective average frequency is equal to the target frequency. In applications where the clock is driving a component with a maximum frequency rating, down spread should be applied. In this case, the maximum frequency, including modulation, is the target frequency. The effective average frequency is less than the target frequency.

The ICS251 operates in both center spread and down spread modes. For center spread, the frequency can be modulated between $\pm 0.125\%$ to $\pm 2.0\%$. For down spread, the frequency can be modulated between -0.25% to -4.0% .

Both output frequency banks will utilize identical spread spectrum percentage deviations and modulation rates, if a common VCO frequency can be identified.

Spread Spectrum Modulation Rate

The spread spectrum modulation frequency applied to the output clock frequency may occur at a variety of rates. For applications requiring the driving of "down-circuit" PLLs, Zero Delay Buffers, or those adhering to PCI standards, the spread spectrum modulation rate should be set to 30–33kHz. For other applications, a 120kHz modulation option is available.

Absolute Maximum Ratings

Stresses above the ratings listed below can cause permanent damage to the ICS251. These ratings, which are standard values for IDT commercially rated parts, are stress ratings only. Functional operation of the device at these or any other conditions above those indicated in the operational sections of the specifications is not implied. Exposure to absolute maximum rating conditions for extended periods can affect product reliability. Electrical parameters are guaranteed only over the recommended operating temperature range.

Parameter	Condition	Min.	Typ.	Max.	Units
Supply Voltage, VDD	Referenced to GND.	-0.5		4.6	V
Inputs	Referenced to GND.	-0.5		VDD + 0.5	V
Clock Outputs	Referenced to GND.	-0.5		VDD + 0.5	V
Storage Temperature		-65		150	°C
Soldering Temperature	Max 10 seconds.			260	°C
Junction Temperature				125	°C

Recommended Operation Conditions

Parameter	Min.	Typ.	Max.	Units
Ambient Operating Temperature (ICS251M)	0		+70	°C
Ambient Operating Temperature (ICS251MI)	-40		+85	°C
Power Supply Voltage (measured in respect to GND)	+3.15	+3.3	+3.45	V
Power Supply Ramp Time			4	ms

DC Electrical Characteristics

Unless stated otherwise, $V_{DD} = 3.3V \pm 5\%$, ambient temperature -40 to $+85^{\circ}C$

Parameter	Symbol	Conditions	Min.	Typ.	Max.	Units
Operating Voltage	V_{DD}		3.15	3.3	3.45	V
Operating Supply Current Input High Voltage	I_{DD}	Configuration dependent - see VersaClock estimates.				mA
		33.3333 MHz output, $\overline{PDT\overline{S}}$ = 1, no load. Note 1.		14		mA
		$\overline{PDT\overline{S}} = 0$.		500		μA
Input High Voltage	V_{IH}	S1:S0.	$V_{DD}/2 + 1$			V
Input Low Voltage	V_{IL}	S1:S0.			0.4	V
Input High Voltage, $\overline{PDT\overline{S}}$	V_{IH}		$V_{DD} - 0.5$			V
Input Low Voltage, $\overline{PDT\overline{S}}$	V_{IL}				0.4	V
Input High Voltage	V_{IH}	ICLK.	$V_{DD}/2 + 1$			V
Input Low Voltage	V_{IL}	ICLK.			$V_{DD}/2 - 1$	V
Output High Voltage (CMOS High)	V_{OH}	$I_{OH} = -4mA$.	$V_{DD} - 0.4$			V
Output High Voltage	V_{OH}	$I_{OH} = -8mA$ (Low Drive); $I_{OH} = -12mA$ (High Drive).	2.4 $V_{DD} - 0.4$			V
Output Low Voltage	V_{OL}	$I_{OL} = 8mA$ (Low Drive); $I_{OL} = 12mA$ (High Drive).			0.4	V
Short Circuit Current	I_{OS}			± 70		mA
Nominal Output Impedance	Z_O			20		Ω
Internal Pull-up Resistor	R_{PUP}	S1:S0, $\overline{PDT\overline{S}}$.		190		$k\Omega$
Internal Pull-down Resistor	R_{PD}	CLK output.		120		$k\Omega$
Input Capacitance	C_{IN}	Inputs.		4		pF

Note 1: Example with 25MHz crystal input with output of 33.3MHz, no load, and $V_{DD} = 3.3V$.

AC Electrical Characteristics

Unless stated otherwise, $V_{DD} = 3.3V \pm 5\%$, ambient temperature -40 to $+85^{\circ}C$

Parameter	Symbol	Conditions	Min.	Typ.	Max.	Units
Input Frequency	F_{IN}	Fundamental crystal.	5		27	MHz
		Input clock.	3		150	MHz
Output Frequency			0.314		200	MHz
Output Rise Time	t_{OR}	20% to 80%, Note 1.		1		ns
Output Fall Time	t_{OF}	80% to 20%, Note 1.		1		ns
Duty Cycle		Note 2.	40	49–51	60	%
Power-up Time		PLL lock time from power-up.		4	10	ms
		P \overline{DTS} goes high until stable CLK output, spread spectrum off.		.6	2	ms
		P \overline{DTS} goes high until stable CLK output, spread spectrum on.		4	7	ms
		P \overline{DTS} goes high until spread spectrum is stable, spread spectrum on.		10	50	ms
One Sigma Clock Period Jitter		Configuration dependent.		50		ps
Maximum Absolute Jitter	t_{ja}	Deviation from Mean. Configuration dependent.		± 200		ps

Note 1: Measured with 15pF load.

Note 2: Duty cycle is configuration dependent. Most configurations are minimum 45% and maximum 55%.

Thermal Characteristics

Parameter	Symbol	Conditions	Min.	Typ.	Max.	Units
Thermal Resistance Junction to Ambient	θ_{JA}	Still air.		150		$^{\circ}C/W$
	θ_{JA}	1 m/s air flow.		140		$^{\circ}C/W$
	θ_{JA}	3 m/s air flow.		120		$^{\circ}C/W$
Thermal Resistance Junction to Case	θ_{JC}			40		$^{\circ}C/W$

Marking Diagrams

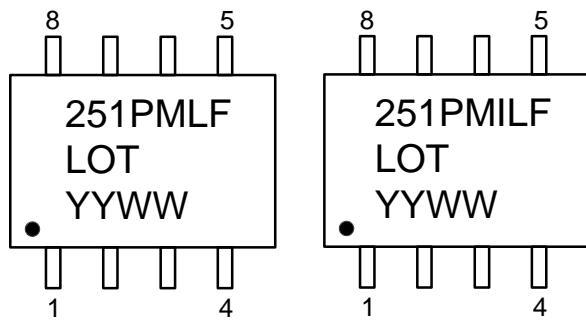

Notes:

1. "LOT" is the lot number.
2. "YYWW" is the last two digits of the year and week that the part was assembled.
3. "I" denotes industrial temp. range (if applicable).
4. "LF" denotes RoHS compliant package.
5. Bottom marking: country of origin.

Package Drawings (DCG8, 8-SOIC, 150 Mil. Body)

REVISIONS			
DATE CREATED	REV	DESCRIPTION	AUTHOR
3/14/17	00	INITIAL RELEASE	J HUA

NOTE: REFER TO DCP FOR OFFICIAL RELEASE DATE

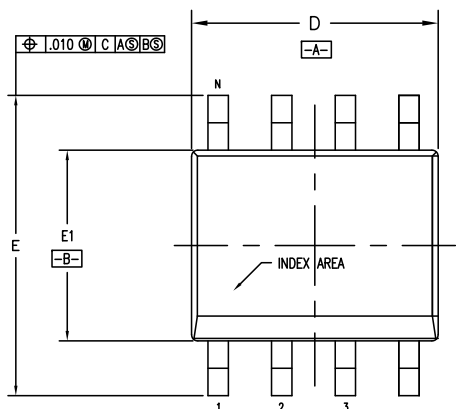

DC/DCG8			
SYMBOL	JEDEC VARIATION		
	AA		
	MIN	NOM	MAX
A	.053	.064	.068
A1	.004	.006	.010
A2	.055	.058	.061
D	.189	.194	.197
E	.230	.236	.244
E1	.150	.155	.157
N	8		

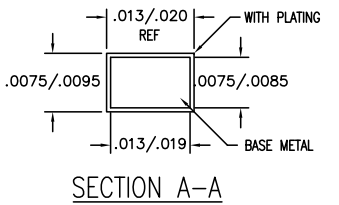
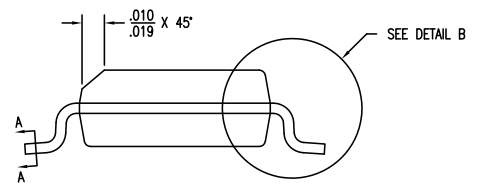
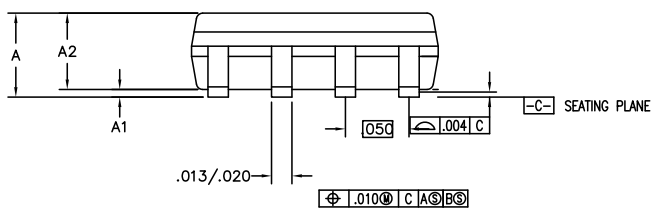
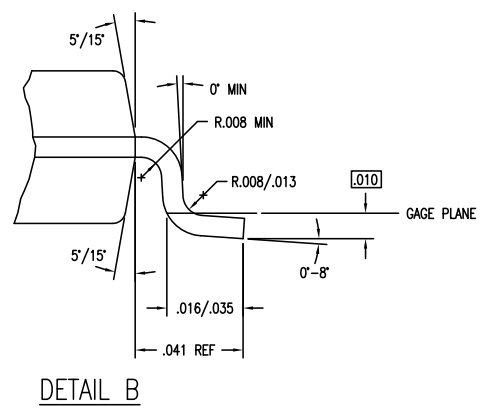

TOLERANCES UNLESS SPECIFIED DECIMAL ANGULAR XX± XXX± XXXX±			6024 SILVERCREEK VALLEY RD SAN JOSE CA 95138 PHONE: (408) 284-8200 FAX: (408) 284-8591
	www.IDT.com		
TITLE DC/DCG8 PACKAGE OUTLINE (DC OR S1 TOPMARK CODE) .150" BODY WIDTH SOIC .050" PITCH			
SIZE	DRAWING No.	REV	
C	PSC-4688	00	
DO NOT SCALE DRAWING			SHEET 1 OF 2

DATE CREATED	REVISIONS		
	REV	DESCRIPTION	AUTHOR
3/14/17	00	INITIAL RELEASE	J HJA

NOTE: REFER TO DCP FOR OFFICIAL RELEASE DATE

LAND PATTERN DIMENSIONS

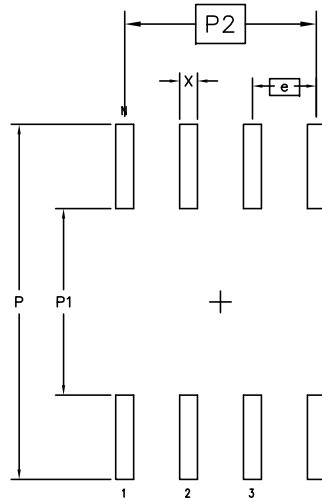

	MIN	MAX
P	.274	.282
P1	.142	.150
P2	.150 BSC	
X	.015	.024
e	.050 BSC	
N	8	

NOTES:

- 1 ALL DIMENSIONING AND TOLERANCING CONFORM TO ANSI Y14.5M-1982
- 2 ALL DIMENSIONS ARE IN INCHES

TOLERANCES UNLESS SPECIFIED DECIMAL ANGULAR XX± ± XXX± ± XXXX± ±	 6024 SILVERCREEK VALLEY RD SAN JOSE CA 95138 PHONE: (408) 284-8200 FAX: (408) 284-8591	
	www.IDT.com	
TITLE DC/DCG8 PACKAGE OUTLINE (DC OR S1 TOPMARK CODE) .150" BODY WIDTH SOIC .050" PITCH		
SIZE	DRAWING No.	REV
C	PSC-4688	00
DO NOT SCALE DRAWING		SHEET 2 OF 2

Ordering Information

Part / Order Number	Marking	Shipping Packaging	Package	Temperature
251PMLF	See page 7	Tubes	8-pin SOIC	0 to +70° C
251PMILF		Tubes	8-pin SOIC	-40 to +85° C
251M-XXLF	251MXXLF	Tubes	8-pin SOIC	0 to +70° C
251MI-XXLF	251MIXXLF	Tubes	8-pin SOIC	-40 to +85° C
251M-XXLFT	251MXXLF	Tape and Reel	8-pin SOIC	0 to +70° C
251MI-XXLFT	251MIXXLF	Tape and Reel	8-pin SOIC	-40 to +85° C

Parts that are ordered with a “LF” suffix to the part number are the Pb-Free configuration and are RoHS compliant.

The 251M-XXLF and 251MI-XXLF are factory programmed versions of the ICS251PMLF and ICS251PMILF. A unique “-XX” suffix is assigned by the factory for each custom configuration, and a separate data sheet is kept on file. For more information on custom part numbers programmed at the factory, please contact your local IDT sales and marketing representative.

Revision History

Date	Description of Change
October 10, 2017	<ol style="list-style-type: none"> 1. Updated marking diagrams. 2. Added legal disclaimer 3. Updated package outline drawings. 4. Updated ordering information.
May 19, 2014	<ol style="list-style-type: none"> 1. Updated Supply Voltage max rating from 7V to 4.6V 2. Updated datasheet with latest version of template.

IMPORTANT NOTICE AND DISCLAIMER

RENESAS ELECTRONICS CORPORATION AND ITS SUBSIDIARIES (“RENESAS”) PROVIDES TECHNICAL SPECIFICATIONS AND RELIABILITY DATA (INCLUDING DATASHEETS), DESIGN RESOURCES (INCLUDING REFERENCE DESIGNS), APPLICATION OR OTHER DESIGN ADVICE, WEB TOOLS, SAFETY INFORMATION, AND OTHER RESOURCES “AS IS” AND WITH ALL FAULTS, AND DISCLAIMS ALL WARRANTIES, EXPRESS OR IMPLIED, INCLUDING, WITHOUT LIMITATION, ANY IMPLIED WARRANTIES OF MERCHANTABILITY, FITNESS FOR A PARTICULAR PURPOSE, OR NON-INFRINGEMENT OF THIRD-PARTY INTELLECTUAL PROPERTY RIGHTS.

These resources are intended for developers who are designing with Renesas products. You are solely responsible for (1) selecting the appropriate products for your application, (2) designing, validating, and testing your application, and (3) ensuring your application meets applicable standards, and any other safety, security, or other requirements. These resources are subject to change without notice. Renesas grants you permission to use these resources only to develop an application that uses Renesas products. Other reproduction or use of these resources is strictly prohibited. No license is granted to any other Renesas intellectual property or to any third-party intellectual property. Renesas disclaims responsibility for, and you will fully indemnify Renesas and its representatives against, any claims, damages, costs, losses, or liabilities arising from your use of these resources. Renesas' products are provided only subject to Renesas' Terms and Conditions of Sale or other applicable terms agreed to in writing. No use of any Renesas resources expands or otherwise alters any applicable warranties or warranty disclaimers for these products.

(Disclaimer Rev.1.01 Jan 2024)

Corporate Headquarters

TOYOSU FORESIA, 3-2-24 Toyosu,
Koto-ku, Tokyo 135-0061, Japan
www.renesas.com

Trademarks

Renesas and the Renesas logo are trademarks of Renesas Electronics Corporation. All trademarks and registered trademarks are the property of their respective owners.

Contact Information

For further information on a product, technology, the most up-to-date version of a document, or your nearest sales office, please visit www.renesas.com/contact-us/.