

Description

The 5X35023 is the latest VersaClock programmable clock generator with an integrated crystal, and is designed for low power, consumer, and high-performance PCI Express applications.

The 5X35023 device is a 3 PLL architecture design, and each PLL is individually programmable allowing for up to 6 unique frequencies outputs. The device has built-in unique features such as Proactive Power Saving (PPS), Performance-Power Balancing (PPB), Overshoot Reduction Technology (ORT) and Extreme Low Power DCO.

An internal OTP memory allows the user to store the configuration in the device, after power up, user can change the register setting through the I²C interface when I²C mode is selected. The device has programmable VCO and PLL source selection to allow power-performance optimization base on the application requirements. The device supports 3 single-ended outputs and two pairs of differential outputs that support LVCMOS, LVPECL, LVDS and LP-HCSL.

Low Power 32.768kHz clock is supported with only less than 2µA current consumption for system RTC reference clock.

Typical Applications

- PCIe Gen1/2/3 clock generator
- Consumer application crystal replacements
- SmartDevice, Handheld, Computing and Consumer applications

Block Diagram

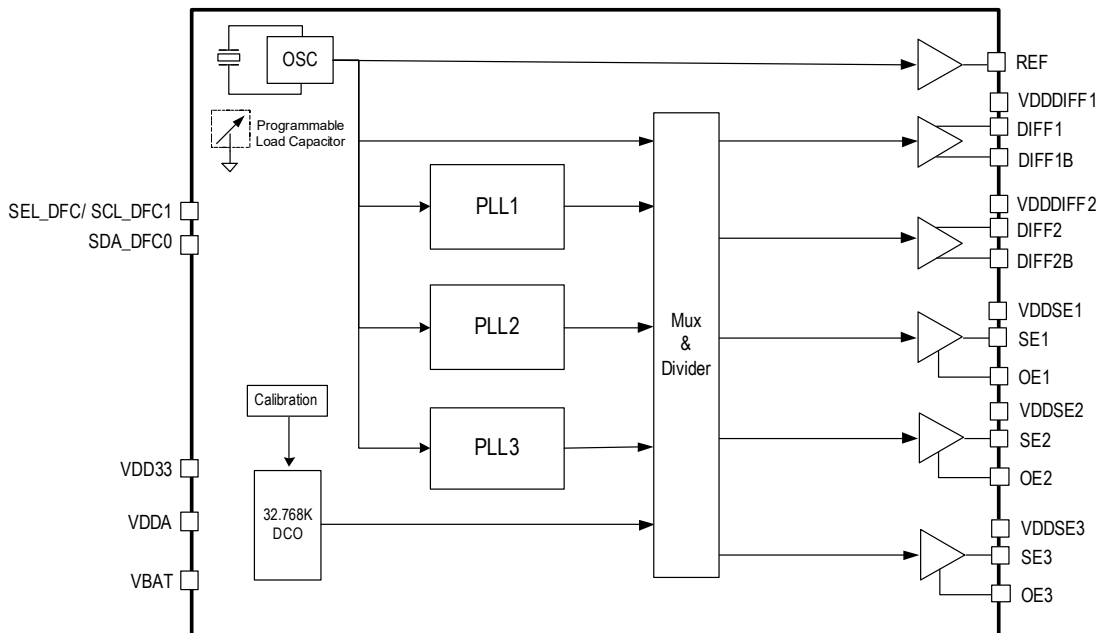

Features

- Configurable OE pin function as OE, PD#, PPS or DFC control function
- Configurable PLL bandwidth; minimizes jitter peaking
- PPS: Proactive Power Saving features save power during the end device power down mode
- PPB: Performance-Power Balancing feature allows minimum power consumption base on required performance
- DFC: Dynamic Frequency Control feature allows up to 4 difference frequencies to switch dynamically
- Spread spectrum clock support to lower system EMI
- I²C interface
- Integrated 25MHz crystal

Key Specifications

- PCIe clocks phase jitter: PCIe Gen3
- Differential clocks < 3 ps rms jitter integer range 12kHz–20MHz

Output Features

- 2 DIFF outputs with configurable LPHSCL, LVDS, LVPECL, LVCMOS output pairs. 1MHz–500MHz (160MHz with LVCMOS mode at DIFF_T)
- 3 LVCMOS outputs: 1MHz–160MHz
- Maximum 8 LVCMOS outputs as REF + 3 × SE + 2 × DIFF_T as LVCMOS
- Low Power 32.768kHz clock supported for all SE1–SE3

Contents

Description	1
Typical Applications	1
Features	1
Key Specifications	1
Output Features	1
Block Diagram	1
Pin Assignments	3
Pin Descriptions	3
Detailed Functional Block Diagram	4
Power Group	5
Output Sources	5
Output Source Selection Register Settings	5
Absolute Maximum Ratings	7
Thermal Characteristics	7
Recommended Operating Conditions	7
Input Capacitance, LVCMOS Output Impedance, and Internal Pull-down	8
Electrical Characteristics	8
Electrical Characteristics – VDDDIFF	9
Electrical Characteristics – VDDSE	12
AC Electrical Characteristics	14
Spread Spectrum Generation Specifications	15
Glossary of Features	15
Device Features and Functions	16
DFC–Dynamic Frequency Control	16
DFC Function Programming	17
PPS–Proactive Power Saving Function	17
PPS Function Programming	18
Timer Function Description	18
OE Pin Function	18
Spread Spectrum	20
VBAT	21
ORT–VCO Overshoot Reduction Technology	21
PLL Features and Descriptions	21
Output Clock Test Conditions	22
I2C Bus Characteristics	23
General I2C Mode Operations	24
Package Outline Drawings	38
Marking Diagrams	38
Ordering Information	38
Revision History	39

Pin Assignments

Figure 1. Pin Assignments for 4 x 4 mm 24-QFN Package – Top View

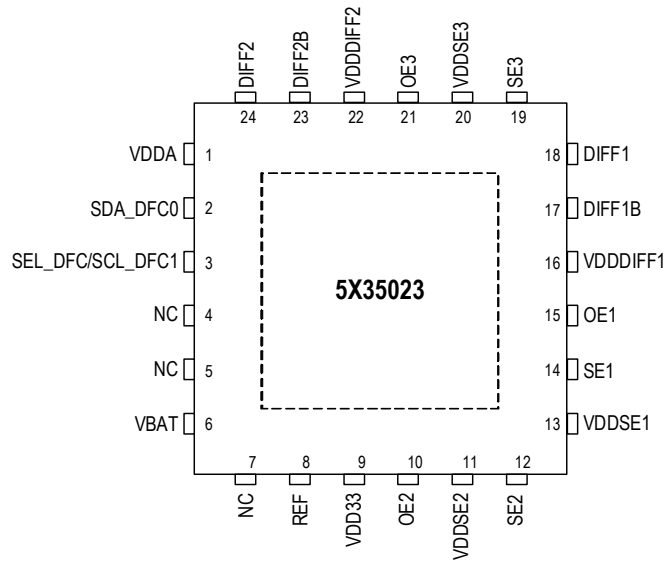

Pin Descriptions

Table 1. Pin Descriptions

Number	Name	Type	Description
1	VDDA	Power	V_{DD} 3.3V.
2	SDA_DFC0	I/O	I ² C DATA pin, the pin can be DFC0 function by pin3 SEL_DFC power on latch status.
3	SEL_DFC/ SCL_DFC1	Input	I ² C clock pin, SEL_DFC is a latch input pin during the power up; High on power on: I ² C mode as SCLK function; Low on power on: pin3 SCL and pin2 SDA as DFC function control pins.
4	NC	—	No connect.
5	NC	—	No connect.
6	VBAT	Power	Power supply pin for 32.768kHz DCO; usually connect to coin cell battery, 3.0V–3.3V.
7	NC	—	No connect.
8	REF	Output	3.3V reference clock output.
9	VDD33	Power	V_{DD} 3.3V.
10	OE2	Input	Output enable control 2, multi-function pin. Refer to OE function table.
11	VDDSE2	Power	Output power supply. Connect to 1.8V to 3.3V. Sets output voltage levels for SE2.
12	SE2	Output	Output clock SE2.
13	VDDSE1	Power	Output power supply. Connect to 1.8V to 3.3V. Sets output voltage levels for SE1.
14	SE1	Output	Output clock SE1.
15	OE1	Input	OE1 function selected from OTP pre-program register bits. OE1 pull to 6.5V when burn OTP registers. Refer to OE function table for details.
16	VDDDIFF1	Power	Output power supply. Connect to 2.5V to 3.3V. Sets output voltage levels for DIFF1.
17	DIFF1B	Output	Differential clock output 1_Complement, can be OTP pre-programmed to LVCMOS/LP-HCSL/LVDS/LVPECL output type.

Table 1. Pin Descriptions (Cont.)

Number	Name	Type	Description
18	DIFF1	Output	Differential clock output 1_True, can be OTP pre-programmed to LVCMOS/LP-HCSL/LVDS/LVPECL output type.
19	SE3	Output	Output clock SE3.
20	VDDSE3	Power	Output power supply. Connect to 1.8V to 3.3V. Sets output voltage levels for SE3.
21	OE3	Input	Output enable control 3, multi-function pin. Refer to OE function table.
22	VDDDIFF2	Power	Output power supply. Connect to 2.5V to 3.3V. Sets output voltage levels for DIFF2.
23	DIFF2B	Output	Differential clock output 2_Complement, can be OTP pre-programmed to LVCMOS/LP-HCSL/LVDS/LVPECL output type.
24	DIFF2	Output	Differential clock output 2_True, can be OTP pre-programmed to LVCMOS/LP-HCSL/LVDS/LVPECL output type.
	EPAD	Power	Connect to ground pad.

Detailed Functional Block Diagram

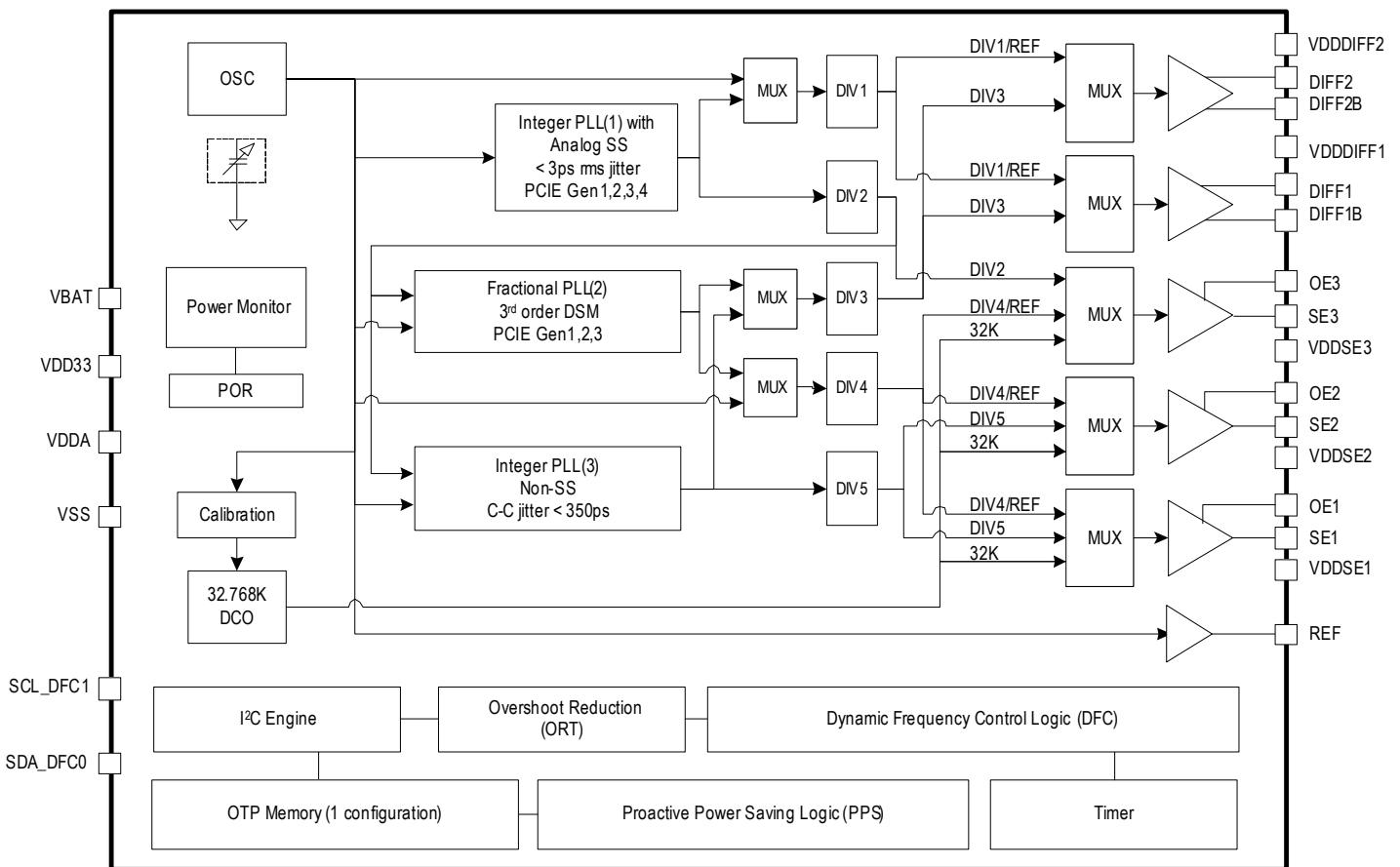

Power Group

Table 2. Power Group

Power Supply	SE	DIFF	DIV	MUX	PLL	DCO	REF	Crystal
VDDSE1	SE1 ¹							
VDDSE2	SE2 ¹							
VDDSE3	SE3 ¹							
VDDDIFF1		DIFF1	DIV3/4	MUXPLL2	PLL2			
VDDDIFF2		DIFF2	DIV1	MUXPLL1				
VDD33			DIV5		PLL3	DCO	REF	Xtal
VBAT ²						DCO		Xtal
VDDA			DIV2		PLL1			

¹ V_{DDSEx} for non-32kHz outputs should be OFF when V_{DDA}/V_{DD33} is turned OFF; V_{BAT} mode only supports 32.768kHz outputs from SE1–3.

² All V_{DD} pins need to have power present even if outputs are not used.

Output Sources

Table 3. Output Sources

Source	Outputs					
	REF	SE1	SE2	SE3	DIFF1	DIFF2
Crystal REF	Crystal REF	Crystal REF	Crystal REF	Crystal REF		
32.768kHz		32.768kHz	32.768kHz	32.768kHz		
PLL1				PLL1	PLL1	PLL1
PLL2		PLL2	PLL2	PLL2	PLL2	PLL2
PLL3		PLL3	PLL3		PLL3	PLL3

Output Source Selection Register Settings

Table 4. SE1 Output Source Register Settings

SE1	B36<4>	B36<3>	B31<1>	B29<3>
From 32K	0	1	0	0
From PLL3 + Divider 5	1	0	0	0
From PLL2 + Divider 4	1	1	1	0
From REF + Divider 4	1	1	0	1

Table 5. SE2 Output Source Register Settings

SE2	B31<7>	B31<6>	B36<0>	B31<1>	B29<3>
From 32K	0	0	0	0	0
From PLL3 + Divider 5	1	0	0	0	0
From PLL2 + Divider 4	1	1	1	1	0
From REF + Divider 4	1	1	1	0	1

Table 6. SE3 Output Source Register Settings

SE3	B33<7>	B33<6>	B7<5>	B29<3>	B36<1>	B31<1>
From 32K	0	0	0	0	0	0
From PLL1 + Divider 2	1	0	1	0	0	0
From PLL2 + Divider 4	1	1	0	0	1	1
From REF + Divider 4	1	1	0	1	1	0

Table 7. DIFF1 Output Source Register Settings

DIFF1	B34<7>	B0<3>
From PLL1 + Divider 1	0	0
From PLL2/3 + Divider 3	1	0
From REF + Divider 1	0	1

Table 8. DIFF2 Output Source Register Settings

DIFF2	B35<7>	B0<3>
From PLL1 + Divider 1	0	0
From PLL2/3 + Divider 3	1	0
From REF + Divider 1	0	1

Absolute Maximum Ratings

The absolute maximum ratings are stress ratings only. Stresses greater than those listed below can cause permanent damage to the device. Functional operation of the 5X35023 at absolute maximum ratings is not implied. Exposure to absolute maximum rating conditions may affect device reliability.

Table 9. Absolute Maximum Ratings

Parameter	Rating
Supply Voltage, V_{DDA} , V_{DD33} , V_{DDSE} , V_{DDDIFF}	3.465V
Supply Voltage, V_{BAT}	3.465V
Inputs	-0.5V to V_{DD33}/V_{DDSEx}
Outputs, V_{DDSEx} (LVCMOS)	-0.5V to $V_{DDSEx}/V_{DDDIFF} + 0.5V$
Outputs, IO (SDA)	10mA
Storage Temperature, T_{STG}	-65°C to 150°C
ESD Human Body Model	2000V
Junction Temperature	125°C

Thermal Characteristics

Table 10. Thermal Characteristics

Symbol	Parameter	Value	Unit
θ_{JA}	Theta J_A . Junction to air thermal impedance (0mps).	32.4	°C/W
θ_{JB}	Theta J_B . Junction to board thermal impedance (0mps).	2.8	°C/W
θ_{JC}	Theta J_C . Junction to case thermal impedance (0mps).	44.7	°C/W

Recommended Operating Conditions

Table 11. Recommended Operating Conditions

Symbol	Parameter	Minimum	Typical	Maximum	Unit
V_{DDSEx} ¹	Power supply voltage for supporting 1.8V outputs.	1.71	1.8	1.89	V
	Power supply voltage for supporting 2.5V outputs.	2.375	2.5	2.625	V
	Power supply voltage for supporting 3.3V outputs.	3.135	3.3	3.465	V
V_{DD33} ²	Power supply voltage for core logic functions.	3.135	3.3	3.465	V
V_{DDA}	Analog power supply voltage. Use filtered analog power supply if available.	2.375	-	3.465	V
V_{BAT}	Battery power supply voltage.	2.8	3	3.465	V
T_A	Operating temperature, ambient.	-40	-	85	°C
C_{LOAD_OUT}	Maximum load capacitance (3.3V LVCMOS only).	-	5	-	pF
t_{PU}	Power-up time for all V_{DDs} to reach minimum specified voltage (power ramps must be monotonic).	0.05	-	3	ms

¹ Power-up sequence conditions.

² V_{DDSEx} for non-32kHz outputs should be OFF when V_{DDA}/V_{DD33} turned OFF; V_{BAT} mode only supports 32.768kHz outputs from SE1–3.

Input Capacitance, LVCMOS Output Impedance, and Internal Pull-down

Table 12. Input Capacitance, LVCMOS Output Impedance, and Internal Pull-down

Symbol	Parameter	Minimum	Typical	Maximum	Unit
C_{IN}	Input Capacitance (OE, SDA, SCL, DFC1:0)	-	3	7	pF
Pull-down Resistor	OE	-	200	-	k Ω
R_{OUT}	LVCMOS Output Driver Impedance ($V_{DDSE} = 1.8V$)	-	22	-	
	LVCMOS Output Driver Impedance ($V_{DDSE} = 2.5V$)	-	22	-	
	LVCMOS Output Driver Impedance ($V_{DDSE} = 3.3V$)	-	22	-	Ω
Internal C XIN/XOUT	Programmable Input Capacitance	-	16	-	pF

Electrical Characteristics

Table 13. DC Electrical Characteristics (Industrial)^{1,2}

Symbol	Parameter	Conditions	Minimum	Typical	Maximum	Unit
I_{DDCORE}	Core Supply Current	$V_{DD} = V_{DDSE} = V_{DD33} = 3.3V$; XTAL = 25MHz, PLL2/3 off, no output, PLLs disabled.	-	5	-	mA
$I_{DD_PLL1}^3$	PLL1 Supply Current	$V_{DD} = V_{DDSE} = V_{DD33} = 3.3V$; XTAL = 25MHz, PLL2/3 off, no output, PLL1 = 600MHz.	-	13	-	mA
		$V_{DD} = V_{DDSE} = V_{DD33} = 2.5V$; XTAL = 25MHz, PLL2/3 off, no output, PLL1 = 600MHz.	-	13	-	mA
$I_{DD_PLL2}^3$	PLL2 Supply Current	$V_{DD} = V_{DDSE} = V_{DD33} = 3.3V$; XTAL = 25MHz, PLL1/3 off, no output, PLL2 = 1GHz.	-	11	-	mA
		$V_{DD} = V_{DDSE} = V_{DD33} = 2.5V$; XTAL = 25MHz, PLL1/3 off, no output, PLL2 = 1GHz.	-	11	-	mA
$I_{DD_PLL3}^3$	PLL3 Supply Current	$V_{DD} = V_{DDSE} = V_{DD33} = 3.3V$; XTAL = 25MHz, PLL1/2 off, no output, PLL3 = 480MHz.	-	4	-	mA
I_{DDOX}	Output Buffer Supply Current	LVPECL, 500MHz, 3.3V V_{DDDIFF} (DIFF1,2).	-	39	-	mA
		LVPECL, 156.25MHz, 2.5V V_{DDDIFF} (DIFF1,2).	-	33	-	mA
		LVDS, 500MHz, 3.3V V_{DDDIFF} (DIFF1,2).	-	13	-	mA
		LVDS, 250MHz, 2.5V V_{DDDIFF} (DIFF1,2).	-	8	-	mA
		LPHCSL, 125MHz, 3.3V V_{DDDIFF} , 2pF load (DIFF1,2).	-	7	-	mA
		LPHCSL, 100MHz, 2.5V V_{DDDIFF} , 2pF load (DIFF1,2).	-	8	-	mA
		LVCMOS, 8MHz, 3.3V, $V_{DDSE}^{1,2}$ (SE1).	-	1	-	mA
		LVCMOS, 8MHz, 2.5V $V_{DDSE}^{1,2}$ (SE1).	-	1	-	mA
		LVCMOS, 8MHz, 1.8V $V_{DDSE}^{1,2}$ (SE1).	-	1	-	mA
		LVCMOS, 160MHz, 3.3V V_{DDSE}^1 (SE1).	-	9.5	-	mA
		LVCMOS, 160MHz, 2.5V $V_{DDSE}^{1,2}$ (SE1).	-	5.0	-	mA
		LVCMOS, 160MHz, 1.8V $V_{DDSE}^{1,2}$ (SE1).	-	6.0	-	mA

Table 13. DC Electrical Characteristics (Industrial)^{1,2} (Cont.)

Symbol	Parameter	Conditions	Minimum	Typical	Maximum	Unit
I_{DDPD}	Power Down Current	PD asserted with V_{DDA} , V_{DD33} and V_{DDSE} on, I ² C programming, 32kHz running.	-	3.5	-	mA
$I_{DDSUSPEND} - V_{DD33}$	$I_{DDSUSPEND} - V_{BAT}$	Only $V_{BAT} = 3.3V$ and V_{DDSEn} is powered.	-	1.1	-	μA
$I_{DDSUSPEND} - SE_n 3.3V$	$I_{DDSUSPEND} - V_{DDSEn} 3.3V$	Only $V_{BAT} = 3.3V$ and V_{DDSEn} is powered with 3.3V.	-	3.4	-	μA
$I_{DDSUSPEND} - SE_n 2.5V$	$I_{DDSUSPEND} - V_{DDSEn} 2.5V$	Only $V_{BAT} = 3.3V$ and V_{DDSEn} is powered with 2.5V.	-	2.5	-	μA
$I_{DDSUSPEND} - SE_n 1.8V$	$I_{DDSUSPEND} - V_{DDSEn} 1.8V$	Only $V_{BAT} = 3.3V$ and V_{DDSEn} is powered with 1.8V.	-	1.8	-	μA

¹ Single CMOS driver active.

² SE1–3 current measured with 2 inches transmission line and 5pF load, DIFF clock current measured with 5 inches transmission line with 2pF loads.

³ $I_{DCCORE} = I_{DDA} + I_{DDD}$, no loads.

Electrical Characteristics – V_{DDDIFF}

Table 14. DC Electrical Characteristics for LVDS

($V_{DDDIFF} = 3.3V \pm 5\%$, 2.5V 5%, $T_A = -40^\circ C$ to $+85^\circ C$)

Symbol	Parameter	Minimum	Typical	Maximum	Unit	Notes
VOT (+)	Differential Output Voltage for the TRUE Binary State	247	-	454	mV	-
VOT (-)	Differential Output Voltage for the FALSE Binary State	-454	-	-247	mV	-
ΔVOT	Change in VOT between Complementary Output States	-	-	50	mV	-
VOS	Output Common Mode Voltage (Offset Voltage)	1.125	1.25	1.375	V	-
ΔVOS	Change in VOS between Complimentary Output States	-	-	50	mV	-
I_{OS}	Outputs Short Circuit Current, V_{OUT+} or $V_{OUT-} = 0V$ or V_{DDDIFF}	-	9	24	mA	-
I_{OSD}	Differential Outputs Short Circuit Current, $V_{OUT+} = V_{OUT-}$	-	6	12	mA	-
Jitter _{Cy/Cy}	Cycle to Cycle Jitter	-	20	-	ps	1,2
Jitter _{STJ}	Jitter - ST	-	100	-	ps	1,2
Duty Cycle	Duty Cycle	45	-	55	%	1,2
Measured Frequency	LVDS at Differential Output	-	-	500	MHz	1,2

¹ Guaranteed by design and characterization, not 100% tested in production.

² Measured from differential waveform.

Table 15. DC Electrical Characteristics for LVPECL

($V_{DDIFF} = 3.3V \pm 5\%$, $2.5V \pm 5\%$, $T_A = -40^\circ C$ to $+85^\circ C$)

Symbol	Parameter	Minimum	Typical	Maximum	Unit	Notes
V_{OH}	Output Voltage High, Terminated through 50Ω tied to $V_{DDIFF} - 2V$	$V_{DDIFF} - 1.19$	-	$V_{DDIFF} - 0.69$	V	-
V_{OL}	Output Voltage Low, Terminated through 50Ω tied to $V_{DDIFF} - 2V$	$V_{DDIFF} - 1.94$	-	$V_{DDIFF} - 1.4$	V	-
V_{SWING}	Output Differential Voltage Swing	1.1	-	2	V	2,3
Jitter _{Cy/Cy}	Cycle to Cycle Jitter	-	20	-	ps	1,2
Jitter _{STJ}	Jitter - ST	-	100	-	ps	1,2
Duty Cycle	Duty Cycle	45	-	55	%	1,2
Measured Frequency	LVPECL at Differential Output	-	-	500	MHz	1,2

¹ Guaranteed by design and characterization, not 100% tested in production.

² Measured from differential waveform.

³ Differential clock amplitude setting = 01.

Table 16. Electrical Characteristics—DIF 0.7V LP-HCSL Differential Outputs

($V_{DDIFF} = 3.3V \pm 5\%$, $2.5V \pm 5\%$, $T_A = -40^\circ C$ to $+85^\circ C$)

Symbol	Parameter	Minimum	Typical	Maximum	Unit	Notes
dV/dt	Slew Rate	1	2.5	4	V/ns	1,2,3,8
$\Delta dV/dt$	Slew Rate Mismatch	-	-	20	%	1,2,3,8 at $\leq 200MHz$
V_{HIGH}	Voltage High	660	780	1150	mV	1,6,7,8
V_{LOW}	Voltage Low	-150	0	150	mV	1,6
V_{MAX}	Maximum Voltage	-	-	1150	mV	1
V_{MIN}	Minimum Voltage	-300	-	-	mV	1
V_{SWING}	Voltage Swing	300	-	-	mV	1,2
V_{CROSS}	Crossing Voltage Value	250	400	550	mV	1,4,6
ΔV_{CROSS}	Crossing Voltage Variation	-	-	140	mV	1,5
Jitter _{Cy/Cy}	Cycle to Cycle Jitter	-	20	-	ps	1,2
Jitter _{STJ}	Short Term Jitter	-	100	-	ps	1,2
Duty Cycle	Duty Cycle	45	-	55	%	1,2
Measured Frequency	LP-HCSL at Differential Output	-	-	500	MHz	1,2

¹ Guaranteed by design and characterization, not 100% tested in production.

² Measured from differential waveform.

³ Slew rate is measured through the V_{SWING} voltage range centered around differential 0V. This results in a $\pm 150mV$ window around differential 0V.

⁴ V_{CROSS} is defined as voltage where Clock = Clock# measured on a component test board and only applies to the differential rising edge (i.e. Clock rising and Clock# falling).

- ⁵ The total variation of all V_{CROSS} measurements in any particular system. Note that this is a subset of V_{CROSS} min/max (V_{CROSS} absolute) allowed. The intent is to limit V_{CROSS} induced modulation by setting ΔV_{CROSS} to be smaller than V_{CROSS} absolute.
- ⁶ Measured from single-ended waveform.
- ⁷ Measured with scope averaging off, using statistics function. Variation is difference between minimum and maximum.
- ⁸ Scope average ON.

Table 17. PCI Express Jitter Specifications

($V_{DDIFF} = 3.3V +5\%$ or $2.5V +5\%$, $T_A = -40^{\circ}C$ to $+85^{\circ}C$)

Symbol	Parameter	Conditions	Minimum	Typical	Maximum	PCIe Industry Specification	Unit	Notes
t_J (PCIe Gen1)	Phase Jitter Peak-to-Peak	$f = 100MHz/125MHz, 25MHz$ crystal input. Evaluation band: 0Hz – Nyquist (clock frequency/2).	-	37	-	86	ps	1,4
$t_{REFCLK_HF_RMS}$ (PCIe Gen2)	Phase Jitter RMS	$f = 100MHz/125MHz, 25MHz$ crystal input. High band: 1.5MHz – Nyquist (clock frequency/2).	-	2.1	-	3.10	ps	2,4
$t_{REFCLK_LF_RMS}$ (PCIe Gen2)	Phase Jitter RMS	$f = 100MHz/125MHz, 25MHz$ crystal input. Low band: 10kHz – 1.5MHz.	-	1.5	-	3.0	ps	2,4
t_{REFCLK_RMS} (PCIe Gen3)	Phase Jitter RMS	$f = 100MHz/125MHz, 25MHz$ crystal input. Evaluation band: 0Hz – Nyquist (clock frequency/2).	-	0.55	-	1.0	ps	3,4

Electrical parameters are guaranteed over the specified ambient operating temperature range, which is established when the device is mounted in a test socket with maintained transverse airflow greater than 500 lfm. The device will meet specifications after thermal equilibrium has been reached under these conditions.

- ¹ Peak-to-peak jitter after applying system transfer function for the common clock architecture; maximum limit for PCI Express Gen 1.
- ² RMS jitter after applying the two evaluation bands to the two transfer functions defined in the common clock architecture and reporting the worst case results for each evaluation band. Maximum limit for PCI Express Generation 2 is 3.1ps RMS for $t_{REFCLK_HF_RMS}$ (high band) and 3.0ps RMS for $t_{REFCLK_LF_RMS}$ (low band).
- ³ RMS jitter after applying system transfer function for the common clock architecture. This specification is based on the PCI_Express_Base_r3.0 10 Nov, 2010 specification, and is subject to change pending the final release version of the specification.
- ⁴ This parameter is guaranteed by characterization, not tested in production.

Electrical Characteristics – V_{DDSE}

Table 18. DC Electrical Characteristics for 3.3V LVC MOS

(V_{DDSE} = 3.3V ±5%, T_A = -40°C to +85°C)

Symbol	Parameter	Conditions	Minimum	Typical	Maximum	Unit
V _{OH}	Output High Voltage	I _{OH} = -15mA.	2.4	-	V _{DDSE}	V
V _{OL}	Output Low Voltage	I _{OL} = 15mA.	-	-	0.4	V
I _{OZDD}	Output Leakage Current	Tri-state outputs, V _{DDSE} = 3.465V.	-	-	3	μA
V _{IH}	Input High Voltage	Single-ended inputs – OE, SDA, SCL.	2	-	V _{DDSE} + 0.3	V
V _{IL}	Input Low Voltage	Single-ended inputs – OE, SDA, SCL.	GND - 0.3	-	0.8	V

Table 19. DC Electrical Characteristics for 2.5V LVC MOS

(V_{DDSE} = 2.5V ±5%, T_A = -40°C to +85°C)

Symbol	Parameter	Conditions	Minimum	Typical	Maximum	Unit
V _{OH}	Output High Voltage	I _{OH} = -12mA.	0.7 x V _{DDSE}	-	V _{DDSE}	V
V _{OL}	Output Low Voltage	I _{OL} = 12mA.	-	-	0.4	V
I _{OZDD}	Output Leakage Current	Tri-state outputs, V _{DDSE} = 2.625V.	-	-	3	μA
V _{IH}	Input High Voltage	Single-ended inputs – OE, SDA, SCL.	1.7	-	V _{DDSE} + 0.3	V
V _{IL}	Input Low Voltage	Single-ended inputs – OE, SDA, SCL.	GND - 0.3	-	0.8	V

Table 20. DC Electrical Characteristics for 1.8V LVC MOS

(V_{DDSE} = 1.8V ±5%, T_A = -40°C to +85°C)

Symbol	Parameter	Conditions	Minimum	Typical	Maximum	Unit
V _{OH}	Output High Voltage	I _{OH} = -8mA.	0.7 x V _{DDSE}	-	V _{DDSE}	V
V _{OL}	Output Low Voltage	I _{OL} = 8mA.	-	-	0.25 x V _{DDSE}	V
I _{OZDD}	Output Leakage Current	Tri-state outputs, V _{DDSE} = 1.89V.	-	-	3	μA
V _{IH}	Input High Voltage	Single-ended inputs – OE, SDA, SCL.	0.65 x V _{DDSE}	-	V _{DDSE} + 0.3	V
V _{IL}	Input Low Voltage	Single-ended inputs – OE, SDA, SCL.	GND - 0.3	-	0.35 x V _{DDSE}	V

Table 21. Power Consumption of 32.768kHz Output Only Operation

($V_{DDSE} = 3.3V +5\%$, $2.5V +5\%$, or $1.8V \pm 5\%$. $T_A = -40^{\circ}C$ to $+85^{\circ}C$)

Symbol	Parameter	Conditions	Minimum	Typical	Maximum	Unit
I_{VBAT}	$V_{BAT} = 3.3V$ Power Input Current		-	1.2	-	μA
I_{VDDSE^X}	$V_{DDSE^X} = 1.8V$ Current	0.5 inch, no load, one output.	-	0.4	-	μA
I_{VDDSE^X}	$V_{DDSE^X} = 1.8V$ Current	2.0 inch, no load, one output.	-	1.0	-	μA
I_{VDDSE^X}	$V_{DDSE^X} = 1.8V$ Current	5.0 inch, no load, one output.	-	2.3	-	μA
I_{VDDSE^X}	$V_{DDSE^X} = 2.5V$ Current	0.5 inch, no load, one output.	-	0.6	-	μA
I_{VDDSE^X}	$V_{DDSE^X} = 2.5V$ Current	2.0 inch, no load, one output.	-	1.5	-	μA
I_{VDDSE^X}	$V_{DDSE^X} = 2.5V$ Current	5.0 inch, no load, one output.	-	3.1	-	μA
I_{VDDSE^X}	$V_{DDSE^X} = 3.3V$ Current	0.5 inch, no load, one output.	-	0.8	-	μA
I_{VDDSE^X}	$V_{DDSE^X} = 3.3V$ Current	2.0 inch, no load, one output.	-	1.9	-	μA
I_{VDDSE^X}	$V_{DDSE^X} = 3.3V$ Current	5.0 inch, no load, one output.	-	4.2	-	μA

AC Electrical Characteristics

Table 22. AC Timing Electrical Characteristics

($V_{DDSE} = 3.3V +5\%$, $2.5V +5\%$, or $1.8V \pm 5\%$, $T_A = -40^\circ C$ to $+85^\circ C$; spread spectrum = OFF)

Symbol	Parameter	Conditions	Minimum	Typical	Maximum	Unit
f_{OUT}	Output Frequency	Single-ended clock output limit (LVCMOS).	1	< 125	160	MHz
		Differential clock output limit (LP-HCSL).	1	< 333	500	
		Differential clock output limit (LVDS).	1	< 333	500	
		Differential clock output limit (LVPECL).	1	-	500	MHz
f_{VCO1}	VCO Frequency Range of PLL1	VCO operating frequency range.	300	-	600	MHz
f_{VCO2}	VCO Frequency Range of PLL2	VCO operating frequency range.	400	-	1200	MHz
f_{VCO3}	VCO Frequency Range of PLL3	VCO operating frequency range.	300	-	800	MHz
t2	Input Duty Cycle	Duty cycle.	45	-	55	%
t3	Output Duty Cycle	LVCMOS and differential clock < 333MHz, crossing point measurements.	45	-	55	%
t3	Output Duty Cycle	LVCMOS and differential clock > 333MHz, crossing point measurements.	40	-	60	%
t3	Output Duty Cycle_REF	Reference clock output or SE1–3 fan out clock.	40	-	60	%
t4	Rise/Fall, SLEW[0] = 1	Single-ended LVCMOS output clock rise and fall time, 20% to 80% of V_{DDSE} 1.8V–3.3V.	-	1.0	-	ns
	Rise/Fall, SLEW[0] = 0	Single-ended LVCMOS output clock rise and fall time, 20% to 80% of V_{DDSE} 1.8V–3.3V.	-	1.1	-	
t5	Rise Times	LVDS, 20% to 80%.	-	300	-	ps
	Fall Times	LVDS, 80% to 20%.	-	300	-	
	Rise Times	LVPECL, 20% to 80%.	-	300	-	
	Fall Times	LVPECL, 80% to 20%.	-	300	-	
t6	Clock Jitter	Cycle-to-cycle jitter (peak-to-peak), multiple output frequencies switching, differential outputs (1.8V to 3.3V nominal output voltage). SE1 = 25MHz. SE2 = 100MHz. SE3 = 125MHz. DIFF1/2 = 100MHz.	-	50	-	ps
		RMS phase jitter (12kHz to 20MHz integration range) differential output, $V_{DDSE} = 3.465V$, 25MHz crystal. SE1 = 25MHz. SE2 = 100MHz. SE3 = 125MHz. DIFF1/2 = 100MHz.	-	1.57	-	ps
t7	Output Skew	Skew between the same frequencies with outputs using the same driver format.	-	152	-	ps

Table 22. AC Timing Electrical Characteristics (Cont.)

($V_{DDSE} = 3.3V +5\%$, $2.5V +5\%$, or $1.8V \pm 5\%$, $T_A = -40^\circ C$ to $+85^\circ C$; spread spectrum = OFF)

Symbol	Parameter	Conditions	Minimum	Typical	Maximum	Unit
$t8^2$	Lock Time	PLL lock time from power-up.	-	-	20	ms
$t9$	Lock Time	32.768kHz clock, low power, power-up time.	-	10	100	ms
$t9^3$	Lock Time	PLL lock time from shutdown mode.	-	0.1	2	ms
$T_{CRYSTAL}$	Frequency Stability	Initial frequency accuracy at 25°C.	-	-	± 20	ppm
		Frequency stability across temperature.	-	-	± 20	ppm
		Aging per year.	-	-	± 2	ppm

¹ Practical lower frequency is determined by loop filter settings.

² Includes loading the configuration bits from EPROM to PLL registers. It does not include EPROM programming/write time.

³ Actual PLL lock time depends on the loop configuration.

⁴ $t4$ Rise/Fall time measurements are based on 5pF load.

⁵ $t5$ Rise/Fall time measurements are based on 2pF load.

Spread Spectrum Generation Specifications

Table 23. Spread Spectrum Generation Specification

Symbol	Parameter	Description	Minimum	Typical	Maximum	Unit
f_{OUT}	Output Frequency	Output frequency range.	1		350	MHz
f_{MOD}	Mod Frequency	Modulation frequency.	30 to 63			kHz
f_{SPREAD}	Spread Value	Amount of spread value (programmable) – down spread.	-0.5% to -5%			% f_{OUT}
%tolerance	Spread% Value	Variation of spread range.	-	± 15	-	%

Glossary of Features

Table 24. Glossary of Features

Term	Function Description	Apply to
DFC	Dynamic Frequency Control; from selected PLL to support four VCO frequencies; means two different output frequencies by assigned H/W pin state changes.	PLL2
ORT	Overshoot Reduction; when the DFC dynamic frequency change is functional, the VCO changes frequencies smoothly to target frequency without overshoot or undershoot.	PLL2
OE	Output Enable function; each output can be controlled by assigned OE pin and the dedicated OE pin can be OTP programmable as Global Power Down function (PD#) or Output enable (OE) or proactive power saving function (PPS) or RESET pin function.	OE1–3
SS	Spread spectrum clock.	PLL1/PLL2
Slew Rate	LVC MOS outputs with slew rate control – slow and fast.	LVC MOS
PPS	Proactive Power Saving; utilize OE pin as monitor pin for end device X2 clock status. See PPS Function description for details.	SE1–3

Device Features and Functions

DFC–Dynamic Frequency Control

- OTP program (only) setup 4 different feedback fractional divider (4 VCO frequencies) that apply to PLL2.
- ORT (overshoot reduction) function will be applied automatically during the VCO frequency change.
- Smooth frequency incremental or decremental from current VCO to targeted VCO base on DFC hardware pins selection.

Figure 2. DFC Block Diagram

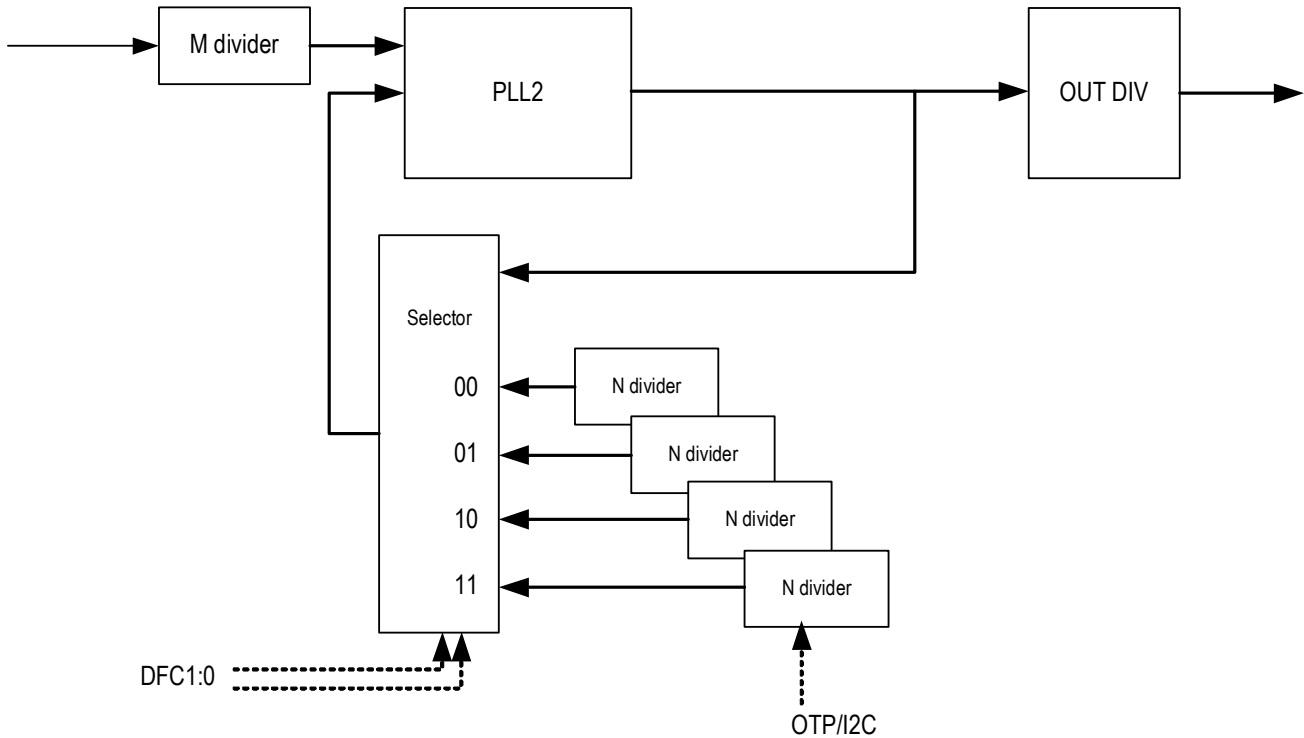

Table 25. DFC Function Priority

DFC_EN bit (W32[4])	OE1_fun_sel	OE3_fun_sel	SCL_DFC1	DFC[1:0]	Notes
1	11 (DFC)	00–10 (DFC)	x	[0,OE1]	One pin DFC – OE1
1	11 (DFC)	11 (DFC)	x	[OE3,OE1]	Two pin DFC – OE3,OE1
1	00–10	11	x	Not permitted	Not supported
1	00–10	00–10	0	[SCL_DFC1, SDA_DFC0]	I ² C pin as DFC control pins mode
1	00–10	00–10	1	W30[1:0]	I ² C control DFC mode
1	11 (DFC)	00–10 (DFC)	x	[0,OE1]	One pin DFC - OE1

DFC Function Programming

1. Register B63b3:2 selects DFC00–DFC11 configuration.
2. Byte16–19 are the registers for PLL2 VCO setting. Based on B63b3:2 configuration selection, the data write to B16–19 will be stored in the selected configuration OTP memory.
3. Refer to DFC Function Priority table; select proper control pin(s) to activate DFC function.
4. Note the DFC function can also be controlled by I²C access.

PPS–Proactive Power Saving Function

PPS Proactive Power Saving is an Renesas patented unique design for the clock generator that proactively detects end device power down state and then switches output clocks between the normal operation clock frequency, and the low power mode 32kHz clock that only consumes < 2μA current. The system could save power when the device goes into power down or sleep mode. The PPS function diagram is shown below.

Figure 3. PPS Function Block Diagram

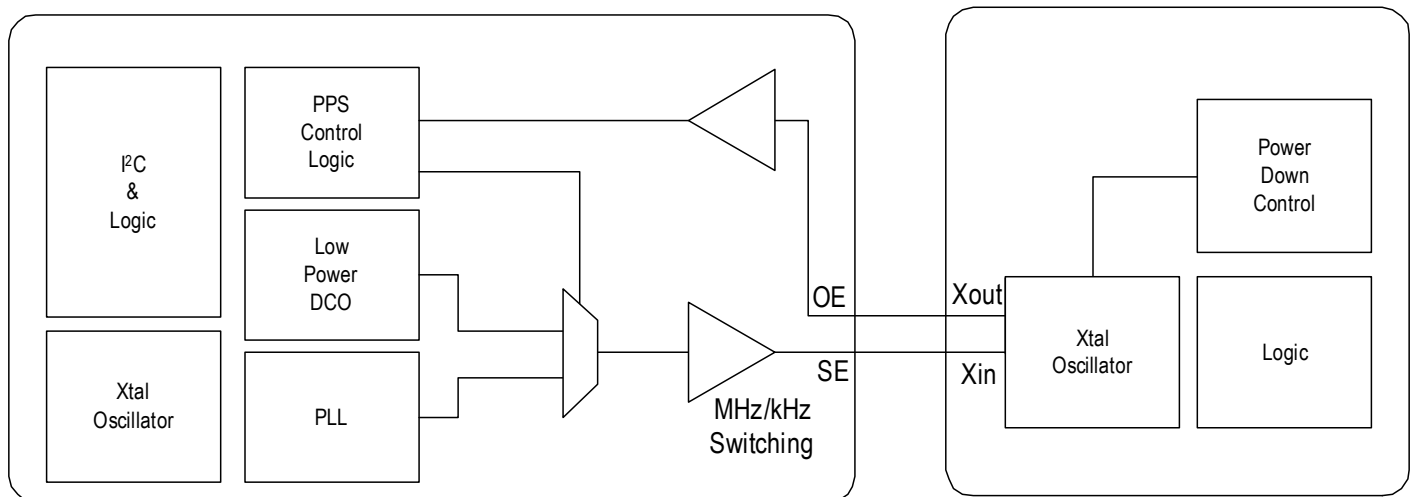
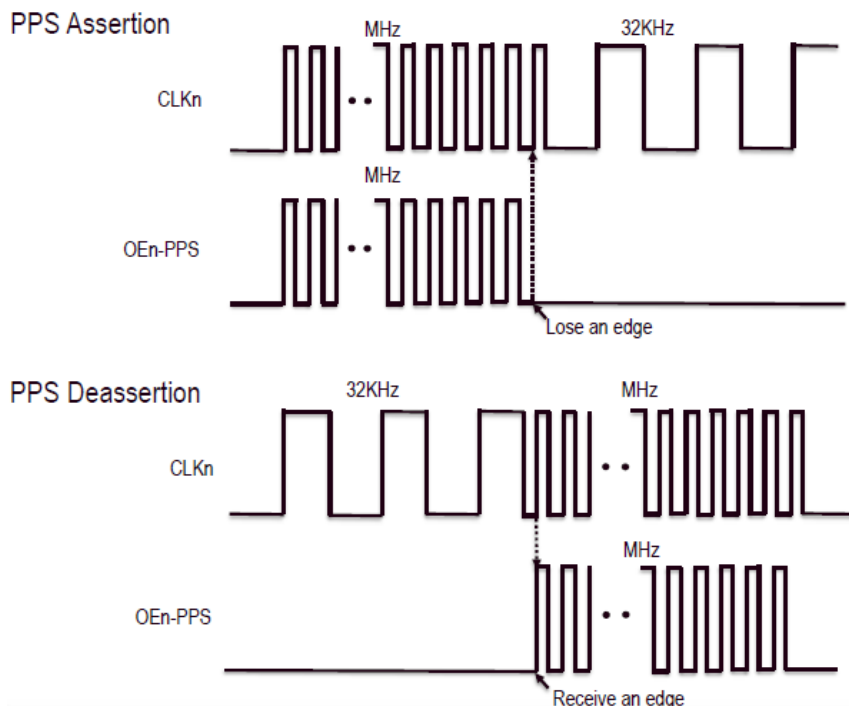

Figure 4. PPS Assertion/Deassertion Timing Chart



PPS Function Programming

1. Refer to OE_pin_fuction_table to have the proper PPS function selected for OE pin(s). Note that the register default is set to Output enable (OE) function for OE pins.
2. Have proper setup to Byte 30 and 32 for OE1–OE3 function selection; for PPS function, select 10 to control register bits.

Timer Function Description

1. The timer function can be used together with the DFC -Dynamic Frequency Control function or with another PLL frequency programming.
2. The timer provides 4 different delay times by two bits selection: 0.5 seconds, 1 seconds, 2 seconds, 4 seconds.
3. The timeout flag will be set when timer times out and the flag can be cleared by writing 0 to timer enable bit.
4. When timer times out, RESET pin can generate a 250ms pulse signal if RESET control bit is enabled.
5. When timer times out, DFC stage will switch back to DFC00 setting if DFC function is enabled and DFC function will be disabled after RESET.

Figure 5. Timer Functions

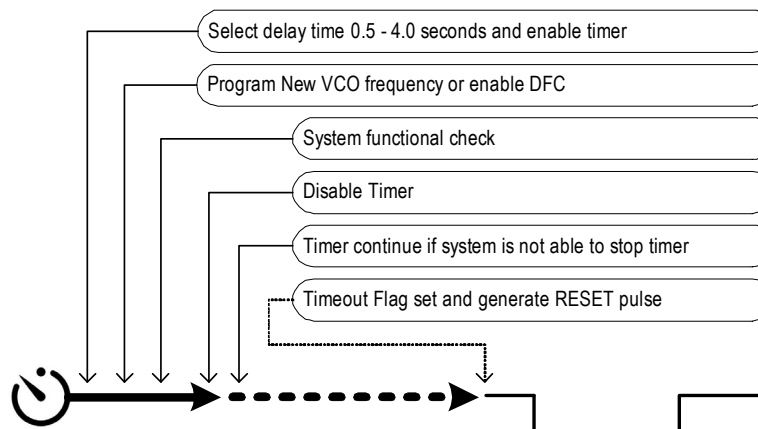

OE Pin Function

OE pins in the 5X35023 have multiple functions. The OE pins can be configured as output enable control (OE) or chip power-down control (PD#) or proactive power saving function (PPS). Furthermore, the OE pins can be configured as single or two pin dynamic frequency control (DFC), or the RESET out function that is associated with the Timer function.

Table 26. OE Pin Functions

Function	Pin		
	OE1	OE2	OE3
SE Output Enable/Disable	SE1 (default)	SE2 (default)	SE3 (default)
DIFF Output Enable/Disable	-	DIFF1/DIFF2	-
Global Power Down (PD#)	PD#	-	-
Proactive Power Saving Input	SE1_PPS	SE2_PPS	SE3_PPS
DOC Control (Only PLL2)	DFC0	-	DFC1
RESET OUT	-	RESET OUT	-

Table 27. OE Pin Function Summary

OE Pin	Description
OE1: SE1	OE1 only control SE1 enable/disable; other outputs are not affected by this pin status.
OE2: SE2	OE2 only control SE2 enable/disable; other outputs are not affected by this pin status.
OE2: SE3	OE3 only control SE3 enable/disable; other outputs are not affected by this pin status.
OE2: DIFF1/DIFF2	OE2 control differential outputs 1 and 2 only; other SE outputs are not affected by this pin status.
OE1: PD#	OE1 control chip global power down (PD#) except 32.768kHz on OE1 (when 32K is enabled). When the PD# pin is active low, the chip goes to lowest power down mode and all outputs are disabled except 32kHz output and only keep 32K/Xtal calibration.
OE1: SE1_PPS	Configure OE1 as SE1_PPS (Proactive Power Saving) function pin.
OE2: SE2_PPS	Configure OE2 as SE2_PPS (Proactive Power Saving) function pin.
OE3: SE3_PPS	Configure OE3 as SE3_PPS (Proactive Power Saving) function pin.
OE1: DFC0	Configure OE1 as DFC0 control pin 0.
OE3/DFC1	Configure OE3 as DFC1 control pin 1.

Table 28. PD# Priority

PD#	I2C_OE_EN_bit	SE1/2/3, DIFF1/DIFF2	Output	Notes
0	x	x	stop	32kHz free run
1	0	x	stop	-
1	1	0	stop	-
1	1	1	running	-

Spread Spectrum

The 5X35023 supports spread spectrum clocks from PLL1 and PLL2; the PLL1 built-in with analog spread spectrum and PLL2 has digital spread spectrum.

Figure 6. Digital Spread Spectrum

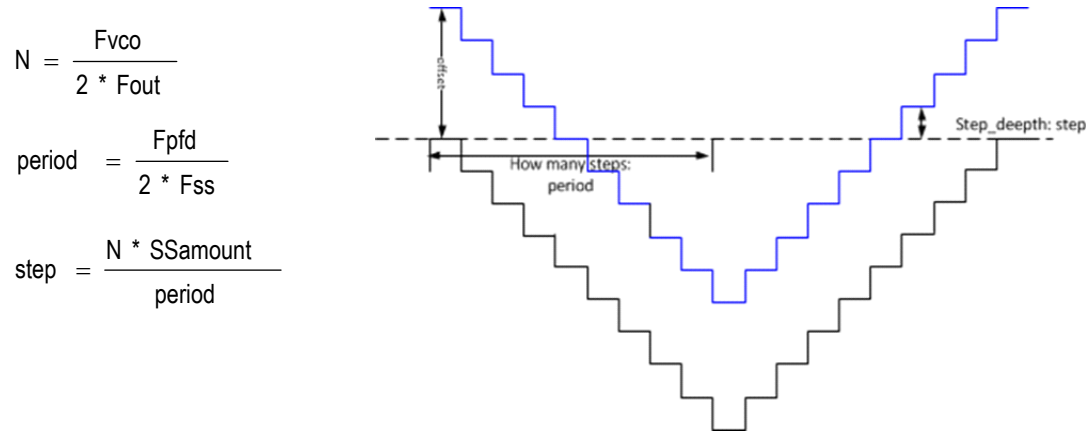

Down spread or Spread off

$$N = F_{vco}/F_{pfd}$$

Center Spread

$$N = N_{ssoff} + N * SS_{amount}/2$$

N: include integer and fraction

Fvco: VCOs frequency

Fpfd: PLLs pfd frequency

Fss: spread modulation rate

SSamount: spread percentage

The black line is for the down spread; N will decrease to make the center frequency is lower than spread off.

The blue line is for the center spread; there is an offset put on divider ratio to make the center frequency keep same as spread off.

VBAT

The 5X35023 V_{BAT} supports a low-power operation 32.768kHz RTC clock with only coin cell battery supply. The coin cell battery power capacitance is usually 170mAh or higher, with less than 2 μ A low-power DCO operation mode will support application up to few years clock source for date/time keeping circuit (RTC).

When there is main power existing in V_{DD33} and V_{DDA} , the 5X35023 will switch DCO power source to main power to save battery power.

Figure 7. V_{BAT} Switching Threshold

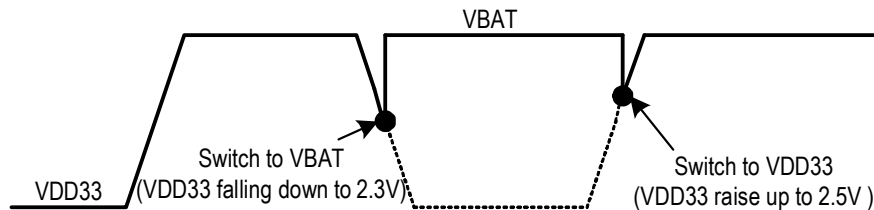

V_{DD33}	V_{BAT}	DCO Power Source
> 2.5V	—	V_{DD33}
< 2.3V	—	V_{BAT}

ORT-VCO Overshoot Reduction Technology

The 5X35023 supports the VCO overshoot reduction technology (ORT) to prevent an output clock frequency spike when the device is changing frequency on the fly or doing DFC (Dynamic Frequency Control) function. The VCO frequency changes are under control instead of free-run to targeted frequency.

PLL Features and Descriptions

Table 29. Output 1 Divider

Output Divider bits <1:0>	Output Divider bits <3:2>			
	00	01	10	11
00	1	2	4	8
01	4	8	16	32
10	5	10	20	40
11	6	12	24	48

Table 30. Output 2, 4, and 5 Divider

Output Divider bits <1:0>	Output Divider bits <3:2>			
	00	01	10	11
00	1	2	4	5
01	3	6	12	15
10	5	10	20	25
11	10	20	40	50

Table 31. Output 3 Divider

Output Divider bits <1:0>	Output Divider bits <3:2>			
	00	01	10	11
00	1	2	4	8
01	3	6	12	24
10	5	10	20	40
11	10	20	40	80

Output Clock Test Conditions

Figure 8. LVCMOS Output Test Conditions

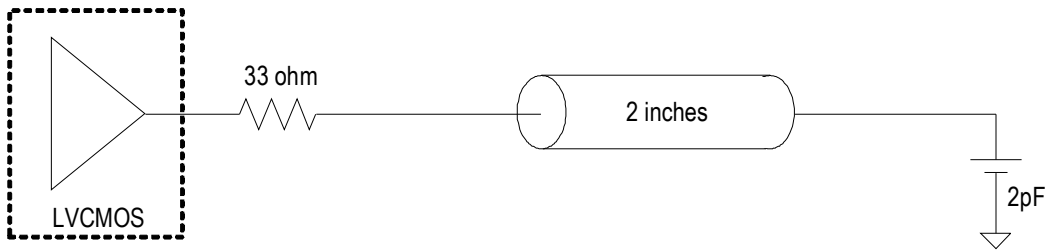
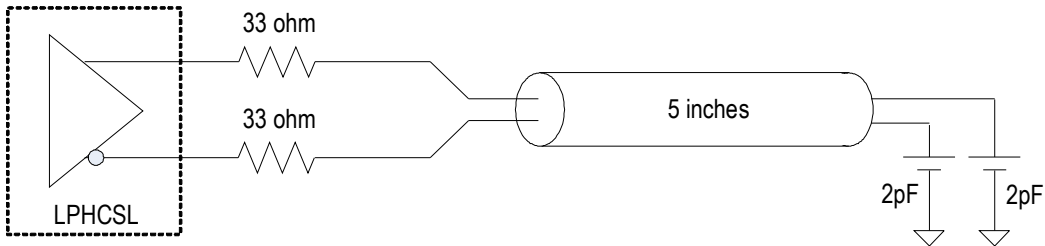

Figure 9. LP-HCSL Output Test Conditions



I²C Bus Characteristics

Table 32. I²C Bus DC Characteristics

Symbol	Parameter	Conditions	Minimum	Typical	Maximum	Unit
V _{IH}	Input High Level	-	0.7 × V _{DD33}	-	-	V
V _{IL}	Input c Level	-	-	-	0.3 × V _{DD33}	V
V _{HYS}	Hysteresis of Inputs	-	0.05 × V _{DD33}	-	-	V
I _{IN}	Input Leakage Current	-	-	-	±1	μA
V _{OL}	Output Low Voltage	I _{OL} = 3mA	-	-	0.4	V

Table 33. I²C Bus AC Characteristics

Symbol	Parameter	Conditions	Minimum	Typical	Maximum	Unit
F _{SCLK}	Serial Clock Frequency (SCL)	-	-	100	400	kHz
t _{BUF}	Bus Free Time between STOP and START	-	1.3	-	-	μs
t _{SU:START}	Setup Time, START	-	0.6	-	-	μs
t _{HD:START}	Hold Time, START	-	0.6	-	-	μs
t _{SU:DATA}	Setup Time, Data Input (SDA)	-	100	-	-	ns
t _{HD:DATA}	Hold Time, Data Input (SDA) 1	-	0	-	-	μs
t _{OVD}	Output Data Valid from Clock	-	-	-	0.9	μs
C _B	Capacitive Load for Each Bus Line	-	-	-	400	pF
t _R	Rise Time, Data and Clock (SDA, SCL)	-	20 + 0.1 × C _B	-	300	ns
t _F	Fall Time, Data and Clock (SDA, SCL)	-	20 + 0.1 × C _B	-	300	ns
t _{HIGH}	High Time, Clock (SCL)	-	0.6	-	-	μs
t _{LOW}	High Time, Clock (SCL)	-	1.3	-	-	μs
t _{SU:STOP}	Setup Time, STOP	-	0.6	-	-	μs

General I²C Mode Operations

The device acts as a slave device on the I²C bus using one of the four I²C addresses (0xD0, 0xD2, 0xD4, or 0xD6) to allow multiple devices to be used in the system. The interface accepts byte-oriented block write and block read operations. Two address bytes specify the register address of the byte position of the first register to write or read. Data bytes (registers) are accessed in sequential order from the lowest to the highest byte (most significant bit first). Read and write block transfers can be stopped after any complete byte transfer. During a write operation, data will not be moved into the registers until the STOP bit is received, at which point, all data received in the block write will be written simultaneously.

For full electrical I²C compliance, it is recommended to use external pull-up resistors for SDATA and SCLK. The internal pull-down resistors have a size of 100kΩ typical.

Figure 10. I²C Slave Read and Write Cycle Sequencing

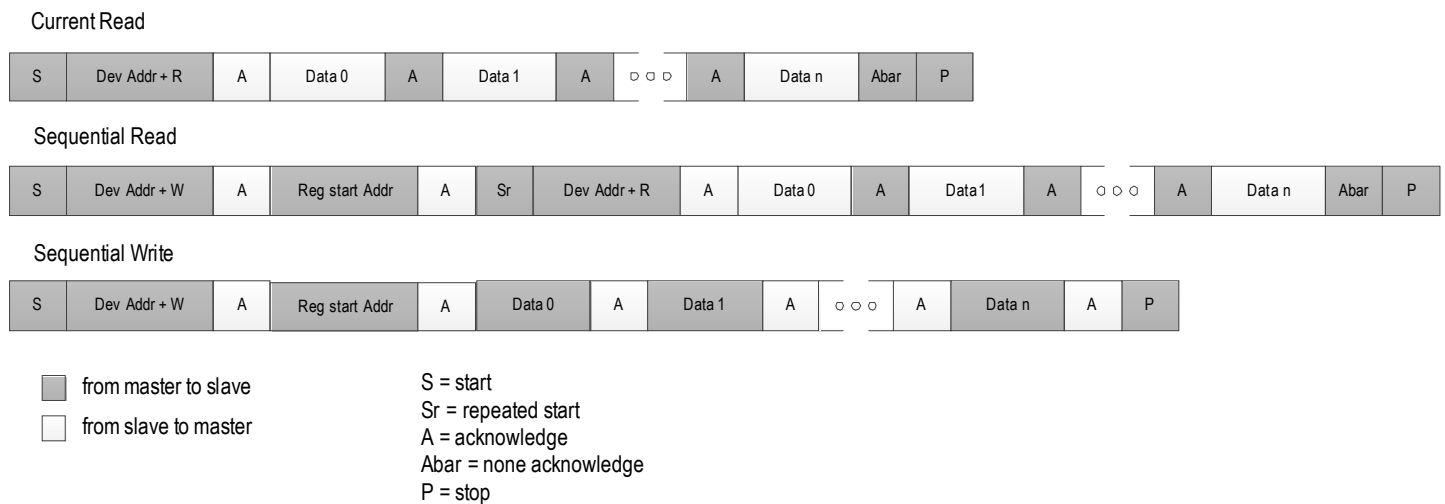

Byte 0: General Control

Byte 00h	Name	Control Function	Type	0	1	PWD
Bit 7	OTP_Burned	OTP memory programming indication	R/W	OTP memory non-programmed	OTP memory programmed	0
Bit 6	I2C_addr[1]	I2C address select bit 1	R/W	00: D0 / 01: D2 10: D4 / 11: D6		0
Bit 5	I2C_addr[0]	I2C address select bit 0	R/W			0
Bit 4	PLL1_SSEN	PLL1 Spread Spectrum enable	R/W	disable	enable	0
Bit 3	DIV1_src_sel	Divider 1 source clock select	R/W	PLL1	Xtal	0
Bit 2	PLL3_refin_sel	PLL3 source selection	R/W	Xtal	Seed (DIV2)	0
Bit 1	EN_CLKIN	Enable CLKIN	R/W	disable	enable	0
Bit 0	OTP_protect	OTP memory protection	R/W	read/write	write locked	0

Byte 1: Dash Code ID (optional)

Byte 01h	Name	Control Function	Type	0	1	PWD
Bit 7	DashCode ID[7]	Dash code ID	R/W	-	-	0
Bit 6	DashCode ID[6]	Dash code ID	R/W	-	-	0
Bit 5	DashCode ID[5]	Dash code ID	R/W	-	-	0
Bit 4	DashCode ID[4]	Dash code ID	R/W	-	-	0
Bit 3	DashCode ID[3]	Dash code ID	R/W	-	-	0
Bit 2	DashCode ID[2]	Dash code ID	R/W	-	-	0
Bit 1	DashCode ID[1]	Dash code ID	R/W	-	-	0
Bit 0	DashCode ID[0]	Dash code ID	R/W	-	-	0

Byte 2: Crystal Cap Setting

Byte 02h	Name	Control Function	Type	0	1	PWD
Bit 7	Xtal_Cap[7]	Xtal cap load trimming bits	R/W	x1 x2 x4 x8 total 15pf		0
Bit 6	Xtal_Cap[6]	Xtal cap load trimming bits	R/W			0
Bit 5	Xtal_Cap[5]	Xtal cap load trimming bits	R/W			0
Bit 4	Xtal_Cap[4]	Xtal cap load trimming bits	R/W			1
Bit 3	Xtal_Cap[3]	Xtal cap load trimming bits	R/W			0
Bit 2	Xtal_Cap[2]	Xtal cap load trimming bits	R/W			0
Bit 1	Xtal_Cap[1]	Xtal cap load trimming bits	R/W			0
Bit 0	Xtal_Cap[0]	Xtal cap load trimming bits	R/W			1

Byte 3: PLL3 M Divider

Byte 03h	Name	Control Function	Type	0	1	PWD
Bit 7	PLL3_MDIV1	PLL3 source clock divider	R/W	disable M DIV1	bypadd divider (/1)	0
Bit 6	PLL3_MDIV2	PLL3 source clock divider	R/W	disable M DIV2	bypadd divider (/2)	0
Bit 5	PLL3 M_DIV[5]	PLL3 reference integer divider	R/W	3–64	default 25	0
Bit 4	PLL3 M_DIV[4]	PLL3 reference integer divider	R/W	-	-	1
Bit 3	PLL3 M_DIV[3]	PLL3 reference integer divider	R/W	-	-	1
Bit 2	PLL3 M_DIV[2]	PLL3 reference integer divider	R/W	-	-	0
Bit 1	PLL3 M_DIV[1]	PLL3 reference integer divider	R/W	-	-	0
Bit 0	PLL3 M_DIV[0]	PLL3 reference integer divider	R/W	-	-	1

Byte 4: PLL3 N Divider

Byte 04h	Name	Control Function	Type	0	1	PWD
Bit 7	PLL3 N_DIV[7]	PLL3 VCO feedback integer divider bit7	R/W	12~2048, default VCO setting is 480MHz		1
Bit 6	PLL3 N_DIV[6]	PLL3 VCO feedback integer divider bit6	R/W			1
Bit 5	PLL3 N_DIV[5]	PLL3 VCO feedback integer divider bit5	R/W			1
Bit 4	PLL3 N_DIV[4]	PLL3 VCO feedback integer divider bit4	R/W			0
Bit 3	PLL3 N_DIV[3]	PLL3 VCO feedback integer divider bit3	R/W			0
Bit 2	PLL3 N_DIV[2]	PLL3 VCO feedback integer divider bit2	R/W			0
Bit 1	PLL3 N_DIV[1]	PLL3 VCO feedback integer divider bit1	R/W			0
Bit 0	PLL3 N_DIV[0]	PLL3 VCO feedback integer divider bit0	R/W			0

Byte 5: PLL3 Loop Filter Setting and N Divider 10:8

Byte 05h	Name	Control Function	Type	0	1	PWD
Bit 7	PLL3_R100K	PLL3 Loop filter resister 100kOhm	R/W	bypass	plus 100kOhm	0
Bit 6	PLL3_R50K	PLL3 Loop filter resister 50kOhm	R/W	bypass	plus 50kOhm	0
Bit 5	PLL3_R25K	PLL3 Loop filter resister 25kOhm	R/W	bypass	plus 25kOhm	0
Bit 4	PLL3_R12.5K	PLL3 Loop filter resister 12.5kOhm	R/W	bypass	plus 12.5kOhm	1
Bit 3	PLL3_R6K	PLL3 Loop filter resister 6kOhm	R/W	bypass	only 6kOhm applied	0
Bit 2	PLL3 N_DIV[10]	PLL3 VCO feedback integer divider bit10	R/W	12~2048, default VCO setting is 480MHz		0
Bit 1	PLL3 N_DIV[9]	PLL3 VCO feedback integer divider bit9	R/W			0
Bit 0	PLL3 N_DIV[8]	PLL3 VCO feedback integer divider bit8	R/W			1

Byte 6: PLL3 Charge Pump Control

Byte 06h	Name	Control Function	Type	0	1	PWD
Bit 7	OUTDIV 3 Source	Output divider 3 source clock selection	R/W	PLL2	PLL3	0
Bit 6	PLL3_CP_8X	PLL3 charge pump control	R/W	-	x8	1
Bit 5	PLL3_CP_4X	PLL3 charge pump control	R/W	-	x4	1
Bit 4	PLL3_CP_2X	PLL3 charge pump control	R/W	-	x2	0
Bit 3	PLL3_CP_1X	PLL3 charge pump control	R/W	-	x1	1
Bit 2	PLL3_CP_/24	PLL3 charge pump control	R/W	-	/24	1
Bit 1	PLL3_CP_/3	PLL3 charge pump control	R/W	-	/3	0
Bit 0	PLL3_SIREF	PLL3 SiRef current selection	R/W	10μA	20μA	0

Formula: $(i_{Ref} (10\mu A) \times (1 + SIREF) \times (1 \times 1X + 2 \times 2X + 4 \times 4X + 8 \times 8X + 16 \times 16X)) / ((24 \times /24) + (3 \times /3))$

Byte 7: PLL1 Control and OUTDIV5 Divider

Byte 07h	Name	Control Function	Type	0	1	PWD
Bit 7	PLL1_MDIV_Doubler	PLL1 reference clock doubler	R/W	disable	enable	0
Bit 6	PLL1_SIREF	PLL1 SiRef current selection	R/W	10.8μA	21.6μA	0
Bit 5	PLL1_EN_CH2	PLL1 output Channel 2 control	R/W	disable	enable	1
Bit 4	PLL1_EN_3rdpole	PLL1 3rd Pole control	R/W	disable	enable	0
Bit 3	OUTDIV5[3]	Output divider5 control bit 3	R/W	-	-	0
Bit 2	OUTDIV5[2]	Output divider5 control bit 2	R/W	-	-	0
Bit 1	OUTDIV5[1]	Output divider5 control bit 1	R/W	-	-	1
Bit 0	OUTDIV5[0]	Output divider5 control bit 0	R/W	-	-	1

Byte 8: PLL1 M Divider

Byte 08h	Name	Control Function	Type	0	1	PWD
Bit 7	PLL1_MDIV1	PLL3 VCO reference clock divider 1	R/W	disable M DIV1	bypass divider (/1)	0
Bit 6	PLL1_MDIV2	PLL3 VCO reference clock divider 2	R/W	disable M DIV2	bypass divider (/2)	0
Bit 5	PLL1 M_DIV[5]	PLL1 reference clock divider control bit 5	R/W	3-64, default is 25		0
Bit 4	PLL1 M_DIV[4]	PLL1 reference clock divider control bit 4	R/W			1
Bit 3	PLL1 M_DIV[3]	PLL1 reference clock divider control bit 3	R/W			1
Bit 2	PLL1 M_DIV[2]	PLL1 reference clock divider control bit 2	R/W			0
Bit 1	PLL1 M_DIV[1]	PLL1 reference clock divider control bit 1	R/W			0
Bit 0	PLL1 M_DIV[0]	PLL1 reference clock divider control bit 0	R/W			1

Byte 9: PLL1 VCO N Divider

Byte 09h	Name	Control Function	Type	0	1	PWD
Bit 7	PLL1_N_DIV[7]	PLL1 VCO feedback divider control bit 7	R/W	12–2048, default is 600		0
Bit 6	PLL1_N_DIV[6]	PLL1 VCO feedback divider control bit 6	R/W			1
Bit 5	PLL1_N_DIV[5]	PLL1 VCO feedback divider control bit 5	R/W			0
Bit 4	PLL1_N_DIV[4]	PLL1 VCO feedback divider control bit 4	R/W			1
Bit 3	PLL1_N_DIV[3]	PLL1 VCO feedback divider control bit 3	R/W			1
Bit 2	PLL1_N_DIV[2]	PLL1 VCO feedback divider control bit 2	R/W			0
Bit 1	PLL1_N_DIV[1]	PLL1 VCO feedback divider control bit 1	R/W			0
Bit 0	PLL1_N_DIV[0]	PLL1 VCO feedback divider control bit 0	R/W			0

Byte 10: PLL Loop Filter and N Divider

Byte 0Ah	Name	Control Function	Type	0	1	PWD
Bit 7	PLL1_R100K	PLL1 Loop filter resister 100kOhm	R/W	bypass	plus 100kOhm	1
Bit 6	PLL1_R50K	PLL1 Loop filter resister 50kOhm	R/W	bypass	plus 50kOhm	0
Bit 5	PLL1_R25K	PLL1 Loop filter resister 25kOhm	R/W	bypass	plus 25kOhm	1
Bit 4	PLL1_R12.5K	PLL1 Loop filter resister 12.5kOhm	R/W	bypass	plus 12.5kOhm	1
Bit 3	PLL1_R1.0K	PLL1 Loop filter resister 1kOhm	R/W	bypass	only 1.0kOhm applied	0
Bit 2	PLL1_N_DIV[10]	PLL1 VCO feedback integer divider bit10	R/W	12–2048, default is 600		0
Bit 1	PLL1_N_DIV[9]	PLL1 VCO feedback integer divider bit9	R/W			1
Bit 0	PLL1_N_DIV[8]	PLL1 VCO feedback integer divider bit8	R/W			0

Byte 11: PLL1 Charge Pump

Byte 0Bh	Name	Control Function	Type	0	1	PWD
Bit 7	PLL1_CP_32X	PLL1 charge pump control	R/W	-	x32	0
Bit 6	PLL1_CP_16X	PLL1 charge pump control	R/W	-	x16	0
Bit 5	PLL1_CP_8X	PLL1 charge pump control	R/W	-	x8	0
Bit 4	PLL1_CP_4X	PLL1 charge pump control	R/W	-	x4	0
Bit 3	PLL1_CP_2X	PLL1 charge pump control	R/W	-	x2	0
Bit 2	PLL1_CP_1X	PLL1 charge pump control	R/W	-	x1	1
Bit 1	PLL1_CP_/24	PLL1 charge pump control	R/W	-	/24	1
Bit 0	PLL1_CP_/3	PLL1 charge pump control	R/W	-	/3	0

Byte 12: PLL1 Spread Spectrum Control

Byte 0Ch	Name	Control Function	Type	0	1	PWD
Bit 7	PLL1_SS_REFDIV23	PLL1 Spread Spectrum control - Ref divider 23	R/W	-	-	0
Bit 6	PLL1_SS_REFDIV[6]	PLL1 Spread Spectrum control - Ref divider 6	R/W	-	-	0
Bit 5	PLL1_SS_REFDIV[5]	PLL1 Spread Spectrum control - Ref divider 5	R/W	-	-	0
Bit 4	PLL1_SS_REFDIV[4]	PLL1 Spread Spectrum control - Ref divider 4	R/W	-	-	0
Bit 3	PLL1_SS_REFDIV[3]	PLL1 Spread Spectrum control - Ref divider 3	R/W	-	-	0
Bit 2	PLL1_SS_REFDIV[2]	PLL1 Spread Spectrum control - Ref divider 2	R/W	-	-	0
Bit 1	PLL1_SS_REFDIV[1]	PLL1 Spread Spectrum control - Ref divider 1	R/W	-	-	0
Bit 0	PLL1_SS_REFDIV[0]	PLL1 Spread Spectrum control - Ref divider 0	R/W	-	-	0

Byte 13: PLL1 Spread Spectrum Control

Byte 0Dh	Name	Control Function	Type	0	1	PWD
Bit 7	PLL1_SS_FBDIV[7]	PLL1 Spread Spectrum - feedback divider 7	R/W	-	-	0
Bit 6	PLL1_SS_FBDIV[6]	PLL1 Spread Spectrum - feedback divider 6	R/W	-	-	0
Bit 5	PLL1_SS_FBDIV[5]	PLL1 Spread Spectrum - feedback divider 5	R/W	-	-	0
Bit 4	PLL1_SS_FBDIV[4]	PLL1 Spread Spectrum - feedback divider 4	R/W	-	-	0
Bit 3	PLL1_SS_FBDIV[3]	PLL1 Spread Spectrum - feedback divider 3	R/W	-	-	0
Bit 2	PLL1_SS_FBDIV[2]	PLL1 Spread Spectrum - feedback divider 2	R/W	-	-	0
Bit 1	PLL1_SS_FBDIV[1]	PLL1 Spread Spectrum - feedback divider 1	R/W	-	-	0
Bit 0	PLL1_SS_FBDIV[0]	PLL1 Spread Spectrum - feedback divider 0	R/W	-	-	0

Byte 14: PLL1 Spread Spectrum Control

Byte 0Eh	Name	Control Function	Type	0	1	PWD
Bit 7	PLL1_SS_FBDIV[15]	PLL1 Spread Spectrum - feedback divider 15	R/W	-	-	0
Bit 6	PLL1_SS_FBDIV[14]	PLL1 Spread Spectrum - feedback divider 14	R/W	-	-	0
Bit 5	PLL1_SS_FBDIV[13]	PLL1 Spread Spectrum - feedback divider 13	R/W	-	-	0
Bit 4	PLL1_SS_FBDIV[12]	PLL1 Spread Spectrum - feedback divider 12	R/W	-	-	0
Bit 3	PLL1_SS_FBDIV[11]	PLL1 Spread Spectrum - feedback divider 11	R/W	-	-	0
Bit 2	PLL1_SS_FBDIV[10]	PLL1 Spread Spectrum - feedback divider 10	R/W	-	-	0
Bit 1	PLL1_SS_FBDIV[09]	PLL1 Spread Spectrum - feedback divider 9	R/W	-	-	0
Bit 0	PLL1_SS_FBDIV[08]	PLL1 Spread Spectrum - feedback divider 8	R/W	-	-	0

Byte 15: Output Divider1 Control

Byte 0Fh	Name	Control Function	Type	0	1	PWD
Bit 7	OUTDIV1[3]	Output divider1 control bit 3	R/W	-	-	0
Bit 6	OUTDIV1[2]	Output divider1 control bit 2	R/W	-	-	0
Bit 5	OUTDIV1[1]	Output divider1 control bit 1	R/W	-	-	1
Bit 4	OUTDIV1[0]	Output divider1 control bit 0	R/W	-	-	1
Bit 3	OUTDIV2[3]	Output divider2 control bit 3	R/W	-	-	0
Bit 2	OUTDIV2[2]	Output divider2 control bit 2	R/W	-	-	0
Bit 1	OUTDIV2[1]	Output divider2 control bit 1	R/W	-	-	1
Bit 0	OUTDIV2[0]	Output divider2 control bit 0	R/W	-	-	1

Byte 16: PLL2 Integer Feedback Divide

Byte 10h	Name	Control Function	Type	0	1	PWD
Bit 7	Reserved					0
Bit 6	Reserved					0
Bit 5	Reserved					0
Bit 4	Reserved					0
Bit 3	Reserved					0
Bit 2	PLL2_FB_INT[10]	PLL2 feedback integer divider 10	R/W	-	-	0
Bit 1	PLL2_FB_INT[9]	PLL2 feedback integer divider 9	R/W	-	-	0
Bit 0	PLL2_FB_INT[8]	PLL2 feedback integer divider 8	R/W	-	-	0

Byte 17: PLL2 Integer Feedback Divider

Byte 11h	Name	Control Function	Type	0	1	PWD
Bit 7	PLL2_FB_INT_DIV[7]	PLL2 feedback integer divider 7	R/W	-	-	0
Bit 6	PLL2_FB_INT_DIV[6]	PLL2 feedback integer divider 6	R/W	-	-	0
Bit 5	PLL2_FB_INT_DIV[5]	PLL2 feedback integer divider 5	R/W	-	-	1
Bit 4	PLL2_FB_INT_DIV[4]	PLL2 feedback integer divider 4	R/W	-	-	0
Bit 3	PLL2_FB_INT_DIV[3]	PLL2 feedback integer divider 3	R/W	-	-	1
Bit 2	PLL2_FB_INT_DIV[2]	PLL2 feedback integer divider 2	R/W	-	-	0
Bit 1	PLL2_FB_INT_DIV[1]	PLL2 feedback integer divider 1	R/W	-	-	0
Bit 0	PLL2_FB_INT_DIV[0]	PLL2 feedback integer divider 0	R/W	-	-	0

Byte 18: PLL2 Fractional Feedback Divider

Byte 12h	Name	Control Function	Type	0	1	PWD
Bit 7	PLL2_FB_FRC_DIV[7]	PLL2 feedback fractional divider 7	R/W	—	—	0
Bit 6	PLL2_FB_FRC_DIV[6]	PLL2 feedback fractional divider 6	R/W	-	-	0
Bit 5	PLL2_FB_FRC_DIV[5]	PLL2 feedback fractional divider 5	R/W	-	-	0
Bit 4	PLL2_FB_FRC_DIV[4]	PLL2 feedback fractional divider 4	R/W	-	-	0
Bit 3	PLL2_FB_FRC_DIV[3]	PLL2 feedback fractional divider 3	R/W	-	-	0
Bit 2	PLL2_FB_FRC_DIV[2]	PLL2 feedback fractional divider 2	R/W	-	-	0
Bit 1	PLL2_FB_FRC_DIV[1]	PLL2 feedback fractional divider 1	R/W	-	-	0
Bit 0	PLL2_FB_FRC_DIV[0]	PLL2 feedback fractional divider 0	R/W	-	-	0

Byte 19: PLL2 Fractional Feedback Divider

Byte 13h	Name	Control Function	Type	0	1	PWD
Bit 7	PLL2_FB_FRC_DIV[15]	PLL2 feedback fractional divider 15	R/W	-	-	0
Bit 6	PLL2_FB_FRC_DIV[14]	PLL2 feedback fractional divider 14	R/W	-	-	0
Bit 5	PLL2_FB_FRC_DIV[13]	PLL2 feedback fractional divider 13	R/W	-	-	0
Bit 4	PLL2_FB_FRC_DIV[12]	PLL2 feedback fractional divider 12	R/W	-	-	0
Bit 3	PLL2_FB_FRC_DIV[11]	PLL2 feedback fractional divider 11	R/W	-	-	0
Bit 2	PLL2_FB_FRC_DIV[10]	PLL2 feedback fractional divider 10	R/W	-	-	0
Bit 1	PLL2_FB_FRC_DIV[9]	PLL2 feedback fractional divider 9	R/W	-	-	0
Bit 0	PLL2_FB_FRC_DIV[8]	PLL2 feedback fractional divider 8	R/W	-	-	0

Byte 20: PLL2 Spread Spectrum Control

Byte 14h	Name	Control Function	Type	0	1	PWD
Bit 7	PLL2_STEP[7]	PLL2 spread step size control bit 7	R/W	-	-	0
Bit 6	PLL2_STEP[6]	PLL2 spread step size control bit 6	R/W	-	-	0
Bit 5	PLL2_STEP[5]	PLL2 spread step size control bit 5	R/W	-	-	0
Bit 4	PLL2_STEP[4]	PLL2 spread step size control bit 4	R/W	-	-	0
Bit 3	PLL2_STEP[3]	PLL2 spread step size control bit 3	R/W	-	-	0
Bit 2	PLL2_STEP[2]	PLL2 spread step size control bit 2	R/W	-	-	0
Bit 1	PLL2_STEP[1]	PLL2 spread step size control bit 1	R/W	-	-	0
Bit 0	PLL2_STEP[0]	PLL2 spread step size control bit 0	R/W	-	-	0

Byte 21: PLL2 Spread Spectrum Control

Byte 15h	Name	Control Function	Type	0	1	PWD
Bit 7	PLL2_STEP[15]	PLL2 spread step size control bit 15	R/W	-	-	0
Bit 6	PLL2_STEP[14]	PLL2 spread step size control bit 14	R/W	-	-	0
Bit 5	PLL2_STEP[13]	PLL2 spread step size control bit 13	R/W	-	-	0
Bit 4	PLL2_STEP[12]	PLL2 spread step size control bit 12	R/W	-	-	0
Bit 3	PLL2_STEP[11]	PLL2 spread step size control bit 11	R/W	-	-	0
Bit 2	PLL2_STEP[10]	PLL2 spread step size control bit 10	R/W	-	-	0
Bit 1	PLL2_STEP[9]	PLL2 spread step size control bit 9	R/W	-	-	0
Bit 0	PLL2_STEP[8]	PLL2 spread step size control bit 8	R/W	-	-	0

Byte 22: PLL2 Spread Spectrum Control

Byte 16h	Name	Control Function	Type	0	1	PWD
Bit 7	PLL2_STEP_DELTA[7]	PLL2 spread step size control delta bit 7	R/W	-	-	0
Bit 6	PLL2_STEP_DELTA[6]	PLL2 spread step size control delta bit 6	R/W	-	-	0
Bit 5	PLL2_STEP_DELTA[5]	PLL2 spread step size control delta bit 5	R/W	-	-	0
Bit 4	PLL2_STEP_DELTA[4]	PLL2 spread step size control delta bit 4	R/W	-	-	0
Bit 3	PLL2_STEP_DELTA[3]	PLL2 spread step size control delta bit 3	R/W	-	-	0
Bit 2	PLL2_STEP_DELTA[2]	PLL2 spread step size control delta bit 2	R/W	-	-	0
Bit 1	PLL2_STEP_DELTA[1]	PLL2 spread step size control delta bit 1	R/W	-	-	0
Bit 0	PLL2_STEP_DELTA[0]	PLL2 spared step size control delta bit 0	R/W	-	-	0

Byte 23: PLL2 Period Control

Byte 17h	Name	Control Function	Type	0	1	PWD
Bit 7	PLL2_PERIOD[7]	PLL2 period control bit 7	R/W	-	-	0
Bit 6	PLL2_PERIOD[6]	PLL2 period control bit 6	R/W	-	-	0
Bit 5	PLL2_PERIOD[5]	PLL2 period control bit 5	R/W	-	-	0
Bit 4	PLL2_PERIOD[4]	PLL2 period control bit 4	R/W	-	-	0
Bit 3	PLL2_PERIOD[3]	PLL2 period control bit 3	R/W	-	-	0
Bit 2	PLL2_PERIOD[2]	PLL2 period control bit 2	R/W	-	-	0
Bit 1	PLL2_PERIOD[1]	PLL2 period control bit 1	R/W	-	-	0
Bit 0	PLL2_PERIOD[0]	PLL2 period control bit 0	R/W	-	-	0

Byte 24: PLL2 Control Register

Byte 18h	Name	Control Function	Type	0	1	PWD
Bit 7	PLL2_PERIOD[9]	PLL2 period control bit 9	R/W	-	-	0
Bit 6	PLL2_PERIOD[8]	PLL2 period control bit 8	R/W	-	-	0
Bit 5	PLL2_SSEN	PLL2 spread spectrum enable	R/W	disable	enable	0
Bit 4	PLL2_R100K	PLL2 Loop filter resister 100kOhm	-	bypass	plus 100kOhm	0
Bit 3	PLL2_R50K	PLL2 Loop filter resister 50kOhm	-	bypass	plus 50kOhm	0
Bit 2	PLL2_R25K	PLL2 Loop filter resister 25kOhm	-	bypass	plus 25kOhm	0
Bit 1	PLL2_R12.5K	PLL2 Loop filter resister 12.5kOhm	-	bypass	plus 12.5kOhm	0
Bit 0	PLL2_R6K	PLL2 Loop filter resister 6kOhm	-	bypass	only 6k ohm applied	0

Byte 25: PLL2 Charge Pump Control

Byte 19h	Name	Control Function	Type	0	1	PWD
Bit 7	PLL2_CP_16X	PLL2 charge pump control	R/W	-	x16	0
Bit 6	PLL2_CP_8X	PLL2 charge pump control	R/W	-	x8	0
Bit 5	PLL2_CP_4X	PLL2 charge pump control	R/W	-	x4	1
Bit 4	PLL2_CP_2X	PLL2 charge pump control	R/W	-	x2	0
Bit 3	PLL2_CP_1X	PLL2 charge pump control	R/W	-	x1	0
Bit 2	PLL2_CP_/24	PLL2 charge pump control	R/W	-	/24	1
Bit 1	PLL2_CP_/3	PLL2 charge pump control	R/W	-	/3	0
Bit 0	PLL2_SIREF	PLL2 SiRef current selection	R/W	10µA	20µA	0

Byte 26: PLL2 M Divider Setting

Byte 1Ah	Name	Control Function	Type	0	1	PWD
Bit 7	PLL2_MDIV_Doubler	PLL2 reference divider - doubler	R/W	disable	enable	0
Bit 6	PLL2_MDIV1	PLL2 reference divider 1	R/W	disable M DIV1	bypadd divider (/1)	1
Bit 5	PLL2_MDIV2	PLL2 reference divider 2	R/W	disable M DIV2	bypadd divider (/2)	0
Bit 4	PLL2_MDIV[4]	PLL2 reference divider control bit 4	R/W	3–64, default is 25		0
Bit 3	PLL2_MDIV[3]	PLL2 reference divider control bit 3	R/W			0
Bit 2	PLL2_MDIV[2]	PLL2 reference divider control bit 2	R/W			0
Bit 1	PLL2_MDIV[1]	PLL2 reference divider control bit 1	R/W			0
Bit 0	PLL2_MDIV[0]	PLL2 reference divider control bit 0	R/W			0

Byte 27: Output Divider 4

Byte 1Bh	Name	Control Function	Type	0	1	PWD
Bit 7	OUTDIV3[3]	Out divider 4 control bit 7	R/W	-	-	0
Bit 6	OUTDIV3[2]	Out divider 4 control bit 6	R/W	-	-	0
Bit 5	OUTDIV3[1]	Out divider 4 control bit 5	R/W	-	-	1
Bit 4	OUTDIV3[0]	Out divider 4 control bit 4	R/W	-	-	1
Bit 3	OUTDIV4[3]	Out divider 4 control bit 3	R/W	-	-	0
Bit 2	OUTDIV4[2]	Out divider 4 control bit 2	R/W	-	-	0
Bit 1	OUTDIV4[1]	Out divider 4 control bit 1	R/W	-	-	1
Bit 0	OUTDIV4[0]	Out divider 4 control bit 0	R/W	-	-	1

Byte 28: PLL Operation Control Register

Byte 1Ch	Name	Control Function	Type	0	1	PWD
Bit 7	PLL2_HRS_EN	PLL2 spread high resolution selection enable	R/W	normal	enable (shift 4 bits)	0
Bit 6	PLL2_refin_sel	PLL2 reference clock source select	R/W	Xtal	DIV2	0
Bit 5	PLL3_PDB	PLL3 Power Down	R/W	Power Down	running	1
Bit 4	PLL3_LCKBYPSSB	PLL3 lock bypass	R/W	bypass lock	lock	1
Bit 3	PLL2_PDB	PLL2 Power Down	R/W	Power Down	running	1
Bit 2	PLL2_LCKBYPSSB	PLL2 lock bypass	R/W	bypass lock	lock	1
Bit 1	PLL1_PDB	PLL1 Power Down	R/W	Power Down	running	1
Bit 0	PLL1_LCKBYPSSB	PLL1 lock bypass	R/W	bypass lock	lock	1

Byte 29: Output Control

Byte 1Dh	Name	Control Function	Type	0	1	PWD
Bit 7	DIFF1_SEL	Differential clock 1 output OE2 control		not controlled	controlled	0
Bit 6	DIFF2_SEL	Differential clock 2 output OE2 control		not controlled	controlled	0
Bit 5	DIFF1_EN	Differential clock 1 output enable	R/W	disable	enable	1
Bit 4	DIFF2_EN	Differential clock 2 output enable	R/W	disable	enable	1
Bit 3	OUTDIV4_Source	Output divider 4 source clock selection	R/W	PLL2	Xtal	0
Bit 2	SE1_SLEW	SE 1 slew rate control	R/W	normal	strong	0
Bit 1	VDD1_SEL[1]	VDD1 level control bit 1	R/W	00/01: 3.3V 10: 2.5V 11: 1.8		0
Bit 0	VDD1_SEL[0]	VDD1 level control bit 0	R/W			0

Byte 30: OE and DFC Control

Byte 1Eh	Name	Control Function	Type	0	1	PWD
Bit 7	SE1_EN	SE1 output enable control	R/W	disable	enable	1
Bit 6	OE1_fun_sel[1]	OE1 pin function selection bit 1	R/W	11:DFC0 01: PD#	10: SE1_PPS 00: SE1 OE	0
Bit 5	OE1_fun_sel[0]	OE1 pin function selection bit 0	R/W			0
Bit 4	SE3_EN	SE3 output enable	R/W	disable	enable	1
Bit 3	OE3_fun_sel[1]	OE3 pin function selection bit 1	R/W	11: DFC1 01:xx	10: SE3_PPS 00:SE3_OE	0
Bit 2	OE3_fun_sel[0]	OE3 pin function selection bit 0	R/W			0
Bit 1	DFC_SW_Sel[1]	DFC frequency select bit 1	R/W	00: N0 01: N1 10:N2 11:N3		0
Bit 0	DFC_SW_Sel[0]	DFC frequency select bit 0	R/W			0

Byte 31: Control Register

Byte 1Fh	Name	Control Function	Type	0	1	PWD
Bit 7	SE2_CLKSEL1	SE2 source clock selection		DIV5	DIV4	0
Bit 6	VDD2_SEL[1]	VDD2 level control bit 1	R/W	00/01: 3.3V 10: 2.5V 11: 1.8		0
Bit 5	VDD2_SEL[0]	VDD2 level control bit 0	R/W			0
Bit 4	SE2_SLEW	SE 2 slew rate control	R/W	normal	strong	0
Bit 3	PLL2_3rd_EN_CFG	PLL2 3rd order control		1st order	3rd order	1
Bit 2	PLL2_EN_CH2	PLL2 channel 2 enable control	R/W	disable	enable	0
Bit 1	PLL2_EN_3rdpole	PLL2 3rd Pole control	R/W	disable	enable	1
Bit 0	SE2_CLKSEL1	SE2 source clock selection		DIV5	DIV4	0

Byte 32: Control Register

Byte 20h	Name	Control Function	Type	0	1	PWD
Bit 7	SE2_EN	SE2 output enable	R/W	disable	enable	1
Bit 6	OE2_fun_sel[1]	OE2 pin function selection bit 1	R/W	11: RESET 01: DIFF1/2 OE	10: SE2_PPS 00: SE2 OE	0
Bit 5	OE2_fun_sel[0]	OE2 pin function selection bit 0	R/W			0
Bit 4	DFC_EN	DFC function control	R/W	disable	enable	0
Bit 3	WD_EN	WatchDog timer control	R/W	disable	enable	0
Bit 2	Timer_sel<1>	Watchdog timer select bit 1	R/W	00: 250ms 01: 500ms 10: 2s 11: 4s		0
Bit 1	Timer_sel<0>	Watchdog timer select bit 0	R/W			0
Bit 0	Alarm_Flag	Alarm Status (Read Only)	R	No alarm	Alarmed	0

Byte 33: SE3 and DIFF1 Control Register

Byte 21h	Name	Control Function	Type	0	1	PWD
Bit 7	SE3_Freerun_32K	SE3 32K free run	R/W	freerun 32K	DIV2 or DIV4 selected by B33bit6	1
Bit 6	SE3_CLKSEL1	SE3 source clock selection	R/W	DIV2	DIV4	0
Bit 5	VDD3_SEL[1]	VDD3 level control bit 1	R/W	11: 1.8V 10: 2.5V 0x: 3.3V		0
Bit 4	VDD3_SEL[0]	VDD3 level control bit 0	R/W			0
Bit 3	SE3_SLEW	SE 3 slew rate control	R/W	normal	strong	0
Bit 2	DIFF_PDBHiZEN	Differential output high-Z at power down	R/W	TBD	output tri-state, bias off	0
Bit 1	DIFF1_CMOS2_FLIP	Differential 1/2 LVCMOS output control	R/W	DIFF1_B inverted	DIFF1_B non-inverted	0
Bit 0	DIFF2_CMOS2_FLIP	Differential 1/2 LVCMOS output control	R/W	DIFF2_B inverted	DIFF2_B non-inverted	0

Byte 34: DIFF1 Control Register

Byte 22h	Name	Control Function	Type	0	1	PWD
Bit 7	DIFF1_CLK_SEL	Differential clock 1 source selection	R/W	DIV1	DIV3	1
Bit 6	DIFF1_io_pwr_sel	Differential clock 1 output power	R/W	2.5V	3.3V	1
Bit 5	DIFF1_OUTPUT_TYPE[1]	Differential clock 1 type select bit 1	R/W	00: LVCMOS 01: LVDS 10: LVPECL 11: LP-HCSL		1
Bit 4	DIFF1_OUTPUT_TYPE[0]	Differential clock 1 type select bit 0	R/W			1
Bit 3	DIFF1_AMP[1]	Differential clock 1 amplitude control bit 1	R/W	LP-HCSL: 00 = 740mV, 01 = 800mV, 10 = 855mV, 11 = 910mV LPECL: 00 = 710mV, 01 = 810mV, 10 = 875mV, 11 = 920mV LVDS: 00 = 311mV, 01 = 344mV, 10 = 376mV, 11 = 408mV		0
Bit 2	DIFF1_AMP[0]	Differential clock 1 amplitude control bit 0	R/W			1
Bit 1	DIFF1_CMOS_SLEW	Differential clock 1 LVCMOS slew rate control	R/W	normal	strong	0
Bit 0	D1FF1_CMOS2_EN	Differential clock 1 LVCMOS output_B control	R/W	disable	enable	0

Byte 35: DIFF2 Control Register

Byte 23h	Name	Control Function	Type	0	1	PWD
Bit 7	DIFF2_CLK_SEL	Differential clock 2 source selection	R/W	DIV1	DIV3	0
Bit 6	DIFF2_IO_PWR_SEL	Differential clock 2 output power	R/W	2.5V	3.3V	1
Bit 5	DIFF2_OUTPUT_TYPE[1]	Differential clock 2 type select bit 1	R/W	00: LVCMOS 01: LVDS 10: LVPECL 11: LP-HCSL		1
Bit 4	DIFF2_OUTPUT_TYPE[0]	Differential clock 2 type select bit 0	R/W			1
Bit 3	DIFF2_AMP[1]	Differential clock 2 amplitude control bit 1	R/W	LP-HCSL: 00 = 740mV, 01 = 800mV, 10 = 855mV, 11 = 910mV LPECL:00 = 710mV, 01 = 810mV, 10 = 875mV, 11 = 920mV LVDS:00 = 311mV, 01 = 344mV, 10 = 376mV, 11 = 408mV		0
Bit 2	DIFF2_AMP[0]	Differential clock 2 amplitude control bit 0	R/W			1
Bit 1	DIFF2_CMOS_SLEW	Differential clock 2 LVCMOS slew rate control	R/W	normal	strong	0
Bit 0	DIFF2_CMOS2_EN	Differential clock 2 LVCMOS output_B control	R/W	disable	enable	0

Byte 36: SE1 and DIV4 control

Byte 24h	Name	Control Function	Type	0	1	PWD
Bit 7	I2C_PDB	chip power down control bit	R/W	power down	normal	1
Bit 6	Ref_free_run	Reference clock output (SE2/SE3)	R/W	stop	freerun	0
Bit 5	free_run_output_config	SE clocks free run control	R/W	SE2 free run	SE2/3 free run	0
Bit 4	SE1_Freerun_32K	SE1 clock output default	R/W	32K freerun	B36bit3 control	0
Bit 3	SE1_CLKSEL1	SEL1 output select	R/W	DIV5	DIV4	1
Bit 2	REF_EN	REF output enable	R/W	disable	enable	1
Bit 1	DIV4_CH3_EN	DIV4 channel 3 output control	R/W	disable	enable	0
Bit 0	DIV4_CH2_EN	DIV4 channel 3 output control	R/W	disable	enable	0

Package Outline Drawings

The package outline drawings are located at the end of this document and are accessible from the Renesas website (see [Ordering Information](#) for POD links). The package information is the most current data available and is subject to change without revision of this document.

Marking Diagrams

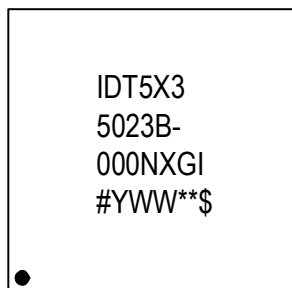
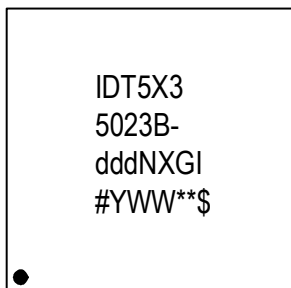

- Lines 1, 2, and 3: part number.
- Line 4:
 - “#” denotes the stepping.
 - “YWW” is the last digit of the year and work week that the part was assembled.
 - “***” denotes the lot sequence number.
 - “\$” denotes the assembler mark code.

Ordering Information

Part Number	Package	Carrier Type	Temperature Range
5X35023B-dddNXGI	4 × 4 mm, 0.5mm pitch 24-VFQFPN	Tray	-40° to +85°C
5X35023B-dddNXGI8	4 × 4 mm, 0.5mm pitch 24-VFQFPN	Reel	-40° to +85°C
5X35023B-000NXGI	4 × 4 mm, 0.5mm pitch 24-VFQFPN	Tray	-40° to +85°C
5X35023B-000NXGI8	4 × 4 mm, 0.5mm pitch 24-VFQFPN	Reel	-40° to +85°C

¹ “ddd” denotes factory programmed configurations based on required settings. Contact factory for programming configurations.

² “000” denotes unprogrammed part for customization.

Revision History

Date	Description of Change
March 14, 2024	Changed Features bullet on page 1 to “Integrated 25MHz crystal” from “Integrated crystal”.
June 22, 2023	Added crystal frequency stability information to Table 22 .
October 28, 2019	<ul style="list-style-type: none"> ▪ Updated Supply Voltage to 3.465V. ▪ Updated typical values in Input Capacitance, LVCMOS Output Impedance, and Internal Pull-down table. ▪ Updated all DC Electrical Characteristics tables. ▪ Updated notes column in DIF 0.7V LP-HCSL Differential Outputs table. ▪ Updated Power Consumption of 32.768kHz Output Only Operation table; moved Maximum values to Typical column. ▪ Updated AC Electrical Characteristics table. ▪ Updated Spread Spectrum Generation Specification table. ▪ Updated PPS Assertion/Deassertion Timing Chart diagram. ▪ Updated orderable part numbers to revision “B”. ▪ Updated marking diagrams and notes. ▪ Removed note “VBAT should be powered earlier or at same time with other VDD power up. Connecting with a coin cell battery is suggested.”
May 2, 2018	Initial release.

DATE		REVISIONS	
CREATED	REV	DESCRIPTION	AUTHOR
4/6/17	00	INITIAL RELEASE	JH
4/12/17	01	CLEAN UP POD & CHANGE PACKAGE THICKNESS	JH
7/6/17	02	CORRECT "K" VALUE	JH
6/15/18	03	CHANGE QFN TO VFQFPN REMOVE TABLE DIMENSION	RC

NOTE: REFER TO DCP FOR OFFICIAL RELEASE DATE

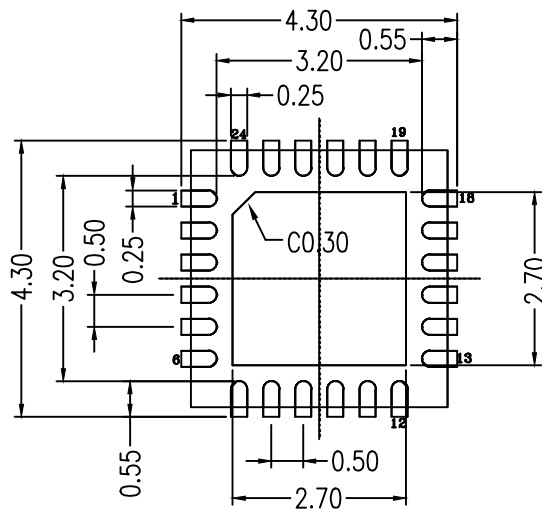

RECOMMENDED LAND PATTERN DIMENSION

NOTES:

1. ALL DIMENSIONS ARE IN MM. ANGLES IN DEGREES.
2. TOP DOWN VIEW, AS VIEWED ON PCB.
3. LAND PATTERN RECOMMENDATION PER IPC-7351B GENERIC REQUIREMENT FOR SURFACE MOUNT DESIGN AND LAND PATTERN.

TOLERANCES UNLESS SPECIFIED		 6024 Silver Creek Valley Road San Jose, CA 95138 PHONE: (408) 284-8200 www.IDT.com FAX: (408) 284-8591	
DECIMAL	ANGULAR		
XX±	±		
XXX±			
XXXX±			
TITLE		NXG24 Package Outline Drawing	
		4.0 x 4.0 x 1.5 mm Body Epad 2.70 x 2.70 mm	
		0.5mm Pitch VFQFPN	
SIZE	DRAWING No.	REV	
C	PSC-4631	03	
DO NOT SCALE DRAWING			SHEET 2 OF 2

IMPORTANT NOTICE AND DISCLAIMER

RENESAS ELECTRONICS CORPORATION AND ITS SUBSIDIARIES (“RENESAS”) PROVIDES TECHNICAL SPECIFICATIONS AND RELIABILITY DATA (INCLUDING DATASHEETS), DESIGN RESOURCES (INCLUDING REFERENCE DESIGNS), APPLICATION OR OTHER DESIGN ADVICE, WEB TOOLS, SAFETY INFORMATION, AND OTHER RESOURCES “AS IS” AND WITH ALL FAULTS, AND DISCLAIMS ALL WARRANTIES, EXPRESS OR IMPLIED, INCLUDING, WITHOUT LIMITATION, ANY IMPLIED WARRANTIES OF MERCHANTABILITY, FITNESS FOR A PARTICULAR PURPOSE, OR NON-INFRINGEMENT OF THIRD-PARTY INTELLECTUAL PROPERTY RIGHTS.

These resources are intended for developers who are designing with Renesas products. You are solely responsible for (1) selecting the appropriate products for your application, (2) designing, validating, and testing your application, and (3) ensuring your application meets applicable standards, and any other safety, security, or other requirements. These resources are subject to change without notice. Renesas grants you permission to use these resources only to develop an application that uses Renesas products. Other reproduction or use of these resources is strictly prohibited. No license is granted to any other Renesas intellectual property or to any third-party intellectual property. Renesas disclaims responsibility for, and you will fully indemnify Renesas and its representatives against, any claims, damages, costs, losses, or liabilities arising from your use of these resources. Renesas' products are provided only subject to Renesas' Terms and Conditions of Sale or other applicable terms agreed to in writing. No use of any Renesas resources expands or otherwise alters any applicable warranties or warranty disclaimers for these products.

(Disclaimer Rev.1.01 Jan 2024)

Corporate Headquarters

TOYOSU FORESIA, 3-2-24 Toyosu,
Koto-ku, Tokyo 135-0061, Japan
www.renesas.com

Trademarks

Renesas and the Renesas logo are trademarks of Renesas Electronics Corporation. All trademarks and registered trademarks are the property of their respective owners.

Contact Information

For further information on a product, technology, the most up-to-date version of a document, or your nearest sales office, please visit www.renesas.com/contact-us/.