

## 8P34S2108-1

Dual 1:8 LVDS Output 1.8V / 2.5V Fanout Buffer with OE/Swing Control

The 8P34S2108-1 is a differential dual 1:8 LVDS output 1.8V/2.5V fanout buffer that boasts high performance and low power consumption. It is engineered to support fail-safe operation and specifically designed for the fanout of high-frequency clock and data signals with very low additive phase-noise. The device comprises two independent buffer channels, and each of these channels has eight outputs with low skew. High isolation between the channels ensures minimal noise coupling.

The 8P34S2108-1 shines in clock distribution applications that require well-defined performance and repeatability due to its guaranteed output-to-output and part-to-part skew characteristics. The device can operate using a 1.8V or 2.5V power supply. Its integrated bias voltage references allow for the easy interfacing of AC-coupled signals with the device's inputs.

The 8P34S2108-1 has the individual OE / Swing control pin for each output, which provides the excellent control over both swing and output enable functions.

### Features

- Dual 1:8 low skew, low additive jitter LVDS fanout buffers
- Individual OE / swing control pin for each output.
- Matched AC characteristics across both channels
- High isolation between channels
- Both differential CLKA, nCLKA and CLKB, nCLKB inputs accept LVDS, LVPECL, and single-ended LVCMOS levels
- Maximum input clock frequency of 2GHz
- Output amplitudes: 350mV, 500mV, or disable (selectable)
- Output skew: 20ps typical
- Low additive phase jitter, RMS: 50fs typical ( $f_{REF} = 156.25\text{MHz}$ , 12kHz–20MHz)
- Full 1.8V and 2.5V supply voltage mode
- Lead-free (RoHS 6), 64-lead VFQFPN packaging
- -40°C to +85°C ambient operating temperature
- Supports case temperature up to +105°C

### Applications

- 4G and 5G RU and DU system
- Ethernet switches / routers
- Medical imaging
- Professional audio and video
- Data center and server

## Contents

<b>1. Overview</b>	<b>3</b>
1.1 Block Diagram	3
<b>2. Pin Information</b>	<b>4</b>
2.1 Pin Assignments	4
2.2 Pin Descriptions	4
2.3 OE Output Amplitude Selection (Static Control)	6
<b>3. Specifications</b>	<b>7</b>
3.1 Absolute Maximum Ratings	7
3.2 Recommended Operating Conditions	7
3.3 Thermal Specifications	7
3.4 DC Input Characteristics	8
3.5 Power Supply DC Characteristics	8
3.6 Power Supply DC Characteristics	8
3.7 LVCMOS/LVTTL Input DC Characteristics	8
3.8 Differential Input Characteristics	9
3.9 LVDS AC and DC Characteristics	9
3.10 AC Characteristics	10
<b>4. Additive Phase Jitter</b>	<b>11</b>
<b>5. Applications Information</b>	<b>12</b>
5.1 Fail-Safe Operation	12
5.2 Recommendations for Unused Input and Output Pins	12
5.2.1 Inputs	12
5.2.2 Outputs	12
5.3 Wiring the Differential Input to Accept Single-Ended Levels	12
5.4 1.8V Differential Clock Input Interface	13
5.5 LVDS Driver Termination	14
<b>6. Package Outline Drawings</b>	<b>15</b>
<b>7. Marking Diagram</b>	<b>15</b>
<b>8. Ordering Information</b>	<b>15</b>
<b>9. Revision History</b>	<b>16</b>

# 1. Overview

## 1.1 Block Diagram

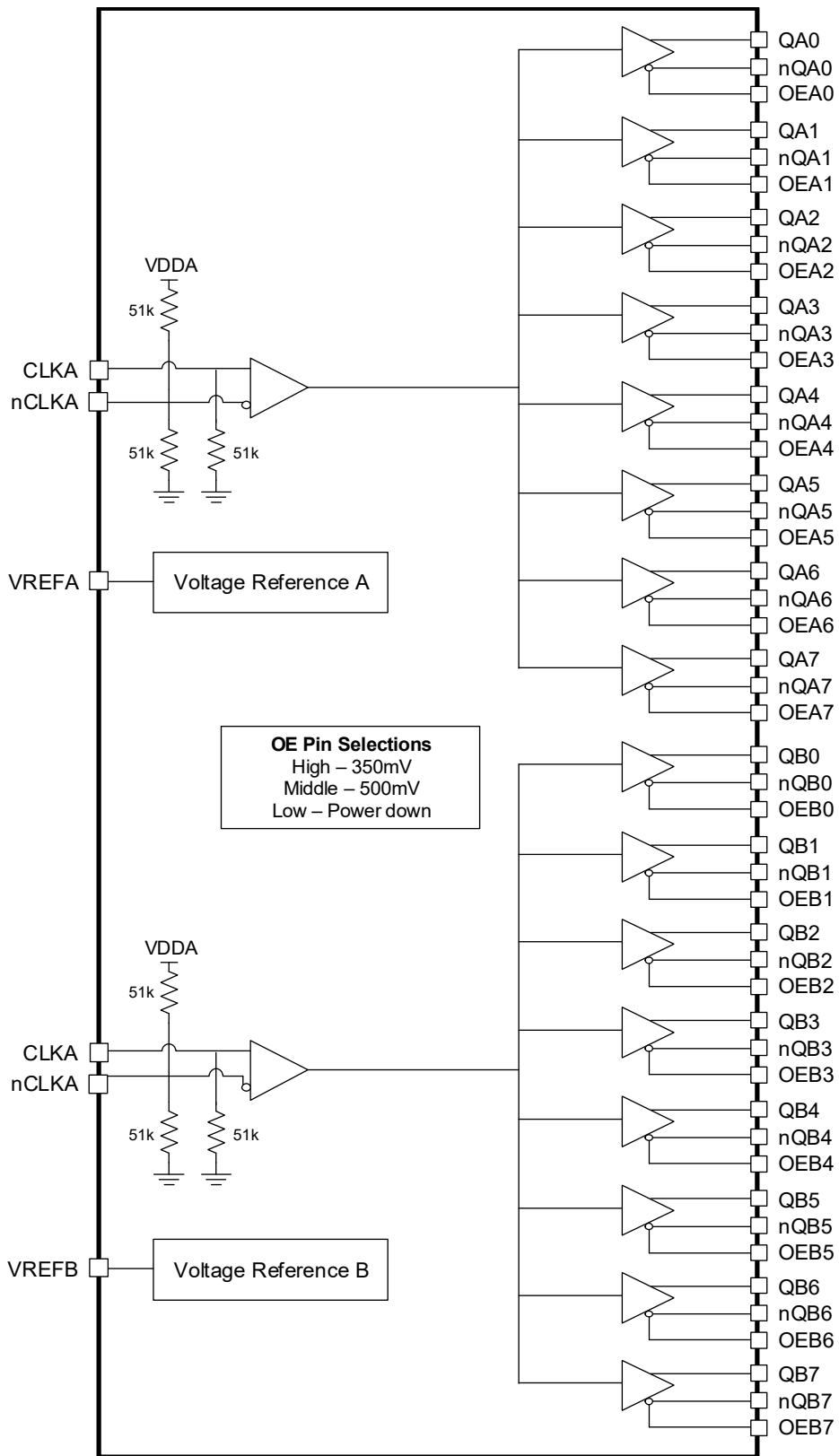

Figure 1. Block Diagram

## 2. Pin Information

### 2.1 Pin Assignments

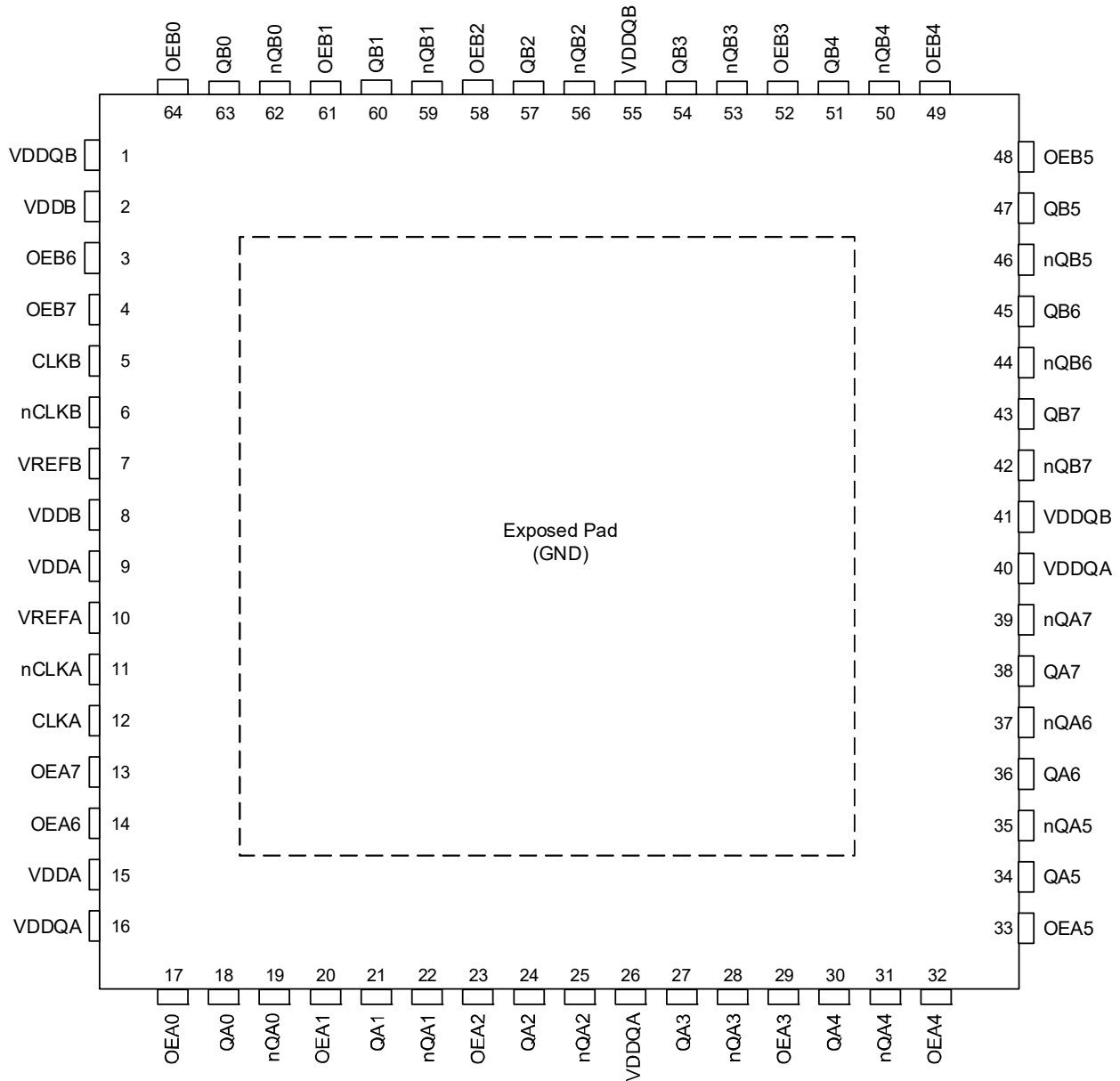

Figure 2. Pin Assignments – Top View

### 2.2 Pin Descriptions

Table 1. Pin Descriptions

Pin Number	Pin Name	Type	Description
1	VDDQB	Power	Power supply pin for the channel B outputs QB[0:7].
2	VDDDB	Power	Power supply pins for the core and inputs of channel B.
3	OEB6	Input	Control output enables and swing for QB6. LVCMOS/TTL input levels.
4	OEB7	Input	Control output enables and swing for QB7. LVCMOS/TTL input levels.

Table 1. Pin Descriptions (Cont.)

Pin Number	Pin Name	Type	Description
5	CLKB	Input (PD)	Non-inverting differential clock/data input for channel B.
6	nCLKB	Input (PD/PU)	Inverting differential clock/data input for channel B.
7	VREFB	Power	Bias voltage reference for the CLKB, nCLKB input pairs.
8	VDDDB	Power	Power supply pins for the core and inputs of channel B.
9	VDDA	Power	Power supply pins for the core and inputs of channel A.
10	VREFA	Power	Bias voltage reference for the CLKA, nCLKA input pairs.
11	nCLKA	Input (PD/PU)	Inverting differential clock/data input for channel A.
12	CLKA	Input (PD)	Non-inverting differential clock/data input for channel A.
13	OEA7	Input	Control output enables and swing for QA7. LVCMOS/TTL input levels.
14	OEA6	Input	Control output enables and swing for QA6. LVCMOS/TTL input levels.
15	VDDA	Power	Power supply pins for the core and inputs of channel A.
16	VDDQA	Power	Power supply pin for the channel A outputs QA[0:7].
17	OEA0	Input	Control output enables and swing for QA0. LVCMOS/TTL input levels.
18	QA0	Output	Differential output pair A0. LVDS interface levels.
19	nQA0	Output	Differential output pair A0. LVDS interface levels.
20	OEA1	Input	Control output enables and swing for QA1. LVCMOS/TTL input levels.
21	QA1	Output	Differential output pair A1. LVDS interface levels.
22	nQA1	Output	Differential output pair A1. LVDS interface levels.
23	OEA2	Input	Control output enables and swing for QA2. LVCMOS/TTL input levels.
24	QA2	Output	Differential output pair A2. LVDS interface levels.
25	nQA2	Output	Differential output pair A2. LVDS interface levels.
26	VDDQA	Power	Power supply pin for the channel A outputs QA[0:7].
27	QA3	Output	Differential output pair A3. LVDS interface levels.
28	nQA3	Output	Differential output pair A3. LVDS interface levels.
29	OEA3	Input	Control output enables and swing for QA3. LVCMOS/TTL input levels.
30	QA4	Output	Differential output pair A4. LVDS interface levels.
31	nQA4	Output	Differential output pair A4. LVDS interface levels.
32	OEA4	Input	Control output enables and swing for QA4. LVCMOS/TTL input levels.
33	OEA5	Input	Control output enables and swing for QA5. LVCMOS/TTL input levels.
34	QA5	Output	Differential output pair A5. LVDS interface levels.
35	nQA5	Output	Differential output pair A5. LVDS interface levels.
36	QA6	Output	Differential output pair A6. LVDS interface levels.
37	nQA6	Output	Differential output pair A6. LVDS interface levels.
38	QA7	Output	Differential output pair A7. LVDS interface levels.
39	nQA7	Output	Differential output pair A7. LVDS interface levels.
40	VDDQA	Power	Power supply pin for the channel A outputs QA[0:7].
41	VDDQB	Power	Power supply pin for the channel B outputs QB[0:7].

Table 1. Pin Descriptions (Cont.)

Pin Number	Pin Name	Type	Description
42	nQB7	Output	Differential output pair B7. LVDS interface levels.
43	QB7	Output	Differential output pair B7. LVDS interface levels.
44	nQB6	Output	Differential output pair B6. LVDS interface levels.
45	QB6	Output	Differential output pair B6. LVDS interface levels.
46	nQB5	Output	Differential output pair B5. LVDS interface levels.
47	QB5	Output	Differential output pair B5. LVDS interface levels.
48	OEB5	Input	Control output enables and swing for QB5. LVCMOS/TTL input levels.
49	OEB4	Input	Control output enables and swing for QB4. LVCMOS/TTL input levels.
50	nQB4	Output	Differential output pair B4. LVDS interface levels.
51	QB4	Output	Differential output pair B4. LVDS interface levels.
52	OEB3	Input	Control output enables and swing for QB3. LVCMOS/TTL input levels.
53	nQB3	Output	Differential output pair B3. LVDS interface levels.
54	QB3	Output	Differential output pair B3. LVDS interface levels.
55	VDDQB	Power	Power supply pin for the channel B outputs QB[0:7].
56	nQB2	Output	Differential output pair B2. LVDS interface levels.
57	QB2	Output	Differential output pair B2. LVDS interface levels.
58	OEB2	Input	Control output enables and swing for QB2. LVCMOS/TTL input levels.
59	nQB1	Output	Differential output pair B1. LVDS interface levels.
60	QB1	Output	Differential output pair B1. LVDS interface levels.
61	OEB1	Input	Control output enables and swing for QB1. LVCMOS/TTL input levels.
62	nQB0	Output	Differential output pair B0. LVDS interface levels.
63	QB0	Output	Differential output pair B0. LVDS interface levels.
64	OEB0	Input	Control output enables and swing for QB0. LVCMOS/TTL input levels.
-	ePAD	Power	EPAD connect to GND.

## 2.3 OE Output Amplitude Selection (Static Control)

Table 2. OE Output Amplitude Selection (Static Control)

OE Pin	QA and QB Output Amplitude (mV)
1	350
Float (default)	500
0	Disable (power-down)

### 3. Specifications

#### 3.1 Absolute Maximum Ratings

**Caution:** Do not operate at or near the maximum ratings listed for extended periods of time. Exposure to such conditions can adversely impact product reliability and result in failures not covered by warranty.

Figure 3. Absolute Maximum Ratings

Parameter	Minimum	Maximum	Unit
Supply Voltage, $V_{DD}$	-	4.6	V
Input, $V_I$	-0.5	4.6	V
Input, $I_I$	-	20m	A
Outputs, $I_O$			
Continuous Current	-	10	mA
Surge Current	-	15	
Input Sink/Source, $I_{REF}$	-	$\pm 2$	mA
Maximum Junction Temperature, $T_{JMAX}$	-	125	$^{\circ}C$
Storage Temperature, $T_{STG}$	-65	150	$^{\circ}C$
ESD - Human Body Model	-	2000	V
ESD - Charged Device Model	-	1500	V

#### 3.2 Recommended Operating Conditions

Table 3. Recommended Operating Conditions [1][2]

Symbol	Parameter	Condition	Minimum	Typical	Maximum	Unit
$T_J$	Maximum Junction Temperature	-	-	-	125	$^{\circ}C$
$T_A$	Ambient Operating Temperature	-	-40	-	85	$^{\circ}C$
$V_{DDx}$	Supply Voltage with Respect to Ground	Any $V_{DD}$ pin, 1.8V supply	1.71	1.8	1.89	V
		Any $V_{DD}$ pin, 2.5V supply	2.1	2.5	2.7	V

- All electrical characteristics are specified over Recommended Operating Conditions unless noted otherwise.
- All conditions in this table must be met to guarantee device functionality and performance.

#### 3.3 Thermal Specifications

Parameter	Package	Symbol	Conditions	Typical Value	Unit
Thermal Resistance	64-VFQFPN, 9.0 × 9.0 mm	$\theta_{JA0}$	Junction to ambient, still air	22	$^{\circ}C/W$
		$\theta_{JA1}$	Junction to ambient, 1 m/s air flow	19	$^{\circ}C/W$
		$\theta_{JA2}$	Junction to ambient, 2 m/s air flow	17	$^{\circ}C/W$
		$\theta_{JB}$	Junction to board	1.4	$^{\circ}C/W$
		$\theta_{JC}$	Junction to case	12.8	$^{\circ}C/W$

### 3.4 DC Input Characteristics

Symbol	Parameter	Test Conditions	Minimum	Typical	Maximum	Unit
$C_{IN}$	Input Capacitance	-	-	2	-	pF
$R_{PULLDOWN}$	Input Pull-down Resistor	-	-	51	-	k ohms
$R_{PULLUP}$	Input Pull-up Resistor	-	-	51	-	k ohms

### 3.5 Power Supply DC Characteristics

$V_{DD} = 1.8V \pm 5\%$ ,  $T_A = -40^\circ C$  to  $85^\circ C$

Symbol	Parameter	Test Conditions	Minimum	Typical	Maximum	Unit
$V_{DD}$	Power Supply Voltage	-	1.71	1.8	1.89	V
$I_{DD}$	Power Supply Current	All QA, QB output terminated 100 ohm. Output swing is 500mV	-	404	515	mA
$I_{DD}$	Power Supply Current	All QA, QB output terminated 100 ohm. Output swing is 350mV	-	300	380	mA
$I_{DD}$	Power Supply Current	All QA, QB output disabled.	-	95	125	mA

### 3.6 Power Supply DC Characteristics

$V_{DD} = 2.1V$  to  $2.7V$ ,  $T_A = -40^\circ C$  to  $85^\circ C$

Symbol	Parameter	Test Conditions	Minimum	Typical	Maximum	Unit
$V_{DD}$	Power Supply Voltage	-	2.1	2.5	2.7	V
$I_{DD}$	Power Supply Current	All QA, QB output terminated 100 ohm. Output swing is 500mV	-	420	530	mA
$I_{DD}$	Power Supply Current	All QA, QB output terminated 100 ohm. Output swing is 350mV	-	310	390	mA
$I_{DD}$	Power Supply Current	All QA, QB output disabled.	-	113	145	mA

### 3.7 LVCMOS/LVTTL Input DC Characteristics

$V_{DD} = 1.8V \pm 5\%$ ,  $2.1V$  to  $2.7V$ ,  $T_A = -40^\circ C$  to  $85^\circ C$ .

Symbol	Parameter	Test Conditions	Minimum	Typical	Maximum	Unit
$V_{IH}$	Input High Voltage	$V_{DD} = 1.89V, 2.7V$	$0.75 \times V_{DD}$	-	$V_{DD} + 0.3$	V
$V_{IM}$	Input Middle Voltage	$V_{DD} = 1.89V, 2.7V$	$0.45 \times V_{DD}$	-	$0.55 \times V_{DD}$	V
$V_{IL}$	Input Low Voltage	$V_{DD} = 1.89V, 2.7V$	-0.3	-	$0.25 \times V_{DD}$	V
$I_{IH}$	Input High Current, OEx	$V_{DD} = V_{IN} = 1.89V, 2.7V$	-	-	150	$\mu A$
$I_{IL}$	Input Low Current, OEx	$V_{DD} = 1.89V, 2.7V$ , $V_{IN} = 0V$	-10	-	-	$\mu A$
$I_{LEAK}$	Input Leakage Current, OEx	$V_{IN} = 2.7V, V_{DD} = 0V$	-	-	250	$\mu A$



### 3.8 Differential Input Characteristics

$V_{DD} = 1.8V \pm 5\%$ , 2.1V to 2.7V,  $T_A = -40^\circ\text{C}$  to  $85^\circ\text{C}$ .

Symbol	Parameter	Test Conditions	Minimum	Typical	Maximum	Unit
$I_{IH}$	Input High Current CLKA, nCLKA; CLKB, nCLKB	$V_{DD} = V_{IN} = 1.89V, 2.7V$	-	-	150	$\mu\text{A}$
$I_{IL}$	Input Low Current CLKA, CLKB	$V_{IN} = 0V, V_{DD} = 1.89V,$ $2.7V$	-150	-	-	$\mu\text{A}$
	Input Low Current nCLKA, nCLKB	$V_{IN} = 0V, V_{DD} = 1.89V,$ $2.7V$	-150	-	-	$\mu\text{A}$
$I_{LEAK}$	Input Leakage Current	$V_{IN} = 2.7V, V_{DD} = 0V$	-	-	250	$\mu\text{A}$
$V_{REF}$	Reference Voltage for Input Bias	$I_{REF} = -100\mu\text{A};$ $V_{DD} = 1.8V, 2.5V$	$0.7 \times V_{DD}$	-	$0.85 \times V_{DD}$	V
$V_{PP}$	Peak-to-peak Voltage	$V_{DD} = 1.89V, 2.7V$	0.2	-	1	V
$V_{CMR}$	Common Mode Input Voltage	-	0.9	-	$V_{DD} - (V_{PP}/2)$	V

### 3.9 LVDS AC and DC Characteristics

$V_{DD} = 1.8V \pm 5\%$ , 2.1V to 2.7V,  $T_A = -40^\circ\text{C}$  to  $85^\circ\text{C}$ .

Symbol	Parameter [1]	Test Conditions	Minimum	Typical	Maximum	Unit
$\Delta V_{OD}$	VOD Magnitude Change	-	-	-	50	mV
$\Delta V_{OD}$	VOD Magnitude Change	-	-	-	50	mV
$V_{OD}$	Differential Output Voltage	Output = 350mV, $f_{REF} < 1.5\text{GHz}$	247	350	454	mV
		Output = 500mV, $f_{REF} < 1.5\text{GHz}$	350	500	650	mV

1. Electrical parameters are guaranteed over the specified ambient operating temperature range, which is established when the device is mounted in a test socket with maintained transverse airflow greater than 500 lfm. The device will meet specifications after thermal equilibrium has been reached under these conditions.

### 3.10 AC Characteristics

$V_{DD} = 1.8V \pm 5\%$  or 2.1 to 2.7V,  $T_A = -40^\circ\text{C}$  to  $85^\circ\text{C}$

Symbol	Parameter	Test Conditions	Minimum	Typical	Maximum	Unit	
$F_{REF}$	Input Frequency	-	0	-	2	GHz	
dV/dt	Input Edge Rate	-	1.5	-	-	V/ns	
$t_{PD}$	Propagation Delay	CLK[0:1], nCLK[0:1] to any Qx, nQx	100	300	425	ps	
tsk(o)	Output Skew	-	-	20	45	ps	
tsk(p)	Pulse Skew	$f_{REF} = 100\text{MHz}$	-	-	30	ps	
tsk(pp)	Part-to-part Skew	-	-	-	200	ps	
$t_{jit}$	Buffer Additive Phase Jitter, RMS	$f_{REF} = 122.88\text{MHz}$ Square Wave, $V_{PP} = 1V$ , Integration Range: 12kHz to 20MHz	-	50	-	fs	
		$f_{REF} = 156.25\text{MHz}$ Square Wave, $V_{PP} = 1V$ , Integration Range: 12kHz to 20MHz	-	50	-	fs	
		$f_{REF} = 156.25\text{MHz}$ Square Wave, $V_{PP} = 0.5V$ , Integration Range: 12kHz to 20MHz	-	50	-	fs	
PNF	Phase noise floor	Phase noise floor carrier frequency at 122.88MHz at 20MHz offset	-	-160	-	dBc/Hz	
$t_R / t_F$	Output Rise/ Fall Time	$V_{DD} = 1.8V \pm 5\%$ , outputs loaded with 100ohm	10% to 90%	-	150	400	ps
			20% to 80%	-	90	160	ps
		$V_{DD} = 2.1V, 2.5V, 2.7V$ , outputs loaded with 100ohm	10% to 90%	-	200	420	ps
			20% to 80%	-	110	190	ps
$MUX_{isolation}$	Mux Isolation	$f_{REF} = 100\text{MHz}$	-	80	-	dB	

## 4. Additive Phase Jitter

The spectral purity in a band at a specific offset from the fundamental compared to the power of the fundamental is called the *dBc Phase Noise*. This value is normally expressed using a phase noise plot, and is most often the specified plot in many applications. Phase noise is defined as the ratio of the noise power present in a 1Hz band at a specified offset from the fundamental frequency to the power value of the fundamental. This ratio is expressed in decibels (dBm), or a ratio of the power in the 1Hz band to the power in the fundamental. When the required offset is specified, the phase noise is called a *dBc* value, which simply means dBm at a specified offset from the fundamental. By investigating jitter in the frequency domain, we get a better understanding of its effects on the desired application over the entire time record of the signal. It is mathematically possible to calculate an expected bit error rate given a phase noise plot.

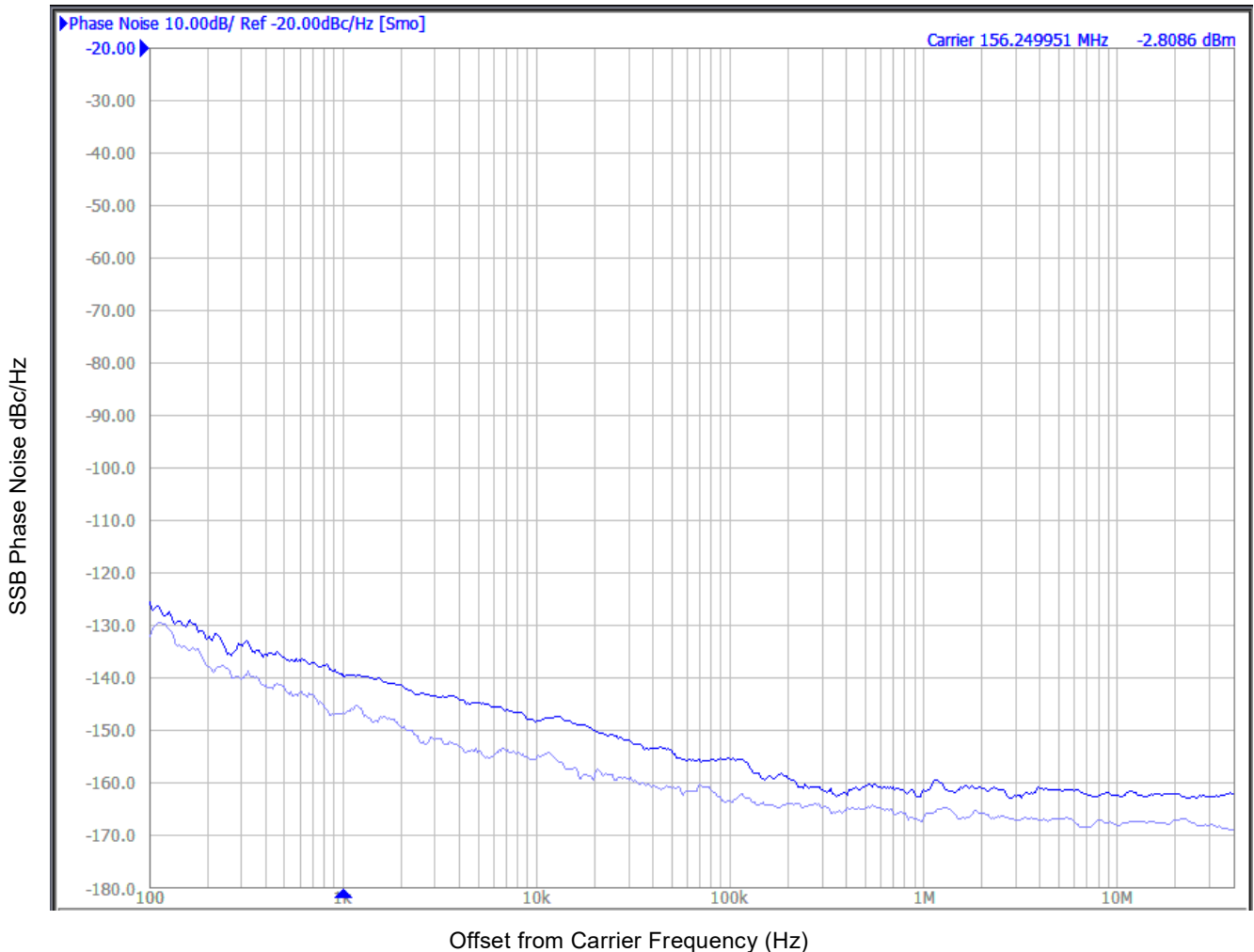

**Figure 4. Additive Phase Jitter. Frequency: 156.25MHz, Integration Range: 12kHz to 20MHz = 45fs Typical**

As with most timing specifications, phase noise measurements have issues relating to the limitations of the measurement equipment. The noise floor of the equipment can be higher or lower than the noise floor of the device. Additive phase noise is dependent on both the noise floor of the input source and measurement equipment.

*Note:* The phase noise plot was measured using a Wenzel 156.25MHz Oscillator as the input source.

## 5. Applications Information

### 5.1 Fail-Safe Operation

All clock inputs support fail-safe operation. That is, when the device is powered down, the clock inputs can be held at a DC voltage of up to 4.6V without damaging the device or the input pins.

### 5.2 Recommendations for Unused Input and Output Pins

#### 5.2.1 Inputs

##### 5.2.1.1 CLK/nCLK Inputs

For applications not requiring the use of the differential input, both CLK and nCLK can be left floating. Though not required, but for additional protection, a 1k $\Omega$  resistor can be tied from CLK to ground.

#### 5.2.2 Outputs

##### 5.2.2.1 LVDS Outputs

All unused LVDS output pairs can be either left floating or terminated with 100 $\Omega$  across. If they are left floating there should be no trace attached.

##### 5.2.2.2 VREFX

The unused VREFA and VREFB pins can be left floating. We recommend that there is no trace attached.

### 5.3 Wiring the Differential Input to Accept Single-Ended Levels

Figure 5 shows an example of how a differential input can be wired to accept single-ended levels. To satisfy the  $V_{CMR}$  requirement, the reference voltage  $V_1$  is set to 1.2V which is generated by the bias resistors  $R_1$  and  $R_2$ . The bypass capacitor ( $C_1$ ) is used to help filter noise on the DC bias. This bias circuit should be located as close to the input pin as possible. The ratio of  $R_1$  and  $R_2$  might need to be adjusted to position the  $V_1$  to meet the  $V_{CMR}$  requirement. For example, if the input clock swing is 1.8V and  $V_{DD} = 1.8V$ , the  $R_1$  and  $R_2$  values should be adjusted to set  $V_1$  at 1.2V in this example.

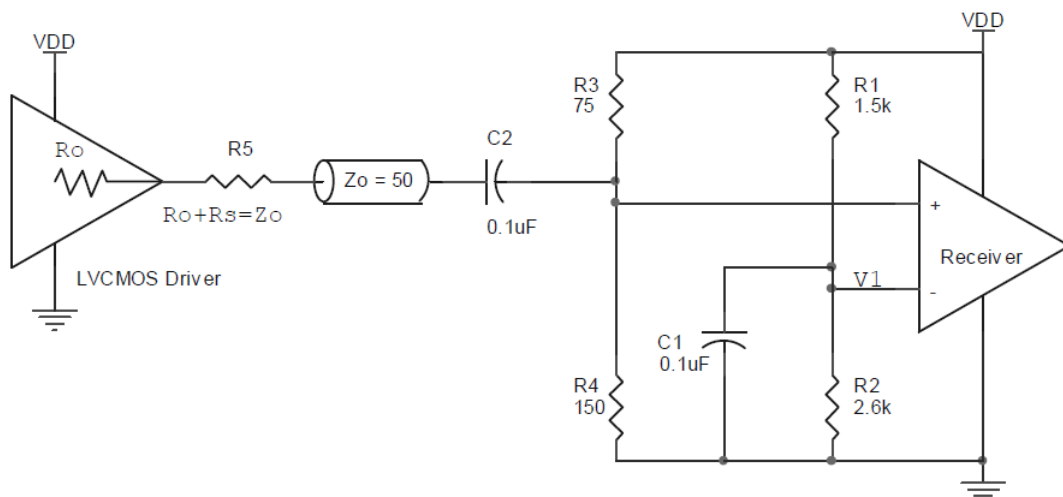

Figure 5. Example Schematic for Wiring a Differential Input to Accept Single-ended Levels

The values in the figure are for when both the single-ended swing and  $V_{DD}$  are at the same voltage. This configuration requires that the sum of the output impedance of the driver ( $R_O$ ) and the series resistance ( $R_S$ ) equals the transmission line impedance. In addition, matched termination at the input will attenuate the signal in half. This can be done in one of two ways. First,  $R_3$  and  $R_4$  in parallel should equal the transmission line

impedance and the signal DC offset after AC coupling should be equal to  $V_1$  (in other words, 1.2V in this example). For most  $Z_O = 50\Omega$  applications,  $R_3 = 75\Omega$  and  $R_4$  can be 130 $\Omega$ . By keeping the same  $R_3/R_4$  ratio, the values of the resistors can be increased to reduce the loading for a slower or weaker LVCMOS driver.

When using single-ended signaling, the noise rejection benefits of differential signaling are reduced. Even though the input can handle larger amplitude signaling, it is recommended that the amplitude be reduced. For single-ended applications, the swing can be larger. Make sure the single-ended logic high and logic low signal operates within the specification limit. Though some of the recommended components might not be used, the pads should be placed in the layout. They can be used for debugging purposes. The datasheet specifications are characterized and confirmed by using a differential signal.

### 5.4 1.8V Differential Clock Input Interface

The CLK /nCLK accepts LVDS, LVPECL, and other differential signals. The differential input signal must meet both the  $V_{PP}$  and  $V_{CMR}$  input requirements. Figure 6 to Figure 8 show interface examples for the CLK /nCLK input driven by the most common driver types. The input interfaces suggested here are examples only. If the driver is from another vendor, use their termination recommendation. Consult with the vendor of the driver component to confirm the driver termination requirements.

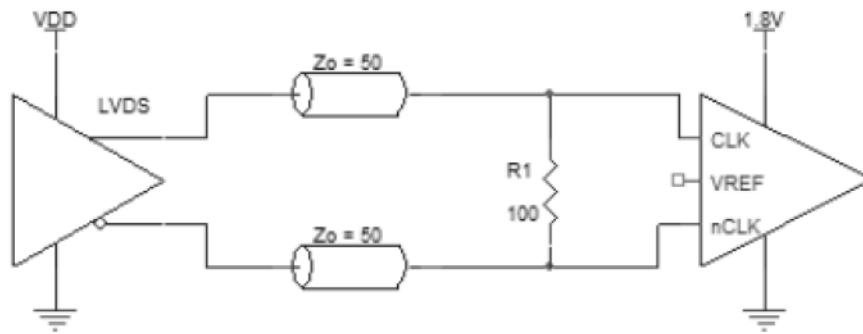

Figure 6. Differential Input Driven by an LVDS Driver – DC Coupling

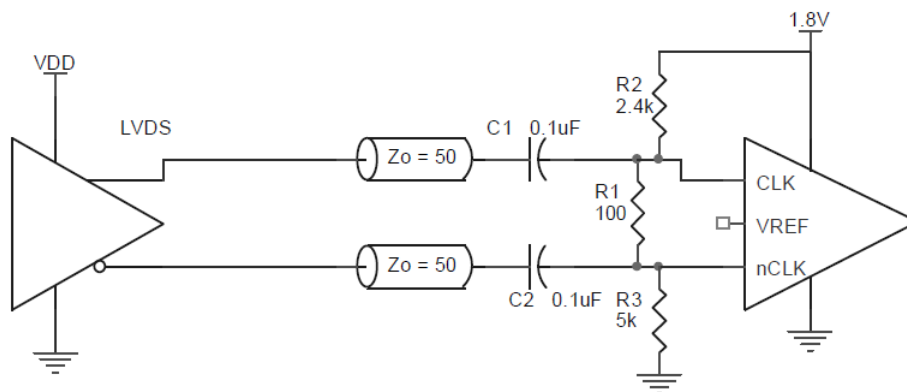

Figure 7. Differential Input Driven by an LVDS Driver – AC Coupling

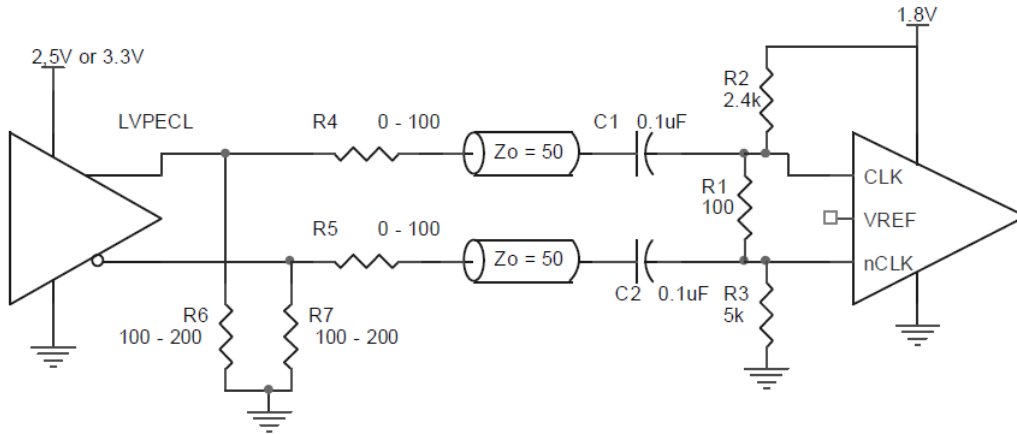

Figure 8. Differential Input Driven by an LVPECL Driver – AC Coupling

### 5.5 LVDS Driver Termination

For a general LVDS interface, the recommended value for the termination impedance ( $Z_T$ ) is between  $90\Omega$  and  $132\Omega$ . The actual value should be selected to match the differential impedance ( $Z_O$ ) of your transmission line. A typical point-to-point LVDS design uses a  $100\Omega$  parallel resistor at the receiver and a  $100\Omega$  differential transmission-line environment. In order to avoid any transmission-line reflection issues, the components should be surface-mounted and must be placed as close to the receiver as possible. Renesas offers a full line of LVDS compliant devices with two types of output structures: current source and voltage source.

The standard termination schematic as shown in Figure 9 can be used with either type of output structure. Figure 10, which can also be used with both output types, is an optional termination with center tap capacitance to help filter common mode noise. The capacitor value should be approximately  $50\text{pF}$ . If using a non-standard termination, it is recommended to contact Renesas and confirm if the output structure is current source or voltage source type. In addition, since these outputs are LVDS compatible, the input receiver's amplitude and common-mode input range should be verified for compatibility with the output.

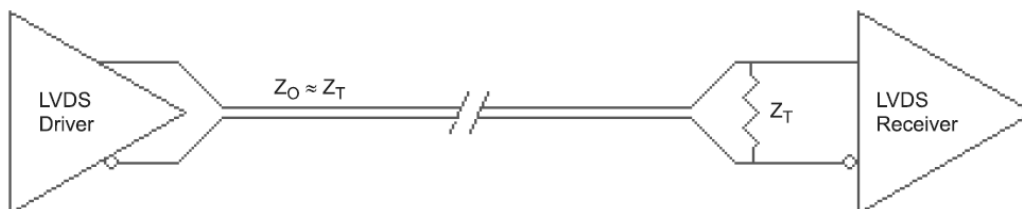

Figure 9. Standard LVDS Termination

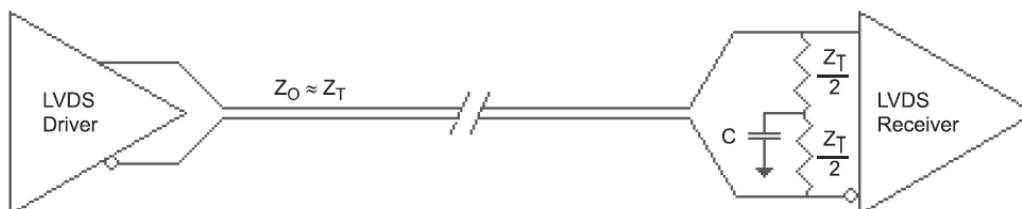
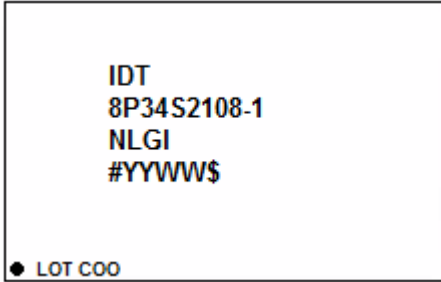

Figure 10. Optional LVDS Termination

## 6. Package Outline Drawings

The package outline drawings are located at the end of this document and are accessible from the Renesas website (see [Ordering Information](#) for POD links). The package information is the most current data available and is subject to change without revision of this document.

## 7. Marking Diagram



- Lines 2 and 3: part number.
- Line 4:
  - “#” denotes the stepping number.
  - “YYWW” denotes the last two digits of the year and workweek that the part was assembled.
  - “\$” denotes the lot sequence.
- “LOT” denotes the lot number.
- “COO” denotes country of origin.

## 8. Ordering Information

Part Number	Package Description	Carrier Type	Temperature Range
8P34S2108-1NLGI	9.0 × 9.0 × 0.9 mm <a href="#">64-VFQFPN</a>	Tray	-40 to +85°C
8P34S2108-1NLGI8		Tape and Reel, Pin 1 Orientation: EIA-481-C (see <a href="#">Table 4</a> )	-40 to +85°C
8P34S2108-1NLGI/W	9.0 × 9.0 × 0.9 mm <a href="#">64-VFQFPN</a>	Tape and Reel, Pin 1 Orientation: EIA-481-D (see <a href="#">Table 4</a> )	-40 to +85°C

Table 4. Pin 1 Orientation in Tape and Reel Packaging

Part Number Suffix	Pin 1 Orientation	Illustration
8	Quadrant 1 (EIA-481-C)	
/W	Quadrant 2 (EIA-481-D)	

## 9. Revision History

Revision	Date	Description
1.00	Jul 31, 2024	Initial release.



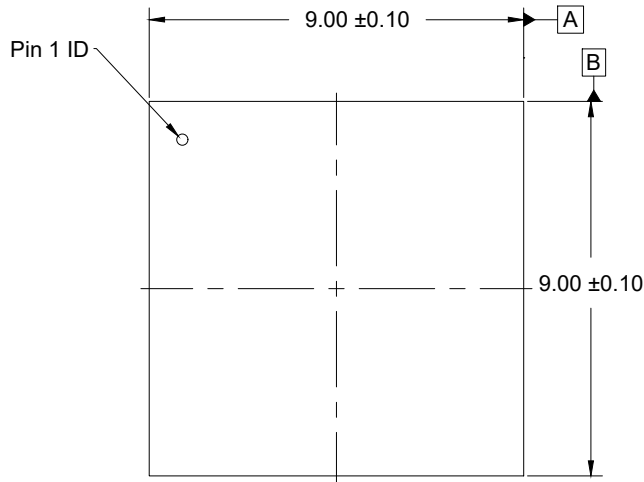

TOP VIEW

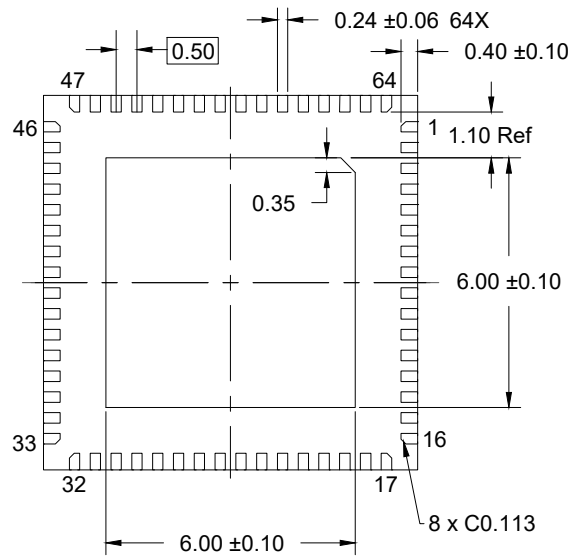

BOTTOM VIEW

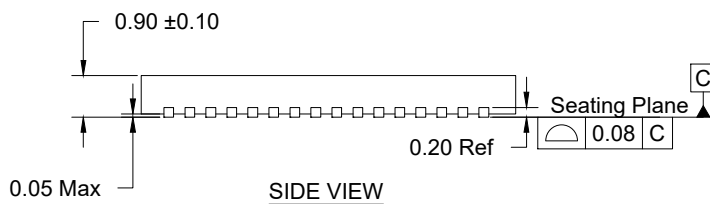

SIDE VIEW

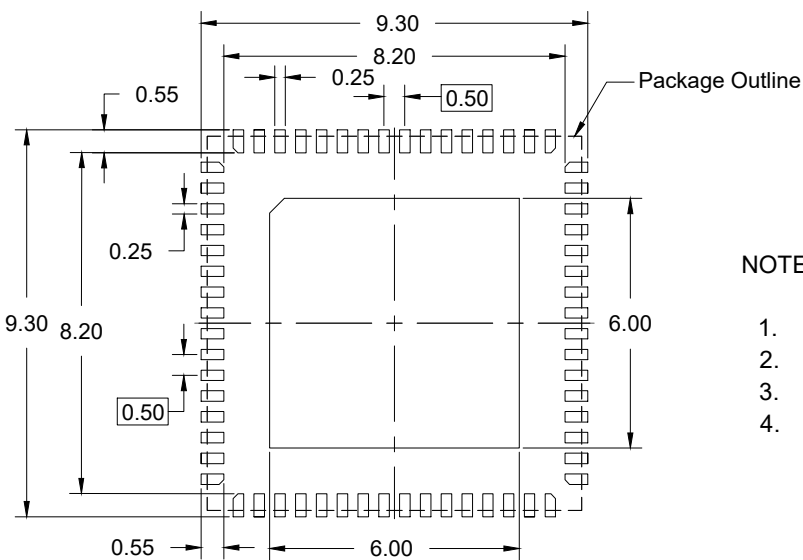

RECOMMENDED LAND PATTERN  
(PCB Top View, NSMD Design)

NOTES:

1. JEDEC compatible.
2. All dimensions are in mm and angles are in degrees.
3. Use  $\pm 0.05$  mm for the non-toleranced dimensions.
4. Numbers in ( ) are for references only.

## IMPORTANT NOTICE AND DISCLAIMER

RENESAS ELECTRONICS CORPORATION AND ITS SUBSIDIARIES (“RENESAS”) PROVIDES TECHNICAL SPECIFICATIONS AND RELIABILITY DATA (INCLUDING DATASHEETS), DESIGN RESOURCES (INCLUDING REFERENCE DESIGNS), APPLICATION OR OTHER DESIGN ADVICE, WEB TOOLS, SAFETY INFORMATION, AND OTHER RESOURCES “AS IS” AND WITH ALL FAULTS, AND DISCLAIMS ALL WARRANTIES, EXPRESS OR IMPLIED, INCLUDING, WITHOUT LIMITATION, ANY IMPLIED WARRANTIES OF MERCHANTABILITY, FITNESS FOR A PARTICULAR PURPOSE, OR NON-INFRINGEMENT OF THIRD-PARTY INTELLECTUAL PROPERTY RIGHTS.

These resources are intended for developers who are designing with Renesas products. You are solely responsible for (1) selecting the appropriate products for your application, (2) designing, validating, and testing your application, and (3) ensuring your application meets applicable standards, and any other safety, security, or other requirements. These resources are subject to change without notice. Renesas grants you permission to use these resources only to develop an application that uses Renesas products. Other reproduction or use of these resources is strictly prohibited. No license is granted to any other Renesas intellectual property or to any third-party intellectual property. Renesas disclaims responsibility for, and you will fully indemnify Renesas and its representatives against, any claims, damages, costs, losses, or liabilities arising from your use of these resources. Renesas' products are provided only subject to Renesas' Terms and Conditions of Sale or other applicable terms agreed to in writing. No use of any Renesas resources expands or otherwise alters any applicable warranties or warranty disclaimers for these products.

(Disclaimer Rev.1.01)

### Corporate Headquarters

TOYOSU FORESIA, 3-2-24 Toyosu,  
Koto-ku, Tokyo 135-0061, Japan  
[www.renesas.com](http://www.renesas.com)

### Trademarks

Renesas and the Renesas logo are trademarks of Renesas Electronics Corporation. All trademarks and registered trademarks are the property of their respective owners.

### Contact Information

For further information on a product, technology, the most up-to-date version of a document, or your nearest sales office, please visit [www.renesas.com/contact-us/](http://www.renesas.com/contact-us/).