

## Description

The 9DBL07x1 devices are 3.3V members of IDT's Full-Featured PCIe clock family. The 9DBL07x1 devices support PCIe Gen1–4 Common Clocked (CC) and PCIe Separate Reference Independent Spread (SRIS) systems. They offer a choice of integrated output terminations providing direct connection to 85Ω or 100Ω transmission lines. The 9DBL07P1 can be factory programmed with a user-defined power up default SMBus configuration.

## Recommended Application

PCIe Gen1–4 clock distribution for Riser Cards, Storage, Networking, JBOD, Communications, Access Points

## Output Features

- 7 – 1-200 MHz Low-Power (LP) HCSL DIF pairs
  - 9DBL0741 default Zout = 100Ω
  - 9DBL0751 default Zout = 85Ω
  - 9DBL07P1 factory programmable defaults
- Easy AC-coupling to other logic families, see IDT application note [AN-891](#).

## Key Specifications

- DIF *additive* cycle-to-cycle jitter < 5ps
- DIF output-to-output skew < 50ps
- *Additive* phase jitter is 0ps (typical rms) for PCIe Gen1–4 CC, SRIS
- *Additive* phase jitter 111fs rms typ. at 156.25M (1.5M to 10M)

## Block Diagram

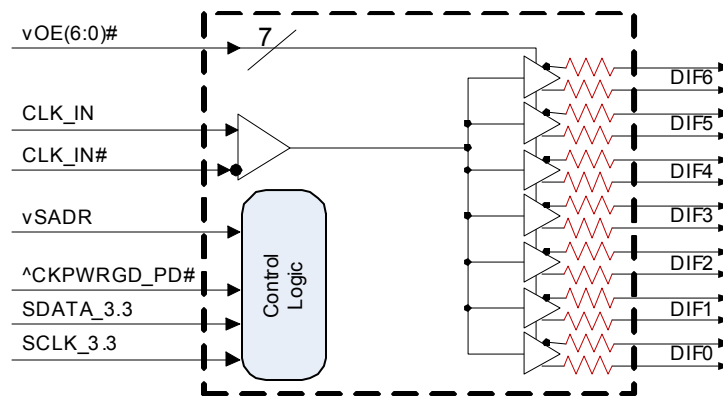

**Note:** Resistors default to internal on 41/51 devices. P1 devices have programmable default impedances on an output-by-output basis.

## Features/Benefits

- Direct connection to 100Ω (xx41) or 85Ω (xx51) transmission lines; saves 28 resistors compared to standard PCIe devices
- 134mW typical power consumption; eliminate thermal concerns
- VDDIO allows 50% power savings at optional 1.05V; maximum power savings
- SMBus-selectable features allows optimization to customer requirements:
  - control input polarity
  - control input pull up/downs
  - slew rate for each output
  - differential output amplitude
  - output impedance for each output
- Customer defined SMBus power up default can be programmed into P1 device; allows exact optimization to customer requirements
- OE# pins; support DIF power management
- HCSL differential input; can be driven by common clock sources
- Spread Spectrum tolerant; allows reduction of EMI
- Device contains default configuration; SMBus interface not required for device operation
- Three selectable SMBus addresses; multiple devices can easily share an SMBus segment
- Space saving 40-pin 5 x 5mm VFQFPN; minimal board space

## Pin Configuration

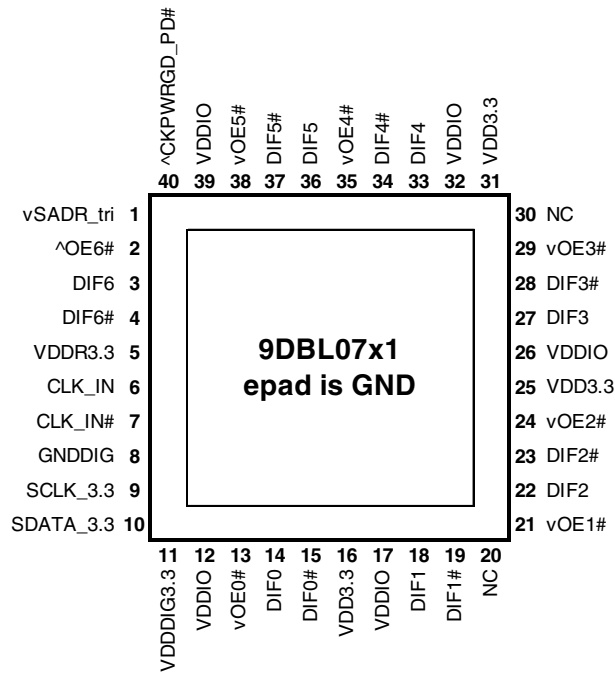

### 40-VFQFPN, 5x5mm 0.4mm pin pitch

^v prefix indicates internal 120KOhm pull up AND pull down resistor (biased to VDD/2)  
 v prefix indicates internal 120KOhm pull down resistor  
 ^ prefix indicates internal 120KOhm pull up resistor

## SMBus Address Selection Table

	SADR	Address	+ Read/Write bit
State of SADR on first application of CKPWRGD_PD#	0	1101011	x
	M	1101100	x
	1	1101101	x

## Power Management Table

CKPWRGD_PD#	CLK_IN	SMBus OEx bit	OEx# Pin	DIFx	
				True O/P	Comp. O/P
0	X	X	X	Low <sup>1</sup>	Low <sup>1</sup>
1	Running	0	X	Low <sup>1</sup>	Low <sup>1</sup>
1	Running	1	0	Running	Running
1	Running	1	1	Low <sup>1</sup>	Low <sup>1</sup>

1. The output state is set by B11[1:0] (Low/Low default)

## Power Connections

Pin Number	VDD	VDDIO	GND	Description
5			41	Input receiver analog
11			8	Digital Power
16,25,31		12,17,26,32,39	41	DIF outputs

## Pin Descriptions

PIN #	PIN NAME	PIN TYPE	DESCRIPTION
1	vSADR_tri	LATCHED IN	Tri-level latch to select SMBus Address. See SMBus Address Selection Table.
2	^OE6#	IN	Active low input for enabling DIF pair 6. This pin has an internal pull-up resistor. 1 =disable outputs, 0 = enable outputs
3	DIF6	OUT	Differential true clock output
4	DIF6#	OUT	Differential Complementary clock output
5	VDDR3.3	PWR	3.3V power for differential input clock (receiver). This VDD should be treated as an Analog power rail and filtered appropriately.
6	CLK_IN	IN	True Input for differential reference clock.
7	CLK_IN#	IN	Complementary Input for differential reference clock.
8	GNDDIG	GND	Ground pin for digital circuitry
9	SCLK_3.3	IN	Clock pin of SMBus circuitry, 3.3V tolerant.
10	SDATA_3.3	I/O	Data pin for SMBus circuitry, 3.3V tolerant.
11	VDDDIG3.3	PWR	3.3V digital power (dirty power)
12	VDDIO	PWR	Power supply for differential outputs
13	vOE0#	IN	Active low input for enabling DIF pair 0. This pin has an internal pull-down. 1 =disable outputs, 0 = enable outputs
14	DIF0	OUT	Differential true clock output
15	DIF0#	OUT	Differential Complementary clock output
16	VDD3.3	PWR	Power supply, nominal 3.3V
17	VDDIO	PWR	Power supply for differential outputs
18	DIF1	OUT	Differential true clock output
19	DIF1#	OUT	Differential Complementary clock output
20	NC	N/A	No Connection.
21	vOE1#	IN	Active low input for enabling DIF pair 1. This pin has an internal pull-down. 1 =disable outputs, 0 = enable outputs
22	DIF2	OUT	Differential true clock output
23	DIF2#	OUT	Differential Complementary clock output
24	vOE2#	IN	Active low input for enabling DIF pair 2. This pin has an internal pull-down. 1 =disable outputs, 0 = enable outputs
25	VDD3.3	PWR	Power supply, nominal 3.3V
26	VDDIO	PWR	Power supply for differential outputs
27	DIF3	OUT	Differential true clock output
28	DIF3#	OUT	Differential Complementary clock output
29	vOE3#	IN	Active low input for enabling DIF pair 3. This pin has an internal pull-down. 1 =disable outputs, 0 = enable outputs
30	NC	N/A	No Connection.
31	VDD3.3	PWR	Power supply, nominal 3.3V
32	VDDIO	PWR	Power supply for differential outputs
33	DIF4	OUT	Differential true clock output
34	DIF4#	OUT	Differential Complementary clock output
35	vOE4#	IN	Active low input for enabling DIF pair 4. This pin has an internal pull-down. 1 =disable outputs, 0 = enable outputs
36	DIF5	OUT	Differential true clock output
37	DIF5#	OUT	Differential Complementary clock output
38	vOE5#	IN	Active low input for enabling DIF pair 5. This pin has an internal pull-down. 1 =disable outputs, 0 = enable outputs
39	VDDIO	PWR	Power supply for differential outputs
40	^CKPWRGD_PD#	IN	Input notifies device to sample latched inputs and start up on first high assertion. Low enters Power Down Mode, subsequent high assertions exit Power Down Mode. This pin has internal pull-up resistor.
41	ePAD	GND	Connect paddle to ground.

## Test Loads

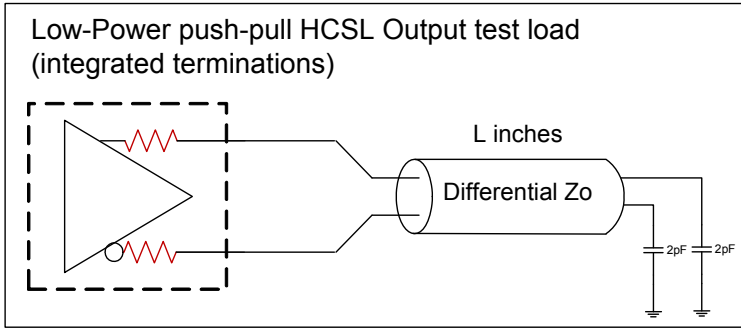

L = 5 inches

## Alternate Terminations

The 9DBL family can easily drive LVPECL, LVDS, and CML logic. See [“AN-891 Driving LVPECL, LVDS, and CML Logic with IDT’s “Universal” Low-Power HCSL Outputs”](#) for details.

### Terminations

Device	$Z_o$ ( $\Omega$ )	$R_s$ ( $\Omega$ )
9DBL0741	100	None needed
9DBL0751	100	7.5
9DBL07P1	100	Prog.
9DBL0741	85	N/A
9DBL0751	85	None needed
9DBL07P1	85	Prog.

## Absolute Maximum Ratings

Stresses above the ratings listed below can cause permanent damage to the 9DBL07x1. These ratings, which are standard values for IDT commercially rated parts, are stress ratings only. Functional operation of the device at these or any other conditions above those indicated in the operational sections of the specifications is not implied. Exposure to absolute maximum rating conditions for extended periods can affect product reliability. Electrical parameters are guaranteed only over the recommended operating temperature range.

PARAMETER	SYMBOL	CONDITIONS	MIN	TYP	MAX	UNITS	NOTES
Supply Voltage	VDDx				4.6	V	1,2
Input Voltage	V <sub>IN</sub>		-0.5		V <sub>DD</sub> +0.5	V	1,3
Input High Voltage, SMBus	V <sub>IHSMB</sub>	SMBus clock and data pins			3.9	V	1
Storage Temperature	T <sub>s</sub>		-65		150	°C	1
Junction Temperature	T <sub>j</sub>				125	°C	1
Input ESD protection	ESD prot	Human Body Model	2500			V	1

<sup>1</sup>Guaranteed by design and characterization, not 100% tested in production.

<sup>2</sup>Operation under these conditions is neither implied nor guaranteed.

<sup>3</sup>Not to exceed 4.6V.

## Electrical Characteristics–SMBus Parameters

TA = T<sub>AMB</sub>; Supply Voltages per normal operation conditions, See Test Loads for Loading Conditions

PARAMETER	SYMBOL	CONDITIONS	MIN	TYP	MAX	UNITS	NOTES
SMBus Input Low Voltage	V <sub>ILSMB</sub>	V <sub>DD</sub> SMB = 3.3V			0.8	V	
SMBus Input High Voltage	V <sub>IHSMB</sub>	V <sub>DD</sub> SMB = 3.3V	2.1		3.6	V	
SMBus Output Low Voltage	V <sub>OLSMB</sub>	@ I <sub>PULLUP</sub>			0.4	V	
SMBus Sink Current	I <sub>PULLUP</sub>	@ V <sub>OL</sub>	4			mA	
Nominal Bus Voltage	V <sub>DD</sub> SMB		2.7		3.6	V	
SCLK/SDATA Rise Time	t <sub>RSMB</sub>	(Max VIL - 0.15) to (Min VIH + 0.15)			1000	ns	1
SCLK/SDATA Fall Time	t <sub>FSMB</sub>	(Min VIH + 0.15) to (Max VIL - 0.15)			300	ns	1
SMBus Operating Frequency	f <sub>SMB</sub>	SMBus operating frequency			500	kHz	2,3

<sup>1</sup>Guaranteed by design and characterization, not 100% tested in production.

<sup>2</sup>The device must be powered up for the SMBus to function.

<sup>3</sup>The differential input clock must be running for the SMBus to be active

## Electrical Characteristics–Clock Input Parameters

TA = T<sub>AMB</sub>; Supply Voltages per normal operation conditions, See Test Loads for Loading Conditions

PARAMETER	SYMBOL	CONDITIONS	MIN	TYP	MAX	UNITS	NOTES
Input Crossover Voltage - DIF_IN	V <sub>CROSS</sub>	Cross Over Voltage	150		900	mV	1
Input Swing - DIF_IN	V <sub>SWING</sub>	Differential value	300			mV	1
Input Slew Rate - DIF_IN	dv/dt	Measured differentially	0.4		8	V/ns	1,2
Input Leakage Current	I <sub>IN</sub>	V <sub>IN</sub> = V <sub>DD</sub> , V <sub>IN</sub> = GND	-5		5	uA	
Input Duty Cycle	d <sub>tin</sub>	Measurement from differential waveform	45		55	%	1
Input Jitter - Cycle to Cycle	J <sub>DIFIn</sub>	Differential Measurement	0		125	ps	1

<sup>1</sup>Guaranteed by design and characterization, not 100% tested in production.

<sup>2</sup>Slew rate measured through +/-75mV window centered around differential zero

## Electrical Characteristics–Input/Supply/Common Parameters–Normal Operating Conditions

TA = T<sub>AMB</sub>, Supply Voltages per normal operation conditions, See Test Loads for Loading Conditions

PARAMETER	SYMBOL	CONDITIONS	MIN	TYP	MAX	UNITS	NOTES
Supply Voltage	VDDx	Supply voltage for core and analog	3.135	3.3	3.465	V	
Output Supply Voltage	VDDIO	Supply voltage for Low Power HCSL Outputs	0.95	1.05-3.3	3.465	V	
Ambient Operating Temperature	T <sub>AMB</sub>	Industrial range	-40	25	85	°C	
Input High Voltage	V <sub>IH</sub>	Single-ended inputs, except SMBus	0.75 V <sub>DDx</sub>		V <sub>DDx</sub> + 0.3	V	
Input Low Voltage	V <sub>IL</sub>		-0.3		0.25 V <sub>DDx</sub>	V	
Input High Voltage	V <sub>IHtri</sub>	Single-ended tri-level inputs ('_tri' suffix)	0.75 V <sub>DDx</sub>		V <sub>DD</sub> + 0.3	V	
Input Mid Voltage	V <sub>IMtri</sub>		0.4 V <sub>DDx</sub>	0.5 V <sub>DDx</sub>	0.6 V <sub>DDx</sub>	V	
Input Low Voltage	V <sub>ILtri</sub>		-0.3		0.25 V <sub>DDx</sub>	V	
Input Current	I <sub>IN</sub>	Single-ended inputs, V <sub>IN</sub> = GND, V <sub>IN</sub> = VDD	-5		5	uA	
	I <sub>INP</sub>	Single-ended inputs V <sub>IN</sub> = 0 V; Inputs with internal pull-up resistors V <sub>IN</sub> = VDD; Inputs with internal pull-down resistors	-50		50	uA	
Input Frequency	F <sub>IN</sub>		1		200	MHz	2
Pin Inductance	L <sub>pin</sub>				7	nH	1
Capacitance	C <sub>IN</sub>	Logic Inputs, except DIF_IN	1.5		5	pF	1
	C <sub>INDIF_IN</sub>	DIF_IN differential clock inputs	1.5		2.7	pF	1
	C <sub>OUT</sub>	Output pin capacitance			6	pF	1
Clk Stabilization	T <sub>STAB</sub>	From V <sub>DD</sub> Power-Up and after input clock stabilization or de-assertion of PD# to 1st clock			1	ms	1,2
Input SS Modulation Frequency PCIe	f <sub>MODINPCIe</sub>	Allowable Frequency for PCIe Applications (Triangular Modulation)	30		33	kHz	
Input SS Modulation Frequency non-PCIe	f <sub>MODIN</sub>	Allowable Frequency for non-PCIe Applications (Triangular Modulation)	0		66	kHz	
OE# Latency	t <sub>LATOE#</sub>	DIF start after OE# assertion DIF stop after OE# deassertion	1		3	clocks	1,3
Tdrive_PD#	t <sub>DRVPD</sub>	DIF output enable after PD# de-assertion			300	us	1,3
Tfall	t <sub>F</sub>	Fall time of single-ended control inputs			5	ns	2
Trise	t <sub>R</sub>	Rise time of single-ended control inputs			5	ns	2

<sup>1</sup>Guaranteed by design and characterization, not 100% tested in production.

<sup>2</sup>Control input must be monotonic from 20% to 80% of input swing.

<sup>3</sup>Time from deassertion until outputs are >200 mV

## Electrical Characteristics–DIF Low-Power HCSL Outputs

TA = T<sub>AMB</sub>, Supply Voltages per normal operation conditions, See Test Loads for Loading Conditions

PARAMETER	SYMBOL	CONDITIONS	MIN	TYP	MAX	UNITS	NOTES
Slew rate	dV/dt	Scope averaging on, fast setting	1.7	2.7	4	V/ns	1,2,3
	dV/dt	Scope averaging on, slow setting	0.8	1.9	2.8	V/ns	1,2,3
Slew rate matching	$\Delta$ dV/dt	Slew rate matching		6	20	%	1,4
Voltage High	V <sub>HIGH</sub>	Statistical measurement on single-ended signal using oscilloscope math function. (Scope averaging on)	660	783	850	mV	7
Voltage Low	V <sub>LOW</sub>		-150	-17	150		7
Max Voltage	V <sub>max</sub>	Measurement on single ended signal using absolute value. (Scope averaging off)		818	1150	mV	7
Min Voltage	V <sub>min</sub>		-300	-54			7
Crossing Voltage (abs)	V <sub>cross_abs</sub>	Scope averaging off	250	377	550	mV	1,5
Crossing Voltage (var)	$\Delta$ -V <sub>cross</sub>	Scope averaging off		18	140	mV	1,6

<sup>1</sup> Guaranteed by design and characterization, not 100% tested in production.

<sup>2</sup> Measured from differential waveform

<sup>3</sup> Slew rate is measured through the V<sub>swing</sub> voltage range centered around differential 0V. This results in a +/-150mV window around differential 0V.

<sup>4</sup> Matching applies to rising edge rate for Clock and falling edge rate for Clock#. It is measured using a +/-75mV window centered on the average cross point where Clock rising meets Clock# falling. The median cross point is used to calculate the voltage thresholds the oscilloscope is to use for the edge rate calculations.

<sup>5</sup> V<sub>cross</sub> is defined as voltage where Clock = Clock# measured on a component test board and only applies to the differential rising edge (i.e. Clock rising and Clock# falling).

<sup>6</sup> The total variation of all V<sub>cross</sub> measurements in any particular system. Note that this is a subset of V<sub>cross\_min/max</sub> (V<sub>cross</sub> absolute) allowed. The intent is to limit V<sub>cross</sub> induced modulation by setting  $\Delta$ -V<sub>cross</sub> to be smaller than V<sub>cross</sub> absolute.

<sup>7</sup> At default SMBus settings.

## Electrical Characteristics–Current Consumption

TA = T<sub>AMB</sub>, Supply Voltages per normal operation conditions, See Test Loads for Loading Conditions

PARAMETER	SYMBOL	CONDITIONS	MIN	TYP	MAX	UNITS	NOTES
Operating Supply Current	I <sub>DD</sub>	VDD + VDDR All outputs active @100MHz, 100 $\Delta$ Loads		12	16	mA	
	I <sub>DDDIG</sub>	VDDDIG All outputs active @100MHz, 100 $\Delta$ Loads		0.4	0.8	mA	
	I <sub>DDIO</sub>	VDDIO All outputs active @100MHz, 100 $\Delta$ Loads		28	32	mA	
Powerdown Current	I <sub>DDPD</sub>	VDD + VDDR, CKPWRGD_PD#=0		1.4	2	mA	2
	I <sub>DDDIGPD</sub>	VDDDIG, CKPWRGD_PD#=0		0.4	0.8	mA	2
	I <sub>DDIOPD</sub>	VDDIO, CKPWRGD_PD#=0		0.0	0.1	mA	2

<sup>1</sup> Guaranteed by design and characterization, not 100% tested in production.

<sup>2</sup> Input clock stopped.

## Electrical Characteristics–Output Duty Cycle, Jitter, and Skew Characteristics

TA = T<sub>AMB</sub>, Supply Voltages per normal operation conditions, See Test Loads for Loading Conditions

PARAMETER	SYMBOL	CONDITIONS	MIN	TYP	MAX	UNITS	NOTES
Duty Cycle Distortion	t <sub>DCD</sub>	Measured differentially, 100MHz	-1	-0.1	1	%	1,3
Skew, Input to Output	t <sub>pd</sub>	V <sub>T</sub> = 50%	2200	2982	4000	ps	1
Skew, Output to Output	t <sub>sk3</sub>	V <sub>T</sub> = 50%		43	50	ps	1,4
Jitter, Cycle to cycle	t <sub>jcc-cyc</sub>	Additive Jitter		0.1	1	ps	1,2

<sup>1</sup> Guaranteed by design and characterization, not 100% tested in production.

<sup>2</sup> Measured from differential waveform

<sup>3</sup> Duty cycle distortion is the difference in duty cycle between the output and the input clock when the device is operated in bypass mode.

<sup>4</sup> All outputs at default slew rate

## Electrical Characteristics–Filtered Phase Jitter Parameters - PCIe Common Clocked (CC) Architectures<sup>1,5</sup>

T<sub>AMB</sub> = over the specified operating range. Supply Voltages per normal operation conditions, See Test Loads for Loading Conditions

PARAMETER	SYMBOL	CONDITIONS	MIN	TYP	MAX	INDUSTRY LIMIT	UNITS	Notes
Additive Phase Jitter	t <sub>jphPCIeG1-CC</sub>	PCIe Gen 1		0.4	2	n/a	ps (p-p)	2,3
	t <sub>jphPCIeG2-CC</sub>	PCIe Gen 2 Lo Band 10kHz < f < 1.5MHz (PLL BW of 5-16MHz or 8-5MHz, CDR = 5MHz)		0.0	0.1		ps (rms)	2,4
		PCIe Gen 2 High Band 1.5MHz < f < Nyquist (50MHz) (PLL BW of 5-16MHz or 8-5MHz, CDR = 5MHz)		0.24	0.5		ps (rms)	2,4
	t <sub>jphPCIeG3-CC</sub>	PCIe Gen 3 (PLL BW of 2-4MHz or 2-5MHz, CDR = 10MHz)		0.07	0.15		ps (rms)	2,4
	t <sub>jphPCIeG4-CC</sub>	PCIe Gen 4 (PLL BW of 2-4MHz or 2-5MHz, CDR = 10MHz)		0.07	0.15		ps (rms)	2,4

<sup>1</sup> Applies to all differential outputs, guaranteed by design and characterization.

<sup>2</sup> Based on PCIe Base Specification Rev4.0 version 0.7draft. See <http://www.pcisig.com> for latest specifications.

<sup>3</sup> Sample size of at least 100K cycles. This figures extrapolates to 108ps pk-pk @ 1M cycles for a BER of 1-12.

<sup>4</sup> For RMS values additive jitter is calculated by solving the following equation for b [ $a^2+b^2=c^2$ ] where a is rms input jitter and c is rms total jitter.

<sup>5</sup> Driven by 9FGL0841 or equivalent



## Electrical Characteristics—Filtered Phase Jitter Parameters - PCIe Separate Reference Independent Spread (SRIS) Architectures<sup>1</sup>

T<sub>AMB</sub> = over the specified operating range. Supply Voltages per normal operation conditions, See Test Loads for Loading Conditions

PARAMETER	SYMBOL	CONDITIONS	MIN	TYP	MAX	INDUSTRY LIMIT	UNITS	Notes
Additive Phase Jitter	t <sub>jphPCIeG1-SRIS</sub>	PCIe Gen 1	TBD			Note 5	ps (pk-pk)	2,3
	t <sub>jphPCIeG2-SRIS</sub>	PCIe Gen 2 (PLL BW of 16MHz, CDR = 5MHz)		0.3	0.4		ps (rms)	2
	t <sub>jphPCIeG3-SRIS</sub>	PCIe Gen 3 (PLL BW of 2-4MHz or 2-5MHz, CDR = 10MHz)		0.03	0.13		ps (rms)	2
	t <sub>jphPCIeG4-SRIS</sub>	PCIe Gen 4 (PLL BW of 2-4MHz or 2-5MHz, CDR = 10MHz)	TBD				ps (rms)	2

<sup>1</sup> Applies to all differential outputs, guaranteed by design and characterization.

<sup>2</sup> Based PCIe Base Specification Rev3.1a filters. These filters are different than Common Clock filters. See <http://www.pcisig.com> for latest specifications and are not defined for Gen1 or Gen4

<sup>3</sup> Sample size of at least 100K cycles. This figures extrapolates to 108ps pk-pk @ 1M cycles for a BER of 1-12.

<sup>4</sup> For RMS values, additive jitter is calculated by solving the following equation for b [ $a^2+b^2=c^2$ ] where a is rms input jitter and c is rms total jitter.

<sup>5</sup> As of PCIe Base Specification Rev4.0 draft 0.7, SRIS limits are defined as implementation dependent.

## Electrical Characteristics—Unfiltered Phase Jitter Parameters<sup>1</sup>

T<sub>A</sub> = T<sub>AMB</sub>, Supply Voltages per normal operation conditions, See Test Loads for Loading Conditions

PARAMETER	SYMBOL	CONDITIONS	MIN	TYP	MAX	INDUSTRY LIMIT	UNITS	Notes
Additive Phase Jitter	t <sub>jph156M</sub>	156.25MHz, 1.5MHz to 10MHz, -20dB/decade rollover < 1.5MHz, -40db/decade rolloff > 10MHz		111		N/A	fs (rms)	2,3
	t <sub>jph156M12k-20</sub>	156.25MHz, 12kHz to 20MHz, -20dB/decade rollover < 12kHz, -40db/decade rolloff > 20MHz		272		N/A	fs (rms)	2,3

<sup>1</sup> Applies to all differential outputs, guaranteed by design and characterization.

<sup>2</sup> Driven by Rohde & Schartz SMA100

<sup>3</sup> For RMS values, additive jitter is calculated by solving the following equation for b [ $a^2+b^2=c^2$ ] where a is rms input jitter and c is rms total jitter.

## General SMBus Serial Interface Information

### How to Write

- Controller (host) sends a start bit
- Controller (host) sends the write address
- IDT clock will **acknowledge**
- Controller (host) sends the beginning byte location = N
- IDT clock will **acknowledge**
- Controller (host) sends the byte count = X
- IDT clock will **acknowledge**
- Controller (host) starts sending Byte N through Byte N+X-1
- IDT clock will **acknowledge** each byte **one at a time**
- Controller (host) sends a Stop bit

Index Block Write Operation			
Controller (Host)			IDT (Slave/Receiver)
T	starT bit		
Slave Address			
WR	WRite		
			ACK
Beginning Byte = N			
			ACK
Data Byte Count = X			
			ACK
Beginning Byte N		X Byte	
			ACK
O			O
O			O
O			O
Byte N + X - 1			
			ACK
P	stoP bit		

### How to Read

- Controller (host) will send a start bit
- Controller (host) sends the write address
- IDT clock will **acknowledge**
- Controller (host) sends the beginning byte location = N
- IDT clock will **acknowledge**
- Controller (host) will send a separate start bit
- Controller (host) sends the read address
- IDT clock will **acknowledge**
- IDT clock will send the data byte count = X
- IDT clock sends Byte N+X-1
- IDT clock sends **Byte 0 through Byte X (if X<sub>(H)</sub> was written to Byte 8)**
- Controller (host) will need to acknowledge each byte
- Controller (host) will send a not acknowledge bit
- Controller (host) will send a stop bit

Index Block Read Operation			
Controller (Host)			IDT (Slave/Receiver)
T	starT bit		
Slave Address			
WR	WRite		
			ACK
Beginning Byte = N			
			ACK
RT	Repeat starT		
Slave Address			
RD	ReaD		
			ACK
			Data Byte Count=X
ACK		X Byte	Beginning Byte N
ACK			
O			O
O			O
O			O
			Byte N + X - 1
N	Not acknowledge		
P	stoP bit		

**Note: SMBus Address is Latched on SADR pin.**  
**Unless otherwise indicated, default values are for the x41 and xx51. P1 devices are fully factory programmable.**

**SMBus Table: Output Enable Register <sup>1</sup>**

Byte 0	Name	Control Function	Type	0	1	Default
Bit 7	DIF OE5	Output Enable	RW	Low/Low	Enabled	1
Bit 6	DIF OE4	Output Enable	RW	Low/Low	Enabled	1
Bit 5	Reserved					1
Bit 4	DIF OE3	Output Enable	RW	Low/Low	Enabled	1
Bit 3	DIF OE2	Output Enable	RW	Low/Low	Enabled	1
Bit 2	DIF OE1	Output Enable	RW	Low/Low	Enabled	1
Bit 1	Reserved					1
Bit 0	DIF OE0	Output Enable	RW	Low/Low	Enabled	1

1. A low on these bits will override the OE# pin and force the differential output to the state indicated by B11[1:0] (Low/Low default)

**SMBus Table: Output Enable and Output Amplitude Control Register**

Byte 1	Name	Control Function	Type	0	1	Default
Bit 7	Reserved					0
Bit 6	Reserved					1
Bit 5	DIF OE6	Output Enable	RW	Low/Low	Enabled	1
Bit 4	Reserved					0
Bit 3	Reserved					1
Bit 2	Reserved					1
Bit 1	AMPLITUDE 1	Controls Output Amplitude	RW	00 = 0.6V	01 = 0.68V	1
Bit 0	AMPLITUDE 0		RW	10 = 0.75V	11 = 0.85V	0

1. A low on these bits will override the OE# pin and force the differential output to the state indicated by B11[1:0] (Low/Low default)

**SMBus Table: DIF Slew Rate Control Register**

Byte 2	Name	Control Function	Type	0	1	Default
Bit 7	SLEWRATESEL DIF5	Adjust Slew Rate	RW	Slow Setting	Fast Setting	1
Bit 6	SLEWRATESEL DIF4	Adjust Slew Rate	RW	Slow Setting	Fast Setting	1
Bit 5	Reserved					1
Bit 4	SLEWRATESEL DIF3	Adjust Slew Rate	RW	Slow Setting	Fast Setting	1
Bit 3	SLEWRATESEL DIF2	Adjust Slew Rate	RW	Slow Setting	Fast Setting	1
Bit 2	SLEWRATESEL DIF1	Adjust Slew Rate	RW	Slow Setting	Fast Setting	1
Bit 1	Reserved					1
Bit 0	SLEWRATESEL DIF0	Adjust Slew Rate	RW	Slow Setting	Fast Setting	1

**SMBus Table: DIF Slew Rate Control Register**

Byte 3	Name	Control Function	Type	0	1	Default
Bit 7	Reserved					1
Bit 6	Reserved					1
Bit 5	Reserved					0
Bit 4	Reserved					0
Bit 3	Reserved					0
Bit 2	Reserved					1
Bit 1	Reserved					1
Bit 0	SLEWRATESEL DIF6	Adjust Slew Rate	RW	Slow Setting	Fast Setting	1

Byte 4 is Reserved and reads back 'hFF'

**SMBus Table: Revision and Vendor ID Register**

Byte 5	Name	Control Function	Type	0	1	Default
Bit 7	RID3	Revision ID	R	B rev = 0001		0
Bit 6	RID2		R			0
Bit 5	RID1		R			0
Bit 4	RID0		R			1
Bit 3	VID3	VENDOR ID	R	0001 = IDT		0
Bit 2	VID2		R			0
Bit 1	VID1		R			0
Bit 0	VID0		R			1

**SMBus Table: Device Type/Device ID**

Byte 6	Name	Control Function	Type	0	1	Default
Bit 7	Device Type1	Device Type	R	00 = FGx, 01 = DBx, 10 = DMx, 11= DBx w/oPLL		1
Bit 6	Device Type0		R			1
Bit 5	Device ID5	Device ID	R	000111 binary or 07 hex		0
Bit 4	Device ID4		R			0
Bit 3	Device ID3		R			0
Bit 2	Device ID2		R			1
Bit 1	Device ID1		R			1
Bit 0	Device ID0		R			1

**SMBus Table: Byte Count Register**

Byte 7	Name	Control Function	Type	0	1	Default
Bit 7		Reserved				0
Bit 6		Reserved				0
Bit 5		Reserved				0
Bit 4	BC4	Byte Count Programming	RW	Writing to this register will configure how many bytes will be read back, default is = 8 bytes.		0
Bit 3	BC3		RW			1
Bit 2	BC2		RW			0
Bit 1	BC1		RW			0
Bit 0	BC0		RW			0

Bytes 8 and 9 are Reserved

**SMBus Table: PLL MN Enable, PD\_Restore**

Byte 10	Name	Control Function	Type	0	1	Default
Bit 7		Reserved				1
Bit 6	Power-Down (PD) Restore	Restore Default Config. In PD	RW	Clear Config in PD	Keep Config in PD	1
Bit 5		Reserved				0
Bit 4		Reserved				0
Bit 3		Reserved				0
Bit 2		Reserved				0
Bit 1		Reserved				0
Bit 0		Reserved				0

**SMBus Table: Impedance Control**

Byte 11	Name	Control Function	Type	0	1	Default
Bit 7	DIF6_imp[1]	Set Zout	RW	00=33Ω DIF Zout	10=100Ω DIF Zout	see Note
Bit 6	DIF6_imp[0]		RW	01=85Ω DIF Zout	11 = Reserved	
Bit 5	Reserved					0
Bit 4	Reserved					0
Bit 3	Reserved					0
Bit 2	Reserved					0
Bit 1	STP[1]	True/Complement DIF Output Disable State	RW	00 = Low/Low	10 = High/Low	0
Bit 0	STP[0]		RW	01 = HiZ/HiZ	11 = Low/High	0

Note: xx41 = 10, xx51 = 01, P1 = factory programmable.

**SMBus Table: Impedance Control**

Byte 12	Name	Control Function	Type	0	1	Default
Bit 7	DIF2_imp[1]	Set Zout	RW	00=33Ω DIF Zout	10=100Ω DIF Zout	see Note
Bit 6	DIF2_imp[0]		RW	01=85Ω DIF Zout	11 = Reserved	
Bit 5	DIF1_imp[1]	Set Zout	RW	00=33Ω DIF Zout	10=100Ω DIF Zout	
Bit 4	DIF1_imp[0]		RW	01=85Ω DIF Zout	11 = Reserved	
Bit 3	Reserved					
Bit 2	Reserved					
Bit 1	DIF0_imp[1]	Set Zout	RW	00=33Ω DIF Zout	10=100Ω DIF Zout	
Bit 0	DIF0_imp[0]		RW	01=85Ω DIF Zout	11 = Reserved	

Note: xx41 = 10, xx51 = 01, P1 = factory programmable.

**SMBus Table: Impedance Control**

Byte 13	Name	Control Function	Type	0	1	Default
Bit 7	DIF5_imp[1]	Set Zout	RW	00=33Ω DIF Zout	10=100Ω DIF Zout	see Note
Bit 6	DIF5_imp[0]		RW	01=85Ω DIF Zout	11 = Reserved	
Bit 5	DIF4_imp[1]	Set Zout	RW	00=33Ω DIF Zout	10=100Ω DIF Zout	
Bit 4	DIF4_imp[0]		RW	01=85Ω DIF Zout	11 = Reserved	
Bit 3	Reserved					
Bit 2	Reserved					
Bit 1	DIF3_imp[1]	Set Zout	RW	00=33Ω DIF Zout	10=100Ω DIF Zout	
Bit 0	DIF3_imp[0]		RW	01=85Ω DIF Zout	11 = Reserved	

Note: xx41 = 10, xx51 = 01, P1 = factory programmable.

**SMBus Table: Pull-up Pull-down Control**

Byte 14	Name	Control Function	Type	0	1	Default
Bit 7	OE2_pu/pd[1]	Set Pull-up(PuP)/	RW	00=None	10=Pup	0
Bit 6	OE2_pu/pd[0]	Pull-down(Pdwn)	RW	01=Pdwn	11 = Pup+Pdwn	1
Bit 5	OE1_pu/pd[1]	Set Pull-up(PuP)/	RW	00=None	10=Pup	0
Bit 4	OE1_pu/pd[0]	Pull-down(Pdwn)	RW	01=Pdwn	11 = Pup+Pdwn	1
Bit 3	Reserved					0
Bit 2	Reserved					1
Bit 1	OE0_pu/pd[1]	Set Pull-up(PuP)/	RW	00=None	10=Pup	0
Bit 0	OE0_pu/pd[0]	Pull-down(Pdwn)	RW	01=Pdwn	11 = Pup+Pdwn	1

Note: These values are for xx41 and xx51. P1 is factory programmable.

**SMBus Table: Pull-up Pull-down Control**

Byte 15	Name	Control Function	Type	0	1	Default
Bit 7	OE5_pu/pd[1]	Set Pull-up(PuP)/ Pull-down(Pdwn)	RW	00=None	10=Pup	0
Bit 6	OE5_pu/pd[0]		RW	01=Pdwn	11 = Pup+Pdwn	1
Bit 5	OE4_pu/pd[1]	Set Pull-up(PuP)/ Pull-down(Pdwn)	RW	00=None	10=Pup	0
Bit 4	OE4_pu/pd[0]		RW	01=Pdwn	11 = Pup+Pdwn	1
Bit 3	Reserved					0
Bit 2	Reserved					1
Bit 1	OE3_pu/pd[1]	Set Pull-up(PuP)/ Pull-down(Pdwn)	RW	00=None	10=Pup	0
Bit 0	OE3_pu/pd[0]		RW	01=Pdwn	11 = Pup+Pdwn	1

Note: These values are for xx41 and xx51. P1 is factory programmable.

**SMBus Table: Pull-up Pull-down Control**

Byte 16	Name	Control Function	Type	0	1	Default
Bit 7	Reserved					0
Bit 6	Reserved					0
Bit 5	Reserved					1
Bit 4	Reserved					0
Bit 3	OE6_pu/pd[1]	Set Pull-up(PuP)/ Pull-down(Pdwn)	RW	00=None	10=Pup	0
Bit 2	OE6_pu/pd[0]		RW	01=Pdwn	11 = Pup+Pdwn	1
Bit 1	CKPWRGD_PD_pu/pd[1]	CKPWRGD_PD Pull-up(PuP)/ Pull-down(Pdwn) control	RW	00=None	10=Pup	1
Bit 0	CKPWRGD_PD_pu/pd[0]		RW	01=Pdwn	11 = Pup+Pdwn	0

Note: These values are for xx41 and xx51. P1 is factory programmable.

Bytes 17 is Reserved and reads back 0h00.

**SMBus Table: Polarity Control**

Byte 18	Name	Control Function	Type	0	1	Default
Bit 7	OE5_polarity	Sets OE polarity	RW	Enabled when Low	Enabled when High	0
Bit 6	OE4_polarity	Sets OE polarity	RW	Enabled when Low	Enabled when High	0
Bit 5	Reserved					0
Bit 4	OE3_polarity	Sets OE polarity	RW	Enabled when Low	Enabled when High	0
Bit 3	OE2_polarity	Sets OE polarity	RW	Enabled when Low	Enabled when High	0
Bit 2	OE1_polarity	Sets OE polarity	RW	Enabled when Low	Enabled when High	0
Bit 1	Reserved					0
Bit 0	OE0_polarity	Sets OE polarity	RW	Enabled when Low	Enabled when High	0

**SMBus Table: Polarity Control**

Byte 19	Name	Control Function	Type	0	1	Default
Bit 7	Reserved					0
Bit 6	Reserved					0
Bit 5	Reserved					0
Bit 4	Reserved					0
Bit 3	Reserved					0
Bit 2	Reserved					0
Bit 1	OE6_polarity	Sets OE polarity	RW	Enabled when Low	Enabled when High	0
Bit 0	CKPWRGD_PD	Sets CKPWRGD_PD polarity	RW	Power Down when Low	Power Down when High	0

## Marking Diagrams

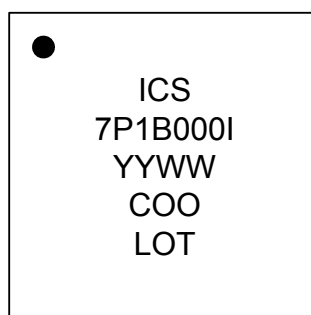
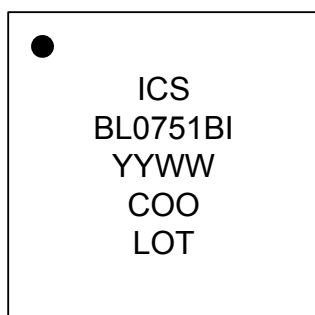
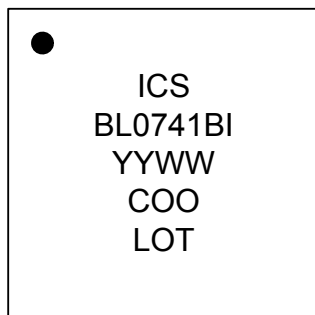

### Notes:

1. "LOT" is the lot sequence number.
2. "COO" denotes country of origin.
3. YYWW is the last two digits of the year and week that the part was assembled.
4. Line 2: truncated part number
5. "I" denotes industrial temperature range device.

## Thermal Characteristics

PARAMETER	SYMBOL	CONDITIONS	PKG	TYP VALUE	UNITS	NOTES
Thermal Resistance	$\theta_{JC}$	Junction to Case	NDG40	42	°C/W	1
	$\theta_{Jb}$	Junction to Base		2.4	°C/W	1
	$\theta_{JA0\theta}$	Junction to Air, still air		39	°C/W	1
	$\theta_{JA1}$	Junction to Air, 1 m/s air flow		33	°C/W	1
	$\theta_{JA3}$	Junction to Air, 3 m/s air flow		28	°C/W	1
	$\theta_{JA5}$	Junction to Air, 5 m/s air flow		27	°C/W	1

<sup>1</sup>ePad soldered to board

REVISIONS			
REV	DESCRIPTION	DATE	APPROVED
00	INITIAL RELEASE	5/17/16	JH

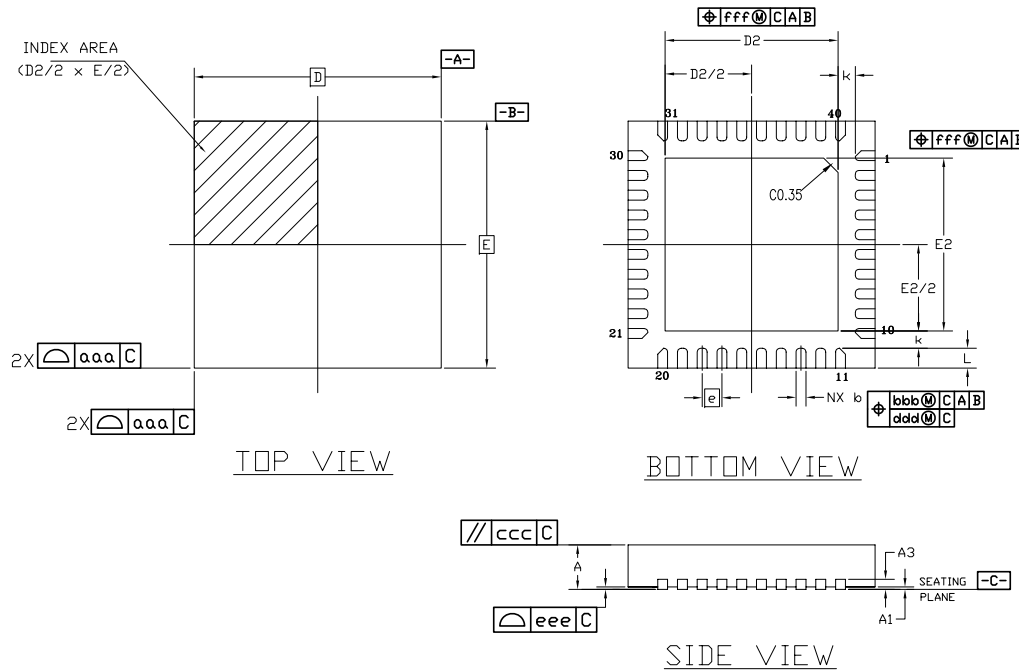

SYMBOL	DIMENSION		
	MIN	NOM	MAX
b	0.15	0.20	0.25
D	5.00 BSC		
E	5.00 BSC		
D2	3.40	3.50	3.60
E2	3.40	3.50	3.60
L	0.30	0.40	0.50
e	0.40 BSC		
N	40		
ND	10 (note 3)		
NE	10 (note 3)		
A	0.80	0.90	1.00
A1	0.00	0.02	0.05
A3	0.2 REF		
k	0.35 REF		
aaa	0.10		
bbb	0.07		
ccc	0.10		
ddd	0.05		
eee	0.08		
fff	0.10		

NOTES:

1. ALL DIMENSIONING AND TOLERANCING CONFORM TO ANSI Y14.5M-1982
2. ALL DIMENSIONS ARE IN MILLIMETERS.
3. ND AND NE REFER TO THE NUMBER OF TERMINALS ON EACH D AND E SIDE RESPECTIVELY.

TOLERANCES UNLESS SPECIFIED		 6024 SILVER CREEK VALLEY ROAD, SAN JOSE, CA 95138 PHONE: (408) 284-8200 FAX: (408) 284-3572 <a href="http://www.IDT.com">www.IDT.com</a>
DECIMAL	ANGULAR	
X±.1	±1°	
XX±.05		
XXX±.030		
APPROVALS	DATE	TITLE
DRAWN <i>mæ</i>	05/31/10	NDG40 PACKAGE OUTLINE
CHECKED		5.0 x 5.0 mm BODY, EPAD 3.50mm SQ. 0.40 mm PITCH QFN
		SIZE
		C
		DRAWING No.
		PSC-4292-02
		REV
		00
DO NOT SCALE DRAWING		SHEET 1 OF 2



REVISIONS			
REV	DESCRIPTION	DATE	APPROVED
00	INITIAL RELEASE	5/17/16	JH

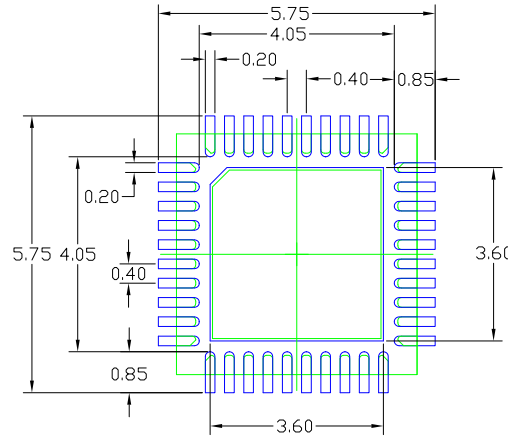

RECOMMENDED LAND PATTERN

NOTES:

1. ALL DIMENSIONS ARE IN mm. ANGLES IN DEGREES.
2. TOP DOWN VIEW AS VIEWED ON PCB.
3. COMPONENT OUTLINE SHOWS FOR REFERENCE IN GREEN.
4. LAND PATTERN IN BLUE. NSMD PATTERN ASSUMED.
5. LAND PATTERN RECOMMENDATION PER IPC-7351B GENERIC REQUIREMENT FOR SURFACE MOUNT DESIGN AND LAND PATTERN.

TOLERANCES UNLESS SPECIFIED DECIMAL ANGULAR X±.1 ±1° XX±.05 XXX± .030		 www.IDT.com 6024 SILVER CREEK VALLEY ROAD, SAN JOSE, CA 95138 PHONE: (408) 284-8200 FAX: (408) 284-3572
APPROVALS	DATE	
DRAWN <i>mr</i>	05/31/10	TITLE NDG40 PACKAGE OUTLINE 5.0 x 5.0 mm BODY, EPAD 3.50mm SQ. 0.40 mm PITCH QFN
CHECKED		
SIZE	DRAWING No.	
C	PSC-4292-02	00
DO NOT SCALE DRAWING		SHEET 2 OF 2

## Ordering Information

Part / Order Number	Output Impedance	Shipping Packaging	Package	Temperature
9DBL0741BKILF	100Ω	Trays	40-pin VFQFPN	-40 to +85° C
9DBL0741BKILFT		Tape and Reel	40-pin VFQFPN	-40 to +85° C
9DBL0751BKILF	85Ω	Trays	40-pin VFQFPN	-40 to +85° C
9DBL0751BKILFT		Tape and Reel	40-pin VFQFPN	-40 to +85° C
9DBL07P1BxxxKILF	Factory configurable. Contact IDT for additional information.	Trays	40-pin VFQFPN	-40 to +85° C
9DBL07P1BxxxKILFT		Tape and Reel	40-pin VFQFPN	-40 to +85° C

“LF” suffix to the part number are the Pb-Free configuration and are RoHS compliant.

“B” is the device revision designator (will not correlate with the datasheet revision).

“xxx” is a unique factory assigned number to identify a particular default configuration.

## Revision History

Rev.	Initiator	Issue Date	Description	Page #
A	RDW	9/19/2016	<ol style="list-style-type: none"> <li>1. Updated front page text</li> <li>2. Changed VDDA3.3 pin to VDD3.3, since this part has no PLL</li> <li>3. Removed references to PLL mode, since this part has no PLL</li> <li>4. Regrouped IDD values to simplify the table</li> <li>5. Updated Electrical tables to latest version, including PCIe Gen4</li> <li>6. Updated ordering information to B rev</li> <li>7. Corrected readback of SMBus B1[1:0], B3[7], B5[4], B10[7], B16[5] - most of these are reserved bits</li> <li>8. Updated footnote text under block diagram.</li> <li>9. Updated block diagram for stylistic consistency.</li> <li>10. Updated electrical tables with char data, move to final.</li> </ol>	Various
B	RDW	9/28/2016	Fixed corrupted ohm symbols in Bytes 11, 12, and 13 register tables	13
C	RDW	8/1/2017	Removed reference to differential waveform in slew rate matching spec	7



## IMPORTANT NOTICE AND DISCLAIMER

RENESAS ELECTRONICS CORPORATION AND ITS SUBSIDIARIES (“RENESAS”) PROVIDES TECHNICAL SPECIFICATIONS AND RELIABILITY DATA (INCLUDING DATASHEETS), DESIGN RESOURCES (INCLUDING REFERENCE DESIGNS), APPLICATION OR OTHER DESIGN ADVICE, WEB TOOLS, SAFETY INFORMATION, AND OTHER RESOURCES “AS IS” AND WITH ALL FAULTS, AND DISCLAIMS ALL WARRANTIES, EXPRESS OR IMPLIED, INCLUDING, WITHOUT LIMITATION, ANY IMPLIED WARRANTIES OF MERCHANTABILITY, FITNESS FOR A PARTICULAR PURPOSE, OR NON-INFRINGEMENT OF THIRD-PARTY INTELLECTUAL PROPERTY RIGHTS.

These resources are intended for developers who are designing with Renesas products. You are solely responsible for (1) selecting the appropriate products for your application, (2) designing, validating, and testing your application, and (3) ensuring your application meets applicable standards, and any other safety, security, or other requirements. These resources are subject to change without notice. Renesas grants you permission to use these resources only to develop an application that uses Renesas products. Other reproduction or use of these resources is strictly prohibited. No license is granted to any other Renesas intellectual property or to any third-party intellectual property. Renesas disclaims responsibility for, and you will fully indemnify Renesas and its representatives against, any claims, damages, costs, losses, or liabilities arising from your use of these resources. Renesas' products are provided only subject to Renesas' Terms and Conditions of Sale or other applicable terms agreed to in writing. No use of any Renesas resources expands or otherwise alters any applicable warranties or warranty disclaimers for these products.

(Disclaimer Rev.1.01 Jan 2024)

### Corporate Headquarters

TOYOSU FORESIA, 3-2-24 Toyosu,  
Koto-ku, Tokyo 135-0061, Japan  
[www.renesas.com](http://www.renesas.com)

### Trademarks

Renesas and the Renesas logo are trademarks of Renesas Electronics Corporation. All trademarks and registered trademarks are the property of their respective owners.

### Contact Information

For further information on a product, technology, the most up-to-date version of a document, or your nearest sales office, please visit [www.renesas.com/contact-us/](http://www.renesas.com/contact-us/).