

## General Description

The DA14530 is an ultra-low power SoC integrating a 2.4 GHz transceiver and an Arm® Cortex-M0+ microcontroller with a RAM of 48 kB and a One-Time Programmable (OTP) memory of 32 kB. It can be used as a standalone application processor or as a data pump in hosted systems.

The radio transceiver, the baseband processor, and the qualified Bluetooth® low energy stack is fully compliant with the Bluetooth® Low Energy 5.1 standard.

The DA14530 has dedicated hardware for the Link Layer implementation of BLE and interface controllers for enhanced connectivity capabilities.

The BLE firmware includes the L2CAP service layer protocols, Security Manager (SM), Attribute Protocol (ATT), the Generic Attribute Profile (GATT), and the Generic Access Profile (GAP). All profiles published by the Bluetooth® SIG as well as custom profiles are supported.

The device is suitable for disposables, wireless sensor nodes, beacons, proximity tags and trackers, smart HID devices (stylus, keyboards, mice, and trackpads), toys, and medical and industrial applications.

## Key Features

- Compatible with Bluetooth v5.1, ETSI EN 300 328 and EN 300 440 Class 2 (Europe), FCC CFR47 Part 15 (US) and ARIB STD-T66 (Japan)
- Supports up to three BLE connections
- Typical cold boot to radio active 35 ms
- Processing power
  - 16 MHz 32-bit Arm® Cortex-M0+ with SWD interface
  - 18300 EEMBC IoTMark-BLE® score
  - Dedicated Link Layer and AES-128 Encryption Processor
  - Software-based True Random Number Generator (TRNG)
- Memories
  - 32 kB One-Time-Programmable (OTP)
  - 48 kB Retainable System RAM
  - 144 kB ROM
- Power management
  - Integrated core LDO with sleep mode
  - Clock-less hibernation mode 300 nA
  - Built-in temperature sensor for die temperature monitoring
- Clocks
  - 32 MHz crystal and 32 MHz RC osc.
  - 32 kHz crystal and 32/512 kHz RC osc.
  - 15 kHz RCX as crystal replacement
- Programmable Reset Circuitry
- 2x General purpose Timers with capture and PWM capabilities
- Digital interfaces
  - 12 GPIOs
  - 2x UARTs (one with flow control)
  - SPI Master/Slave up to 32 MHz (Master)
  - I2C bus at 100 kHz and 400 kHz
  - 3-axis capable Quadrature Decoder
  - Keyboard controller
- Analog interfaces
  - 4-channel 10-bit ADC
- Radio transceiver
  - Fully integrated 2.4 GHz CMOS transceiver
  - Single wire antenna
  - TX: 9 mA, RX: 5 mA (system currents with VBAT = 3 V and 0 dBm)
  - Programmable transmit output power from -19.5 dBm to +2.5 dBm
  - -94 dBm receiver sensitivity
- Packages:
  - FCGQFN 24 pins, 2.2 × 3, 0.4 mm pitch

## Applications

- Medical applications
- Disposables
- Beacons
- Proximity tags and trackers
- Wireless sensor nodes
  - Fitness trackers
  - Consumer health
- Smartwatches
- Human interface devices (HID)
  - Stylus pens
  - Keyboards
  - Mouse devices
  - Trackpads
- Toys
- Industrial appliances

## Key Benefits

- Lowest power consumption
- Smallest system size
- Lowest system cost

## System Diagram



Figure 1: System Diagram

## Contents

General Description .....	1
Key Features .....	1
Applications .....	2
Key Benefits .....	2
System Diagram .....	2
Contents .....	3
Figures .....	8
Tables .....	10
<b>1 Block Diagram .....</b>	<b>18</b>
<b>2 Package and Pinout .....</b>	<b>20</b>
<b>3 Specifications .....</b>	<b>24</b>
3.1 Absolute Maximum Ratings .....	25
3.2 Recommended Operating Conditions .....	25
3.3 DC Characteristics .....	25
3.4 Timing Characteristics .....	26
3.5 RCX Oscillator .....	26
3.6 XTAL32MHz Oscillator .....	27
3.7 XTAL32kHz Oscillator .....	28
3.8 RC32MHz Oscillator .....	28
3.9 Digital I/O Characteristics .....	28
3.10 Power On Reset .....	30
3.11 GP ADC .....	30
3.12 Temperature Sensor .....	31
3.13 Radio .....	32
<b>4 System Overview .....</b>	<b>36</b>
4.1 Internal Blocks .....	36
4.2 Power Management Unit .....	37
4.2.1 Introduction .....	37
4.2.2 Architecture .....	37
4.2.2.1 Digital Power Domains .....	38
4.2.2.2 Power Modes .....	39
4.2.2.3 VDD Level in Hibernation .....	41
4.2.2.4 Retainable Registers .....	41
4.2.3 Programming .....	41
4.3 HW FSM (Power-up, Wake-up, and Go-to-Sleep) .....	42
4.3.1 Go-to-Sleep and Refresh Bandgap .....	43
4.4 OTP Memory Layout .....	43
4.4.1 OTP Header .....	44
4.4.2 Configuration Script .....	46
4.5 BootROM Sequence .....	47
<b>5 Reset .....</b>	<b>50</b>
5.1 Introduction .....	50
5.2 Architecture .....	50

5.2.1	POR, HW, and SW Reset.....	50
5.2.2	POR Functionality.....	51
5.2.2.1	POR Timer Clock.....	52
5.2.2.2	RST Pad .....	52
5.2.2.3	POR from GPIO.....	52
5.2.3	POR Timing Diagram.....	52
5.2.4	POR Considerations .....	53
5.3	Programming.....	53
<b>6</b>	<b>Arm Cortex-M0+.....</b>	<b>54</b>
6.1	Introduction .....	54
6.2	Architecture .....	55
6.2.1	Interrupts.....	55
6.2.2	System Timer (systick) .....	57
6.2.3	Wake-Up Interrupt Controller.....	57
6.3	Programming.....	57
<b>7</b>	<b>AMBA Bus .....</b>	<b>58</b>
7.1	Introduction .....	58
7.2	Architecture .....	58
7.3	Programming.....	59
<b>8</b>	<b>Memory Map.....</b>	<b>60</b>
<b>9</b>	<b>Memory Controller .....</b>	<b>62</b>
9.1	Introduction .....	62
9.2	Architecture .....	62
9.2.1	Arbitration .....	62
<b>10</b>	<b>Clock Generation.....</b>	<b>64</b>
10.1	Clock Tree.....	64
10.1.1	General Clock Constraints.....	66
10.2	Crystal Oscillators .....	66
10.2.1	Frequency Control (32 MHz Crystal).....	66
10.2.2	Automated Trimming and Settling Notification .....	67
10.3	RC Oscillators .....	68
10.3.1	Frequency Calibration.....	69
<b>11</b>	<b>OTP Controller .....</b>	<b>70</b>
11.1	Introduction .....	70
11.2	Architecture .....	70
11.2.1	OTP Accessing Considerations.....	72
11.3	Programming.....	72
<b>12</b>	<b>DMA Controller .....</b>	<b>73</b>
12.1	Introduction .....	73
12.2	Architecture .....	73
12.2.1	DMA Peripherals.....	73
12.2.2	Input/Output Multiplexer .....	74
12.2.3	DMA Channel Operation.....	74
12.2.4	DMA Arbitration .....	75
12.2.5	Freezing DMA Channels .....	76

12.3	Programming.....	76
12.3.1	Memory to Memory Transfers .....	76
12.3.2	Peripheral to Memory Transfers .....	76
<b>13</b>	<b>I2C Interface.....</b>	<b>78</b>
13.1	Introduction .....	78
13.2	Architecture .....	78
13.2.1	I2C Bus Terms.....	79
13.2.1.1	Bus Transfer Terms .....	80
13.2.2	I2C Behavior .....	80
13.2.2.1	START and STOP Generation .....	81
13.2.2.2	Combined Formats .....	81
13.2.3	I2C Protocols .....	81
13.2.3.1	START and STOP Conditions .....	81
13.2.3.2	Addressing Slave Protocol .....	82
13.2.3.3	Transmitting and Receiving Protocols .....	83
13.2.4	Multiple Master Arbitration.....	84
13.2.5	Clock Synchronization .....	85
13.3	Programming.....	86
<b>14</b>	<b>UART.....</b>	<b>87</b>
14.1	Introduction .....	87
14.2	Architecture .....	88
14.2.1	UART (RS232) Serial Protocol.....	88
14.2.2	Clock Support .....	89
14.2.3	Interrupts.....	89
14.2.4	Programmable THRE Interrupt.....	90
14.2.5	Shadow Registers.....	92
14.2.6	Direct Test Mode .....	92
14.3	Programming.....	92
<b>15</b>	<b>SPI Interface.....</b>	<b>94</b>
15.1	Introduction .....	94
15.2	Architecture .....	95
15.2.1	SPI Timing .....	95
15.3	Programming.....	96
15.3.1	Master Mode.....	96
15.3.2	Slave Mode.....	97
<b>16</b>	<b>Quadrature Decoder.....</b>	<b>98</b>
16.1	Introduction .....	98
16.2	Architecture .....	98
16.3	Programming.....	100
<b>17</b>	<b>Clockless Wakeup Controller.....</b>	<b>101</b>
17.1	Introduction .....	101
17.2	Architecture .....	101
17.3	Programming.....	102
<b>18</b>	<b>Clocked Wakeup Controller .....</b>	<b>103</b>
18.1	Introduction .....	103

18.2	Architecture .....	103
18.3	Programming.....	104
<b>19</b>	<b>Timer 0.....</b>	<b>106</b>
19.1	Introduction .....	106
19.2	Architecture .....	106
19.3	Programming.....	108
19.3.1	Timer Functionality .....	108
19.3.2	PWM Generation .....	109
<b>20</b>	<b>Timer 1.....</b>	<b>109</b>
20.1	Introduction .....	109
20.2	Architecture .....	110
20.3	Programming.....	110
20.3.1	Timer Functionality .....	110
20.3.2	Capture Functionality.....	111
20.3.3	Frequency Measuring Functionality.....	111
<b>21</b>	<b>Timer 2.....</b>	<b>112</b>
21.1	Introduction .....	112
21.2	Architecture .....	113
21.3	Programming.....	114
21.3.1	PWM Generation .....	114
21.3.2	Freeze Functionality .....	114
<b>22</b>	<b>Watchdog Timer .....</b>	<b>115</b>
22.1	Introduction .....	115
22.2	Architecture .....	115
22.3	Programming.....	116
<b>23</b>	<b>Temperature Sensor .....</b>	<b>117</b>
23.1	Introduction .....	117
23.2	Architecture .....	117
23.2.1	Programming .....	118
23.2.1.1	Absolute Temperature .....	118
23.2.1.2	Relative Temperature .....	119
<b>24</b>	<b>Keyboard Controller.....</b>	<b>120</b>
24.1	Introduction .....	120
24.2	Architecture .....	120
24.2.1	Keyboard Scanner .....	120
24.2.2	GPIO Interrupt Generator .....	121
24.3	Programming.....	122
24.3.1	Keyboard Scanner .....	122
24.3.2	GPIO Interrupts.....	122
<b>25</b>	<b>Input/Output Ports.....</b>	<b>123</b>
25.1	Introduction .....	123
25.2	Architecture .....	123
25.2.1	Programmable Pin Assignment .....	123
25.2.1.1	Priority.....	124
25.2.1.2	Direction Control .....	124

25.2.2	General Purpose Port Registers.....	124
25.2.2.1	Port Data Register .....	124
25.2.2.2	Port Set Data Output Register .....	124
25.2.2.3	Port Reset Data Output Register.....	124
25.2.3	Fixed Assignment Functionality.....	124
25.2.4	Types of GPIO Pads.....	125
25.2.5	Driving Strength .....	126
<b>26</b>	<b>General Purpose ADC.....</b>	<b>127</b>
26.1	Introduction .....	127
26.2	Architecture .....	127
26.2.1	Input Channels.....	128
26.2.2	Operating Modes .....	129
26.2.2.1	Enabling the ADC .....	130
26.2.2.2	Manual Mode .....	130
26.2.2.3	Continuous Mode.....	130
26.2.3	Conversion Modes.....	130
26.2.3.1	AD Conversion.....	130
26.2.3.2	Averaging.....	132
26.2.3.3	Chopper Mode .....	132
26.2.4	Additional Settings .....	132
26.2.5	Non-Ideal Effects .....	133
26.2.6	Offset Calibration .....	133
26.2.7	Zero-Scale Adjustment .....	133
26.2.8	Common Mode Adjustment .....	134
26.2.9	Input Impedance, Inductance, and Input Settling .....	134
26.3	Programming.....	134
<b>27</b>	<b>Real Time Clock (RTC).....</b>	<b>135</b>
27.1	Introduction .....	135
27.2	Architecture .....	135
27.3	Programming.....	136
<b>28</b>	<b>Power.....</b>	<b>137</b>
28.1	LDOs .....	137
28.2	POR Circuit .....	137
<b>29</b>	<b>BLE Core .....</b>	<b>138</b>
29.1	Architecture .....	138
29.1.1	Exchange Memory.....	138
29.2	Programming.....	139
29.2.1	Wake-Up IRQ .....	139
29.2.2	Switch from BLE Active Mode to BLE Deep Sleep Mode .....	139
29.2.3	Switch from BLE Deep Sleep Mode to BLE Active Mode .....	140
29.2.3.1	Switching at an Anchor Point.....	140
29.2.3.2	Switching Due to an External Event .....	142
<b>30</b>	<b>Radio.....</b>	<b>143</b>
30.1	Introduction .....	143
30.2	Architecture .....	143
30.2.1	Receiver.....	143

30.2.2	Synthesizer .....	144
30.2.3	Transmitter.....	144
30.2.4	RFIO .....	144
30.2.5	Biasing .....	144
30.2.6	RF Monitoring .....	144
<b>31</b>	<b>Registers .....</b>	<b>145</b>
31.1	Analog Miscellaneous Registers.....	145
31.2	BLE Core Registers .....	147
31.3	Clock Generation and Reset Registers.....	172
31.4	DMA Controller Registers .....	185
31.5	General Purpose ADC Registers .....	199
31.6	General Purpose I/O Registers.....	204
31.7	General Purpose Registers.....	210
31.8	I2C Interface Registers .....	213
31.9	Keyboard Registers.....	232
31.10	Miscellaneous Registers .....	236
31.11	OTP Controller Registers.....	239
31.12	Quadrature Decoder Registers .....	245
31.13	Real Time Clock Registers .....	248
31.14	SPI Interface Registers .....	254
31.15	Timer and Triple PWM Registers.....	259
31.16	Timer1 Registers.....	264
31.17	UART Interface Registers .....	267
31.18	Chip Version Registers .....	322
31.19	Wake-Up Registers .....	323
31.20	Watchdog Registers.....	326
<b>32</b>	<b>Ordering Information .....</b>	<b>328</b>
<b>33</b>	<b>Package Information .....</b>	<b>329</b>
33.1	Moisture Sensitivity Level (MSL).....	329
33.2	Soldering Information.....	329
33.3	Package Outlines .....	329
	<b>Revision History .....</b>	<b>331</b>

## Figures

Figure 1:	System Diagram.....	2
Figure 2:	DA14530 Block Diagram.....	19
Figure 3:	FCGQFN24 Pin Assignment (Top View) .....	20
Figure 4:	Power Management Unit: Bypass Configuration .....	38
Figure 5:	Digital Power Domains.....	38
Figure 6:	Power-Up/Wake-Up/Sleep FSM Diagram.....	42
Figure 7:	Power up/Wake-Up from hibernation.....	42
Figure 8:	Wake-Up from extended/deep sleep.....	43
Figure 9:	Go-to-Sleep and Bandgap Refresh.....	43
Figure 10:	OTP Layout Scheme.....	44
Figure 11:	BootROM Sequence .....	48
Figure 12:	Reset Block Diagram .....	50
Figure 13:	POR Timing Diagram .....	52
Figure 14:	Arm Cortex-M0+ Block Diagram .....	54



Figure 15: AMBA Bus Architecture and Power Domains .....	58
Figure 16: Memory Controller Block Diagram .....	62
Figure 17: Clock Tree Diagram .....	64
Figure 18: Crystal Oscillator Circuits .....	66
Figure 19: XTAL32MHz Oscillator Frequency Trimming.....	67
Figure 20: Automated Mechanism for XTAL32M Trim and Settling.....	68
Figure 21: OTP Controller Block Diagram.....	70
Figure 22: DMA Controller Block Diagram .....	73
Figure 23: DMA Channel Diagram .....	75
Figure 24: I2C Controller Block Diagram.....	78
Figure 25: Master/Slave and Transmitter/Receiver Relationships .....	79
Figure 26: Data Transfer on the I2C Bus .....	80
Figure 27: START and STOP Conditions.....	81
Figure 28: 7-bit Address Format.....	82
Figure 29: 10-bit Address Format.....	82
Figure 30: Master-Transmitter Protocol.....	83
Figure 31: Master-Receiver Protocol.....	84
Figure 32: START BYTE Transfer.....	84
Figure 33: Multiple Master Arbitration .....	85
Figure 34: Multiple Master Clock Synchronization .....	86
Figure 35: UART Block Diagram .....	87
Figure 36: Serial Data Format .....	88
Figure 37: Receiver Serial Data Sampling Points .....	88
Figure 38: Flowchart of Interrupt Generation for Programmable THRE Interrupt Mode.....	91
Figure 39: Flowchart of Interrupt Generation When Not in Programmable THRE Interrupt Mode .....	92
Figure 40: SPI Block Diagram .....	94
Figure 41: SPI Slave Mode Timing (CPOL = 0, CPHA = 0).....	95
Figure 42: Quadrature Decoder Block Diagram .....	98
Figure 43: Moving Forward on Axis X .....	99
Figure 44: Moving Backwards on Axis X.....	99
Figure 45: Digital Filtering and Edge Detection Circuit .....	99
Figure 46: Clockless Wakeup Controller Circuit.....	101
Figure 47: Clocked Wakeup Controller Block Diagram.....	103
Figure 48: Event Counter State Machine for the Wakeup Interrupt Generator.....	104
Figure 49: Timer 0 Block Diagram.....	106
Figure 50: Timer 0 PWM Mode .....	108
Figure 51: Timer 1 Block Diagram.....	110
Figure 52: Timer 2 Block Diagram.....	112
Figure 53: Timer 2 Timing Diagram.....	113
Figure 54: Watchdog Timer Block Diagram .....	115
Figure 55: Temperature Sensor Behavior .....	117
Figure 56: Keyboard Controller Block Diagram.....	120
Figure 57: Keyboard Scanner State Machine .....	121
Figure 58: GPIO Interrupt Generator State Machine .....	122
Figure 59: Port P0 with Programmable Pin Assignment and driving strength .....	123
Figure 60: Type A GPIO Pad - GPIO with Schmitt Trigger on Input .....	125
Figure 61: Type B GPIO Pad - GPIO with Schmitt Trigger and RC Filter on Input.....	126
Figure 62: Block Diagram of GPADC .....	127
Figure 63: GPADC Operation Flow Diagram .....	129
Figure 64: Real Time Clock Block Diagram .....	135
Figure 65: BLE Core Block Diagram .....	138
Figure 66: Entering BLE Deep Sleep mode .....	140
Figure 67: Exit BLE Deep Sleep Mode at Predetermined Time (Zoom In) .....	141
Figure 68: Exit BLE Deep Sleep Mode after Predetermined Time (Zoom In).....	141
Figure 69: Exit BLE Deep Sleep Mode at Predetermined Time (Zoom Out) .....	141
Figure 70: Exit BLE Deep Sleep Mode Due to External Event .....	142
Figure 71: Bluetooth Radio Block Diagram .....	143
Figure 72: FCGQFN24 Package Outline Drawing .....	330

## Tables

Table 1: DA14530 FCGQFN24 Pin Description .....	20
Table 2: Absolute Maximum Ratings.....	25
Table 3: Recommended Operating Conditions .....	25
Table 4: DC Characteristics.....	25
Table 5: Timing Characteristics.....	26
Table 6: RCX Oscillator - Timing Characteristics .....	26
Table 7: XTAL32MHz Oscillator - Recommended Operating Conditions .....	27
Table 8: XTAL oscillator 32kHz - Recommended Operating Conditions .....	28
Table 9: XTAL oscillator 32kHz - Timing Characteristics .....	28
Table 10: RC32MHz Oscillaor - Timing Characteristics.....	28
Table 11: Digital Pad - Recommended Operating Conditions .....	28
Table 12: Digital Pad - DC Characteristics.....	29
Table 13: Digital Pad with LPF - DC Characteristics.....	29
Table 14: Digital Pad with LPF - Recommended Operating Conditions .....	29
Table 15: POR VBAT_LOW - DC Characteristics.....	30
Table 16: POR VBAT_HIGH - DC Characteristics .....	30
Table 17: GP ADC - Recommended Operating Conditions .....	30
Table 18: GP ADC - DC Characteristics .....	30
Table 19: GP ADC - Electrical performance.....	31
Table 20: Temperature Sensor - DC Characteristics .....	31
Table 21: BLE 1Mb/s specifications - Recommended Operating Conditions .....	32
Table 22: BLE 1Mb/s specifications - AC Characteristics .....	32
Table 23: BLE 1Mb/s specifications - Timing Characteristics .....	35
Table 24: BLE 1Mb/s specifications - DC Characteristics .....	35
Table 25: Power Domains Description .....	39
Table 26: Power Modes, Digital Power Domains, Clocks, and Wake-up triggers .....	40
Table 27: VDD_Clamp recommended settings over temperature and load .....	41
Table 28: Retainable Registers .....	41
Table 29: OTP Header .....	44
Table 30: CS Commands and Description .....	46
Table 31: CS Example.....	47
Table 32: Booting Sequence Steps.....	49
Table 33: Reset Signals and Registers .....	51
Table 34: Interrupt List.....	55
Table 35: Arm Documents List .....	57
Table 36: Memory Map.....	60
Table 37: Generated Clocks Description.....	65
Table 38: DMA Served Peripherals.....	74
Table 39: I2C Definition of Bits in First Byte in 10-bit Address Format .....	82
Table 40: UART Baud Rate Generation.....	89
Table 41: UART Interrupt Priorities .....	90
Table 42: SPI Modes Configuration and SCK States.....	95
Table 43: SPI Timing Parameters .....	96
Table 44: Fixed Assignment of Specific Signals .....	124
Table 45: ADC Input Channels.....	128
Table 46: GPADC External Input Channels and Voltage Range .....	128
Table 47: ADC_LDO Start-Up Delay .....	130
Table 48: ADC Sampling Time Constant ( $T_{ADC\_SMPL}$ ).....	131
Table 49: ENOB in Oversampling Mode .....	132
Table 50: GPADC Calibration Procedure for Single-Ended and Differential Modes.....	133
Table 51: Common Mode Adjustment.....	134
Table 52: Register map anamisc2632_bif_00.....	145
Table 53: CLK_REF_SEL_REG (0x50001600) .....	145
Table 54: CLK_REF_CNT_REG (0x50001602).....	146

Table 55: CLK_REF_VAL_L_REG (0x50001604) .....	146
Table 56: CLK_REF_VAL_H_REG (0x50001606).....	146
Table 57: Register map BLE .....	147
Table 58: BLE_RWBLECNTRL_REG (0x40000000) .....	149
Table 59: BLE_VERSION_REG (0x40000004) .....	150
Table 60: BLE_RWBLECONF_REG (0x40000008) .....	151
Table 61: BLE_INTCNTRL_REG (0x4000000C).....	151
Table 62: BLE_INTSTAT_REG (0x40000010).....	152
Table 63: BLE_INTRAWSTAT_REG (0x40000014) .....	153
Table 64: BLE_INTACK_REG (0x40000018) .....	154
Table 65: BLE_BASETIMECNT_REG (0x4000001C) .....	155
Table 66: BLE_FINETIMECNT_REG (0x40000020) .....	155
Table 67: BLE_BDADDR_L_REG (0x40000024) .....	155
Table 68: BLE_BDADDR_H_REG (0x40000028).....	155
Table 69: BLE_CURRENTRXDESCPTR_REG (0x4000002C).....	155
Table 70: BLE_DEEPSLVCNTRL_REG (0x40000030).....	156
Table 71: BLE_DEEPSLWKUP_REG (0x40000034) .....	156
Table 72: BLE_DEEPSLSTAT_REG (0x40000038).....	157
Table 73: BLE_ENBPRESET_REG (0x4000003C).....	157
Table 74: BLE_FINECNTCORR_REG (0x40000040) .....	157
Table 75: BLE_BASETIMECNTCORR_REG (0x40000044) .....	157
Table 76: BLE_DIAGCNTRL_REG (0x40000050) .....	158
Table 77: BLE_DIAGSTAT_REG (0x40000054) .....	158
Table 78: BLE_DEBUGADDMAX_REG (0x40000058) .....	158
Table 79: BLE_DEBUGADDMIN_REG (0x4000005C).....	159
Table 80: BLE_ERRORYPESTAT_REG (0x40000060).....	159
Table 81: BLE_SWPROFILING_REG (0x40000064) .....	161
Table 82: BLE_RADIOCNTRL1_REG (0x40000074).....	161
Table 83: BLE_RADIOPWRUPDN_REG (0x40000080) .....	161
Table 84: BLE_ADVCHMAP_REG (0x40000090) .....	162
Table 85: BLE_ADVTIME_REG (0x400000A0).....	162
Table 86: BLE_ACTSCANSTAT_REG (0x400000A4).....	162
Table 87: BLE_WLPUBADDPTR_REG (0x400000B0) .....	162
Table 88: BLE_WLPRIVADDPTR_REG (0x400000B4) .....	162
Table 89: BLE_WLNBDEV_REG (0x400000B8) .....	163
Table 90: BLE_AESCNTL_REG (0x400000C0) .....	163
Table 91: BLE_AESKEY31_0_REG (0x400000C4) .....	163
Table 92: BLE_AESKEY63_32_REG (0x400000C8) .....	163
Table 93: BLE_AESKEY95_64_REG (0x400000CC).....	163
Table 94: BLE_AESKEY127_96_REG (0x400000D0) .....	163
Table 95: BLE_AESPTR_REG (0x400000D4).....	163
Table 96: BLE_TXMICVAL_REG (0x400000D8).....	164
Table 97: BLE_RXMICVAL_REG (0x400000DC).....	164
Table 98: BLE_RFTESTCNTRL_REG (0x400000E0).....	164
Table 99: BLE_RFTESTTXSTAT_REG (0x400000E4) .....	165
Table 100: BLE_RFTESTRXSTAT_REG (0x400000E8).....	165
Table 101: BLE_TIMGENCNTRL_REG (0x400000F0).....	165
Table 102: BLE_GROSSTIMTGT_REG (0x400000F4).....	165
Table 103: BLE_FINETIMTGT_REG (0x400000F8).....	165
Table 104: BLE_SAMPLECLK_REG (0x400000FC).....	166
Table 105: BLE_COEXIFCNTRL0_REG (0x40000100).....	166
Table 106: BLE_COEXIFCNTRL1_REG (0x40000104).....	167
Table 107: BLE_BLEMPRIO0_REG (0x40000108).....	167
Table 108: BLE_BLEMPRIO1_REG (0x4000010C) .....	168
Table 109: BLE_CNTRL2_REG (0x40000200) .....	168
Table 110: BLE_EM_BASE_REG (0x40000208) .....	170
Table 111: BLE_DIAGCNTRL2_REG (0x4000020C).....	170
Table 112: BLE_DIAGCNTRL3_REG (0x40000210) .....	171
Table 113: Register map CRG .....	172

Table 114: CLK_AMBA_REG (0x50000000) .....	172
Table 115: CLK_FREQ_TRIM_REG (0x50000002) .....	173
Table 116: CLK_PER_REG (0x50000004) .....	173
Table 117: CLK_RADIO_REG (0x50000008) .....	174
Table 118: CLK_CTRL_REG (0x5000000A) .....	174
Table 119: PMU_CTRL_REG (0x50000010) .....	175
Table 120: SYS_CTRL_REG (0x50000012) .....	175
Table 121: SYS_STAT_REG (0x50000014) .....	176
Table 122: TRIM_CTRL_REG (0x50000016) .....	176
Table 123: RAM_PWR_CTRL_REG (0x50000018) .....	177
Table 124: CLK_RC32K_REG (0x50000020) .....	177
Table 125: CLK_XTAL32K_REG (0x50000022) .....	178
Table 126: CLK_RC32M_REG (0x50000024) .....	178
Table 127: CLK_RCX_REG (0x50000026) .....	178
Table 128: BANDGAP_REG (0x50000028) .....	179
Table 129: ANA_STATUS_REG (0x5000002A) .....	179
Table 130: XTAL32M_START_REG (0x50000030) .....	180
Table 131: XTALRDY_CTRL_REG (0x50000034) .....	180
Table 132: XTAL32M_CTRL0_REG (0x50000038) .....	180
Table 133: POR_PIN_REG (0x50000040) .....	181
Table 134: POR_TIMER_REG (0x50000042) .....	181
Table 135: PMU_SLEEP_REG (0x50000050) .....	181
Table 136: POWER_CTRL_REG (0x50000052) .....	181
Table 137: POWER_LEVEL_REG (0x50000054) .....	182
Table 138: XTAL32M_TRSTAT_REG (0x50000032) .....	183
Table 139: Register map crg2632_preg_tim_00 .....	183
Table 140: CLK_RTCDIV_REG (0x5000424C) .....	183
Table 141: Register map DMA .....	185
Table 142: DMA0_A_STARTL_REG (0x50003600) .....	186
Table 143: DMA0_A_STARTH_REG (0x50003602) .....	186
Table 144: DMA0_B_STARTL_REG (0x50003604) .....	186
Table 145: DMA0_B_STARTH_REG (0x50003606) .....	186
Table 146: DMA0_INT_REG (0x50003608) .....	186
Table 147: DMA0_LEN_REG (0x5000360A) .....	187
Table 148: DMA0_CTRL_REG (0x5000360C) .....	187
Table 149: DMA0_IDX_REG (0x5000360E) .....	188
Table 150: DMA1_A_STARTL_REG (0x50003610) .....	189
Table 151: DMA1_A_STARTH_REG (0x50003612) .....	189
Table 152: DMA1_B_STARTL_REG (0x50003614) .....	189
Table 153: DMA1_B_STARTH_REG (0x50003616) .....	189
Table 154: DMA1_INT_REG (0x50003618) .....	189
Table 155: DMA1_LEN_REG (0x5000361A) .....	189
Table 156: DMA1_CTRL_REG (0x5000361C) .....	189
Table 157: DMA1_IDX_REG (0x5000361E) .....	191
Table 158: DMA2_A_STARTL_REG (0x50003620) .....	191
Table 159: DMA2_A_STARTH_REG (0x50003622) .....	191
Table 160: DMA2_B_STARTL_REG (0x50003624) .....	191
Table 161: DMA2_B_STARTH_REG (0x50003626) .....	191
Table 162: DMA2_INT_REG (0x50003628) .....	192
Table 163: DMA2_LEN_REG (0x5000362A) .....	192
Table 164: DMA2_CTRL_REG (0x5000362C) .....	192
Table 165: DMA2_IDX_REG (0x5000362E) .....	193
Table 166: DMA3_A_STARTL_REG (0x50003630) .....	194
Table 167: DMA3_A_STARTH_REG (0x50003632) .....	194
Table 168: DMA3_B_STARTL_REG (0x50003634) .....	194
Table 169: DMA3_B_STARTH_REG (0x50003636) .....	194
Table 170: DMA3_INT_REG (0x50003638) .....	194
Table 171: DMA3_LEN_REG (0x5000363A) .....	194
Table 172: DMA3_CTRL_REG (0x5000363C) .....	194

Table 173: DMA3_IDX_REG (0x5000363E).....	196
Table 174: DMA_REQ_MUX_REG (0x50003680) .....	196
Table 175: DMA_INT_STATUS_REG (0x50003682) .....	197
Table 176: DMA_CLEAR_INT_REG (0x50003684) .....	197
Table 177: Register map GPADC .....	199
Table 178: GP_ADC_CTRL_REG (0x50001500) .....	199
Table 179: GP_ADC_CTRL2_REG (0x50001502) .....	200
Table 180: GP_ADC_CTRL3_REG (0x50001504) .....	201
Table 181: GP_ADC_OFFP_REG (0x50001508) .....	201
Table 182: GP_ADC_OFFN_REG (0x5000150A) .....	201
Table 183: GP_ADC_TRIM_REG (0x5000150C) .....	202
Table 184: GP_ADC_CLEAR_INT_REG (0x5000150E) .....	202
Table 185: GP_ADC_RESULT_REG (0x50001510) .....	202
Table 186: GP_ADC_SEL_REG (0x50001506).....	202
Table 187: Register map GPIO .....	204
Table 188: P0_DATA_REG (0x50003000) .....	204
Table 189: P0_SET_DATA_REG (0x50003002) .....	204
Table 190: P0_RESET_DATA_REG (0x50003004) .....	204
Table 191: P00_MODE_REG (0x50003006) .....	205
Table 192: P01_MODE_REG (0x50003008) .....	206
Table 193: P02_MODE_REG (0x5000300A).....	206
Table 194: P03_MODE_REG (0x5000300C).....	206
Table 195: P04_MODE_REG (0x5000300E).....	207
Table 196: P05_MODE_REG (0x50003010) .....	207
Table 197: P06_MODE_REG (0x50003012) .....	207
Table 198: P07_MODE_REG (0x50003014) .....	207
Table 199: P08_MODE_REG (0x50003016) .....	208
Table 200: P09_MODE_REG (0x50003018) .....	208
Table 201: P010_MODE_REG (0x5000301A).....	208
Table 202: P011_MODE_REG (0x5000301C).....	208
Table 203: PAD_WEAK_CTRL_REG (0x5000301E) .....	209
Table 204: Register map GPREG .....	210
Table 205: SET_FREEZE_REG (0x50003300) .....	210
Table 206: RESET_FREEZE_REG (0x50003302) .....	210
Table 207: DEBUG_REG (0x50003304).....	211
Table 208: GP_STATUS_REG (0x50003306) .....	211
Table 209: GP_CONTROL_REG (0x50003308) .....	211
Table 210: BLE_TIMER_REG (0x5000330A).....	211
Table 211: Register map I2C.....	213
Table 212: I2C_CON_REG (0x50001300).....	214
Table 213: I2C_TAR_REG (0x50001304).....	215
Table 214: I2C_SAR_REG (0x50001308) .....	216
Table 215: I2C_DATA_CMD_REG (0x50001310).....	216
Table 216: I2C_SS_SCL_HCNT_REG (0x50001314).....	217
Table 217: I2C_SS_SCL_LCNT_REG (0x50001318) .....	217
Table 218: I2C_FS_SCL_HCNT_REG (0x5000131C) .....	218
Table 219: I2C_FS_SCL_LCNT_REG (0x50001320).....	218
Table 220: I2C_INTR_STAT_REG (0x5000132C) .....	218
Table 221: I2C_INTR_MASK_REG (0x50001330) .....	220
Table 222: I2C_RAW_INTR_STAT_REG (0x50001334).....	221
Table 223: I2C_RX_TL_REG (0x50001338).....	223
Table 224: I2C_TX_TL_REG (0x5000133C) .....	223
Table 225: I2C_CLR_INTR_REG (0x50001340) .....	223
Table 226: I2C_CLR_RX_UNDER_REG (0x50001344).....	223
Table 227: I2C_CLR_RX_OVER_REG (0x50001348) .....	224
Table 228: I2C_CLR_TX_OVER_REG (0x5000134C) .....	224
Table 229: I2C_CLR_RD_REQ_REG (0x50001350) .....	224
Table 230: I2C_CLR_TX_ABRT_REG (0x50001354) .....	224
Table 231: I2C_CLR_RX_DONE_REG (0x50001358).....	224



Table 232: I2C_CLR_ACTIVITY_REG (0x5000135C).....	225
Table 233: I2C_CLR_STOP_DET_REG (0x50001360) .....	225
Table 234: I2C_CLR_START_DET_REG (0x50001364) .....	225
Table 235: I2C_CLR_GEN_CALL_REG (0x50001368).....	225
Table 236: I2C_ENABLE_REG (0x5000136C).....	225
Table 237: I2C_STATUS_REG (0x50001370).....	226
Table 238: I2C_TXFLR_REG (0x50001374) .....	227
Table 239: I2C_RXFLR_REG (0x50001378).....	227
Table 240: I2C_SDA_HOLD_REG (0x5000137C).....	227
Table 241: I2C_TX_ABRT_SOURCE_REG (0x50001380).....	227
Table 242: I2C_DMA_CR_REG (0x50001388).....	229
Table 243: I2C_DMA_TDLR_REG (0x5000138C).....	229
Table 244: I2C_DMA_RDLR_REG (0x50001390).....	229
Table 245: I2C_SDA_SETUP_REG (0x50001394) .....	229
Table 246: I2C_ACK_GENERAL_CALL_REG (0x50001398).....	230
Table 247: I2C_ENABLE_STATUS_REG (0x5000139C).....	230
Table 248: I2C_IC_FS_SPKLEN_REG (0x500013A0).....	231
Table 249: Register map KBRD .....	232
Table 250: GPIO_IRQ0_IN_SEL_REG (0x50001400) .....	232
Table 251: GPIO_IRQ1_IN_SEL_REG (0x50001402) .....	233
Table 252: GPIO_IRQ2_IN_SEL_REG (0x50001404) .....	233
Table 253: GPIO_IRQ3_IN_SEL_REG (0x50001406) .....	233
Table 254: GPIO_IRQ4_IN_SEL_REG (0x50001408) .....	233
Table 255: GPIO_DEBOUNCE_REG (0x5000140C) .....	233
Table 256: GPIO_RESET_IRQ_REG (0x5000140E) .....	233
Table 257: GPIO_INT_LEVEL_CTRL_REG (0x50001410).....	234
Table 258: KBRD_IRQ_IN_SEL0_REG (0x50001412) .....	234
Table 259: KBRD_CTRL_REG (0x50001414) .....	235
Table 260: Register map crg2632_preg_aon_00.....	236
Table 261: HWR_CTRL_REG (0x50000300) .....	236
Table 262: RESET_STAT_REG (0x50000304) .....	236
Table 263: RAM_LPMX_REG (0x50000308).....	236
Table 264: PAD_LATCH_REG (0x5000030C).....	237
Table 265: HIBERN_CTRL_REG (0x50000310) .....	237
Table 266: POWER_AON_CTRL_REG (0x50000320) .....	237
Table 267: GP_DATA_REG (0x50000324).....	238
Table 268: Register map OTPC .....	239
Table 269: OTPC_MODE_REG (0x07F40000) .....	239
Table 270: OTPC_STAT_REG (0x07F40004) .....	240
Table 271: OTPC_PADDR_REG (0x07F40008) .....	241
Table 272: OTPC_PWORD_REG (0x07F4000C).....	242
Table 273: OTPC_TIM1_REG (0x07F40010).....	242
Table 274: OTPC_TIM2_REG (0x07F40014).....	243
Table 275: OTPC_AHBADR_REG (0x07F40018) .....	243
Table 276: OTPC_CELADR_REG (0x07F4001C).....	244
Table 277: OTPC_NWORDS_REG (0x07F40020).....	244
Table 278: Register map QDEC.....	245
Table 279: QDEC_CTRL_REG (0x50000200).....	245
Table 280: QDEC_XCNT_REG (0x50000202) .....	245
Table 281: QDEC_YCNT_REG (0x50000204) .....	245
Table 282: QDEC_CLOCKDIV_REG (0x50000206) .....	246
Table 283: QDEC_CTRL2_REG (0x50000208) .....	246
Table 284: QDEC_ZCNT_REG (0x5000020A).....	247
Table 285: QDEC_EVENT_CNT_REG (0x5000020C).....	247
Table 286: Register map rtc2632_00 .....	248
Table 287: RTC_CONTROL_REG (0x50004100) .....	248
Table 288: RTC_HOUR_MODE_REG (0x50004104) .....	248
Table 289: RTC_TIME_REG (0x50004108) .....	249
Table 290: RTC_CALENDAR_REG (0x5000410C).....	249

Table 291: RTC_TIME_ALARM_REG (0x50004110).....	249
Table 292: RTC_CALENDAR_ALARM_REG (0x50004114).....	250
Table 293: RTC_ALARM_ENABLE_REG (0x50004118).....	250
Table 294: RTC_EVENT_FLAGS_REG (0x5000411C).....	251
Table 295: RTC_INTERRUPT_ENABLE_REG (0x50004120).....	251
Table 296: RTC_INTERRUPT_DISABLE_REG (0x50004124).....	251
Table 297: RTC_INTERRUPT_MASK_REG (0x50004128).....	252
Table 298: RTC_STATUS_REG (0x5000412C).....	252
Table 299: RTC_KEEP_RTC_REG (0x50004130).....	253
Table 300: Register map SPI.....	254
Table 301: SPI_CTRL_REG (0x50001200).....	254
Table 302: SPI_CONFIG_REG (0x50001204).....	255
Table 303: SPI_CLOCK_REG (0x50001208).....	255
Table 304: SPI_FIFO_CONFIG_REG (0x5000120C).....	256
Table 305: SPI_IRQ_MASK_REG (0x50001210).....	256
Table 306: SPI_STATUS_REG (0x50001214).....	256
Table 307: SPI_FIFO_STATUS_REG (0x50001218).....	256
Table 308: SPI_FIFO_READ_REG (0x5000121C).....	257
Table 309: SPI_FIFO_WRITE_REG (0x50001220).....	257
Table 310: SPI_CS_CONFIG_REG (0x50001224).....	257
Table 311: SPI_FIFO_HIGH_REG (0x50001228).....	257
Table 312: SPI_TXBUFFER_FORCE_L_REG (0x5000122C).....	258
Table 313: SPI_TXBUFFER_FORCE_H_REG (0x50001230).....	258
Table 314: Register map Timer+3PWM.....	259
Table 315: TIMER0_CTRL_REG (0x50003400).....	259
Table 316: TIMER0_ON_REG (0x50003402).....	260
Table 317: TIMER0_RELOAD_M_REG (0x50003404).....	260
Table 318: TIMER0_RELOAD_N_REG (0x50003406).....	260
Table 319: TRIPLE_PWM_FREQUENCY (0x50003408).....	260
Table 320: PWM2_START_CYCLE (0x5000340A).....	260
Table 321: PWM3_START_CYCLE (0x5000340C).....	261
Table 322: PWM4_START_CYCLE (0x5000340E).....	261
Table 323: PWM5_START_CYCLE (0x50003410).....	261
Table 324: PWM6_START_CYCLE (0x50003412).....	261
Table 325: PWM7_START_CYCLE (0x50003414).....	261
Table 326: PWM2_END_CYCLE (0x50003416).....	261
Table 327: PWM3_END_CYCLE (0x50003418).....	262
Table 328: PWM4_END_CYCLE (0x5000341A).....	262
Table 329: PWM5_END_CYCLE (0x5000341C).....	262
Table 330: PWM6_END_CYCLE (0x5000341E).....	262
Table 331: PWM7_END_CYCLE (0x50003420).....	262
Table 332: TRIPLE_PWM_CTRL_REG (0x50003422).....	262
Table 333: Register map Timer1.....	264
Table 334: TIMER1_CTRL_REG (0x50004000).....	264
Table 335: TIMER1_CAPTURE_REG (0x50004004).....	264
Table 336: TIMER1_STATUS_REG (0x50004008).....	265
Table 337: TIMER1_CAPCNT1_VALUE_REG (0x5000400C).....	266
Table 338: TIMER1_CAPCNT2_VALUE_REG (0x50004010).....	266
Table 339: TIMER1_CLR_EVENT_REG (0x50004014).....	266
Table 340: Register map UART.....	267
Table 341: UART_RBR_THR_DLL_REG (0x50001000).....	269
Table 342: UART_IER_DLH_REG (0x50001004).....	270
Table 343: UART_IIR_FCR_REG (0x50001008).....	272
Table 344: UART_LCR_REG (0x5000100C).....	273
Table 345: UART_MCR_REG (0x50001010).....	274
Table 346: UART_LSR_REG (0x50001014).....	275
Table 347: UART_MSR_REG (0x50001018).....	278
Table 348: UART_SCR_REG (0x5000101C).....	278
Table 349: UART_SRBR_STHR0_REG (0x50001030).....	278

Table 350: UART_SRBR_STHR1_REG (0x50001034).....	279
Table 351: UART_SRBR_STHR2_REG (0x50001038).....	280
Table 352: UART_SRBR_STHR3_REG (0x5000103C).....	280
Table 353: UART_SRBR_STHR4_REG (0x50001040).....	281
Table 354: UART_SRBR_STHR5_REG (0x50001044).....	282
Table 355: UART_SRBR_STHR6_REG (0x50001048).....	283
Table 356: UART_SRBR_STHR7_REG (0x5000104C).....	283
Table 357: UART_SRBR_STHR8_REG (0x50001050).....	284
Table 358: UART_SRBR_STHR9_REG (0x50001054).....	285
Table 359: UART_SRBR_STHR10_REG (0x50001058).....	286
Table 360: UART_SRBR_STHR11_REG (0x5000105C).....	286
Table 361: UART_SRBR_STHR12_REG (0x50001060).....	287
Table 362: UART_SRBR_STHR13_REG (0x50001064).....	288
Table 363: UART_SRBR_STHR14_REG (0x50001068).....	289
Table 364: UART_SRBR_STHR15_REG (0x5000106C).....	289
Table 365: UART_FAR_REG (0x50001070).....	290
Table 366: UART_USR_REG (0x5000107C).....	290
Table 367: UART_TFL_REG (0x50001080).....	291
Table 368: UART_RFL_REG (0x50001084).....	292
Table 369: UART_SRR_REG (0x50001088).....	292
Table 370: UART_SRTS_REG (0x5000108C).....	292
Table 371: UART_SBCR_REG (0x50001090).....	293
Table 372: UART_SDMAM_REG (0x50001094).....	293
Table 373: UART_SFE_REG (0x50001098).....	293
Table 374: UART_SRT_REG (0x5000109C).....	294
Table 375: UART_STET_REG (0x500010A0).....	294
Table 376: UART_HTX_REG (0x500010A4).....	295
Table 377: UART_DMASA_REG (0x500010A8).....	295
Table 378: UART_DLF_REG (0x500010C0).....	295
Table 379: UART_UCV_REG (0x500010F8).....	295
Table 380: UART_UCV_HIGH_REG (0x500010FA).....	295
Table 381: UART_CTR_REG (0x500010FC).....	295
Table 382: UART_CTR_HIGH_REG (0x500010FE).....	296
Table 383: UART2_RBR_THR_DLL_REG (0x50001100).....	296
Table 384: UART2_IER_DLH_REG (0x50001104).....	297
Table 385: UART2_IIR_FCR_REG (0x50001108).....	298
Table 386: UART2_LCR_REG (0x5000110C).....	300
Table 387: UART2_MCR_REG (0x50001110).....	301
Table 388: UART2_LSR_REG (0x50001114).....	301
Table 389: UART2_SCR_REG (0x5000111C).....	303
Table 390: UART2_SRBR_STHR0_REG (0x50001130).....	303
Table 391: UART2_SRBR_STHR1_REG (0x50001134).....	304
Table 392: UART2_SRBR_STHR2_REG (0x50001138).....	305
Table 393: UART2_SRBR_STHR3_REG (0x5000113C).....	306
Table 394: UART2_SRBR_STHR4_REG (0x50001140).....	306
Table 395: UART2_SRBR_STHR5_REG (0x50001144).....	307
Table 396: UART2_SRBR_STHR6_REG (0x50001148).....	308
Table 397: UART2_SRBR_STHR7_REG (0x5000114C).....	309
Table 398: UART2_SRBR_STHR8_REG (0x50001150).....	309
Table 399: UART2_SRBR_STHR9_REG (0x50001154).....	310
Table 400: UART2_SRBR_STHR10_REG (0x50001158).....	311
Table 401: UART2_SRBR_STHR11_REG (0x5000115C).....	312
Table 402: UART2_SRBR_STHR12_REG (0x50001160).....	312
Table 403: UART2_SRBR_STHR13_REG (0x50001164).....	313
Table 404: UART2_SRBR_STHR14_REG (0x50001168).....	314
Table 405: UART2_SRBR_STHR15_REG (0x5000116C).....	315
Table 406: UART2_FAR_REG (0x50001170).....	315
Table 407: UART2_USR_REG (0x5000117C).....	316
Table 408: UART2_TFL_REG (0x50001180).....	317



Table 409: UART2_RFL_REG (0x50001184).....	317
Table 410: UART2_SRR_REG (0x50001188).....	317
Table 411: UART2_SBCR_REG (0x50001190).....	318
Table 412: UART2_SDMAM_REG (0x50001194).....	318
Table 413: UART2_SFE_REG (0x50001198).....	318
Table 414: UART2_SRT_REG (0x5000119C).....	319
Table 415: UART2_STET_REG (0x500011A0).....	319
Table 416: UART2_HTX_REG (0x500011A4).....	319
Table 417: UART2_DMASA_REG (0x500011A8).....	320
Table 418: UART2_DLF_REG (0x500011C0).....	320
Table 419: UART2_UCV_REG (0x500011F8).....	320
Table 420: UART2_UCV_HIGH_REG (0x500011FA).....	320
Table 421: UART2_CTR_REG (0x500011FC).....	320
Table 422: UART2_CTR_HIGH_REG (0x500011FE).....	320
Table 423: Register map Version.....	322
Table 424: CHIP_ID1_REG (0x50003200).....	322
Table 425: CHIP_ID2_REG (0x50003204).....	322
Table 426: CHIP_ID3_REG (0x50003208).....	322
Table 427: CHIP_ID4_REG (0x5000320C).....	322
Table 428: Register map WKUP.....	323
Table 429: WKUP_CTRL_REG (0x50000100).....	323
Table 430: WKUP_COMPARE_REG (0x50000102).....	323
Table 431: WKUP_IRQ_STATUS_REG (0x50000104).....	324
Table 432: WKUP_COUNTER_REG (0x50000106).....	324
Table 433: WKUP_SELECT_GPIO_REG (0x50000108).....	324
Table 434: WKUP2_SELECT_GPIO_REG (0x5000010A).....	324
Table 435: WKUP_POL_GPIO_REG (0x5000010C).....	324
Table 436: WKUP2_POL_GPIO_REG (0x5000010E).....	325
Table 437: Register map WDOG.....	326
Table 438: WATCHDOG_REG (0x50003100).....	326
Table 439: WATCHDOG_CTRL_REG (0x50003102).....	326
Table 440: Ordering Information (Samples).....	328
Table 441: Ordering Information (Production).....	328
Table 442: MSL Classification.....	329

# 1 Block Diagram

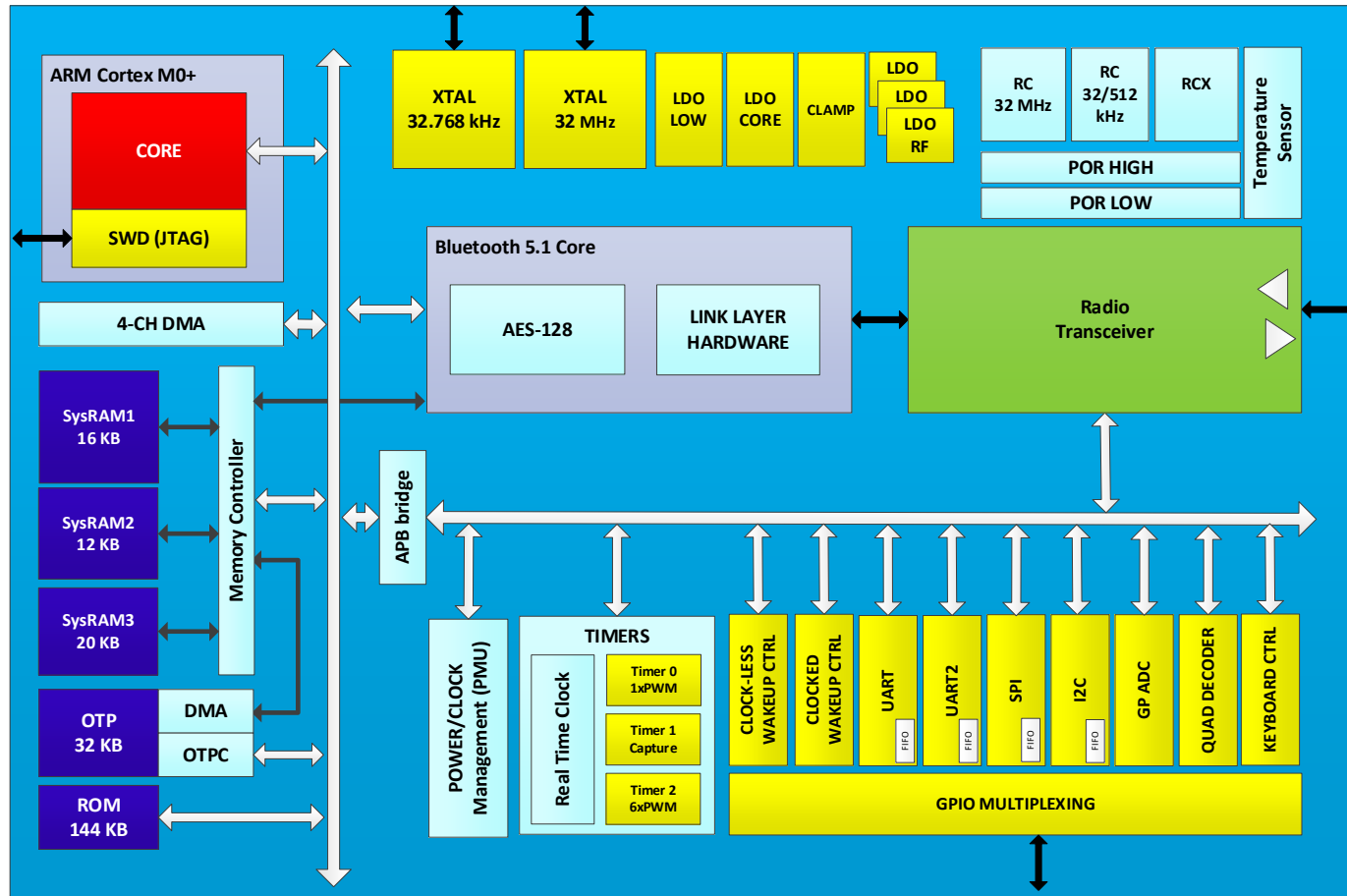

Figure 2: DA14530 Block Diagram

## 2 Package and Pinout

The DA14530 comes in a Quad Flat Package No Leads (FCGQFN) with 24 pins:

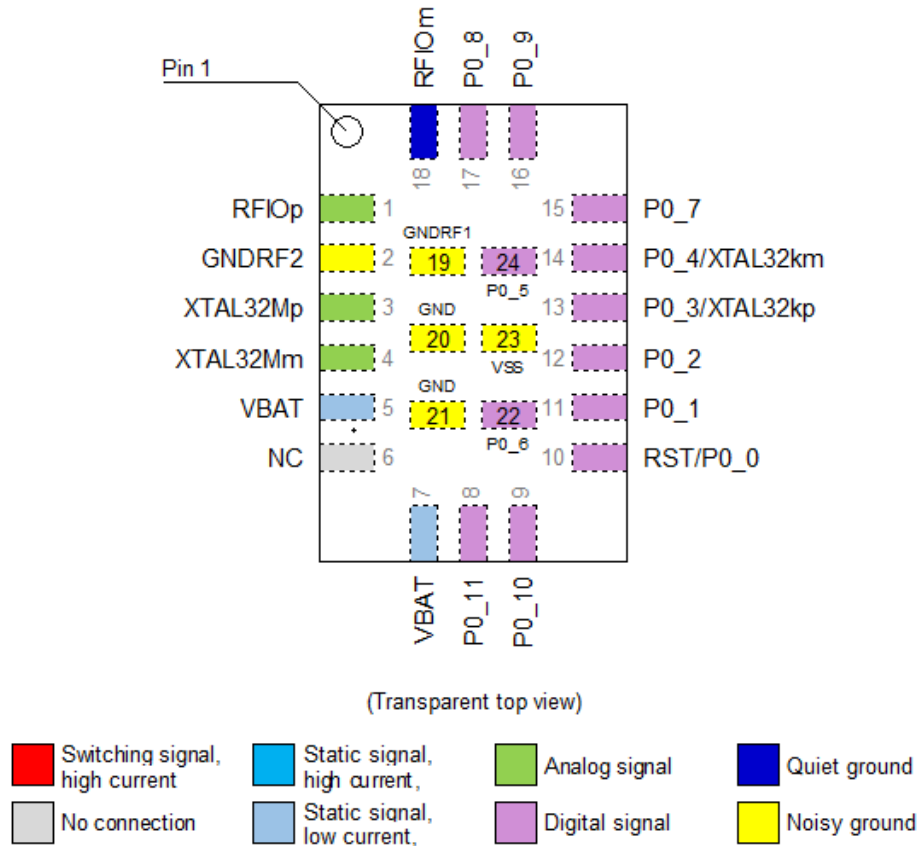

Figure 3: FCGQFN24 Pin Assignment (Top View)

Table 1: DA14530 FCGQFN24 Pin Description

Pin no.	Pin Name	Type	Reset State	Description
General Purpose I/Os (Note 3)				
10	P0_0	DIO (Type B)	I-PD	INPUT/OUTPUT with selectable pull up/down resistors. Pull-down enabled during and after reset. General purpose I/O port bit or alternate function nodes. Contains state retention mechanism during power down.
	RST	DIO (Type B)		RST active high hardware reset (default).
11	P0_1	DIO (Type B)	I-PD	INPUT/OUTPUT with selectable pull up/down resistors. Pull-down enabled during and after reset. General purpose I/O port bit or alternate function nodes. Contains state retention mechanism during power down.
	ADC0	AI		INPUT. Analog to Digital Converter input 0.

Pin no.	Pin Name	Type	Reset State	Description
12	P0_2	DIO (Type B)	I-PD	INPUT/OUTPUT with selectable pull up/down resistors. Pull-down enabled during and after reset. General purpose I/O port bit or alternate function nodes. Contains state retention mechanism during power down.
	ADC1	AI		INPUT. Analog to Digital Converter input 1.
	SWCLK	DIO		INPUT JTAG clock signal (by default).
13	P0_3	DIO (Type B)	I-PD	INPUT/OUTPUT with selectable pull up/down resistors. Pull-down enabled during and after reset. General purpose I/O port bit or alternate function nodes. Contains state retention mechanism during power down. Check GP_DATA_REG[P03_P04_FILT_DIS] for correct pad filter settings.
	XTAL32kp	AI		INPUT. Analog input of the XTAL32K crystal oscillator.
		DI		INPUT. Digital input for an external clock (square wave).
14	P0_4	DIO (Type B)	I-PD	INPUT/OUTPUT with selectable pull up/down resistors. Pull-down enabled during and after reset. General purpose I/O port bit or alternate function nodes. Contains state retention mechanism during power down. Check GP_DATA_REG[P03_P04_FILT_DIS] for correct pad filter settings.
	XTAL32km	AO		OUTPUT. Analog output of the XTAL32K crystal oscillator.
24	P0_5	DIO (Type B)	I-PD	INPUT/OUTPUT with selectable pull up/down resistors. Pull-down enabled during and after reset. General purpose I/O port bit or alternate function nodes. Contains state retention mechanism during power down.
22	P0_6	DIO (Type A)	I-PD	INPUT/OUTPUT with selectable pull up/down resistors. Pull-down enabled during and after reset. General purpose I/O port bit or alternate function nodes. Contains state retention mechanism during power down.
	ADC2	AI		INPUT. Analog to Digital Converter input 2.
15	P0_7	DIO (Type A)	I-PD	INPUT/OUTPUT with selectable pull up/down resistors. Pull-down enabled during and after reset. General purpose I/O port bit or alternate function nodes. Contains state retention mechanism during power down.
	ADC3	AI		INPUT. Analog to Digital Converter input 3.
17	P0_8	DIO (Type A)	I-PD	INPUT/OUTPUT with selectable pull up/down resistors. Pull-down enabled during and after reset. General purpose I/O port bit or alternate function nodes. Contains state retention mechanism during power down.
16	P0_9	DIO (Type A)	I-PD	INPUT/OUTPUT with selectable pull up/down resistors. Pull-down enabled during and after reset. General purpose I/O port bit or alternate function nodes.

Pin no.	Pin Name	Type	Reset State	Description
				Contains state retention mechanism during power down.
9	P0_10	DIO (Type A)	I-PD	INPUT/OUTPUT with selectable pull up/down resistors. Pull-down enabled during and after reset. General purpose I/O port bit or alternate function nodes. Contains state retention mechanism during power down.
	SWDIO	DIO		INPUT/OUTPUT. JTAG Data input/output. Bidirectional data and control communication (by default).
8	P0_11	DIO (Type A)	I-PD	INPUT/OUTPUT with selectable pull up/down resistors. Pull-down enabled during and after reset. General purpose I/O port bit or alternate function nodes. Contains state retention mechanism during power down.
<b>Debug Interface</b>				
9	SWDIO	DIO	I-PD	INPUT/OUTPUT. JTAG Data input/output. Bidirectional data and control communication. Mapped on P0_10 (by default).
12	SWCLK	DIO	I-PD	INPUT JTAG clock signal. Mapped on P0_2 (by default).
<b>Clocks</b>				
3	XTAL32Mp	AI		INPUT. Crystal input for the 32 MHz XTAL.
4	XTAL32Mm	AO		OUTPUT. Crystal output for the 32 MHz XTAL.
13	XTAL32kp	AI		INPUT. Crystal input for the 32.768 kHz XTAL. Mapped on P0_3.
14	XTAL32km	AO		OUTPUT. Crystal output for the 32.768 kHz XTAL. Mapped on P0_4.
<b>Quadrature Decoder</b>				
	QD_CHA_X	DI		INPUT. Channel A for the X axis. Mapped on Px ports.
	QD_CHB_X	DI		INPUT. Channel B for the X axis. Mapped on Px ports.
	QD_CHA_Y	DI		INPUT. Channel A for the Y axis. Mapped on Px ports.
	QD_CHB_Y	DI		INPUT. Channel B for the Y axis. Mapped on Px ports.
	QD_CHA_Z	DI		INPUT. Channel A for the Z axis. Mapped on Px ports.
	QD_CHB_Z	DI		INPUT. Channel B for the Z axis. Mapped on Px ports.
<b>SPI Bus Interface</b>				
	SPI_CLK	DO		INPUT/OUTPUT. SPI Clock. Mapped on Px ports.
	SPI_DI	DI		INPUT. SPI Data input. Mapped on Px ports ( <a href="#">Note 1</a> ).
	SPI_DO	DO		OUTPUT. SPI Data output. Mapped on Px ports ( <a href="#">Note 2</a> ).
	SPI_EN	DI/DO		INPUT/OUTPUT. SPI Clock enable. Mapped on Px ports.

Pin no.	Pin Name	Type	Reset State	Description
<b>I2C Bus Interface</b>				
	SDA	DIO/DIOD		INPUT/OUTPUT. I2C bus Data with open drain port. Mapped on Px ports. The mapped Px pin is automatically configured with a pull-up resistor (25KOhm) when pin x is mapped to the I2C_SDA PID function.
	SCL	DIO/DIOD		INPUT/OUTPUT. I2C bus Clock with open drain port. In open drain mode, SCL is monitored to support bit stretching by a slave. Mapped on Px ports. The mapped Px pin is automatically configured with a pull-up resistor (25KOhm) when pin x is mapped to the I2C_SCL PID function.
<b>UART Interface</b>				
	UTX	DO		OUTPUT. UART transmit data. Mapped on Px ports.
	URX	DI		INPUT. UART receive data. Mapped on Px ports.
	URTS	DO		OUTPUT. UART Request to Send. Mapped on Px ports.
	UCTS	DI		INPUT. UART Clear to Send. Mapped on Px ports.
	UTX2	DO		OUTPUT. UART2 transmit data. Mapped on Px ports.
	URX2	DI		INPUT. UART2 receive data. Mapped on Px ports.
<b>ADC IO Channels</b>				
11	ADC0	AI		INPUT. Analog to Digital Converter input 0. Mapped on P0_1.
12	ADC1	AI		INPUT. Analog to Digital Converter input 1. Mapped on P0_2.
22	ADC2	AI		INPUT. Analog to Digital Converter input 2. Mapped on P0_6.
15	ADC3	AI		INPUT. Analog to Digital Converter input 3. Mapped on P0_7.
<b>Radio Transceiver</b>				
1	RFIOp	AIO		RF input/output. Impedance 50 Ω.
18	RFIOm	AIO		RF ground.
19	GND_RF1	AIO		RF ground.
2	GND_RF2	AIO		RF ground.
<b>Miscellaneous</b>				
10	RST	DIO		INPUT. Reset signal (active high). Mapped on P0_0 (by default).
6	NC			No Connect
<b>Power and Ground</b>				
23	VSS	AIO		Digital ground.

Pin no.	Pin Name	Type	Reset State	Description
20, 21	GND	AIO		Analog ground.
5,7	VBAT	AIO		INPUT/OUTPUT. Battery connection. IO supply.

**Note 1** Data input only. MOSI in SPI slave mode and MISO in SPI master mode.

**Note 2** Data output only. MISO in SPI slave mode and MOSI in SPI master mode.

**Note 3** The differences between Type A and Type B GPIO pads are presented in [Types of GPIO Pads](#).

### 3 Specifications

All MIN/MAX specification limits are guaranteed by design, production testing and/or statistical characterization. Typical values are based on characterization results at default measurement conditions and are informative only.

Default measurement conditions (unless otherwise specified): VBAT = 3.0 V, T<sub>A</sub> = 25 °C. All radio measurements are performed with standard RF measurement equipment providing a source/load impedance of 50 Ω. All listed currents involving any radio operation have been conducted without the external CLC filter.



### 3.1 Absolute Maximum Ratings

**Table 2: Absolute Maximum Ratings**

Parameter	Description	Conditions	Min	Max	Unit
V <sub>BAT_LIM</sub>	limiting supply voltage		-0.2	3.6	V
V <sub>PIN_LIM_default</sub>	limiting voltage on a pin		-0.2	3.6	V
V <sub>ESD_HBM_FC</sub> GQFN24	electrostatic discharge voltage (Human Body Model)	RFIOm and RFIOp pins only up to 2.5 kV		4	kV
V <sub>ESD_CDM_FC</sub> GQFN24	electrostatic discharge voltage (Charged Device Model)			500	V
T <sub>STG</sub>	storage temperature		-50	150	°C

### 3.2 Recommended Operating Conditions

**Table 3: Recommended Operating Conditions**

Parameter	Description	Conditions	Min	Typ	Max	Unit
V <sub>BAT</sub>	Supply voltage	For OTP programming, a minimum voltage of 2.25V has to be provided. Also, allowed temperature range for programming is between -40 °C and 80 °C	1.8		3.3	V
V <sub>PIN_default_530</sub>	voltage on a pin		-0.2		V <sub>BAT</sub> +0.2	V
T <sub>A</sub>	ambient temperature		-40		85	°C

### 3.3 DC Characteristics

**Table 4: DC Characteristics**

Parameter	Description	Conditions	Min	Typ	Max	Unit
I <sub>BAT_HIBERN_0</sub> kB	battery supply current	Hibernation mode, no RAM retained, no oscillator running		280		nA
I <sub>BAT_HIBERN_0</sub> kB_5DEG	battery supply current	Hibernation mode at 5 °C, 0kB RAM retained, no oscillator running		150		nA
I <sub>BAT_HIBERN_4</sub> 8kB	battery supply current	Hibernation mode, 48kB RAM retained, no oscillator running		800		nA
I <sub>BAT_DP_SLP_0</sub> kB	battery supply current	Deep-sleep with 0 kB RAM retained, running on RCX		0.9		µA
I <sub>BAT_EX_SLP_2</sub> 0kB	battery supply current	Extended-sleep with 20 kB RAM retained, running on RCX		1.2		µA

Parameter	Description	Conditions	Min	Typ	Max	Unit
I <sub>BAT_EX_SLP_48kB</sub>	battery supply current	Extended-sleep with 48 kB RAM retained, running on RCX		1.6		μA
I <sub>BAT_ACT_RX</sub>	battery supply current	Application with Receiver Active, CPU idle at 16MHz		5		mA
I <sub>BAT_ACT_TX</sub>	battery supply current	Application with Pout = 0dBm, Power setting 9, Transmit continuous unmodulated output power, CPU idle at 16MHz		9		mA
I <sub>BAT_RUN_16MHz</sub>	battery supply current	CPU executing code from RAM running on XTAL32M oscillator at 16MHz		900		μA
I <sub>BAT_IDLE_16MHz</sub>	battery supply current	CPU in Wait-for-Interrupt (WFI) state running on XTAL32M oscillator at 16MHz		460		μA
I <sub>BAT_RST</sub>	battery supply current	Reset pin asserted		200		μA

### 3.4 Timing Characteristics

Table 5: Timing Characteristics

Parameter	Description	Conditions	Min	Typ	Max	Unit
t <sub>STA_HIBERNATION</sub>	startup time	Time from hibernation to the first executed code instruction..		0.2	0.4	ms
t <sub>STA_SLP</sub>	startup time	Time from GPIO toggle to the first executed code instruction. Applicable for both deep and extended sleep mode.	0.83		1.1	ms

### 3.5 RCX Oscillator

Table 6: RCX Oscillator - Timing Characteristics

Parameter	Description	Conditions	Min	Typ	Max	Unit
Δf <sub>RC</sub>	RCX oscillator frequency drift	100ms time slot		100	500	ppm
Δf <sub>RC</sub> /ΔV <sub>VBA_T_HIGH</sub>	Supply voltage dependency (V <sub>BAT_HIGH</sub> )		-500	80	500	ppm/V
Δf <sub>RC</sub> /ΔV <sub>VBA_T_LOW</sub>	Supply voltage dependency (V <sub>BAT_LOW</sub> )		-500	200	3000	ppm/V
f <sub>RCX</sub>	RCX oscillator frequency	at target fixed trim setting	13	15	17	kHz

Parameter	Description	Conditions	Min	Typ	Max	Unit
$\Delta f_{RC}/\Delta T_1$	Temperature dependency	temperature range -40°C to 85°C, RCX_BIAS at preferred value	-125		125	ppm/d eg
$\Delta f_{RC}/\Delta T_2$	Temperature dependency	temperature range -40°C to 105°C, RCX_BIAS at preferred value	-200		200	ppm/d eg

### 3.6 XTAL32MHz Oscillator

Table 7: XTAL32MHz Oscillator - Recommended Operating Conditions

Parameter	Description	Conditions	Min	Typ	Max	Unit
P <sub>DRV_MAX</sub>	maximum drive power	Note 1			100	μW
V <sub>CLK_EXT</sub>	external clock voltage	In case of external clock source on XTAL32Mp (XTAL32Mm floating or connected to mid-level 0.6 V)		0.9		V
φ <sub>N_EXT_32M</sub>	phase noise	f <sub>C</sub> = 50 kHz; in case of external clock source			-130	dBc/H z
Δf <sub>XTAL_TRIM</sub>	crystal frequency trim			2		ppm
f <sub>XTAL_32M</sub>	crystal oscillator frequency			32		MHz
Δf <sub>XTAL</sub>	crystal frequency tolerance	After optional trimming; including aging and temperature drift Note 2	-20		20	ppm
Δf <sub>XTAL_UNT</sub>	crystal frequency tolerance	Untrimmed; including aging and temperature drift Note 3	-40		40	ppm
ESR <sub>_1pF</sub>	equivalent series resistance	C <sub>0</sub> <1pF			200	Ω
ESR <sub>_3pF</sub>	equivalent series resistance	C <sub>0</sub> <3pF			80	Ω
ESR <sub>_5pF</sub>	equivalent series resistance	C <sub>0</sub> <5pF			50	Ω
C <sub>L</sub>	load capacitance	No external capacitors are required	4	6	8	pF

**Note 1** Select a crystal which can handle a drive level of at least this specification.

**Note 2** Using the internal varicaps a wide range of crystals can be trimmed to the required tolerance.

**Note 3** Maximum allowed frequency tolerance for compensation by the internal varicap trimming mechanism.

### 3.7 XTAL32kHz Oscillator

**Table 8: XTAL oscillator 32kHz - Recommended Operating Conditions**

Parameter	Description	Conditions	Min	Typ	Max	Unit
f <sub>CLK_EXT</sub>	external clock frequency	at pin 32KXTAL1/P0_3 in GPIO mode	10		100	kHz
f <sub>XTAL</sub>	crystal oscillator frequency		30	32.768	35	kHz
ESR	equivalent series resistance				100	kΩ
C <sub>L</sub>	load capacitance	No external capacitors are required for a 6 pF or 7 pF crystal.	6	7	9	pF
C <sub>0</sub>	shunt capacitance			1	2	pF
Δf <sub>XTAL</sub>	crystal frequency tolerance (including aging)	Timing accuracy is dominated by crystal accuracy. A much smaller value is preferred.	-250		250	ppm
P <sub>DRV_MAX</sub>	maximum drive power	Note 1	0.1			μW

**Note 1** Select a crystal that can handle a drive level of at least this specification.

**Table 9: XTAL oscillator 32kHz - Timing Characteristics**

Parameter	Description	Conditions	Min	Typ	Max	Unit
t <sub>STA_XTAL</sub>	crystal oscillator startup time	Typical application, time until 1000 clocks are detected.		100	300	ms

### 3.8 RC32MHz Oscillator

**Table 10: RC32MHz Oscillator - Timing Characteristics**

Parameter	Description	Conditions	Min	Typ	Max	Unit
f <sub>RC32M_TRIMMED</sub>	RC oscillator frequency	at target trimming	29	30.5	31.5	MHz

### 3.9 Digital I/O Characteristics

**Table 11: Digital Pad - Recommended Operating Conditions**

Parameter	Description	Conditions	Min	Typ	Max	Unit
I <sub>L_HIDRV</sub>	driving current - high mode			3.5		mA
I <sub>L_LODRV</sub>	driving current - low mode			0.35		mA
V <sub>IH</sub>	HIGH level input voltage	V <sub>DD</sub> =0.9V	0.7*V <sub>DD</sub>			V

Parameter	Description	Conditions	Min	Typ	Max	Unit
V <sub>IL</sub>	LOW level input voltage	V <sub>DD</sub> =0.9V			0.3*V <sub>DD</sub>	V

Table 12: Digital Pad - DC Characteristics

Parameter	Description	Conditions	Min	Typ	Max	Unit
I <sub>IH</sub>	HIGH level input current	V <sub>I</sub> =V <sub>BAT_HIGH</sub> =3.0V	-10		10	μA
I <sub>IL</sub>	LOW level input current	V <sub>I</sub> =V <sub>SS</sub> =0V	-10		10	μA
I <sub>IH_PD</sub>	HIGH level input current	V <sub>I</sub> =V <sub>BAT_HIGH</sub> =3.0V	60		180	μA
I <sub>IL_PU</sub>	LOW level input current	V <sub>I</sub> =V <sub>SS</sub> =0V, V <sub>BAT_HIGH</sub> =3.0V	-180		-60	μA
V <sub>OH</sub>	HIGH level output voltage	I <sub>O</sub> =3.5mA, V <sub>BAT_HIGH</sub> =1.7V	0.8*V <sub>BAT_HIGH</sub>			V
V <sub>OL</sub>	LOW level output voltage	I <sub>O</sub> =3.5mA, V <sub>BAT_HIGH</sub> =1.7V			0.2*V <sub>BAT_HIGH</sub>	V
V <sub>OH_LOWDRV</sub>	HIGH level output voltage	I <sub>O</sub> =0.3mA, V <sub>BAT_HIGH</sub> =1.7V	0.8*V <sub>BAT_HIGH</sub>			V
V <sub>OL_LOWDRV</sub>	LOW level output voltage	I <sub>O</sub> =0.3mA, V <sub>BAT_HIGH</sub> =1.7V			0.2*V <sub>BAT_HIGH</sub>	V
C <sub>IN</sub>	input capacitance			0.75		pF

Table 13: Digital Pad with LPF - DC Characteristics

Parameter	Description	Conditions	Min	Typ	Max	Unit
C <sub>IN</sub>	input capacitance	Note 1 Note 2		3.85		pF

**Note 1** Digital pad characteristics are equal to the standard GPIO pads unless overruled or added in this table.

**Note 2** P0\_3 and P0\_4 are type B pads with selectable filter via GP\_DATA\_REG[P03\_P04\_FILT\_DIS], C<sub>IN</sub> is equal to a Type A pad both with filter enabled or disabled.

Table 14: Digital Pad with LPF - Recommended Operating Conditions

Parameter	Description	Conditions	Min	Typ	Max	Unit
I <sub>L_HIDRV</sub>	driving current - high mode			3.5		mA
I <sub>L_LODRV</sub>	driving current - low mode			0.35		mA

### 3.10 Power On Reset

**Table 15: POR VBAT\_LOW - DC Characteristics**

Parameter	Description	Conditions	Min	Typ	Max	Unit
V <sub>TH_H</sub>	POR VBAT_LOW reset release voltage			1.05	1.1	V
V <sub>TH_L</sub>	POR VBAT_LOW reset activation voltage		0.95	1		V

**Table 16: POR VBAT\_HIGH - DC Characteristics**

Parameter	Description	Conditions	Min	Typ	Max	Unit
V <sub>TH_H</sub>	POR VBAT_HIGH reset release voltage			1.75	1.8	V
V <sub>TH_L</sub>	POR VBAT_HIGH reset activation voltage		1.62	1.66		V

### 3.11 GP ADC

**Table 17: GP ADC - Recommended Operating Conditions**

Parameter	Description	Conditions	Min	Typ	Max	Unit
N <sub>BIT_ADC</sub>	number of bits (resolution)			10		bit

**Table 18: GP ADC - DC Characteristics**

Parameter	Description	Conditions	Min	Typ	Max	Unit
E <sub>G</sub>	ADC gain error without software correction (single-ended)	Trimmed bandgap	-3		3	%
E <sub>G_COR</sub>	ADC gain error after software correction (single-ended)	Trimmed bandgap & Gain Error + Offset correction applied	-1		1	%
E <sub>OFS</sub>	ADC offset error without software correction (single-ended)	Trimmed bandgap, no chopping	-40		40	LSB
E <sub>OFS_COR</sub>	ADC offset error after software correction (single-ended)	Trimmed bandgap, chopping enabled & Gain Error + Offset correction applied	-4		4	LSB
E <sub>G_DIF</sub>	ADC gain error without software correction (differential)	Trimmed bandgap	-3		3	%
E <sub>G_DIF_COR</sub>	ADC gain error after software correction (differential)	Trimmed bandgap & Gain Error + Offset correction applied	-1		1	%

Parameter	Description	Conditions	Min	Typ	Max	Unit
E <sub>OFS_DIF</sub>	ADC offset error without software correction (differential)	Trimmed bandgap, no chopping	-20		20	LSB
E <sub>OFS_DIF_COR</sub>	ADC offset error after software correction (differential)	Trimmed bandgap, chopping enabled & Gain Error + Offset correction applied	-4		4	LSB
E <sub>G_ATTNX</sub>	ADC gain error after software correction (including attenuator)	Trimmed bandgap & GPADC Gain Error + Offset correction applied	-4		4	%
E <sub>OFS_ATTNX</sub>	ADC offset error after software correction (including attenuator)	Trimmed bandgap, chopping enabled & GPADC Gain Error + Offset correction applied	-16		16	LSB
E <sub>G_OFFSH</sub>	ADC gain error after software correction (including offset shifter)	Trimmed bandgap & Offset Shifter Gain Error + Offset correction applied	-1		1	%
E <sub>OFS_OFFSH</sub>	ADC offset error after software correction (including offset shifter)	Trimmed bandgap, chopping enabled & Offset Shifter Gain Error + Offset correction applied	-4		4	LSB
INL	integral non-linearity	Note 1	-2		2	LSB
DNL	differential non-linearity		-2		2	LSB
ENOB	Effective Number Of Bits	no averaging, no chopping, Single-Ended: V <sub>IN,PP</sub> = 800mV		9		bit
ENOB <sub>AVG128</sub>	Effective Number Of Bits	128x averaging, Single-Ended: V <sub>IN,PP</sub> = 800mV		11		bit

**Note 1** INL is the deviation of a code from a straight line passing through the actual endpoints of the transfer curve.

**Table 19: GP ADC - Electrical performance**

Parameter	Description	Conditions	Min	Typ	Max	Unit
t <sub>CONV_ADC</sub>	Conversion time of the ADC			125	500	ns

### 3.12 Temperature Sensor

**Table 20: Temperature Sensor - DC Characteristics**

Parameter	Description	Conditions	Min	Typ	Max	Unit
T <sub>SENSE_RANGE</sub>	Temperature sensor range		-40		105	°C
T <sub>SENSE_ACC_OTP_QFN_530</sub>	Applies to the QFN package. Absolute accuracy of temperature sensor using calibration value from OTP	T <sub>AMBIENT</sub> = 25°C		±4		°C

Parameter	Description	Conditions	Min	Typ	Max	Unit
	(single point calibration at 25°C) . Formula: $T_x = 25^{\circ}\text{C} + (\text{ADC}_x - \text{ADC}_{\text{OTP\_CAL\_25C}}) / (\text{TC}_{\text{SENSE}} * 64)$ (64 is used to correct 16b to 10b ADC values)					
TC <sub>SENSE</sub>	Temperature coefficient of the internal temperature sensor	reading via GP_ADC (10bit result)	1.15	1.45	1.75	LSB/°C

### 3.13 Radio

**Table 21: BLE 1Mb/s specifications - Recommended Operating Conditions**

Parameter	Description	Conditions	Min	Typ	Max	Unit
f <sub>OPER</sub>	operating frequency		2400		2483.5	MHz
N <sub>CH</sub>	number of channels			40		1
f <sub>CH</sub>	channel frequency	K = 0 to 39		2402+K*2		MHz

**Table 22: BLE 1Mb/s specifications - AC Characteristics**

Parameter	Description	Conditions	Min	Typ	Max	Unit
P <sub>SENS_CLEAN_530</sub>	sensitivity level	Dirty Transmitter disabled; PER = 30.8 %; <a href="#">Note 1</a>		-94		dBm
P <sub>SENS_EPKT</sub>	sensitivity level	Extended packet size (255 octets) <a href="#">Note 1</a>		-90.5		dBm
P <sub>SENS_530</sub>	sensitivity level	Normal Operating Conditions; PER = 30.8 %; <a href="#">Note 1</a>		-93		dBm
P <sub>SENS_EOC_530</sub>	sensitivity level	Extreme Operating Conditions; PER = 30.8 %; -40 °C ≤ T <sub>A</sub> ≤ +85 °C <a href="#">Note 1</a>			-90	dBm
P <sub>SENS_EPKT_CLEAN_530</sub>	sensitivity level	Dirty Transmitter disabled; Extended packet size (255 octets) <a href="#">Note 1</a>		-91.5		dBm
P <sub>I_MAX_530</sub>	maximum input power level	DC-DC converter disabled; PER = 30.8 %; <a href="#">Note 1</a>	0			dBm



Parameter	Description	Conditions	Min	Typ	Max	Unit
P <sub>INT_IMD</sub>	intermodulation distortion interferer power level	worst-case interferer level @ $f_1, f_2$ with $2*f_1 - f_2 = f_0$ , $ f_1 - f_2  = n$ MHz and $n = 3, 4, 5$ ; $P_{WANTED} = -64$ dBm @ $f_0$ ; PER = 30.8 %; <a href="#">Note 1</a>	-35	-20.5		dBm
CIR <sub>0</sub>	carrier to interferer ratio	$n = 0$ ; interferer @ $f_1 = f_0 + n*1$ MHz; <a href="#">Note 1</a>		7.5	21	dB
CIR <sub>1</sub>	carrier to interferer ratio	$n = \pm 1$ ; interferer @ $f_1 = f_0 + n*1$ MHz; <a href="#">Note 1</a>		-1.5	15	dB
CIR <sub>P2</sub>	carrier to interferer ratio	$n = +2$ (image frequency); interferer @ $f_1 = f_0 + n*1$ MHz; <a href="#">Note 1</a>		-27	-9	dB
CIR <sub>M2</sub>	carrier to interferer ratio	$n = -2$ ; interferer @ $f_1 = f_0 + n*1$ MHz; <a href="#">Note 1</a>		-31	-17	dB
CIR <sub>P3</sub>	carrier to interferer ratio	$n = +3$ (image frequency + 1 MHz); interferer @ $f_1 = f_0 + n*1$ MHz; <a href="#">Note 1</a>		-37.5	-15	dB
CIR <sub>M3</sub>	carrier to interferer ratio	$n = -3$ ; interferer @ $f_1 = f_0 + n*1$ MHz; <a href="#">Note 1</a>		-43	-27	dB
CIR <sub>4</sub>	carrier to interferer ratio	$ n  \geq 4$ (any other BLE channel); interferer @ $f_1 = f_0 + n*1$ MHz; <a href="#">Note 1</a>		-41.5	-27	dB
P <sub>BL_I</sub>	blocker power level	$30 \text{ MHz} \leq f_{BL} \leq 2000 \text{ MHz}$ ; $P_{WANTED} = -67$ dBm; <a href="#">Note 1</a>	-17	5		dBm
P <sub>BL_II</sub>	blocker power level <a href="#">Note 2</a>	$2003 \text{ MHz} \leq f_{BL} \leq 2399 \text{ MHz}$ ; $P_{WANTED} = -67$ dBm; <a href="#">Note 1</a>	-17	0		dBm
P <sub>BL_III</sub>	blocker power level	$2484 \text{ MHz} \leq f_{BL} \leq 2997 \text{ MHz}$ ; $P_{WANTED} = -67$ dBm; <a href="#">Note 1</a>	-17	0		dBm
P <sub>BL_IV</sub>	blocker power level	$3000 \text{ MHz} \leq f_{BL} \leq 12.75 \text{ GHz}$ ; $P_{WANTED} = -67$ dBm; <a href="#">Note 1</a>	-17	5		dBm
LACC_RSSI	level accuracy	tolerance at 5 % to 95 % confidence interval of $P_{RF}$ : when $RXRSSI[7:0] = X$ , $50 < X < 175$ ; burst mode, 1500 packets;		0	3	dB

Parameter	Description	Conditions	Min	Typ	Max	Unit
LRES_RSSI	level resolution	gradient of monotonous range for RXRSSI[7:0] = X, 50 < X < 175; burst mode, 1500 packets;		0.5		dB/LSB
ACP <sub>2M</sub>	adjacent channel power level	f <sub>OFFS</sub> = 2 MHz; Note 1		-53		dBm
ACP <sub>2M_EOC</sub>	adjacent channel power level	Extreme Operating Conditions; f <sub>OFFS</sub> = 2 MHz; -40 °C ≤ T <sub>A</sub> ≤ +85 °C Note 1		-53	-47	dBm
ACP <sub>3M</sub>	adjacent channel power level	f <sub>OFFS</sub> ≥ 3 MHz; Note 1		-57		dBm
ACP <sub>3M_EOC</sub>	adjacent channel power level	Extreme Operating Conditions; f <sub>OFFS</sub> ≥ 3 MHz; -40 °C ≤ T <sub>A</sub> ≤ +85 °C Note 1		-57	-47	dBm
P <sub>O_12</sub>	output power level	RF_ATTR_REG[PA_POWER_SETTING]= 12		2.5		dBm
P <sub>O_11</sub>	output power level	RF_ATTR_REG[PA_POWER_SETTING]= 11		1.5		dBm
P <sub>O_10</sub>	output power level	RF_ATTR_REG[PA_POWER_SETTING]= 10		1		dBm
P <sub>O_09</sub>	output power level	RF_ATTR_REG[PA_POWER_SETTING]= 9		0		dBm
P <sub>O_08</sub>	output power level	RF_ATTR_REG[PA_POWER_SETTING]= 8		-1		dBm
P <sub>O_07</sub>	output power level	RF_ATTR_REG[PA_POWER_SETTING]= 7		-2		dBm
P <sub>O_06</sub>	output power level	RF_ATTR_REG[PA_POWER_SETTING]= 6		-3.5		dBm
P <sub>O_05</sub>	output power level	RF_ATTR_REG[PA_POWER_SETTING]= 5		-5		dBm
P <sub>O_04</sub>	output power level	RF_ATTR_REG[PA_POWER_SETTING]= 4		-7		dBm
P <sub>O_03</sub>	output power level	RF_ATTR_REG[PA_POWER_SETTING]= 3		-10		dBm
P <sub>O_02</sub>	output power level	RF_ATTR_REG[PA_POWER_SETTING]= 2		-13.5		dBm
P <sub>O_01</sub>	output power level	RF_ATTR_REG[PA_POWER_SETTING]= 1		-19.5		dBm

**Note 1** Measured according to Bluetooth® Low Energy Test Specification RF-PHY.TS/5.1.0

**Note 2** Frequencies close to the ISM band can show slightly worse performance

Table 23: BLE 1Mb/s specifications - Timing Characteristics

Parameter	Description	Conditions	Min	Typ	Max	Unit
t <sub>HOLD</sub>	hold time of radio Ido's	temperature from -40C to 55C	500			ms
t <sub>HOLD_EOC</sub>	hold time of the radio Ido's	temperature from -40C to 85C	10			ms

Table 24: BLE 1Mb/s specifications - DC Characteristics

Parameter	Description	Conditions	Min	Typ	Max	Unit
I <sub>BAT_RF_RX_530</sub>	Current at V <sub>BAT</sub> = 1.1V	radio receiver and synthesizer active; T <sub>A</sub> = 25 °C		4.3		mA
I <sub>BAT_RF_TX_12_530</sub>	Current at V <sub>BAT</sub> = 1.1V	radio transmitter and synthesizer active; power setting = 12; P <sub>OUT</sub> = 2.5dBm; T <sub>A</sub> = 25 °C		7.9		mA
I <sub>BAT_RF_TX_9_530</sub>	Current at V <sub>BAT</sub> = 1.1V	radio transmitter and synthesizer active; power setting = 9; P <sub>OUT</sub> = 0dBm; T <sub>A</sub> = 25 °C		6.9		mA
I <sub>BAT_RF_TX_6_530</sub>	Current at V <sub>BAT</sub> = 1.1V	radio transmitter and synthesizer active; power setting = 6; P <sub>OUT</sub> = -3.5dBm; T <sub>A</sub> = 25 °C		5.7		mA

## 4 System Overview

### 4.1 Internal Blocks

The DA14530 contains the following blocks:

**Arm Cortex-M0+ CPU with Wake-up Interrupt Controller (WIC).** This processor provides 0.9 dMIPS/MHz and is used for assisting the BLE protocol implementation, for providing processing power for calculations or data fetches required by applications, and for housekeeping, including controlling the power scheme of the system.

**BLE core.** This is the baseband hardware accelerator for the BLE protocol.

**ROM.** This 144-kB ROM contains the BLE protocol stack and the boot code sequence.

**OTP.** This 32-kB OTP memory array is used to store application code and BLE profiles. It also contains the system configuration and calibration data.

**System SRAM (SysRAM).** This 48-kB SysRAM is primarily used to mirror the program code from the OTP when the system wakes/powers up. It also serves as a Data RAM for intermediate variables and various data that the protocol requires. It can be used as an extra memory space for the BLE TX and RX data structures (Exchange RAM). The SysRAM cells can not only be retained during sleep modes but also be completely switched off during active mode if not needed.

**UART and UART2.** The serial interface of the UART implements hardware flow control while UART2 does not. Both UARTs feature FIFOs with depths of 16 bytes each.

**SPI.** This is the serial peripheral interface (SPI) with master/slave capability and it has a separate FIFOs for RX and TX of two 16-bit words each.

**I2C.** This Master/Slave I2C interface is used for sensors and/or host Micro-Controllers Units (MCUs) communication. It comprises a 32-place 9-bit deep FIFO.

**General Purpose (GP) ADC.** This 10-bit analog-to-digital converter (ADC) has four external input channels (GPIOs) and internal channels for reading die temperature, the battery voltage, and other internal analog nodes.

**Radio Transceiver.** This block implements the RF part of the BLE protocol.

**Clock Generator.** This block is responsible for clocking the system. It contains two XTAL oscillators, one running at 32 MHz (XTAL32M) and used for the active mode of the system and the other running at 32.768 kHz (XTAL32K) and used for the sleep modes of the system. There are also three RC oscillators available: a 32 MHz oscillator (RC32M) with low precision (> 500 ppm), a 32 kHz oscillator (RC32K) with low precision (> 500 ppm), and a ~15 kHz oscillator (RCX) with high precision (< 500 ppm). The RCX oscillator can be used as a sleep clock to replace the XTAL32K oscillator to further improve the power dissipation of the system while reducing the bill of materials. The RC32M oscillator is used to provide a clock to mirror the OTP code into the SysRAM while the XTAL32M oscillator is settling directly after power/wake up. This clock is also used to run the Booter at power-up. An external digital clock can be used as a sleep clock to replace the XTAL32K or the RCX oscillator.

**Timers.** This block contains three timers:

- A 16-bit general purpose timer (Timer0) with two pulse width modulation (PWM) signals (PWM1 is inverted to PWM0)
- A 11-bit timer (Timer1) with two capture channels
- A 14-bit timer (Timer2) which controls six PWM signals that all have the same frequency, but each has a configurable duty cycle

**Real Time Clock (RTC).** This hardware controller supports the complete time of day clock: 12/24 hours, minutes, seconds, milliseconds, and hundredths of a millisecond. It includes a configurable alarm function and can be programmed to generate an interrupt on any event, like a rollover of month, day, hour, minute, second, or hundredths of a millisecond.

**Wake-Up Timer.** This timer captures external events and it can be used on any of the GPIO ports as a wake-up trigger based on a programmable number of external events.

**Quadrature Decoder.** This block decodes the pulse trains from a rotary encoder to provide the step and the direction of a movement of an external device. Three axes (X, Y, and Z) are supported. The block also supports an edge counting mode which enables counting positive or negative edges on the selected GPIOs.

**Keyboard Controller.** This circuit enables the reading and debouncing of a programmable number of GPIOs and generates an interrupt upon a configurable action.

**AHB/APB Bus.** This block implements the AMBA Lite version of the AHB and APB specifications.

**Power Management.** The power management circuit is equipped with several low-dropout regulators (LDOs) that can be turned on/off via software.

A more detailed description of each component of the DA14530 is presented in the following sections.

## 4.2 Power Management Unit

### 4.2.1 Introduction

The DA14530 has an integrated power management unit (PMU) which comprises a VDD\_Clamp, a POR circuitry and various LDOs. The system diagram of the integrated PMU is shown in [Error! Reference source not found.](#)

#### Features

- Active and sleep mode LDOs
- Low BOM and use of small external components

### 4.2.2 Architecture

The PMU integrates two internal  $V_{BAT}$  and a  $V_{DD}$  power rail.

- $V_{BAT}$  with a voltage range of minimum 2.3 V up to 3.3 V. The minimum voltage is dictated by the capability of OTP being programmed in the field. If OTP programming is not required, then the minimum battery voltage will be 1.8V which is needed to be able to read from the OTP memory
- The internal  $V_{DD}$  power rail supplies the digital power domains (refer to section [4.2.2.1 for the details](#))

The PMU block diagram is presented in [Figure 4](#). Note that, GPIOs supply follows the battery voltage.

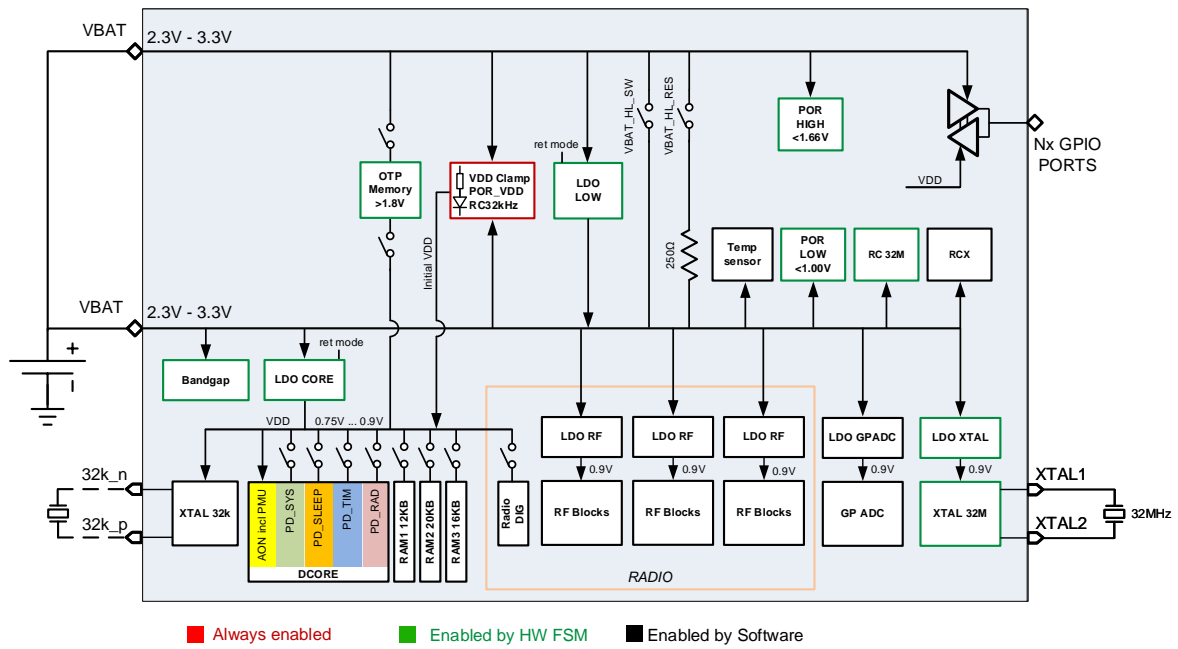

Figure 4: Power Management Unit: Bypass Configuration

#### 4.2.2.1 Digital Power Domains

The DA14530 supports a number of digital power domains that can be turned on and off by software (Figure 5). Some of the blocks contain registers that can retain their values even if the digital power domain where they reside is powered off. RAM cells can retain their contents independently from the digital power domains state.

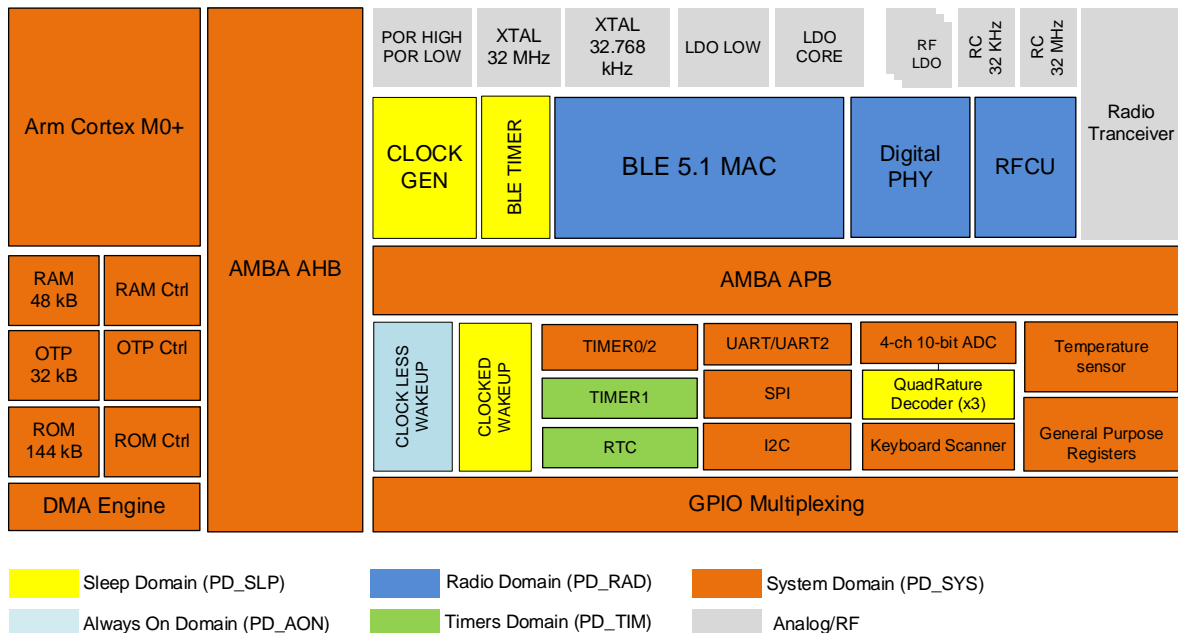

Figure 5: Digital Power Domains

The list of blocks residing in each one of the digital power domains is presented in Table 25.

Table 25: Power Domains Description

Domain Name	Description
PD_AON	Always powered domain. It contains a Clock-less Wake Up controller and the pad-ring.
PD_SLP	Sleep power domain. It comprises the Arm/WIC, the BLE Timer, the PMU/Clock Generation, the Clocked Wakeup Controller, the Quadrature Decoder, and various registers required for the Wake-Up sequence.
PD_SYS	System Power Domain. It comprises the AHB bus, the OTP cell and controllers, the ROM, the System RAM, the Watchdog, the SW Timer, and the GPIO port multiplexing.
PD_TIM	Timer Power Domain. It comprises the RTC and the Timer1. These two blocks can be active during sleep modes.
PD_RAD	Radio Power Domain. It comprises the BLE Core and the digital PHY of the Radio.

#### 4.2.2.2 Power Modes

There are five different power modes in the DA14530:

- **Active mode:** System is active and operates at full speed
- **Sleep mode:** No power gating has been programmed. The Cortex CPU is idle, waiting for an interrupt. PD\_SYS is on. PD\_TIM and PD\_RAD depend on the programmed enabled value
- **Extended Sleep mode:** PD\_AON, PD\_SLP, and conditionally PD\_TIM are active. RAM is expected to be retained for
  - Keeping a BLE connection alive (stack variables or BLE data)
  - Potentially keep the application code and it can be omitted if the OTP is instructed to automatically get mirrored into RAM upon every wake up
- **Deep Sleep mode:** Shipping clocked mode with all domains disabled. RAM may or may not be retained. RTC operation is programmable
- **Hibernation mode:** Shipping clock-less mode with all domains disabled. RAM may or may not be retained. No clock is running

A summary of the power modes, the digital power domains, as well as the clocks and wake-up capabilities are explained in [Table 26](#).

Table 26: Power Modes, Digital Power Domains, Clocks, and Wake-up triggers

Power Mode	Digital Power Domains	LDOs and VDD Level	Clock Availability	RAM	Wake Up from
Active or Sleep (WFI)	PD_AON = ON PD_SLP = ON PD_SYS = ON PD_TIM = OPTIONAL PD_RAD = OPT	VDD = 0.9 V LDO_LOW = OFF LDO_CORE = ON, Active (0.9 V) VDD_Clamp = OFF LDO_RADIO = Programmable	All	SysRAM1 = ON (Application) SysRAM2 = optionally retained SysRAM3 = ON (Stack Data)	
Extended Sleep (with or without OTP)	PD_AON = ON PD_SLP = ON PD_SYS = OFF PD_TIM = OPTIONAL PD_RAD = OFF	VDD = 0.75 V LDO_LOW = OFF LDO_CORE = ON, in retain mode (0.75 V) VDD_Clamp = OFF LDO_RADIO = OFF	RCX or XTAL32K	SysRAMx = optionally retained (typically only SysRAM1 is retained)	<ul style="list-style-type: none"> <li>• RTC alarm</li> <li>• Timer1</li> <li>• BLE sleep timer</li> </ul>
Deep Sleep	PD_AON = ON PD_SLP = ON PD_SYS = OFF PD_TIM = OPTIONAL PD_RAD = OFF	VDD = 0.75 V LDO_LOW = OFF LDO_CORE = ON, in retain mode (0.75 V) VDD_Clamp = OFF LDO_RADIO = OFF	RCX or XTAL32K	SysRAMx = optionally retained (Typically OFF)	<ul style="list-style-type: none"> <li>• from any GPIOs</li> <li>• RTC alarm</li> <li>• Timer1</li> </ul>
Hibernation	PD_AON = ON PD_SLP = OFF PD_SYS = OFF PD_TIM = OFF PD_RAD = OFF	VDD = ~0.75 V LDO_LOW = OFF LDO_CORE = OFF VDD_Clamp = ~0.75 V LDO_RADIO = OFF	No Clocks	SysRAMx = optionally retained	Wake up from P0_1, P0_2, P0_3, P0_4, P0_5



#### 4.2.2.3 VDD Level in Hibernation

While in Hibernation, the Always On domain (PD\_AON) is supplied by a clamp. Since the reference is not enabled, the actual voltage supplied by the clamp is depending on the load and temperature. To ensure proper operation of the PD\_AON across the application operating temperature range and load, it is recommended to configure the voltage level of the VDD\_Clamp using POWER\_AON\_CTRL\_REG[LDO\_RET\_TRIM] according to the following table:

**Table 27: VDD\_Clamp recommended settings over temperature and load**

Temperature Range	0kB retained RAM	48kB retained RAM
-40°C to +40°C	0xE	0xD
-40°C to +60°C	0xD	0xC
-40°C to +85°C	0xB	0xA

#### 4.2.2.4 Retainable Registers

When the system enters one of the sleep modes, some registers need to retain their values even though their power domain might be shut down. These special retainable registers and their power domains are described in [Table 28](#).

**Table 28: Retainable Registers**

Power Domains	Retainable Registers
PD_SYS	OTPC_MODE_REG
	OTPC_TIM1_REG
	OTPC_TIM2_REG
	OTPC_AHBADR_REG
	OTPC_CELADR_REG
	OTPC_NWORDS_REG
	DEBUG_REG
PD_RAD	BLE_CNTL2_REG
	RF_ADCI_DC_OFFSET_REG
	RF_ADCQ_DC_OFFSET_REG
	RF_DC_OFFSET_RESULT_REG
	RF_DC_OFFSET_FULL_RES_REG
	RF_DC_OFFSET_MPAR_RES0/1/2/3_REG

#### 4.2.3 Programming

Initial voltage at VBAT has to be above 1.8 V to allow the OTP to be read and mirrored. Software can disable LDO\_LOW to reduce quiescent current. The following register settings are required to accomplish this:

- POWER\_CTRL\_REG[LDO\_LOW\_CTRL\_REG] = 0x1

If voltage drops below 1.75 V, POR\_HIGH must be masked in order to prevent unnecessary resets. Note that OTP reads cannot be performed after this point. Masking POR\_HIGH is done by the following setting:

- POWER\_AON\_CTRL\_REG[POR\_VBAT\_HIGH\_RST\_MASK] = 0x1

When POR\_HIGH is masked, its status remains available, but it will not generate a reset. POR\_HIGH can be also disabled by the following setting:

- POWER\_CTRL\_REG[POR\_VBAT\_HIGH\_DISABLE] = 0x1

When POR\_HIGH is disabled, its status becomes unavailable.

### 4.3 HW FSM (Power-up, Wake-up, and Go-to-Sleep)

The HW Finite State Machine (FSM) responsible for the power-up, wake-up, and go-to-sleep processes of the system is presented in Figure 6.

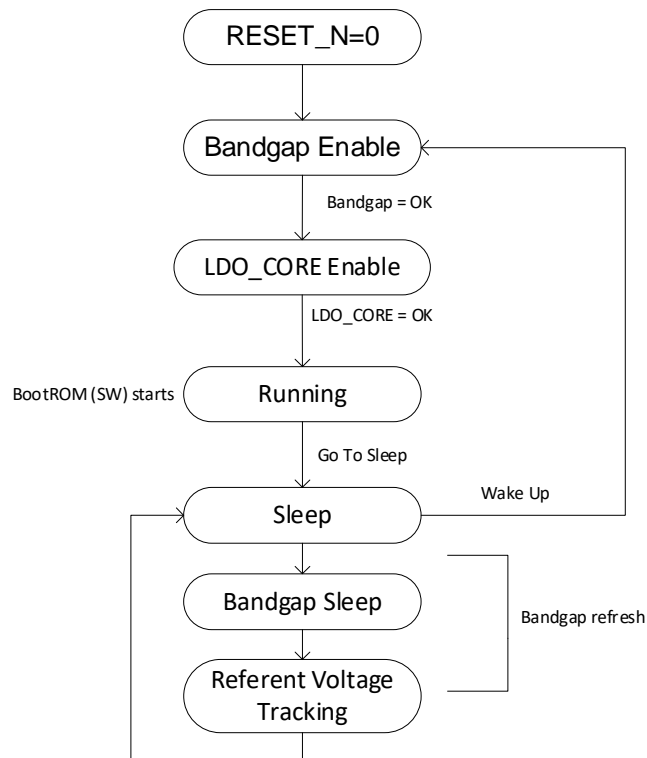

**Figure 6: Power-Up/Wake-Up/Sleep FSM Diagram**

The details of the wake-up, and sleep sequences of the FSM for the different modes are described in the following paragraphs.

To wake up from hibernation, one of the designated GPIOs has to be triggered. A synchronization phase of at least 3 RC32KHz cycles is needed before the bandgap is enabled and the clock switches in fast mode. In the next step the LDO\_CORE is enabled and then the system reset can be released for the Booter to start running. The total time needed to wake up the system from hibernation up until booter software starts running is around 180  $\mu$ s.

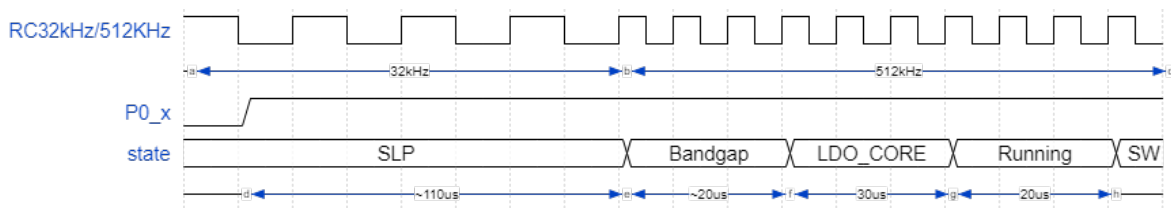

**Figure 7: Power up/Wake-Up from hibernation**

In the wake-up sequence from deep or extended sleep using a GPIO toggle, the timing is presented in Figure 8. The total time which is needed to power up the system up until software starts running is

around 865  $\mu$ s. If RAM has been retained, running software means application; if not then the Booter will be started.

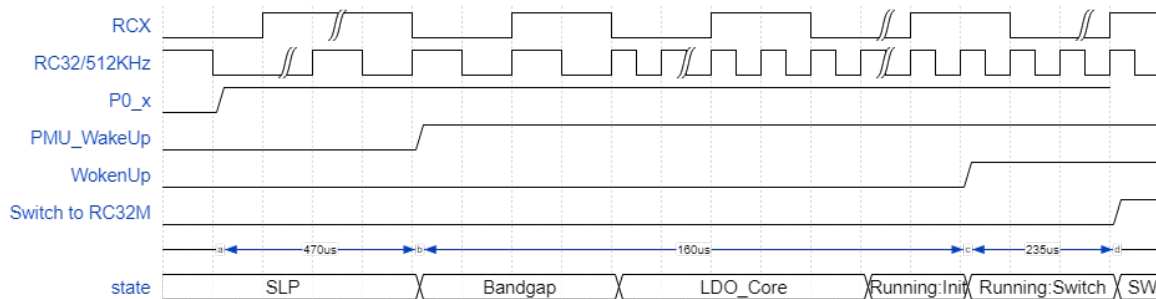

**Figure 8: Wake-Up from extended/deep sleep**

A GPIO trigger will have to go through the wake up controller first, which requires 7 RCX clock cycles before it is allowed to trigger the PMU and have the state machine running. Even after all power rails are done, switching the system clock from RCX into RC32M (so software starts running) takes 3.5 RCX clock cycles (indicated in state=RUNNING:SWITCH) in the figure above.

If the system wakes up from an internal timer running at the RCX clock, then the WokenUp signal will be asserted 6 RCX clock cycles after the timer generates the interrupt (i.e ~400usec).

#### 4.3.1 Go-to-Sleep and Refresh Bandgap

The sleep state disables the power-consuming blocks and triggers the "hold mode" for the bandgap referenced voltages. After a certain amount of time (sleep refresh counter), these "hold" voltages need to be refreshed. The lower loop of the FSM in [Figure 6](#) enables the bandgap, refreshes the voltages, checks for BOD events via the POR circuits and if ok, resets the refresh timer and goes back to sleep. This is an autonomous cycle led by hardware until the system is woken up by a wake-up event. The refresh timer can be configured by setting the PMU\_SLEEP\_REG [BG\_REFRESH\_INTERVAL] bit field (1 LSB = 64 x 32 kHz clock cycles). The go-to-sleep and the bandgap refresh sequence is shown in [Figure 9](#).

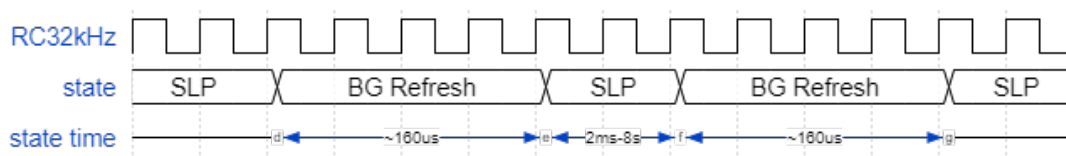

**Figure 9: Go-to-Sleep and Bandgap Refresh**

#### 4.4 OTP Memory Layout

The OTP memory has to be programmed according to a specific layout, which structures information to be easily accessible from the BootROM code as well as the actual application. An overview of the layout scheme is presented in [Figure 10](#).

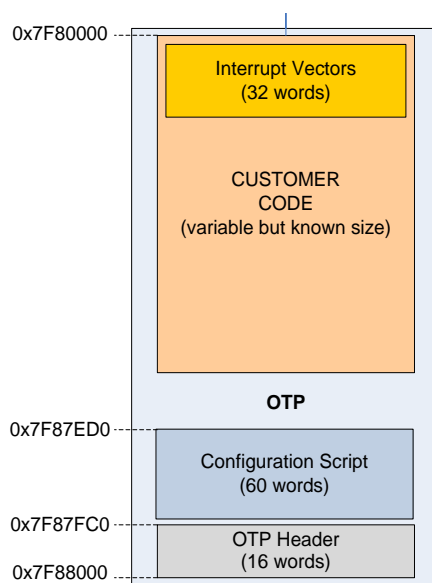

**Figure 10: OTP Layout Scheme**

The OTP memory is a matrix of 8Kx32-bit words. The contents are described below:

- **Interrupt Vectors:** they are the vectors of the interrupt service routines and always reside at the address 0x0. This is part of the application (customer) code. The size of this vector list is 32 words
- **Customer Code:** it contains the applications and the profiles that a customer has developed. The size is known and fixed before the mass production and the programming of the OTP
- **Configuration Script (section 4.4.2):** it is used to program registers with values that are defined during production testing, to store a trim value for the application software, and to define the UART time-out timer during booting. It is executed by the Booter to prepare and initialize the system prior to that the CPU starts running the application code. Available size is 60 words
- **OTP Header:** it contains various information about the configuration of the system and the BLE-specific data. Size of the header is 16 words.

#### 4.4.1 OTP Header

The OTP header breakdown is presented in [Table 29](#).

**Table 29: OTP Header**

Address	Words (32-bit)	Description	Programmed during	
			Chip Test	Product Manufacturing
7F87FC0	1	Application Programmed Flag #1 0x1234A5A5 = Application is in OTP		Yes
7F87FC4	1	Application Programmed Flag #2 0xA5A51234 = Application is in OTP		Yes

Address	Words (32-bit)	Description	Programmed during	
			Chip Test	Product Manufacturing
7F87FC8	1	Boot specific configuration: <ul style="list-style-type: none"> <li>● Bits[7:0] :               <ul style="list-style-type: none"> <li>○ 0xAA = Boot from SPI port at a specific location</li> <li>○ 0xFF = Normal sequence</li> </ul> </li> <li>● Bits[15:8] = Wake up Command opcode</li> <li>● Bits[23:16] = SPI_DIV</li> <li>● Bits[31:24]:               <ul style="list-style-type: none"> <li>○ 0x00 = Two-wire UART (P0_0/P0_1)</li> <li>○ 0x01 = One-wire UART (P0_3)</li> <li>○ 0x02 = One-wire UART (P0_5)</li> <li>○ Default (all other values) = Two-wire UART (P0_0/P0_1)</li> </ul> </li> </ul>		Yes
7F87FCC	1	Boot specific port mapping: Bits[7:4] = SPI_CLK, Port number Bits[3:0] = SPI_CLK, Pin number Bits[15:12] = SPI_EN, Port number Bits[11:8] = SPI_EN, Pin number Bits[23:20] = SPI_DO, Port number Bits[19:16] = SPI_DO, Pin number Bits[31:28] = SPI_DI, Port number Bits[27:24] = SPI_DI, Pin number		Yes
7F87FD0	1	Device and Package Flag: <ul style="list-style-type: none"> <li>● Bits[7:0]:               <ul style="list-style-type: none"> <li>○ 0xFF = WLCSP with P0_5</li> <li>○ 0x66 = WLCSP without P0_5</li> <li>○ 0xAA = FCGQFN24</li> </ul> </li> <li>● Bits[15:8]:               <ul style="list-style-type: none"> <li>○ 0xFF = 531</li> <li>○ 0x30 = 530</li> <li>○ Others = Reserved</li> </ul> </li> <li>● Bits[31:16] = Reserved</li> </ul>	Yes	
7F87FD4	2	Bluetooth Device Address (64-bit word). It is handled as a string of bytes.		Yes
7F87FDC	1	OTP DMA length (number of 32-bit words).		Yes
7F87FE0	1	Position: Bits[7:0] = X coord Bits[15:8] = Y coord Bits[23:16] = Wafer # Bits[31:24] = LOT #	Yes	
7F87FE4	1	Tester: Bits[7:0] = Tester_Site Bits[15:8] = Tester_ID (LSB) Bits[23:16] = Tester_ID (MSB) Bits[31:24] = Reserved	Yes	

Address	Words (32-bit)	Description	Programmed during	
			Chip Test	Product Manufacturing
7F87FE8	1	TimeStamp: Bits[7:0] = TS_Byte0 Bits[15:8] = TS_Byte1 Bits[23:16] = TS_Byte2 Bits[31:24] = TS_Byte3	Yes	
7F87FEC	5	Reserved for Future Needs		

The Device and Package Flag reflects what the current device (DA14530) is and which package is used. Default (unprogrammed) values are 0xFFFFFFFF.

Boot specific mapping value is used to define a specific configuration for the SPI interface when used for booting from an external device (either an MCU or a FLASH). Byte0 is the flag to instruct the BootROM to use the specific SPI pin mapping and skip the rest of the serial peripheral interfaces. The BootROM takes care of waking up an external flash when the flash memory is in deep power-down state.

Byte1 is used for the Wake-up Command opcode that the flash memory responds to. If Byte0 is left unprogrammed, the BootROM will send the "0xAB" opcode by default. Furthermore, the BootROM is able to wake up the external flash by toggling the CS pin.

Two more flags indicate whether the application code has indeed been programmed (burned) into the OTP. Both flags are read by the BootROM software designating that the system is in the Normal mode and not in the Development mode (section 4.5).

#### 4.4.2 Configuration Script

The Configuration Script (CS) is a table of 32-bit entries and is 60 words deep, so in total the CS can utilize 240 bytes of space.

The CS is used to program registers with values that are defined during production testing, to store a trim value for the application software, and to define the UART time-out timer during booting. It is executed by the Booter to prepare and initialize the system prior to that the CPU starts running the application code.

The format of the commands in the CS is presented in [Table 30](#).

**Table 30: CS Commands and Description**

#	Command Type	Description
1	Start Command	One 32-bit word containing 0xA5A5A5A5 to signal a valid CS is in place.
2	Register Configuration	<ul style="list-style-type: none"> <li>One 32-bit word containing an address of an existing register</li> <li>One 32-bit word containing the data value of the register</li> </ul> These are always in pairs with the address sitting in even memory addresses.
3	SDK Value	One 32-bit word which is equal to 0x9000YYXX indicating that the next word is a value stored during production testing. More specifically: <ul style="list-style-type: none"> <li>9: it indicates that the following word(s) are not to be stored to registers but will be used by the SDK SW</li> <li>YY: it indicates that YY amount of words follow</li> <li>XX: it is an increasing value and can be used for indexing by the SW application. If YY &gt; 1, XX will not be increased for the words that belong to the same value</li> </ul> One or more 32-bit words can represent one value.
4	SWD mode	One 32-bit word which is equal to 0x70000000. It prevents the JTAG from being enabled at the end of the Booter and the Booter will not enter the endless while (1) loop. Instead it will continue to rescan all peripherals in the development mode path.

#	Command Type	Description
5	UART STX timeout value	One 32-bit word which is equal to 0x8XXXXXXX. The XXXXXXXX is used to program the selected STX timeout in multiples of 100 $\mu$ s. So, for example, 0x80000028 is 40 $\times$ 100 $\mu$ s = 4 ms.
6	SPI Clock value	0xA0000000 This value overwrites the default 2-MHz clock speed of the SPI boot path and sets it to 32 MHz.

The Booter stops processing the CS once it encounters an empty OTP value (0xFFFFFFFF). This way, no more processing time is spent to check the rest and it is possible to add new entries later, for example, to patch/update previous entries.

An example describing the format of the configuration script is presented in [Table 31](#).

**Table 31: CS Example**

Words	Even Words	Odd Words	Description
0-1	0xA5A5A5A5	0x80000028	Start command of the CS Script, followed by STX timeout value of 4 ms (40 $\times$ 100 $\mu$ s)
2-3	<Address>	<Value>	Booter automatically writes the <Value> to the <Address>
4-5	0x90000301	<Value>	Three calibration values stored during production testing. SDK should know what this is for.
6-7	<Value>	<Value>	
8-9	<Address>	<Value>	Booter automatically write the <Value> to the <Address>
10-11	<Address>	<Value>	Booter automatically write the <Value> to <Address>
12-13	0x90000402	<Value1>	Four calibration values stored during production testing. SDK should know what this is for.
14-15	<Value2>	<Value3>	Calibration value stored during production testing. SDK should know what this is for.
16-17	<Value4>	0x70000000	Disable SWD
18-19	0xFFFFFFFF	(don't care)	Booter stops running the CS after an empty entry, so anything after this is "don't care".

## 4.5 BootROM Sequence

The booting process of the DA14530 is presented in [Figure 11](#). The Booter is always executed when a POR or a HW Reset occurs, or the RESET\_ON\_WAKEUP feature is configured.

The booter will start executing with the RC32M clock, to speed up its execution. To access the OTP,  $V_{BAT}$  needs to be set at  $\geq 1.8$  V. After the OTP is operational, the Booter initializes the UART baud rate at 115.2 kHz, and the CS (section 4.4.2) is enabled to be executed.

After the CS has been executed, the Booter has to decide whether the device is in Development or Normal mode by reading the two words indicated as application flags in the OTP. The OTP image is copied into RAM starting at address 0x0 by the Booter.

In Development mode, the "Boot from Specific" flag will be evaluated. If this flag is programmed, new pin locations for booting from an external SPI slave to make DA14530 an SPI Master will be set allowing for booting from a different pin configuration than the default one, so that the system can boot from an external FLASH using the development mode. The details of the configuration are presented in section 4.4.1. If this path is entered, the system will always try to boot from UART so that the SPI Flash can be updated if needed. Any of the three UART configurations specified in [Table 32](#) can be selected by writing bits [31:24] at the "Boot specific config" field in the OTP header. If booting from SPI Flash fails, the Booter will jump back to the normal scan sequence of the peripheral devices.

If the "Boot from Specific" flag is not programmed, the system should continue with scanning the different serial interfaces to identify whether a device is connected to it. After OTP is disabled, six steps as described in Table 32 are performed. Before using the UART, the XTAL32M clock is enabled. All boot steps are protected by a timeout.

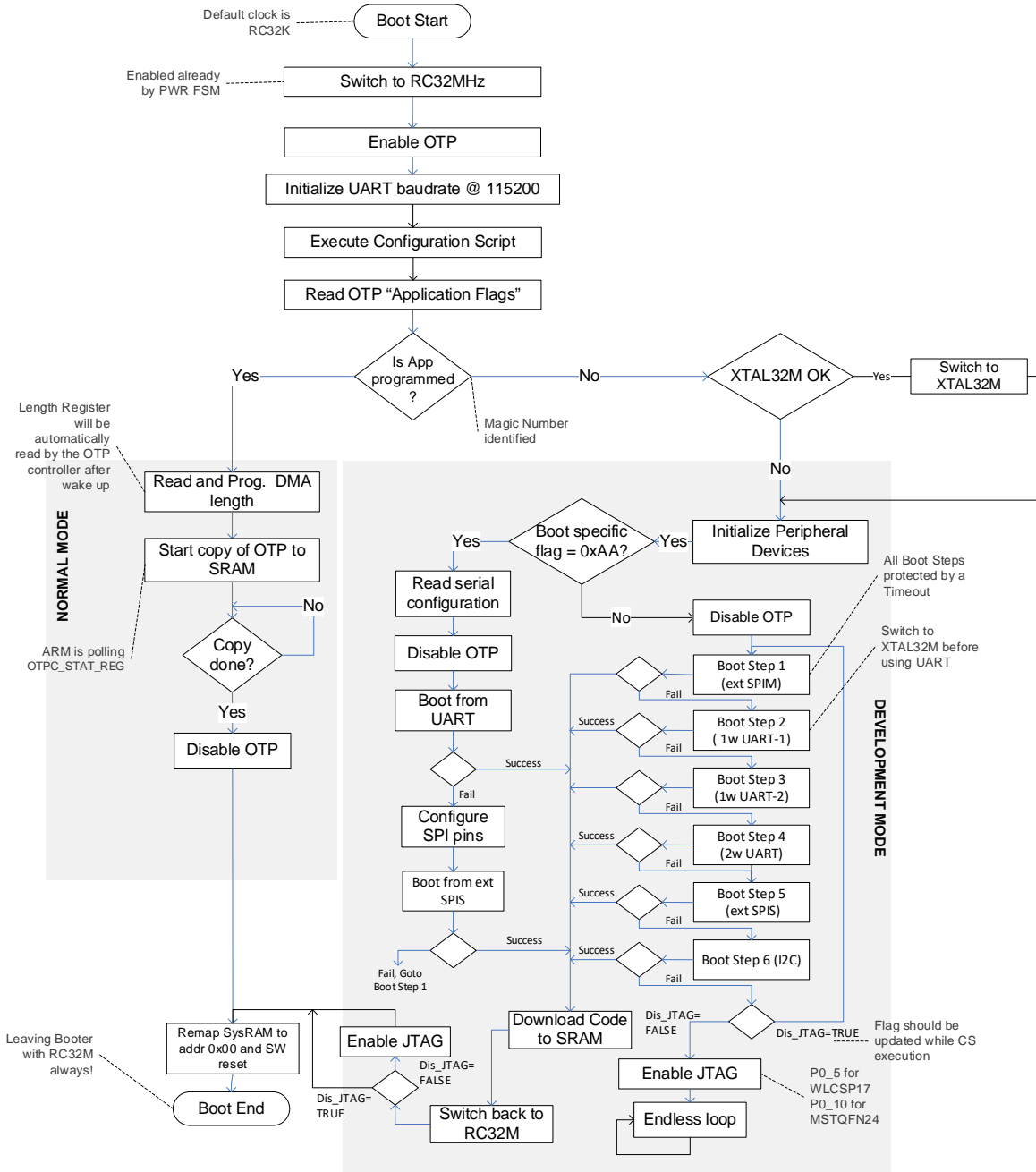

Figure 11: BootROM Sequence

The one-wire UART boot capability the same as for a 2-wire UART booting except that the Booter SW controls the pin direction before sending or receiving information.



Table 32: Booting Sequence Steps

	Step 1: Boot from external SPI Master	Step 2: Boot from 1-wire UART (first option)	Step 3: Boot from 1-wire UART (second option)	Step 4: Boot from 2-wire UART	Step 5: Boot from external SPI Slave	Step 6: Boot from I2C
P0_0/RST	MISO			Tx	MOSI	
P0_1	MOSI			Rx	SCS	
P0_2						
P0_3	SCS		RxTx		MISO	SDA
P0_4	SCK				SCK	SCL
P0_5		RxTx (Default)				
P0_6						
P0_7						
P0_8						
P0_9						
P0_10						
P0_11						

If no bootable devices are found on any of the serial interfaces, the Booter can do two things, depending on what is stored in the CS. If the "Debugger disable" (0x70000000) command is stored there, the Booter will start scanning for peripherals again. Otherwise it enters the endless loop with the debugger (JTAG) being enabled. The debugger can be connected to P0\_10/P0\_02 for data (SWDIO) and clock (SDCLK) respectively.

After the BootROM sequence has completed, the default system clock is RC32M, regardless of which boot path has been chosen and all GPIOs are set back to their default reset values.

## 5 Reset

### 5.1 Introduction

The DA14530 comprises a reset (RST) pad which is active high. It contains an RC filter with a resistor of 465 k $\Omega$  and a capacitor of 3.5 pF to suppress spikes. It also contains a 25 k $\Omega$  pull-down resistor. This pad should be driven externally by a field-effect transistor (FET) or a single button connected to VBAT. The typical latency of the RST pad is in the range of 2  $\mu$ s.

#### Features

- RC spike filter on RST to suppress external spikes (465 k $\Omega$ , 3.5 pF)
- Three different reset lines (SW, HW, and POR)
- Latching the cause of a reset operation (RESET\_STAT\_REG)
- Configurable POR circuitry

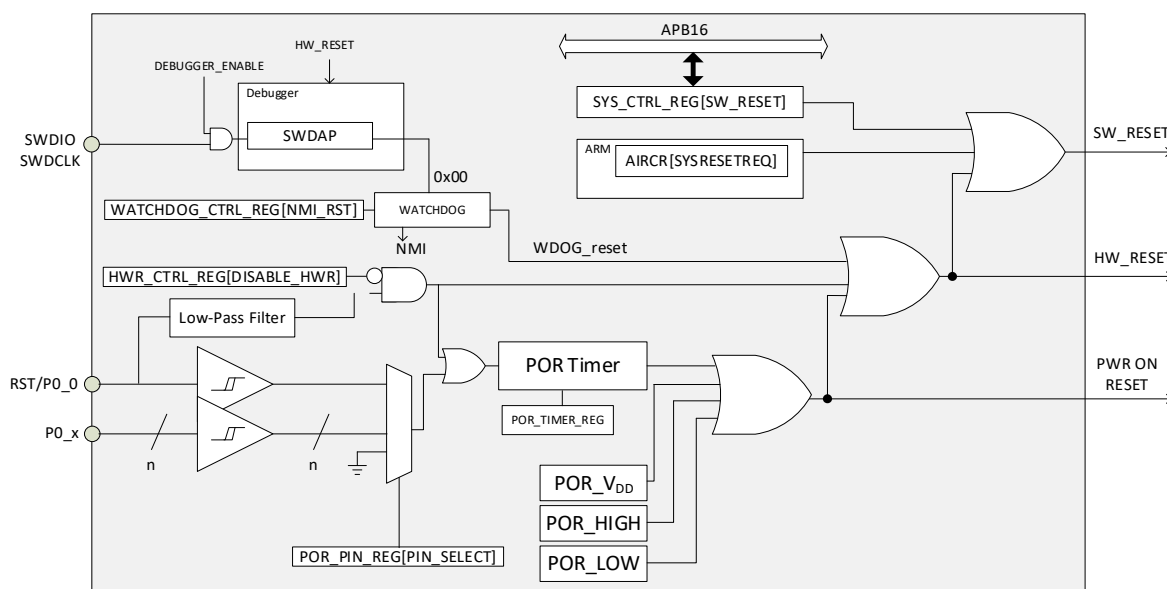

Figure 12: Reset Block Diagram

### 5.2 Architecture

#### 5.2.1 POR, HW, and SW Reset

There are three main reset signals in the DA14530:

- The Power-On Reset (POR): it is optional triggered by a GPIO set as the POR source with a selectable polarity and/or the RST pad (P0\_0) after a programmable time delay
- The HW reset: it is optional triggered by the RST pad (P0\_0) when it becomes active for a short period of time (less than the programmable delay for POR)
- The SW reset: it is triggered by writing the SYS\_CTRL\_REG[SW\_RESET] bit

The POR signal is generated:

- Internally and will release the system's flip flops as soon as the VDD, V<sub>BAT\_HIGH</sub>, and V<sub>BAT\_LOW</sub> voltages crossed the specified thresholds
- Externally by a POR source (RST pad multiplexed on a GPIO or P0\_0 configured as RST pin)

The HW reset can also be automatically activated when the system wakes up from the Extended or Deep Sleep mode by programming the bit PMU\_CTRL\_REG[RESET\_ON\_WAKEUP]. The POR and the HW reset basically run the cold start-up sequence and the BootROM code is executed.

The SW reset is the logical OR of a signal from the Cortex CPU (triggered by writing SCB->AIRCR = 0x05FA0004) and the SYS\_CTRL\_REG[SW\_RESET] bit. It is mainly used to reboot the system after the base address has been remapped.

The block diagram of the reset block is depicted in [Figure 12](#).

Certain registers are reset by POR only, or by POR and the HW reset signal but not by the SW reset. These registers are listed in [Table 33](#).

**Table 33: Reset Signals and Registers**

Reset by POR Only	Reset by POR or HW Reset	Reset by POR, HW Reset, or SW Reset
BANDGAP_REG	BLE_CNTL2_REG	The rest of the Register File
POR_PIN_REG	CLK_AMBA_REG[OTP_ENABLE]	
POR_TIMER_REG	CLK_FREQ_TRIM_REG	
HWR_CTRL_REG	CLK_RADIO_REG	
RESET_STAT_REG[PORESET_STAT]	CLK_CTRL_REG	
PAD_LATCH_REG	PMU_CTRL_REG	
POWER_AON_CTARL_REG	SYS_CTRL_REG	
GP_DATA_REG	TRIM_CTRL_REG	
TEST_VDD_REG	RAM_PWR_CTRL_REG	
	CLK_RC32K_REG	
	CLK_XTAL32K_REG	
	CLK_RC32M_REG	
	CLK_RCX_REG	
	XTALRDY_CTRL_REG	
	XTAL32M_CTRL0_REG	
	PMU_SLEEP_REG	
	POWER_CTRL_REG	
	POWER_LEVEL_REG	
	RAM_LPMX_REG	
	HIBERN_CTRL_REG	
	CLK_RTCDIV_REG	
	RTC_CONTROL_REG	
	RTC_KEEP_RTC_REG	
	OTPC_*_REG	
	QDEC_*_REG	
	All RF calibration registers	

### 5.2.2 POR Functionality

The POR functionality is available by two sources:

- RST Pad: the RST pad is always capable of producing a POR

- GPIO Pin: a GPIO can be selected by the user application to act as a POR source

The time needed for a GPIO pin selected for the POR to be active is stored in the POR\_TIMER\_REG. The register field POR\_TIME is a 7-bit field which holds the time factor by which the total time for POR is calculated. The maximum value of the field is 0x7F. The total time for POR is calculated by the following formula:

$$\text{Total time} = \text{POR\_TIME} \times 4096 \times \text{RC32k clock period} \quad (1)$$

where RC32k clock period = 31.25 μs at 25°C.

The maximum time for which a POR can be performed is ~16.2 seconds at 25°C.

The RC32k clock frequency depends on temperature, so based on the temperature span of -10°C to 50°C, the clock frequency range is calculated to be 25 kHz to 39 kHz. Then,

$$T_{\text{PORcold}} = 13 \text{ s}$$

$$T_{\text{PORhot}} = 20.8 \text{ s}$$

#### 5.2.2.1 POR Timer Clock

The POR timer is clocked by the RC32k clock. If a SW application disables the RC32k, the HW takes care of enabling the RC32k clock when a POR source (the RST pad or a selected GPIO pin) is asserted. It should be noted that if the POR is generated from the RST pad, the RC32k will operate with the reset (default) trimming value. If a GPIO pin is used as the POR source, the RC32k clock will be trimmed. The timing difference between both cases is expected to be minor.

#### 5.2.2.2 RST Pad

The RST pad will produce a HW reset if the pin active time is less than the programmed value in the POR\_TIMER\_REG register or a POR if the pin active time is greater than or equal to that value. Reset pad is always Active High.

#### 5.2.2.3 POR from GPIO

When a GPIO is used as a POR source, the selected pin retains its capability to act as GPIO. The POR\_PIN\_REG[PIN\_SELECT] field holds the required GPIO pin number. If the value of the PIN\_SELECT field equals to 0, the POR triggered by GPIO functionality is disabled. The polarity of the pin can be configured by the POR\_PIN\_REG [POR\_POLARITY] bit, where 0 means Active Low and 1 means Active High.

### 5.2.3 POR Timing Diagram

The operation of the POR triggered by both the RST pad and a selected GPIO pin is depicted in Figure 13.

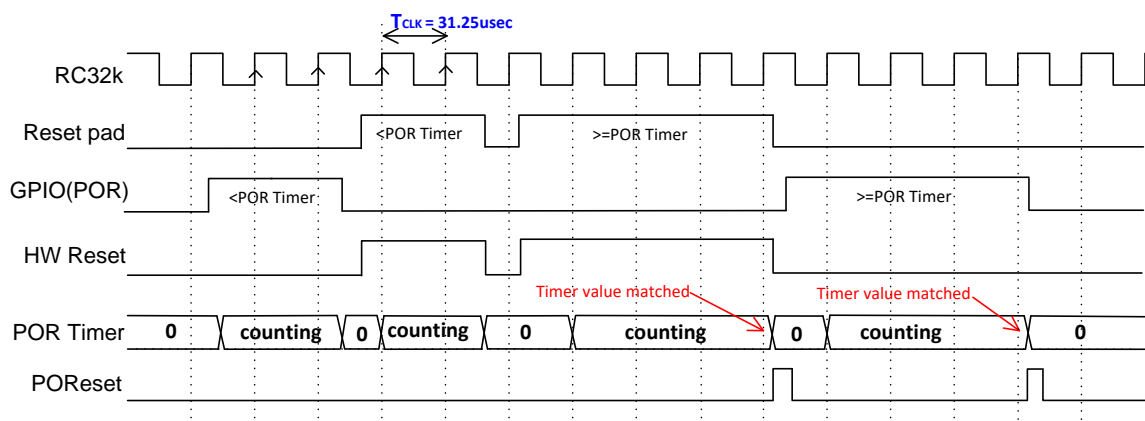

Figure 13: POR Timing Diagram

### 5.2.4 POR Considerations

When a POR source (the RST pad or a selected GPIO pin) is asserted, the POR timer starts to count. When the POR source is released before the timer has expired, the POR timer will be reset to 0. If a POR source is asserted while there is already an asserted POR, and the first POR is released after the second POR is asserted, and the total time of the two asserted sources is larger than or equal to the POR\_TIME, POR will occur.

It should also be noted that the POR timer triggered by the RST pad can only expire once. After the POR timer has expired, the RST pad has to be released so the timer can be reloaded. There is no such limitation when a GPIO is used as the POR source.

The POR\_PIN\_REG[PIN\_SELECT] field cannot survive any reset (POR, HW reset, or SW reset), therefore, users must take special care on setting up the GPIO POR source right after a reset. This also applies to the POR\_TIMER\_REG[POR\_TIME] field after a POR.

Please be aware of that, if a GPIO is used as a POR source, the dynamic current of the system increases due to the dynamic current consumed by the RC32k oscillator. This increase is calculated to be from 100 nA to 120 nA and it is also present during sleep time period. POR from the RST pad does not add this dynamic current consumption.

## 5.3 Programming

To configure the functionality of triggering a POR by a GPIO pin, follow the steps below:

1. Select a GPIO to be set as the POR source by programming POR\_PIN\_REG[POR\_PIN\_SELECT].
2. Set up the input polarity of the GPIO that causes POR by programming POR\_PIN\_REG[POR\_PIN\_POLARITY].
3. Configure the time for the POR to happen by programming POR\_TIMER\_REG[POR\_TIME]. The default time is around three seconds.

NOTE
To set up the time when the RST pad produces a POR, just set the POR_TIMER_REG register.

## 6 Arm Cortex-M0+

### 6.1 Introduction

The Arm Cortex-M0+ processor is a 32-bit Reduced Instruction Set Computing (RISC) processor with a von Neumann architecture (single bus interface). It uses an instruction set called Thumb, which was first supported in the ARM7TDMI processor, but it also uses several newer instructions from the Armv6 architecture and a few instructions from the Thumb-2 technology. Thumb-2 technology extends the previous Thumb instruction set to allow all operations to be carried out in one CPU state. The instruction set in Thumb-2 includes both 16-bit and 32-bit instructions; most instructions generated by the C compiler use the 16-bit instructions, and the 32-bit instructions are used when the 16-bit version cannot carry out the required operations. This results in high code density and avoids the overhead of switching between two instruction sets.

In total, the Cortex-M0+ processor supports only 56 base instructions, although some instructions can have more than one form. Although the instruction set is small, the Cortex-M0+ processor is highly capable because the Thumb instruction set is highly optimized.

Academically, the Cortex-M0+ processor is classified as load-store architecture, as it has separate instructions for reading and writing to memory, and instructions for arithmetic or logical operations that use registers. It has a two-stage pipeline (fetch+predecode and decode+execute) as opposed to its predecessor (Cortex-M0) that has a three-stage pipeline (fetch, decode, and execute).

A simplified block diagram of the Cortex-M0+ is shown in [Figure 14](#).

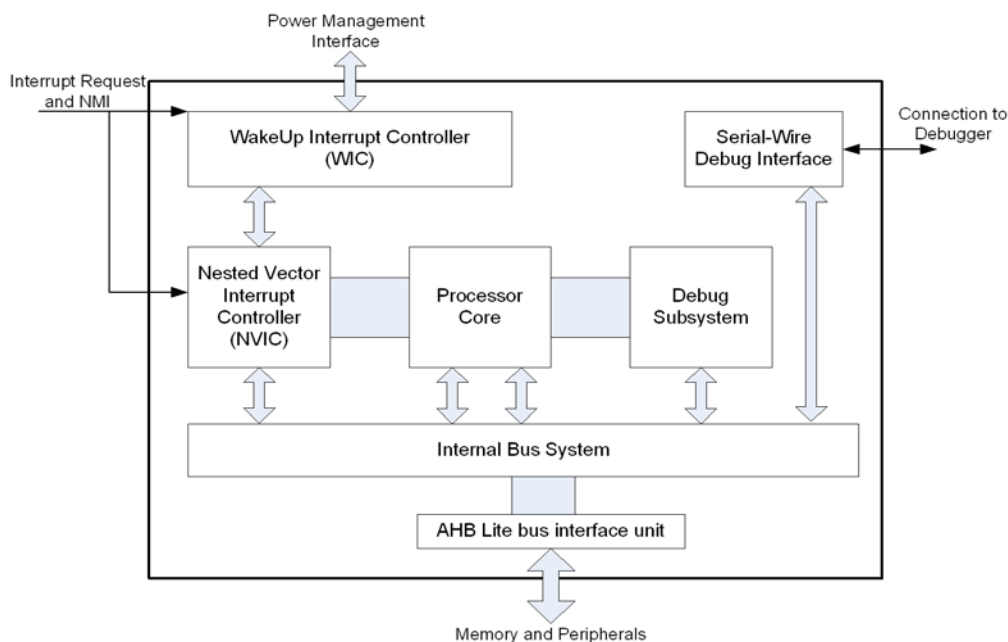

**Figure 14: Arm Cortex-M0+ Block Diagram**

#### Features

- Thumb instruction set: highly efficient, of high code density, and able to execute all Thumb and Thumb-2 instructions
- High performance: up to 0.9 DMIPS/MHz (Dhrystone 2.1) with fast multiplier
- Built-in Nested Vectored Interrupt Controller (NVIC): this makes interrupt configuration and coding of exception handlers easy. When an interrupt request is taken, the corresponding interrupt handler is executed automatically without the need to determine the exception vector in software
- Interrupts can have four different programmable priority levels and the NVIC automatically handles nested interrupts

- The design is configured to respond to exceptions (for example, interrupts) as soon as possible (minimum 15 clock cycles)
- Non maskable interrupt (NMI) input for safety critical systems
- Easy to use and C friendly. There are only two modes, Thread mode and Handler mode. The whole application, including exception handlers, can be written in C without any assemblers
- Built-in System Tick timer for OS support. A 24-bit timer with a dedicated exception type is included in the architecture, which the OS can use as a tick timer or as a general timer in other applications without an OS
- SuperVisor Call (SVC) instruction with a dedicated SVC exception and Pendable SuperVisor service (PendSV) to support various operations in an embedded OS
- Architecturally defined sleep modes and instructions to enter sleep. The sleep features allow power consumption to be reduced dramatically. Defining sleep modes as an architectural feature makes porting of software easier because the sleep modes are entered by specific instructions rather than implementation defined control registers
- Fault handling exception to catch various sources of errors in the system
- Support for 21 interrupts
- Little endian memory support
- Wake-up Interrupt Controller (WIC) to allow the processor to be powered down during sleep, while interrupt sources are still allowed to wake up the system
- Halt mode debug allows the processor activity to stop completely so that register values can be accessed and modified. No overhead in code size and stack memory size
- CoreSight technology allows memories and peripherals to be accessed from the debugger without halting the processor
- Supports Serial Wire Debug (SWD) connections. The SWD protocol can handle the same debug features as the JTAG, but it only requires two wires and is already supported by a number of debug solutions from various tools vendors
- Four (4) hardware breakpoints and two (2) watch points
- Breakpoint instruction support for an unlimited number of software breakpoints
- Programmer's model similar to the ARM7TDMI processor. Most existing Thumb code for the ARM7TDMI processor can be reused. This also makes it easy for ARM7TDMI users, as there is no need to learn a new instruction set.

## 6.2 Architecture

### 6.2.1 Interrupts

This section lists all 21 interrupt lines, except the NMI interrupt, and describes their sources and functionality. The overview of the interrupts is illustrated in [Table 34](#).

**Table 34: Interrupt List**

IRQ Number (Inherent Priority)	IRQ Name	Description
0	BLE_WAKEUP_LP_IRQn	Wake up the system from Low Power (Extended Sleep) interrupt from BLE.
1	BLE_GEN_IRQn	BLE Interrupt. Sources: <ul style="list-style-type: none"> <li>• BLE_FINETGTIM_IRQn: Fine Target Timer interrupt generated when Fine Target timer expires. The timer resolution is 625 <math>\mu</math>s base time reference</li> </ul>

IRQ Number (Inherent Priority)	IRQ Name	Description
		<ul style="list-style-type: none"> <li>• BLE_GROSSTGTIM_IRQn: Gross Target Timer interrupt generated when Gross Target timer expired. The timer resolution is 16 times 625 <math>\mu</math>s base time reference</li> <li>• BLE_CSCNT_IRQn: 625 <math>\mu</math>s base time reference interrupt, available in active modes</li> <li>• BLE_SLP_IRQn: End of Sleep mode interrupt</li> <li>• BLE_ERROR_IRQn: Error interrupt, generated when undesired behavior or bad programming occurs in the BLE Core</li> <li>• BLE_RX_IRQn: Receipt interrupt at the end of each received packets</li> <li>• BLE_EVENT_IRQn: End of Advertising/Scanning/Connection events interrupt</li> <li>• BLE_CRYPT_IRQn: Encryption/Decryption interrupt, generated when AES and/or CCM processing is finished</li> <li>• BLE_SW_IRQn: SW triggered interrupt, generated on SW request</li> </ul>
2	UART_IRQn	UART interrupt.
3	UART2_IRQn	UART2 interrupt.
4	I2C_IRQn	I2C interrupt.
5	SPI_IRQn	SPI interrupt.
6	ADC_IRQn	Analog-Digital Converter interrupt.
7	KEYBRD_IRQn	Keyboard interrupt.
8	BLE_RF_DIAG_IRQn	Baseband or Radio Diagnostics Interrupt. Triggered by internal events of the Radio or Baseband selected by the BLE_RF_DIAGIRQ_REG. For Debug purposes only.
9	RF_CAL_IRQn	RF Calibration Interrupt.
10	GPIO0_IRQn	GPIO interrupt through debounce.
11	GPIO1_IRQn	GPIO interrupt through debounce.
12	GPIO2_IRQn	GPIO interrupt through debounce.
13	GPIO3_IRQn	GPIO interrupt through debounce.
14	GPIO4_IRQn	GPIO interrupt through debounce.
15	SWTIM_IRQn	Timer0/2 interrupt.
16	WKUP_QUADEC_IRQn	Combines the Wake-up Capture Timer interrupt, the GPIO interrupt, and the QuadDecoder interrupt.
17	TIM1_IRQn	Timer1 interrupt.
18	RTC_IRQn	Real Time Clock interrupt.
19	DMA_IRQn	DMA interrupt.
20	XTAL32RDY_IRQn	XTAL32M settling ready interrupt.

Interrupt priorities are programmable by the Arm Cortex-M0+. The lower the priority number, the higher the priority level. The priority level is stored in a byte-wide register, which is set to 0x0 at reset. Interrupts with the same priority level follow a fixed priority order using the interrupt number listed in [Table 34](#) (a lower interrupt number has a higher priority level).



To access the Cortex-M0+ NVIC registers, the Cortex Microcontroller Software Interface Standard (CMSIS) functions can be used. The input parameter IRQn of the CMSIS NVIC access functions is the IRQ number. This can be the IRQ number or (more conveniently) the corresponding IRQ name listed in [Table 34](#). For example, the corresponding interrupt handler name in the vector table for IRQ#15 is SPI\_Handler. For more information on the Arm Cortex-M0+ interrupts and the corresponding CMSIS functions, see *section 4.2 Nested Vectored Interrupt Controller* in the *Cortex-M0+ Devices Generic User Guide*.

The Watchdog interrupt is connected to the NMI input of the processor.

### 6.2.2 System Timer (systick)

The Cortex-M0+ System Timer (SysTick) can be configured for using two different clocks. The SysTick Control & Status (STCSR) register specifies which clock should be used by the counter.

- STCSR[CLKSOURCE] = 0: use the (fixed) external reference clock STCLKEN of 1 MHz
- STCSR[CLKSOURCE] = 1: use the (HCLK\_DIV dependent) processor clock SCLK (for example, 2, 4, 8, or 16 MHz)

The default SysTick Timer configuration uses the (fixed) external reference clock STCLKEN (STCSR[CLKSOURCE] = 0). When necessary, higher clock frequencies can be used with STCSR[CLKSOURCE] = 1, but the software should take the HCLK\_DIV dependent core clock SCLK into account about the timing.

### 6.2.3 Wake-Up Interrupt Controller

The Wake-up Interrupt Controller (WIC) is a peripheral that can detect an interrupt and wake the processor from Extended Sleep mode. The WIC is enabled only when the SLEEPDEEP bit in the system control register is set to 1 (see *System Control Register* in the *Cortex-M0+ Technical Reference Manual*).

The WIC is not programmable and does not have any registers or user interface. It operates entirely from hardware signals. When the WIC is enabled and the processor enters Extended Sleep mode, the power management unit in the system can power down most of the Cortex-M0+ processor. This has the side effect of stopping the SysTick timer. When the WIC receives an interrupt, it takes a number of clock cycles to wake up the processor and restore its state before it can process the interrupt. This means the interrupt latency is increased in Extended Sleep mode.

## 6.3 Programming

For more information on the Arm Cortex-M0+, see the documents listed in [Table 35](#).

**Table 35: Arm Documents List**

	Document Title	Arm Document Number
1	Cortex-M0+ Devices Generic User Guide	Arm DUI 0662B (available on the website)
2	Cortex-M0+ Technical Reference Manual, r0p1	Arm DDI 0484C (available on the website)
3	Armv6-M Architecture Reference Manual	Arm DDI 0419C (can be downloaded by registered customers)

## 7 AMBA Bus

### 7.1 Introduction

The DA14530 is based on the AMBA 2.0 AHB and APB components. The AHB is an AMBA Lite version which requires a single master on the system, but there is arbitration between the Arm Cortex-M0+ CPU and the Direct Memory Access (DMA) engine. There are two APB bridges, one for APB16 and the other for APB32, implementing three different decoded slaves which are grouped according to the power domain structure of the chip.

The AMBA bus organization is presented in Figure 15.

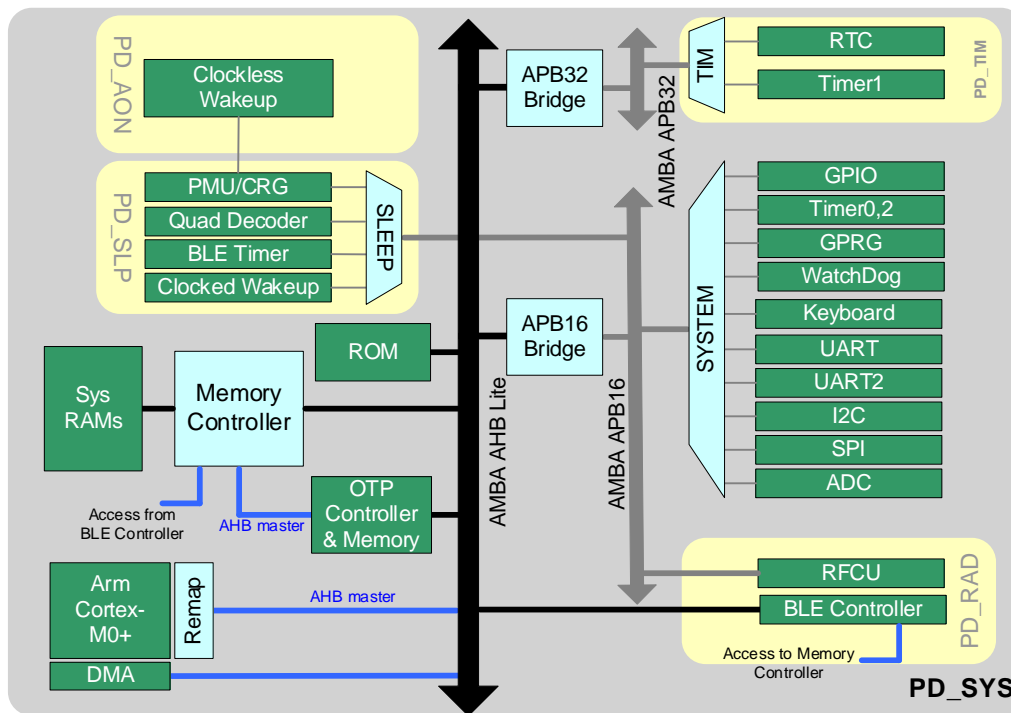

Figure 15: AMBA Bus Architecture and Power Domains

### 7.2 Architecture

Since the DA14530 consists of several different power domains that are digitally controlled and can be shut down completely, various slave resources, especially on the APB bus, are grouped together to reduce signal isolation requirements. On the AHB Lite bus, the CPU or the DMA can be the master, while OTP, BLE Core, Memory and ROM controllers are slaves.

The Always On power domain (PD\_AON) contains only the clock-less wake-up controller and the start-up hardware FSM responsible for the activation of the power devices within the system.

The sleep power domain (PD\_SLP) contains the clock tree, the BLE Timer, the Clocked Wake-up Controller, and the Quadrature Decoder. These blocks are supposed to trigger or to capture wake-up events while the system is in any of the clocked sleep modes.

The timers power domain (PD\_TIM) contains special purpose timers that might or might not be crucial for an application: a full featured Real Time Clock (RTC) engine and Timer1. The registers of these blocks are 32-bit wide, hence they are connected to the APB32 bus.

The APB16 bus connects to the radio power domain (PD\_RAD), which consists of the Radio control unit and the BLE controller, and to the peripheral blocks which are all part of the same power domain as the CPU (PD\_SYS).

### 7.3 Programming

Since the AMBA Bus only acknowledges a single master at a time, a programmable arbitration is implemented to decide whether the Arm Cortex-M0+ or the DMA is the master. The priority can be configured in the GP\_CONTROL\_REG[CPU\_DMA\_BUS\_PRIO] with the CPU having the highest priority by default.

## 8 Memory Map

**Table 36: Memory Map**

Address	Description	Power Domain
0x00000000 0x04000000	<b>Boot/BLE ROM/OTP/RAM</b> Remapped address space based on SYS_CTRL_REG[REMAP_ADR0].	
0x04000000 0x07F00000	<b>RESERVED</b>	
0x07F00000 0x07F24000	<b>Boot/BLE ROM</b> Contains Boot ROM code and BLE protocol related code.	
0x07F24000 0x07F40000	<b>RESERVED</b>	
0x07F40000 0x07F40100	<b>OTP-Regs</b> Contains the control registers of the OTP Subsystem.	PD_SYS
0x07F40100 0x07F80000	<b>RESERVED</b>	
0x07F80000 0x07F88000	<b>OTP</b> Contains the OTP cell actual memory space.	
0x07F88000 0x07F C0000	<b>RESERVED</b>	
0x07FC0000 0x07FCC000	<b>System RAM</b> 48 kB. Contains application code, data for the application, stack, and heap. SysRAM1 (16 kB): 0x07FC0000 to 0x07FC3FFF SysRAM2 (12 kB): 0x07FC4000 to 0x07FC6FFF SysRAM3 (20 kB): 0x07FC7000 to 0x07FCBFFF	
0x07FD8000 0x40000000	<b>RESERVED</b>	
0x40000000 0x40001000	<b>AHB/BLE-Regs</b> Contains the control registers of the BLE Link Layer Processor.	PD_RAD
0x40001000 0x40004000	<b>AHB/Radio</b>	PD_RAD
0x40004000 0x50000000	<b>RESERVED</b>	
0x50000000 0x50000100	<b>APB16/PMU-CRG</b> Contains the control registers of the Power Management Unit and the Clock Generator.	PD_SLP
0x50000100 0x50000200	<b>APB16/wake-up</b> Contains the registers of the clocked and clock-less wake up controllers.	PD_SLP
0x50000200 0x50000300	<b>APB16/Quadrature Decoder</b> Contains Logic that implements a step counter for X and Y axis from a rotary encoder.	PD_SLP
0x50000300 0x50001000	<b>RESERVED</b>	

Address	Description	Power Domain
0x50001000 0x50001100	<b>APB16/UART</b> Contains the control registers of the UART.	PD_SYS
0x50001100 0x50001200	<b>APB16/UART2</b> Contains the control registers of the UART2.	PD_SYS
0x50001200 0x50001300	<b>APB16/SPI</b> Contains the control registers of the SPI interface.	PD_SYS
0x50001300 0x50001400	<b>APB16/I2C</b> Contains the control registers of the I2C interface.	PD_SYS
0x50001400 0x50001500	<b>APB16/Kbrd</b> Contains the registers of the Keyboard controller.	PD_SYS
0x50001500 0x50001600	<b>APB16/ADC</b> Contains the registers of the 4-channel ADC.	PD_SYS
0x50001600 0x50001700	<b>APB16/AnaMisc</b> Contains registers for various analog blocks.	PD_SYS
0x50001700 0x50003000	<b>RESERVED</b>	
0x50003000 0x50003100	<b>APB16/Ports</b> Contains the mode and direction registers of the GPIOs.	PD_SYS
0x50003100 0x50003200	<b>APB16/Watchdog</b> Contains the control registers of the Watchdog timer.	PD_SYS
0x50003200 0x50003300	<b>APB16/Version</b> Contains the version/revision of the chip.	PD_SYS
0x50003300 0x50003400	<b>APB16/Gen Purpose</b> Contains general purpose control registers.	PD_SYS
0x50003400 0x50003500	<b>APB16/Timer</b> Contains the control registers of Timer0 and Timer2.	PD_SYS
0x50003500 0x50003600	<b>APB16/RF Monitor</b> Contains the control registers of the RFMON.	PD_SYS
0x50003600 0x50003700	<b>APB16/DMA</b> Contains the control registers of the DMA.	PD_SYS
0x50003700 0x50004000	<b>RESERVED</b>	
0x50004000 0x50004100	<b>APB32/Timer1</b> Contains the control registers of Timer1.	PD_TIM
0x50004100 0x50004200	<b>APB32/RTC</b> Contains the control registers of the Real Time Clock.	PD_TIM
0x50004200 0xE0000000	<b>RESERVED</b>	
0xE0000000 0xE0100000	<b>Internal Private Bus</b> Contains various registers of the Arm Cortex-M0+.	PD_SYS

## 9 Memory Controller

### 9.1 Introduction

The Memory Controller of DA14531 is responsible for the interface between the memory cells and the masters of the system that request access. It comprises two arbiters which use a fixed priority level scheme to allow parallelization between the three main masters of the RAM. The memory controller also provides the actual physical sequence of the RAM cells in a continuous memory space to enable the activation of the required amount of SysRAM only in order to save power.

The block diagram is presented in [Figure 16](#).

#### Features

- Three different capacities for the RAM cells with retention capability (12 kB, 16 kB, and 20 kB)
- Arbitration among the AHB masters (CPU or DMAs), OTP, and the BLE core
- Transparently interfaces the AHB busses to memory signaling
- Fixed arbitration algorithm with time sharing

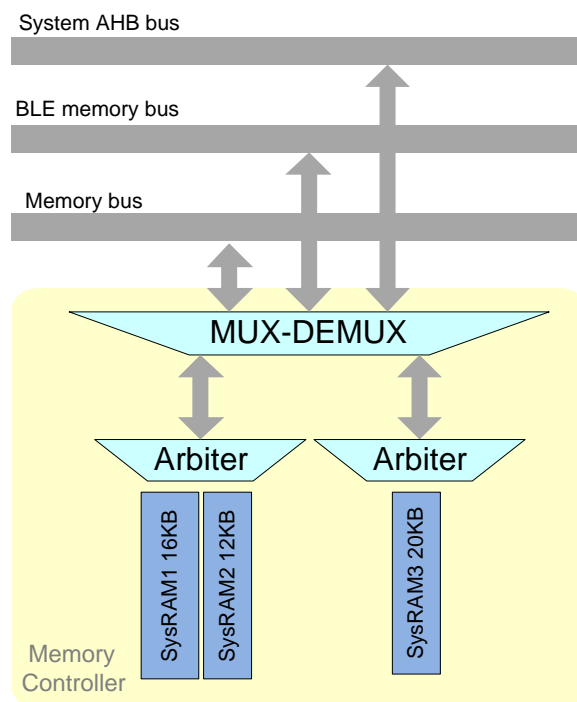

**Figure 16: Memory Controller Block Diagram**

### 9.2 Architecture

The Memory Controller contains two Arbiters which connect to the following busses via a Mux-Demux:

- BLE Mem I/F: this is a memory interface directly from the Bluetooth 5.1 Core to the RAM used as an exchange memory (TX/RX descriptors and others). This interface always operates at 16 MHz
- System Mem I/F: This is a memory interface directly from the OTP memory to the RAM used for copying data after power-up/wake-up

#### 9.2.1 Arbitration

The arbitration is a mixture of the highest priority and a fair use policy. If more than one master request access to cells which reside under the same arbiter, time division is employed. This is to

make sure none of the busses can stall the others for a long period. The OTP and BLE accesses are handled as very critical and therefore they have the highest priority.

## 10 Clock Generation

### 10.1 Clock Tree

The generation of the system's clocks is described in detail in [Figure 17](#).

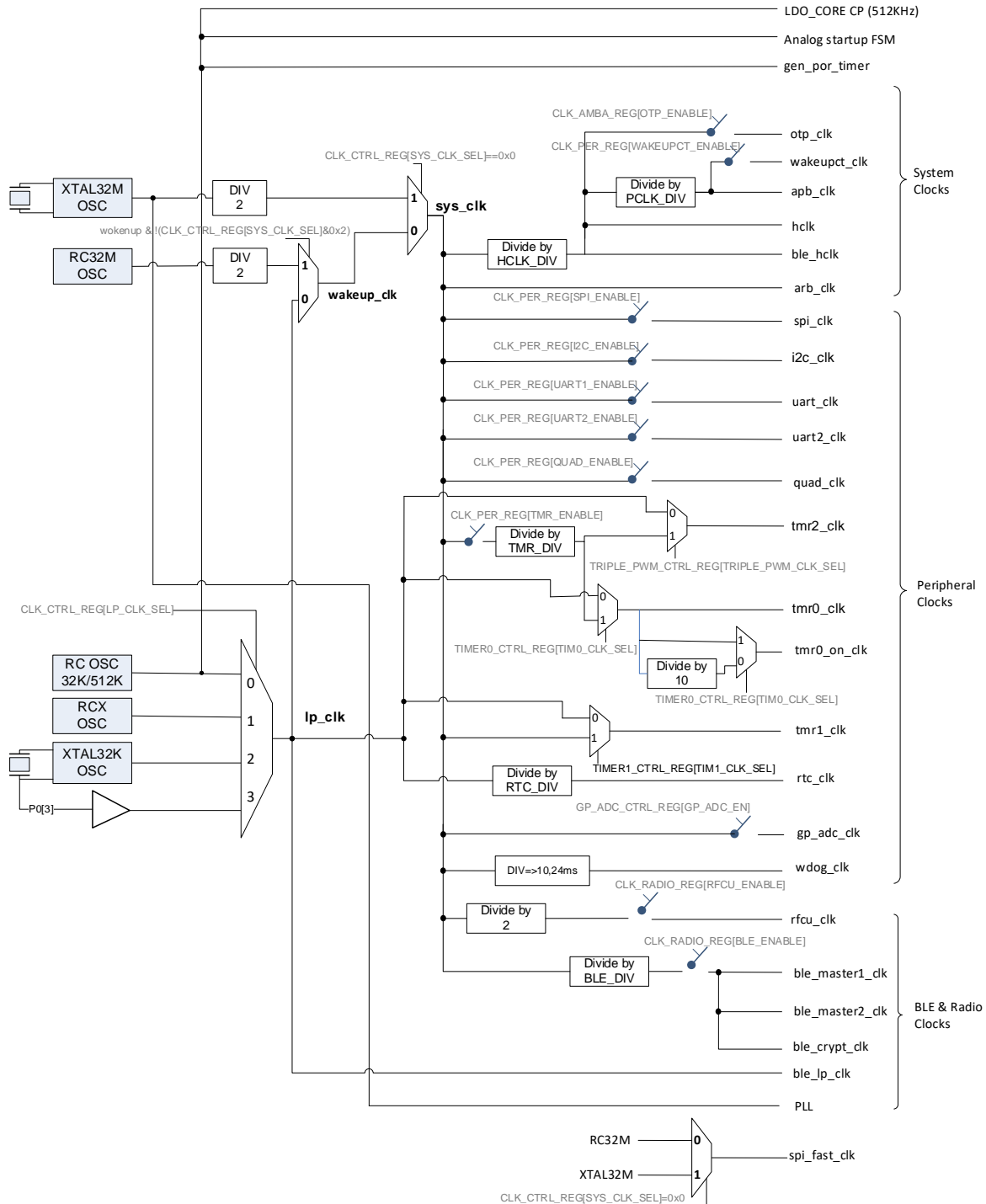

**Figure 17: Clock Tree Diagram**

[Figure 17](#) depicts the possible clock sources as well as all different divisions and multiplexing paths towards the generation of each block's clock. Furthermore, the required registers that have to be programmed are also shown in [Figure 17](#).



Internal clock sources of DA14531 are the RC32M, RC32K/512K, and RCX oscillators. External clock sources of DA14531 are the 32 MHz crystal oscillator (the pins XTAL32Mp and XTAL32Mm), the 32.768 kHz crystal oscillator (the pins XTAL32kp and XTAL32km mapped on P0\_3 and P0\_4, respectively), or an external digital clock (the pin P0\_3).

There are two main clock lines which are of interest:

- **lp\_clk**: this is the low power clock used for the sleep modes and can only be either the RCX, the RC32K, the XTAL32K, or an externally supplied digital clock
- **sys\_clk**: this is the system clock used for the AMBA clock (hclk), which runs the CPU, the memories, and the bus. This clock source can be one of the oscillators or an externally supplied digital clock

The clock names depicted in [Figure 17](#) are explained in [Table 37](#).

**Table 37: Generated Clocks Description**

<b>Clock Name</b>	<b>Description</b>
wakeupct_clk	Clocked wake-up controller clock.
apb_clk	AMBA APB interface clock.
otp_clk	OTP controller clock.
hclk	AMBA AHB interface clock.
ble_hclk	AMBA AHB clock for the BLE core.
wdog_clk	Watchdog clock.
pmu_rc_clk	Clock for the PMU and analog start-up FSM.
icp_clk_512_c (512KHz)	Clock for the Charge pump in the LDO_CORE.
gen_por_timer	Clock for the POR_FORCE Timer.
spi_clk	Clock for the SPI controller. This clock is further divided by 2, 4, 8, or 14 as defined by SPI_CTRL_REG[SPI_CLK].
spi_fast_clk	Fast 32 MHz clock for the SPI controller.
i2c_clk	Clock for the I2C controller. This clock is further divided to provide 100 kHz or 400 kHz as defined by I2C_CON_REG[I2C_SPEED].
uart_clk	Clock for the UART.
uart2_clk	Clock for the UART2.
quad_clk	Clock for the quadrature decoders.
rfcu_clk	Clock for the RF control unit of the Radio.
tmr0_clk, tmr2_clk	Timer0/2 clocks.
tmr1_clk	Timer1 clock.
tmr0_on_clk	Timer0 ON counter clock.
rtc_clk	Clock for Real Time Clock (RTC).
gp_adc_clk	General Purpose ADC conversion clock.
ble_crypt_clk	Clock for the Crypto block of the BLE core.
ble_master1_clk	Internal clock for the BLE core.
ble_master2_clk	Internal clock for the BLE core.
arb_clk	Clock for the memory controller arbiter.
ble_lp_clk	BLE core low power clock.
pll	PLL clock.

#### 10.1.1 General Clock Constraints

There are certain constraints on various clocks regarding their frequency relations or the effectiveness. This section summarizes these rules:

- The minimum of the AMBA clock (hclk) has to be 8 MHz when BLE is utilized. This is also the clock of the Cortex CPU and ensures the required MIPS for handling the BLE Protocol
- The AMBA clock (hclk) should always be greater or equal to the ble\_\*\_clks. This is required for the proper operation of the BLE protocol. For example, hclk at 16 MHz and BLE clocks at 8 MHz is an acceptable combination but not the other way around

#### 10.2 Crystal Oscillators

The Digital Controlled XTAL Oscillators (DXCO) are designed for low power consumption and high stability. There are two such crystal oscillators in the system, one at 32 MHz (XTAL32M) and the other at 32.768 kHz (XTAL32K). The XTAL32K has no trimming capabilities and is used as the clock of the Deep Sleep/Extended Sleep modes. The XTAL32M can be trimmed.

The principle schematic of the two oscillators is shown in Figure 18. No external components to the DA14530 are required other than the crystal itself. If the crystal has a case connection, it is advised to connect the case to ground.

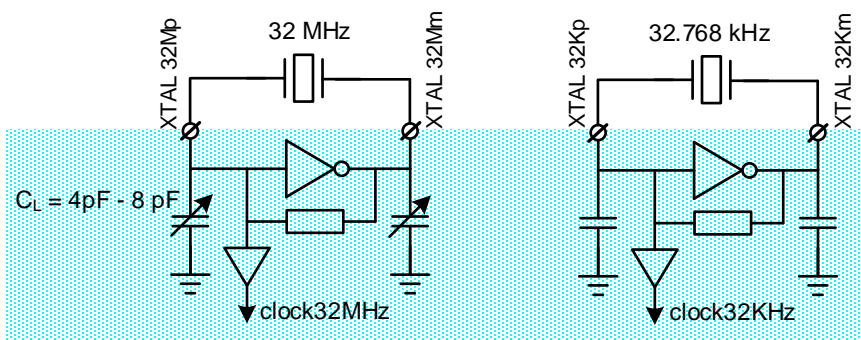

Figure 18: Crystal Oscillator Circuits

##### 10.2.1 Frequency Control (32 MHz Crystal)

The 8-bit register CLK\_FREQ\_TRIM\_REG controls the trimming of the 32 MHz crystal oscillator. The frequency is trimmed by two on-chip variable capacitor banks. Both capacitor banks are controlled by the same register.

The capacitance of both variable capacitor banks varies from the minimum to the maximum value in 256 equal steps. With CLK\_FREQ\_TRIM\_REG[XTAL32M\_TRIM] = 0x00, the minimum capacitance and thus the maximum frequency are selected. With CLK\_FREQ\_TRIM\_REG[XTAL32M\_TRIM] = 0xFF, the maximum capacitance and thus the minimum frequency are selected.

The five least significant bits of CLK\_FREQ\_TRIM\_REG register (XTAL32M\_TRIM<4:0>) directly control five binary weighted capacitors (Figure 19). The three most significant bits of CLK\_FREQ\_TRIM\_REG register (XTAL32M\_TRIM<7:5>) are binary to the thermometer decoded. Each of the seven outputs of the decoder controls a capacitor, of which the value is 32 times the value of the smallest capacitor.

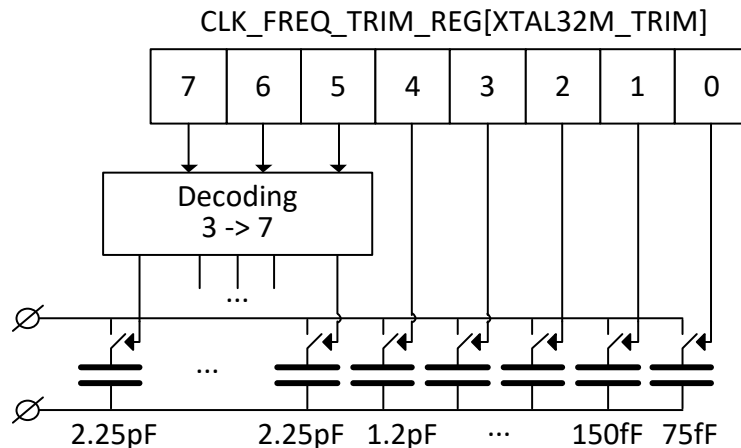

Figure 19: XTAL32MHz Oscillator Frequency Trimming

### 10.2.2 Automated Trimming and Settling Notification

There is provision in the DA14530 for automating the actual trimming of the 32 MHz crystal oscillator. This is a special hardware block that realizes the XTAL trimming in a single step. Notification about the XTAL oscillator being settled after applying the trim value is also provided in form of an interrupt, namely, the XTAL32RDY\_IRQn line. The automated mechanism for applying the trim value and signaling that the oscillator is settled is described in [Figure 20](#).

The XTAL32RDY\_IRQn is always triggered as soon as an internal counter reaches the value programmed at XTALRDY\_CTRL\_REG. This counter runs on the RC32M clock if the system is powering up, or on a selected low power clock if the system is waking up. The enabling of the XTAL32M is always done by HW. There are two sections until the interrupt notifies the software that the XTAL32M can be used:

- The start-up section, where the XTAL32M oscillator is slowly converging towards the initial frequency of the crystal. This section ends with the application of the trim value to achieve a <50 ppm, 32 MHz clock
- The settling section, where the XTAL32M oscillator settles to the preferred frequency after the application of the trim value which is done automatically by HW

There are two ways of deciding when the start-up section ends and when the trim values are supposed to be applied. This decision is controlled by TRIM\_CTRL\_REG[XTAL\_TRIM\_SELECT] bit field:

- **Counter Mode:** trim value stored in the CLK\_FREQ\_REG is applied as soon as an internal counter reaches the value XTAL\_COUNT\_N-1. This is the default mode
- **Current Mode:** trim value is applied as soon as the current drops

The different modes are illustrated in [Figure 20](#).

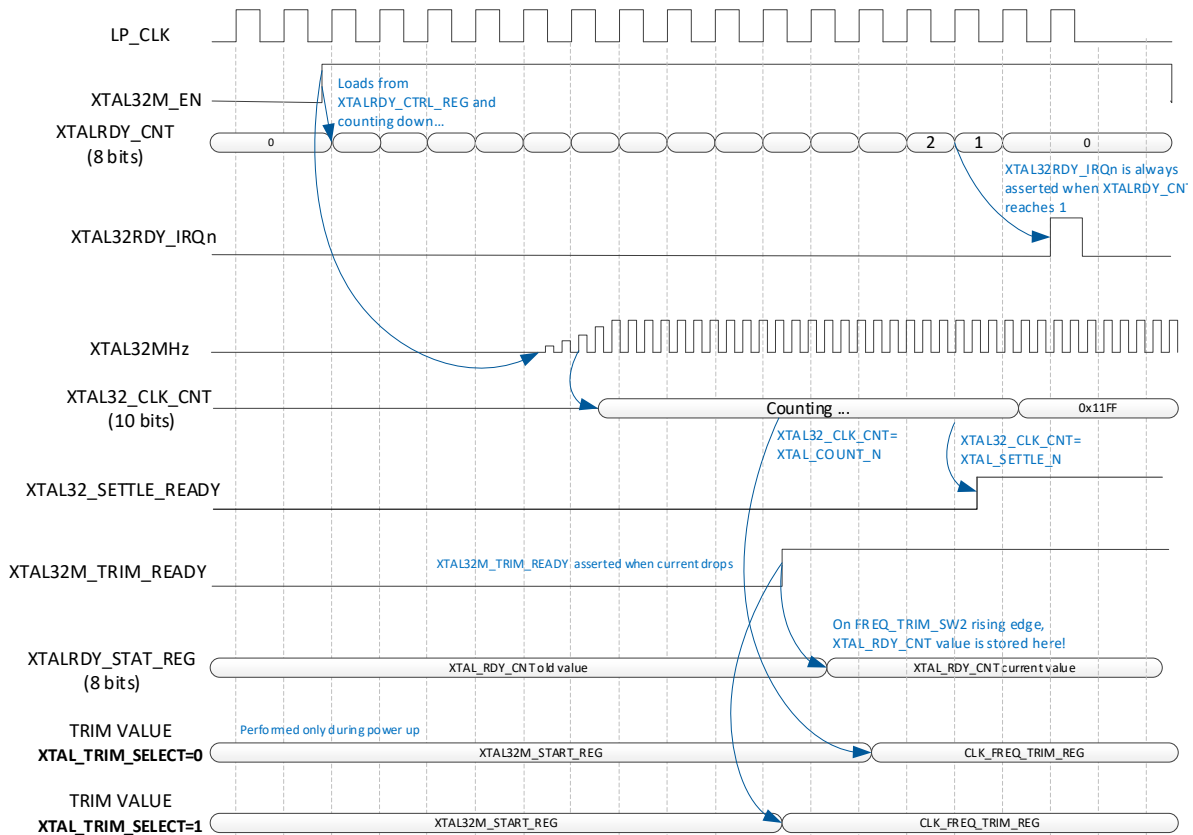

**Figure 20: Automated Mechanism for XTAL32M Trim and Settling**

In both modes mentioned above, trimming is done by HW. In the current mode, upon assertion of XTAL32M\_TRIM\_READY, the interrupt counter value is stored in a shadow register XTALRDY\_STAT\_REG to enable SW understanding when the start-up section is finished.

The settling section usually takes no more than five to 10 clock cycles. Using the explanation above, fine tuning and reducing the XTAL32M latency is feasible. One feature of the XTAL32\_CLK\_CNT is that it asserts an observable signal (SYS\_STAT\_REG[XTAL32\_SETTLE\_READY]) as soon as the counter reaches a pre-defined threshold programmed at TRIM\_CTRL\_REG[XTAL\_SETTLE\_N]. This allows the SW to have an indication of the status of the clock by adjusting the threshold accordingly.

### 10.3 RC Oscillators

There are three RC oscillators in the DA14530:

- One providing 32 MHz (RC32M)
- One providing 32 kHz and 512 kHz (RC32K/512K)
- One providing a frequency of 15 kHz (RCX)

The RC32M is powered by V<sub>BAT\_LOW</sub> which is available during Active or Sleep mode. The output clock is slower than 32 MHz if untrimmed and it is used to clock the CPU and the digital part of the chip during power-up or wake-up, while the XTAL32M oscillator is settling.

The simple RC oscillator (RC32K/512K) operates on V<sub>DD</sub> and provides 32 kHz or 512 kHz. The main usage of the RC32K/512K oscillator is for internal clocking during power-up or start-up. It clocks the HW FSM which brings up the power management system of the chip. In the power-up or start-up sequence, the clock dynamically changes from 32 kHz to 512 kHz in order to speed up the sequence. The enhanced RC oscillator (RCX) provides a stable 15 kHz frequency and operates on V<sub>BAT\_LOW</sub> which is available during Active or Sleep mode.

The RCX oscillator can be used to replace the 32.768 kHz crystal, since it has a precision of < 500 ppm, while its output frequency needs to be recalibrated over temperature.

Using the RCX requires the following registers to be set:

- Set GP\_DATA\_REG = 0x20 after the system wakes up
- RCX calibration (the calibration is optional, please see section 10.3.1 for the RCX calibration)
- Go to sleep: set GP\_DATA\_REG = 0x40 after the sleep procedure is handled

The procedure is also implemented as a part of the SDK.

### 10.3.1 Frequency Calibration

The output frequency of the 32 kHz crystal oscillator and the three RC-oscillators can be measured relative to the 32/2 (16) MHz crystal oscillator using the on-chip reference counter.

The measurement procedure is as follows:

1. REF\_CNT\_VAL = N (the larger number N is, the more accurate and longer the calibration will be)
2. CLK\_REF\_SEL\_REG = 0x0000 (RC32K) or  
CLK\_REF\_SEL\_REG = 0x0001 (RC32M) or  
CLK\_REF\_SEL\_REG = 0x0002 (XTAL32K) or  
CLK\_REF\_SEL\_REG = 0x0003 (RCX)
3. Start the calibration: CLK\_REF\_SEL\_REG[REF\_CAL\_START] = 1
4. Wait until CLK\_REF\_SEL\_REG[REF\_CAL\_START] = 0
5. Read CLK\_REF\_VAL\_H\_REG and CLK\_REF\_VAL\_L\_REG = M (32-bit values)
6. Frequency = (N/M) × 32/2 MHz

If the RCX is used as a sleep clock, the frequency calibration should be implemented on each active time of a connection interval to guarantee a correct operation.

## 11 OTP Controller

### 11.1 Introduction

The OTP controller realizes all functions of the OTP macro cell in an automated and transparent way. The controller facilitates all data transfers (reading and programming), comprises a DMA engine which connects to the AHB bus as a master, and has the highest priority to copy code from OTP into SysRAM in mirrored mode. The block diagram is presented in [Figure 21](#).

#### Features

- Implements all timing constraints for any access to the physical OTP cell
- Automatic single Error Code Correction (ECC) - 6 bits (implemented in the OTP cell)
- 32-bit read in a single read access from the OTP cell
- Single word buffer for programming. No burst programming supported
- Empty words are 0xFFFFFFFF. Zeros are programmed per 32-bit word
- Embedded DMA engine for fast mirroring of the OTP contents into the SysRAM
- Embedded DMA supports reading in bursts of 4 × 32-bit words
- Transparent random address access to the OTP memory cells via the AHB slave memory interface
- Hardwired handshaking with the PMU to realize the mirroring procedure

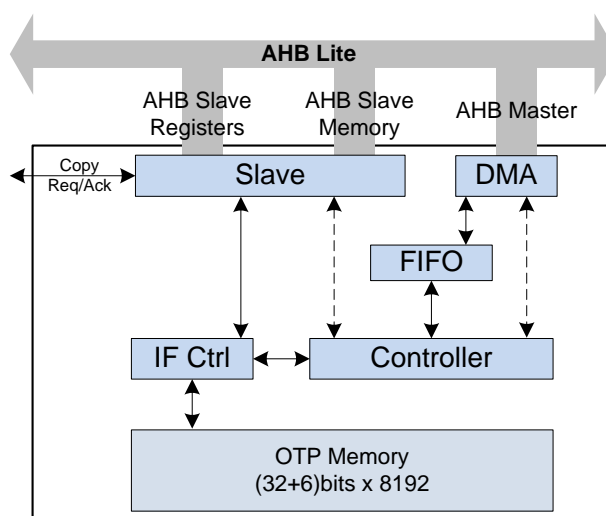

Figure 21: OTP Controller Block Diagram

### 11.2 Architecture

The OTP controller block includes the OTP macro cell and pure digital logic implementing the controlling functions. The OTP memory communicates with the controller through a proprietary interface.

The internal organization of the OTP cell is 32-bit data and 6-bit ECC for each of the 8192 addressable positions. The six bits of the ECC are only accessible within the OTP cell. The ECC is generated by the OTP cell during the programming and is used again by the OTP cell in a transparent way during reading.

The AHB master interface is controlled by a DMA engine with an internal FIFO of eight 32-bit words. The DMA engine supports AHB reads and writes. The AHB address where memory access should begin is programmed into the DMA engine at `OTPC_AHBADR_REG[OTPC_AHBADR]`. The number of the 32-bit words of a transfer minus 1 must be specified in `OTPC_NWORDS_REG[OTP_NWORDS]`.

The DMA engine internally supports the following burst types:

- Eight words incremental burst (INCR8)
- Four words incremental burst (INCR4)
- Unspecified incremental burst (INCR) with a length different from 1, 4, or 8
- Single word access (SINGLE)

The slave block combines two AHB slave interfaces: one is for the registers and can be read from/written to, and the other is for the contents of the OTP memory and is read-only.

The OTP controller configures the OTP cell to be in one of the following modes:

- **Deep Stand-by Mode (DSTBY).** In this mode the required power supplies are applied to the OTP cell, while the internal LDO of the OTP cell is inactive.
- **Stand-by Mode (STBY).** In this mode, the OTP cell is disabled by deactivating the chip select signal. The OTP cell is powered and the internal LDO is enabled. The power consumption of the OTP cell in this mode is not the minimum possible but is less than in an active mode (RD, PROG, PVFY, RINI, AREAD). This is the state from which any active mode of operation can be transitioned into with the least delay.
- **Read Mode (RD).** When this mode is used, the contents of the OTP cell can be read at the respective AHB address space. This mode can also be used to execute software in place (XIP). A read request is translated by the OTP controller into the corresponding control sequence for the OTP cell in order to retrieve the requested data.
- **Programming Mode (PROG).** The PROG mode provides the functionality to program a 32-bit word into an OTP position. The OTP cell expands the 32-bit word by calculating and automatically appending a 6-bit checksum (ECC). Please note that there is no way to access these extra six bits of the ECC information. Programming is performed only for bits equal to 0. Bits equal to 1 are bypassed to save programming time. Because the ECC value is unknown to the controller, there are always six extra programming pulses applied to the ECC bits. Programming is done by issuing a programming request stored in the Programming Buffer (PBUF). PBUF consists of two configuration registers storing the 32-bit data value and the 13-bit address in the OTP cell where the value should be programmed. A new request can only be stored in PBUF when the previous is served. A status bit indicates whether this has already been done, therefore programming should be monitored by SW before a new programming request is issued.
- **Programming Verification Mode (PVFY).** The PVFY mode forces the OTP cell to enter a special margin read mode. This mode is used to verify the content of the OTP positions that have been programmed using the PROG mode and to verify that the programmed data is retrieved correctly under all corner cases. When this mode is used, the contents of the OTP cell can be read at the respective AHB address space. The CPU must read all OTP positions that have been programmed by accessing the corresponding addresses and verify that all the retrieved words are equal to the expected values.
- **Read Initial State Mode (RINI).** The RINI mode implements a production test of the initial margin read, which should be performed in the OTP cell, before the first programming is applied. This test verifies that the OTP cell is empty (all the bits are equal to 1). The OTP controller will send the required control sequence to the OTP cell to enable the test mode. Then the CPU should read all the content of the OTP cell at the respective AHB address space and verify that all the retrieved words are equal to 0xFFFFFFFF. The RINI mode should be used after the PROG mode in order to verify the content of the OTP positions that have been programmed and specify the bits that remain un-programmed. This verification is required to ensure that the programming process has not affected the un-programmed bits. This specific read mode is a margin read, which means that it is not an equivalent to the normal read and should only be used for the purpose of verification.
- **Automatic Read Mode (AREAD).** This mode is used to mirror large parts of the OTP cell into RAM through the AHB master interface and the integrated DMA controller.

Transitioning from one mode to another automatically steps through the STBY mode.



### 11.2.1 OTP Accessing Considerations

Accesses to the OTP memory (read/write) can only be performed at certain voltage ranges. Users are responsible for meeting these conditions while accessing the OTP. The recommended operation conditions of the OTP memory can be found under Recommended Operating Conditions section.

## 11.3 Programming

To configure the OTP controller, following the sequence of steps below:

1. Enable clock for OTP controller by setting the CLK\_AMBA\_REG[OTP\_ENABLE] bit.
2. Put the OTP in STBY mode (OTPC\_MODE\_REG[OTPC\_MODE\_MODE] = 0x1).
3. Wait for OTP mode to change (OTPC\_STAT\_REG[OTPC\_STAT\_MRDY] = 1).
4. Set OTP speed by writing OTPC\_TIM1\_REG and OTPC\_TIM2\_REG if system clock speed is to be reduced. These numbers basically generate asynchronous timing signals towards the OTP cell that comply to the default internal 16 MHz bus speed.
5. Perform an OTP access:
  - a. Programming:
    - i. Set up OTP write mode (OTPC\_MODE\_REG[OTPC\_MODE\_MODE] = 0x3).
    - ii. Wait for OTP mode to change (OTPC\_STAT\_REG[OTPC\_STAT\_MRDY] = 1).
    - iii. Check OTPC\_STAT\_REG[OTPC\_STAT\_PBUF\_EMPTY] = 1
    - iv. Write the data to be programmed to OTPC\_PWORD\_REG.
    - v. Write the address to which the data to be programed to OTPC\_PADDR\_REG.
    - vi. Wait until the programming is finished (OTPC\_STAT\_REG[OTPC\_STAT\_PRDY] = 1).
    - vii. Switch to OTP verify mode (OTPC\_MODE\_REG[OTPC\_MODE\_MODE] = 0x4).
    - viii. Wait for OTP mode to change (OTPC\_STAT\_REG[OTPC\_STAT\_MRDY] = 1).
    - ix. Read back and compare the data written.
    - x. Put the OTP in STBY mode (OTPC\_MODE\_REG[OTPC\_MODE\_MODE] = 0x1).
    - xi. Wait for OTP mode to change (OTPC\_STAT\_REG[OTPC\_STAT\_MRDY] = 1).
  - b. Reading:
    - i. Set up OTP read mode (OTPC\_MODE\_REG[OTPC\_MODE\_MODE] = 0x2).
    - ii. Wait for OTP mode to change (OTPC\_STAT\_REG[OTPC\_STAT\_MRDY] = 1).
    - iii. Read OTP word.
    - iv. Put the OTP in STBY mode (OTPC\_MODE\_REG[OTPC\_MODE\_MODE] = 0x1).
    - v. Wait for OTP mode to change (OTPC\_STAT\_REG[OTPC\_STAT\_MRDY] = 1).



## 12 DMA Controller

### 12.1 Introduction

The 4-channel direct memory access (DMA) controller transfers data of eight bits, 16 bits, or 32 bits between the on-chip supported peripherals (SPI, UART, UART2, I2C, and ADC) and the on-chip RAM and supports regular memory-to-memory transfers. The DMA also supports a programmable interrupt generation to generate an interrupt after a certain number of transfers in order to off load the Cortex interrupt rate. The on-chip peripheral requests are multiplexed on the two available channel pairs to increase the DMA utilization. A block diagram of the controller is depicted on [Figure 18](#).

#### Features

- Four channels with an optional peripheral trigger
- Full 32-bit source and destination pointers
- Flexible interrupt generation
- Programmable length
- Flexible peripheral request per channel
- Option to initialize memory (DMA\_INIT)
- Programmable edge-sensitive request support (recommended when writing to UART/UART2 and I2C)

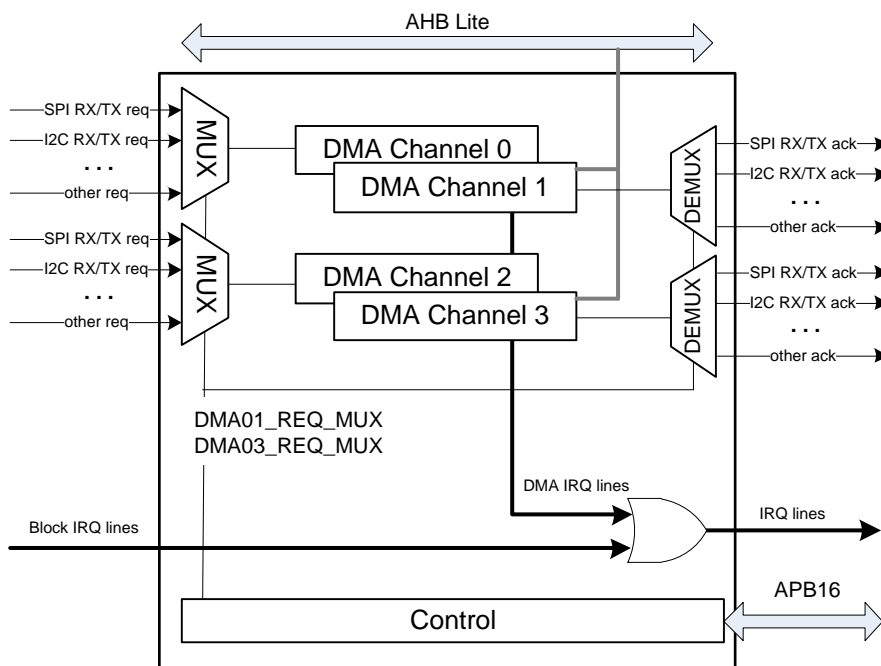

Figure 22: DMA Controller Block Diagram

### 12.2 Architecture

#### 12.2.1 DMA Peripherals

By default, the DMA assumes memory-to-memory transactions. Each DMA channel can also be connected with the hand-shaking signals or other request signals of the corresponding peripherals ([Table 38](#)).

Table 38: DMA Served Peripherals

Name	Direction
SPI	RX/TX
UART	RX/TX
UART2	RX/TX
I2C	RX/TX
GP-ADC	RX

### 12.2.2 Input/Output Multiplexer

The multiplexing of peripheral requests is controlled by DMA\_REQ\_MUX\_REG. Thus, if DMA\_REQ\_MUX\_REG[DMAxy\_SEL] is set to a certain (non-reserved) value, the TX/RX request from the corresponding peripheral will be routed to DMA channels y (TX request) and x (RX request), respectively. Similarly, an acknowledging de-multiplexing mechanism is applied.

When two or more bit-fields (peripheral selectors) of DMA\_REQ\_MUX\_REG have the same value, the lesser significant selector will be given priority (see also the register's description).

### 12.2.3 DMA Channel Operation

A DMA channel is switched on with bit DMA\_ON. This bit is automatically reset if the DMA channel's transfer is finished. The DMA channels can either be triggered by SW or by a peripheral DMA request. If DREQ\_MODE is 0, a DMA channel is immediately triggered.

If DREQ\_MODE is 1, a DMA channel can be triggered by a HW request coming from a selected peripheral. All DMA channels support either level (default) or edge-sensitive requests via the bit-field REQ\_SENSE of DMAx\_CTRL\_REG (x = 0, 1, 2, 3). If this bit-field is set (recommended for Memory-to-UART/UART2 and Memory-to-I2C transfers), the channel detects a positive edge on the request signal of the selected peripheral in order to start up a new transfer cycle. The edge-sensitive requests can be used globally, if desired, for all the peripherals interfacing with the DMA.

When DMA starts, data is transferred from address DMAx\_A\_START\_REG to address DMAx\_B\_START\_REG for a length of DMAx\_LEN\_REG, which can be eight, 16, or 32 bits wide. The address increment is realized with an internal 16-bit counter DMAx\_IDX\_REG, which is set to 0 when the DMA transfer starts and is compared with the DMAx\_LEN\_REG after each transfer. The register value is multiplied by the values of the automatic increment of source address (AINC), the automatic increment of destination address (BINC), and bus transfer width (BW) before it is added to DMAx\_A\_START\_REG and DMAx\_B\_START\_REG. AINC or BINC must be 0 for register access.

If at the end of a DMA cycle, the DMA start condition is still true, the DMA continues. The DMA stops if DREQ\_MODE is low or if DMAx\_LEN\_REG is equal to the internal index register. This condition also clears the DMA\_ON bit if DREQ\_MODE is 0 or if DREQ\_MODE is set to 1 and CIRCULAR bit is not set.

If a hand shaking is attached to the specific DMA channel at the end of a DMA cycle, the channel will be blocked for as long as the peripheral is not ready for the next transaction.

If the bit CIRCULAR is set to 1, the DMA controller automatically resets the internal index registers and continues from its starting address without intervention of the Arm Cortex-M0+. If the DMA controller is started with DREQ\_MODE = 0, the DMA will always stop, regardless of the state of CIRCULAR.

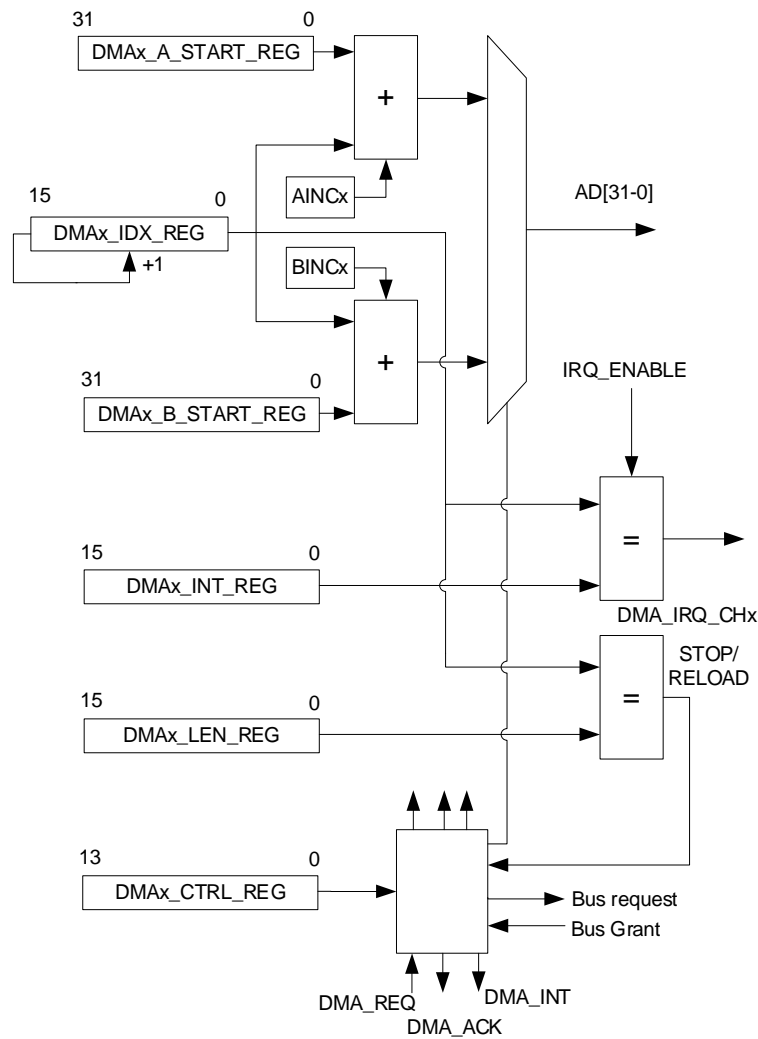

**Figure 23: DMA Channel Diagram**

Each DMA channel can generate an interrupt if the index counter `DMAx_IDX_REG` reaches the value of the channel's interrupt transfer length register, `DMAx_INT_REG`. After the transfer and before `DMAx_IDX_REG` is incremented, the interrupt is generated.

For example, if `DMA_x_INT_REG = 0` and `DMA_x_LEN_REG = 0`, there will be one transfer and an interrupt.

#### 12.2.4 DMA Arbitration

The priority level of a DMA channel can be set with bits `DMA_Prio[2-0]`. These bits determine which DMA channel will be activated if more than one DMA channel requests DMA. If two or more channels have the same priority, an inherent priority applies (see register description).

With `DREQ_MODE = 0`, a DMA can be interrupted by a channel with a higher priority if the `DMA_IDLE` bit is set.

When `DMA_INIT` is set, however, the DMA channel currently performing the transfer locks the bus and cannot be interrupted by any other channels until the transfer is completed, regardless of whether `DMA_IDLE` is set. The purpose of `DMA_INIT` is to initialize a specific memory block with a certain value without any interruption from other active DMA channels that may request the bus at the same time. Consequently, `DMA_INIT` should be used only for memory initialization. When the DMA transfers data to/from peripherals, `DMA_INIT` should be set to 0.

**NOTE**

When DMA\_INIT is enabled, AINC must be set to 0 and BINC to 1.

Memory initialization could also be performed by simply setting AINC to 0 and BINC to 1 without enabling the DMA\_INIT, provided that the source address of the memory will not change during the transfer. However, it is not guaranteed that the DMA transfer will not be interrupted by other channels of a higher priority, when they request access to the bus at the same time.

### 12.2.5 Freezing DMA Channels

Each channel of the DMA controller can be temporarily disabled by writing a 1 to bit 4 SET\_FREEZE\_REG[FRZ\_DMA] to freeze all channels.

To enable a frozen channel again, write a 1 to bit 4 RESET\_FREEZE\_REG[FRZ\_DMA].

There is no HW protection from erroneous programming of the DMA registers.

The on-going Memory-to-Memory transfers (DREQ\_MODE = 0) cannot be interrupted, therefore the corresponding DMA channels are frozen after a Memory-to-Memory transfer is completed.

## 12.3 Programming

### 12.3.1 Memory to Memory Transfers

1. Set the length of data to be transferred (DMAx\_LEN\_REG).
2. Set the source address (DMAx\_A\_START\_REG).
3. Set the destination address (DMAx\_B\_START\_REG).
4. Configure the number of transfers until an interrupt is generated (DMAx\_INT\_REG).
5. Configure transfer options:
  - a. DMAx\_CTRL\_REG[AINC]: Automatic increment of source address.
  - b. DMAx\_CTRL\_REG[BINC]: Automatic increment of destination address.
  - c. DMAx\_CTRL\_REG[BW]: Bus transfer width.
  - d. DMAx\_CTRL\_REG[IRQ\_ENABLE]: Enable the DMA interrupt generation for this channel.
6. Start the DMA transfer by setting the DMAx\_CTRL\_REG[DMA\_ON] bit.
7. Wait until the transfer is finished (DMAx\_CTRL\_REG[DMA\_ON] = 0).
8. Clear the IRQ status bit for channel x in DMA\_INT\_STATUS\_REG.

### 12.3.2 Peripheral to Memory Transfers

1. Set the length of data to be transferred (DMAx\_LEN\_REG).
2. Set the source address (DMAx\_A\_START\_REG) to the peripheral Rx register (for example, I2C\_DATA\_CMD\_REG).
3. Set the destination address (DMAx\_B\_START\_REG). This should point to a buffer in memory (for example, SYSRAM).
4. Configure the number of transfers until an interrupt is generated (DMAx\_INT\_REG).
5. Map the peripheral to the selected channels pair (DMA\_REQ\_MUX\_REG[DMAxy\_SEL]).
6. Configure transfer options:
  - a. DMAx\_CTRL\_REG[AINC]: Disable automatic increment of source address.
  - b. DMAx\_CTRL\_REG[BINC]: Automatic increment of destination address.
  - c. DMAx\_CTRL\_REG[BW]: Bus transfer width.
  - d. DMAx\_CTRL\_REG[DREQ\_MODE]: Enable triggering by peripheral DMA request.
  - e. DMAx\_CTRL\_REG[DMA\_PRIO]: Set the channel's priority.
  - f. DMAx\_CTRL\_REG[IRQ\_ENABLE]: Enable the DMA interrupt generation for this channel.

- g. DMAx\_CTRL\_REG[REQ\_SENSE]: Enable edge-sensitive requests for this channel. This is recommended for Memory-to-UART/UART2/I2C transfers but can also be used globally for all the supported peripherals and for both directions (TX/RX).
7. Start the DMA transfer by setting the DMAx\_CTRL\_REG[DMA\_ON] bit.
8. Enable peripheral's DMA request (for example, I2C\_DMA\_CR\_REG[TDMAE]).
9. Clear the IRQ status bit for channel x in DMA\_INT\_STATUS\_REG.

## 13 I2C Interface

### 13.1 Introduction

The I2C Interface is a programmable control bus that provides support for the communications link between Integrated Circuits in a system. It is a simple two-wire bus with a software-defined protocol for system control, which is used in temperature sensors and voltage level translators to EEPROMs, general-purpose I/O, and A/D and D/A converters.

#### Features

- Two-wire I2C serial interface consisting of a serial data line (SDA) and a serial clock (SCL)
- Two speeds are supported:
  - Standard mode (0 to 100 kbit/s)
  - Fast mode ( $\leq 400$  kbit/s)
- Clock synchronization
- 32 locations deep transmit/receive FIFOs (32x 8-bit Rx and 32x 10-bit Tx)
- Master transmit and Master receive operation
- Slave transmit and Slave receive operation
- 7-bit or 10-bit addressing
- 7-bit or 10-bit combined format transfers
- Bulk transmit mode
- Default slave address of 0x055
- Interrupt or polled-mode operation
- Handles bit and byte waiting at both bus speeds
- Programmable SDA hold time
- DMA support

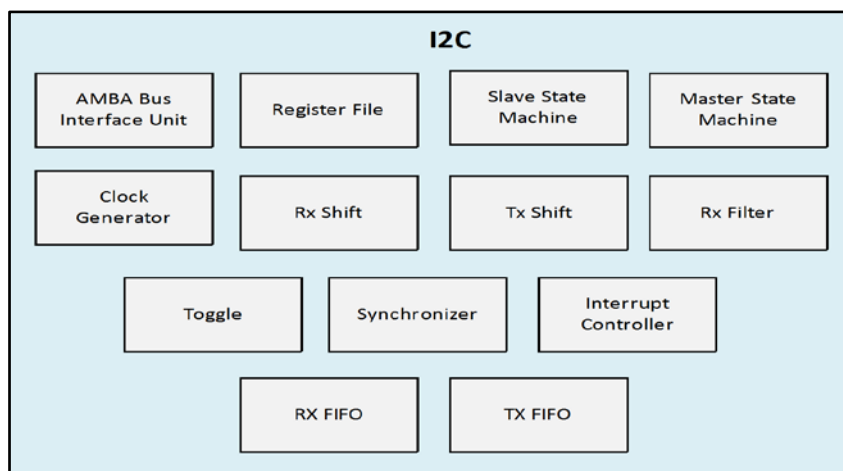

Figure 24: I2C Controller Block Diagram

### 13.2 Architecture

The I2C Controller block diagram is shown in [Figure 24](#). It contains the following sub-blocks:

- **AMBA Bus Interface Unit:** it accesses the register file via the APB interface
- **Register File:** it contains configuration registers and is the interface with SW
- **Master State Machine:** it generates the I2C protocol for the master transfers

- **Slave State Machine:** it generates the I2C protocol for the slave transfers
- **Clock Generator:** it calculates the required time to do the following:
  - Generate the SCL clock when configured as a master
  - Check for bus idle
  - Generate a START and a STOP
  - Set up the data and hold the data
- **Rx Shift:** it takes data into the design and extracts it in byte format
- **Tx Shift:** it presents data supplied by CPU for transfer on the I2C bus
- **Rx Filter:** it detects the events in the bus, for example, start, stop, and arbitration lost
- **Toggle:** it generates pulses on both sides and toggles to transfer signals across clock domains
- **Synchronizer:** it transfers signals from one clock domain to another
- **Interrupt Controller:** it generates the raw interrupt and interrupt flags, allowing them to be set and cleared.
- **RX FIFO/TX FIFO:** it holds the RX FIFO and TX FIFO register banks and controllers along with their status levels.

### 13.2.1 I2C Bus Terms

The following terms relate to what the role of a I2C device is and how it interacts with other I2C devices on the bus.

- **Transmitter** is the device that sends data to the bus. A transmitter can either initiate the data transmission to the bus (a master-transmitter) or respond to a request from the master to send data back (a slave-transmitter)
- **Receiver** is the device that receives data from the bus. A receiver can either receive data on its own request (a master-receiver) or respond to a request from the master to receive data (a slave-receiver)
- **Master** is the component that initializes a transfer (START command), generates the clock (SCL) signal, and terminates the transfer (STOP command). A master can be either a transmitter or a receiver
- **Slave** is the device addressed by the master. A slave can be either a receiver or a transmitter

These concepts are illustrated in [Figure 25](#).

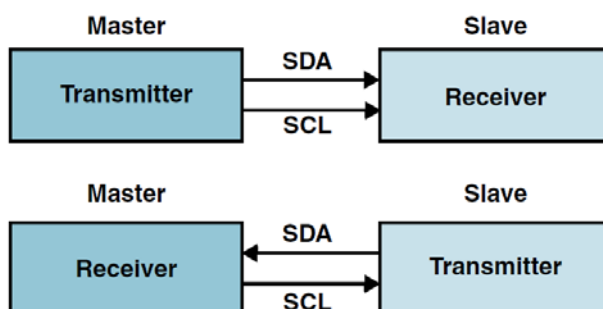

**Figure 25: Master/Slave and Transmitter/Receiver Relationships**

- Multi-master means the ability for more than one master to co-exist on the bus at the same time without collision or data loss
- Arbitration is the predefined procedure that authorizes only one master at a time to take control of the bus. For more information, refer to section [13.2.4](#)
- Synchronization is the predefined procedure that synchronizes the clock signals provided by two or more masters. For more information, refer to section [13.2.5](#)

- SDA is the data signal line (Serial Data)
- SCL is the clock signal line (Serial Clock)

#### 13.2.1.1 Bus Transfer Terms

The following terms are specific to data transfers that occur to/from the I2C bus.

- **START (RESTART).** Data transfer begins with a START or RESTART condition. The level of the SDA data line changes from high to low, while the SCL clock line remains high. When this occurs, the bus becomes busy
- **STOP.** Data transfer is terminated by a STOP condition. This occurs when the level of the SDA data line changes from low to high, while the SCL clock line remains high. When the data transfer has been terminated, the bus is free or idle again. The bus stays busy if a RESTART is generated instead of a STOP condition

<b>NOTE</b>
START and RESTART conditions are functionally identical.

#### 13.2.2 I2C Behavior

The I2C can be only be controlled via SW to be an I2C master, communicating with other I2C slaves. The master is responsible for generating the clock and controlling the transfer of data. The I2C protocol also allows multiple masters to reside on the I2C bus and uses an arbitration procedure to determine the bus ownership. A slave is responsible for either transmitting or receiving data to/from the master. The acknowledgement of data is sent by the device that is receiving data, which can be either a master or a slave.

Each slave has a unique address that is determined by the system designer. When a master wants to communicate with a slave, the master transmits a START/RESTART condition that is then followed by the slave's address and a control bit (R/W) to determine whether the master wants to transmit data or receive data from the slave. The slave then sends an acknowledge pulse (ACK) after the address.

If a master-transmitter writes to a slave-receiver, the receiver gets one byte of data. This transaction continues until the master terminates the transmission with a STOP condition. If a master-receiver reads from a slave-transmitter, the slave transmits a byte of data to the master, and the master then acknowledges the transaction with an ACK pulse. This transaction continues until the master terminates the transmission by not acknowledging (NACK) the transaction after the last byte is received, and then the master issues a STOP condition or addresses another slave after issuing a RESTART condition. This behavior is illustrated in [Figure 26](#).

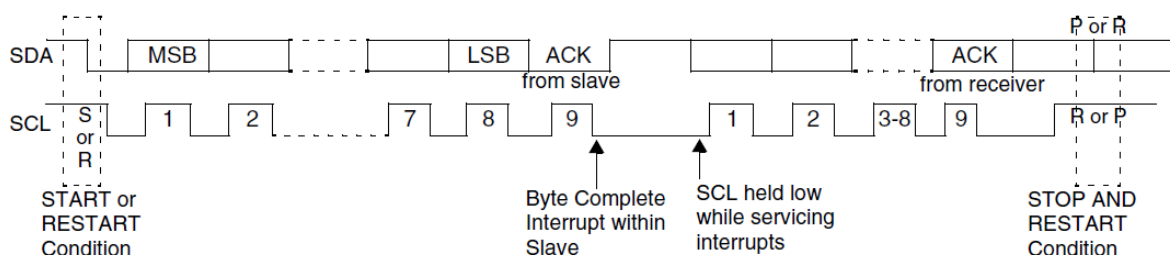

**Figure 26: Data Transfer on the I2C Bus**

The I2C is a synchronous serial interface. The SDA line is a bidirectional signal and changes only when the SCL line is low, except for STOP, START, and RESTART conditions. The output drivers are open-drain or open-collector to perform wire-AND functions on the bus. The maximum number of devices on the bus is limited only by the maximum capacitance specification of 400 pF. Data is transmitted in byte packages.



### 13.2.2.1 START and STOP Generation

When operating as an I2C master, putting data into the transmit FIFO causes the I2C Controller to generate a START condition on the I2C bus. Allowing the transmit FIFO to empty causes the I2C Controller to generate a STOP condition on the I2C bus.

When operating as a slave, the I2C Controller does not generate START or STOP conditions, as per the protocol. However, if a read request is made to the I2C Controller, it holds the SCL line low until read data has been supplied to it. This stalls the I2C bus until read data is provided to the slave I2C Controller, or the I2C Controller slave is disabled by writing a 0 to I2C\_ENABLE.

### 13.2.2.2 Combined Formats

The I2C Controller supports transactions in a read and write combined format in both 7-bit and 10-bit addressing modes.

The I2C Controller does not support mixed address and mixed address format, that is, a 7-bit address transaction followed by a 10-bit address transaction or vice versa.

To initiate combined format transfers, I2C\_CON\_REG[I2C\_RESTART\_EN] should be set to 1. With this value set and the I2C Controller operating as a master, when an I2C transfer is completed, the I2C Controller checks the transmit FIFO and executes the next transfer. If the direction of the new transfer differs from the previous one, the combined format is used to issue the transfer. If the transmit FIFO is empty when the current I2C transfer completes, a STOP is issued, and the next transfer is issued after a START condition.

## 13.2.3 I2C Protocols

The I2C Controller has the following protocols:

- [START and STOP Conditions](#)
- [Addressing Slave Protocol](#)
- [Transmitting and Receiving Protocols](#)
- [START BYTE Transfer Protocol](#)

### 13.2.3.1 START and STOP Conditions

When the bus is idle, both SCL and SDA signals are pulled high through external pull-up resistors on the bus. When a master wants to start a transmission on the bus, it issues a START condition. This is defined to be a high-to-low transition of the SDA signal while SCL is 1. When the master wants to terminate the transmission, it issues a STOP condition. This is defined to be a low-to-high transition of the SDA line while SCL is 1. [Figure 27](#) shows the timing of the START and STOP conditions. When data is being transmitted on the bus, the SDA line must be stable when SCL is 1.

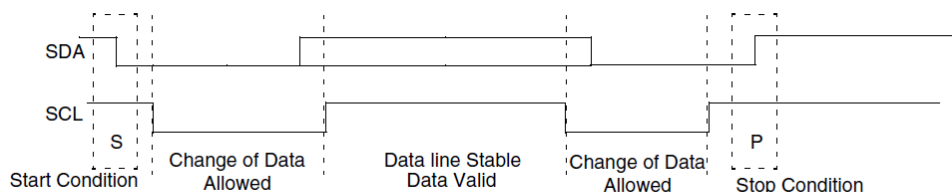

**Figure 27: START and STOP Conditions**

#### NOTE

The signal transitions for the START/STOP conditions ([Figure 27](#)) reflect those observed at the output signals of the master driving the I2C bus. Be careful with observing the SDA/SCL signals at the input signals of the slave(s), because unequal line delays may result in an incorrect SDA/SCL timing relationship.

#### 13.2.3.2 Addressing Slave Protocol

There are two address formats: 7-bit address format and 10-bit address format.

##### 7-bit Address Format

In the 7-bit address format, the first seven bits (bits 7:1) of the first byte set the slave address and the LSB bit (bit 0) is the R/W bit (Figure 28). When bit 0 (R/W) is set to 0, the master writes to the slave. When bit 0 (R/W) is set to 1, the master reads from the slave.

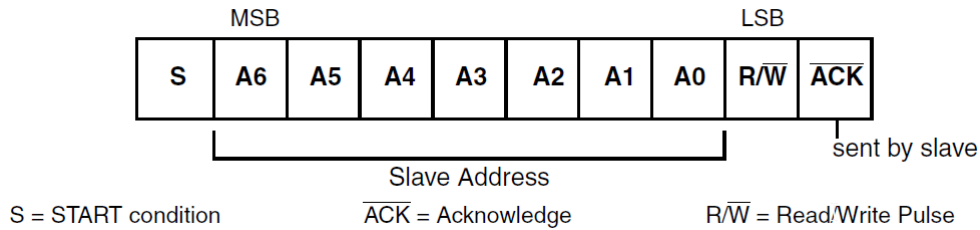

**Figure 28: 7-bit Address Format**

##### 10-bit Address Format

In the 10-bit address format, two bytes are transferred to set the 10-bit address. The transfer of the first byte contains the following bit definition: the first five bits (bits 7:3) notify the slaves that this is a 10-bit transfer, the next two bits (bits 2:1) set the slaves address bits 9:8, and the LSB bit (bit 0) is the R/W bit. The second byte transferred sets bits 7:0 of the slave address. Figure 29 shows the 10-bit address format and Table 39 defines the special purpose and the reserved first byte addresses.

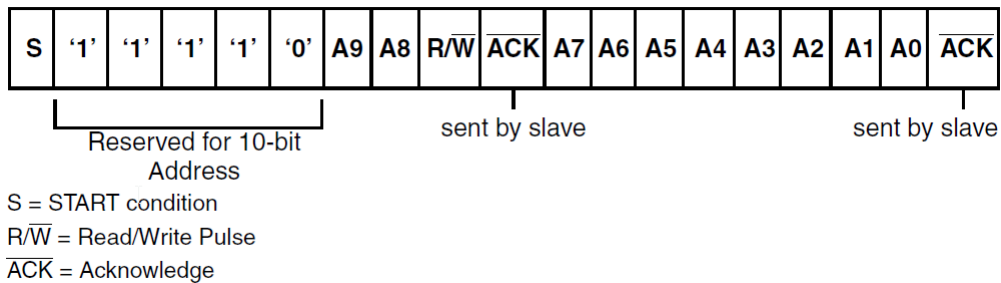

**Figure 29: 10-bit Address Format**

**Table 39: I2C Definition of Bits in First Byte in 10-bit Address Format**

Slave Address	R/W Bits	Description
0000 000	0	General Call Address. I2C Controller places the data in the receive buffer and issues a General Call interrupt.
0000 000	1	START byte. For more details, refer to " <a href="#">START BYTE Transfer Protocol</a> ".
0000 001	X	CBUS address. I2C Controller ignores these accesses.
0000 010	X	Reserved.
0000 011	X	Reserved.
0000 1XX	X	Reserved
1111 1XX	X	Reserved.
1111 0XX	X	10-bit slave addressing.

The I2C Controller does not restrict users from using these reserved addresses. However, if these reserved addresses are used, incompatibilities with other I2C components may occur.

### 13.2.3.3 Transmitting and Receiving Protocols

A master can initiate data transmission and reception to/from the bus, acting as either a master-transmitter or master-receiver. A slave responds to requests from a master to either transmit data or receive data to/from the bus, acting as either a slave-transmitter or slave-receiver.

#### Master-Transmitter and Slave-Receiver

All data is transmitted in byte format with no limit on the number of bytes transferred per data transfer. After a master sends a slave address and a R/W bit or a master transmits a byte of data to a slave, the slave-receiver must respond with an acknowledge signal (ACK). When a slave-receiver does not respond with an ACK signal, the master aborts the transfer by issuing a STOP condition. The slave must leave the SDA line high so that the master can abort the transfer.

If a master-transmitter is transmitting data as shown in [Figure 30](#), the slave-receiver responds to the master-transmitter with an ACK signal after every byte of data is received.

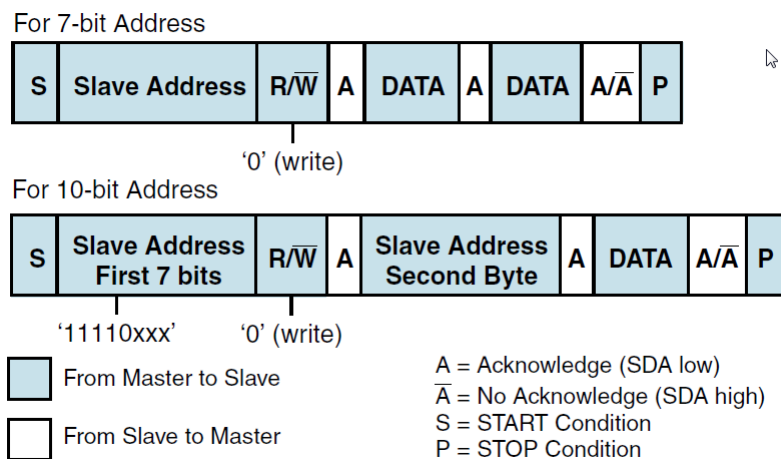

**Figure 30: Master-Transmitter Protocol**

#### Master-Receiver and Slave-Transmitter

If a master is receiving data as shown in [Figure 31](#), the master responds to the slave-transmitter with an ACK signal after a byte of data has been received except for the last byte. This is the way the master-receiver notifies the slave-transmitter that this is the last byte. The slave-transmitter relinquishes the SDA line after detecting the No Acknowledge (NACK) so that the master can issue a STOP condition.

When a master does not want to relinquish the bus with a STOP condition, the master can issue a RESTART condition. This is identical to a START condition except it occurs after the ACK signal. The master can then communicate with the same slave or a different slave.

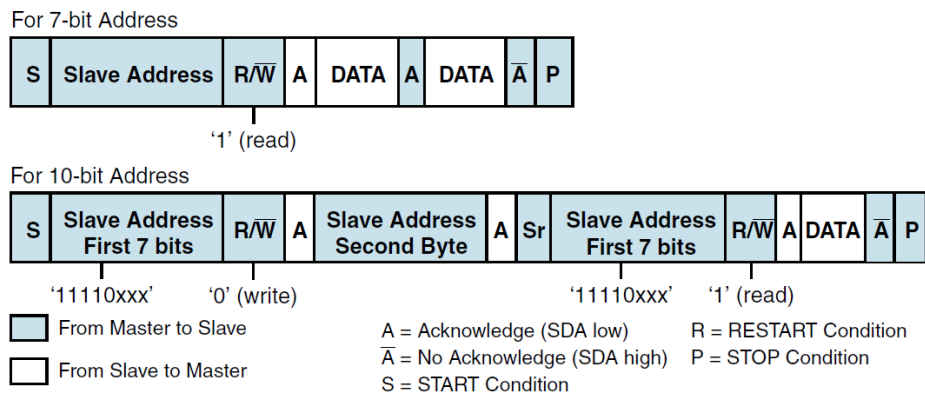

Figure 31: Master-Receiver Protocol

### START BYTE Transfer Protocol

The START BYTE transfer protocol is set up for systems that do not have an on-board dedicated I2C hardware module. When the I2C Controller is addressed as a slave, it always samples the I2C bus at the highest speed supported so that it never requires a START BYTE transfer. However, when I2C Controller is a master, it supports the generation of START BYTE transfers at the beginning of every transfer in case a slave device requires it. This protocol consists of seven zeros followed by a 1 being transmitted (Figure 32). This allows the processor that is polling the bus to under-sample the address phase until 0 is detected. Once the microcontroller detects a 0, it switches from the under-sampling rate to the correct rate of the master.

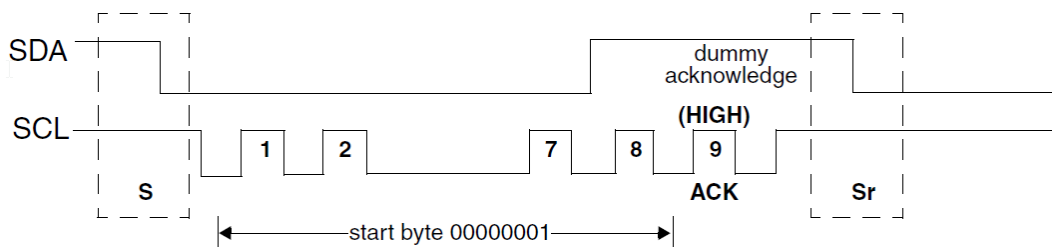

Figure 32: START BYTE Transfer

The START BYTE procedure is as follows:

1. Master generates a START condition.
2. Master transmits the START byte (0000 0001).
3. Master transmits the ACK clock pulse. (Present only to conform with the byte handling format used on the bus)
4. No slave sets the ACK signal to 0.
5. Master generates a RESTART (R) condition.

A hardware receiver does not respond to the START BYTE because it is a reserved address and gets reset after the RESTART condition is generated.

### 13.2.4 Multiple Master Arbitration

The I2C Controller allows multiple masters to reside on the same bus. There is an arbitration procedure if two masters on the same I2C bus try to control the bus at the same time by generating a START condition simultaneously. Once a master (for example, a microcontroller) has control of the bus, no other master can take control until the first master sends a STOP condition and places the bus in an idle state.

Arbitration takes place on the SDA line while the SCL line is 1. The master which transmits a 1 while the other master transmits a 0 loses the arbitration and turns off its data output stage. The master that has lost the arbitration can continue to generate clocks until the end of the byte transfer. If both masters are addressing the same slave device, the arbitration could go into the data phase. [Figure 33](#) illustrates the timing of an arbitration between two masters on the bus.

Control of the bus is determined by the address or master code and data sent by the competing masters, so there is no central master or any order of priority on the bus.

Arbitration is not allowed between the following conditions:

- A RESTART condition and a data bit
- A STOP condition and a data bit
- A RESTART condition and a STOP condition

Slaves are not involved in the arbitration process.

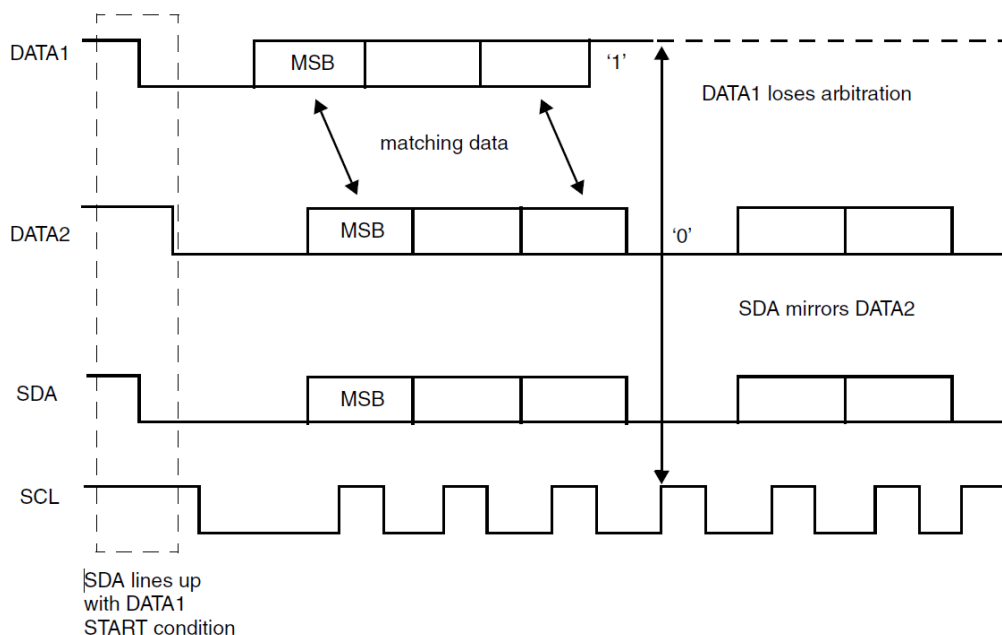
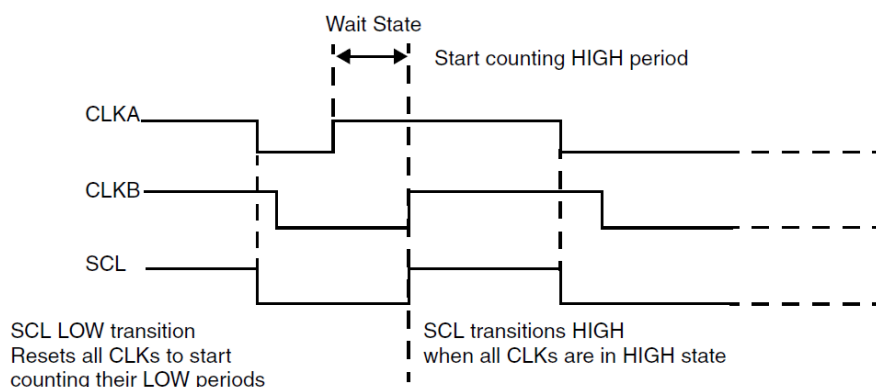

**Figure 33: Multiple Master Arbitration**

### 13.2.5 Clock Synchronization

All masters generate their own clock to transfer messages. Data is only valid during the HIGH period of the SCL clock. When two or more masters try to transfer information on the bus at the same time, they must synchronize the SCL clock. Clock synchronization is performed using the wired-AND connection to the SCL signal. When the master transitions the SCL clock to 0, the master starts counting the LOW period of the SCL clock and transitions the SCL clock signal to 1 at the beginning of the next clock period. However, if another master is holding the SCL line to 0, the first master goes into a HIGH wait state until the SCL clock line transitions to 1.

All masters then count out their HIGH time and the master with the shortest HIGH time transitions the SCL line to 0. The masters then count out their LOW time and the one with the longest LOW time forces the other master into a HIGH wait state. Therefore, a synchronized SCL clock is generated, which is illustrated in [Figure 34](#). Optionally, slaves may hold the SCL line LOW to slow down the timing on the I2C bus.



**Figure 34: Multiple Master Clock Synchronization**

### 13.3 Programming

To configure and use the I2C Controller, follow the simple sequence of steps below:

1. Set up the GPIOs to be used for the I2C interface ( $P0x\_MODE\_REG[PID] = 9$  or  $10$ ).
2. Enable the clock for the I2C Controller ( $CLK\_PER\_REG[I2C\_ENABLE] = 0x1$ ).
3. Disable the I2C Controller ( $I2C\_ENABLE\_REG = 0$ ).
4. Configure the I2C clock frequency:
  - a. Standard mode (100 kbit/s) :  $I2C\_CON\_REG[I2C\_SPEED] = 1$ .
  - b. Full speed mode (400 kbit/s) :  $I2C\_CON\_REG[I2C\_SPEED] = 2$ .
5. Setup the I2C Controller as:
  - a. Master:  $I2C\_CON\_REG[I2C\_MASTER\_MODE] = 1$  and  $I2C\_CON\_REG[I2C\_SLAVE\_DISABLE] = 1$ .
  - b. Slave:  $I2C\_CON\_REG[I2C\_MASTER\_MODE] = 0$  and  $I2C\_CON\_REG[I2C\_SLAVE\_DISABLE] = 0$ .
6. Choose whether the controller starts its transfers in the 7-bit or 10-bit addressing format when acting as a master ( $I2C\_CON\_REG[I2C\_10BITADDR\_MASTER]$ ) or whether the controller responds to the 7-bit or 10-bit addresses when acting as a slave ( $I2C\_CON\_REG[I2C\_10BITADDR\_SLAVE]$ ).
7. Set target slave address in:
  - a. Master mode ( $I2C\_TAR\_REG[IC\_TAR] = 0x55$  (default)).
  - b. Slave mode ( $I2C\_SAR\_REG[IC\_SAR] = 0x55$  (default)).
8. Set the threshold levels on RX and TX FIFO ( $I2C\_RX\_TL\_REG$  and  $I2C\_TX\_TL\_REG$ ).
9. Enable the required interrupts ( $I2C\_INTR\_MASK\_REG$ ).
10. Enable the I2C Controller ( $I2C\_ENABLE\_REG = 0x1$ ).
11. Read a byte:
  - a. Prepare to transmit the read command byte ( $I2C\_DATA\_CMD\_REG[I2C\_CMD] = 1$ ).
  - b. Wait until TX FIFO is empty ( $I2C\_STATUS\_REG[TFE] = 1$ ).
  - c. Wait until master has finished reading the byte from slave device ( $I2C\_STATUS\_REG[MST\_ACTIVITY] = 0$ ).
12. Write a byte:
  - a. Prepare to transmit the write command byte ( $I2C\_DATA\_CMD\_REG[I2C\_CMD] = 0$  and  $I2C\_DATA\_CMD\_REG[I2C\_DAT] = \text{command byte}$ ).
  - b. Wait until TX FIFO is empty ( $I2C\_STATUS\_REG[TFE] = 1$ ).
  - c. Wait until master has finished reading the response byte from slave device ( $I2C\_STATUS\_REG[MST\_ACTIVITY] = 0$ ).

## 14 UART

### 14.1 Introduction

The DA14530 contains two instances of the UART block, that is, UART and UART2.

The UART is compliant to the industry-standard 16550 and is used for serial communication with a peripheral. Data is written from a master (CPU) over the APB bus to the UART and it is converted to the serial form and transmitted to the destination device. Serial data is also received by the UART and stored for the master (CPU) to read back.

There is also DMA support on the UART block, thus the internal FIFOs can be used. Only UART supports the hardware flow control signals (RTS and CTS) and the 9-bit mode.

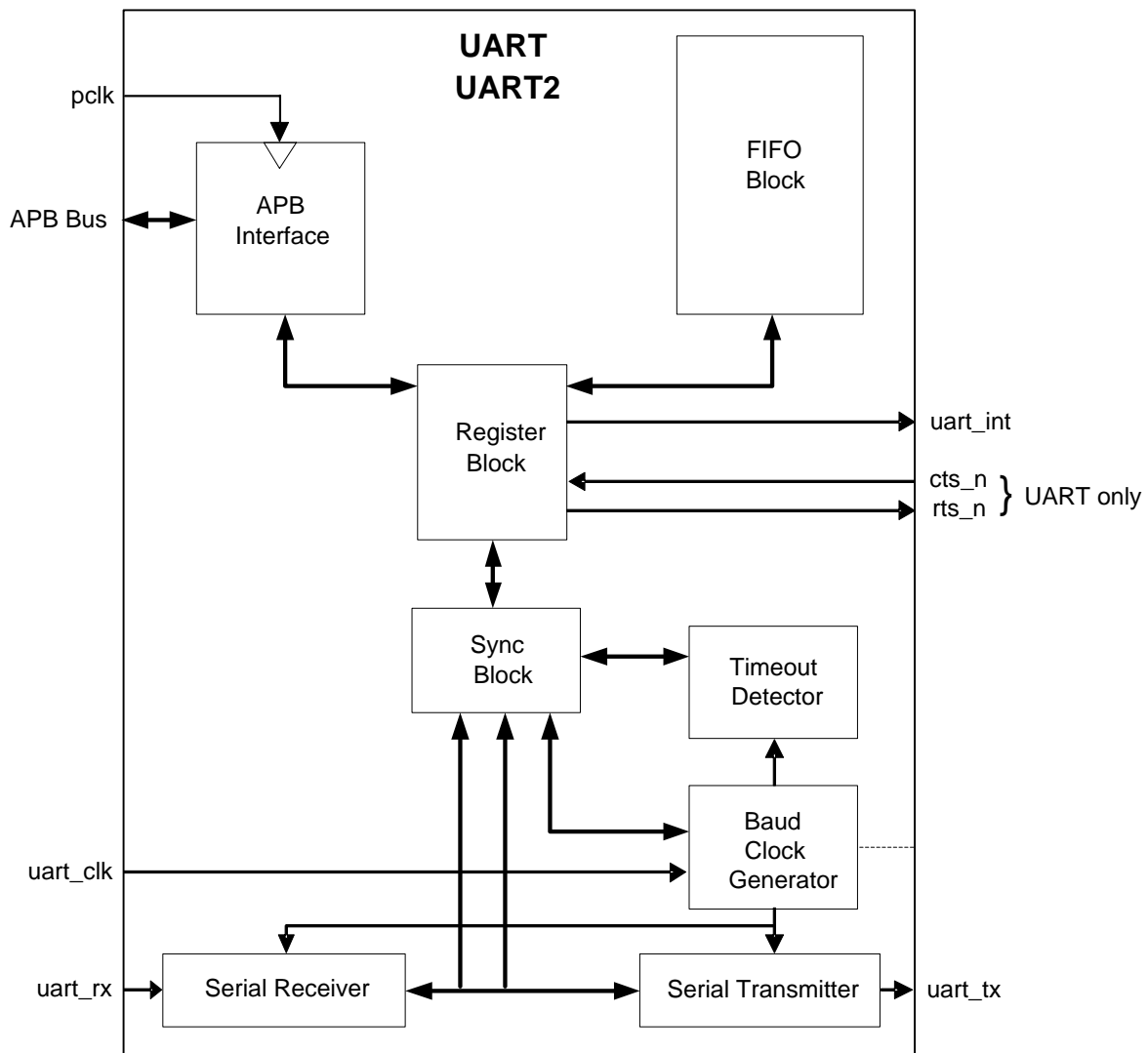

Figure 35: UART Block Diagram

#### Features

- 16-byte transmit and receive FIFOs
- Hardware flow control (CTS/RTS) (UART only)
- Shadow registers to reduce software overhead and a software programmable reset is included
- Transmitter Holding Register Empty (THRE) interrupt mode

- Functionality based on the 16550 industry standard:
  - Programmable character properties, such as number of data bits per character (5-8) (optional)
  - Parity bit (with odd or even select) and number of stop bits (1, 1.5, or 2)
  - Line break generation and detection
  - Prioritized interrupt identification
- Programmable serial data baud rate

## 14.2 Architecture

### 14.2.1 UART (RS232) Serial Protocol

Because the serial communication between the UART and the selected device is asynchronous, additional bits (start and stop) are added to the serial data to indicate the beginning and end. Utilizing these bits allows two devices to be synchronized. This structure of serial data accompanied by the start and stop bits is referred to as a character (Figure 36).

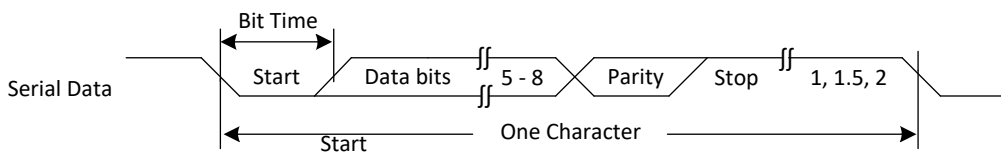

Figure 36: Serial Data Format

An additional parity bit may be added to the serial character. This bit appears after the last data bit and before the stop bit(s) in the character structure to provide the UART with the ability to perform simple error checking on the received data.

The UART Line Control Register (UART\_LCR\_REG) is used to control the serial character characteristics. The individual bits of the data word are sent after the start bit, starting with the least-significant bit (LSB). These are followed by the optional parity bit and then by the stop bit(s), which can be of 1, 1.5, or 2 bits.

All the bits in the transmission (except the half stop bit when the 1.5 stop bits are used) are transmitted for exactly the same time duration. This is referred to as a Bit Period or Bit Time. One Bit Time equals to 16 baud clocks. To ensure stability on the line, the receiver samples the serial input data at approximately the mid-point of the Bit Time, once the start bit has been detected. As the exact number of baud clocks that each bit has been transmitted for is known, the mid-point for sampling is every 16 baud clocks after the mid-point sample of the start bit. Figure 37 shows the sampling points of the first couple of bits in a serial character.

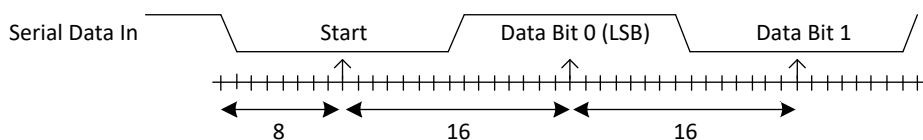

Figure 37: Receiver Serial Data Sampling Points

As part of the 16550 standard, an optional baud clock reference output signal (baudout\_n) is supplied to provide timing information to the receiving devices that require it. The baud rate of the UART is controlled by the serial clock (*sclk* or *pcik* in a single clock implementation) and the Divisor Latch Register (DLH and DLL) in the following equation:

$$\text{baud rate} = (\text{serial clock frequency}) / (16 \times \text{divisor}) \quad (2)$$



where the divisor is a 16-bit integer value plus 4-bit fractional value. The divisor range is 0 to 65535,9375 with steps of 1/16. Divisor High 8-bit integer part is in the DLH register. Divisor Low 8-bit integer part is in the DLL register. Divisor 4-bit fractional part is in the DLF register.

The registers settings for the common baud rate values are presented in [Table 40](#).

**Table 40: UART Baud Rate Generation**

Baud Rate	Divider	Divisor Latch	DLH Reg	DLL Reg	DLF Reg	Actual BR	Error (%)
1200	833,333	833,3125	3	65	5	1200,03	0,00
2400	416,667	416,6875	1	160	11	2399,88	0,00
4800	208,333	208,3125	0	208	5	4800,48	0,01
9600	104,167	104,1875	0	104	3	9598,08	0,02
19200	52,083	52,0625	0	52	1	19207,68	0,04
38400	26,042	26,0625	0	26	1	38369,30	0,08
57600	17,361	17,375	0	17	6	57553,96	0,08
115200	8,681	8,6875	0	8	11	115107,91	0,08
230400	4,340	4,3125	0	4	5	231884,06	0,64
460800	2,170	2,1875	0	2	3	457142,86	0,79
921600	1,085	1,0625	0	1	1	941176,47	2,12
1000000	1	1	0	1	0	1000000	0,00

### 14.2.2 Clock Support

The UART has two system clocks (*pclk* and *sclk*). Having a second asynchronous serial clock (*sclk*) allows for accurate serial baud rate settings and meeting APB bus interface requirements.

With the two-clock design, a synchronization module is implemented to synchronize all controls and data across the two system clock boundaries.

Although a serial clock faster than four-times the *pclk* does not leave enough time for a complete incoming character to be received and pushed into the receiver FIFO, in most cases the *pclk* signal is faster than the serial clock and this should never be an issue.

The serial clock modules must have time to see new register values and reset their respective state machines. This total time is guaranteed to be no more than eight clock cycles of the slower of the two system clocks. Therefore, no data should be transmitted or received before this maximum time expires after the initial configuration of the UART.

### 14.2.3 Interrupts

The assertion of the UART interrupt (UART\_INT) occurs whenever one of the several prioritized interrupt types are enabled and active. The following interrupt types can be enabled with the IER register:

- Receiver Error
- Receiver Data Available
- Character Timeout (in FIFO mode only)
- Transmitter Holding Register Empty at/below threshold (in Programmable THRE interrupt mode)

When an interrupt occurs, the master accesses the UART\_IIR\_REG to determine the source of the interrupt before dealing with it accordingly. These interrupt types are described in more detail in [Table 41](#).

Table 41: UART Interrupt Priorities

Interrupt ID Bits [3-0]	Interrupt Set and Reset Functions			
	Priority	Interrupt Type	Interrupt Source	Interrupt Reset Control
0001	-	None		
0110	Highest	Receiver Line status	Overrun/parity/framing errors or break interrupt	Reading the line status register
0100	1	Receiver Data Available	Receiver data available (non-FIFO mode or FIFOs disabled) or RCVR FIFO trigger level reached (FIFO mode and FIFOs enabled)	Reading the receiver buffer register (non-FIFO mode or FIFOs disabled) or the FIFO drops below the trigger level (FIFO mode and FIFOs enabled)
1100	2	Character timeout indication	No characters in or out of the RCVR FIFO during the last four character times and there is at least one character in it during this time.	Reading the receiver buffer register
0010	3	Transmitter holding register empty	Transmitter holding register empty (Prog. THRE Mode disabled) or XMIT FIFO at or below threshold (Prog. THRE Mode enabled).	Reading the IIR register to check whether there is an interrupt and what its source is; or, writing into THR (FIFOs or THRE Mode not selected or disabled) or XMIT FIFO above threshold (FIFOs and THRE Mode selected and enabled).
0000	4	Reserved		
0111	Lowest	Reserved	-	-

#### 14.2.4 Programmable THRE Interrupt

The UART can be configured to have a Programmable THRE Interrupt mode available to increase system performance.

When Programmable THRE Interrupt mode is selected, it can be enabled via the Interrupt Enable Register (IER[7]). When FIFOs and the THRE Mode are implemented and enabled, THRE Interrupts are active at and below a programmed transmitter FIFO empty threshold level, as shown in the flowchart in [Figure 38](#). [Figure 39](#) shows the programmed transmitter FIFO empty threshold level, where THRE Interrupts are active when the FIFO is empty. In this case the programmable THRE interrupt mode is disabled.

This threshold level is programmed into FCR[5:4]. The available empty thresholds are: empty, 2,  $\frac{1}{4}$ , and  $\frac{1}{2}$ . See UART\_FCR\_REG for threshold setting details. Selection of the best threshold value depends on the system's ability to begin a new transmission sequence in a timely manner. However, one of these thresholds should prove optimum in increasing system performance by preventing the transmitter FIFO from running empty.

In addition to the interrupt change, Line Status Register (LSR[5]) also switches its function from indicating transmitter FIFO empty to FIFO full. This allows software to fill the FIFO in each transmit sequence by polling LSR[5] before writing another character. Instead of waiting until the FIFO is completely empty, the flow becomes "fill transmitter FIFO whenever an interrupt occurs and there is data to transmit". Waiting until the FIFO is empty causes a performance hit whenever the system is too busy to respond immediately.

Even if everything else is selected and enabled, if the FIFOs are disabled via FCR[0], the Programmable THRE Interrupt mode is also disabled. When not selected or disabled, THRE

interrupts and LSR[5] function normally (both reflecting an empty THR or FIFO). The flowchart of THRE interrupt generation when not in programmable THRE interrupt mode is shown in [Figure 39](#).

For the THRE interrupt to be controlled as

shown here, the following must be true:

- FIFO\_MODE!=NONE
- THRE\_MODE==Enabled
- FIFOs enabled (FCR[0]==1)
- THRE mode enabled (IER[7]==1)

Under the condition that there are no other pending interrupts, the interrupt signal (intr) is asserted

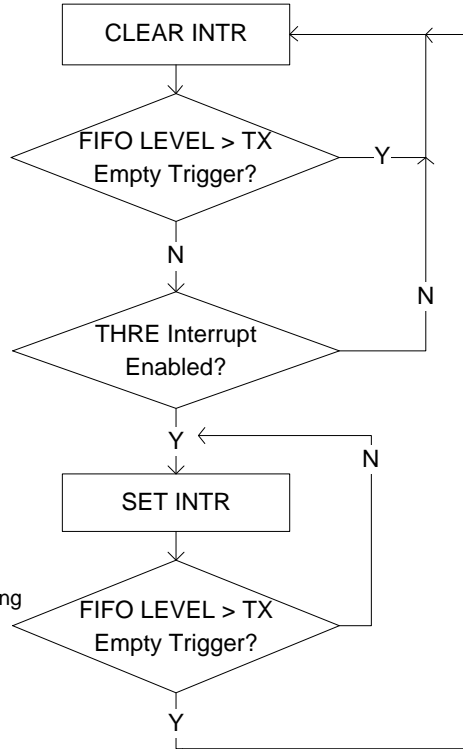

**Figure 38: Flowchart of Interrupt Generation for Programmable THRE Interrupt Mode**

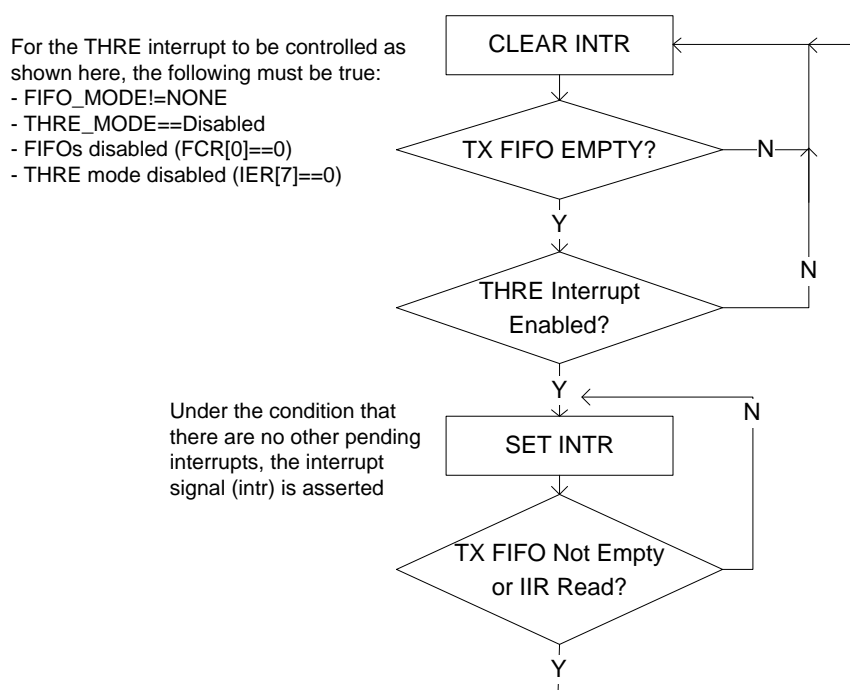

**Figure 39: Flowchart of Interrupt Generation When Not in Programmable THRE Interrupt Mode**

### 14.2.5 Shadow Registers

The shadow registers shadow some of the existing register bits that are regularly modified by software. These can be used to reduce the software overhead that is introduced by having to perform read-modify-writes.

- UART\_SRBR\_REG support a host burst mode where the host increments its address but still accesses the same receive buffer register
- UART\_STHR support a host burst mode where the host increments its address but still accesses the same transmit holding register
- UART\_SFE\_REG accesses the FCR[0] register without accessing the other UART\_FCR\_REG bits
- UART\_SRT\_REG accesses the FCR[7-6] register without accessing the other UART\_FCR\_REG bits
- UART\_STER\_REG accesses the FCR[5-4] register without accessing the other UART\_FCR\_REG bits

### 14.2.6 Direct Test Mode

The on-chip UARTs can be used for the Direct Test Mode required for the final product PHY layer testing. It can be done either over the HCI layer, which engages a full CTS/RTS UART, or by using a 2-wire UART directly as described in the *Bluetooth Low Energy Specification (Volume 6, Part F)*.

## 14.3 Programming

To configure and use the UART controllers, follow the simple sequence of steps below:

1. Set up the GPIOs to be used for the UART interface (P0x\_MODE\_REG[PID] = 1 to 4 and/or 19-20).
2. Enable the selected UART by setting the CLK\_PER\_REG[UARTx\_ENABLE] bit.

3. Enable access to Divisor Latch Registers (DLL and DLH) by setting the UARTx\_LCR\_REG[UART\_DLAB] bit.
4. Set the desired baud rate. To calculate the registers values for the desired baud rate, use the following equation:

$$\text{Divisor} = \text{UART CLK}/(16 \times \text{Baud rate}) \quad (3)$$

- a. UARTx\_IER\_DLH\_REG: High byte of the Divisor integer part.
  - b. UARTx\_RBR\_THR\_DLL\_REG: Low byte of the Divisor integer part.
  - c. UARTx\_DLF\_REG: The fractional part of the Divisor.
5. Configure the break control bit, parity, number of stop bits, and data length (UARTx\_LCR\_REG).
  6. Enable and configure the FIFO (UARTx\_IIR\_FCR\_REG).
  7. Configure the generated interrupts, if needed (UARTx\_IER\_DLH\_REG).
  8. Send a byte:
    - a. Check if Transmit Hold Register (THR) is empty (UARTx\_LSR\_REG[UART\_THRE]).
    - b. Load the byte to THR (UARTx\_RBR\_THR\_DLL\_REG).
    - c. Check if the byte has been transmitted (UARTx\_LSR\_REG[UART\_TEMT]).
  9. Receive a byte:
    - a. Wait until serial data is ready (UARTx\_LSR\_REG[UART\_DR]).
    - b. Read the incoming byte from the THR (UARTx\_RBR\_THR\_DLL\_REG).

## 15 SPI Interface

### 15.1 Introduction

This controller implements the Serial Peripheral Interface (SPI™)<sup>1</sup> for master and slave modes. The serial interface can transmit and receive from four bits to up to 32 bits in master/slave mode. The controller comprises separate TX and RX FIFOs and DMA handshake support. Slave mode clock speed is independent from the system clock speed. Moreover, master's clock speed can be as fast as the system's clock speed. The controller can generate an interrupt upon data threshold reached in the TX or RX FIFOs.

#### Features

- Slave and master mode
- From 4-bit to up to 32-bit operation
- SPI Master clock line speed up to 32 MHz, SPI Slave clock line speed up to 16 MHz
- SPI mode 0, 1, 2, and 3 support (clock edge and phase)
- Built-in separate 8-bit wide and 4-byte deep RX/TX FIFOs for continuous SPI bursts
- Maskable interrupt generation based on TX or RX FIFO thresholds
- DMA support

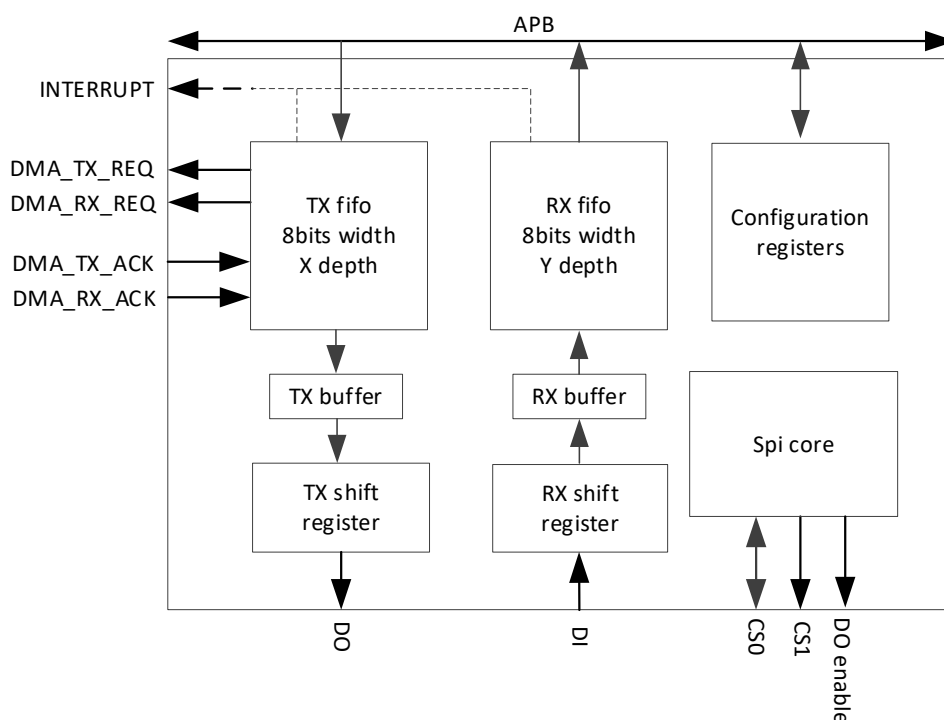

Figure 40: SPI Block Diagram

<sup>1</sup> SPI is a trademark of Motorola, Inc.

## 15.2 Architecture

The SPI controller is an APB peripheral operating on the `apb_clk` clock. It contains a front end which is clocked by the `spi_clk` clock and is responsible for the serialization/deserialization of the data in the RX and TX streams.

Two separate FIFOs, each of eight bits wide and four bytes deep, are used to store data for RX and TX streams. Since a SPI word can be configured to be from four bits to up to 32 bits, one to four FIFO positions can be written/read at the same time. FIFOs contain logic implementing programmable thresholds comparison.

The SPI controller supports DMA requests and interrupt generation based on the FIFO thresholds. If enabled, a DMA request and/or interrupt will be asserted with whether TX\_FIFO level is low or RX\_FIFO level is high.

The SPI interface supports all four modes of operation and the corresponding polarity (CPOL) and phase (CPHA) of the SPI clock (SPI\_CLK) are defined in [Table 42](#).

**Table 42: SPI Modes Configuration and SCK States**

SPI Mode	CPOL	CHPA	TX SPI_CLK	RX SPI_CLK	Idle SPI_CLK
0	0	0	Falling edge	Rising edge	Low
1	0	1	Rising edge	Falling edge	Low
2	1	0	Rising edge	Falling edge	High
3	1	1	Falling edge	Rising edge	High

To read from or to write to an external single byte FLASH device in the SPI master mode, a byte swap mechanism is implemented to allow for a proper placement of the bytes in a 16-bit word for the DMA to write to/read from the internal RAM. More specifically, when the SPI controller is configured as a master with DMA support and a 16-bit word width so that the bus utilization is increased compared to reading from an 8-bit device, the byte swap mechanism brings the least significant byte read and place it in the most significant byte in the 16-bit word. The controller automatically swaps the bytes to allow for placing the first byte read in the least significant byte of the 16-bit word. This feature is programmable via `SPI_CTRL_REG[SPI_SWAP_BYTES]`.

The SPI controller can operate at the highest speed (32 MHz on the SPI\_CLK line) in a special master mode. The clock of the controller is then either the XTAL32M or the RC32M and can be used for fast booting from external FLASH devices that support this frequency.

### 15.2.1 SPI Timing

The timing of the SPI interface when the SPI controller is in slave mode is presented in [Figure 41](#).

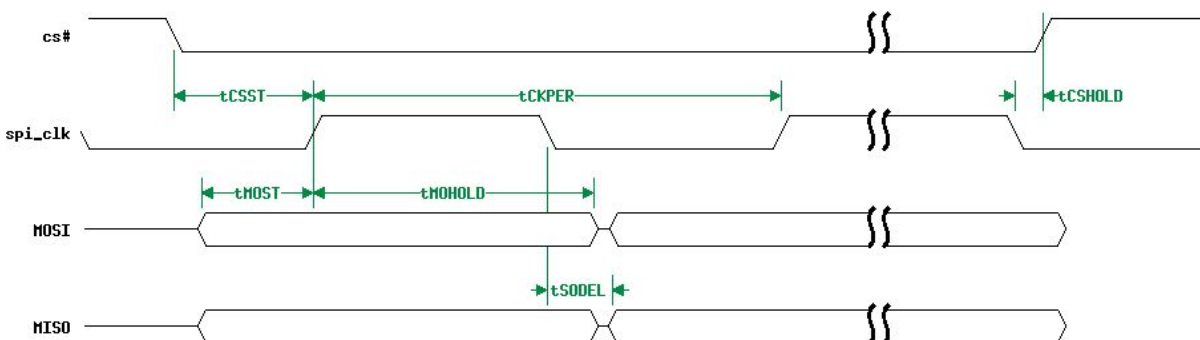

**Figure 41: SPI Slave Mode Timing (CPOL = 0, CPHA = 0)**

Table 43: SPI Timing Parameters

Parameter	Description	Typ	Unit
tCKPER	spi_clk clock period	60	ns
tCSST	CS active time before the first edge of spi_clk	1 spi_clk cycle	
tCSHOLD	CS non-active time after the last edge of spi_clk	1 spi_clk cycle	
tMOST	Master input data latching setup time	(spi_clk/2) - 5	ns
tMOHOLD	Master input data hold time	0	ns
tsODEL	Slave output data delay	25	ns

## 15.3 Programming

### 15.3.1 Master Mode

To configure the SPI controller in master mode, follow the steps below:

1. Set the appropriate GPIO ports in SPI clock mode (output), SPI Chip Select mode (output), SPI Data Out mode (output), and SPI Data In mode (input).
2. Enable SPI clock by setting CLK\_PER\_REG[SPI\_ENABLE] = 1.
3. Reset SPI FIFO by setting SPI\_CTRL\_REG[SPI\_FIFO\_RESET] = 1.
4. Set the SPI clock mode (synchronous or asynchronous with APB clock) by programming SPI\_CLOCK\_REG[SPI\_MASTER\_CLK\_MODE].
5. Set the SPI clock frequency by programming SPI\_CLOCK\_REG[SPI\_CLK\_DIV]. If SPI\_CLK\_DIV is not 0x7F, SPI\_CLK = module\_clk/2 x (SPI\_CLK\_DIV + 1). If SPI\_CLK\_DIV = 0x7F, SPI\_CLK = module\_clk.
6. Set the SPI mode (CPOL or CPHA) by programming SPI\_CONFIG\_REG[SPI\_MODE].
7. Set the SPI controller in master mode by setting SPI\_CONFIG\_REG[SPI\_SLAVE\_EN] = 0.
8. Define the SPI word length (from 4-bit to 32-bit) by programming SPI\_CONFIG\_REG[SPI\_WORD\_LENGTH]. SPI\_WORD\_LENGTH = word length - 1.

To read/write the following sequence has to be performed:

1. If a slave device is slow and does not give the data at the correct clock edge, configure the SPI module to capture data at the next clock edge by setting SPI\_CTRL\_REG[SPI\_CAPTURE\_AT\_NEXT\_EDGE] = 1. Otherwise, set SPI\_CTRL\_REG[SPI\_CAPTURE\_AT\_NEXT\_EDGE] = 0.
2. Release FIFO reset by setting SPI\_CTRL\_REG[SPI\_FIFO\_RESET] = 0.
3. Enable SPI TX path by setting SPI\_CTRL\_REG[SPI\_TX\_EN] = 1.
4. Enable SPI RX path by setting SPI\_CTRL\_REG[SPI\_RX\_EN] = 1.
5. Enable the SPI chip select by programming the SPI\_CS\_CONFIG\_REG[SPI\_CS\_SELECT] = 1 or 2. This option allows the master to select the slave that is connected to the GPIO that has the function of SPI\_CS0 or SPI\_CS1.
6. Enable the SPI controller by setting SPI\_CTRL\_REG[SPI\_EN] = 1.
7. Write to TX FIFO by programming SPI\_FIFO\_WRITE\_REG[SPI\_FIFO\_WRITE]. Write access is permitted only when SPI\_FIFO\_STATUS\_REG[SPI\_TX\_FIFO\_FULL] = 0.
8. Read from RX FIFO by programming SPI\_FIFO\_READ\_REG[SPI\_FIFO\_READ]. Read is permitted only when SPI\_FIFO\_STATUS\_REG[SPI\_RX\_FIFO\_EMPTY] = 0.
9. To disable the SPI chip select, set SPI\_CS\_CONFIG\_REG[SPI\_CS\_SELECT] = 0 to deselect the slave and set SPI\_CTRL\_REG[SPI\_FIFO\_RESET] = 1 to reset the SPI FIFO.



### 15.3.2 Slave Mode

1. Set the appropriate GPIO ports in SPI clock mode (input), SPI Chip Select mode (input), SPI Data Out mode (output), and SPI Data In mode (input).
2. Enable SPI clock by setting `CLK_PER_REG[SPI_ENABLE] = 1`.
3. Reset SPI FIFO by setting `SPI_CTRL_REG[SPI_FIFO_RESET] = 1`.
4. Set the SPI mode (CPOL or CPHA) by programming `SPI_CONFIG_REG[SPI_MODE]`.
5. Set the SPI module in slave controller by setting `SPI_CONFIG_REG[SPI_SLAVE_EN] = 1`.
6. Define the SPI word length (from 4-bit to 32-bit) by programming `SPI_CONFIG_REG[SPI_WORD_LENGTH]`. `SPI_WORD_LENGTH = word length - 1`.

To read/write the following sequence has to be performed:

1. Set SPI FIFO in normal operation by setting `SPI_CTRL_REG[SPI_FIFO_RESET] = 0`.
2. Enable SPI TX path by setting `SPI_CTRL_REG[SPI_TX_EN] = 1`.
3. Enable SPI RX path by setting `SPI_CTRL_REG[SPI_RX_EN] = 1`.
4. Enable the SPI controller by setting `SPI_CTRL_REG[SPI_EN] = 1`.
5. Write the first data byte directly to TX buffer by programming the `SPI_TXBUFFER_FORCE_L_REG[SPI_TXBUFFER_FORCE_L]`.
6. Write the rest of the data to TX FIFO by programming `SPI_FIFO_WRITE_REG[SPI_FIFO_WRITE]`. Write access is permitted only if `SPI_FIFO_STATUS_REG[SPI_TX_FIFO_FULL] = 0`.
7. Read from RX FIFO by programming `SPI_FIFO_READ_REG[SPI_FIFO_READ]`. Read is permitted only if `SPI_FIFO_STATUS_REG[SPI_RX_FIFO_EMPTY] = 0`.

## 16 Quadrature Decoder

### 16.1 Introduction

The DA14530 has an integrated Quadrature decoder that can automatically decode the signals for the X, Y, and Z axes of a HID input device, reporting step count and direction. It can also be programmed to simply count rising/falling edges on any of the channel pairs. This block can be used to wake up the chip as soon as there is a movement from the connected external device. The block diagram of the quadrature decoder is presented in [Figure 42](#).

#### Features

- Three 16-bit signed counters that provide the step count and direction on each of the axes (X, Y, and Z) and one 8-bit counter counting the overall edges from all the three counters
- Programmable system clock sampling at a maximum of 16 MHz
- APB interface for control and programming
- Programmable source from the GPIOs
- Digital filter on the channel inputs to avoid spikes

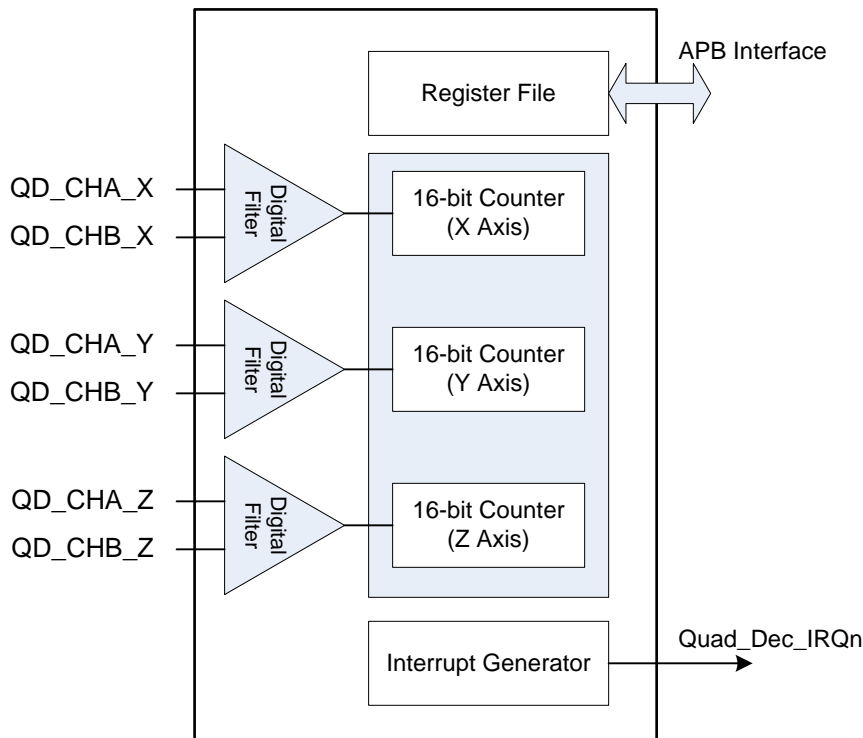

Figure 42: Quadrature Decoder Block Diagram

### 16.2 Architecture

Channels are expected to provide a pulse train with 90 degrees rotation as displayed in [Figure 43](#) and [Figure 44](#).

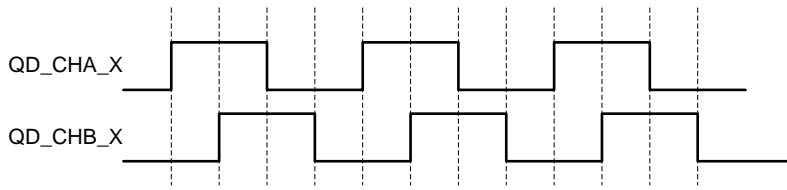

Figure 43: Moving Forward on Axis X

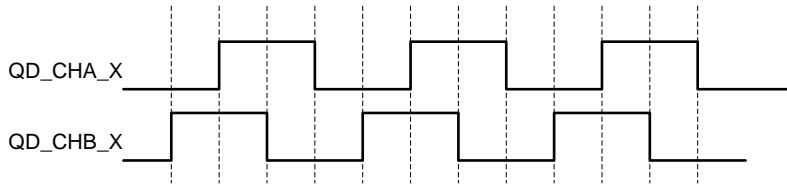

Figure 44: Moving Backwards on Axis X

Depending on whether channel A or channel B is leading in phase, the quadrature decoding block calculates the direction on the related axis. Furthermore, the signed counter value represents the number of steps moved.

Users can choose which GPIOs to use for the channels by programming the QDEC\_CTRL2\_REG register. The block supports two modes of operation: quadrature counting and edges counting. The quadrature counting mode reads the patterns of successive pulses as in Figure 43 and Figure 44, while the edges counting mode simply counts all positive and negative edges on any of the two channels of a pair.

**NOTE**  
If two edges happen at the same time, the counter will only count one.

The digital filter eliminates the spikes shorter than three clock periods. It is followed by an edge detection circuitry and they are shown in Figure 45.

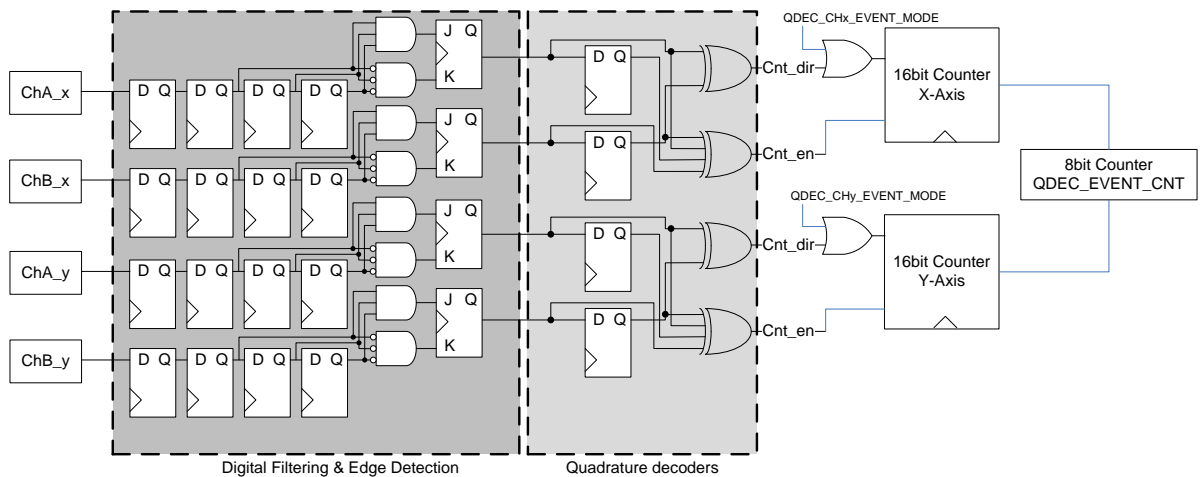

Figure 45: Digital Filtering and Edge Detection Circuit

A counter for its dedicated axis holds the movement events of the channels. When a channel is disabled, the counter is reset. The counters are accessible via the APB bus.

The QDEC\_EVENT\_CNT gathers all edges on all channels regardless of the mode of operation. If two edges happen at the same time, this counter will only be increased by one.

The quadrature decoder operates on the system clock. The QDEC\_CLOCKDIV register defines the number of clock cycles during which the decoding logic samples the data on the channel inputs. The division is automatically disabled when the lp\_clk is used as the system clock.

### 16.3 Programming

To program the quadrature decoder for actual quadrature counting or edge counting, follow the simple sequence of steps below:

1. Configure the clock frequency by configuring the QDEC\_CLOCKDIV register. The value in this register will be dividing the sys\_clk. However, if sys\_clk = lp\_clk, this divider is completely bypassed.
2. Define which pin pairs represent the different channels for the X, Y, and Z axes or the GPIOs from which the edges are counted. Configure such information at QDEC\_CHX\_PORT\_SEL, QDEC\_CHY\_PORT\_SEL, and QDEC\_CHZ\_PORT\_SEL registers.
3. Configure the interrupt threshold upon which an interrupt will be generated at QDEC\_CTRL\_REG[QDEC\_IRQ\_THRES]. Note that the interrupt threshold is based on the value of QDEC\_EVENT\_CNT\_REG which keeps on counting after the interrupt is generated.
4. Define the mode of operation by configuring the respective QDEC\_CHx\_EVENT\_MODE field in the QDEC\_CTRL2\_REG.
5. Enable the clock of the block by writing at CLK\_PER\_REG[QUAD\_ENABLE].
6. Wait for the interrupt and then read X, Y, and Z values at QDEC\_XCNT\_REG, QDEC\_YCNT\_REG, and QDEC\_ZCNT\_REG (in the quadrature counting case) or the QDEC\_EVENT\_CNT\_REG (in the edges counting case).
7. Clear the interrupt (by writing at QDEC\_CTRL\_REG[QDEC\_IRQ\_STATUS]) and the edge counter (by writing at QDEC\_CTRL\_REG[QDEC\_EVENT\_CNT\_CLR] if needed).

## 17 Clockless Wakeup Controller

### 17.1 Introduction

The Clockless Wakeup Controller implements a circuit that enables the RC32K clock which in turn triggers the HW Startup FSM to allow the system to be woken up by an external event (a GPIO toggle). This controller is only used when the system is in hibernation mode, that is, when all clocks are stopped.

#### Features

- Wake up the system from specific GPIOs (P0\_1, P0\_2, P0\_3, P0\_4, and P0\_5)
- Configurable polarity of the GPIO signals (single configuration for all GPIOs)
- Special RC filtered inputs feeding the wakeup control circuit (Type B pads)
- Always powered

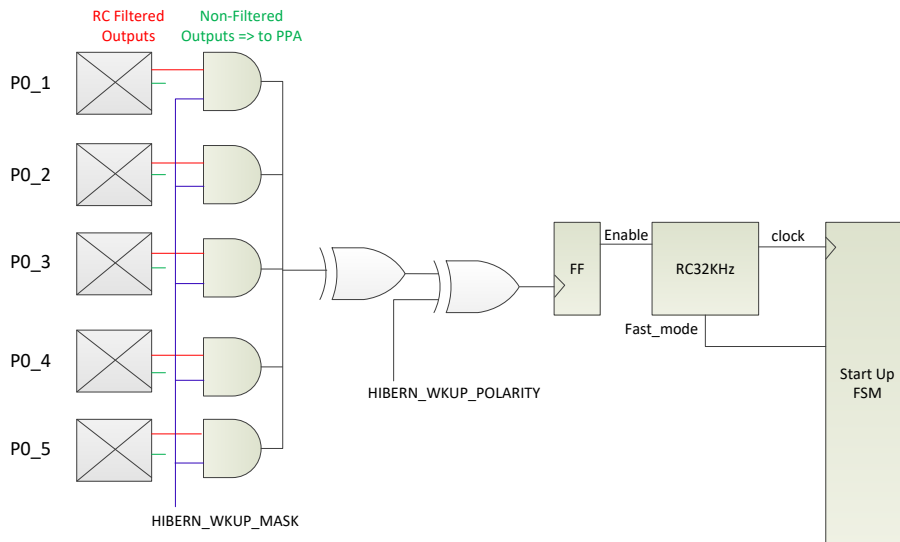

Figure 46: Clockless Wakeup Controller Circuit

### 17.2 Architecture

The Clockless Wakeup Controller automatically enables the RC32K oscillator when a toggle is identified in one of the five specific GPIOs (P0\_1, P0\_2, P0\_3, P0\_4, and P0\_5). These GPIO signals are connected to the Type B pads, which provide two outputs to the digital domain. One output goes through a Schmitt trigger and the other one goes through an RC filter with a cutoff frequency of 100 kHz and a Schmitt trigger. The output going through the RC filter and a Schmitt trigger feeds the clockless wakeup controller circuitry. Hence, any spikes larger than 100 kHz will be filtered out without waking up the system.

The triggering GPIO can be defined by means of a masking register. If no GPIO is masked out, any toggle in any of these GPIOs will create an edge which serves as a clock for a Flip-Flop to lock and enable the oscillator. The polarity of the edge is also programmable, but it is common for the GPIOs and not a dedicated bit per GPIO.

Note that, if two opposite edges occur exactly at the same time on two GPIOs that are allowed to wake up the system, the XOR output will not change its value and no wake up occurs. However, even if the GPIO signal events have a couple of ns difference, the circuit will still understand it and the clock will be started.

### 17.3 Programming

To program the clockless wakeup controller before setting the system into hibernation mode, follow the simple sequence of steps below:

1. Define which pins are allowed to wake up the system from hibernation by configuring the HIBERN\_CTRL\_REG[HIBERN\_WKUP\_MASK].
2. Define the polarity of the waking up events at HIBERN\_CTRL\_REG[HIBERN\_WKUP\_POLARITY]. This should be done by reading the value of the unmasked GPIOs and programming the polarity register with their XOR'ed state.
3. Enable the hibernation mode by programming the HIBERN\_CTRL\_REG[HIBERNATION\_ENABLE] bit field. Note that this action stops all clocks when the system drops to sleep.
4. Allow RAM to be retained by programming the RAM\_PWR\_CTRL\_REG accordingly.
5. Define where address 0 is to be mapped at SYS\_CTRL\_REG[REMAP\_ADR0] so that the CPU can execute code right after waking up. If RAM is retained, REMAP\_ADR0 should point to 0x2 or 0x3.
6. Clear RESET\_STAT\_REG. Clear this register means that the system wakes up from the hibernation mode.
7. Put the system to sleep by executing the WFI command with the SCR bit set.

## 18 Clocked Wakeup Controller

### 18.1 Introduction

The Clocked Wakeup Controller can be programmed to wake up the DA14530 from deep sleep mode and extended sleep mode upon a pre-programmed number of GPIO events on a maximum of two pins in parallel. This wakeup controller resides in the PD\_SLP power domain and operates on the LP\_CLK.

The block diagram illustrating the wakeup function is shown in [Figure 47](#).

#### Features

- Monitors GPIO state changes
- Implements debouncing time from 0 ms up to 63 ms on two GPIOs in parallel
- Accumulates external events and compares the number to a programmed value
- Generates an interrupt to the CPU's WIC

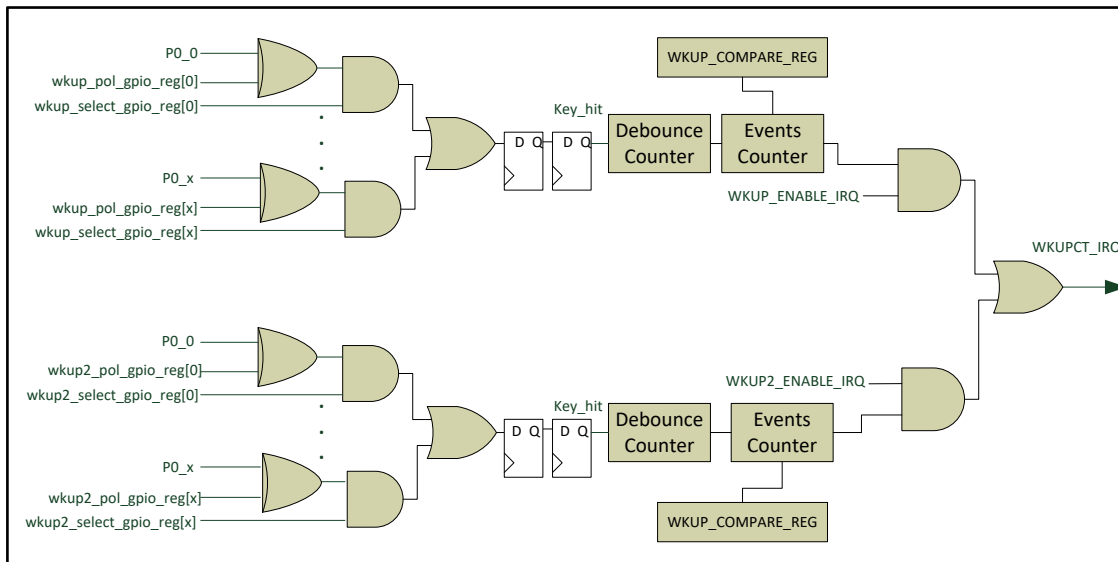
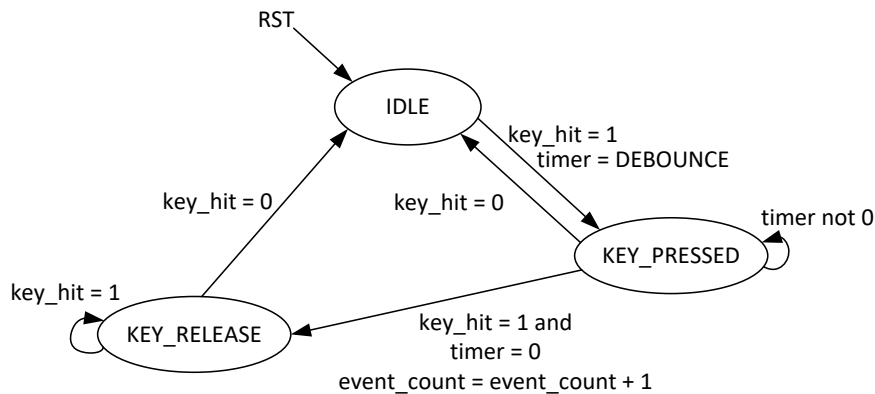

Figure 47: Clocked Wakeup Controller Block Diagram

### 18.2 Architecture

The controller comprises two identical circuits that implement the edge detection, debouncing, and event counting before generating a wakeup interrupt towards the CPU.

A LOW to HIGH level transition on the selected input port sets internal signal "key\_hit" to 1, while  $WKUP\_POL\_GPIO\_REG[y] = 0$ . This signal triggers the event counter state machine as shown in [Figure 48](#). The debounce counter is loaded with the value of  $WKUP\_CTRL\_REG[WKUP\_DEB\_VALUE]$ . The timer counts down every 1 ms. The signal state is constantly monitored. If the debounce counter reaches 0, it means that the key\_hit signal state has been stable over the amount of clock cycles counted by the debounce counter.



**Figure 48: Event Counter State Machine for the Wakeup Interrupt Generator**

The event counter is edge sensitive. After an active edge is detected, a reverse edge must be detected first before the event counter goes back to the IDLE state and from there starts waiting for a new active edge.

If the event counter is equal to the value set in the WKUP\_COMPARE\_REG register, the counter will be reset and an interrupt will be generated, if the interrupt generation has been enabled by WKUP\_ENABLE\_IRQ and WKUP2\_ENABLE\_IRQ in the WKUP\_CTRL\_REG.

**NOTE**

There is only one register for both circuits that contains the number of events before an interrupt is issued.

The interrupt can be cleared by writing a value to the register WKUP\_RESET\_IRQ\_REG. The event counter can be reset by writing a value to the register WKUP\_RESET\_CNTR\_REG. The value of the event counter can be read at any time by reading register WKUP\_COUNTER\_REG.

Any of the GPIO inputs can be selected to generate an event by programming the corresponding WKUP/WKUP2\_SELECT\_GPIO\_REG register. When both WKUP/WKUP2\_SELECT\_GPIO\_REG registers are configured to generate a wakeup interrupt, a toggle on any GPIO will wake up the system.

The input signal edge can be selected by programming the WKUP/WKUP2\_POL\_GPIO\_REG registers.

**NOTE**

A minimum of 2 low power clocks pulse is required on a GPIO in order to be correctly identified as a wake up edge trigger

### 18.3 Programming

To configure the clocked wakeup controller, follow the simple sequence of steps below:

1. Define the polarity of the triggering GPIOs at WKUP/WKUP2\_POL\_GPIO\_REG.
2. Configure the debouncing counters by programming WKUP\_CTRL\_REG[WKUP\_DEB\_VALUE] with the amount of time (ms) during which the signal should be re-sampled before its state is decided. Note that there is a single bit field for both debouncing counters.
3. Define the number of events that are needed to trigger the wakeup interrupt by programming the WKUP\_COMPARE\_REG. Note there is only one register for both circuits.
4. Allow the interrupt generation by configuring the WKUP\_ENABLE\_IRQ and WKUP2\_ENABLE\_IRQ bit fields, respectively, in the WKUP\_CTRL\_REG.
5. Define which GPIOs are allowed to trigger a wakeup event at WKUP/WKUP2\_SELECT\_GPIO\_REG.



6. Set the system to deep sleep mode or extended sleep mode by executing the WFI command with the SCR bit set.

## 19 Timer 0

### 19.1 Introduction

Timer 0 is a 16-bit general purpose software programmable timer, which has the ability of generating Pulse Width Modulated (PWM) signals PWM0 and PWM1. It also generates the SWTIM\_IRQ interrupt to the Arm Cortex-M0+. It can be configured in various modes regarding output frequency, duty cycle, and the modulation of the PWM signals. Figure 49 shows the block diagram of Timer 0.

#### Features

- 16-bit general purpose timer
- Ability to generate two PWM signals (PWM0 and PWM1)
- Programmable output frequency (f) with N = 0 to (2<sup>16</sup>-1) and M = 0 to (2<sup>16</sup>-1)

$$f = \frac{(16, 8, 4, 2 \text{ MHz or } 32 \text{ kHz})}{(M + 1) + (N + 1)}$$

- Programmable duty cycle (δ):

$$\delta = \frac{M + 1}{(M + 1) + (N + 1)} \times 100 \%$$

- Separately programmable interrupt timer:

$$T = \frac{(16, 8, 4, 2 \text{ MHz or } 32 \text{ kHz})}{(ON + 1)}$$

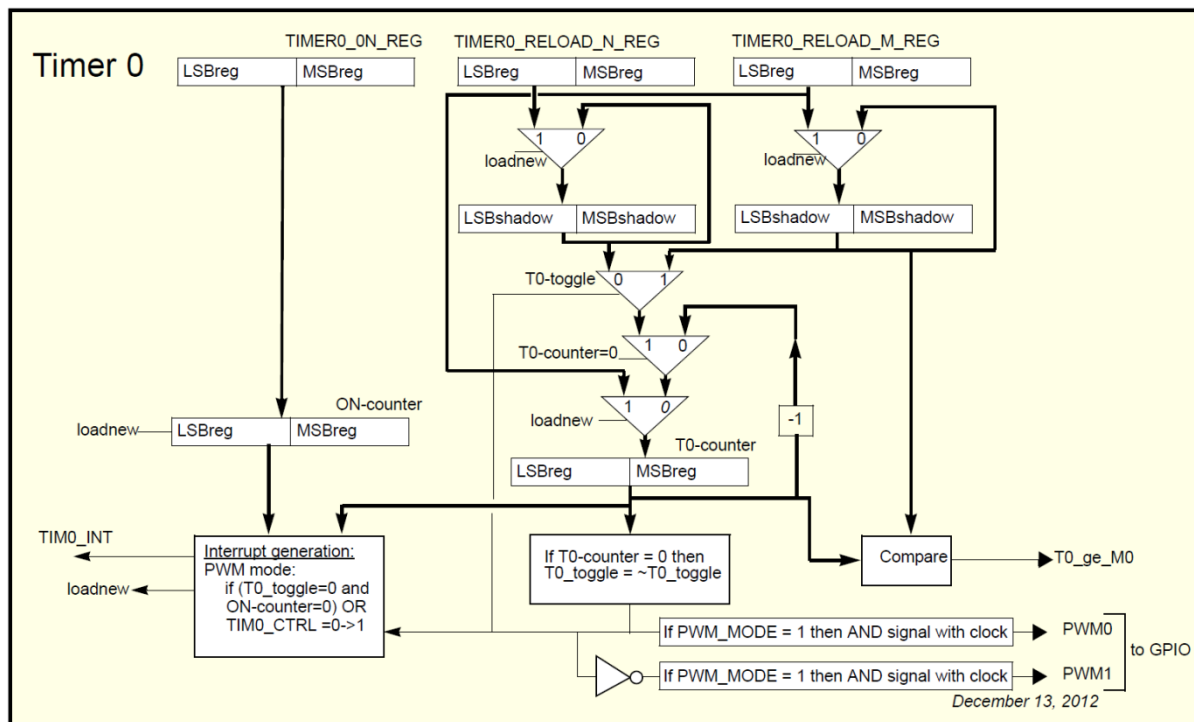

Figure 49: Timer 0 Block Diagram

### 19.2 Architecture

The 16-bit Timer 0 consists of two counters, that is, T0-counter and ON-counter, and three registers, that is, TIMER0\_RELOAD\_M\_REG, TIMER0\_RELOAD\_N\_REG, and TIMER0\_ON\_REG. Upon reset, the counter and register values are 0x0000. Timer 0 generates a PWM signal PWM0, of which

the frequency and duty cycle are determined by the contents of the `TIMER0_RELOAD_N_REG` and the `TIMER0_RELOAD_M_REG` registers. The `PWM1` signal is the inverted version of `PWM0`.

Timer 0 can run at five different clocks: 16 MHz, 8 MHz, 4 MHz, 2 MHz, or 32 kHz. The 32 kHz clock is selected by default with bit `TIM0_CLK_SEL` in the `TIMER0_CTRL_REG` register. This slow clock has no enabling bit. The other four options can be selected by setting the `TIM0_CLK_SEL` bit and the `TMR_ENABLE` bit in the `CLK_PER_REG` (by default the `TMR_ENABLE` bit is disabled). This register also controls the four higher clock frequency on which Timer 0 runs via the `TMR_DIV` bits. An extra clock divider is available and can be activated via bit `TIM0_CLK_DIV` of the timer control register `TIMER0_CTRL_REG`. This clock divider is only used for the ON-counter and always divides the clock for the ON-counter by 10.

**NOTE**

If the LP clock is selected as system clock, the `CLK_AMBA_REG[HCLK]` bit field should always be 0 to ensure the proper operation of the timer.

Timer 0 operates in PWM mode. The signals `PWM0` and `PWM1` can be mapped to any GPIOs.

**Timer 0 PWM Mode**

If bit `TIM0_CTRL` in the `TIMER0_CTRL_REG` is set, Timer 0 will start running. `SWTIM_IRQ` will be generated and the T0-counter will load its start value from the `TIMER0_RELOAD_M_REG` register and will decrement on each clock cycle. The ON-counter also loads its start value from the `TIMER0_ON_REG` register and decrements with the selected clock.

When the T0-counter reaches zero, the internal signal T0-toggle will be toggled to select the `TIMER0_RELOAD_N_REG` whose value will be loaded in the T0-counter. Each time the T0-counter reaches zero, it will alternately be reloaded with the values of the M0- and N0-shadow registers. `PWM0` will be high when the M0-value decrements and low when the N0-value decrements. For `PWM1` the opposite is applicable since it is inverted. If bit `PWM_MODE` in the `TIMER0_CTRL_REG` register is set, the PWM signals are not HIGH during the "high time" but output a clock in that stage. The frequency is based on the clock settings defined in the `CLK_PER_REG` register (also when the 32-kHz clock is used), but the selected clock frequency is divided by two to get a 50 % duty cycle.

If the ON-counter reaches zero, it will remain zero until the T0-counter also reaches zero, while decrementing the value loaded from the `TIMER0_RELOAD_N_REG` register (`PWM0` is low). The counter will then generate an interrupt (`SWTIM_IRQ`). The ON-counter will be reloaded with the value of the `TIMER0_ON_REG` register. The T0-counter as well as the M0-shadow register will be loaded with the value of the `TIMER0_RELOAD_M_REG` register. At the same time, the N0-shadow register will be loaded with the value of `TIMER0_RELOAD_N_REG` register. Both counters will be decremented on the next clock again and the sequence will be repeated.

**NOTE**

It is possible to generate interrupts at a high rate by selecting a high clock frequency and low counter values. This could result in missed interrupt events.

During the time when the ON-counter is non-zero, new values for the ON-register, M0-register, and N0-register can be written, but they are not used by the T0-counter until a full cycle is finished. More specifically, the newly written values in the `TIMER0_RELOAD_M_REG` and `TIMER0_RELOAD_N_REG` registers are only stored into the shadow registers when the ON-counter and the T0-counter have both reached zero and the T0-counter is decrementing the value loaded from the `TIMER0_RELOAD_N_REG` register (Figure 50).

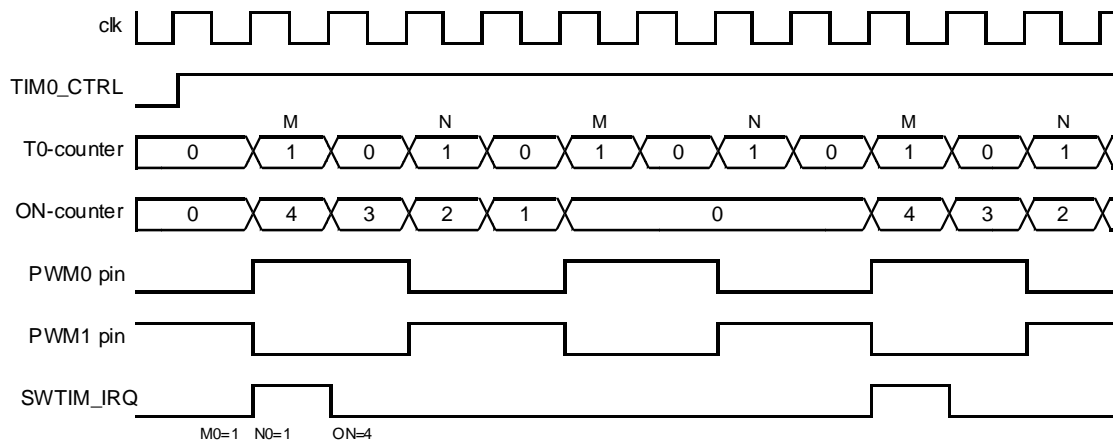

TIM0580-01

**Figure 50: Timer 0 PWM Mode**

At start-up both counters and the PWM0 signal are LOW, so at start-up an interrupt is also generated. If Timer 0 is disabled, all flip-flops, counters, and outputs are in reset state except the ON-register, the `TIMER0_RELOAD_N_REG` register, and the `TIMER0_RELOAD_M_REG` register.

The timer input registers, that is, ON-register, `TIMER0_RELOAD_N_REG`, and `TIMER0_RELOAD_M_REG` can be written, and the counter registers ON-counter and T0-counter can be read. When reading from the address of the ON-register, the value of the ON-counter is returned. Reading from the address of either the `TIMER0_RELOAD_N_REG` or the `TIMER0_RELOAD_M_REG` register returns the value of the T0-counter.

It is possible to freeze Timer 0 with bit `FRZ_SWTIM` of the register `SET_FREEZE_REG`. When the timer is frozen, the timer counters are not decremented. This will freeze all the timer registers at their last value. The timer will continue its operation again when bit `FRZ_SWTIM` is cleared via register `RESET_FREEZE_REG`.

### 19.3 Programming

When LP clock is selected as system clock, `CLK_AMBA_REG[HCLK_DIV]` should be set to 0.

When LP clock is selected as Timer clock, `CLK_PER_REG[TMR_DIV]` should be set to 0

#### 19.3.1 Timer Functionality

Timer 0 supports the functionality of a timer for generating interrupts after specific time intervals. To configure the timer operation, follow the steps below:

1. Select the timer clock by programming `TIMER0_CTRL_REG[TIM0_CLK_SEL]`. The system or the LP clock can be selected using this option.
2. Select the clock division scaler by programming `CLK_PER_REG[TMR_DIV]`. Note that this setting only applies to the system clock.
3. Define whether Timer 0 will use the clock frequency as is or divided by 10 by programming `TIMER0_CLK_REG[TIM0_CLK_DIV]`.
4. Enable Timer 0 clock by programming `CLK_PER_REG[TMR_ENABLE]`.
5. For 16-bit counting, program `TIMER0_ON_REG` with the expired time in timer 0 clock cycles. `TIMER0_RELOAD_M_REG` and `TIMER0_RELOAD_N_REG` must be set to 0.
6. For 17-bit counting, load 65535 to `TIMER0_RELOAD_M_REG` and the rest to `TIMER0_RELOAD_N_REG`. `TIMER0_ON_REG` must be set to 0.
7. Enable Timer 0 by programming `TIMER0_CTRL_REG[TIM0_CTRL]`.

### 19.3.2 PWM Generation

Timer 0 also supports PWM generation. To configure the PWM generation functionality, follow the steps below:

1. Select the timer clock by programming `TIMER0_CTRL_REG[TIM0_CLK_SEL]`. The system or the LP clock can be selected by this option.
2. Select the clock division scaler by programming `CLK_PER_REG[TMR_DIV]`. Note that this setting only applies to the system clock.
3. Select the PWM mode by programming the `TIMER0_CTRL_REG[PWM_MODE]`. There are two modes supported. In the first one, the PWM signals are '1' during high time. In the second one, the PWM signals send out the (fast) clock divided by two during high time, so the clock frequency will be in the range of 1 to 8 MHz.
4. Enable Timer 0 clock by programming `CLK_PER_REG[TMR_ENABLE]`.
5. Load the "high" value of the duty cycle in `TIMER0_RELOAD_M_REG` and the "low" value of the duty cycle in `TIMER0_RELOAD_N_REG`.
6. Set the desired GPIOs in `PWM0/PWM1` and output mode.
7. Enable Timer 0 by programming `TIMER0_CTRL_REG[TIM0_CTRL]`.

## 20 Timer 1

### 20.1 Introduction

Timer 1 is an 11-bit timer that can count up or down. It supports a free-running mode with an interrupt generated when zero is reached (also by wrapping around). It can be configured to use the system clock (`sys_clk`) or the LP clock (`lp_clk`) as the clock source. It supports capturing events on two GPIO channels when the number of clock cycles between these events is known. It can also generate an interrupt after a programmable number of clock cycles after an event. [Figure 51](#) shows the block diagram of Timer 1.

#### Features

- 11-bit up/down counter with free running mode
- Selectable system or LP clock as source
- Two channels for capture input triggered by GPIOs
- Capture capability from two GPIO events with programmable polarity
- Programmable number of events between the two GPIOs for capturing
- Timer 1 or RTC snapshot on capture events
- Interrupt generation

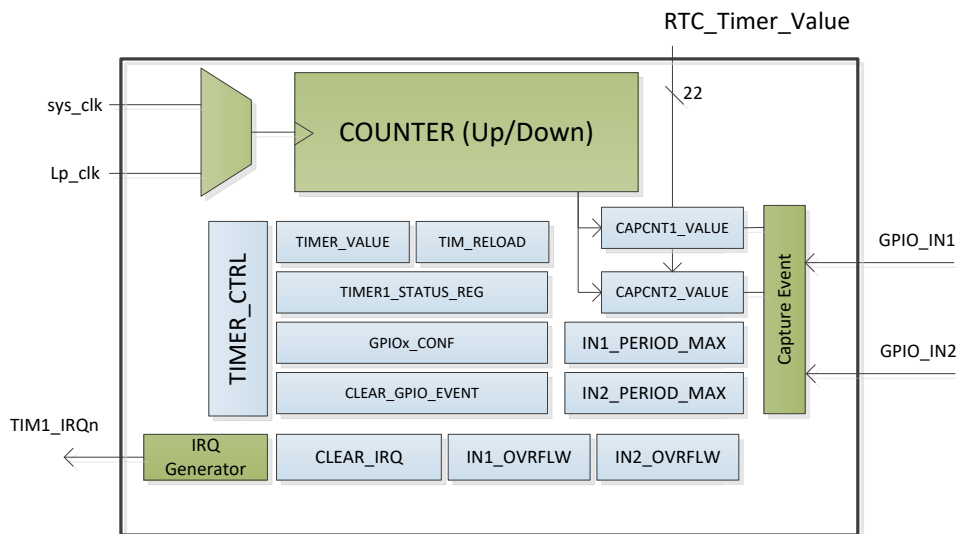

Figure 51: Timer 1 Block Diagram

## 20.2 Architecture

Timer 1 is placed in the PD\_TIM power domain which can be kept powered even when the system power domain (containing the CPU) is shut down.

The main operation of Timer 1 is to count up or down, generating an interrupt when it reaches the maximum/minimum value or the threshold that has been programmed as the reload value.

Moreover, Timer 1 comes with a sense block that allows for sensing positive or negative edges on two GPIOs (configurable). The sense block operates in two modes:

- Counting mode:** Timer1 will generate an interrupt upon a configurable amount of edges on a GPIO has been detected. The number of clock cycles was counted between timer start and captured the N - events is stored to CAPCNTx\_VALUE register. When timer detects the first N-events, automatically starts to detect the next N-events until timer is disabled
- Capture mode:** Timer 1 saves a snapshot of either its own counter (11 bits) or the RTC port (22 bits) after an edge on a GPIO has been detected. If there is a pending interrupt, a new snapshot is not saved and the TIMER1\_STATUS\_REG[TIMER1\_INx\_OVRFLW] bit is set. This bit is cleared together with the TIMER1\_STATUS\_REG[TIMER1\_Inx\_EVENT] bit

The same GPIO can be used for both modes.

If Timer 1 is used in the counting mode, it can measure the frequency applied to a GPIO port (see section 20.3.3).

## 20.3 Programming

When LP clock is selected as system clock, CLK\_AMBA\_REG[HCLK\_DIV] should be set to 0.

### 20.3.1 Timer Functionality

Timer 1 supports the functionality of a timer for generating interrupts after specific time intervals. To configure the timer functionality, follow the steps below:

- Select the timer clock by programming TIMER1\_CTRL\_REG[TIMER1\_USE\_SYS\_CLK]. The system or the LP clock can be selected by this option.

#### NOTE

If the LP clock is selected as system clock, the CLK\_AMBA\_REG[HCLK] bit field should always be 0 to ensure the proper operation of the timer.

2. Enable or disable the free run mode by programming `TIMER1_CTRL_REG[TIMER1_FREE_RUN_MODE_EN]`. The free run mode can only be used when Timer 1 counts up.
3. Enable Timer 1 interrupt by programming `TIMER1_CTRL_REG[TIMER1_IRQ_EN]`.
4. Set Timer 1 to count up or down by programming `TIMER1_CTRL_REG[TIMER1_COUNT_DOWN_EN]`.
5. Specify the reload value by programming `TIMER1_CTRL_REG[TIMER1_RELOAD]`.
6. Enable the Timer 1 clock by programming `TIMER1_CTRL_REG[TIMER1_CLK_EN]`.
7. Enable Timer 1 by programming `TIMER1_CTRL_REG[TIMER1_ENABLE]`.

### 20.3.2 Capture Functionality

Timer 1 can capture a snapshot of the value of RTC or Timer1 counts after a GPIO edge is detected. To configure the capture functionality, follow the steps below:

1. Depending on the source of the snapshot value, configure and enable RTC or Timer 1 or both in the capture mode.
2. Set the edge type (rising or falling edge) by programming `TIMER1_CAPTURE_REG[TIMER1_IN1_EVENT_FALL_EN]` or `TIMER1_CAPTURE_REG[TIMER1_IN2_EVENT_FALL_EN]`, depending on the channel that is used.
3. Set the timer in capture mode by setting `TIMER1_CAPTURE_REG[TIMER1_IN1_COUNT_EN]=0` or `TIMER1_CAPTURE_REG[TIMER1_IN2_COUNT_EN]=0`, depending on the channel that is used.
4. Enable capture interrupt by setting `TIMER1_CAPTURE_REG[TIMER1_IN1_IRQ_EN] = 1` or `TIMER1_CAPTURE_REG[TIMER1_IN2_IRQ_EN] = 1`, depending on the channel that is used.
5. Set the source of the snapshot value (RTC or Timer 1 count) by setting `TIMER1_CAPTURE_REG[TIMER1_IN1_STAMP_TYPE]` or `TIMER1_CAPTURE_REG[TIMER1_IN2_STAMP_TYPE]`, depending on the channel that is used.
6. Set the GPIO that will be used to trigger the capture by setting `TIMER1_CAPTURE_REG[TIMER1_GPIO1_CONF]` or `TIMER1_CAPTURE_REG[TIMER1_GPIO1_CONF]`, depending on the channel that is used. Note that the values from 1 to 12 define the P0 pins from 0 to 11.
7. When an interrupt is generated, the capture value will be saved in `TIMER1_CAPCNT1_VALUE_REG[TIMER1_CAPCNT1_VALUE]` or `TIMER1_CAPCNT2_VALUE_REG[TIMER1_CAPCNT2_VALUE]`, depending on the channel that is used.
8. Write 1 to `TIMER1_CLR_EVENT_REG[TIMER_CLR_Inx_EVENT]` to clear the event.

### 20.3.3 Frequency Measuring Functionality

Timer 1 can measure the frequency applied to a GPIO port. To configure the frequency measure functionality, follow the steps below:

1. Configure and enable Timer 1 in count up free mode using the system clock.
2. Set Timer 1 in count mode by setting `TIMER1_CAPTURE_REG[TIMER1_IN1_COUNT_EN] = 1` or `TIMER1_CAPTURE_REG[TIMER1_IN2_COUNT_EN] = 1`, depending on the channel that is used.
3. Enable capture interrupt by setting `TIMER1_CAPTURE_REG[TIMER1_IN1_IRQ_EN] = 1` or `TIMER1_CAPTURE_REG[TIMER1_IN2_IRQ_EN] = 1`, depending on the channel that is used.
4. Set the rising edge by programming `TIMER1_CAPTURE_REG[TIMER1_IN1_EVENT_FALL_EN] = 0` or `TIMER1_CAPTURE_REG[TIMER1_IN2_EVENT_FALL_EN] = 0`, depending on the channel that is used.
5. Set the number of periods plus one, in which Timer 1 counts, by setting `TIMER1_CAPTURE_REG[TIMER1_IN1_PERIOD_MAX]` or `TIMER1_CAPTURE_REG[TIMER1_IN2_PERIOD_MAX]`, depending on the channel that is used.

6. Set the GPIO that will be used to trigger the capture by setting `TIMER1_CAPTURE_REG[TIMER1_GPIO1_CONF]` or `TIMER1_CAPTURE_REG[TIMER1_GPIO2_CONF]`, depending on the channel that is used. Note that the values from 1 to 12 define the P0 pins from 0 to 11.
7. After the interrupt is triggered, read the value in `TIMER1_CAPCNT1_VALUE_REG[TIMER1_CAPCNT1_VALUE]` or `TIMER1_CAPCNT2_VALUE_REG[TIMER1_CAPCNT2_VALUE]`, depending on the channel that is used. This value indicates the number of cycles that has passed during the period defined in step 5.
8. To calculate the frequency applied to the GPIO, divide the number of periods (step 5) by the cycles (step 7) and multiply the result with the frequency of Timer 1 clock.
9. Write 1 to `TIMER1_CLR_EVENT_REG[TIMER_CLR_Inx_EVENT]` to clear the event.

## 21 Timer 2

### 21.1 Introduction

Timer 2 is basically a PWM generator. It has six PWM outputs. The block diagram is shown in [Figure 52](#).

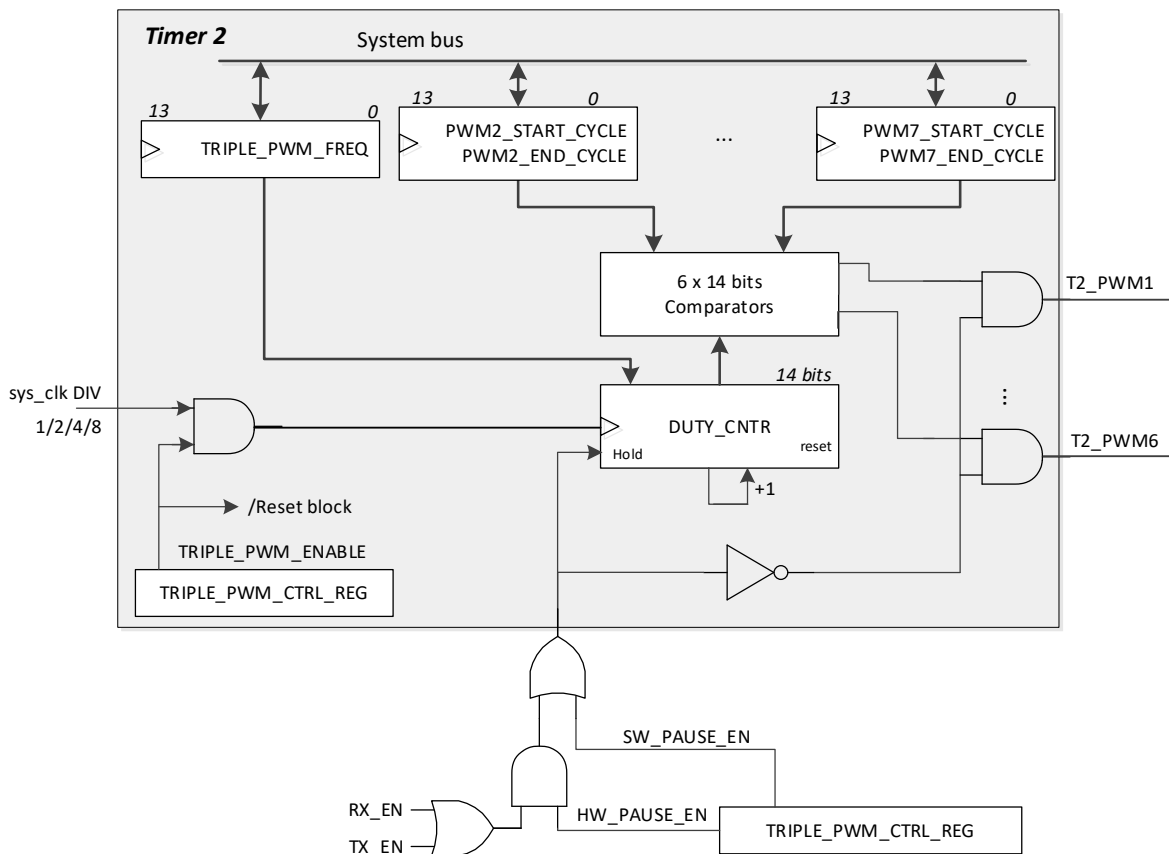

**Figure 52: Timer 2 Block Diagram**

#### Features

- 14-bit general purpose timer
- Ability to generate six PWM signals (PWM2, PWM3, PWM4, PWM5, PWM6, and PWM7,)
- Input clock frequency ( $f_{IN}$ ) with  $N = 1, 2, 4, \text{ or } 8$  and  $\text{sys\_clk} = 16 \text{ MHz or } 32 \text{ kHz}$ :



$$f_{IN} = \frac{sys\_clk}{N}$$

- Programmable output frequency ( $f_{OUT}$ ):

$$f_{OUT} = \left(\frac{f_{IN}}{2}\right) \text{ to } \left(\frac{f_{IN}}{2^{14}-1}\right)$$

- Six outputs with a programmable duty cycle from 0 % to 100 %
- Used for white LED intensity (on/off) control or motor control

## 21.2 Architecture

Timer 2 is clocked with the system clock divided by TMR\_DIV (1, 2, 4, or 8) and can be enabled with TRIPLE\_PWM\_CTRL\_REG[TRIPLE\_PWM\_ENABLE].

TRIPLE\_PWM\_FREQUENCY determines the output frequency of the PWM outputs.

NOTE
There is a single frequency register for all six PWM outputs.

DUTY\_CNTR is an up-counter counting from 0 up to TRIPLE\_PWM\_FREQUENCY.

If DUTY\_CNTR is equal to the value stored in the respective PWMn\_END\_CYCLE register, it resets the PWMn output to 0.

If DUTY\_CNTR is equal to the value stored in the respective PWMn\_START\_CYCLE register, it sets the PWMn output to 1.

Note that the value of PWMn\_END\_CYCLE and PWMn\_START\_CYCLE must be less than or equal to TRIPLE\_PWM\_FREQUENCY.

The Timer 2 is enabled/disabled by programming the TRIPLE\_PWM\_CTRL\_REG[TRIPLE\_PWM\_EN] bit.

The timing diagram of Timer 2 is shown in [Figure 53](#).

### Freeze function

During RF activity it may be desirable to temporarily suppress the PWM switching noise. This can be done by setting TRIPLE\_PWM\_CTRL\_REG[HW\_PAUSE\_EN] = 1. The effect is that whenever there is a transmission or a reception process from the Radio, DUTY\_CNTR is frozen and PWMx output is switched to 0 to disable the selected PWMn. As soon as the Radio is idle, that is, RX\_EN or TX\_EN signals are zero, DUTY\_CNTR resumes counting and finalizes the remaining part of the PWM duty cycle.

TRIPLE\_PWM\_CTRL\_REG[SW\_PAUSE\_EN] can be set to 0 to disable the automatic, hardware driven freeze function of the duty counter and keep the duty cycle constant.

Note that the RX\_EN and TX\_EN signals are not software driven but controlled by the BLE core hardware.

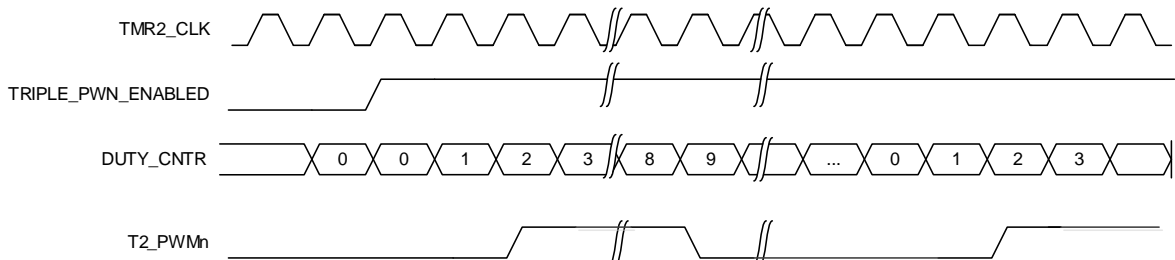

Figure 53: Timer 2 Timing Diagram

### 21.3 Programming

When LP clock is selected as system clock, CLK\_AMBA\_REG[HCLK\_DIV] should be set to 0.

When LP clock is selected as Timer clock, CLK\_PER\_REG[TMR\_DIV] should be set to 0

#### 21.3.1 PWM Generation

Timer 2 only supports PWM generation and does not support a normal, interrupt generating, timer functionality as the previous timers do. To configure the PWM generation functionality, follow the steps below:

1. Select the clock source for Timer 2 by programming TRIPLE\_PWM\_CTRL\_REG[TRIPLE\_PWM\_CLK\_SEL]. System clock or LP clock can be selected. Please note that if the (fast) system clock is selected, the division scaler is the same as the one for Timer 0.
2. Define the GPIOs to which the PWM signals are mapped by programming the respective PID number.
3. Define the frequency of Timer 2 that feeds the PWM waveforms by programming the TRIPLE\_PWM\_FREQUENCY with a value that conforms to the following equation. For example, if Timer 2 clock is 32000 Hz (lp\_clk) and the required frequency for the PWM is 16 kHz, this register should be written with 0x1.

$$\text{Timer2\_clk\_freq\_Hz} / \text{Required\_freq\_Hz} - 1 \tag{4}$$

<b>NOTE</b>
There is a single frequency register for all six PWM outputs.

4. Define the duty cycle of each PWM signal. Program the start and end cycle of the pulse at PWMx\_START\_CYCLE and PWMx\_END\_CYCLE, respectively. The available amount of cycles is depicted in the contents of TRIPLE\_PWM\_FREQUENCY register. For example, if the TRIPLE\_PWM\_FREQUENCY has a value of 0x8 and the START/END\_CYCLE bit fields have a value of 3 and 5, respectively, the PWM signals will rise after three Timer 2 clock cycles and fall after five clock cycles. Every PWM signal has its own register to configure its duty cycle.
5. Enable the PWM signals by programming TRIPLE\_PWM\_CTRL\_REG[TRIPLE\_PWM\_ENABLE] = 1.

#### 21.3.2 Freeze Functionality

There is provision to allow hardware to pause PWM signals while RF is active. This can be done by programming TRIPLE\_PWM\_CTRL\_REG[HW\_PAUSE\_EN] = 1. It can also be done via SW control by programming TRIPLE\_PWM\_CTRL\_REG[SW\_PAUSE\_EN] = 1.

## 22 Watchdog Timer

### 22.1 Introduction

The Watchdog Timer is an 8-bit timer with a sign bit that can be used to detect an unexpected execution sequence caused by a software run-away and can generate a full system reset (WDOG reset) or a Non-Maskable Interrupt (NMI). Figure 54 shows the block diagram of the Watchdog Timer.

#### Features

- 8-bit down counter with a sign bit, clocked with a 10.24 ms clock for a maximum 2.6 s time-out
- Non-Maskable Interrupt (NMI) or WDOG reset
- Optional automatic WDOG reset if NMI handler fails to update the Watchdog register
- Non-maskable Watchdog freeze of the Cortex-M0+ Debug module when the Cortex-M0+ is halted in Debug state. Maskable Watchdog freeze by user program

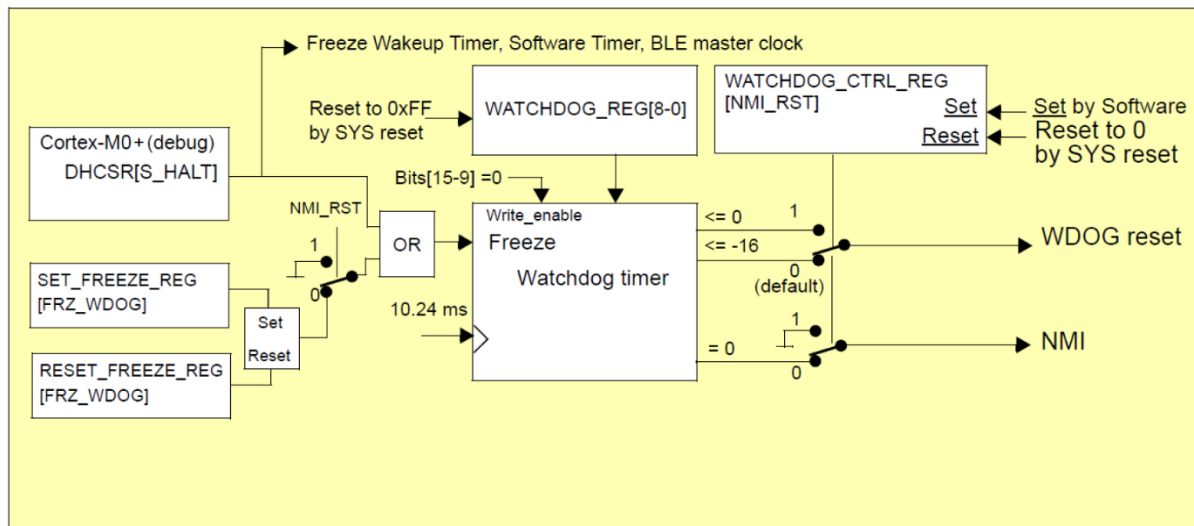

Figure 54: Watchdog Timer Block Diagram

### 22.2 Architecture

The 8-bit watchdog timer is decremented by 1 every 10.24 ms. The timer value can be accessed through the WATCHDOG\_REG register which is set to 255 ( $FF_{16}$ ) at reset. This results in a maximum watchdog time-out of ~2.6 s. During write access, the WATCHDOG\_REG[WDOG\_WEN] bit must be 0. This provides extra filtering for a software run-away by writing ones to all the bits in the WATCHDOG\_REG. If the watchdog timer reaches 0, its value will get a negative value by setting bit 8. The counter sequence becomes 1, 0,  $1FF_{16}$  (-1),  $1FE_{16}$  (-2), till  $1F0_{16}$  (-16).

If WATCHDOG\_CTRL\_REG[NMI\_RST] = 0, the watchdog timer will generate an NMI when it reaches 0 and a WDOG reset when it becomes less or equal to -16 ( $1F0_{16}$ ). The NMI handler must write a value that is larger than -16 to the WATCHDOG\_REG to prevent the generation of a WDOG reset when the watchdog timer reaches the value -16 after  $16 \times 10.24 = 163.8$  ms.

If WATCHDOG\_CTRL\_REG[NMI\_RST] = 1, the watchdog timer generates a WDOG reset when it becomes less than or equal to 0.

The WDOG reset is one of the system (SYS) reset sources and resets almost the whole device, including resetting the WATCHDOG\_REG register to 255. Refer to the [POR, HW, and SW Reset](#) section for an overview of the complete reset circuit and conditions.

For debugging purposes, the Cortex-M0+ Debug module can always freeze the watchdog by setting the DHCSR[DBGKEY | C\_HALT | C\_DEBUGEN] control bits (reflected by the status bit S\_HALT, see

Table 42). This is automatically done by the debugging tool, for example, during step-by-step debugging. Note that this bit also freezes the Wake-up Timer, the Software Timer, and the BLE master clock. For additional information see the `DEBUG_REG[DEBUGS_FREEZE_EN]` mask register. The `C_DEBUGEN` bit cannot be accessed by the user software so that freezing the watchdog is prevented.

In addition to the `S_HALT` bit, the watchdog timer can also be frozen if `NMI_RST = 0` and `SET_FREEZE_REG[FRZ_WDOG]` is set to 1. The watchdog timer resumes counting when `RESET_FREEZE_REG[FRZ_WDOG]` is set to 1. The `WATCHDOG_CTRL_REG[NMI_RST]` bit can only be set by software and will only be reset on a SYS reset. Note that if the system is not remapped, that is, the SysRAM is at address `0x07FC0000`, a watchdog fire will trigger the BootROM code to be executed again.

### 22.3 Programming

To program the Watchdog Timer, follow the simple sequence of steps below:

1. Freeze watchdog by setting the `SET_FREEZE_REG[FRZ_WDOG]` bit (optional).
2. Select NMI and reset events (`WATCHDOG_CTRL_REG[NMI_RST]`).
3. Enable writing of the watchdog timer (`WATCHDOG_REG[WDOG_WEN] = 0`).
4. Write the reload value of the watchdog timer (`WATCHDOG_REG[WDOG_VAL]`, see the register description).
5. Resume watchdog (`RESET_FREEZE_REG[FRZ_WDOG] = 1`), if frozen.

## 23 Temperature Sensor

### 23.1 Introduction

The DA14530 features a built-in temperature sensor.

#### Features

- Temperature range -40°C to 105°C
- Absolute accuracy after one-point calibration +/- 4°C (assuming 25°C reference temperature)
- 25°C single point calibration reference value provided in OTP memory

### 23.2 Architecture

The temperature sensor can be read out via the GP\_ADC.

Figure 55 illustrates the relationship between the actual ambient temperature and the calculated temperature from the GP\_ADC readout, including possible inaccuracies in  $T_{SENSE\_ACC\_OTP}$  (offset) and  $TC_{SENSE}$  (angle).

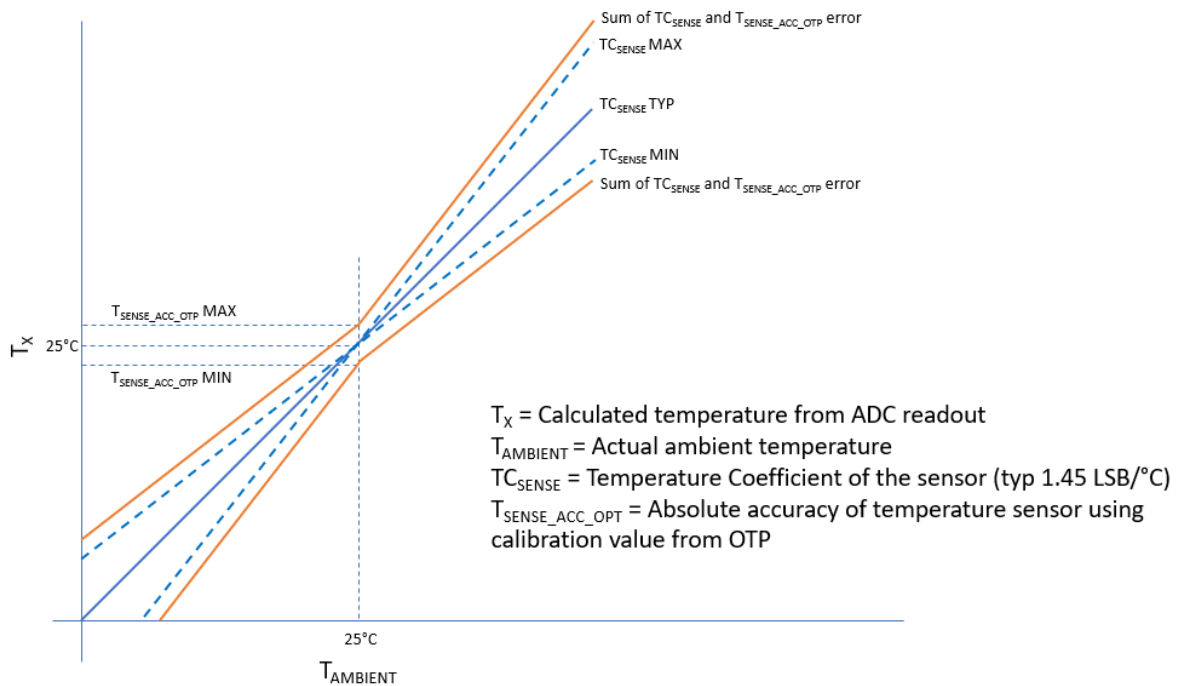

Figure 55: Temperature Sensor Behavior

The recommended formula for single point calibrated temperature reading is as follows:

$$T_x = 25 + (ADC_x - ADC_{OTP\_CAL\_25C}) / (TC_{SENSE} \times 64)$$

Where:

- $T_x$  = calculated single point calibrated die temperature in [°C]
- $ADC_x$  = 16-bit GP\_ADC\_VAL readout (converted to decimal) at temperature  $T_x$
- $ADC_{OTP\_CAL\_25C}$  = 25°C OTP calibration value recorded during production testing (based on the 16-bit readout)
- $TC_{SENSE}$  = temperature coefficient in [LSB/°C], typical value is 1.45 LSB/°C
- 25 = reference base value in [°C]
- 64 = correction for 16-bit to 10-bit ADC values

For uncalibrated temperature sensor measurements,  $ADC_{OTP\_CAL\_25C}$  can be replaced by the default value using the formula below:

$$T_x = 25 + (ADC_x - 30272) / (TC_{SENSE} \times 64)$$

Note that this is not recommended since it can result in large offsets.

NOTE
While measuring and/or calibration, the system's power dissipation should be kept the same, otherwise the measurement is affected by the internal thermal gradient.

### 23.2.1 Programming

There is a certain programming sequence required to read the temperature sensor. There are two reading options available:

1. absolute temperature (single-point calibration)
2. relative temperature

#### 23.2.1.1 Absolute Temperature

A calibration value at 25°C is stored in OTP for absolute temperature measurements. When the calibration value from OTP is used, the default GP\_ADC offset calibration settings should be used.

- To enable OTP in normal read mode:
  - CLK\_AMBA\_REG[OTP\_ENABLE] = 1
  - OTPC\_MODE\_REG[OTPC\_MODE\_MODE] = 2
- To read the calibration value at 25°C:
  - Read  $ADC_{OTP\_CAL\_25C}$ : the content of  $ADC_{OTP\_CAL\_25C}$  is at the address 0x7F87F28 of the OTP
- To disable OTP:
  - OTPC\_MODE\_REG[OTPC\_MODE\_MODE] = 0
  - CLK\_AMBA\_REG[OTP\_ENABLE] = 0
- To read back the offset calibration:
  - $Offp = GP\_ADC\_OFFP\_REG[GP\_ADC\_OFFP]$
  - $Offn = GP\_ADC\_OFFN\_REG[GP\_ADC\_OFFN]$

(Store the data if the original values are need later for the application)

- To overwrite the defaults (the settings during factory calibration) with the ADC offset values
  - $GP\_ADC\_OFFP\_REG[GP\_ADC\_OFFP] = 200$
  - $GP\_ADC\_OFFN\_REG[GP\_ADC\_OFFN] = 200$
- To enable the temperature sensor:

- GP\_ADC\_CTRL\_REG[DIE\_TEMP\_EN] = 1
- Wait 25  $\mu$ s for the temperature sensor to start up
- To set the advised ADC settings:
  - GP\_ADC\_TRIM\_REG[GP\_ADC\_LDO\_LEVEL] = 4
  - GP\_ADC\_CTRL\_REG[GP\_ADC\_CHOP] = 1
  - GP\_ADC\_CTRL\_REG[GP\_ADC\_SE] = 1
  - GP\_ADC\_CTRL\_REG[GP\_ADC\_EN] = 1
  - GP\_ADC\_CTRL2\_REG[GP\_ADC\_I20U] = 1
  - GP\_ADC\_SEL\_REG[GP\_ADC\_SEL\_P] = 4
  - GP\_ADC\_CTRL2\_REG[GP\_ADC\_STORE\_DEL] = 0
- To set sample time and averaging of the ADC sampling
  - GP\_ADC\_CTRL2\_REG[GP\_ADC\_SMPL\_TIME] = F
  - GP\_ADC\_CTRL2\_REG[GP\_ADC\_CONV\_NRS] = 6
- To perform ADC conversion:
  - GP\_ADC\_CTRL\_REG[GP\_ADC\_START] = 1
- To wait for the conversion to finish, read the register
  - GP\_ADC\_RESULT\_REG[GP\_ADC\_VAL]
- To write back the original offset values
  - GP\_ADC\_OFFP\_REG[GP\_ADC\_OFFP] = Offp
  - GP\_ADC\_OFFN\_REG[GP\_ADC\_OFFN] = Offn

(Restore the original data if need by the application)

### 23.2.1.2 Relative Temperature

For relative temperature measurements, the single-point calibration is not needed. The programming sequence is presented below.

- To enable GP\_ADC:
  - GP\_ADC\_CTRL\_REG[DIE\_TEMP\_EN] = 1
- Wait 25  $\mu$ s for the temperature sensor to start up
- To set the advised ADC settings:
  - GP\_ADC\_TRIM\_REG[GP\_ADC\_LDO\_LEVEL] = 4
  - GP\_ADC\_CTRL\_REG[GP\_ADC\_CHOP] = 1
  - GP\_ADC\_CTRL\_REG[GP\_ADC\_SE] = 1
  - GP\_ADC\_CTRL\_REG[GP\_ADC\_EN] = 1
  - GP\_ADC\_CTRL2\_REG[GP\_ADC\_I20U] = 1
  - GP\_ADC\_SEL\_REG[GP\_ADC\_SEL\_P] = 4
  - GP\_ADC\_CTRL2\_REG[GP\_ADC\_STORE\_DEL] = 0
- To set sample time and averaging of the ADC sampling
  - GP\_ADC\_CTRL2\_REG[GP\_ADC\_SMPL\_TIME] = F
  - GP\_ADC\_CTRL2\_REG[GP\_ADC\_CONV\_NRS] = 6
- To perform ADC conversion:
  - GP\_ADC\_CTRL\_REG[GP\_ADC\_START] = 1
- To wait for the conversion to finish, read the register
  - GP\_ADC\_RESULT\_REG[GP\_ADC\_VAL]

## 24 Keyboard Controller

### 24.1 Introduction

The Keyboard controller can be used for debouncing the incoming GPIO signals when implementing a keyboard scanning engine. It generates an interrupt to the CPU (KEYBR\_IRQ).

In parallel, five extra interrupt lines can be triggered by a state change on up to 12 selectable GPIOs (GPIO\_IRQx).

#### Features

- Monitors the 12 available GPIOs (6 in the WLCSP17 package and 12 in the FCGQFN24 package)
- Generates a keyboard interrupt on key press or key release
- Implements debouncing time from 0 up to 63 ms.
- Supports five separate interrupt generation lines from GPIO toggling

The block diagram of the Keyboard Controller is presented in the [Figure 56](#).

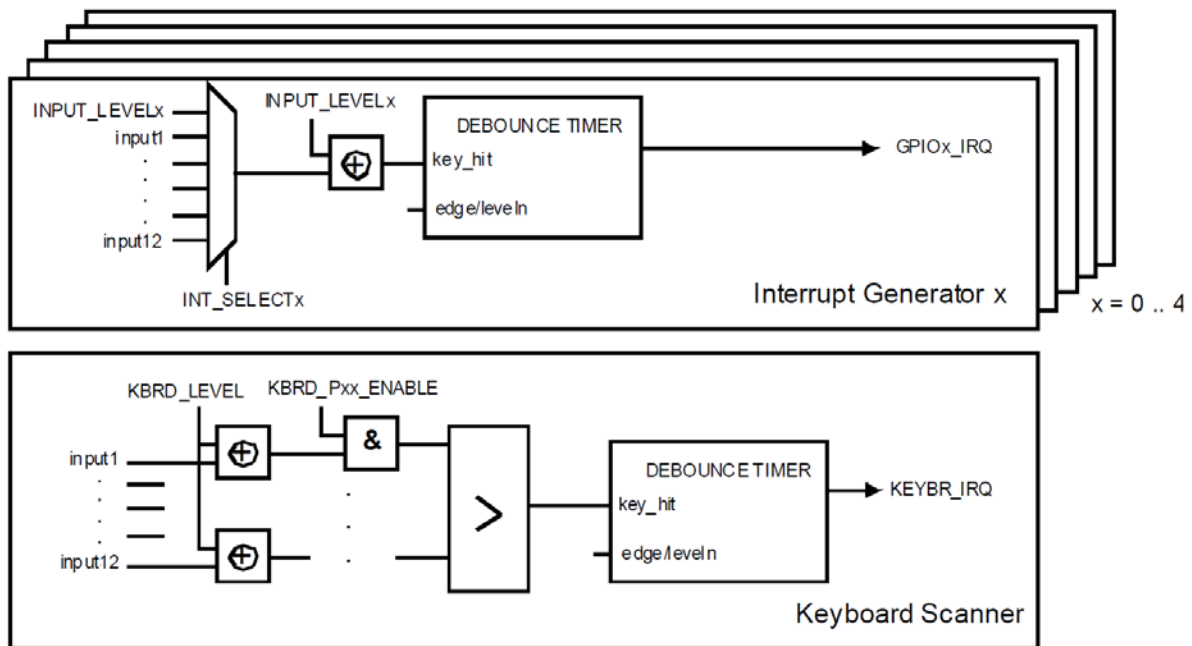

Figure 56: Keyboard Controller Block Diagram

### 24.2 Architecture

#### 24.2.1 Keyboard Scanner

A HIGH-to-LOW transition on one of the GPIO inputs sets the internal signal "key\_hit" to 1, while  $KBRD\_IRQ\_IN\_SELO\_REG[KBRD\_LEVEL] = 0$  and  $KBRD\_IRQ\_IN\_SELx\_REG[KBRD\_Pyy\_EN] = 1$ . This signal triggers the state machine of the keyboard interface shown in [Figure 57](#). The debounce timer is loaded with the value of  $GPIO\_DEBOUNCE\_REG[DEB\_VALUE]$ . The timer counts down every 1 ms. When the timer reaches 0 and the "key\_hit" signal is still 1, the timer is loaded with the value of  $KBRD\_IRQ\_IN\_SELO\_REG[KEY\_REPEAT]$ , generating a repeating sequence of interrupts every time when the timer reaches 0.

When the key is released (key\_hit = 0) and the bit KBRD\_REL (key release) is set to 1, a new debounce sequence is started and a KEYBR\_IRQ interrupt is generated after the debounce time.



The debounce timer can be disabled with `GPIO_DEBOUNCE_REG[DEB_ENABLE_KBRD] = 0`. The key repeat function can be disabled by setting `KEY_REPEAT` to 0.

The level for generating an interrupt is programmable via bit `KBRD_IRQ_IN_SELO_REG[KBRD_LEVEL]`. The key release function can be disabled by setting bit `KBRD_IRQ_IN_SELO_REG[KBRD_REL]` to 0. The inputs for the keyboard interface can be selected by setting the corresponding bits `KBRD_IRQ_IN_SELO_REG[KBRD_Pxx_EN]` to 1.

The keyboard interrupt service routine can distinguish which input has caused the interrupt by reading the `Px_DATA_REG` registers.

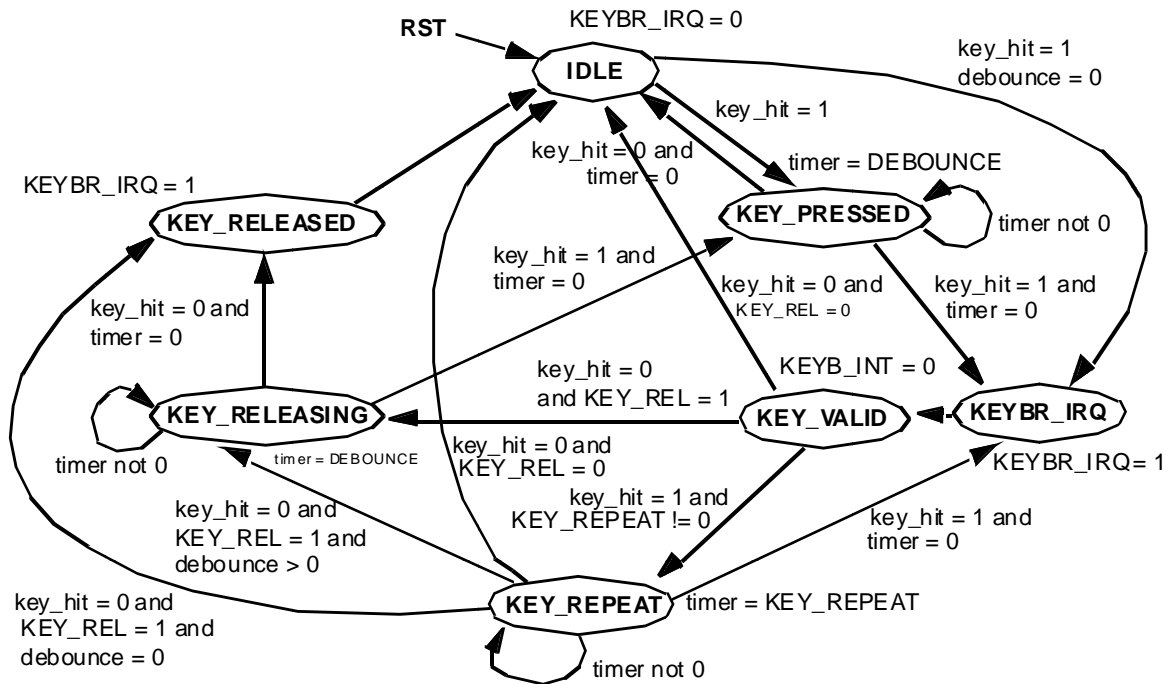

Figure 57: Keyboard Scanner State Machine

### 24.2.2 GPIO Interrupt Generator

Five identical GPIO interrupt generators support the generation of up to five interrupts (GPIO0\_IRQ to GPIO4\_IRQ). One of the GPIO inputs can be selected to generate an interrupt by programming the corresponding `GPIO_IRQx_IN_SEL_REG` register. The input level can be selected by `GPIO_INT_LEVEL_CTRL_REG[INPUT_LEVELx]`.

A LOW-to-HIGH level transition on one of the GPIO inputs sets the internal signal "key\_hit" to 1, while the bit `INPUT_LEVELx = 0`. This signal triggers the state machine of the GPIO Interrupt Generator shown in Figure 58. The debounce timer is loaded with the value of `GPIO_DEBOUNCE_REG[DEB_VALUE]`. The timer counts down every 1 ms. If the timer reaches 0 and the "key\_hit" signal is still 1, an interrupt will be generated. The debounce timer for each interrupt can be disabled with `GPIO_DEBOUNCE_REG[DEB_ENABLEx]`.

The interrupt flag will remain set until it is reset by writing to the corresponding bit in the `GPIO_RESET_IRQ_REG` register. If the GPIO interrupt is edge sensitive selected with bit `GPIO_INT_LEVEL_CTRL_REG[EDGE_LEVELNx]`, the state machine will progress to the state `WAIT_FOR_RELEASE` when the interrupt is reset. It will progress to the `IDLE` state only after the non-active edge is detected.

To detect both signal edges, the edge polarity `INPUT_LEVELx` must be inverted in the `WAIT_FOR_RELEASE` state. This will result in "key\_hit" = 0 and will advance the state machine to the `IDLE` state, allowing the next inverted edge to be detected.

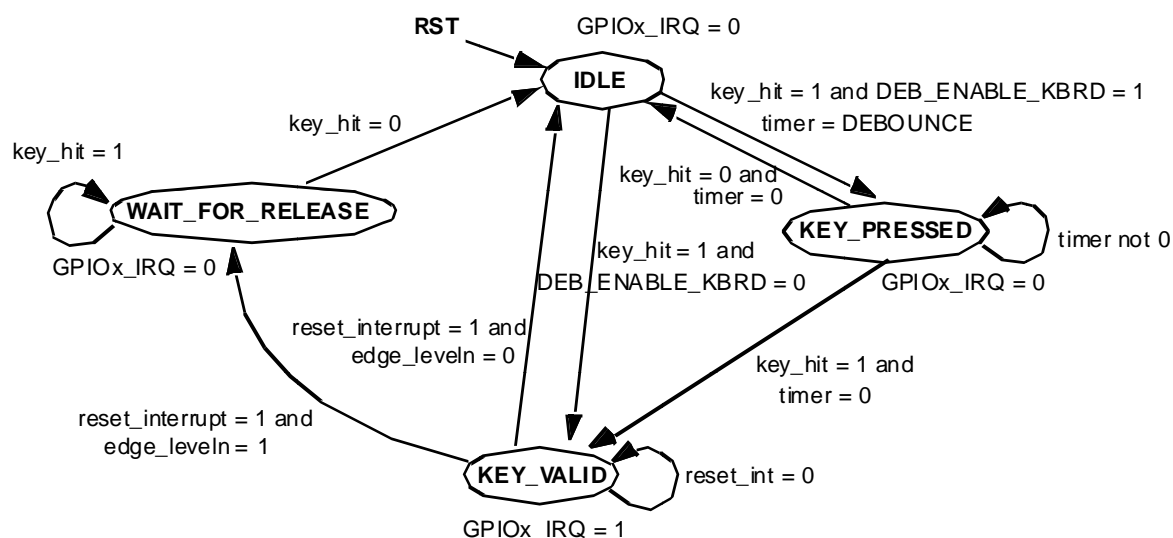

Figure 58: GPIO Interrupt Generator State Machine

## 24.3 Programming

To configure and use the Keyboard controller, follow the steps under each subsection.

### 24.3.1 Keyboard Scanner

1. Enable a keyboard interrupt for the P0\_x by setting the KBRD\_IRQ\_IN\_SEL0\_REG[KBRD\_Px\_EN] bit.
2. Select the logic level by which the interrupt is generated (KBRD\_CTRL\_REG[KBRD\_LEVEL]).
3. Select whether a key release also generates an interrupt (KBRD\_CTRL\_REG[KBRD\_REL]).
4. Select whether repeated interrupts will be generated when a key is held pressed (KBRD\_CTRL\_REG[KEY\_REPEAT]).
5. Set up the debounce time for each key stroke (GPIO\_DEBOUNCE\_REG[DEB\_VALUE]).
6. Enable the debounce timer (GPIO\_DEBOUNCE\_REG[DEB\_ENABLE\_KBRD]).

### 24.3.2 GPIO Interrupts

1. Enable a GPIO interrupt for the P0\_x by setting the GPIO\_IRQx\_IN\_SEL\_REG[KBRD\_IRQ0\_SEL] bit.
2. Select the logic level by which the interrupt is generated (GPIO\_INT\_LEVEL\_CTRL\_REG[INPUT\_LEVELx]).
3. Select whether a key release is needed for an interrupt to be generated after a generated IRQ is cleared (GPIO\_INT\_LEVEL\_CTRL\_REG[EDGE\_LEVELNx]).
4. Set up the debounce time for GPIO trigger (GPIO\_DEBOUNCE\_REG[DEB\_VALUE]).
5. Enable the debounce timer for the selected IRQ (GPIO\_DEBOUNCE\_REG[DEB\_ENABLEx]).

## 25 Input/Output Ports

### 25.1 Introduction

The DA14530 has an I/O pin assignment that can be configured by the SW and is organized into the Port 0. Pins from P0\_0 to P0\_5 are available for input/output on the WLCSP17 package, whereas the full Port 0 (P0\_0 to P0\_11) is available on the FCGQFN24 package. Figure 59 shows the block diagram of the IO and its programmability options.

#### Features

- Six GPIOs on WLCSP17 and 12 GPIOs on FCGQFN24 (including RST, SW\_CLK, SWDIO, XTAL32Km, and XTAL32Kp)
- Fully programmable pin assignment
- Selectable 25 kΩ pull-up and pull-down resistors per pin
- Programmable driving strength outputs
- Fixed assignment for analog pin ADC[3:0]
- Pins can retain their last state when system enters a Sleep mode

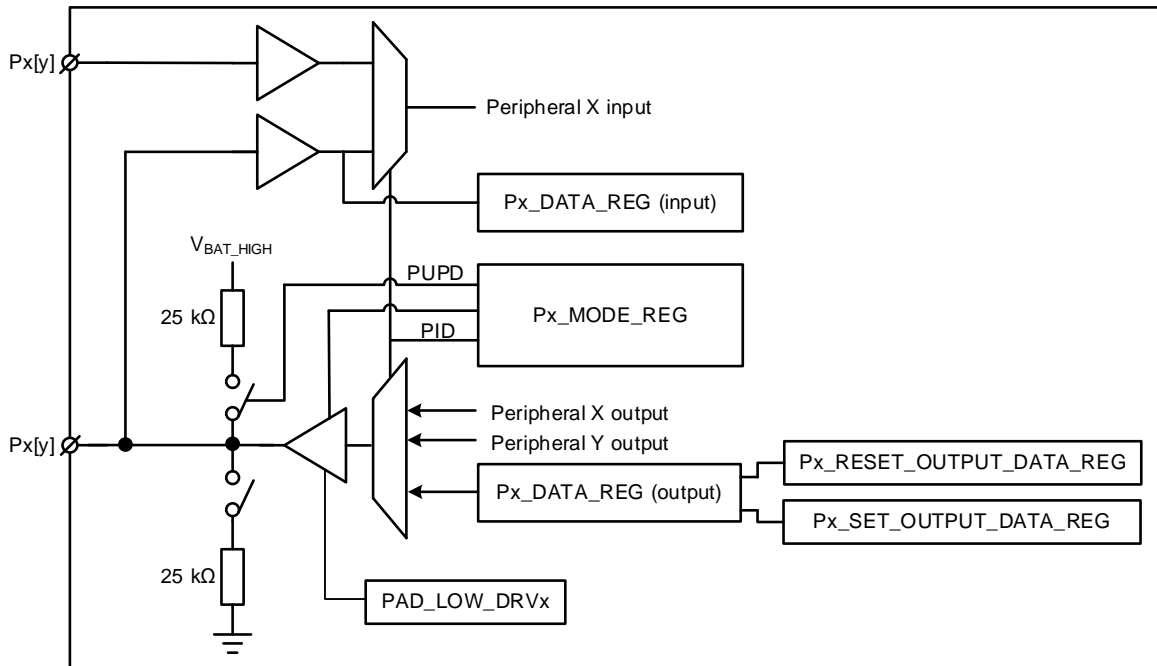

Figure 59: Port P0 with Programmable Pin Assignment and driving strength

### 25.2 Architecture

#### 25.2.1 Programmable Pin Assignment

The Programmable Pin Assignment (PPA) provides a multiplexing function to the I/O pins of on-chip peripherals. Any peripheral input or output signal can be freely mapped to any I/O port bit by setting Pxy\_MODE\_REG[4-0]:

0x00 to 0x1F: Peripheral IO ID (PID)

Refer to the registers of P<sub>x</sub>\_MODE\_REG (x = 00, 01, 02, to 11) for an overview of the available PIDs. The analog ADC has a fixed pin assignment so that the interference with the digital domain is limited. The SWD interface (JTAG) is mapped on P0\_5 (or P0\_1 or P0\_10, see chapter 2 Pinout) for the SWDIO and on P0\_2 for the SWCLK.

**25.2.1.1 Priority**

The firmware can assign the same peripheral output to more than one pin. It is the users' responsibility to make a unique assignment.

If more than one input signal is assigned to a peripheral input, the left most pin in the lowest port pin number has priority.

**25.2.1.2 Direction Control**

The port direction is controlled by setting Pxy\_MODE\_REG[9-8] to:

- 00 = Input, no resistors selected
- 01 = Input, pull-up resistors selected
- 10 = Input, pull-down resistors selected
- 11 = Output, no resistors selected

In output mode and analog mode, the pull-up/down resistors are automatically disabled.

**25.2.2 General Purpose Port Registers**

The general-purpose ports are selected with PID = 0. The port function is accessible through registers:

- Px\_DATA\_REG: Port data input/output register
- Px\_SET\_OUTPUT\_DATA\_REG: Port set output register
- Px\_RESET\_OUTPUT\_DATA\_REG: Port reset output register

**25.2.2.1 Port Data Register**

The registers input Px\_DATA\_REG and output Px\_DATA\_REG are mapped on the same address.

The data input register (Px\_DATA\_REG) is a read-only register that returns the current state on each port pin, even if the output direction is selected, regardless of the programmed PID, unless the analog function is selected (in this case it reads 0). The Cortex CPU can read this register at any time, even when the pin is configured as an output.

The data output register (Px\_DATA\_REG) holds the data to be driven on the output port pins. In this configuration, writing to this register changes the output value.

**25.2.2.2 Port Set Data Output Register**

Writing a 1 in the set data output register (Px\_SET\_DATA\_REG) sets the corresponding output pin. Writing a 0 is ignored.

**25.2.2.3 Port Reset Data Output Register**

Writing a 1 in the reset data output register (Px\_RESET\_DATA\_REG) resets the corresponding output pin. Writing a 0 is ignored.

**25.2.3 Fixed Assignment Functionality**

Certain signals have a fixed mapping on specific general purpose IOs. This assignment is illustrated in [Table 44](#).

**Table 44: Fixed Assignment of Specific Signals**

GPIO	Reset/SWD (Note 3)	QUADRATURE DECODER (Note 4)	ADC (Note 5)
P0_0	RST	CH6_A	
P0_1	SWDIO (alternative)	CH1_A	ADC_0

GPIO	Reset/SWD (Note 3)	QUADRATURE DECODER (Note 4)	ADC (Note 5)
P0_2	SWCLK	CH1_B	ADC_1
P0_3		CH2_A	
P0_4		CH2_B	
P0_5	SWDIO	CH3_A	
P0_6		CH3_B	ADC_2
P0_7		CH4_A	ADC_3
P0_8		CH6_B	
P0_9		CH5_A	
P0_10	SWDIO (alternative)	CH5_B	
P0_11		CH4_B	

**Note 3** The SWD signal mapping is defined by SYS\_CTRL\_REG[DEBUGGER\_ENABLE]. However, these signals are mapped on the ports by default. The alternative SWD mapping is selected by the SYS\_CTRL\_REG[DEBUGGER\_ENABLE] bit field. The RST default functionality can be disabled by the HWR\_CTRL\_REG[DISABLE\_HWR] bit.

**Note 4** The mapping of the quadrature decoder signals on the respective pins is overruled by the QDEC\_CTRL2\_REG[CHx\_PORT\_SEL] register.

**Note 5** The ADC function can be selected by the PID bit field on the respective Px port.

### 25.2.4 Types of GPIO Pads

There are two different types for the GPIO pads, namely, type A and type B. Their block diagrams are presented in Figure 60 and Figure 61.

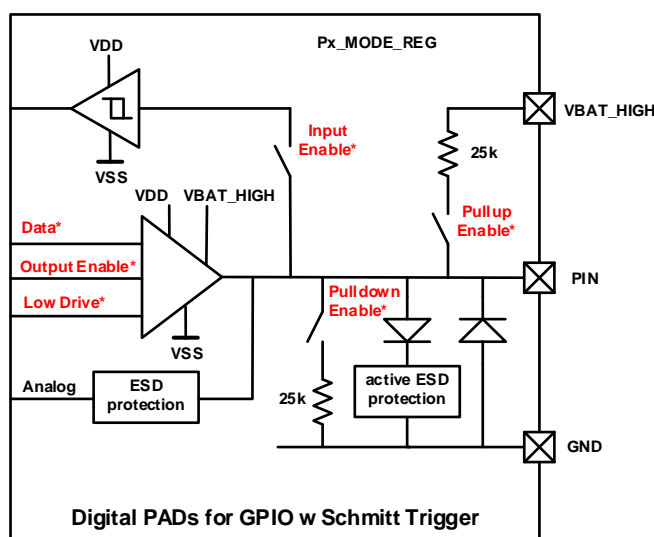

Figure 60: Type A GPIO Pad - GPIO with Schmitt Trigger on Input

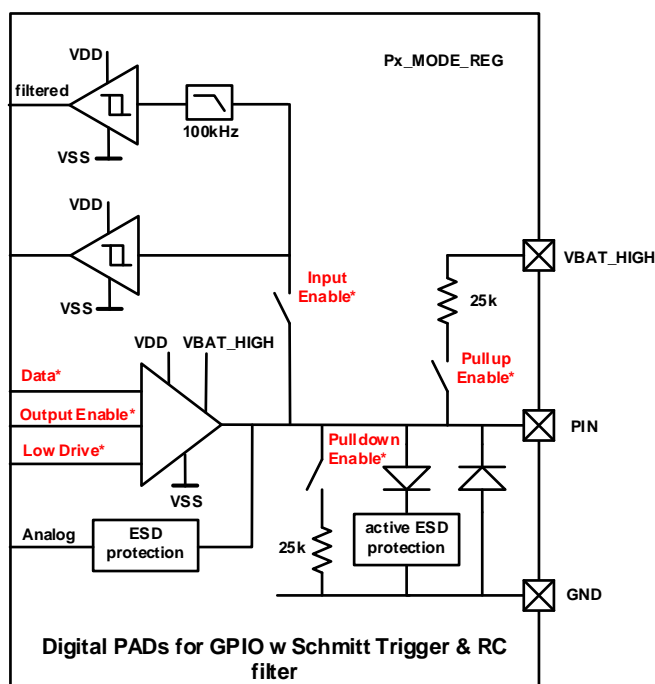

Figure 61: Type B GPIO Pad - GPIO with Schmitt Trigger and RC Filter on Input

Red signals are latched when the system enters a Sleep mode.

### 25.2.5 Driving Strength

Pads can be configured regarding their driving capability using PAD\_WEAK\_CTRL\_REG. There are only 2 levels available for the load that the pad can support, namely normal=3.5mA typical, and reduced=0.35mA typical.

## 26 General Purpose ADC

### 26.1 Introduction

The DA14530 is equipped with a high-speed ultra-low-power 10-bit general purpose Analog-to-Digital Converter (GPADC). It can operate in unipolar (single ended) mode as well as in bipolar (differential) mode. The ADC has its own voltage regulator (LDO) of 0.9 V, which represents the full-scale reference voltage. [Figure 62](#) shows the block diagram of the GPADC.

#### Features

- 10-bit dynamic ADC with 125 ns typical conversion time
- Maximum sampling rate 1 Msample/s
- 128x averaging; conversion time 1 ms, up to 11b ENOB
- Ultra-low power (20  $\mu$ A typical supply current at 100 ksample/s)
- Four single-ended or two differential external input channels (GPIOs)
- Battery and the internal  $V_{DD}$  monitoring channels
- Chopper function
- Offset adjust
- Common-mode input level adjust
- Configurable attenuator: 1x, 2x, 3x and 4x
- Input shifter

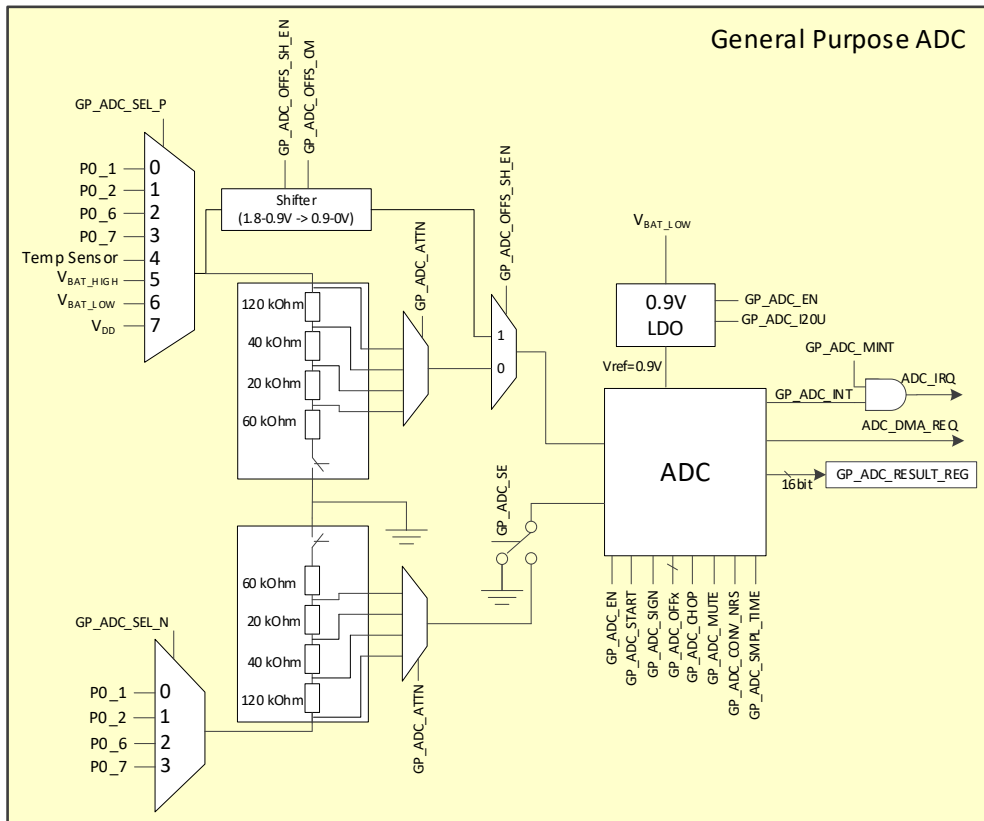

Figure 62: Block Diagram of GPADC

### 26.2 Architecture

The ADC architecture shown in [Figure 62](#) has the following sub-blocks:

- Analog to Digital converter (ADC)
  - ADC analog part internally clocked with 100 MHz
  - ADC logic part clocked with the ADC\_CLK which is the 16 MHz system clock (sys\_clk)
- 0.9 V LDO for the ADC supply with a high PSRR enabled with GP\_ADC\_CTRL\_REG[GP\_ADC\_EN]
- Configurable attenuator with 1x, 2x, 3x, and 4x attenuation controlled by GP\_ADC\_CTRL2\_REG[GP\_ADC\_ATTEN]
- Input shifter which shifts the battery voltage range from 0.85 V to 1.75 V (with a common mode adjustment) to the ADC input range from 0 V to 0.9 V controlled by GP\_ADC\_CTRL2\_REG[GP\_ADC\_OFFSET\_SH\_EN] and GP\_ADC\_CTRL2\_REG[GP\_ADC\_OFFSET\_CM]
- APB Bus interface clocked with the APB clock. Control and status registers are available through registers GP\_ADC\_\*
- Maskable Interrupt (ADC\_IRQ) and DMA request (ADC\_DMA\_REQ)
- ADC input channel selector. Up to four GPIO ports, the battery, the internal V<sub>DD</sub>, and the analog ground level (AVS) can be measured.

### 26.2.1 Input Channels

Table 45 summarizes the ADC input channels. The GPIO signals at the channels [3:0] can be monitored both single-ended and differentially. The signals at the 4-7 inputs can be monitored single-ended or differentially with respect to the GPIOs.

**Table 45: ADC Input Channels**

Channel	Signal	Description
3:0	GPIO [P0_1, P0_2, P0_6, P0_7]	General Purpose Inputs
4	Temperature Sensor	Temperature Sensor
5	V <sub>BAT_HIGH</sub> <sup>2</sup>	V <sub>BAT_HIGH</sub> rail
6	V <sub>BAT_LOW</sub>	V <sub>BAT_LOW</sub> rail
7	V <sub>DD</sub>	V <sub>DD</sub> rail for the digital power domain

Table 46 summarizes the voltage ranges which can be handled with the single-ended or differential operation for different attenuation values. The single-ended/differential mode is controlled by the bit GP\_ADC\_CTRL\_REG[GP\_ADC\_SE], and the attenuation is handled by the bit GP\_ADC\_CTRL2\_REG[GP\_ADC\_ATTEN].

**Table 46: GPADC External Input Channels and Voltage Range**

GP_ADC_ATTEN	GP_ADC_SE	Input Scale	Input Limits
0 (1 x)	0	-0.9 V to +0.9 V	-1 V to +1 V
	1	0 V to +0.9 V	-0.1 V to 1V
1 (2 x)	0	-1.8 V to +1.8 V	-1.9 V to +1.9 V
	1	0 V to +1.8 V	-0.1 V to 1.9 V
2 (3 x)	0	-2.7 V to +2.7 V	-2.8 V to +2.8 V
	1	0 V to +2.7 V	-0.1 V to 2.8 V
3 (4 x)	0	-3.6 V to +3.6 V	-3.45 V to +3.45 V
	1	0 V to +3.6 V	-0.1 V to 3.45 V

<sup>2</sup> V<sub>BAT\_HIGH</sub> and V<sub>BAT\_LOW</sub> are equal to V<sub>BAT</sub> (the battery voltage)



26.2.2 Operating Modes

The GPADC operation flow diagram is shown in Figure 63.

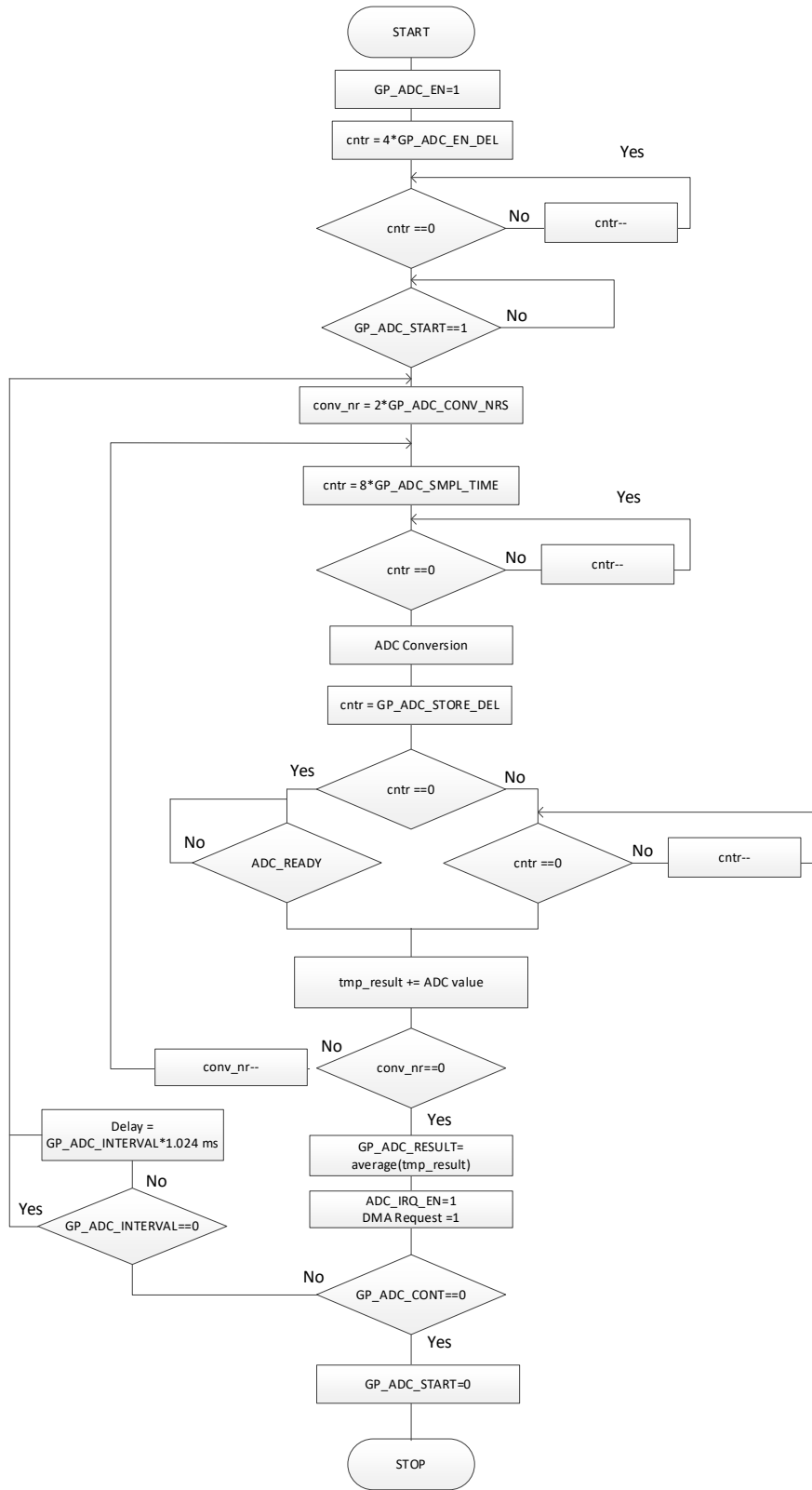

Figure 63: GPADC Operation Flow Diagram

**26.2.2.1 Enabling the ADC**

Enabling/disabling of the ADC is triggered by configuring bit GP\_ADC\_CTRL\_REG[GP\_ADC\_EN]. When the bit is set to 1, first the LDO is enabled. Then after the delay value set in GP\_ADC\_CTRL3\_REG[GP\_ADC\_EN\_DEL] (typically 16 μs to account for the LDO settling time), the ADC will be enabled, and an AD conversion can be started. See Table 47 for recommended values.

**Table 47: ADC\_LDO Start-Up Delay**

f <sub>ADC_CLK</sub>	GP_ADC_EN_DEL	T <sub>ADC_EN_DEL</sub>
16 MHz	0x40	16 μs

Formula:

$$GP\_ADC\_EN\_DEL = T_{ADC\_EN\_DEL} \times f_{ADC\_CLK} / 4$$

This value must be rounded up to the nearest integer.

The GPADC is a dynamic ADC and consumes no static power, except for the **ADC\_LDO** which consumes approximately 20 μA. Therefore, GP\_ADC\_EN must be set to 0 if the ADC is not used.

**26.2.2.2 Manual Mode**

An AD conversion can be started by setting GP\_ADC\_START to 1. While a conversion is active, GP\_ADC\_START remains 1. When a conversion is finished, the hardware sets GP\_ADC\_START to 0 and GP\_ADC\_INT to 1 (interrupt), and GP\_ADC\_RESULT\_REG contains the valid ADC value. While a conversion is active, writing 1 to GP\_ADC\_START will not start a new conversion. SW should always check that bit GP\_ADC\_START = 0 before starting a new conversion.

**26.2.2.3 Continuous Mode**

Setting GP\_ADC\_CTRL\_REG[GP\_ADC\_CONT] to 1 enables the continuous mode, which automatically starts a new AD conversion when the current conversion has been completed. The GP\_ADC\_START bit is only needed once to trigger the first conversion. As long as the continuous mode is active, GP\_ADC\_RESULT\_REG always contains the latest ADC value.

To correctly terminate the continuous mode, it is required to disable the GP\_ADC\_CONT bit first and then wait until the GP\_ADC\_START bit is cleared to 0, so the ADC is in a defined state.

<b>NOTE</b>
Before making any changes to the ADC settings, users must disable the continuous mode by setting bit GP_ADC_CONT to 0 and waiting until bit GP_ADC_START = 0.

At full speed the ADC consumes approximately 50 to 60 μA. If the data rate is less than 100 ksamples/s, the current consumption will be in the order of 25 μA.

The time interval between two successive AD conversions is programmable with GP\_ADC\_CTRL3\_REG[GP\_ADC\_INTERVAL] in steps of 1.024 ms. If GP\_ADC\_INTERVAL = 0, the conversion will restart immediately. If GP\_ADC\_INTERVAL is not zero, the ADC first synchronizes to the delay clock before starting the conversion. This can take up to 1 ms.

**26.2.3 Conversion Modes**
**26.2.3.1 AD Conversion**

Each AD conversion has three phases:

- Sampling
- Conversion
- Storage

The AD conversion starts with the sampling phase. This phase ends after the time set in GP\_ADC\_CTRL2\_REG[GP\_ADC\_SMPL\_TIME] and triggers the conversion phase. If GP\_ADC\_CTRL2\_REG[GP\_ADC\_STORE\_DEL] = 0, handshaking is used, that is, the ADC result is stored when a conversion is finished. Otherwise, a fixed (programmable) delay is used, and the result is stored regardless of whether the conversion is finished or not.

The total conversion time of an AD conversion depends on various settings. In short, it is as follows.

$$T_{ADC} = \frac{N_{CONV} \cdot (N_{CYCL\_SMPL} + N_{CYCL\_STORE})}{f_{ADC\_CLK}} \quad (5)$$

Where

- $N_{CONV}$  = the number of conversions. This is related to the value programmed in GP\_ADC\_CTRL2\_REG[GP\_ADC\_CONV\_NRS], following  $2^{GP\_ADC\_CONV\_NRS}$ . When GP\_ADC\_CTRL2\_REG[GP\_ADC\_CHOP] is set, the minimum value for  $N_{CONV}$  is always 2.
- $N_{CYCL\_SMPL}$  = the number of ADC\_CLK cycles used for sampling, which is  $8 \times GP\_ADC\_CTRL2\_REG[GP\_ADC\_SMPL\_TIME]$ .
- $N_{CYCL\_STORE}$  = the number of ADC\_CLK cycles until the result is stored. When GP\_ADC\_CTRL2\_REG[GP\_ADC\_STORE\_DEL] = 0, handshaking is used. With handshaking, the number of ADC\_CLK cycles is typically three. This value may spread from sample to sample and over temperature, otherwise the number of ADC\_CLK cycles is GP\_ADC\_CTRL2\_REG[GP\_ADC\_STORE\_DEL] + 1.

### Sampling Phase

The sampling time can be programmed via GP\_ADC\_CTRL2\_REG[GP\_ADC\_SMPL\_TIME] and depends on the sampling time constant in combination with the desired sampling accuracy. This sampling time constant,  $T_{ADC\_SMPL}$  (Table 48), then depends on the output impedance of the source, the internal resistive dividers, and the internal sampling capacitor. And the number of required time constants is given by the natural logarithm of the desired accuracy, that is,  $\ln(2^{N_{BIT}})$ . For  $N_{BIT} = 10$ -bit accuracy, 7 time constants are required.

**Table 48: ADC Sampling Time Constant ( $T_{ADC\_SMPL}$ )**

ADC Input	$T_{ADC\_SMPL}$
GPADC0, GPADC1 (GP_ADC_ATTEN = 0)	$R_{OUT} \times 0.5 \text{ pF}$ (Differential Input) $R_{OUT} \times 1 \text{ pF}$ (Single-Ended Input)
GPADC0, GPADC1 (GP_ADC_ATTEN = 1)	$(R_{OUT} + 120 \text{ k}\Omega) \times 0.5 \text{ pF}$ (Differential Input) $(R_{OUT} + 120 \text{ k}\Omega) \times 1 \text{ pF}$ (Single-Ended Input)

Formula:

$$GP\_ADC\_SMPL\_TIME = \ln(2^{N_{BIT}}) \times T_{ADC\_SMPL} \times f_{ADC\_CLK} / 8$$

This value must be rounded up to the nearest integer.

### Conversion and Storage Phase

**One AD conversion typically takes around 125 ns with a 100 MHz clock.** The result can be stored either by handshaking or after a fixed number of cycles (programmable).

- Handshake mode (GP\_ADC\_STORE\_DEL = 0):

In handshake mode the conversion result is available in GP\_ADC\_RESULT\_REG after two sampling ADC\_CLK cycles plus two conversion ADC\_CLK cycles plus two ADC\_CLK cycles for synchronization.

- Fixed delay mode (GP\_ADC\_STORE\_DEL > 0):

In fixed delay mode the conversion result is available in GP\_ADC\_RESULT\_REG after the programmed storage delay, regardless of whether the conversion is ready or not. Note that when the

delay is too short (that is, the conversion is not finished in the allocated time), the old (previous) ADC result is stored.

### 26.2.3.2 Averaging

In order to reduce noise and improve performance, multiple samples can be averaged out (assuming the time average of noise equals zero). This is handled by HW and can be controlled by setting GP\_ADC\_CTRL2\_REG[GP\_ADC\_CONV\_NRS] to a non-zero value. The actual number of the consecutive samples taken is by  $2^{GP\_ADC\_CONV\_NRS}$ .

Because the internal noise also acts as a form of dither, the actual accuracy can be improved. Therefore, the ADC result is not truncated to 10-bit but stored as 16-bit left aligned, and truncation is left for the user. The expected Effective Number of Bits (ENOB) is shown in [Table 49](#).

**Table 49: ENOB in Oversampling Mode**

GP_ADC_CONV_NRS	ENOB (Left Aligned) in GP_ADC_RESULT_REG
0	> 9
1	> 9
2	> 9
3	> 10
4	> 10
5	> 10
6	> 11
7	> 11

### 26.2.3.3 Chopper Mode

Inherently, the ADC has a DC offset ( $E_{OFS}$ ). When GP\_ADC\_CTRL\_REG[GP\_ADC\_CHOP] is set to 1, the hardware triggers two consecutive AD conversions and flips the sign of the offset in-between. Summing the two samples effectively cancels out the inherent ADC offset. This method also smooths other non-ideal effects and is recommended for DC and the slowly changing signals.

When combined with averaging, every other AD conversion is taken with opposite sign. Without averaging two AD conversions are always triggered.

Note that a DC offset causes saturation effects at zero scale or full scale. When chopping is used without offset calibration, non-linear behavior is introduced towards zero scale and full scale.

### 26.2.4 Additional Settings

The hardware also supports pre-ADC attenuation via GP\_ADC\_CTRL2\_REG[GP\_ADC\_ATTN]:

- Setting 0 disables the attenuator
- Setting 1 scales the input range by a factor of two
- Setting 2 scales the input range by a factor of three
- Setting 3 scales the input range by a factor of four

With bit GP\_ADC\_CTRL\_REG[GP\_ADC\_MUTE] = 1, the input is connected to  $0.5 \times$  ADC reference. So, the ideal ADC result should be 511.5. Any deviation from this is the ADC offset.

With bit GP\_ADC\_CTRL\_REG[GP\_ADC\_SIGN] = 1, the sign of the offset is inverted. When chopper is used, the hardware alternates GP\_ADC\_SIGN = 0 and 1. This bit is typically only used for the offset calibration routine described in section [26.2.6](#) and has no specific use to the end user.

### 26.2.5 Non-Ideal Effects

Besides Differential Non-Linearity (DNL) and Integral Non-Linearity (INL), each ADC has a gain error (linear) and an offset error (linear). The gain error ( $E_G$ ) of the GPADC affects the effective input range. The offset error ( $E_{OFS}$ ) causes the effective input scale to become non-centered. The offset error can be reduced by chopping and/or by offset calibration.

The ADC result will also include some noise. If the input signal itself is noise free (inductive effects included), the average noise level will be  $\pm 1$  LSB. Reducing noise effects can be done by taking more samples and calculating the average value. This can be done by programming `GP_ADC_CTRL2_REG[GP_ADC_CONV_NRS]` to a non-zero value.

With a “perfect” input signal (for example, if a filter capacitor is placed close to the input pin), most of the noise comes from the low-power voltage regulator (LDO) of the ADC. Since the DA14530 is targeted for ultra-compact applications, there is no pin available to add a capacitor at this voltage regulator output.

The dynamic current of the ADC causes extra noise at the regulator output. This noise can be reduced by setting bits `GP_ADC_CTRL2_REG[GP_ADC_I20U]`. Bit `GP_ADC_I20U` enables a constant 20  $\mu$ A load current at the regulator output so that the current will not drop to zero. This, obviously, increases power consumption by 20  $\mu$ A.

### 26.2.6 Offset Calibration

A relative high offset error ( $E_{OFS}$ , up to 30 mV, so approximately 30 LSB) is caused by a very small dynamic comparator. This offset error can be cancelled with the chopping function, but it still causes unwanted saturation effects at zero scale or full scale. With `GP_ADC_OFFP_REG` and `GP_ADC_OFFN_REG`, the offset error can be compensated in the ADC network itself. To calibrate the ADC, follow the steps in [Table 50](#). In this routine, 0x200 is the target mid-scale of the ADC.

**Table 50: GPADC Calibration Procedure for Single-Ended and Differential Modes**

Step	Single-Ended Mode ( <code>GP_ADC_SE = 1</code> )	Differential Mode ( <code>GP_ADC_SE = 0</code> )
1	Set <code>GP_ADC_OFFP = GP_ADC_OFFN = 0x200</code> ; <code>GP_ADC_MUTE = 0x1</code> ; <code>GP_ADC_SIGN = 0x0</code> .	Set <code>GP_ADC_OFFP = GP_ADC_OFFN = 0x200</code> ; <code>GP_ADC_MUTE = 0x1</code> ; <code>GP_ADC_SIGN = 0x0</code> .
2	Start conversion.	Start conversion.
3	<code>adc_off_p = GP_ADC_RESULT - 0x200</code>	<code>adc_off_p = GP_ADC_RESULT - 0x200</code>
4	Set <code>GP_ADC_SIGN = 0x1</code> .	Set <code>GP_ADC_SIGN = 0x1</code> .
5	Start conversion.	Start conversion.
6	<code>adc_off_n = GP_ADC_RESULT - 0x200</code>	<code>adc_off_n = GP_ADC_RESULT - 0x200</code>
7	<code>GP_ADC_OFFP = 0x200 - 2 x adc_off_p</code> <code>GP_ADC_OFFN = 0x200 - 2 x adc_off_n</code>	<code>GP_ADC_OFFP = 0x200 - adc_off_p</code> <code>GP_ADC_OFFN = 0x200 - adc_off_n</code>

In order to increase the accuracy, it is recommended to set the `GP_ADC_CTRL2_REG[GP_ADC_SMPL_TIME] = 2` or `3` and `GP_ADC_CTRL2_REG[GP_ADC_CONV_NRS] = 3` or `4` prior to this routine.

It is recommended to implement the above calibration routine during the initialization phase of DA14530. To verify the calibration results, check whether the `GP_ADC_RESULT` value is close to 0x200 while bit `GP_ADC_CTRL_REG[GP_ADC_MUTE] = 1`.

### 26.2.7 Zero-Scale Adjustment

The `GP_ADC_OFFP` and `GP_ADC_OFFN` registers can also be used to set the zero-scale or full-scale input level at a certain target value. For instance, they can be used to calibrate `GP_ADC_RESULT` to 0x000 at an input voltage of exactly 0.0 V, or to calibrate the zero scale of a sensor.

### 26.2.8 Common Mode Adjustment

The common mode level of the differential signal must be  $0.45\text{ V} = \text{Full Scale}/2$  (or  $1.35\text{ V}$  with  $\text{GP\_ADC\_ATTN} = 2$ , that is,  $3\times$  attenuation). If the common mode input level of  $0.45\text{ V}$  cannot be achieved, the common mode level of the GPADC can be adjusted via  $\text{GP\_ADC\_OFFP\_REG}$  and  $\text{GP\_ADC\_OFFN\_REG}$  according to [Table 51](#). The GPADC can tolerate a common mode margin of up to  $50\text{ mV}$ .

**Table 51: Common Mode Adjustment**

CM Voltage ( $V_{\text{ccm}}$ )	GP_ADC_OFFP = GP_ADC_OFFN
0.225 V	0x300
0.450 V	0x200
0.675 V	0x100

Any other common mode levels between  $0.0\text{ V}$  and  $0.9\text{ V}$  can be calculated from [Table 51](#). Offset calibration can be combined with common mode adjustment by replacing the  $0x200$  value in the offset calibration routine with the value required to get the appropriate common mode level.

### 26.2.9 Input Impedance, Inductance, and Input Settling

The GPADC has no input buffer stage. During the sampling phase, a capacitor of  $0.5\text{ pF}$  in differential mode or  $1\text{ pF}$  in single-ended mode is switched to the input line(s). The pre-charge of this capacitor is at midscale level, so the input impedance is infinite.

During the sampling phase, a certain settling time is required. A 10-bit accuracy requires at least seven time constants  $T_{\text{ADC\_SMPL}}$ , determined by the output impedance of the input signal source, the internal resistive dividers, and the  $0.5\text{ pF}$  or  $1\text{ pF}$  sampling capacitor. See [Table 48](#).

The inductance from the signal source to the ADC input pin must be very small. Otherwise filter capacitors are required from the input pins to ground (single-ended mode) or from pin to pin (differential mode).

## 26.3 Programming

To program and use the GPADC, follow the simple sequence of steps below:

1. Enable the GPADC by setting the  $\text{GP\_ADC\_CTRL\_REG}[\text{GP\_ADC\_EN}]$  bit.
2. Set up the GPIO input ( $\text{P0\_x\_MODE\_REG}[\text{PID}] = 15$ ).
3. Select the input channel ( $\text{GP\_ADC\_SEL\_REG}$ ).
4. Select the sampling mode (differential or single ended) by writing the  $\text{GP\_ADC\_CTRL\_REG}[\text{GP\_ADC\_SE}]$  bit.
5. Select between the manual mode and the continuous mode of sampling ( $\text{GP\_ADC\_CTRL\_REG}[\text{GP\_ADC\_CONT}]$ ).
6. Set up extra options (see  $\text{GP\_ADC\_CTRLx\_REG}$  description)
7. Start the conversion by setting  $\text{GP\_ADC\_CTRL\_REG}[\text{GP\_ADC\_START}]$  bit.
8. Wait for  $\text{GP\_ADC\_CTRL\_REG}[\text{GP\_ADC\_START}]$  to become 0 or interrupt being triggered (when used).
9. Clear the ADC interrupt by writing any value to  $\text{GP\_ADC\_CLEAR\_INT\_REG}$ .
10. Get the ADC result from the  $\text{GP\_ADC\_RESULT\_REG}$ .

## 27 Real Time Clock (RTC)

### 27.1 Introduction

The DA14530 is equipped with a Real Time Clock (RTC) which provides the complete clock and calendar information with automatic time units adjustment and easy configuration.

#### Features

- Complete time of day clock: 12/24 hour, hours, minutes, seconds, and hundredths of a second
- Calendar function: day of week, date of month, month, year, century, leap year compensation, and year 2000 compliant
- Alarm function: month, date, hour, minute, second, and hundredths of a second
- Event interrupt on any calendar or time unit
- Available during sleep if the power domain PD\_TIM is kept alive
- Granularity of 10 ms (RTC\_CLK)
- Provides 22 LSB to Timer 1 upon a capture trigger

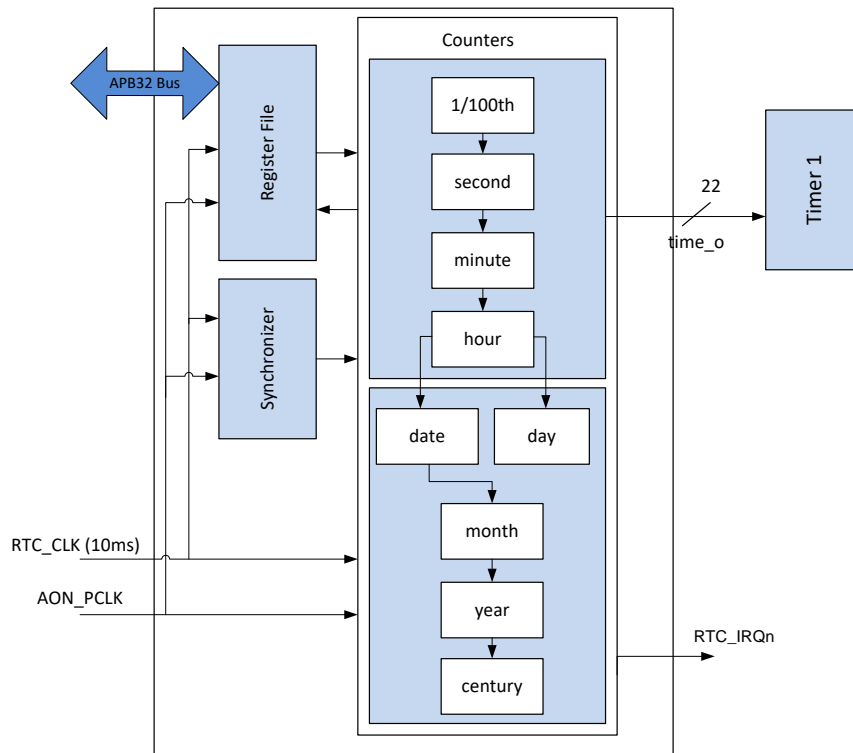

Figure 64: Real Time Clock Block Diagram

### 27.2 Architecture

The architecture of the RTC is depicted in Figure 64.

The RTC supports a year range from 1900 to 2999 as well as full month, date, minute, second, and hundredth of second ranges. It also supports hour ranges of 0 to 23 (24-hour format) or 1 to 12 with a.m./p.m. flag (12-hour format).

Alarms can be generated in two ways, as a one-time alarm or as a recurring alarm. In addition to alarms, the RTC can detect when a particular event occurs. Each field of the calendar and time counter can generate an event when it rolls over. For example, an event can be generated every new month, new week, new day, new half day (12-hour mode), new minute, or new second. Both alarms



and events can generate an interrupt. All the interrupts can be set, enabled, disabled, or masked at any time.

The LSB (22) of the port showing a full of 32-bit information on the current time is latched by Timer 1 (TIMER1\_CAPCNT1/2\_VALUE\_REG) if instructed by Timer 1 configuration. This allows for storing an RTC based snapshot upon an event on a GPIO.

### 27.3 Programming

To configure the RTC, follow the simple sequence of steps below:

1. Configure the 100 Hz RTC granularity if needed:
  - a. Based on the selected LP clock (for example, 32768 kHz), set the CLK\_RTCDIV\_REG[RTC\_DIV\_INT] = 327 (= 0x147).  
This values should be equal to the integer divisor part of the formula  $F_{LP\_CLK}/100 = 327.680$ .
  - b. Based on the selected LP clock (for example, 32768 kHz), set the CLK\_RTCDIV\_REG[RTC\_DIV\_FRAC] = 680 (= 0x2A8).  
This values should be equal to the fractional divisor part of the formula  $F_{LP\_CLK}/100 = 327.680$ .
  - c. To achieve a better accuracy of the divisor, configure the denominator for the fractional division accordingly (CLK\_RTCDIV\_REG[RTC\_DIV\_DENOM]).
  - d. Enable the 100 Hz RTC granularity by setting the CLK\_RTCDIV\_REG [RTC\_DIV\_ENABLE] bit.
2. Enable the time functionality by clearing the RTC\_CONTROL\_REG[RTC\_TIME\_DISABLE].
3. Enable the calendar functionality by clearing the RTC\_CONTROL\_REG[RTC\_CAL\_DISABLE].
4. Choose between 12-hour or 24-hour mode (RTC\_HOUR\_MODE\_REG[RTC\_HMS]).
5. Configure the time (RTC\_TIME\_REG).
6. Configure the date (RTC\_CALENDAR\_REG).
7. Set up a time alarm if needed (RTC\_ALARM\_ENABLE\_REG).
8. Set up a calendar alarm if needed (RTC\_CALENDAR\_ALARM\_REG).
9. Enable the configured alarms (RTC\_ALARM\_ENABLE\_REG[RTC\_ALARM\_xxxx\_EN]).
10. Configure the interrupt generation when an alarm happens (RTC\_INTERRUPT\_ENABLE\_REG).  
Disable the interrupt generation with RTC\_INTERRUPT\_DISABLE\_REG.
11. Configure the event flag generation when an alarm happens (RTC\_EVENT\_FLAGS\_REG).
12. Define whether a SW reset resets the RTC (RTC\_KEEP\_RTC\_REG[RTC\_KEEP]).



## 28 Power

As discussed in [section 4.2](#), the integrated power management unit (PMU) comprises various LDOs, the  $V_{DD}$  Clamp, and the POR circuitry. The details of these blocks are discussed in the following sections.

### 28.1 LDOs

Several LDOs are used in the DA14530 to provide a stable power supply to the rails and the building blocks.

- $V_{DD\_Clamp}$  generates a trimmable  $\sim 0.75$  V  $V_{DD}$  supply voltage for the AON (always on) DCORE power domain from  $V_{BAT\_HIGH}$  or  $V_{BAT\_LOW}$  when the system is in the hibernation mode
- LDO\_CORE supplies the internal  $V_{DD}$  from  $V_{BAT\_LOW}$ . In the active mode it generates 0.9 V and in the sleep mode 0.75 V
- LDOs for the RF and the analog building blocks generate 0.9 V when the particular blocks are active. When the blocks are switched off, the LDOs are disabled.

### 28.2 POR Circuit

The POR\_LOW circuit issues a POR when the  $V_{BAT\_LOW}$  voltage is below the threshold voltage  $V_{IL}$  for more than 50  $\mu$ s. The POR is cleared when the battery voltage is above  $V_{IH}$  for at least 25  $\mu$ s. The threshold levels of the POR circuit are summarized in [section 3.12](#).

The POR\_HIGH circuit issues a POR when the  $V_{BAT\_HIGH}$  voltage is below the  $V_{IL}$  for more than 50  $\mu$ s. The POR is cleared when the battery voltage is above  $V_{IH}$  for at least 25  $\mu$ s. The threshold levels of the POR circuit are summarized in [section 3.12](#).

## 29 BLE Core

The Bluetooth Low Energy (BLE) core used in the DA14531 is a qualified Bluetooth 5.1 baseband controller compatible with the BLE specification and it is in charge of packet encoding/decoding and frame scheduling.

The block diagram of BLE core is presented in [Figure 65](#).

### Features

- Compliant with Bluetooth Core Specification, v5.1, Bluetooth SIG
  - Dual topology
  - Low duty cycle advertising
  - L2CAP connection-oriented channels
- All device classes support (Broadcaster, Central, Observer, and Peripheral)
- All packet types (Advertising, Data, and Control)
- Dedicated Encryption (AES/CCM)
- Bit stream processing (CRC and Whitening)
- FDMA/TDMA/events formatting and synchronization
- Frequency hopping calculation
- Operating clock 16 MHz or 8 MHz
- Low power modes supporting 32.0 kHz, 32.768 kHz, or 15 kHz
- Supports powerdown of the baseband during the protocol's idle periods

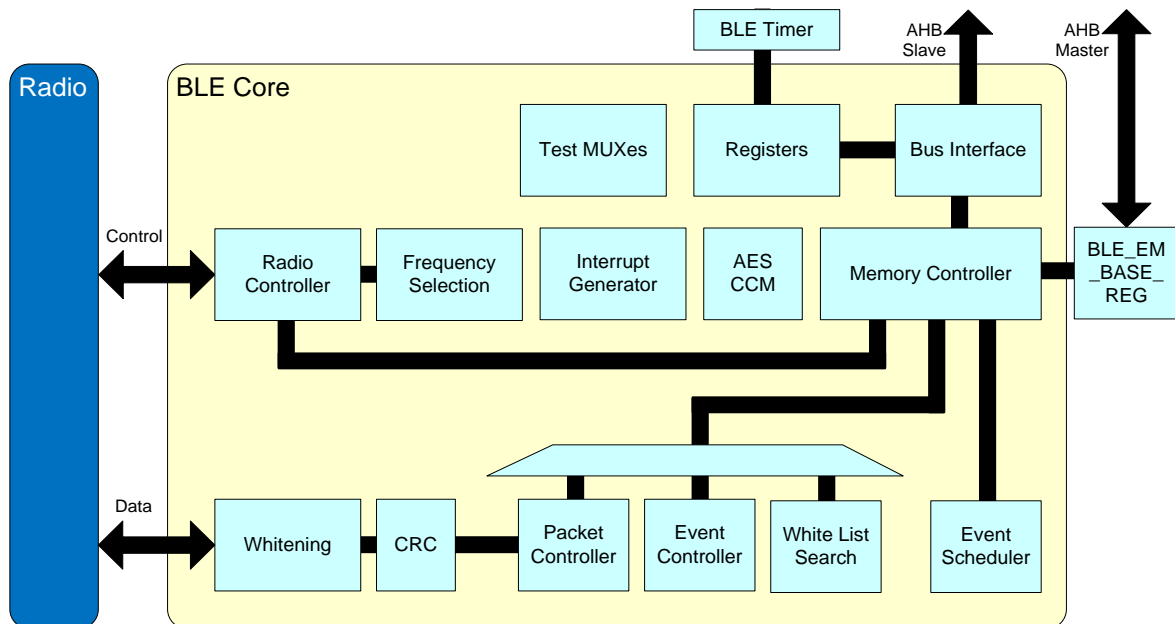

Figure 65: BLE Core Block Diagram

### 29.1 Architecture

#### 29.1.1 Exchange Memory

The BLE Core requires access to a memory space named "Exchange Memory" to store control structures and frame buffers. The access to Exchange Memory is performed via the AHB Master interface. The base address of the Exchange Memory is programmable by means of the BLE\_EM\_BASE register.

## 29.2 Programming

### 29.2.1 Wake-Up IRQ

Once the BLE core switches to "BLE Deep Sleep mode", the only way to correctly exit from this state is by generating initially the BLE\_WAKEUP\_LP\_IRQ and consecutively the BLE\_SLP\_IRQ. This sequence must be followed regardless of the cause of the termination of the "BLE Deep Sleep mode", that is, regardless of whether the BLE Timer has expired or BLE Timer has been stopped due to the assertion of BLE\_WAKEUP\_REQ.

The assertion and de-assertion of BLE\_WAKEUP\_LP\_IRQ is fully controlled via the BLE\_ENBPRESET\_REG bit fields. A detailed description is as follows:

- **TWIRQ\_SET:** it defines the number of "ble\_lp\_clk" cycles before the expiration of the BLE Timer when the BLE\_WAKEUP\_LP\_IRQ must be asserted. It is recommended to select a TWIRQ\_SET value larger than the amount of time that is required to finish trimming the XTAL 32 MHz (refer to XTAL32M\_TRIM\_READY) plus the execution time of the IRQ Handler. If the programmed value of TWIRQ\_SET is less than the minimum recommended value, the system will wake up but the actual BLE sleep duration (refer to BLE\_DEEPSLSTAT\_REG) will be larger than the programmed sleep duration (refer to BLE\_DEEPSLWKUP\_REG)
- **TWIRQ\_RESET:** it defines the number of "ble\_lp\_clk" cycles before the expiration of the sleep period when the BLE\_WAKEUP\_LP\_IRQ will be de-asserted. It is recommended to always set its value to "1"
- **TWEXT:** it determines the high period of BLE\_WAKEUP\_LP\_IRQ, if an external wake-up event (refer to GP\_CONTROL\_REG[BLE\_WAKEUP\_REQ]) occurs. Its minimum value is "TWIRQ\_RESET + X", where X is the number of "ble\_lp\_clk" clock cycles that BLE\_WAKEUP\_LP\_IRQ will be held high. The recommended value is "TWIRQ\_RESET + 1". Note that as soon as GP\_CONTROL\_REG[BLE\_WAKEUP\_REQ] is set to "1", the BLE\_WAKEUP\_LP\_IRQ will be asserted
- **Minimum BLE Sleep Duration:** The minimum value of BLE\_DEEPSLWKUP\_REG[DEEPSLTIME] bit, measured in "ble\_lp\_clk" cycles, is the higher value between (a) "TWIRQ\_SET + 1" and (b) the SW execution time from setting BLE\_DEEPSLCTRL\_REG[DEEP\_SLEEP\_ON] up to preparing CPU to accept the BLE\_WAKEUP\_LP\_IRQ (for example, to call the Cortex instruction WFI). If the programmed DEEPSLTIME is less than the minimum value of BLE\_DEEPSLWKUP\_REG[DEEPSLTIME], the BLE\_WAKEUP\_LP\_IRQ Handler may execute sooner than the call of the Cortex WFI instruction in the example and cause SW instability

### 29.2.2 Switch from BLE Active Mode to BLE Deep Sleep Mode

Software can set the BLE core into the "BLE Deep Sleep mode" by first programming the timing of BLE\_WAKEUP\_LP\_IRQ generation, then programming the desired sleep duration at BLE\_DEEPSLWKUP\_REG, and finally set the register bit BLE\_DEEPSLCTRL\_REG[DEEP\_SLEEP\_ON].

During the "BLE Deep Sleep mode", the BLE Core will switch to the "ble\_lp\_clk" (15kHz, 32.0 kHz, or 32.768 kHz) in order to maintain its internal 625  $\mu$ s timing reference. SW must poll the state of BLE\_CNTL2\_REG[RADIO\_PWRDN\_ALLOW] to detect the completion of this mode transition. Once the "ble\_lp\_clk" is used for base time reference, SW must disable the BLE clocks ("ble\_master1\_clk", "ble\_master2\_clk", and "ble\_crypt\_clk") by setting the CLK\_RADIO\_REG[BLE\_ENABLE] register bit to "0".

Finally, SW can optionally power down the Radio Subsystem by using the PMU\_CTRL\_REG[RADIO\_SLEEP] and the Peripheral and System power domains as well.

Figure 66 presents the waveforms when the BLE Deep Sleep mode is entered. In this case, as soon as the SW detects that RADIO\_PWRDOWN\_ALLOW is "1", it sets the PMU\_CTRL\_REG[RADIO\_SLEEP] to power down the Radio Subsystem. In Figure 66, Figure 67, Figure 68, Figure 69, and Figure 70, the corresponding BLE Core signals are marked with red while

Radio Subsystem is in power-down state and they remain red-marked during the period when RADIO\_SLEEP is set.

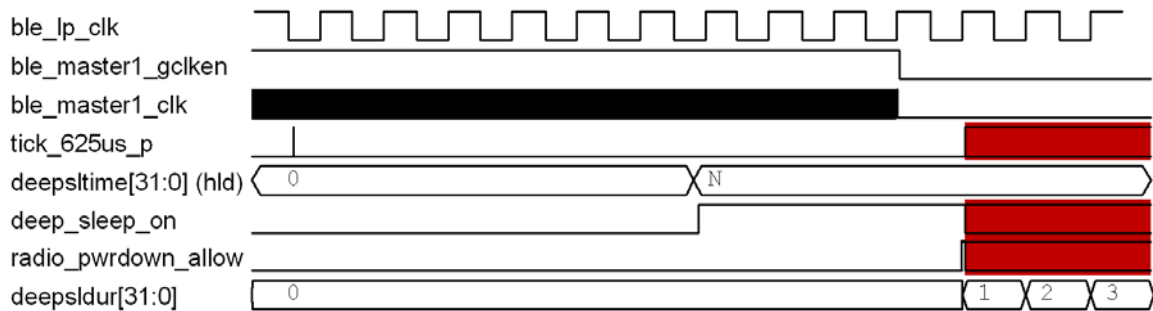

**Figure 66: Entering BLE Deep Sleep mode**

### 29.2.3 Switch from BLE Deep Sleep Mode to BLE Active Mode

There are two possibilities for the BLE Core to terminate the BLE Deep Sleep mode:

- Termination at the end of a predetermined time
- Termination on SW wake-up request due to an external event

#### 29.2.3.1 Switching at an Anchor Point

Figure 69 shows a typical BLE deep sleep phase that is terminated at a predetermined time. After a configurable time before the scheduled wake-up time (configured via BLE\_ENBPRESET\_REG register bit fields), the BLE Timer asserts the BLE\_WAKEUP\_LP\_IRQ in order to wake up the CPU (powering up the System Power Domain). The BLE\_WAKEUP\_LP\_IRQ Interrupt Handler will prepare the code environment and the XTAL32M oscillator stabilization (refer to SYS\_STAT\_REG[XTAL32\_SETTLED]) and will decide when the BLE Core is ready to exit the BLE Deep Sleep mode.

Once the SW decides that the BLE Core can wake up, it must enable the BLE clocks (via CLK\_RADIO\_REG[BLE\_ENABLE]) and power up the Radio Power Domain (refer to PMU\_CTRL\_REG[RADIO\_SLEEP] and SYS\_STAT\_REG[RAD\_IS\_UP]).

After the sleep period is expired (as specified in BLE\_DEEPSLWKUP\_REG[DEEPSLTIME]), the BLE Timer will not exit the BLE Deep Sleep mode until it detects that the BLE Core is powered up. That means, if the SW requires more time to power up the BLE Core, the final sleep duration (provided by BLE\_DEEPSLSTAT\_REG) will be longer than the preprogrammed value.

When the BLE Timer is expired, BLE clocks are enabled, and the BLE Core (Radio Subsystem) is powered up, the BLE Core exits the "BLE Core Deep Sleep mode" and asserts the BLE\_SLP\_IRQ.

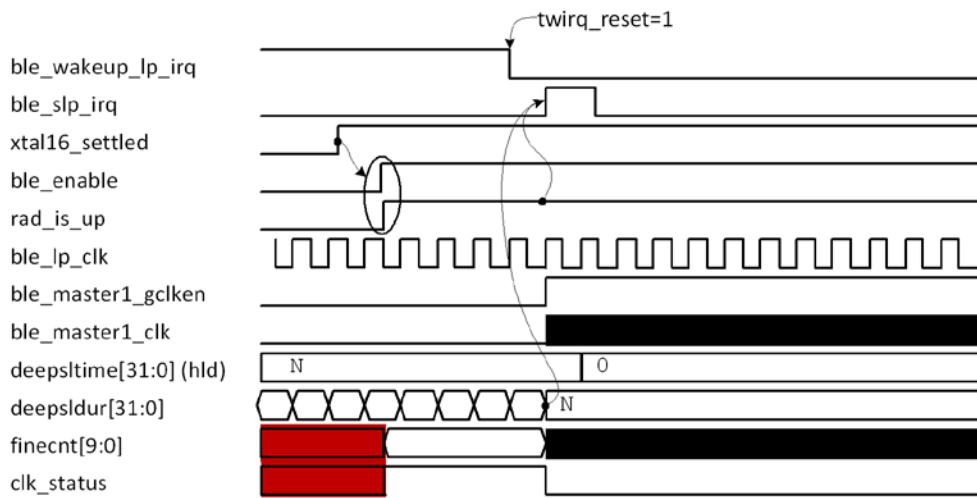

Figure 67: Exit BLE Deep Sleep Mode at Predetermined Time (Zoom In)

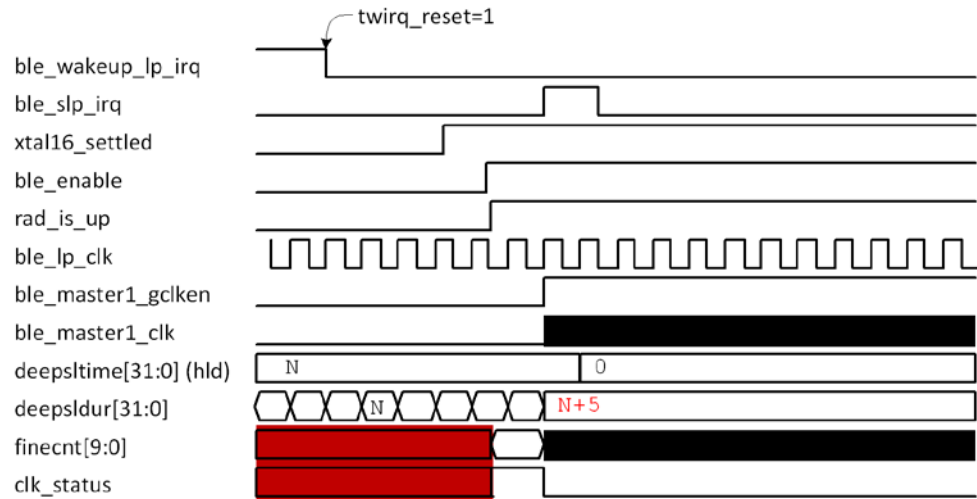

Figure 68: Exit BLE Deep Sleep Mode after Predetermined Time (Zoom In)

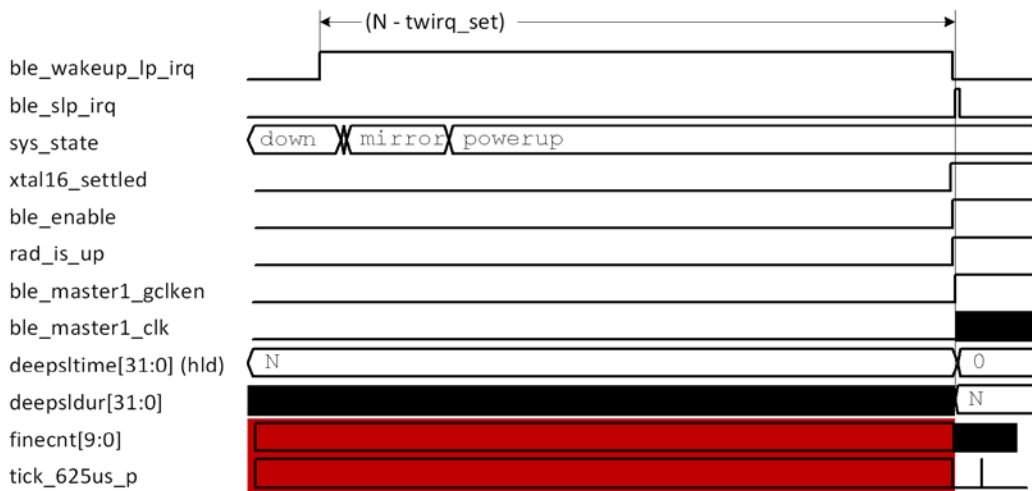

Figure 69: Exit BLE Deep Sleep Mode at Predetermined Time (Zoom Out)

#### 29.2.3.2 Switching Due to an External Event

Figure 70 shows a wakeup from a BLE deep sleep period forced by the assertion of register bit GP\_CONTROL\_REG[BLE\_WAKEUP\_REQ].

Assume that the system is in Extended Sleep state with all power domains switched off and both the wake-up timer and wake-up controller programmed appropriately. Then assume that an event is detected at one of the GPIOs, causing the System Power Domain to wake up due to WKUP\_QUADDEC\_IRQ. In that case, the SW will decide to wake up the BLE core, then it sets the GP\_CONTROL\_REG[BLE\_WAKEUP\_REQ] to 1 in order to force the wake-up sequence.

In Figure 70 the BLE\_WAKEUP\_REQ is raised by the SW as soon as possible, causing BLE\_WAKEUP\_LP\_IRQ Handler to be executed as soon as possible. It is also possible to raise BLE\_WAKEUP\_REQ after the detection of XTAL32\_TRIM\_READY, causing both BLE\_WAKEUP\_LP\_IRQ and BLE\_SLP\_IRQ Handlers to be executed sequentially. The decision depends on the SW structure and the application.

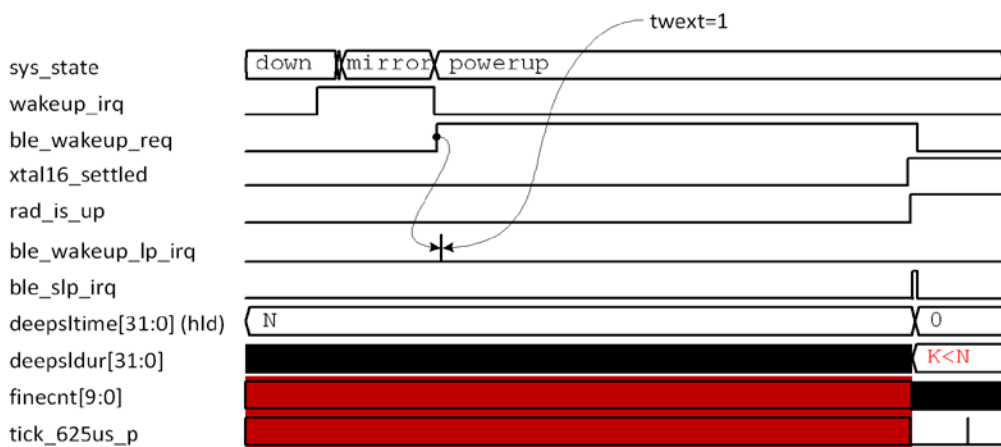

**Figure 70: Exit BLE Deep Sleep Mode Due to External Event**

As soon as the bit field BLE\_WAKEUP\_REQ is set to 1, the BLE\_WAKEUP\_LP\_IRQ will be asserted. In that case, the high period of BLE\_WAKEUP\_LP\_IRQ is controlled via TWEXT. The recommended value of TWEXT is "TWIRQ\_RESET + 1", meaning that BLE\_WAKEUP\_LP\_IRQ will remain high for one "ble\_lp\_clk" period.

As long as the BLE\_WAKEUP\_REQ is high, entering the sleep mode is prohibited. Please note that BLE\_WAKEUP\_REQ event can be disabled by setting BLE\_DEEPSLCTRL\_REG[EXTWKUPDSB].

## 30 Radio

### 30.1 Introduction

The Radio Transceiver implements the RF part of the BLE protocol. Together with the Bluetooth 5.1 PHY layer, it provides up to 93 dB RF link budget for a reliable wireless communication. All RF blocks are supplied by on-chip low-drop out-regulators (LDOs). The bias scheme is programmable per block and optimized for minimum power consumption. The radio block diagram is given in [Figure 71](#). It comprises the Receiver, Transmitter, Synthesizer, Rx/Tx combiner block, and Biasing LDOs.

#### Features

- Single ended RFIO interface, 50  $\Omega$  matched
- Alignment free operation
- -90 dBm receiver sensitivity
- Configurable transmit output power from -19.5 dBm up to +2.5 dBm
- Ultra-low power consumption
- Fast frequency tuning minimizes overhead

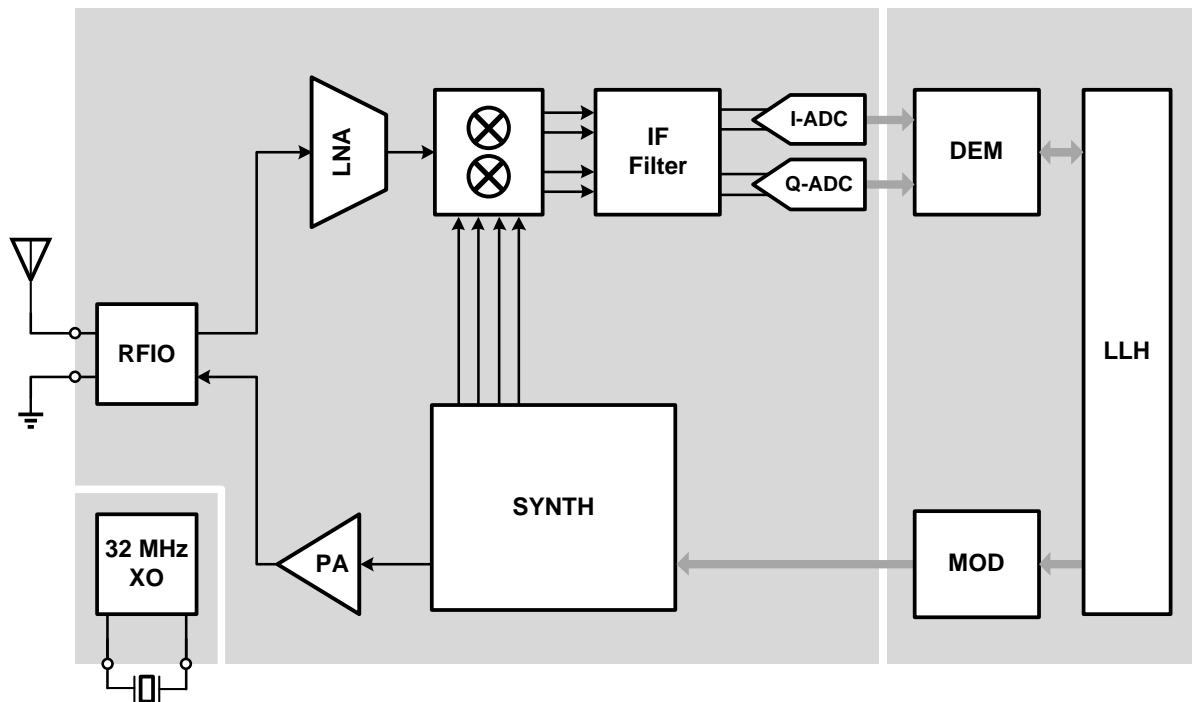

Figure 71: Bluetooth Radio Block Diagram

### 30.2 Architecture

#### 30.2.1 Receiver

The RX frontend consists of a selective matching network, a low noise amplifier (LNA), and an image rejection down conversion mixer. The intermediate frequency (IF) part of the receiver comprises a filter with a programmable gain. The LNA and IF Filter gains are controlled by the Automatic Gain Control (AGC). This provides the necessary signal conditioning prior to digitalization. The digital demodulator block (DEM) provides a synchronous bit stream.

### 30.2.2 Synthesizer

The RF Synthesizer generates the quadrature LO signal for the mixer, but also generates the modulated TX output signal. The Digitally Controlled Oscillator (DCO) runs at twice the required frequency and a dedicated divide-by-2 circuit generates the 2.4 GHz signals in the required phase relations. The reference frequency is the 32 MHz crystal clock. The modulation of the TX frequency is performed by 2-point modulation.

### 30.2.3 Transmitter

The RF power amplifier (RFPA) is an extremely efficient Class-D structure, providing typically the power ranging from -19.5 dBm to +2.5 dBm to the antenna. It is fed by the DCO's divide-by-2 circuit and delivers its TX power to the antenna pin through the combined RX/TX matching circuit.

### 30.2.4 RFIO

The RX/TX combiner block is a unique feature of the DA14530. It makes sure that the received power is applied to the LNA with minimum losses towards the RFPA. In TX mode, the LNA poses a minimal load for the RFPA and its input pins are protected from the RFPA. In both modes, the single ended RFIO port is matched to a resistor of 50  $\Omega$  in order to provide the simplest possible interfacing to the antenna on the printed circuit board.

### 30.2.5 Biasing

All RF blocks are supplied by on-chip LDOs. The bias scheme is programmable and optimized for minimum power consumption.

### 30.2.6 RF Monitoring

The Radio is equipped with a monitoring block whose responsibility is to acquire the data provided by the RF Unit and other analog resources, to combine them in words of 32 bits (when necessary), and to store them in system's memory. Data can be the output of the Demodulator (I and Q) or be provided by the GPADC. With the monitoring block, production tests of the corresponding block can be achieved.



## 31 Registers

This section contains a detailed view of the DA14530 registers. It is organized as follows: an overview table is presented initially, which depicts all register names, addresses, and descriptions. A detailed bit level description of each register follows.

The register file of the Arm Cortex-M0+ can be found in the following documents available on the website:

**Devices Generic User Guide:**

<https://developer.arm.com/docs/238818831/10/getting-started-with-cortex-m0-cortex-m0-cortex-m3-and-cortex-m4-full-licensee-bundles>

**Technical Reference Manual:**

<https://developer.arm.com/docs/ddi0484/c/preface>

These documents contain the register descriptions for the Nested Vectored Interrupt Controller (NVIC), the System Control Block (SCB), and the System Timer (SysTick).

Note that, any reference to DCDC converter (buck or boost) is not applicable and that VBAT\_LOW=VABT\_HIGH=VBAT (Battery voltage).

### 31.1 Analog Miscellaneous Registers

**Table 52: Register map anamisc2632\_bif\_00**

Address	Register	Description
0x50001600	CLK_REF_SEL_REG	Select clock for oscillator calibration
0x50001602	CLK_REF_CNT_REG	Count value for oscillator calibration
0x50001604	CLK_REF_VAL_L_REG	XTAL32M reference cycles, lower 16 bits
0x50001606	CLK_REF_VAL_H_REG	XTAL32M reference cycles, higher 16 bits

**Table 53: CLK\_REF\_SEL\_REG (0x50001600)**

Bit	Mode	Symbol	Description	Reset
3	R/W	EXT_CNT_EN_SEL	0 : Enable XTAL_CNT counter by the REF_CLK selected by REF_CLK_SEL. 1 : Enable XTAL_CNT counter from an external input.	0x0
2	R/W	REF_CAL_START	Writing a '1' starts a calibration of the clock selected by CLK_REF_SEL_REG[REF_CLK_SEL]. This bit is cleared when calibration is finished, and CLK_REF_VAL is ready.	0x0
1:0	R/W	REF_CLK_SEL	Select clock input for calibration: 0x0 : RC32K 0x1 : RC32M 0x2 : XTAL32K 0x3 : RCX	0x0

Table 54: CLK\_REF\_CNT\_REG (0x50001602)

Bit	Mode	Symbol	Description	Reset
15:0	R/W	REF_CNT_VAL	Indicates the calibration time, with a decrement counter to 1.	0x0

Table 55: CLK\_REF\_VAL\_L\_REG (0x50001604)

Bit	Mode	Symbol	Description	Reset
15:0	R	XTAL_CNT_VAL	Returns the number of DIVN clock cycles counted during the calibration time, defined with REF_CNT_VAL	0x0

Table 56: CLK\_REF\_VAL\_H\_REG (0x50001606)

Bit	Mode	Symbol	Description	Reset
15:0	R	XTAL_CNT_VAL	Returns the number of DIVN clock cycles counted during the calibration time, defined with REF_CNT_VAL	0x0

## 31.2 BLE Core Registers

**Table 57: Register map BLE**

Address	Register	Description
0x40000000	BLE_RWBLECNTRL_REG	BLE Control register
0x40000004	BLE_VERSION_REG	Version register
0x40000008	BLE_RWBLECONF_REG	Configuration register
0x4000000C	BLE_INTCNTL_REG	Interrupt controller register
0x40000010	BLE_INTSTAT_REG	Interrupt status register
0x40000014	BLE_INTRAWSTAT_REG	Interrupt raw status register
0x40000018	BLE_INTACK_REG	Interrupt acknowledge register
0x4000001C	BLE_BASETIMECNT_REG	Base time reference counter
0x40000020	BLE_FINETIMECNT_REG	Fine time reference counter
0x40000024	BLE_BDADDRL_REG	BLE device address LSB register
0x40000028	BLE_BDADDRU_REG	BLE device address MSB register
0x4000002C	BLE_CURRENTRXDESCPTR_REG	Rx Descriptor Pointer for the Receive Buffer Chained List
0x40000030	BLE_DEEPSLCNTL_REG	Deep-Sleep control register
0x40000034	BLE_DEEPSLWKUP_REG	Time (measured in Low Power clock cycles) in Deep Sleep Mode before waking-up the device
0x40000038	BLE_DEEPSLSTAT_REG	Duration of the last deep sleep phase register
0x4000003C	BLE_ENBPRESET_REG	Time in low power oscillator cycles register
0x40000040	BLE_FINECNTCORR_REG	Phase correction value register
0x40000044	BLE_BASETIMECNTCORR_REG	Base Time Counter
0x40000050	BLE_DIAGCNTL_REG	Diagnostics Register
0x40000054	BLE_DIAGSTAT_REG	Debug use only
0x40000058	BLE_DEBUGADDMAX_REG	Upper limit for the memory zone
0x4000005C	BLE_DEBUGADDMIN_REG	Lower limit for the memory zone
0x40000060	BLE_ERRORYPESTAT_REG	Error Type Status registers
0x40000064	BLE_SWPROFILING_REG	Software Profiling register
0x40000074	BLE_RADIOCNTRL1_REG	Radio interface control register

Address	Register	Description
0x40000080	BLE_RADIOPWUPDOWN_REG	RX/TX power up/down phase register
0x40000090	BLE_ADVCHMAP_REG	Advertising Channel Map
0x400000A0	BLE_ADVTIM_REG	Advertising Packet Interval
0x400000A4	BLE_ACTSCANSTAT_REG	Active scan register
0x400000B0	BLE_WLPUBADDPTR_REG	Start address of public devices list
0x400000B4	BLE_WLPRIVADDPTR_REG	Start address of private devices list
0x400000B8	BLE_WLNBDEV_REG	Devices in white list
0x400000C0	BLE_AESCNTL_REG	Start AES register
0x400000C4	BLE_AESKEY31_0_REG	AES encryption key
0x400000C8	BLE_AESKEY63_32_REG	AES encryption key
0x400000CC	BLE_AESKEY95_64_REG	AES encryption key
0x400000D0	BLE_AESKEY127_96_REG	AES encryption key
0x400000D4	BLE_AESPTR_REG	Pointer to the block to encrypt/decrypt
0x400000D8	BLE_TXMICVAL_REG	AES / CCM plain MIC value
0x400000DC	BLE_RXMICVAL_REG	AES / CCM plain MIC value
0x400000E0	BLE_RFTESTCNTL_REG	RF Testing Register
0x400000E4	BLE_RFTESTTXSTAT_REG	RF Testing Register
0x400000E8	BLE_RFTESTRXSTAT_REG	RF Testing Register
0x400000F0	BLE_TIMGENCNTL_REG	Timing Generator Register
0x400000F4	BLE_GROSSTIMTGT_REG	Gross Timer Target value
0x400000F8	BLE_FINETIMTGT_REG	Fine Timer Target value
0x400000FC	BLE_SAMPLECLK_REG	Samples the Base Time Counter
0x40000100	BLE_COEXIFCNTL0_REG	Coexistence interface Control 0 Register
0x40000104	BLE_COEXIFCNTL1_REG	Coexistence interface Control 1 Register
0x40000108	BLE_BLEMPRIO0_REG	Coexistence interface Priority 0 Register
0x4000010C	BLE_BLEMPRIO1_REG	Coexistence interface Priority 1 Register
0x40000200	BLE_CNTL2_REG	BLE Control Register 2

Address	Register	Description
0x40000208	BLE_EM_BASE_REG	Exchange Memory Base Register
0x4000020C	BLE_DIAGCNTL2_REG	Debug use only
0x40000210	BLE_DIAGCNTL3_REG	Debug use only

Table 58: BLE\_RWBLECNTL\_REG (0x40000000)

Bit	Mode	Symbol	Description	Reset
31	R0/W	MASTER_SOFT_RST	Reset the complete BLE Core except registers and timing generator, when written with a 1. Resets at 0 when action is performed. No action happens if it is written with 0.	0x0
30	R0/W	MASTER_TGSOFT_RST	Reset the timing generator, when written with a 1. Resets at 0 when action is performed. No action happens if it is written with 0.	0x0
29	R/W	REG_SOFT_RST	Reset the complete register block, when written with a 1. Resets at 0 when action is performed. No action happens if it is written with 0. Note that INT_STAT will not be cleared, so the user should also write to BLE_INTACK_REG after the SW Reset	0x0
28	R0/W	SWINT_REQ	Forces the generation of ble_sw_irq when written with a 1, and proper masking is set. Resets at 0 when action is performed. No action happens if it is written with 0.	0x0
26	R0/W	RFTEST_ABORT	Abort the current RF Testing defined as per CS-FORMAT when written with a 1. Resets at 0 when action is performed. No action happens if it is written with 0. Note that when RFTEST_ABORT is requested: 1) In case of infinite Tx, the Packet Controller FSM stops at the end of the current byte in process, and processes accordingly the packet CRC. 2) In case of Infinite Rx, the Packet Controller FSM either stops as the end of the current Packet reception (if Access address has been detected), or simply stop the processing switching off the RF.	0x0
25	R0/W	ADVERT_ABORT	Abort the current Advertising event when written with a 1. Resets at 0 when action is performed. No action happens if it is written with 0.	0x0
24	R0/W	SCAN_ABORT	Abort the current scan window when written with a 1. Resets at 0 when action is performed. No action happens if it is written with 0.	0x0
22	R/W	MD_DSB	0: Normal operation of MD bits management 1: Allow a single Tx/Rx exchange whatever the MD bits are. value forced by SW from Tx Descriptor value just saved in Rx Descriptor during reception	0x0
21	R/W	SN_DSB	0: Normal operation of Sequence number	0x0

Bit	Mode	Symbol	Description	Reset
			1: Sequence Number Management disabled: value forced by SW from Tx Descriptor value ignored in Rx, where no SN error reported.	
20	R/W	NESN_DSB	0: Normal operation of Acknowledge 1: Acknowledge scheme disabled: value forced by SW from Tx Descriptor value ignored in Rx, where no NESN error reported.	0x0
19	R/W	CRYPT_DSB	0: Normal operation. Encryption / Decryption enabled. 1: Encryption / Decryption disabled. Note that if CS-CRYPT_EN is set, then MIC is generated, and only data encryption is disabled, meaning data sent are plain data.	0x0
18	R/W	WHIT_DSB	0: Normal operation. Whitening enabled. 1: Whitening disabled.	0x0
17	R/W	CRC_DSB	0: Normal operation. CRC removed from data stream. 1: CRC stripping disabled on Rx packets, CRC replaced by 0x000 in Tx.	0x0
16	R/W	HOP_REMAP_DSB	0: Normal operation. Frequency Hopping Remapping algorithm enabled. 1: Frequency Hopping Remapping algorithm disabled	0x0
13:12	R/W	-		0x0
9	R/W	ADVERTFILT_EN	Advertising Channels Error Filtering Enable control 0: BLE Core reports all errors to RW-BLE Software 1: BLE Core reports only correctly received packet, without error to RW-BLE Software	0x0
8	R/W	RWBLE_EN	0: Disable BLE Core Exchange Table pre-fetch mechanism. 1: Enable BLE Core Exchange table pre-fetch mechanism.	0x0
7:4	R/W	RXWINSZDEF	Default Rx Window size in us. Used when device: is master connected performs its second receipt. 0 is not a valid value. Recommended value is 10 (in decimal).	0x0
2:0	R/W	SYNCERR	Indicates the maximum number of errors allowed to recognize the synchronization word.	0x0

Table 59: BLE\_VERSION\_REG (0x40000004)

Bit	Mode	Symbol	Description	Reset
31:24	R	TYP	BLE Core Type	0x7

Bit	Mode	Symbol	Description	Reset
23:16	R	REL	BLE Core version Major release number.	0x1
15:8	R	UPG	BLE Core upgrade Upgrade number.	0x0
7:0	R	BUILD	BLE Core Build Build number.	0x0

Table 60: BLE\_RWBLECONF\_REG (0x40000008)

Bit	Mode	Symbol	Description	Reset
29:24	R	ADD_WIDTH	Value of the RW_BLE_ADDRESS_WIDTH parameter concerted into binary.	0xF
22:16	R	RFIF	Radio Interface ID	0x2
13:8	R	CLK_SEL	Operating Frequency (in MHz)	0x0
6	R	DECIPHER	0: AES deciphering not present	0x0
5	R	DMMODE	0: BLE Core is used as a standalone BLE device	0x0
4	R	INTMODE	1: Interrupts are trigger level generated, i.e. stays active at 1 till acknowledgement	0x1
3	R	COEX	1: WLAN Coexistence mechanism present	0x1
2	R	USEDDBG	1: Diagnostic port instantiated	0x1
1	R	USECRYPT	1: AES-CCM Encryption block present	0x1
0	R	BUSWIDTH	Processor bus width: 1: 32 bits	0x1

Table 61: BLE\_INTCNTL\_REG (0x4000000C)

Bit	Mode	Symbol	Description	Reset
15	R/W	CSCNTDEVMSK	CSCNT interrupt mask during event. This bit allows to enable CSCNT interrupt generation during events (i.e. advertising, scanning, initiating, and connection) 0: CSCNT Interrupt not generated during events. 1: CSCNT Interrupt generated during events.	0x1
14:10	R	-		0x0
9	R/W	SWINTMSK	SW triggered interrupt Mask 0: Interrupt not generated 1: Interrupt generated	0x0
8	R/W	EVENTAPFAINTMSK	End of event / anticipated pre-fetch abort interrupt Mask 0: Interrupt not generated 1: Interrupt generated	0x1
7	R/W	FINETGTIMINTMSK	Fine Target Timer Mask 0: Interrupt not generated 1: Interrupt generated	0x0
6	R/W	GROSSTGTIMINTMSK	Gross Target Timer Mask 0: Interrupt not generated 1: Interrupt generated	0x0

Bit	Mode	Symbol	Description	Reset
5	R/W	ERRORINTMSK	Error Interrupt Mask 0: Interrupt not generated 1: Interrupt generated	0x0
4	R/W	CRYPTINTMSK	Encryption engine Interrupt Mask 0: Interrupt not generated 1: Interrupt generated	0x1
3	R/W	EVENTINTMSK	End of event Interrupt Mask 0: Interrupt not generated 1: Interrupt generated	0x1
2	R/W	SLPINTMSK	Sleep Mode Interrupt Mask 0: Interrupt not generated 1: Interrupt generated	0x1
1	R/W	RXINTMSK	Rx Interrupt Mask 0: Interrupt not generated 1: Interrupt generated	0x1
0	R/W	CSCNTINTMSK	625us Base Time Interrupt Mask 0: Interrupt not generated 1: Interrupt generated	0x1

Table 62: BLE\_INTSTAT\_REG (0x4000010)

Bit	Mode	Symbol	Description	Reset
9	R	SWINTSTAT	SW triggered interrupt status 0: No SW triggered interrupt. 1: A SW triggered interrupt is pending	0x0
8	R	EVENTAPFAINTSTAT	End of event / Anticipated Pre-Fetch Abort interrupt status 0: No End of Event interrupt. 1: An End of Event interrupt is pending.	0x0
7	R	FINETGTIMINTSTAT	Masked Fine Target Timer Error interrupt status 0: No Fine Target Timer interrupt. 1: A Fine Target Timer interrupt is pending.	0x0
6	R	GROSSTGTIMINTSTAT	Masked Gross Target Timer interrupt status 0: No Gross Target Timer interrupt. 1: A Gross Target Timer interrupt is pending.	0x0
5	R	ERRORINTSTAT	Masked Error interrupt status 0: No Error interrupt. 1: An Error interrupt is pending.	0x0
4	R	CRYPTINTSTAT	Masked Encryption engine interrupt status 0: No Encryption / Decryption interrupt. 1: An Encryption / Decryption interrupt is pending.	0x0
3	R	EVENTINTSTAT	Masked End of Event interrupt status 0: No End of Advertising / Scanning / Connection interrupt. 1: An End of Advertising / Scanning / Connection interrupt is pending.	0x0



Bit	Mode	Symbol	Description	Reset
2	R	SLPINTSTAT	Masked Sleep interrupt status 0: No End of Sleep Mode interrupt. 1: An End of Sleep Mode interrupt is pending.	0x0
1	R	RXINTSTAT	Masked Packet Reception interrupt status 0: No Rx interrupt. 1: An Rx interrupt is pending.	0x0
0	R	CSCNTINTSTAT	Masked 625us base time reference interrupt status 0: No 625us Base Time interrupt. 1: A 625us Base Time interrupt is pending.	0x0

Table 63: BLE\_INTRAWSTAT\_REG (0x4000014)

Bit	Mode	Symbol	Description	Reset
9	R	SWINTRAWSTAT	SW triggered interrupt raw status 0: No SW triggered interrupt. 1: A SW triggered interrupt is pending.	0x0
8	R	EVENTAPFAINTRA WSTAT	End of event / Anticipated Pre-Fetch Abort interrupt raw status 0: No End of Event interrupt. 1: An End of Event interrupt is pending.	0x0
7	R	FINETGTIMINTRA WSTAT	Fine Target Timer Error interrupt raw status 0: No Fine Target Timer interrupt. 1: A Fine Target Timer interrupt is pending.	0x0
6	R	GROSSTGTIMINTRA WSTAT	Gross Target Timer interrupt raw status 0: No Gross Target Timer interrupt. 1: A Gross Target Timer interrupt is pending.	0x0
5	R	ERRORINTRAWSTAT	Error interrupt raw status 0: No Error interrupt. 1: An Error interrupt is pending.	0x0
4	R	CRYPTINTRAWSTAT	Encryption engine interrupt raw status 0: No Encryption / Decryption interrupt. 1: An Encryption / Decryption interrupt is pending.	0x0
3	R	EVENTINTRAWSTAT	End of Event interrupt raw status 0: No End of Advertising / Scanning / Connection interrupt. 1: An End of Advertising / Scanning / Connection interrupt is pending.	0x0
2	R	SLPINTRAWSTAT	Sleep interrupt raw status 0: No End of Sleep Mode interrupt. 1: An End of Sleep Mode interrupt is pending.	0x0
1	R	RXINTRAWSTAT	Packet Reception interrupt raw status 0: No Rx interrupt. 1: An Rx interrupt is pending.	0x0
0	R	CSCNTINTRAWSTAT	625us base time reference interrupt raw status 0: No 625us Base Time interrupt.	0x0

Bit	Mode	Symbol	Description	Reset
			1: A 625us Base Time interrupt is pending.	

Table 64: BLE\_INTACK\_REG (0x40000018)

Bit	Mode	Symbol	Description	Reset
9	R0/W	SWINTACK	SW triggered interrupt acknowledgement bit Software writing 1 acknowledges the SW triggered interrupt. This bit resets SWINTSTAT and SWINTRAWSTAT flags. Resets at 0 when action is performed	0x0
8	R0/W	EVENTAPFAINTACK	End of event / Anticipated Pre-Fetch Abort interrupt acknowledgement bit Software writing 1 acknowledges the End of event / Anticipated Pre-Fetch Abort interrupt. This bit resets EVENTAPFAINTSTAT and EVENTAPFAINTRAWSTAT flags. Resets at 0 when action is performed	0x0
7	R0/W	FINETGTIMINTACK	Fine Target Timer interrupt acknowledgement bit Software writing 1 acknowledges the Fine Timer interrupt. This bit resets FINETGTIMINTSTAT and FINETGTIMINTRAWSTAT flags. Resets at 0 when action is performed	0x0
6	R0/W	GROSSTGTIMINTACK	Gross Target Timer interrupt acknowledgement bit Software writing 1 acknowledges the Gross Timer interrupt. This bit resets GROSSTGTIMINTSTAT and GROSSTGTIMINTRAWSTAT flags. Resets at 0 when action is performed	0x0
5	R0/W	ERRORINTACK	Error interrupt acknowledgement bit Software writing 1 acknowledges the Error interrupt. This bit resets ERRORINTSTAT and ERRORINTRAWSTAT flags. Resets at 0 when action is performed	0x0
4	R0/W	CRYPTINTACK	Encryption engine interrupt acknowledgement bit Software writing 1 acknowledges the Encryption engine interrupt. This bit resets CRYPTINTSTAT and CRYPTINTRAWSTAT flags. Resets at 0 when action is performed	0x0
3	R0/W	EVENTINTACK	End of Event interrupt acknowledgment bit Software writing 1 acknowledges the End of Advertising / Scanning / Connection interrupt. This bit resets SLPINTSTAT and SLPINTRAWSTAT flags. Resets at 0 when action is performed	0x0
2	R0/W	SLPINTACK	End of Deep Sleep interrupt acknowledgment bit Software writing 1 acknowledges the End of Sleep Mode interrupt. This bit resets SLPINTSTAT and SLPINTRAWSTAT flags. Resets at 0 when action is performed	0x0
1	R0/W	RXINTACK	Packet Reception interrupt acknowledgment bit	0x0

Bit	Mode	Symbol	Description	Reset
			Software writing 1 acknowledges the Rx interrupt. This bit resets RXINTSTAT and RXINTRAWSTAT flags. Resets at 0 when action is performed	
0	R0/W	CSCNTINTACK	625us base time reference interrupt acknowledgment bit Software writing 1 acknowledges the CLKN interrupt. This bit resets CLKINTSTAT and CLKINTRAWSTAT flags. Resets at 0 when action is performed	0x0

Table 65: BLE\_BASETIMECNT\_REG (0x4000001C)

Bit	Mode	Symbol	Description	Reset
26:0	R	BASETIMECNT	Value of the 625us base time reference counter. Updated each time SAMPCLK is written. Used by the SW in order to synchronize with the HW	0x0

Table 66: BLE\_FINETIMECNT\_REG (0x40000020)

Bit	Mode	Symbol	Description	Reset
9:0	R	FINECNT	Value of the current s fine time reference counter. Updated each time SAMPCLK is written. Used by the SW in order to synchronize with the HW, and obtain a more precise sleep duration	0x0

Table 67: BLE\_BDADDRL\_REG (0x40000024)

Bit	Mode	Symbol	Description	Reset
31:0	R/W	BDADDRL	Bluetooth Low Energy Device Address. LSB part.	0x0

Table 68: BLE\_BDADDRU\_REG (0x40000028)

Bit	Mode	Symbol	Description	Reset
16	R/W	PRIV_NPUB	Bluetooth Low Energy Device Address privacy indicator 0: Public Bluetooth Device Address 1: Private Bluetooth Device Address	0x0
15:0	R/W	BDADDRU	Bluetooth Low Energy Device Address. MSB part.	0x0

Table 69: BLE\_CURRENTRXDESCPTR\_REG (0x4000002C)

Bit	Mode	Symbol	Description	Reset
31:16	R/W	ETPTR	Exchange Table Pointer that determines the starting point of the Exchange Table	0x0

Bit	Mode	Symbol	Description	Reset
14:0	R/W	CURRENTRXDESCPTR	Rx Descriptor Pointer that determines the starting point of the Receive Buffer Chained List	0x0

Table 70: BLE\_DEEPSLCTL\_REG (0x40000030)

Bit	Mode	Symbol	Description	Reset
31	R/W	EXTWKUPDSB	External Wake-Up disable 0: RW-BLE Core can be woken by external wake-up 1: RW-BLE Core cannot be woken up by external wake-up	0x0
15	R	DEEP_SLEEP_STAT	Indicator of current Deep Sleep clock mux status: 0: RW-BLE Core is not yet in Deep Sleep Mode 1: RW-BLE Core is in Deep Sleep Mode (only low_power_clk is running)	0x0
4	R/W	SOFT_WAKEUP_REQ	Wake Up Request from BLE Software. Applies when system is in Deep Sleep Mode. It wakes up the BLE Core when written with a 1. Resets at 0 when action is performed. No action happens if it is written with 0.	0x0
3	R0/W	DEEP_SLEEP_CORR_EN	625us base time reference integer and fractional part correction. Applies when system has been woken-up from Deep Sleep Mode. It enables Fine Counter and Base Time counter when written with a 1. Resets at 0 when action is performed. No action happens if it is written with 0.	0x0
2	R0/W	DEEP_SLEEP_ON	0: BLE Core in normal active mode 1: Request RW-BLE Core to switch in deep sleep mode.  This bit is reset on DEEP_SLEEP_STAT falling edge.	0x0
1:0	R/W	DEEP_SLEEP_IRQ_EN	Always set to "3" when DEEP_SLEEP_ON is set to "1".  It controls the generation of BLE_WAKEUP_LP_IRQ.	0x0

Table 71: BLE\_DEEPSLWKUP\_REG (0x40000034)

Bit	Mode	Symbol	Description	Reset
31:0	R/W	DEEPSLTIME	Determines the time in low_power_clk clock cycles to spend in Deep Sleep Mode before waking-up the device. This ensures a maximum of 37 hours and 16mn sleep mode capabilities at 32kHz. This ensures a maximum of 36 hours and 16mn sleep mode capabilities at 32.768kHz	0x0

Table 72: BLE\_DEEPSLSTAT\_REG (0x40000038)

Bit	Mode	Symbol	Description	Reset
31:0	R	DEEPSLDUR	Actual duration of the last deep sleep phase measured in low_power_clk clock cycle. DEEPSLDUR is set to zero at the beginning of the deep sleep phase, and is incremented at each low_power_clk clock cycle until the end of the deep sleep phase.	0x0

Table 73: BLE\_ENBPRESET\_REG (0x4000003C)

Bit	Mode	Symbol	Description	Reset
31:21	R/W	TWEXT	Minimum and recommended value is "TWIRQ_RESET + 1". In the case of wake-up due to an external wake-up request, TWEXT specifies the time delay in low power oscillator cycles to deassert BLE_WAKEUP_LP_IRQ. Refer also to GP_CONTROL_REG[BLE_WAKEUP_REQ]. Range is [0...64 ms] for 32kHz; [0...62.5 ms] for 32.768kHz	0x0
20:10	R/W	TWIRQ_SET	Minimum value is "TWIRQ_RESET + 1". Time in low power oscillator cycles to set BLE_WAKEUP_LP_IRQ before the BLE sleep timer expiration. Refer also to BLE_DEEPSLWKUP_REG[DEEPSLTIME]. Range is [0...64 ms] for 32kHz; [0...62.5 ms] for 32.768kHz	0x0
9:0	R/W	TWIRQ_RESET	Recommended value is 1. Time in low power oscillator cycles to reset BLE_WAKEUP_LP_IRQ before the BLE sleep timer expiration. Refer also to BLE_DEEPSLWKUP_REG[DEEPSLTIME]. Range is [0...32 ms] for 32kHz; [0...31.25 ms] for 32.768kHz.	0x0

Table 74: BLE\_FINECNTCORR\_REG (0x40000040)

Bit	Mode	Symbol	Description	Reset
9:0	R/W	FINECNTCORR	Phase correction value for the 625us reference counter (i.e. Fine Counter) in us.	0x0

Table 75: BLE\_BASETIMECNTCORR\_REG (0x40000044)

Bit	Mode	Symbol	Description	Reset
26:0	R/W	BASETIMECNTCORR	Base Time Counter correction value.	0x0

**Table 76: BLE\_DIAGNTL\_REG (0x40000050)**

Bit	Mode	Symbol	Description	Reset
31	R/W	DIAG3_EN	0: Disable diagnostic port 0 output. All outputs are set to 0x0. 1: Enable diagnostic port 0 output.	0x0
29:24	R/W	DIAG3	Only relevant when DIAG3_EN = 1. Selection of the outputs that must be driven to the diagnostic port BLE_DIAG3.	0x0
23	R/W	DIAG2_EN	0: Disable diagnostic port 0 output. All outputs are set to 0x0. 1: Enable diagnostic port 0 output.	0x0
21:16	R/W	DIAG2	Only relevant when DIAG2_EN = 1. Selection of the outputs that must be driven to the diagnostic port BLE_DIAG2.	0x0
15	R/W	DIAG1_EN	0: Disable diagnostic port 0 output. All outputs are set to 0x0. 1: Enable diagnostic port 0 output.	0x0
13:8	R/W	DIAG1	Only relevant when DIAG1_EN = 1. Selection of the outputs that must be driven to the diagnostic port BLE_DIAG1.	0x0
7	R/W	DIAG0_EN	0: Disable diagnostic port 0 output. All outputs are set to 0x0. 1: Enable diagnostic port 0 output.	0x0
5:0	R/W	DIAG0	Only relevant when DIAG0_EN = 1. Selection of the outputs that must be driven to the diagnostic port BLE_DIAG0.	0x0

**Table 77: BLE\_DIAGSTAT\_REG (0x40000054)**

Bit	Mode	Symbol	Description	Reset
31:24	R	DIAG3STAT	Directly connected to ble_dbg3[7:0] output. Debug use only.	0x0
23:16	R	DIAG2STAT	Directly connected to ble_dbg2[7:0] output. Debug use only.	0x0
15:8	R	DIAG1STAT	Directly connected to ble_dbg1[7:0] output. Debug use only.	0x0
7:0	R	DIAG0STAT	Directly connected to ble_dbg0[7:0] output. Debug use only.	0x0

**Table 78: BLE\_DEBUGADDMAX\_REG (0x40000058)**

Bit	Mode	Symbol	Description	Reset
31:16	R/W	REG_ADDMAX	Upper limit for the Register zone indicated by the reg_inzone flag	0x0
15:0	R/W	EM_ADDMAX	Upper limit for the Exchange Memory zone indicated by the em_inzone flag	0x0

**Table 79: BLE\_DEBUGADMIN\_REG (0x4000005C)**

Bit	Mode	Symbol	Description	Reset
31:16	R/W	REG_ADDMIN	Lower limit for the Register zone indicated by the reg_inzone flag	0x0
15:0	R/W	EM_ADDMIN	Lower limit for the Exchange Memory zone indicated by the em_inzone flag	0x0

**Table 80: BLE\_ERRORYPESTAT\_REG (0x40000060)**

Bit	Mode	Symbol	Description	Reset
17	R	CONCEVTIRQ_ER ROR	Indicates whether two consecutive and concurrent ble_event_irq have been generated, and not acknowledged in time by the BLE Software. 0: No error 1: Error occurred	0x0
16	R	RXDATA_PTR_ER ROR	Indicates whether Rx data buffer pointer value programmed is null: this is a major programming failure. 0: No error 1: Error occurred	0x0
15	R	TXDATA_PTR_ERR OR	Indicates whether Tx data buffer pointer value programmed is null during Advertising / Scanning / Initiating events, or during Master / Slave connections with non-null packet length: this is a major programming failure. 0: No error 1: Error occurred	0x0
14	R	RXDESC_EMPTY_ ERROR	Indicates whether Rx Descriptor pointer value programmed in register is null: this is a major programming failure. 0: No error 1: Error occurred	0x0
13	R	TXDESC_EMPTY_ ERROR	Indicates whether Tx Descriptor pointer value programmed in Control Structure is null during Advertising / Scanning / Initiating events: this is a major programming failure. 0: No error 1: Error occurred	0x0
12	R	CSFORMAT_ERRO R	Indicates whether CS-FORMAT has been programmed with an invalid value: this is a major software programming failure. 0: No error 1: Error occurred	0x0
11	R	LLCHMAP_ERROR	Indicates Link Layer Channel Map error, happens when actual number of CS-LLCHMAP bit set to one is different from CS-NBCHGOOD at the beginning of Frequency Hopping process 0: No error 1: Error occurred	0x0

Bit	Mode	Symbol	Description	Reset
10	R	ADV_UNDERRUN	Indicates Advertising Interval Under run, occurs if time between two consecutive Advertising packet (in Advertising mode) is lower than the expected value. 0: No error 1: Error occurred	0x0
9	R	IFS_UNDERRUN	Indicates Inter Frame Space Under run, occurs if IFS time is not enough to update and read Control Structure/Descriptors, and/or White List parsing is not finished and/or Decryption time is too long to be finished on time 0: No error 1: Error occurred	0x0
8	R	WHITELIST_ERRO R	Indicates White List Timeout error, occurs if White List parsing is not finished on time 0: No error 1: Error occurred	0x0
7	R	EVT_CNTL_APFM_ ERROR	Indicates Anticipated Pre-Fetch Mechanism error: happens when 2 consecutive events are programmed, and when the first event is not completely finished while second pre-fetch instant is reached. 0: No error 1: Error occurred	0x0
6	R	EVT_SCHDL_APF M_ERROR	Indicates Anticipated Pre-Fetch Mechanism error: happens when 2 consecutive events are programmed, and when the first event is not completely finished while second pre-fetch instant is reached. 0: No error 1: Error occurred	0x0
5	R	EVT_SCHDL_ENTR Y_ERROR	Indicates Event Scheduler faced Invalid timing programing on two consecutive ET entries (e.g first one with 624s offset and second one with no offset) 0: No error 1: Error occurred	0x0
4	R	EVT_SCHDL_EMA CC_ERROR	Indicates Event Scheduler Exchange Memory access error, happens when Exchange Memory accesses are not served in time, and blocks the Exchange Table entry read 0: No error 1: Error occurred	0x0
3	R	RADIO_EMACC_E RROR	Indicates Radio Controller Exchange Memory access error, happens when Exchange Memory accesses are not served in time and data are corrupted. 0: No error 1: Error occurred	0x0
2	R	PKTCNTL_EMACC _ERROR	Indicates Packet Controller Exchange Memory access error, happens when Exchange Memory accesses are not served in time and Tx/Rx data are corrupted	0x0



Bit	Mode	Symbol	Description	Reset
			0: No error 1: Error occurred	
1	R	RXCRIPT_ERROR	Indicates real time decryption error, happens when AES-CCM decryption is too slow compared to Packet Controller requests. A 16-bytes block has to be decrypted prior the next block is received by the Packet Controller 0: No error 1: Error occurred	0x0
0	R	TXCRYPT_ERROR	Indicates Real Time encryption error, happens when AES-CCM encryption is too slow compared to Packet Controller requests. A 16-bytes block has to be encrypted and prepared on Packet Controller request, and needs to be ready before the Packet Controller has to send ti 0: No error 1: Error occurred	0x0

Table 81: BLE\_SWPROFILING\_REG (0x40000064)

Bit	Mode	Symbol	Description	Reset
31:0	R/W	SWPROFVAL	Software Profiling register: used by BLE Software for profiling purpose: this value is copied on Diagnostic port	0x0

Table 82: BLE\_RADIOCNTRL1\_REG (0x40000074)

Bit	Mode	Symbol	Description	Reset
31:21	-	-		0x0
20:16	R/W	XRFSEL	Extended radio selection field, Must be set to "2".	0x0

Table 83: BLE\_RADIOPWUPDN\_REG (0x40000080)

Bit	Mode	Symbol	Description	Reset
30:24	R/W	RTRIP_DELAY	Defines round trip delay value. This value correspond to the addition of data latency in Tx and data latency in Rx. Value is in usec.	0x0
23:16	R/W	RXPWRUP	This register holds the length in s of the RX power up phase for the current radio device. Default value is 210 usec (reset value). Operating range depends on the selected radio.	0xD2
11:8	R/W	TXPWRDN	This register extends the length in s of the TX power down phase for the current radio device. Default value is 3 usec (reset value). Operating range depends on the selected radio.	0x3

Bit	Mode	Symbol	Description	Reset
7:0	R/W	TXPWRUP	This register holds the length in s of the TX power up phase for the current radio device. Default value is 210 usec (reset value). Operating range depends on the selected radio.	0xD2

Table 84: BLE\_ADVCHMAP\_REG (0x40000090)

Bit	Mode	Symbol	Description	Reset
2:0	R/W	ADVCHMAP	Advertising Channel Map, defined as per the advertising connection settings. Contains advertising channels index 37 to 39. If ADVCHMAP[i] equals: 0: Do not use data channel i+37. 1: Use data channel i+37.	0x7

Table 85: BLE\_ADVTIM\_REG (0x400000A0)

Bit	Mode	Symbol	Description	Reset
13:0	R/W	ADVINT	Advertising Packet Interval defines the time interval in between two ADV_XXX packet sent. Value is in us. Value to program depends on the used Advertising Packet type and the device filtering policy.	0x0

Table 86: BLE\_ACTSCANSTAT\_REG (0x400000A4)

Bit	Mode	Symbol	Description	Reset
24:16	R	BACKOFF	Active scan mode back-off counter initialization value.	0x1
8:0	R	UPPERLIMIT	Active scan mode upper limit counter value.	0x1

Table 87: BLE\_WLPUBADDPTR\_REG (0x400000B0)

Bit	Mode	Symbol	Description	Reset
15:0	R/W	WLPUBADDPTR	Start address pointer of the public devices white list.	0x0

Table 88: BLE\_WLPRIVADDPTR\_REG (0x400000B4)

Bit	Mode	Symbol	Description	Reset
15:0	R/W	WLPRIVADDPTR	Start address pointer of the private devices white list.	0x0

**Table 89: BLE\_WLNBDEV\_REG (0x400000B8)**

Bit	Mode	Symbol	Description	Reset
15:8	R/W	NBPRIVDEV	Number of private devices in the white list.	0x0
7:0	R/W	NBPUBDEV	Number of public devices in the white list.	0x0

**Table 90: BLE\_AESCNTL\_REG (0x400000C0)**

Bit	Mode	Symbol	Description	Reset
1	R/W	AES_MODE	0: Cipher mode 1: Decipher mode	0x0
0	R0/W	AES_START	Writing a 1 starts AES-128 ciphering/deciphering process. This bit is reset once the process is finished (i.e. ble_crypt_irq interrupt occurs, even masked)	0x0

**Table 91: BLE\_AESKEY31\_0\_REG (0x400000C4)**

Bit	Mode	Symbol	Description	Reset
31:0	R/W	AESKEY31_0	AES encryption 128-bit key. Bit 31 down to 0	0x0

**Table 92: BLE\_AESKEY63\_32\_REG (0x400000C8)**

Bit	Mode	Symbol	Description	Reset
31:0	R/W	AESKEY63_32	AES encryption 128-bit key. Bit 63 down to 32	0x0

**Table 93: BLE\_AESKEY95\_64\_REG (0x400000CC)**

Bit	Mode	Symbol	Description	Reset
31:0	R/W	AESKEY95_64	AES encryption 128-bit key. Bit 95 down to 64	0x0

**Table 94: BLE\_AESKEY127\_96\_REG (0x400000D0)**

Bit	Mode	Symbol	Description	Reset
31:0	R/W	AESKEY127_96	AES encryption 128-bit key. Bit 127 down to 96	0x0

**Table 95: BLE\_AESPTR\_REG (0x400000D4)**

Bit	Mode	Symbol	Description	Reset
15:0	R/W	AESPTR	Pointer to the memory zone where the block to cipher/decipher using AES-128 is stored.	0x0

Table 96: BLE\_TXMICVAL\_REG (0x400000D8)

Bit	Mode	Symbol	Description	Reset
31:0	R	TXMICVAL	AES-CCM plain MIC value. Valid on when MIC has been calculated (in Tx)	0x0

Table 97: BLE\_RXMICVAL\_REG (0x400000DC)

Bit	Mode	Symbol	Description	Reset
31:0	R	RXMICVAL	AES-CCM plain MIC value. Valid on once MIC has been extracted from Rx packet.	0x0

Table 98: BLE\_RFTESTCNTL\_REG (0x400000E0)

Bit	Mode	Symbol	Description	Reset
31	R/W	INFINITERX	Applicable in RF Test Mode only 0: Normal mode of operation 1: Infinite Rx window	0x0
27	R/W	RXPKTCNTEN	Applicable in RF Test Mode only 0: Rx packet count disabled 1: Rx packet count enabled, and reported in CS-RXCCMPKTCNT and BLE_RFTESTRXSTAT_REG[RXPKTCNT] on RF abort command	0x0
15	R/W	INFINITETX	Applicable in RF Test Mode only 0: Normal mode of operation. 1: Infinite Tx packet / Normal start of a packet but endless payload	0x0
14	R/W	TXLENGTHSRC	Applicable only in Tx/Rx RF Test mode 0: Normal mode of operation: TxDESC-TXADVLEN controls the Tx packet payload size 1: Uses BLE_RFTESTCNTL_REG[TXLENGTH] packet length (can support up to 512 bytes transmit)	0x0
13	R/W	PRBSTYPE	Applicable only in Tx/Rx RF Test mode 0: Tx Packet Payload are PRBS9 type 1: Tx Packet Payload are PRBS15 type	0x0
12	R/W	TXPLDSRC	Applicable only in Tx/Rx RF Test mode 0: Tx Packet Payload source is the Control Structure 1: Tx Packet Payload are PRBS generator	0x0
11	R/W	TXPKTCNTEN	Applicable in RF Test Mode only 0: Tx packet count disabled 1: Tx packet count enabled, and reported in CS-TXCCMPKTCNT and BLE_RFTESTTXSTAT_REG[TXPKTCNT] on RF abort command	0x0
8:0	R/W	TXLENGTH	Applicable only for Tx/Rx RF Test mode, and valid when BLE_RFTESTCNTL_REG[TXLENGTHSRC] = 1	0x0

Bit	Mode	Symbol	Description	Reset
			Tx packet length in number of byte	

Table 99: BLE\_RFTESTTXSTAT\_REG (0x40000E4)

Bit	Mode	Symbol	Description	Reset
31:0	R	TXPKTCNT	Reports number of transmitted packet during Test Modes. Value is valid if BLE_RFTESTCNTL_REG[TXPKTCNTEN] is set	0x0

Table 100: BLE\_RFTESTRXSTAT\_REG (0x40000E8)

Bit	Mode	Symbol	Description	Reset
31:0	R	RXPKTCNT	Reports number of correctly received packet during Test Modes (no sync error, no CRC error). Value is valid if BLE_RFTESTCNTL_REG[RXPKTCNTEN] is set	0x0

Table 101: BLE\_TIMGENCNTL\_REG (0x40000F0)

Bit	Mode	Symbol	Description	Reset
31	R/W	APFM_EN	Controls the Anticipated pre-Fetch Abort mechanism 0: Disabled 1: Enabled	0x1
25:16	R/W	PREFETCHABORT_TIME	Defines the instant in usec at which immediate abort is required after anticipated pre-fetch abort.	0x1FE
8:0	R/W	PREFETCH_TIME	Defines Exchange Table pre-fetch instant in us	0x96

Table 102: BLE\_GROSSTIMTGT\_REG (0x40000F4)

Bit	Mode	Symbol	Description	Reset
22:0	R/W	GROSSTARGET	Gross Timer Target value on which a ble_grosstgtim_irq must be generated. This timer has a precision of 10ms: interrupt is generated only when GROSSTARGET[22:0] = BASETIMECNT[26:4] and BASETIMECNT[3:0] = 0.	0x0

Table 103: BLE\_FINETIMTGT\_REG (0x40000F8)

Bit	Mode	Symbol	Description	Reset
26:0	R/W	FINETARGET	Fine Timer Target value on which a ble_finetgtim_irq must be generated. This timer has a precision of 625 usec: interrupt is generated only when FINETARGET = BASETIMECNT	0x0

Table 104: BLE\_SAMPLECLK\_REG (0x400000FC)

Bit	Mode	Symbol	Description	Reset
31:1	-	-		0x0
0	R0/W	SAMP	Writing a 1 samples the Base Time Counter value in BASETIMECNT register. Resets at 0 when action is performed.	0x0

Table 105: BLE\_COEXIFCNTLO\_REG (0x40000100)

Bit	Mode	Symbol	Description	Reset
21:20	R/W	WLCRXPRIOMODE	Defines Bluetooth Low Energy packet ble_rx mode behavior. 00: Rx indication excluding Rx Power up delay (starts when correlator is enabled) 01: Rx indication including Rx Power up delay 10: Rx High priority indicator 11: n/a	0x0
17:16	R/W	WLCTXPRIOMODE	Defines Bluetooth Low Energy packet ble_tx mode behavior 00: Tx indication excluding Tx Power up delay 01: Tx indication including Tx Power up delay 10: Tx High priority indicator 11: n/a	0x0
7:6	R/W	WLANTXMSK	Determines how wlan_tx impact BLE Tx and Rx 00: wlan_tx has no impact (default mode) 01: wlan_tx can stop BLE Tx, no impact on BLE Rx 10: wlan_tx can stop BLE Rx, no impact on BLE Tx 11: wlan_tx can stop both BLE Tx and BLE Rx	0x0
5:4	R/W	WLANRXMSK	Determines how wlan_rx impact BLE Tx and Rx 00: wlan_rx has no impact 01: wlan_rx can stop BLE Tx, no impact on BLE Rx (default mode) 10: wlan_rx can stop BLE Rx, no impact on BLE Tx 11: wlan_rx can stop both BLE Tx and BLE Rx	0x1
1	R/W	SYNCGEN_EN	Determines whether ble_sync is generated or not. 0: ble_sync pulse not generated 1: ble_sync pulse generated	0x0
0	R/W	COEX_EN	Enable / Disable control of the MWS/WLAN Coexistence control 0: Coexistence interface disabled 1: Coexistence interface enabled	0x0

Table 106: BLE\_COEXIFCNTL1\_REG (0x40000104)

Bit	Mode	Symbol	Description	Reset
28:24	R/W	WLCPRXTHR	Applies on ble_rx if WLCRXPRIOMODE equals 10 Determines the threshold for Rx priority setting. If ble_pti[3:0] output value is greater than WLCPRXTHR, then Rx Bluetooth Low Energy priority is considered as high, and must be provided to the WLAN coexistence interface	0x0
20:16	R/W	WLCPTXTHR	Applies on ble_tx if WLCTXPRIOMODE equals 10 Determines the threshold for priority setting. If ble_pti[3:0] output value is greater than WLCPTXTHR, then Tx Bluetooth Low Energy priority is considered as high, and must be provided to the WLAN coexistence interface	0x0
14:8	R/W	WLCPDURATION	Applies on ble_tx if WLCTXPRIOMODE equals 10 Applies on ble_rx if WLCRXPRIOMODE equals 10 Determines how many s the priority information must be maintained Note that if WLCPDURATION = 0x00, then Tx/Rx priority levels are maintained till Tx/Rx EN are de-asserted.	0x0
6:0	R/W	WLCPDELAY	Applies on ble_tx if WLCTXPRIOMODE equals 10. Applies on ble_rx if WLCRXPRIOMODE equals 10. Determines the delay (in us) in Tx/Rx enables rises the time Bluetooth Low energy Tx/Rx priority has to be provided .	0x0

Table 107: BLE\_BLEMPRIO0\_REG (0x40000108)

Bit	Mode	Symbol	Description	Reset
31:28	R/W	BLEM7	Set Priority value for Passive Scanning	0x3
27:24	R/W	BLEM6	Set Priority value for Non-Connectable Advertising	0x4
23:20	R/W	BLEM5	Set Priority value for Connectable Advertising BLE message	0x8
19:16	R/W	BLEM4	Set Priority value for Active Scanning BLE message	0x9
15:12	R/W	BLEM3	Set Priority value for Initiating (Scanning) BLE message	0xA
11:8	R/W	BLEM2	Set Priority value for Data Channel transmission BLE message	0xD
7:4	R/W	BLEM1	Set Priority value for LLCP BLE message	0xE
3:0	R/W	BLEM0	Set Priority value for Initiating (Connection Request Response) BLE message	0xF

Table 108: BLE\_BLEMPRIO1\_REG (0x4000010C)

Bit	Mode	Symbol	Description	Reset
31:28	R/W	BLEMDEFAULT	Set default priority value for other BLE message than those defined above	0x3

Table 109: BLE\_CNTL2\_REG (0x40000200)

Bit	Mode	Symbol	Description	Reset
31:25	R	-		0x0
24	R/W	BLE_PHY_ERR_MSK_N		0x0
23	R/W	BLE_ARP_ERR_MSK_N	When cleared to "0" then it masks the BLE_ARP_ERR_STAT in order to not trigger a BLE_ERROR_IRQ.	0x0
22	RW1C	BLE_ARP_PHY_ERR_STAT	When set to "1" then an error occurred in BLE ARP sub-block and the BLE_GEN_IRQ will be asserted. It will be set if the ARP_ERROR or PHY_ERROR will be asserted and if the BLE_ARP_ERR_MSK is set to "1". Writing the value "1" will acknowledge and clear this field.	0x0
21	R/W	BLE_RSSI_SEL	0: (default) Select Peak-hold RSSI value during the SYNC_FOUND event: CS->RXRSSI[7:0] = RF_RSSI_RESULT_REG->RSSI_LATCHED_RD[9:2]. 1: Select the Average RSSI value during the SYNC_FOUND event: CS->RXRSSI[7:0] = RF_RSSI_RESULT_REG->RSSI_AVG_RD[9:2].	0x0
20	R	WAKEUPLPSTAT	The status of the BLE_WAKEUP_LP_IRQ. The Interrupt Service Routine of BLE_WAKEUP_LP_IRQ should return only when the WAKEUPLPSTAT is cleared. Note that BLE_WAKEUP_LP_IRQ is automatically acknowledged after the power up of the Radio Subsystem, plus one Low Power Clock period.	0x0
19	R/W	SW_RPL_SPI	Keep to 0.	0x0
18	R/W	BB_ONLY	Keep to 0.	0x0
17	R/W	BLE_PTI_SOURCE_SEL	0: Provide to COEX block the PTI value indicated by the Control Structure. Recommended value is "0". 1: Provide to COEX block the PTI value generated dynamically by the BLE core, which is based on the PTI of the Control Structure.	0x0
16:15	R	-		0x0
14:9	R/W	BLE_CLK_SEL	BLE Clock Select. Specifies the BLE master clock absolute frequency in MHz. Typical values are 16 and 8. Value depends on the selected XTAL frequency and the value of CLK_RADIO_REG[BLE_DIV]	0x0



Bit	Mode	Symbol	Description	Reset
			<p>bitfield. For example, if XTAL oscillates at 16MHz and CLK_RADIO_REG[BLE_DIV] = 1 (divide by 2), then BLE master clock frequency is 8MHz and BLE_CLK_SEL should be set to value 8.</p> <p>The selected BLE master clock frequency (affected by BLE_DIV and BLE_CLK_SEL) must be modified and set only during the initialization time, i.e. before setting BLE_RWBLECNTRL_REG[RWBLE_EN] to 1.</p> <p>Refer also to BLE_RWBLECONF_REG[CLK_SEL].</p>	
8	R	RADIO_PWRDN_ALLOW	<p>This active high signal indicates when it is allowed for the BLE core (embedded in the Radio sub-System power domain) to be powered down.</p> <p>After the assertion of the BLE_DEEPSLCNTL_REG[DEEP_SLEEP_ON] a hardware sequence based on the Low Power clock will cause the assertion of RADIO_PWRDN_ALLOW. The RADIO_PWRDN_ALLOW will be cleared to "0" when the BLE core exits from the sleep state, i.e. when the BLE_SLP_IRQ will be asserted.</p>	0x0
7	R	MON_LP_CLK	<p>The SW can only write a "0" to this bit.</p> <p>Whenever a positive edge of the low power clock used by the BLE Timers is detected, then the HW will automatically set this bit to "1". This functionality will not work if BLE Timer is in reset state (refer to CLK_RADIO_REG[BLE_LP_RESET]).</p> <p>This bit can be used for SW synchronization, to debug the low power clock, etc.</p>	0x0
6	R	BLE_CLK_STAT	<p>0: BLE uses low power clock 1: BLE uses master clock</p>	0x0
5:4	R/W	-		0x0
3	R/W	BLE_DIAG_OVR	<p>1: Overrule BLE_DIAG. 0: BLE_DIAG is not overruled.</p>	0x0
2	R/W	EMACCERRMSK	<p>Exchange Memory Access Error Mask: When cleared to "0" the EM_ACC_ERR will not cause an BLE_ERROR_IRQ interrupt. When set to "1" an BLE_ERROR_IRQ will be generated as long as EM_ACC_ERR is "1".</p>	0x1
1	R0/W	EMACCERRACK	<p>Exchange Memory Access Error Acknowledge. When the SW writes a "1" to this bit then the EMACCERRSTAT bit will be cleared. When the SW writes "0" it will have no affect. The read value is always "0".</p>	0x0
0	R	EMACCERRSTAT	<p>Exchange Memory Access Error Status: The bit is read-only and can be cleared only by writing a "1" at EMACCERRACK bitfield. This bit will be set to "1" by the hardware when the controller will access an EM page that is not mapped according to the EM_MAPPING value.</p>	0x0

Bit	Mode	Symbol	Description	Reset
			When this bit is "1" then the BLE_ERROR_IRQ will be asserted as long as EMACCERRMSK is "1".	

Table 110: BLE\_EM\_BASE\_REG (0x40000208)

Bit	Mode	Symbol	Description	Reset
31:17	R	-		0x0
16:10	R/W	BLE_EM_BASE_16_10	The physical address on the system memory map of the base of the Exchange Memory.	0x0
9:0	R	-		0x0

Table 111: BLE\_DIAGNTL2\_REG (0x4000020C)

Bit	Mode	Symbol	Description	Reset
31	R/W	DIAG7_EN	0: Disable diagnostic port 0 output. All outputs are set to 0x0. 1: Enable diagnostic port 0 output.	0x0
30	R	-		0x0
29:24	R/W	DIAG7	Only relevant when DIAG7_EN = 1. Selection of the outputs that must be driven to the diagnostic port BLE_DIAG7.	0x0
23	R/W	DIAG6_EN	0: Disable diagnostic port 0 output. All outputs are set to 0x0. 1: Enable diagnostic port 0 output.	0x0
22	R	-		0x0
21:16	R/W	DIAG6	Only relevant when DIAG6_EN = 1. Selection of the outputs that must be driven to the diagnostic port BLE_DIAG6.	0x0
15	R/W	DIAG5_EN	0: Disable diagnostic port 0 output. All outputs are set to 0x0. 1: Enable diagnostic port 0 output.	0x0
14	R	-		0x0
13:8	R/W	DIAG5	Only relevant when DIAG5_EN= 1. Selection of the outputs that must be driven to the diagnostic port BLE_DIAG5.	0x0
7	R/W	DIAG4_EN	0: Disable diagnostic port 0 output. All outputs are set to 0x0. 1: Enable diagnostic port 0 output.	0x0
6	R	-		0x0
5:0	R/W	DIAG4	Only relevant when DIAG4_EN = 1. Selection of the outputs that must be driven to the diagnostic port BLE_DIAG4.	0x0

Table 112: BLE\_DIAGCNTL3\_REG (0x40000210)

Bit	Mode	Symbol	Description	Reset
31	R/W	DIAG7_INV	If set, then the specific diagnostic bit will be inverted.	0x0
30:28	R/W	DIAG7_BIT	Selects which bit from the DIAG7 word will be forwarded to bit 7 of the BLE Diagnostic Port.	0x0
27	R/W	DIAG6_INV	If set, then the specific diagnostic bit will be inverted.	0x0
26:24	R/W	DIAG6_BIT	Selects which bit from the DIAG6 word will be forwarded to bit 6 of the BLE Diagnostic Port.	0x0
23	R/W	DIAG5_INV	If set, then the specific diagnostic bit will be inverted.	0x0
22:20	R/W	DIAG5_BIT	Selects which bit from the DIAG5 word will be forwarded to bit 5 of the BLE Diagnostic Port.	0x0
19	R/W	DIAG4_INV	If set, then the specific diagnostic bit will be inverted.	0x0
18:16	R/W	DIAG4_BIT	Selects which bit from the DIAG4 word will be forwarded to bit 4 of the BLE Diagnostic Port.	0x0
15	R/W	DIAG3_INV	If set, then the specific diagnostic bit will be inverted.	0x0
14:12	R/W	DIAG3_BIT	Selects which bit from the DIAG3 word will be forwarded to bit 3 of the BLE Diagnostic Port.	0x0
11	R/W	DIAG2_INV	If set, then the specific diagnostic bit will be inverted.	0x0
10:8	R/W	DIAG2_BIT	Selects which bit from the DIAG2 word will be forwarded to bit 2 of the BLE Diagnostic Port.	0x0
7	R/W	DIAG1_INV	If set, then the specific diagnostic bit will be inverted.	0x0
6:4	R/W	DIAG1_BIT	Selects which bit from the DIAG1 word will be forwarded to bit 1 of the BLE Diagnostic Port.	0x0
3	R/W	DIAG0_INV	If set, then the specific diagnostic bit will be inverted.	0x0
2:0	R/W	DIAG0_BIT	Selects which bit from the DIAG0 word will be forwarded to bit 0 of the BLE Diagnostic Port.	0x0

### 31.3 Clock Generation and Reset Registers

**Table 113: Register map CRG**

Address	Register	Description
0x50000000	CLK_AMBA_REG	HCLK, PCLK, divider and clock gates
0x50000002	CLK_FREQ_TRIM_REG	Xtal frequency trimming register
0x50000004	CLK_PER_REG	Peripheral divider register
0x50000008	CLK_RADIO_REG	Radio PLL control register
0x5000000A	CLK_CTRL_REG	Clock control register
0x50000010	PMU_CTRL_REG	Power Management Unit control register
0x50000012	SYS_CTRL_REG	System Control register
0x50000014	SYS_STAT_REG	System status register
0x50000016	TRIM_CTRL_REG	Control trimming of the XTAL32M
0x50000018	RAM_PWR_CTRL_REG	Control power state of System RAMS
0x50000020	CLK_RC32K_REG	32 kHz RC oscillator register
0x50000022	CLK_XTAL32K_REG	32 kHz XTAL oscillator register
0x50000024	CLK_RC32M_REG	Fast RC control register
0x50000026	CLK_RCX_REG	RCX-oscillator control register
0x50000028	BANDGAP_REG	Bandgap trimming
0x5000002A	ANA_STATUS_REG	Status bit of analog (power management) circuits
0x50000030	XTAL32M_START_REG	Trim values for XTAL32M
0x50000032	XTAL32M_TRSTAT_REG	Read back value of current XTAL trimming
0x50000034	XTALRDY_CTRL_REG	Control register for XTALRDY IRQ
0x50000038	XTAL32M_CTRL0_REG	Control bits for XTAL32M
0x50000040	POR_PIN_REG	Selects a GPIO pin for POR generation
0x50000042	POR_TIMER_REG	Time for POR to happen
0x50000050	PMU_SLEEP_REG	Bandgap refresh interval during sleep
0x50000052	POWER_CTRL_REG	Power management control
0x50000054	POWER_LEVEL_REG	Power management level and trim settings

**Table 114: CLK\_AMBA\_REG (0x50000000)**

Bit	Mode	Symbol	Description	Reset
7	R/W	OTP_ENABLE	Clock enable for OTP controller	0x0
6	R/W	-		0x0

Bit	Mode	Symbol	Description	Reset
5:4	R/W	PCLK_DIV	APB interface clock (PCLK). Divider is cascaded with HCLK_DIV. PCLK is HCLK divided by: 0x0: divide by 1 0x1: divide by 2 0x2: divide by 4 0x3: divide by 8	0x0
3:2	R/W	-		0x0
1:0	R/W	HCLK_DIV	AHB interface and microprocessor clock (HCLK). HCLK is source clock divided by: 0x0: divide by 1 0x1: divide by 2 0x2: divide by 4 0x3: divide by 8	0x0

Table 115: CLK\_FREQ\_TRIM\_REG (0x50000002)

Bit	Mode	Symbol	Description	Reset
7:0	R/W	XTAL32M_TRIM	Xtal frequency fine trimming register. 0x00: highest frequency 0xFF: lowest frequency	0x80

Table 116: CLK\_PER\_REG (0x50000004)

Bit	Mode	Symbol	Description	Reset
11	R/W	QUAD_ENABLE	Enable the Quadrature clock	0x1
10	R/W	SPI_ENABLE	Enable SPI clock	0x0
9:8	R/W	-		0x0
7	R/W	UART1_ENABLE	Enable UART1 clock	0x0
6	R/W	UART2_ENABLE	Enable UART2 clock	0x0
5	R/W	I2C_ENABLE	Enable I2C clock	0x0
4	R/W	WAKEUPCT_ENABLE	Enable Wakeup CaptureTimer clock	0x0
3	R/W	TMR_ENABLE	Enable TIMER0 and TIMER2 clock	0x0
2	R/W	-		0x0
1:0	R/W	TMR_DIV	Division factor for TIMER0 0x0: divide by 1 0x1: divide by 2 0x2: divide by 4 0x3: divide by 8	0x0

Table 117: CLK\_RADIO\_REG (0x50000008)

Bit	Mode	Symbol	Description	Reset
15:8	-	-		0x0
7	R/W	BLE_ENABLE	Enable the BLE core clocks	0x0
6	R/W	BLE_LP_RESET	Reset for the BLE LP timer	0x1
5:4	R/W	BLE_DIV	Division factor for BLE core blocks 0x0: divide by 1 0x1: divide by 2 0x2: divide by 4 0x3: divide by 8  The programmed frequency should not be lower than 8 MHz and not faster than the programmed CPU clock frequency. Refer also to BLE_CNTL2_REG[BLE_CLK_SEL].	0x0
3	R/W	RFCU_ENABLE	Enable the RF control Unit clock	0x0
2	R/W	-		0x0
1:0	R/W	-		0x0

Table 118: CLK\_CTRL\_REG (0x5000000A)

Bit	Mode	Symbol	Description	Reset
7	R	RUNNING_AT_XTAL32M	Indicates that the XTAL32M clock is used as clock, and may not be switched off	0x0
6	R	RUNNING_AT_RC32M	Indicates that the RC32M clock is used as clock	0x1
5	R	RUNNING_AT_LP_CLK	Indicates that either the LP_CLK is being used as system clock	0x0
4:3	R/W	LP_CLK_SEL	Sets the clock source of the LowerPower clock 0x0: RC32K 0x1: RCX 0x2: XTAL32K through the oscillator with an external Crystal. 0x3: XTAL32K through an external square wave generator (set PID of P0[3] to FUNC_GPIO) Change this setting before using this clock, and while RUNNING_AT_LP_CLK == 0.	0x0
2	R/W	XTAL32M_DISABLE	Setting this bit instantaneously disables the 32 MHz crystal oscillator. Also, after sleep/wakeup cycle, the oscillator will not be enabled. This bit may not be set to '1' when "RUNNING_AT_XTAL32M is '1' to prevent deadlock. After resetting this bit, wait for XTAL32M_SETTLED or XTAL32M_TRIM_READY to become '1' before switching to XTAL32M clock source.	0x0
1:0	R/W	SYS_CLK_SEL	Selects the clock source. 0x0: XTAL32M (check the XTAL32M_SETTLED and XTAL32M_TRIM_READY bits!!) 0x1: RC32M 0x2/0x3: LP_CLK	0x1

Table 119: PMU\_CTRL\_REG (0x50000010)

Bit	Mode	Symbol	Description	Reset
6	R/W	MAP_BANDGAP_EN	Enable wakeup diagnostics mapping. When set, these functions are mapped (please set direction to output) P0[2]: BANDGAP_ENABLE P0[1]: Power WOKENUP Note: P0[2] assigned also to SWD_CLK, thus the debugger must be detached before entering into sleep mode with MAP_BANDGAP_EN=1. Refer also to SYS_STAT_REG->DBG_IS_UP.	0x0
5:4	R/W	OTP_COPY_DIV	Sets the HCLK division during OTP mirroring	0x0
3	R/W	-		0x0
2	R/W	RADIO_SLEEP	Put the digital part of the radio in powerdown	0x1
1	R/W	TIM_SLEEP	Put PD_TIM in powerdown	0x1
0	R/W	RESET_ON_WAKEUP	Perform a Hardware Reset after waking up. Booter will be started.	0x0

Table 120: SYS\_CTRL\_REG (0x50000012)

Bit	Mode	Symbol	Description	Reset
15	W	SW_RESET	Writing a '1' to this bit will reset the device, except for: SYS_CTRL_REG CLK_FREQ_TRIM_REG ...	0x0
10	R/W	TIMEOUT_DISABLE	Disables timeout in Power statemachine. By default, the statemachine continues if after 2 ms the blocks are not started up. This can be read back from ANA_STATUS_REG.	0x0
9	R/W	-		0x0
8:7	R/W	DEBUGGER_ENABLE	Enable the debugger. This bit is set by the booter according to the OTP header. If not set, the SWDIO and SW_CLK can be used as gpio ports. 0x0: no debugger enabled. 0x1: SW_CLK = P0[2], SW_DIO=P0[5] 0x2: SW_CLK = P0[2], SW_DIO=P0[1] 0x3: SW_CLK = P0[2], SW_DIO=P0[10]	0x0
6	R/W	OTPC_RESET_REQ	Reset request for the OTP controller.	0x0
5	R/W	-		0x1
4	R/W	OTP_COPY	Enables OTP to SysRAM copy action after waking up PD_SYS	0x0
3	R/W	-		0x0
2	R/W	DEV_PHASE	Sets the development phase mode.	0x0

Bit	Mode	Symbol	Description	Reset
			<p>If this bit is set, in combination with the OTP_COPY bit, the OTP DMA will emulate the OTP mirroring to System RAM.</p> <p>No actual writing to RAM is done, but the exact same amount of time is spend as if the mirroring would take place. This is to mimic the behavior as if the System Code is already in OTP, and the mirroring takes place after waking up, but the (development) code still resides in an external source.</p> <p>If this bit is set to '0' and OTP_COPY='1', then the OTP DMA will actually do the OTP mirroring at wakeup.</p>	
1:0	R/W	REMAP_ADR0	<p>Controls which memory is located at address 0x0000 for execution.</p> <p>0x0: ROM 0x1: OTP 0x2: RAM (SysRAM1) 0x3: RAM (SysRAM3, 28 kBytes offset)</p> <p>This bitfield only takes affect after a Software Reset.</p>	0x0

Table 121: **SYS\_STAT\_REG (0x50000014)**

Bit	Mode	Symbol	Description	Reset
7	R	XTAL32M_SETTLE_D	Indicates that XTAL32M has had its settle time, as defined by TRIM_CTRL_REG[XTAL_SETTLE_N]	0x0
6	R	XTAL32M_TRIM_READY	Indicates that XTAL trimming mechanism is ready, i.e. the trimming equals CLK_FREQ_TRIM_REG.	0x1
5	R	-		0x0
4	R	DBG_IS_UP	Indicates that the SW debugger is attached and in connection with the Cortex.	0x0
3	R	TIM_IS_UP	Indicates that PD_TIM is functional	0x0
2	R	TIM_IS_DOWN	Indicates that PD_TIM is in power down	0x1
1	R	RAD_IS_UP	Indicates that PD_RAD is functional	0x0
0	R	RAD_IS_DOWN	Indicates that PD_RAD is in power down	0x1

Table 122: **TRIM\_CTRL\_REG (0x50000016)**

Bit	Mode	Symbol	Description	Reset
13:8	R/W	XTAL_SETTLE_N	Designates that the XTAL can be safely used as the CPU clock. When XTAL_CLK_CNT reaches this value, the signal XTAL32M_SETTLED bit in the SYS_STAT_REG will be set. Counts in steps of 64 xtal clock-cycles.	0x3F
7:6	R/W	XTAL_TRIM_SELECT	<p>Select which source controls the XTAL trimming</p> <p>0b00: xtal counter. Starts XTAL32M_START_REG[XTAL32M_START] after</p>	0x0



Bit	Mode	Symbol	Description	Reset
			<p>COUNT_N * 32 xtal pulses trim is changed to CLK_FREQ_TRIM_REG[XTAL32M_TRIM].</p> <p>0b01: xtal OK filter. Starts with CLK_FREQ_TRIM_REG[XTAL32M_START], when xtal amplitude is ramping is changed to CLK_FREQ_TRIM_REG[XTAL32M_TRIM].</p> <p>0b10: statically forced off. Only uses CLK_FREQ_TRIM_REG[XTAL32M_TRIM].</p> <p>0b11: xtal OK filter, 2 stage. Starts with CLK_FREQ_TRIM_REG[XTAL32M_START] switches to CLK_FREQ_TRIM_REG[XTAL32M_RAMP] after timeout (32us), and switches to CLK_FREQ_TRIM_REG[XTAL32M_TRIM] when xtal amplitude is ramping up.</p>	
5:0	R/W	XTAL_COUNT_N	<p>Defines the number of XTAL cycles to be counted, before the xtal trimming is applied, in steps of 64 cycles.</p> <p>0x01: 64 0x02: 128 0x3f: 4032</p>	0x22

Table 123: RAM\_PWR\_CTRL\_REG (0x50000018)

Bit	Mode	Symbol	Description	Reset
5:4	R/W	RAM3_PWR_CTRL	See description of RAM1_PWR_CTRL.	0x0
3:2	R/W	RAM2_PWR_CTRL	See description of RAM1_PWR_CTRL.	0x0
1:0	R/W	RAM1_PWR_CTRL	<p>Power state control of the individual RAMs. May only change when the memory isn't accessed.</p> <p>When in Active or Sleep mode:</p> <p>0x0: Normal operation 0x1: Normal operation 0x2: Retained (no access possible) 0x3: Off (memory content corrupted)</p> <p>When in Extended Sleep, Deep Sleep or Hibernation mode</p> <p>0x0: Retained 0x1: Off (memory content corrupted) 0x2: Retained 0x3: Off (memory content corrupted)</p>	0x0

Table 124: CLK\_RC32K\_REG (0x50000020)

Bit	Mode	Symbol	Description	Reset
4:1	R/W	RC32K_TRIM	<p>0000 = lowest frequency 0111 = default 1111 = highest frequency</p>	0x7
0	R/W	RC32K_DISABLE	Instantly disables the 32kHz RC oscillator	0x0

Bit	Mode	Symbol	Description	Reset
			Sleep cycles cannot happen with this clock disabled.	

Table 125: CLK\_XTAL32K\_REG (0x50000022)

Bit	Mode	Symbol	Description	Reset
8	-	-		0x0
7	R/W	XTAL32K_DISABLE_AMPREG	Setting this bit disables the amplitude regulation of the XTAL32kHz oscillator. Set this bit to '1' for an external clock to XTAL32Kp Keep this bit '0' with a crystal between XTAL32Kp and XTAL32Km	0x0
6:3	R/W	XTAL32K_CUR	Bias current for the 32kHz XTAL oscillator. 0000 is minimum, 1111 is maximum, 0011 is default. For each application there is an optimal setting for which the start-up behavior is optimal	0x5
2:1	R/W	XTAL32K_RBIAS	Setting for the bias resistor. 00 is maximum, 11 is minimum. Preferred setting will be provided by Dialog	0x3
0	R/W	XTAL32K_ENABLE	Enables the 32kHz XTAL oscillator. Also set GP_DATA_REG[P03_P04_FILT_DIS] = 1 for lowest current consumption.	0x0

Table 126: CLK\_RC32M\_REG (0x50000024)

Bit	Mode	Symbol	Description	Reset
10:7	R/W	RC32M_COSC	C-adjust of RC-oscillator A higher value of COSC results in a lower frequency	0xF
6:5	R/W	RC32M_RANGE	Coarse adjust A higher value of RANGE results in a higher frequency, values 2 and 3 are equal	0x0
4:1	R/W	RC32M_BIAS	Bias adjustment	0x7
0	R/W	RC32M_DISABLE	Instantly disables the 32MHz RC oscillator Disabling of the oscillator during sleep happens automatically.	0x0

Table 127: CLK\_RCX\_REG (0x50000026)

Bit	Mode	Symbol	Description	Reset
11:8	R/W	RCX_BIAS	LDO bias current. 0x0: minimum 0xF: maximum	0xA
7	R/W	RCX_C0	Add unit capacitance to RC-time delay.	0x1
6:2	R/W	RCX_CADJUST	Adjust capacitance part of RC-time delay.	0x1F

Bit	Mode	Symbol	Description	Reset
			0x00: minimum capacitance 0x1F: maximum capacitance	
1	R/W	RCX_RADJUST	Adjust resistance part of RC-time delay. Lower resistance increases power consumption. 0x0: maximum resistance 0x1: minimum resistance	0x0
0	R/W	RCX_ENABLE	Enable the RCX oscillator	0x0

Table 128: **BANDGAP\_REG (0x50000028)**

Bit	Mode	Symbol	Description	Reset
9:5	R/W	BGR_ITRIM	Trim setting for bandgap bias current 10000 -> -25% .... 11111 -> ~0% 00000 -> ~0% (typ) ... 01111 -> +32%	0x0
4:0	R/W	BGR_TRIM	Trim setting for bandgap voltage 10000 -> -6.4% .... 11111 -> ~0% 00000 -> ~0% (typ) ... 01111 -> +5.8%	0x0

Table 129: **ANA\_STATUS\_REG (0x5000002A)**

Bit	Mode	Symbol	Description	Reset
12	R	CLKLESS_WAKEUP_STAT	Indicates the output of the Clockless wakeup XOR tree. If this signal is '0', the chip will wake up. Use the HIBERN_WKUP_POLARITY bit to set the value to '1' before going into hibernation mode.	0x0
11	-	-		0x0
10	R	LDO_GPADC_OK	Indicates that LDO_GPADC output is OK	0x0
9	R	LDO_XTAL_OK	Indicates that LDO_XTAL output is OK	0x0
8	R	BOOST_SELECTED	0: Buck mode detected 1: Boost mode detected	0x0
7	R	POR_VBAT_HIGH	Output of V <sub>BAT_HIGH</sub> supply rail voltage monitoring circuit. 0: Voltage level on V <sub>BAT_HIGH</sub> is lower than POR VBAT_HIGH threshold V <sub>TH_L</sub> (rail not ok, will result in reset if not masked) 1: Voltage level on V <sub>BAT_HIGH</sub> is higher than POR VBAT_HIGH threshold V <sub>TH_H</sub> (rail ok, reset released)	0x0

Bit	Mode	Symbol	Description	Reset
6	R	POR_VBAT_LOW	Output of V <sub>BAT_LOW</sub> supply rail voltage monitoring circuit. 0: Voltage level on V <sub>BAT_LOW</sub> is lower than POR VBAT_LOW threshold V <sub>TH_L</sub> (rail not ok, will result in reset if not masked) 1: Voltage level on V <sub>BAT_LOW</sub> is higher than POR VBAT_LOW threshold V <sub>TH_H</sub> (rail ok, reset released)	0x0
5	R	BANDGAP_OK	Indicates that BANDGAP is OK	0x0
4	R	COMP_VBAT_HIG H_NOK	Indicates that V <sub>BAT_HIGH</sub> < V <sub>BAT_LOW</sub> -50 mV	0x0
3	R	COMP_VBAT_HIG H_OK	Indicates that V <sub>BAT_HIGH</sub> > V <sub>BAT_LOW</sub> +50 mV	0x0
2	R	DCDC_OK	Indicates that V <sub>BAT_LOW</sub> (buck mode) or V <sub>BAT_HIGH</sub> (boost mode) is OK	0x0
1	R	LDO_LOW_OK	Indicates that LDO_LOW output is OK (only valid for high current mode)	0x0
0	R	LDO_CORE_OK	Indicates that LDO_CORE output is OK	0x0

Table 130: XTAL32M\_START\_REG (0x50000030)

Bit	Mode	Symbol	Description	Reset
15:8	R/W	XTAL32M_RAMP	Xtal frequency trimming register. 0x00 : highest frequency 0xFF : lowest frequency	0x0
7:0	R/W	XTAL32M_START	Xtal frequency trimming register. 0x0 = highest frequency 0xF = lowest frequency.	0xAA

Table 131: XTALRDY\_CTRL\_REG (0x50000034)

Bit	Mode	Symbol	Description	Reset
7:0	R/W	XTALRDY_CNT	Number of 32kHz cycles between the crystal is enabled, and the XTALRDY_IRQ is fired. 0x00: no interrupt	0x0

Table 132: XTAL32M\_CTRL0\_REG (0x50000038)

Bit	Mode	Symbol	Description	Reset
9:8	-	-		0x0
7:5	R/W	CORE_AMPL_TRIM	Core amplitude trimming	0x0
4:2	R/W	CORE_CUR_SET	Core current trim setting	0x5
1	R/W	CORE_AMPL_REG _NULLBIAS	Keep bias in ampl detector alive, even when there is a large drive	0x0

Bit	Mode	Symbol	Description	Reset
0	R/W	DCBLOCK_ENABLE	Enable dcblock/high pass filter circuit	0x1

Table 133: **POR\_PIN\_REG (0x50000040)**

Bit	Mode	Symbol	Description	Reset
7	R/W	POR_PIN_POLARITY	0: Active Low 1: Active High Note: This applies only for the GPIO pin. Reset pad has a fixed polarity	0x0
6:4	R/W	-		0x0
3:0	R/W	POR_PIN_SELECT	Selects the GPIO which is used for POR generation. 0x0: GPIO pin POReset disabled 0x1: P0_0 0x2: P0_1 ... 0xB: P0_10 0xC: P0_11 0xD - 0xF: reserved	0x0

Table 134: **POR\_TIMER\_REG (0x50000042)**

Bit	Mode	Symbol	Description	Reset
6:0	R/W	POR_TIME	Time for the POReset to happen. Formula: Time = POR_TIME x 4096 x RC32k clock period Default value: ~3 seconds When set to 0x00, the POR TIMER is disabled.	0x18

Table 135: **PMU\_SLEEP\_REG (0x50000050)**

Bit	Mode	Symbol	Description	Reset
11:0	R/W	BG_REFRESH_INTERVAL	Defines the refresh interval of reference voltages (bandgap activation and sampling), in units of 2ms.	0x80

Table 136: **POWER\_CTRL\_REG (0x50000052)**

Bit	Mode	Symbol	Description	Reset
15	R/W	VBAT_HL_CONNECT_MODE	Sets the control mode fo the switch between VBAT_HIGH and VBAT_LOW 0: Manual (default) 1: Automatic (boost mode only)	0x0

Bit	Mode	Symbol	Description	Reset
14	R/W	POR_VBAT_HIGH_HYST_DIS	0: Hysteresis enabled 1: Hysteresis disabled	0x1
13	R/W	POR_VBAT_HIGH_HYST_SEL	0: Low level selected 1: High level selected	0x0
12	R/W	POR_VBAT_HIGH_DISABLE	Disable por_vbat_high circuit	0x0
11	R/W	POR_VBAT_LOW_HYST_DIS	0: Hysteresis enabled 1: Hysteresis disabled	0x0
10	R/W	POR_VBAT_LOW_HYST_SEL	0: Low level selected 1: High level selected	0x0
9	R/W	POR_VBAT_LOW_DISABLE	Disable por_vbat_low circuit	0x0
8	R/W	CP_DISABLE	Disables LDO_CORE charge-pump circuit	0x0
7	R/W	LDO_VREF_HOLD_FORCE	Forces LDO references in HOLD mode	0x0
6:5	R/W	LDO_LOW_CTRL_REG	00: High-current mode in active, LDO_LOW OFF in sleep 01: LDO_LOW OFF 10: Low-current mode in active, Low-current mode in sleep 11: High-current mode in active, Low-current mode in sleep	0x0
4	R/W	LDO_CORE_DISABLE	Disables LDO_CORE	0x0
3	R/W	LDO_CORE_RET_ENABLE	LDO_CORE_RETENTION 0: Disabled 1: Enabled	0x0
2	R/W	VBAT_HL_CONNECT	Switch between V <sub>BAT_HIGH</sub> and V <sub>BAT_LOW</sub> 0: Open 1: Closed	0x0
1	R/W	CMP_VBAT_HIGH_OK_ENABLE	Enable cmp_vbat_high_ok	0x0
0	R/W	CMP_VBAT_HIGH_NOK_ENABLE	Enable cmp_vbat_high_nok	0x0

Table 137: POWER\_LEVEL\_REG (0x50000054)

Bit	Mode	Symbol	Description	Reset
13:11	R/W	DCDC_TRIM	Delta from DCDC_LEVEL nominal value 000: -75 mV 001: -50 mV 010: -25 mV 011: 0 (default) 100: +25 mV 101: +50 mV 110: +75 mV	0x3

Bit	Mode	Symbol	Description	Reset
			111: +100 mV	
10:9	R/W	DCDC_LEVEL	00: 1.1 V 01: 1.8 V (default) 10: 2.5 V 11: 3.0 V	0x1
8:7	-	-		0x0
6:4	R/W	LDO_XTAL_TRIM	Delta from 0.9 V nominal value 000: -75 mV 001: -50 mV 010: -25 mV 011: 0 (default) 100: +25 mV 101: +50 mV 110: +75 mV 111: +100 mV	0x3
3:1	R/W	LDO_LOW_TRIM	Delta from 1.1 V nominal value 000: -75 mV 001: -50 mV 010: -25 mV 011: 0 (default) 100: +25 mV 101: +50 mV 110: +75 mV 111: +100 mV (coldboot)	0x7
0	-	-		0x0

Table 138: XTAL32M\_TRSTAT\_REG (0x50000032)

Bit	Mode	Symbol	Description	Reset
7:0	R	XTAL32M_TRSTAT	Reads value of the current XTAL trimming	0x0

Table 139: Register map crg2632\_preg\_tim\_00

Address	Register	Description
0x5000424C	CLK_RTCDIV_REG	Divisor for RTC 100Hz clock

Table 140: CLK\_RTCDIV\_REG (0x5000424C)

Bit	Mode	Symbol	Description	Reset
21	R/W	RTC_RESET_REQ	Reset request for the RTC module	0x0
20	R/W	RTC_DIV_ENABLE	Enable for the 100 Hz generation for the RTC block	0x0
19	R/W	RTC_DIV_DENOM	Selects the denominator for the fractional division: 0b0: 1000 0b1: 1024	0x0

Bit	Mode	Symbol	Description	Reset
18:10	R/W	RTC_DIV_INT	Integer divisor part for RTC 100Hz generation	0x147
9:0	R/W	RTC_DIV_FRAC	Fractional divisor part for RTC 100Hz generation. if RTC_DIV_DENOM=1, <RTC_DIV_FRAC> out of 1024 cycles will divide by <RTC_DIV_INT+1>, the rest is <RTC_DIV_INT> If RTC_DIV_DENOM=0, <RTC_DIV_FRAC> out of 1000 cycles will divide by <RTC_DIV_INT+1>, the rest is <RTC_DIV_INT>	0x2A8



### 31.4 DMA Controller Registers

**Table 141: Register map DMA**

Address	Register	Description
0x50003600	DMA0_A_STARTL_REG	Start address Low A of DMA channel 0
0x50003602	DMA0_A_STARTH_REG	Start address High A of DMA channel 0
0x50003604	DMA0_B_STARTL_REG	Start address Low B of DMA channel 0
0x50003606	DMA0_B_STARTH_REG	Start address High B of DMA channel 0
0x50003608	DMA0_INT_REG	DMA receive interrupt register channel 0
0x5000360A	DMA0_LEN_REG	DMA receive length register channel 0
0x5000360C	DMA0_CTRL_REG	Control register for the DMA channel 0
0x5000360E	DMA0_IDX_REG	Index value of DMA channel 0
0x50003610	DMA1_A_STARTL_REG	Start address Low A of DMA channel 1
0x50003612	DMA1_A_STARTH_REG	Start address High A of DMA channel 1
0x50003614	DMA1_B_STARTL_REG	Start address Low B of DMA channel 1
0x50003616	DMA1_B_STARTH_REG	Start address High B of DMA channel 1
0x50003618	DMA1_INT_REG	DMA receive interrupt register channel 1
0x5000361A	DMA1_LEN_REG	DMA receive length register channel 1
0x5000361C	DMA1_CTRL_REG	Control register for the DMA channel 1
0x5000361E	DMA1_IDX_REG	Index value of DMA channel 1
0x50003620	DMA2_A_STARTL_REG	Start address Low A of DMA channel 2
0x50003622	DMA2_A_STARTH_REG	Start address High A of DMA channel 2
0x50003624	DMA2_B_STARTL_REG	Start address Low B of DMA channel 2
0x50003626	DMA2_B_STARTH_REG	Start address High B of DMA channel 2
0x50003628	DMA2_INT_REG	DMA receive interrupt register channel 2
0x5000362A	DMA2_LEN_REG	DMA receive length register channel 2
0x5000362C	DMA2_CTRL_REG	Control register for the DMA channel 2
0x5000362E	DMA2_IDX_REG	Index value of DMA channel 2
0x50003630	DMA3_A_STARTL_REG	Start address Low A of DMA channel 3
0x50003632	DMA3_A_STARTH_REG	Start address High A of DMA channel 3

Address	Register	Description
0x50003634	DMA3_B_STARTL_REG	Start address Low B of DMA channel 3
0x50003636	DMA3_B_STARTH_REG	Start address High B of DMA channel 3
0x50003638	DMA3_INT_REG	DMA receive interrupt register channel 3
0x5000363A	DMA3_LEN_REG	DMA receive length register channel 3
0x5000363C	DMA3_CTRL_REG	Control register for the DMA channel 3
0x5000363E	DMA3_IDX_REG	Index value of DMA channel 3
0x50003680	DMA_REQ_MUX_REG	DMA channel assignments
0x50003682	DMA_INT_STATUS_REG	DMA interrupt status register
0x50003684	DMA_CLEAR_INT_REG	DMA clear interrupt register

Table 142: DMA0\_A\_STARTL\_REG (0x50003600)

Bit	Mode	Symbol	Description	Reset
15:0	R/W	DMA0_A_STARTL	Source start address, lower 16 bits	0x0

Table 143: DMA0\_A\_STARTH\_REG (0x50003602)

Bit	Mode	Symbol	Description	Reset
15:0	R/W	DMA0_A_STARTH	Source start address, upper 16 bits	0x0

Table 144: DMA0\_B\_STARTL\_REG (0x50003604)

Bit	Mode	Symbol	Description	Reset
15:0	R/W	DMA0_B_STARTL	Destination start address, lower 16 bits	0x0

Table 145: DMA0\_B\_STARTH\_REG (0x50003606)

Bit	Mode	Symbol	Description	Reset
15:0	R/W	DMA0_B_STARTH	Destination start address, upper 16 bits	0x0

Table 146: DMA0\_INT\_REG (0x50003608)

Bit	Mode	Symbol	Description	Reset
15:0	R/W	DMA0_INT	Number of transfers until an interrupt is generated. The interrupt is generated after a transfer, if DMAx_INT_REG is equal to DMAx_IDX_REG and before DMAx_IDX_REG is incremented. The bit-	0x0

Bit	Mode	Symbol	Description	Reset
			field IRQ_ENABLE of DMAx_CTRL_REG must be set to '1' to let the controller generate the interrupt.	

Table 147: DMA0\_LEN\_REG (0x5000360A)

Bit	Mode	Symbol	Description	Reset
15:0	R/W	DMA0_LEN	DMA channel's transfer length. DMAx_LEN of value 0, 1, 2, ... results into an actual transfer length of 1, 2, 3, ...	0x0

Table 148: DMA0\_CTRL\_REG (0x5000360C)

Bit	Mode	Symbol	Description	Reset
15:14	R	-		0x0
13	R/W	REQ_SENSE	0 = DMA operates with level-sensitive peripheral requests (default) 1 = DMA operates with (positive) edge-sensitive peripheral requests	0x0
12	R/W	DMA_INIT	0 = DMA performs copy A1 to B1, A2 to B2, etc ... 1 = DMA performs copy of A1 to B1, B2, etc ... This feature is useful for memory initialization to any value. Thus, BINC must be set to '1', while AINC is don't care, as only one fetch from A is done. This process cannot be interrupted by other DMA channels. It is also noted that DMA_INIT should not be used when DREQ_MODE='1'.	0x0
11	R/W	DMA_IDLE	0 = Blocking mode, the DMA performs a fast back-to-back copy, disabling bus access for any bus master with lower priority. 1 = Interrupting mode, the DMA inserts a wait cycle after each store allowing the CPU to steal cycles or cache to perform a burst read. If DREQ_MODE='1', DMA_IDLE is don't care.	0x0
10:8	R/W	DMA_PRIO	The priority level determines which DMA channel will be granted access for transferring data, in case more than one channels are active and request the bus at the same time. The greater the value, the higher the priority. In specific: 000 = lowest priority 111 = highest priority If different channels with equal priority level values request the bus at the same time, an inherent priority mechanism is applied. According to this mechanism, if, for example, both the DMA0 and DMA1 channels have the same priority level, then DMA0 will first be granted access to the bus.	0x0
7	R/W	CIRCULAR	0 = Normal mode. The DMA channel stops after having completed the transfer of length determined by DMAx_LEN_REG. DMA_ON automatically deasserts when the transfer is completed.	0x0

Bit	Mode	Symbol	Description	Reset
			1 = Circular mode (applicable only if DREQ_MODE = '1'). In this mode, DMA_ON never deasserts, as the DMA channel automatically resets DMAx_IDX_REG and starts a new transfer.	
6	R/W	AINC	Enable increment of source address. 0 = do not increment (source address stays the same during the transfer) 1 = increment according to the value of BW bit-field (by 1, when BW="00" ; by 2, when BW="01" ; by 4, when BW="10")	0x0
5	R/W	BINC	Enable increment of destination address. 0 = do not increment (destination address stays the same during the transfer) 1 = increment according to the value of BW bit-field (by 1, when BW="00" ; by 2, when BW="01" ; by 4, when BW="10")	0x0
4	R/W	DREQ_MODE	0 = DMA channel starts immediately 1 = DMA channel must be triggered by peripheral DMA request (see also the description of DMA_REQ_MUX_REG)	0x0
3	R/W	IRQ_ENABLE	0 = disable interrupt on this channel 1 = enable interrupt on this channel	0x0
2:1	R/W	BW	Bus transfer width: 00 = 1 Byte (suggested for peripherals like UART and 8-bit SPI) 01 = 2 Bytes (suggested for peripherals like I2C and 16-bit SPI) 10 = 4 Bytes (suggested for Memory-to-Memory transfers) 11 = Reserved	0x0
0	R/W	DMA_ON	0 = DMA channel is off, clocks are disabled 1 = DMA channel is enabled. This bit will be automatically cleared after the completion of a transfer, if circular mode is not enabled. In circular mode, this bit stays set.	0x0

Table 149: DMA0\_IDX\_REG (0x5000360E)

Bit	Mode	Symbol	Description	Reset
15:0	R	DMA0_IDX	This (read-only) register determines the data items currently fetched by the DMA channel, during an on-going transfer. When the transfer is completed, the register is automatically reset to 0.  The DMA channel uses this register to form the source/destination address of the next DMA cycle, considering also AINC/BINC and BW.	0x0

Table 150: DMA1\_A\_STARTL\_REG (0x50003610)

Bit	Mode	Symbol	Description	Reset
15:0	R/W	DMA1_A_STARTL	Source start address, lower 16 bits	0x0

Table 151: DMA1\_A\_STARTH\_REG (0x50003612)

Bit	Mode	Symbol	Description	Reset
15:0	R/W	DMA1_A_STARTH	Source start address, upper 16 bits	0x0

Table 152: DMA1\_B\_STARTL\_REG (0x50003614)

Bit	Mode	Symbol	Description	Reset
15:0	R/W	DMA1_B_STARTL	Destination start address, lower 16 bits	0x0

Table 153: DMA1\_B\_STARTH\_REG (0x50003616)

Bit	Mode	Symbol	Description	Reset
15:0	R/W	DMA1_B_STARTH	Destination start address, upper 16 bits	0x0

Table 154: DMA1\_INT\_REG (0x50003618)

Bit	Mode	Symbol	Description	Reset
15:0	R/W	DMA1_INT	Number of transfers until an interrupt is generated. The interrupt is generated after a transfer, if DMAx_INT_REG is equal to DMAx_IDX_REG and before DMAx_IDX_REG is incremented. The bit-field IRQ_ENABLE of DMAx_CTRL_REG must be set to '1' to let the controller generate the interrupt.	0x0

Table 155: DMA1\_LEN\_REG (0x5000361A)

Bit	Mode	Symbol	Description	Reset
15:0	R/W	DMA1_LEN	DMA channel's transfer length. DMAx_LEN of value 0, 1, 2, ... results into an actual transfer length of 1, 2, 3, ...	0x0

Table 156: DMA1\_CTRL\_REG (0x5000361C)

Bit	Mode	Symbol	Description	Reset
15:14	R	-		0x0
13	R/W	REQ_SENSE	0 = DMA operates with level-sensitive peripheral requests (default) 1 = DMA operates with (positive) edge-sensitive peripheral requests	0x0

Bit	Mode	Symbol	Description	Reset
12	R/W	DMA_INIT	<p>0 = DMA performs copy A1 to B1, A2 to B2, etc ...</p> <p>1 = DMA performs copy of A1 to B1, B2, etc ...</p> <p>This feature is useful for memory initialization to any value. Thus, BINC must be set to '1', while AINC is don't care, as only one fetch from A is done. This process cannot be interrupted by other DMA channels. It is also noted that DMA_INIT should not be used when DREQ_MODE='1'.</p>	0x0
11	R/W	DMA_IDLE	<p>0 = Blocking mode, the DMA performs a fast back-to-back copy, disabling bus access for any bus master with lower priority.</p> <p>1 = Interrupting mode, the DMA inserts a wait cycle after each store allowing the CPU to steal cycles or cache to perform a burst read. If DREQ_MODE='1', DMA_IDLE is don't care.</p>	0x0
10:8	R/W	DMA_PRIO	<p>The priority level determines which DMA channel will be granted access for transferring data, in case more than one channels are active and request the bus at the same time. The greater the value, the higher the priority. In specific:</p> <p>000 = lowest priority</p> <p>111 = highest priority</p> <p>If different channels with equal priority level values request the bus at the same time, an inherent priority mechanism is applied. According to this mechanism, if, for example, both the DMA0 and DMA1 channels have the same priority level, then DMA0 will first be granted access to the bus.</p>	0x0
7	R/W	CIRCULAR	<p>0 = Normal mode. The DMA channel stops after having completed the transfer of length determined by DMAx_LEN_REG. DMA_ON automatically deasserts when the transfer is completed.</p> <p>1 = Circular mode (applicable only if DREQ_MODE = '1'). In this mode, DMA_ON never deasserts, as the DMA channel automatically resets DMAx_IDX_REG and starts a new transfer.</p>	0x0
6	R/W	AINC	<p>Enable increment of source address.</p> <p>0 = do not increment (source address stays the same during the transfer)</p> <p>1 = increment according to the value of BW bit-field (by 1, when BW="00" ; by 2, when BW="01" ; by 4, when BW="10")</p>	0x0
5	R/W	BINC	<p>Enable increment of destination address.</p> <p>0 = do not increment (destination address stays the same during the transfer)</p> <p>1 = increment according to the value of BW bit-field (by 1, when BW="00" ; by 2, when BW="01" ; by 4, when BW="10")</p>	0x0
4	R/W	DREQ_MODE	<p>0 = DMA channel starts immediately</p> <p>1 = DMA channel must be triggered by peripheral DMA request (see also the description of DMA_REQ_MUX_REG)</p>	0x0
3	R/W	IRQ_ENABLE	<p>0 = disable interrupt on this channel</p>	0x0

Bit	Mode	Symbol	Description	Reset
			1 = enable interrupt on this channel	
2:1	R/W	BW	Bus transfer width: 00 = 1 Byte (suggested for peripherals like UART and 8-bit SPI) 01 = 2 Bytes (suggested for peripherals like I2C and 16-bit SPI) 10 = 4 Bytes (suggested for Memory-to-Memory transfers) 11 = Reserved	0x0
0	R/W	DMA_ON	0 = DMA channel is off, clocks are disabled 1 = DMA channel is enabled. This bit will be automatically cleared after the completion of a transfer, if circular mode is not enabled. In circular mode, this bit stays set.	0x0

Table 157: DMA1\_IDX\_REG (0x5000361E)

Bit	Mode	Symbol	Description	Reset
15:0	R	DMA1_IDX	This (read-only) register determines the data items currently fetched by the DMA channel, during an on-going transfer. When the transfer is completed, the register is automatically reset to 0. The DMA channel uses this register to form the source/destination address of the next DMA cycle, considering also AINC/BINC and BW.	0x0

Table 158: DMA2\_A\_STARTL\_REG (0x50003620)

Bit	Mode	Symbol	Description	Reset
15:0	R/W	DMA2_A_STARTL	Source start address, lower 16 bits	0x0

Table 159: DMA2\_A\_STARTH\_REG (0x50003622)

Bit	Mode	Symbol	Description	Reset
15:0	R/W	DMA2_A_STARTH	Source start address, upper 16 bits	0x0

Table 160: DMA2\_B\_STARTL\_REG (0x50003624)

Bit	Mode	Symbol	Description	Reset
15:0	R/W	DMA2_B_STARTL	Destination start address, lower 16 bits	0x0

Table 161: DMA2\_B\_STARTH\_REG (0x50003626)

Bit	Mode	Symbol	Description	Reset
15:0	R/W	DMA2_B_STARTH	Destination start address, upper 16 bits	0x0

Table 162: DMA2\_INT\_REG (0x50003628)

Bit	Mode	Symbol	Description	Reset
15:0	R/W	DMA2_INT	Number of transfers until an interrupt is generated. The interrupt is generated after a transfer, if DMAx_INT_REG is equal to DMAx_IDX_REG and before DMAx_IDX_REG is incremented. The bit-field IRQ_ENABLE of DMAx_CTRL_REG must be set to '1' to let the controller generate the interrupt.	0x0

Table 163: DMA2\_LEN\_REG (0x5000362A)

Bit	Mode	Symbol	Description	Reset
15:0	R/W	DMA2_LEN	DMA channel's transfer length. DMAx_LEN of value 0, 1, 2, ... results into an actual transfer length of 1, 2, 3, ...	0x0

Table 164: DMA2\_CTRL\_REG (0x5000362C)

Bit	Mode	Symbol	Description	Reset
15:14	R	-		0x0
13	R/W	REQ_SENSE	0 = DMA operates with level-sensitive peripheral requests (default) 1 = DMA operates with (positive) edge-sensitive peripheral requests	0x0
12	R/W	DMA_INIT	0 = DMA performs copy A1 to B1, A2 to B2, etc ... 1 = DMA performs copy of A1 to B1, B2, etc ... This feature is useful for memory initialization to any value. Thus, BINC must be set to '1', while AINC is don't care, as only one fetch from A is done. This process cannot be interrupted by other DMA channels. It is also noted that DMA_INIT should not be used when DREQ_MODE='1'.	0x0
11	R/W	DMA_IDLE	0 = Blocking mode, the DMA performs a fast back-to-back copy, disabling bus access for any bus master with lower priority. 1 = Interrupting mode, the DMA inserts a wait cycle after each store allowing the CPU to steal cycles or cache to perform a burst read. If DREQ_MODE='1', DMA_IDLE is don't care.	0x0
10:8	R/W	DMA_PRIO	The priority level determines which DMA channel will be granted access for transferring data, in case more than one channels are active and request the bus at the same time. The greater the value, the higher the priority. In specific: 000 = lowest priority 111 = highest priority If different channels with equal priority level values request the bus at the same time, an inherent priority mechanism is applied. According to this mechanism, if, for example, both the DMA0 and	0x0



Bit	Mode	Symbol	Description	Reset
			DMA1 channels have the same priority level, then DMA0 will first be granted access to the bus.	
7	R/W	CIRCULAR	0 = Normal mode. The DMA channel stops after having completed the transfer of length determined by DMAx_LEN_REG. DMA_ON automatically deasserts when the transfer is completed. 1 = Circular mode (applicable only if DREQ_MODE = '1'). In this mode, DMA_ON never deasserts, as the DMA channel automatically resets DMAx_IDX_REG and starts a new transfer.	0x0
6	R/W	AINC	Enable increment of destination address. 0 = do not increment (destination address stays the same during the transfer) 1 = increment according to the value of BW bit-field (by 1, when BW="00" ; by 2, when BW="01" ; by 4, when BW="10")	0x0
5	R/W	BINC	Enable increment of destination address 0 = do not increment 1 = increment according value of BW	0x0
4	R/W	DREQ_MODE	0 = DMA channel starts immediately 1 = DMA channel must be triggered by peripheral DMA request (see also the description of DMA_REQ_MUX_REG)	0x0
3	R/W	IRQ_ENABLE	0 = disable interrupt on this channel 1 = enable interrupt on this channel	0x0
2:1	R/W	BW	Bus transfer width: 00 = 1 Byte (suggested for peripherals like UART and 8-bit SPI) 01 = 2 Bytes (suggested for peripherals like I2C and 16-bit SPI) 10 = 4 Bytes (suggested for Memory-to-Memory transfers) 11 = Reserved	0x0
0	R/W	DMA_ON	0 = DMA channel is off, clocks are disabled 1 = DMA channel is enabled. This bit will be automatically cleared after the completion of a transfer, if circular mode is not enabled. In circular mode, this bit stays set.	0x0

Table 165: DMA2\_IDX\_REG (0x5000362E)

Bit	Mode	Symbol	Description	Reset
15:0	R	DMA2_IDX	This (read-only) register determines the data items currently fetched by the DMA channel, during an on-going transfer. When the transfer is completed, the register is automatically reset to 0. The DMA channel uses this register to form the source/destination address of the next DMA cycle, considering also AINC/BINC and BW.	0x0

Table 166: DMA3\_A\_STARTL\_REG (0x50003630)

Bit	Mode	Symbol	Description	Reset
15:0	R/W	DMA3_A_STARTL	Source start address, lower 16 bits	0x0

Table 167: DMA3\_A\_STARTH\_REG (0x50003632)

Bit	Mode	Symbol	Description	Reset
15:0	R/W	DMA3_A_STARTH	Source start address, upper 16 bits	0x0

Table 168: DMA3\_B\_STARTL\_REG (0x50003634)

Bit	Mode	Symbol	Description	Reset
15:0	R/W	DMA3_B_STARTL	Destination start address, lower 16 bits	0x0

Table 169: DMA3\_B\_STARTH\_REG (0x50003636)

Bit	Mode	Symbol	Description	Reset
15:0	R/W	DMA3_B_STARTH	Destination start address, upper 16 bits	0x0

Table 170: DMA3\_INT\_REG (0x50003638)

Bit	Mode	Symbol	Description	Reset
15:0	R/W	DMA3_INT	Number of transfers until an interrupt is generated. The interrupt is generated after a transfer, if DMAx_INT_REG is equal to DMAx_IDX_REG and before DMAx_IDX_REG is incremented. The bit-field IRQ_ENABLE of DMAx_CTRL_REG must be set to '1' to let the controller generate the interrupt.	0x0

Table 171: DMA3\_LEN\_REG (0x5000363A)

Bit	Mode	Symbol	Description	Reset
15:0	R/W	DMA3_LEN	DMA channel's transfer length. DMAx_LEN of value 0, 1, 2, ... results into an actual transfer length of 1, 2, 3, ...	0x0

Table 172: DMA3\_CTRL\_REG (0x5000363C)

Bit	Mode	Symbol	Description	Reset
15:14	R	-		0x0
13	R/W	REQ_SENSE	0 = DMA operates with level-sensitive peripheral requests (default)	0x0

Bit	Mode	Symbol	Description	Reset
			1 = DMA operates with (positive) edge-sensitive peripheral requests	
12	R/W	DMA_INIT	0 = DMA performs copy A1 to B1, A2 to B2, etc ... 1 = DMA performs copy of A1 to B1, B2, etc ... This feature is useful for memory initialization to any value. Thus, BINC must be set to '1', while AINC is don't care, as only one fetch from A is done. This process cannot be interrupted by other DMA channels. It is also noted that DMA_INIT should not be used when DREQ_MODE='1'.	0x0
11	R/W	DMA_IDLE	0 = Blocking mode, the DMA performs a fast back-to-back copy, disabling bus access for any bus master with lower priority. 1 = Interrupting mode, the DMA inserts a wait cycle after each store allowing the CPU to steal cycles or cache to perform a burst read. If DREQ_MODE='1', DMA_IDLE is don't care.	0x0
10:8	R/W	DMA_PRIO	The priority level determines which DMA channel will be granted access for transferring data, in case more than one channels are active and request the bus at the same time. The greater the value, the higher the priority. In specific: 000 = lowest priority 111 = highest priority If different channels with equal priority level values request the bus at the same time, an inherent priority mechanism is applied. According to this mechanism, if, for example, both the DMA0 and DMA1 channels have the same priority level, then DMA0 will first be granted access to the bus.	0x0
7	R/W	CIRCULAR	0 = Normal mode. The DMA channel stops after having completed the transfer of length determined by DMAx_LEN_REG. DMA_ON automatically deasserts when the transfer is completed. 1 = Circular mode (applicable only if DREQ_MODE = '1'). In this mode, DMA_ON never deasserts, as the DMA channel automatically resets DMAx_IDX_REG and starts a new transfer.	0x0
6	R/W	AINC	Enable increment of source address. 0 = do not increment (source address stays the same during the transfer) 1 = increment according to the value of BW bit-field (by 1, when BW="00" ; by 2, when BW="01" ; by 4, when BW="10")	0x0
5	R/W	BINC	Enable increment of destination address. 0 = do not increment (destination address stays the same during the transfer) 1 = increment according to the value of BW bit-field (by 1, when BW="00" ; by 2, when BW="01" ; by 4, when BW="10")	0x0
4	R/W	DREQ_MODE	0 = DMA channel starts immediately 1 = DMA channel must be triggered by peripheral DMA request (see also the description of DMA_REQ_MUX_REG)	0x0

Bit	Mode	Symbol	Description	Reset
3	R/W	IRQ_ENABLE	0 = disable interrupt on this channel 1 = enable interrupt on this channel	0x0
2:1	R/W	BW	Bus transfer width: 00 = 1 Byte (suggested for peripherals like UART and 8-bit SPI) 01 = 2 Bytes (suggested for peripherals like I2C and 16-bit SPI) 10 = 4 Bytes (suggested for Memory-to-Memory transfers) 11 = Reserved	0x0
0	R/W	DMA_ON	0 = DMA channel is off, clocks are disabled 1 = DMA channel is enabled. This bit will be automatically cleared after the completion of a transfer, if circular mode is not enabled. In circular mode, this bit stays set.	0x0

Table 173: DMA3\_IDX\_REG (0x5000363E)

Bit	Mode	Symbol	Description	Reset
15:0	R	DMA3_IDX	This (read-only) register determines the data items currently fetched by the DMA channel, during an on-going transfer. When the transfer is completed, the register is automatically reset to 0.  The DMA channel uses this register to form the source/destination address of the next DMA cycle, considering also AINC/BINC and BW.	0x0

Table 174: DMA\_REQ\_MUX\_REG (0x50003680)

Bit	Mode	Symbol	Description	Reset
15:12	R/W	-		0xF
11:8	R/W	-		0xF
7:4	R/W	DMA23_SEL	Select which combination of peripherals are mapped on the DMA channels. The peripherals are mapped as pairs on two channels.  Hence, the first DMA request (peripheral-to-memory) is mapped on channel 2 and the second (memory-to-peripheral) on channel 3.  See also the description of DMA01_SEL bit-field of this register for the supported peripherals.	0xF
3:0	R/W	DMA01_SEL	Select which combination of peripherals are mapped on the DMA channels. The peripherals are mapped as pairs on two channels.  Hence, the first DMA request (peripheral-to-memory) is mapped on channel 0 and the second (memory-to-peripheral) on channel 1.  0x0: SPI_rx / SPI_tx 0x1: Reserved 0x2: UART_rx / UART_tx 0x3: UART2_rx / UART2_tx	0xF

Bit	Mode	Symbol	Description	Reset
			0x4: I2C_rx / I2C_tx 0x5: GP_ADC (Rx only) 0x6-0xE: Reserved 0xF: None  Note: If any of the two available peripheral selector fields (DMA01_SEL, DMA23_SEL) have the same value, the lesser significant selector has higher priority and will control the dma acknowledge. Hence, if DMA01_SEL = DMA23_SEL, the channels 0 and 1 will generate the DMA acknowledge signals for the selected peripheral. Consequently, it is suggested to assign the intended peripheral value to a unique selector field.	

Table 175: DMA\_INT\_STATUS\_REG (0x50003682)

Bit	Mode	Symbol	Description	Reset
15:8	R	-		0x0
7	R	-		0x0
6	R	-		0x0
5	R	-		0x0
4	R	-		0x0
3	R	DMA_IRQ_CH3	0: IRQ on channel 3 is not set 1: IRQ on channel 3 is set	0x0
2	R	DMA_IRQ_CH2	0: IRQ on channel 2 is not set 1: IRQ on channel 2 is set	0x0
1	R	DMA_IRQ_CH1	0: IRQ on channel 1 is not set 1: IRQ on channel 1 is set	0x0
0	R	DMA_IRQ_CH0	0: IRQ on channel 0 is not set 1: IRQ on channel 0 is set	0x0

Table 176: DMA\_CLEAR\_INT\_REG (0x50003684)

Bit	Mode	Symbol	Description	Reset
15:8	R	-		0x0
7	R	-		0x0
6	R	-		0x0
5	R	-		0x0
4	R	-		0x0
3	R0/W	DMA_RST_IRQ_CH3	Writing a 1 will reset the status bit of DMA_INT_STATUS_REG for channel 3 ; writing a 0 will have no effect	0x0

Bit	Mode	Symbol	Description	Reset
2	R0/W	DMA_RST_IRQ_CH 2	Writing a 1 will reset the status bit of DMA_INT_STATUS_REG for channel 2 ; writing a 0 will have no effect	0x0
1	R0/W	DMA_RST_IRQ_CH 1	Writing a 1 will reset the status bit of DMA_INT_STATUS_REG for channel 1 ; writing a 0 will have no effect	0x0
0	R0/W	DMA_RST_IRQ_CH 0	Writing a 1 will reset the status bit of DMA_INT_STATUS_REG for channel 0 ; writing a 0 will have no effect	0x0

### 31.5 General Purpose ADC Registers

**Table 177: Register map GPADC**

Address	Register	Description
0x50001500	GP_ADC_CTRL_REG	General Purpose ADC Control Register
0x50001502	GP_ADC_CTRL2_REG	General Purpose ADC Second Control Register
0x50001504	GP_ADC_CTRL3_REG	General Purpose ADC Third Control Register
0x50001506	GP_ADC_SEL_REG	General Purpose ADC Input Selection Register
0x50001508	GP_ADC_OFFP_REG	General Purpose ADC Positive Offset Register
0x5000150A	GP_ADC_OFFN_REG	General Purpose ADC Negative Offset Register
0x5000150C	GP_ADC_TRIM_REG	General Purpose ADC Trim Register
0x5000150E	GP_ADC_CLEAR_INT_REG	General Purpose ADC Clear Interrupt Register
0x50001510	GP_ADC_RESULT_REG	General Purpose ADC Result Register

**Table 178: GP\_ADC\_CTRL\_REG (0x50001500)**

Bit	Mode	Symbol	Description	Reset
12	R/W	DIE_TEMP_EN	Enables the die-temperature sensor. Output can be measured on GPADC input 4.	0x0
11	-	-		0x0
10	R/W	GP_ADC_LDO_HOLD	0: GPADC LDO tracking bandgap reference 1: GPADC LDO hold sampled bandgap reference	0x0
9	R/W	GP_ADC_CHOP	0: Chopper mode off 1: Chopper mode enabled. Takes two samples with opposite GP_ADC_SIGN to cancel the internal offset voltage of the ADC; Highly recommended for DC-measurements.	0x0
8	R/W	GP_ADC_SIGN	0: Default 1: Conversion with opposite sign at input and output to cancel out the internal offset of the ADC and low-frequency	0x0
7	R/W	GP_ADC_MUTE	0: Normal operation 1: Mute ADC input. Takes sample at mid-scale (to determine the internal offset and/or noise of the ADC with regards to VDD_REF which is also sampled by the ADC).	0x0
6	R/W	GP_ADC_SE	0: Differential mode 1: Single ended mode	0x0
5	R/W	GP_ADC_MINT	0: Disable (mask) GP_ADC_INT. 1: Enable GP_ADC_INT to ICU.	0x0

Bit	Mode	Symbol	Description	Reset
4	R	GP_ADC_INT	1: AD conversion ready and has generated an interrupt. Must be cleared by writing any value to GP_ADC_CLEAR_INT_REG.	0x0
3	R/W	GP_ADC_DMA_EN	0: DMA functionality disabled 1: DMA functionality enabled	0x0
2	R/W	GP_ADC_CONT	0: Manual ADC mode, a single result will be generated after setting the GP_ADC_START bit. 1: Continuous ADC mode, new ADC results will be constantly stored in GP_ADC_RESULT_REG. Still GP_ADC_START has to be set to start the execution. The time between conversions is configurable with GP_ADC_INTERVAL.	0x0
1	R/W	GP_ADC_START	0: ADC conversion ready. 1: If a 1 is written, the ADC starts a conversion. After the conversion this bit will be set to 0 and the GP_ADC_INT bit will be set. It is not allowed to write this bit while it is not (yet) zero.	0x0
0	R/W	GP_ADC_EN	0: LDO is off and ADC is disabled.. 1: LDO is turned on and afterwards the ADC is enabled.	0x0

Table 179: GP\_ADC\_CTRL2\_REG (0x50001502)

Bit	Mode	Symbol	Description	Reset
15:13	R/W	GP_ADC_STORE_DEL	0: Data is stored after handshake synchronisation 1: Data is stored 2 ADC_CLK cycles after internal start trigger 7: Data is stored 8 ADC_CLK cycles after internal start trigger	0x0
12:9	R/W	GP_ADC_SMPL_TIME	0: The sample time (switch is closed) is two ADC_CLK cycles 1: The sample time is 1*8 ADC_CLK cycles 2: The sample time is 2*8 ADC_CLK cycles 15: The sample time is 15*8 ADC_CLK cycles	0x1
8:6	R/W	GP_ADC_CONV_NRS	0: 1 sample is taken or 2 in case ADC_CHOP is active. 1: 2 samples are taken. 2: 4 samples are taken. 7: 128 samples are taken.	0x0
5:4	R/W	GP_ADC_OFFS_SH_CM	Common mode adjust for offset shifter. Input range is CM +/- 450mV. 0: CM = 1.25V (Input range 0.80 - 1.70) 1: CM = 1.30V (Input range 0.85 - 1.75) (default) 2: CM = 1.35V (Input range 0.90 - 1.80) 3: CM = 1.40V (input range 0.95 - 1.85)	0x1
3	R/W	GP_ADC_OFFS_SH_EN	0: Disable input shifter 1: Enable input shifter (900mV - 1800mV shifted to 0mV - 900mV)	0x0



Bit	Mode	Symbol	Description	Reset
2	R/W	GP_ADC_I20U	1: Adds 20uA constant load current at the ADC LDO to minimize ripple on the reference voltage of the ADC.	0x0
1:0	R/W	GP_ADC_ATTN	0: No attenuator (input voltages up to 0.9V allowed) 1: Enabling 2x attenuator (input voltages up to 1.8V allowed) 2: Enabling 3x attenuator (input voltages up to 2.7V allowed) 3: Enabling 4x attenuator (input voltages up to 3.6V allowed) Enabling the attenuator requires a longer sampling time.	0x0

Table 180: GP\_ADC\_CTRL3\_REG (0x50001504)

Bit	Mode	Symbol	Description	Reset
15:8	R/W	GP_ADC_INTERVAL	Defines the interval between two ADC conversions in case GP_ADC_CONT is set. 0: No extra delay between two conversions. 1: 1.024 ms interval between two conversions. 2: 2.048 ms interval between two conversions. 255: 261.12 ms interval between two conversions.	0x0
7:0	R/W	GP_ADC_EN_DEL	Defines the delay for enabling the ADC after enabling the LDO. 0: Not allowed 1: 4x ADC_CLK period. n: n*4x ADC_CLK period.	0x40

Table 181: GP\_ADC\_OFFP\_REG (0x50001508)

Bit	Mode	Symbol	Description	Reset
9:0	R/W	GP_ADC_OFFP	Offset adjust of 'positive' array of ADC-network (effective if "GP_ADC_SE=0", or "GP_ADC_SE=1 AND GP_ADC_SIGN=0 OR GP_ADC_CHOP=1")	0x200

Table 182: GP\_ADC\_OFFN\_REG (0x5000150A)

Bit	Mode	Symbol	Description	Reset
9:0	R/W	GP_ADC_OFFN	Offset adjust of 'negative' array of ADC-network (effective if "GP_ADC_SE=0", or "GP_ADC_SE=1 AND GP_ADC_SIGN=1 OR GP_ADC_CHOP=1")	0x200

Table 183: GP\_ADC\_TRIM\_REG (0x5000150C)

Bit	Mode	Symbol	Description	Reset
6:4	R/W	GP_ADC_LDO_LEV EL	GPADC LDO level 0: 825mV 1: 850mV 2: 875mV 3: 900mV (reset) 4: 925mV (default) 5: 950mV 6: 975mV 7:1000mV	0x3
3:0	R/W	GP_ADC_OFFS_S H_VREF	Offset Shifter common-mode reference fine trimming: 2mV/LSB Default = mid-scale at 1000	0x8

Table 184: GP\_ADC\_CLEAR\_INT\_REG (0x5000150E)

Bit	Mode	Symbol	Description	Reset
15:0	R0/W	GP_ADC_CLR_INT	Writing any value to this register will clear the ADC_INT interrupt. Reading returns 0.	0x0

Table 185: GP\_ADC\_RESULT\_REG (0x50001510)

Bit	Mode	Symbol	Description	Reset
15:0	R	GP_ADC_VAL	Returns the 10 up to 16 bits linear value of the last AD conversion. The upper 10 bits are always valid, the lower 6 bits are only valid in case oversampling has been applied. Two samples results in one extra bit and 64 samples results in six extra bits.	0x0

Table 186: GP\_ADC\_SEL\_REG (0x50001506)

Bit	Mode	Symbol	Description	Reset
7	-	-		0x0
6:4	R/W	GP_ADC_SEL_P	ADC positive input selection. 0: ADC0 (P0[1]) 1: ADC1 (P0[2]) 2: ADC2 (P0[6]) 3: ADC3 (P0[7]) 4: Temperature Sensor 5: VBAT_HIGH 6: VBAT_LOW 7: VDDD	0x0
3	-	-		0x0

Bit	Mode	Symbol	Description	Reset
2:0	R/W	GP_ADC_SEL_N	ADC negative input selection. Differential only (GP_ADC_SE=0). 0: ADC0 (P0[1]) 1: ADC1 (P0[2]) 2: ADC2 (P0[6]) 3: ADC3 (P0[7]) All other combinations are reserved.	0x0

## 31.6 General Purpose I/O Registers

**Table 187: Register map GPIO**

Address	Register	Description
0x50003000	P0_DATA_REG	P0 Data input/output Register
0x50003002	P0_SET_DATA_REG	P0 Set port pins Register
0x50003004	P0_RESET_DATA_REG	P0 Reset port pins Register
0x50003006	P00_MODE_REG	P00 Mode Register
0x50003008	P01_MODE_REG	P01 Mode Register
0x5000300A	P02_MODE_REG	P02 Mode Register
0x5000300C	P03_MODE_REG	P03 Mode Register
0x5000300E	P04_MODE_REG	P04 Mode Register
0x50003010	P05_MODE_REG	P05 Mode Register
0x50003012	P06_MODE_REG	P06 Mode Register
0x50003014	P07_MODE_REG	P07 Mode Register
0x50003016	P08_MODE_REG	P08 Mode Register
0x50003018	P09_MODE_REG	P09 Mode Register
0x5000301A	P010_MODE_REG	P010 Mode Register
0x5000301C	P011_MODE_REG	P011 Mode Register
0x5000301E	PAD_WEAK_CTRL_REG	Pad driving strength control Register

**Table 188: P0\_DATA\_REG (0x50003000)**

Bit	Mode	Symbol	Description	Reset
15:12	-	-		0x0
11:0	R/W	P0_DATA	Sets P0 output register when written ; Returns the value of P0 port when read	0x0

**Table 189: P0\_SET\_DATA\_REG (0x50003002)**

Bit	Mode	Symbol	Description	Reset
15:12	-	-		0x0
11:0	R0/W	P0_SET	Writing a 1 to P0[x] sets P0[x] to 1. Writing 0 is discarded, reading returns 0	0x0

**Table 190: P0\_RESET\_DATA\_REG (0x50003004)**

Bit	Mode	Symbol	Description	Reset
15:12	-	-		0x0

Bit	Mode	Symbol	Description	Reset
11:0	R0/W	P0_RESET	Writing a 1 to P0[x] sets P0[x] to 0. Writing 0 is discarded, reading returns 0.	0x0

Table 191: P00\_MODE\_REG (0x50003006)

Bit	Mode	Symbol	Description	Reset
15:10	-	-		0x0
9:8	R/W	PUPD	00 = Input, no resistors selected 01 = Input, pull-up selected 10 = Input, pull-down selected 11 = Output, no resistors selected In ADC mode, these bits are don't care	0x2
7:5	-	-		0x0
4:0	R/W	PID	Function of port 0 = GPIO (pin direction determined by "PUPD" field) 1 = UART1_RX 2 = UART1_TX 3 = UART2_RX 4 = UART2_TX 5 = SYS_CLK 6 = LP_CLK 7 = Reserved 8 = Reserved 9 = I2C_SCL 10 = I2C_SDA 11 = PWM5 12 = PWM6 13 = PWM7 14 = Reserved 15 = ADC (only for P0_1, P0_2, P0_6 and P0_7) 16 = PWM0 17 = PWM1 18 = BLE_DIAG (signals mapped to P0[3:0] are also mapped to P0[11:8]) 19 = UART1_CTSN 20 = UART1_RTSEN 21 = Reserved 22 = Reserved 23 = PWM2 24 = PWM3 25 = PWM4 26 = SPI_DI 27 = SPI_DO 28 = SPI_CLK 29 = SPI_CSN0 30 = SPI_CSN1	0x0

Bit	Mode	Symbol	Description	Reset
			31 = Reserved Note: When a certain input function (like SPI_DI) is selected on more than 1 pins, the pin of the lowest index has the highest priority.	

Table 192: P01\_MODE\_REG (0x50003008)

Bit	Mode	Symbol	Description	Reset
15:10	-	-		0x0
9:8	R/W	PUPD	00 = Input, no resistors selected 01 = Input, pull-up selected 10 = Input, pull-down selected 11 = Output, no resistors selected In ADC mode, these bits are don't care	0x2
7:5	-	-		0x0
4:0	R/W	PID	See P00_MODE_REG[PID]	0x0

Table 193: P02\_MODE\_REG (0x5000300A)

Bit	Mode	Symbol	Description	Reset
15:10	-	-		0x0
9:8	R/W	PUPD	00 = Input, no resistors selected 01 = Input, pull-up selected 10 = Input, pull-down selected 11 = Output, no resistors selected In ADC mode, these bits are don't care	0x2
7:5	-	-		0x0
4:0	R/W	PID	See P00_MODE_REG[PID]	0x0

Table 194: P03\_MODE\_REG (0x5000300C)

Bit	Mode	Symbol	Description	Reset
15:10	-	-		0x0
9:8	R/W	PUPD	00 = Input, no resistors selected 01 = Input, pull-up selected 10 = Input, pull-down selected 11 = Output, no resistors selected In ADC mode, these bits are don't care	0x2
7:5	-	-		0x0
4:0	R/W	PID	See P00_MODE_REG[PID]	0x0

Table 195: P04\_MODE\_REG (0x5000300E)

Bit	Mode	Symbol	Description	Reset
15:10	-	-		0x0
9:8	R/W	PUPD	00 = Input, no resistors selected 01 = Input, pull-up selected 10 = Input, pull-down selected 11 = Output, no resistors selected	0x2
7:5	-	-		0x0
4:0	R/W	PID	See P00_MODE_REG[PID]	0x0

Table 196: P05\_MODE\_REG (0x50003010)

Bit	Mode	Symbol	Description	Reset
15:10	-	-		0x0
9:8	R/W	PUPD	00 = Input, no resistors selected 01 = Input, pull-up selected 10 = Input, pull-down selected 11 = Output, no resistors selected	0x2
7:5	-	-		0x0
4:0	R/W	PID	See P00_MODE_REG[PID]	0x0

Table 197: P06\_MODE\_REG (0x50003012)

Bit	Mode	Symbol	Description	Reset
15:10	-	-		0x0
9:8	R/W	PUPD	00 = Input, no resistors selected 01 = Input, pull-up selected 10 = Input, pull-down selected 11 = Output, no resistors selected	0x2
7:5	-	-		0x0
4:0	R/W	PID	See P00_MODE_REG[PID]	0x0

Table 198: P07\_MODE\_REG (0x50003014)

Bit	Mode	Symbol	Description	Reset
15:10	-	-		0x0
9:8	R/W	PUPD	00 = Input, no resistors selected 01 = Input, pull-up selected 10 = Input, pull-down selected 11 = Output, no resistors selected	0x2
7:5	-	-		0x0
4:0	R/W	PID	See P00_MODE_REG[PID]	0x0

Table 199: P08\_MODE\_REG (0x50003016)

Bit	Mode	Symbol	Description	Reset
15:10	-	-		0x0
9:8	R/W	PUPD	00 = Input, no resistors selected 01 = Input, pull-up selected 10 = Input, pull-down selected 11 = Output, no resistors selected	0x2
7:5	-	-		0x0
4:0	R/W	PID	See P00_MODE_REG[PID]	0x0

Table 200: P09\_MODE\_REG (0x50003018)

Bit	Mode	Symbol	Description	Reset
15:10	-	-		0x0
9:8	R/W	PUPD	00 = Input, no resistors selected 01 = Input, pull-up selected 10 = Input, pull-down selected 11 = Output, no resistors selected	0x2
7:5	-	-		0x0
4:0	R/W	PID	See P00_MODE_REG[PID]	0x0

Table 201: P010\_MODE\_REG (0x5000301A)

Bit	Mode	Symbol	Description	Reset
15:10	-	-		0x0
9:8	R/W	PUPD	00 = Input, no resistors selected 01 = Input, pull-up selected 10 = Input, pull-down selected 11 = Output, no resistors selected	0x2
7:5	-	-		0x0
4:0	R/W	PID	See P00_MODE_REG[PID]	0x0

Table 202: P011\_MODE\_REG (0x5000301C)

Bit	Mode	Symbol	Description	Reset
15:10	-	-		0x0
9:8	R/W	PUPD	00 = Input, no resistors selected 01 = Input, pull-up selected 10 = Input, pull-down selected 11 = Output, no resistors selected	0x2
7:5	-	-		0x0



Bit	Mode	Symbol	Description	Reset
4:0	R/W	PID	See P00_MODE_REG[PID]	0x0

Table 203: PAD\_WEAK\_CTRL\_REG (0x5000301E)

Bit	Mode	Symbol	Description	Reset
15:12	-	-		0x0
11:0	R/W	PAD_LOW_DRV	0 = Normal operation 1 = Reduces the driving strength of P0_x pad. Bit x controls the driving strength of P0_x, x=0, 1,..., 11.	0x0

### 31.7 General Purpose Registers

**Table 204: Register map GPREG**

Address	Register	Description
0x50003300	SET_FREEZE_REG	Controls freezing of various timers/counters.
0x50003302	RESET_FREEZE_REG	Controls unfreezing of various timers/counters.
0x50003304	DEBUG_REG	Various debug information register.
0x50003306	GP_STATUS_REG	General purpose system status register.
0x50003308	GP_CONTROL_REG	General purpose system control register.
0x5000330A	BLE_TIMER_REG	BLE FINECNT sampled value while in deep sleep state.

**Table 205: SET\_FREEZE\_REG (0x50003300)**

Bit	Mode	Symbol	Description	Reset
15:5	-	-		0x0
4	R/W	FRZ_DMA	If '1', the DMA is frozen, '0' is discarded.	0x0
3	R/W	FRZ_WDOG	If '1', the watchdog timer is frozen, '0' is discarded. WATCHDOG_CTRL_REG[NMI_RST] must be '0' to allow the freeze function.	0x0
2	R/W	FRZ_BLETIM	If '1', the BLE master clock is frozen, '0' is discarded.	0x0
1	R/W	FRZ_SWTIM	If '1', the SW Timer (TIMER0) is frozen, '0' is discarded.	0x0
0	R/W	FRZ_WKUPTIM	If '1', the Wake Up Timer is frozen, '0' is discarded.	0x0

**Table 206: RESET\_FREEZE\_REG (0x50003302)**

Bit	Mode	Symbol	Description	Reset
15:5	-	-		0x0
4	R/W	FRZ_DMA	If '1', the DMA continues, '0' is discarded.	0x0
3	R/W	FRZ_WDOG	If '1', the watchdog timer continues, '0' is discarded.	0x0
2	R/W	FRZ_BLETIM	If '1', the the BLE master clock continues, '0' is discarded.	0x0
1	R/W	FRZ_SWTIM	If '1', the SW Timer (TIMER0) continues, '0' is discarded.	0x0
0	R/W	FRZ_WKUPTIM	If '1', the Wake Up Timer continues, '0' is discarded.	0x0

Table 207: **DEBUG\_REG (0x50003304)**

Bit	Mode	Symbol	Description	Reset
15:1	R/W	-		0x0
0	R/W	DEBUGS_FREEZE_EN	Default '1', freezing of the on-chip timers is enabled when the Cortex is halted in DEBUG State.  If '0', freezing of the on-chip timers is depending on FREEZE_REG when the Cortex is halted in DEBUG State <u>except</u> the watchdog timer. The watchdog timer is always frozen when the Cortex is halted in DEBUG State.	0x1

Table 208: **GP\_STATUS\_REG (0x50003306)**

Bit	Mode	Symbol	Description	Reset
15:2	-	-		0x0
1	R/W	-		0x0
0	R/W	CAL_PHASE	If '1', it designates that the chip is in Calibration Phase i.e. the OTP has been initially programmed but no Calibration has occurred.	0x0

Table 209: **GP\_CONTROL\_REG (0x50003308)**

Bit	Mode	Symbol	Description	Reset
15:7	-	-		0x0
6:5	R/W	BLE_TIMER_DATA_CTRL	Refer to BLE_TIMER_REG.	0x0
4	R/W	CPU_DMA_BUS_PRIORITY	Controls the CPU DMA system bus priority: If '0', the CPU has highest priority. If '1', the DMA has highest priority.	0x0
3	-	-		0x0
2	R	BLE_WAKEUP_LP_IRQ	The current value of the BLE_WAKEUP_LP_IRQ interrupt request.	0x0
1	-	-		0x0
0	R/W	BLE_WAKEUP_REQ	If '1', the BLE wakes up. Must be kept high at least for 1 low power clock period.  If the BLE is in deep sleep state, then by setting this bit it will cause the wakeup LP IRQ to be asserted with a delay of 3 to 4 low power cycles.	0x0

Table 210: **BLE\_TIMER\_REG (0x5000330A)**

Bit	Mode	Symbol	Description	Reset
15:10	-	-		0x0
9:0	R/W	BLE_TIMER_DATA	Operation depends on GP_CONTROL_REG->BLE_TIMER_DATA_CTRL.	0x0

Bit	Mode	Symbol	Description	Reset
			<p>If BLE_TIMER_DATA_CTRL = 0 then:</p> <p>This register is located at the Always On Power Domain and it holds the automatically sampled value of the BLE FINECNT timer</p> <p>The HW automatically samples the value into this register during the sequence of "BLE Sleep On" and restores automatically the value during the BLE Wake up sequence.</p> <p>The Software may read and modify the value while the BLE is in Sleep state. While the BLE is awake, the value of the register has no meaning, while changing the value by writing another one will have no effect in the operation of the BLE core.</p> <p>There is a constraint when the SW performs a write-read sequence where it has to inject a one cycle delay in between (e.g. write-NOP-read) in order to read back the correct value.</p> <p>If BLE_TIMER_DATA_CTRL is non 0 then write operations have the same effect as when BLE_TIMER_DATA_CTRL=0, while for read operations:</p> <p>BLE_TIMER_DATA_CTRL= 1: then reading BLE_TIMER_REG returns "deepsldur[9:0]".</p> <p>BLE_TIMER_DATA_CTRL= 2: then reading BLE_TIMER_REG returns "deepsstime_samp[9:0]".</p> <p>BLE_TIMER_DATA_CTRL= 3: then reading BLE_TIMER_REG returns "{deep_sleep_stat_monitor, deepstime_samp[18:10]}".</p> <p>.</p>	

## 31.8 I2C Interface Registers

Table 211: Register map I2C

Address	Register	Description
0x50001300	I2C_CON_REG	I2C Control Register
0x50001304	I2C_TAR_REG	I2C Target Address Register
0x50001308	I2C_SAR_REG	I2C Slave Address Register
0x50001310	I2C_DATA_CMD_REG	I2C Rx/Tx Data Buffer and Command Register
0x50001314	I2C_SS_SCL_HCNT_REG	Standard Speed I2C Clock SCL High Count Register
0x50001318	I2C_SS_SCL_LCNT_REG	Standard Speed I2C Clock SCL Low Count Register
0x5000131C	I2C_FS_SCL_HCNT_REG	Fast Speed I2C Clock SCL High Count Register
0x50001320	I2C_FS_SCL_LCNT_REG	Fast Speed I2C Clock SCL Low Count Register
0x5000132C	I2C_INTR_STAT_REG	I2C Interrupt Status Register
0x50001330	I2C_INTR_MASK_REG	I2C Interrupt Mask Register
0x50001334	I2C_RAW_INTR_STAT_REG	I2C Raw Interrupt Status Register
0x50001338	I2C_RX_TL_REG	I2C Receive FIFO Threshold Register
0x5000133C	I2C_TX_TL_REG	I2C Transmit FIFO Threshold Register
0x50001340	I2C_CLR_INTR_REG	Clear Combined and Individual Interrupt Register
0x50001344	I2C_CLR_RX_UNDER_REG	Clear RX_UNDER Interrupt Register
0x50001348	I2C_CLR_RX_OVER_REG	Clear RX_OVER Interrupt Register
0x5000134C	I2C_CLR_TX_OVER_REG	Clear TX_OVER Interrupt Register
0x50001350	I2C_CLR_RD_REQ_REG	Clear RD_REQ Interrupt Register
0x50001354	I2C_CLR_TX_ABRT_REG	Clear TX_ABRT Interrupt Register
0x50001358	I2C_CLR_RX_DONE_REG	Clear RX_DONE Interrupt Register
0x5000135C	I2C_CLR_ACTIVITY_REG	Clear ACTIVITY Interrupt Register
0x50001360	I2C_CLR_STOP_DET_REG	Clear STOP_DET Interrupt Register
0x50001364	I2C_CLR_START_DET_REG	Clear START_DET Interrupt Register
0x50001368	I2C_CLR_GEN_CALL_REG	Clear GEN_CALL Interrupt Register
0x5000136C	I2C_ENABLE_REG	I2C Enable Register

Address	Register	Description
0x50001370	<a href="#">I2C_STATUS_REG</a>	I2C Status Register
0x50001374	<a href="#">I2C_TXFLR_REG</a>	I2C Transmit FIFO Level Register
0x50001378	<a href="#">I2C_RXFLR_REG</a>	I2C Receive FIFO Level Register
0x5000137C	<a href="#">I2C_SDA_HOLD_REG</a>	I2C SDA Hold Time Length Register
0x50001380	<a href="#">I2C_TX_ABRT_SOUR CE_REG</a>	I2C Transmit Abort Source Register
0x50001388	<a href="#">I2C_DMA_CR_REG</a>	DMA Control Register
0x5000138C	<a href="#">I2C_DMA_TDLR_REG</a>	DMA Transmit Data Level Register
0x50001390	<a href="#">I2C_DMA_RDLR_RE G</a>	I2C Receive Data Level Register
0x50001394	<a href="#">I2C_SDA_SETUP_RE G</a>	I2C SDA Setup Register
0x50001398	<a href="#">I2C_ACK_GENERAL_ CALL_REG</a>	I2C ACK General Call Register
0x5000139C	<a href="#">I2C_ENABLE_STATU S_REG</a>	I2C Enable Status Register
0x500013A0	<a href="#">I2C_IC_FS_SPKLEN_ REG</a>	I2C SS and FS spike suppression limit Size

Table 212: [I2C\\_CON\\_REG](#) (0x50001300)

Bit	Mode	Symbol	Description	Reset
15:7	-	-		0x0
6	R/W	<a href="#">I2C_SLAVE_DISAB LE</a>	Slave enabled or disabled after reset is applied, which means software does not have to configure the slave.  0=slave is enabled 1=slave is disabled  Software should ensure that if this bit is written with '0', then bit 0 should also be written with a '0'.	0x1
5	R/W	<a href="#">I2C_RESTART_EN</a>	Determines whether RESTART conditions may be sent when acting as a master  0= disable 1=enable	0x1
4	R/W	<a href="#">I2C_10BITADDR_M ASTER</a>	Controls whether the controller starts its transfers in 7- or 10-bit addressing mode when acting as a master.  0= 7-bit addressing 1= 10-bit addressing	0x1
3	R/W	<a href="#">I2C_10BITADDR_S LAVE</a>	When acting as a slave, this bit controls whether the controller responds to 7- or 10-bit addresses.  0= 7-bit addressing 1= 10-bit addressing	0x1
2:1	R/W	<a href="#">I2C_SPEED</a>	These bits control at which speed the controller operates.  1= standard mode (100 kbit/s) 2= fast mode (400 kbit/s)	0x2

Bit	Mode	Symbol	Description	Reset
			Note: The actual speed depends on the pcb traces capacitance as well as on the values of the external pull-up resistors. For an exact speed match, trimming might be required, by adjusting the values of I2C_SS_SCL_HCNT_REG, I2C_SS_SCL_LCNT_REG, I2C_FS_SCL_HCNT_REG, I2C_FS_SCL_LCNT_REG registers. The reset values of those registers were calculated with the assumption of 4.3kOhms external pull-up resistors.	
0	R/W	I2C_MASTER_MODE	This bit controls whether the controller master is enabled. 0= master disabled 1= master enabled Software should ensure that if this bit is written with '1' then bit 6 should also be written with a '1'.	0x1

Table 213: I2C\_TAR\_REG (0x50001304)

Bit	Mode	Symbol	Description	Reset
15:12	-	-		0x0
11	R/W	SPECIAL	This bit indicates whether software performs a General Call or START BYTE command. 0: ignore bit 10 GC_OR_START and use IC_TAR normally 1: perform special I2C command as specified in GC_OR_START bit	0x0
10	R/W	GC_OR_START	If bit 11 (SPECIAL) is set to 1, then this bit indicates whether a General Call or START byte command is to be performed by the controller. 0: General Call Address - after issuing a General Call, only writes may be performed. Attempting to issue a read command results in setting bit 6 (TX_ABORT) of the IC_RAW_INTR_STAT register. The controller remains in General Call mode until the SPECIAL bit value (bit 11) is cleared. 1: START BYTE	0x0
9:0	R/W	IC_TAR	This is the target address for any master transaction. When transmitting a General Call, these bits are ignored. To generate a START BYTE, the CPU needs to write only once into these bits. Note: If the IC_TAR and IC_SAR are the same, loopback exists but the FIFOs are shared between master and slave, so full loopback is not feasible. Only one direction loopback mode is supported (simplex), not duplex. A master cannot transmit to itself; it can transmit to only a slave	0x55

Table 214: I2C\_SAR\_REG (0x50001308)

Bit	Mode	Symbol	Description	Reset
15:10	-	-		0x0
9:0	R/W	IC_SAR	The IC_SAR holds the slave address when the I2C is operating as a slave. For 7-bit addressing, only IC_SAR[6:0] is used. This register can be written only when the I2C interface is disabled, which corresponds to the IC_ENABLE register being set to 0. Writes at other times have no effect.	0x55

Table 215: I2C\_DATA\_CMD\_REG (0x50001310)

Bit	Mode	Symbol	Description	Reset
15:11	-	-		0x0
10	R/W	I2C_RESTART	This bit controls whether a RESTART is issued before the byte is sent or received. If IC_RESTART_EN is 1, a RESTART is issued before the data is sent/received (according to the value of CMD), regardless of whether or not the transfer direction is changing from the previous command; if IC_RESTART_EN is 0, a STOP followed by a START is issued instead. If IC_RESTART_EN is 1, a RESTART is issued only if the transfer direction is changing from the previous command; if IC_RESTART_EN is 0, a STOP followed by a START is issued instead. Reset value: 0x0	0x0
9	R/W	I2C_STOP	This bit controls whether a STOP is issued after the byte is sent or received. STOP is issued after this byte, regardless of whether or not the Tx FIFO is empty. If the Tx FIFO is not empty, the master immediately tries to start a new transfer by issuing a START and arbitrating for the bus. STOP is not issued after this byte, regardless of whether or not the Tx FIFO is empty. If the Tx FIFO is not empty, the master continues the current transfer by sending/receiving data bytes according to the value of the CMD bit. If the Tx FIFO is empty, the master holds the SCL line low and stalls the bus until a new command is available in the Tx FIFO. Reset value: 0x0	0x0
8	R/W	I2C_CMD	This bit controls whether a read or a write is performed. This bit does not control the direction when the I2C Ctrl acts as a slave. It controls only the direction when it acts as a master. 1 = Read 0 = Write  When a command is entered in the TX FIFO, this bit distinguishes the write and read commands. In slave-receiver mode, this bit is a "don't care" because writes to this register are not required. In slave-transmitter mode, a "0" indicates that CPU data is to be transmitted and as DAT or IC_DATA_CMD[7:0]. When programming this bit, you should remember the following: attempting to perform a read operation after a General Call	0x0



Bit	Mode	Symbol	Description	Reset
			<p>command has been sent results in a TX_ABRT interrupt (bit 6 of the I2C_RAW_INTR_STAT_REG), unless bit 11 (SPECIAL) in the I2C_TAR register has been cleared.</p> <p>If a "1" is written to this bit after receiving a RD_REQ interrupt, then a TX_ABRT interrupt occurs.</p> <p>NOTE: It is possible that while attempting a master I2C read transfer on the controller, a RD_REQ interrupt may have occurred simultaneously due to a remote I2C master addressing the controller. In this type of scenario, it ignores the I2C_DATA_CMD write, generates a TX_ABRT interrupt, and waits to service the RD_REQ interrupt</p>	
7:0	R/W	DAT	This register contains the data to be transmitted or received on the I2C bus. If you are writing to this register and want to perform a read, bits 7:0 (DAT) are ignored by the controller. However, when you read this register, these bits return the value of data received on the controller's interface.	0x0

Table 216: I2C\_SS\_SCL\_HCNT\_REG (0x50001314)

Bit	Mode	Symbol	Description	Reset
15:0	R/W	IC_SS_SCL_HCNT	<p>This register must be set before any I2C bus transaction can take place to ensure proper I/O timing. This register sets the SCL clock high-period count for standard speed. This register can be written only when the I2C interface is disabled which corresponds to the IC_ENABLE register being set to 0. Writes at other times have no effect.</p> <p>The minimum valid value is 6; hardware prevents values less than this being written, and if attempted results in 6 being set.</p> <p>NOTE: This register must not be programmed to a value higher than 65525, because the controller uses a 16-bit counter to flag an I2C bus idle condition when this counter reaches a value of IC_SS_SCL_HCNT + 10.</p>	0x48

Table 217: I2C\_SS\_SCL\_LCNT\_REG (0x50001318)

Bit	Mode	Symbol	Description	Reset
15:0	R/W	IC_SS_SCL_LCNT	<p>This register must be set before any I2C bus transaction can take place to ensure proper I/O timing. This register sets the SCL clock low period count for standard speed.</p> <p>This register can be written only when the I2C interface is disabled which corresponds to the I2C_ENABLE register being set to 0. Writes at other times have no effect.</p>	0x4F

Bit	Mode	Symbol	Description	Reset
			The minimum valid value is 8; hardware prevents values less than this being written, and if attempted, results in 8 being set.	

Table 218: I2C\_FS\_SCL\_HCNT\_REG (0x5000131C)

Bit	Mode	Symbol	Description	Reset
15:0	R/W	IC_FS_SCL_HCNT	<p>This register must be set before any I2C bus transaction can take place to ensure proper I/O timing. This register sets the SCL clock high-period count for fast speed. It is used in high-speed mode to send the Master Code and START BYTE or General CALL. This register can be written only when the I2C interface is disabled, which corresponds to the I2C_ENABLE register being set to 0. Writes at other times have no effect.</p> <p>The minimum valid value is 6; hardware prevents values less than this being written, and if attempted results in 6 being set.</p>	0x8

Table 219: I2C\_FS\_SCL\_LCNT\_REG (0x50001320)

Bit	Mode	Symbol	Description	Reset
15:0	R/W	IC_FS_SCL_LCNT	<p>This register must be set before any I2C bus transaction can take place to ensure proper I/O timing. This register sets the SCL clock low-period count for fast speed. It is used in high-speed mode to send the Master Code and START BYTE or General CALL. This register can be written only when the I2C interface is disabled, which corresponds to the I2C_ENABLE register being set to 0. Writes at other times have no effect.</p> <p>The minimum valid value is 8; hardware prevents values less than this being written, and if attempted results in 8 being set. For designs with APB_DATA_WIDTH = 8 the order of programming is important to ensure the correct operation of the controller. The lower byte must be programmed first. Then the upper byte is programmed.</p>	0x17

Table 220: I2C\_INTR\_STAT\_REG (0x5000132C)

Bit	Mode	Symbol	Description	Reset
15:12	-	-		0x0
11	R	R_GEN_CALL	Set only when a General Call address is received and it is acknowledged. It stays set until it is cleared either by disabling controller or when the CPU reads bit 0 of the I2C_CLR_GEN_CALL register. The controller stores the received data in the Rx buffer.	0x0
10	R	R_START_DET	Indicates whether a START or RESTART condition has occurred on the I2C interface	0x0

Bit	Mode	Symbol	Description	Reset
			regardless of whether controller is operating in slave or master mode.	
9	R	R_STOP_DET	Indicates whether a STOP condition has occurred on the I2C interface regardless of whether controller is operating in slave or master mode.	0x0
8	R	R_ACTIVITY	This bit captures I2C Ctrl activity and stays set until it is cleared. There are four ways to clear it: => Disabling the I2C Ctrl => Reading the IC_CLR_ACTIVITY register => Reading the IC_CLR_INTR register => System reset Once this bit is set, it stays set unless one of the four methods is used to clear it. Even if the controller module is idle, this bit remains set until cleared, indicating that there was activity on the bus.	0x0
7	R	R_RX_DONE	When the controller is acting as a slave-transmitter, this bit is set to 1 if the master does not acknowledge a transmitted byte. This occurs on the last byte of the transmission, indicating that the transmission is done.	0x0
6	R	R_TX_ABRT	This bit indicates if the controller, as an I2C transmitter, is unable to complete the intended actions on the contents of the transmit FIFO. This situation can occur both as an I2C master or an I2C slave, and is referred to as a "transmit abort". When this bit is set to 1, the I2C_TX_ABRT_SOURCE register indicates the reason why the transmit abort takes places. NOTE: The controller flushes/resets/empties the TX FIFO whenever this bit is set. The TX FIFO remains in this flushed state until the register I2C_CLR_TX_ABRT is read. Once this read is performed, the TX FIFO is then ready to accept more data bytes from the APB interface.	0x0
5	R	R_RD_REQ	This bit is set to 1 when the controller is acting as a slave and another I2C master is attempting to read data from the controller. The controller holds the I2C bus in a wait state (SCL=0) until this interrupt is serviced, which means that the slave has been addressed by a remote master that is asking for data to be transferred. The processor must respond to this interrupt and then write the requested data to the I2C_DATA_CMD register. This bit is set to 0 just after the processor reads the I2C_CLR_RD_REQ register	0x0
4	R	R_TX_EMPTY	This bit is set to 1 when the transmit buffer is at or below the threshold value set in the I2C_TX_TL register. It is automatically cleared by hardware when the buffer level goes above the threshold. When the IC_ENABLE bit 0 is 0, the TX FIFO is flushed and held in reset. There the TX FIFO looks like it has no data within it, so this bit is set to 1, provided there is activity in the master or slave state machines. When there is no longer activity, then with ic_en=0, this bit is set to 0.	0x0

Bit	Mode	Symbol	Description	Reset
3	R	R_TX_OVER	Set during transmit if the transmit buffer is filled to 32 and the processor attempts to issue another I2C command by writing to the IC_DATA_CMD register. When the module is disabled, this bit keeps its level until the master or slave state machines go into idle, and when ic_en goes to 0, this interrupt is cleared	0x0
2	R	R_RX_FULL	Set when the receive buffer reaches or goes above the RX_TL threshold in the I2C_RX_TL register. It is automatically cleared by hardware when buffer level goes below the threshold. If the module is disabled (I2C_ENABLE[0]=0), the RX FIFO is flushed and held in reset; therefore the RX FIFO is not full. So this bit is cleared once the I2C_ENABLE bit 0 is programmed with a 0, regardless of the activity that continues.	0x0
1	R	R_RX_OVER	Set if the receive buffer is completely filled to 32 and an additional byte is received from an external I2C device. The controller acknowledges this, but any data bytes received after the FIFO is full are lost. If the module is disabled (I2C_ENABLE[0]=0), this bit keeps its level until the master or slave state machines go into idle, and when ic_en goes to 0, this interrupt is cleared.	0x0
0	R	R_RX_UNDER	Set if the processor attempts to read the receive buffer when it is empty by reading from the IC_DATA_CMD register. If the module is disabled (I2C_ENABLE[0]=0), this bit keeps its level until the master or slave state machines go into idle, and when ic_en goes to 0, this interrupt is cleared.	0x0

Table 221: I2C\_INTR\_MASK\_REG (0x50001330)

Bit	Mode	Symbol	Description	Reset
15:12	-	-		0x0
11	R/W	M_GEN_CALL	These bits mask their corresponding interrupt status bits in the I2C_INTR_STAT register.	0x1
10	R/W	M_START_DET	These bits mask their corresponding interrupt status bits in the I2C_INTR_STAT register.	0x0
9	R/W	M_STOP_DET	These bits mask their corresponding interrupt status bits in the I2C_INTR_STAT register.	0x0
8	R/W	M_ACTIVITY	These bits mask their corresponding interrupt status bits in the I2C_INTR_STAT register.	0x0
7	R/W	M_RX_DONE	These bits mask their corresponding interrupt status bits in the I2C_INTR_STAT register.	0x1
6	R/W	M_TX_ABRT	These bits mask their corresponding interrupt status bits in the I2C_INTR_STAT register.	0x1
5	R/W	M_RD_REQ	These bits mask their corresponding interrupt status bits in the I2C_INTR_STAT register.	0x1
4	R/W	M_TX_EMPTY	These bits mask their corresponding interrupt status bits in the I2C_INTR_STAT register.	0x1

Bit	Mode	Symbol	Description	Reset
3	R/W	M_TX_OVER	These bits mask their corresponding interrupt status bits in the I2C_INTR_STAT register.	0x1
2	R/W	M_RX_FULL	These bits mask their corresponding interrupt status bits in the I2C_INTR_STAT register.	0x1
1	R/W	M_RX_OVER	These bits mask their corresponding interrupt status bits in the I2C_INTR_STAT register.	0x1
0	R/W	M_RX_UNDER	These bits mask their corresponding interrupt status bits in the I2C_INTR_STAT register.	0x1

Table 222: I2C\_RAW\_INTR\_STAT\_REG (0x50001334)

Bit	Mode	Symbol	Description	Reset
15:12	-	-		0x0
11	R	GEN_CALL	Set only when a General Call address is received and it is acknowledged. It stays set until it is cleared either by disabling controller or when the CPU reads bit 0 of the I2C_CLR_GEN_CALL register. I2C Ctrl stores the received data in the Rx buffer.	0x0
10	R	START_DET	Indicates whether a START or RESTART condition has occurred on the I2C interface regardless of whether controller is operating in slave or master mode.	0x0
9	R	STOP_DET	Indicates whether a STOP condition has occurred on the I2C interface regardless of whether controller is operating in slave or master mode.	0x0
8	R	ACTIVITY	This bit captures I2C Ctrl activity and stays set until it is cleared. There are four ways to clear it: => Disabling the I2C Ctrl => Reading the IC_CLR_ACTIVITY register => Reading the IC_CLR_INTR register => System reset Once this bit is set, it stays set unless one of the four methods is used to clear it. Even if the controller module is idle, this bit remains set until cleared, indicating that there was activity on the bus.	0x0
7	R	RX_DONE	When the controller is acting as a slave-transmitter, this bit is set to 1 if the master does not acknowledge a transmitted byte. This occurs on the last byte of the transmission, indicating that the transmission is done.	0x0
6	R	TX_ABRT	This bit indicates if the controller, as an I2C transmitter, is unable to complete the intended actions on the contents of the transmit FIFO. This situation can occur both as an I2C master or an I2C slave, and is referred to as a "transmit abort". When this bit is set to 1, the I2C_TX_ABRT_SOURCE register indicates the reason why the transmit abort takes places. NOTE: The controller flushes/resets/empties the TX FIFO whenever this bit is set. The TX FIFO remains in this flushed state until the register	0x0

Bit	Mode	Symbol	Description	Reset
			I2C_CLR_TX_ABRT is read. Once this read is performed, the TX FIFO is then ready to accept more data bytes from the APB interface.	
5	R	RD_REQ	This bit is set to 1 when I2C Ctrl is acting as a slave and another I2C master is attempting to read data from the controller. The controller holds the I2C bus in a wait state (SCL=0) until this interrupt is serviced, which means that the slave has been addressed by a remote master that is asking for data to be transferred. The processor must respond to this interrupt and then write the requested data to the I2C_DATA_CMD register. This bit is set to 0 just after the processor reads the I2C_CLR_RD_REQ register	0x0
4	R	TX_EMPTY	This bit is set to 1 when the transmit buffer is at or below the threshold value set in the I2C_TX_TL register. It is automatically cleared by hardware when the buffer level goes above the threshold. When the IC_ENABLE bit 0 is 0, the TX FIFO is flushed and held in reset. There the TX FIFO looks like it has no data within it, so this bit is set to 1, provided there is activity in the master or slave state machines. When there is no longer activity, then with ic_en=0, this bit is set to 0.	0x0
3	R	TX_OVER	Set during transmit if the transmit buffer is filled to 32 and the processor attempts to issue another I2C command by writing to the IC_DATA_CMD register. When the module is disabled, this bit keeps its level until the master or slave state machines go into idle, and when ic_en goes to 0, this interrupt is cleared	0x0
2	R	RX_FULL	Set when the receive buffer reaches or goes above the RX_TL threshold in the I2C_RX_TL register. It is automatically cleared by hardware when buffer level goes below the threshold. If the module is disabled (I2C_ENABLE[0]=0), the RX FIFO is flushed and held in reset; therefore the RX FIFO is not full. So this bit is cleared once the I2C_ENABLE bit 0 is programmed with a 0, regardless of the activity that continues.	0x0
1	R	RX_OVER	Set if the receive buffer is completely filled to 32 and an additional byte is received from an external I2C device. The controller acknowledges this, but any data bytes received after the FIFO is full are lost. If the module is disabled (I2C_ENABLE[0]=0), this bit keeps its level until the master or slave state machines go into idle, and when ic_en goes to 0, this interrupt is cleared.	0x0
0	R	RX_UNDER	Set if the processor attempts to read the receive buffer when it is empty by reading from the IC_DATA_CMD register. If the module is disabled (I2C_ENABLE[0]=0), this bit keeps its level until the master or slave state machines go into idle, and when ic_en goes to 0, this interrupt is cleared.	0x0

Table 223: I2C\_RX\_TL\_REG (0x50001338)

Bit	Mode	Symbol	Description	Reset
15:5	-	-		0x0
4:0	R/W	RX_TL	Receive FIFO Threshold Level Controls the level of entries (or above) that triggers the RX_FULL interrupt (bit 2 in I2C_RAW_INTR_STAT register). The valid range is 0-31, with the additional restriction that hardware does not allow this value to be set to a value larger than the depth of the buffer. If an attempt is made to do that, the actual value set will be the maximum depth of the buffer. A value of 0 sets the threshold for 1 entry, and a value of 31 sets the threshold for 32 entries.	0x0

Table 224: I2C\_TX\_TL\_REG (0x5000133C)

Bit	Mode	Symbol	Description	Reset
15:5	-	-		0x0
4:0	R/W	RX_TL	Transmit FIFO Threshold Level Controls the level of entries (or below) that trigger the TX_EMPTY interrupt (bit 4 in I2C_RAW_INTR_STAT register). The valid range is 0-31, with the additional restriction that it may not be set to value larger than the depth of the buffer. If an attempt is made to do that, the actual value set will be the maximum depth of the buffer. A value of 0 sets the threshold for 0 entries, and a value of 31 sets the threshold for 32 entries..	0x0

Table 225: I2C\_CLR\_INTR\_REG (0x50001340)

Bit	Mode	Symbol	Description	Reset
15:1	-	-		0x0
0	R	CLR_INTR	Read this register to clear the combined interrupt, all individual interrupts, and the I2C_TX_ABRT_SOURCE register. This bit does not clear hardware clearable interrupts but software clearable interrupts. Refer to Bit 9 of the I2C_TX_ABRT_SOURCE register for an exception to clearing I2C_TX_ABRT_SOURCE	0x0

Table 226: I2C\_CLR\_RX\_UNDER\_REG (0x50001344)

Bit	Mode	Symbol	Description	Reset
15:1	-	-		0x0
0	R	CLR_RX_UNDER	Read this register to clear the RX_UNDER interrupt (bit 0) of the I2C_RAW_INTR_STAT register.	0x0

Table 227: I2C\_CLR\_RX\_OVER\_REG (0x50001348)

Bit	Mode	Symbol	Description	Reset
15:1	-	-		0x0
0	R	CLR_RX_OVER	Read this register to clear the RX_OVER interrupt (bit 1) of the I2C_RAW_INTR_STAT register.	0x0

Table 228: I2C\_CLR\_TX\_OVER\_REG (0x5000134C)

Bit	Mode	Symbol	Description	Reset
15:1	-	-		0x0
0	R	CLR_TX_OVER	Read this register to clear the TX_OVER interrupt (bit 3) of the I2C_RAW_INTR_STAT register.	0x0

Table 229: I2C\_CLR\_RD\_REQ\_REG (0x50001350)

Bit	Mode	Symbol	Description	Reset
15:1	-	-		0x0
0	R	CLR_RD_REQ	Read this register to clear the RD_REQ interrupt (bit 5) of the I2C_RAW_INTR_STAT register.	0x0

Table 230: I2C\_CLR\_TX\_ABRT\_REG (0x50001354)

Bit	Mode	Symbol	Description	Reset
15:1	-	-		0x0
0	R	CLR_TX_ABRT	Read this register to clear the TX_ABRT interrupt (bit 6) of the IC_RAW_INTR_STAT register, and the I2C_TX_ABRT_SOURCE register. This also releases the TX FIFO from the flushed/reset state, allowing more writes to the TX FIFO. Refer to Bit 9 of the I2C_TX_ABRT_SOURCE register for an exception to clearing IC_TX_ABRT_SOURCE.	0x0

Table 231: I2C\_CLR\_RX\_DONE\_REG (0x50001358)

Bit	Mode	Symbol	Description	Reset
15:1	-	-		0x0
0	R	CLR_RX_DONE	Read this register to clear the RX_DONE interrupt (bit 7) of the I2C_RAW_INTR_STAT register.	0x0



Table 232: I2C\_CLR\_ACTIVITY\_REG (0x5000135C)

Bit	Mode	Symbol	Description	Reset
15:1	-	-		0x0
0	R	CLR_ACTIVITY	Reading this register clears the ACTIVITY interrupt if the I2C is not active anymore. If the I2C module is still active on the bus, the ACTIVITY interrupt bit continues to be set. It is automatically cleared by hardware if the module is disabled and if there is no further activity on the bus. The value read from this register to get status of the ACTIVITY interrupt (bit 8) of the IC_RAW_INTR_STAT register	0x0

Table 233: I2C\_CLR\_STOP\_DET\_REG (0x50001360)

Bit	Mode	Symbol	Description	Reset
15:1	-	-		0x0
0	R	CLR_STOP_DET	Read this register to clear the STOP_DET interrupt (bit 9) of the IC_RAW_INTR_STAT register. Reset value: 0x0	0x0

Table 234: I2C\_CLR\_START\_DET\_REG (0x50001364)

Bit	Mode	Symbol	Description	Reset
15:1	-	-		0x0
0	R	CLR_START_DET	Read this register to clear the START_DET interrupt (bit 10) of the IC_RAW_INTR_STAT register.	0x0

Table 235: I2C\_CLR\_GEN\_CALL\_REG (0x50001368)

Bit	Mode	Symbol	Description	Reset
15:1	-	-		0x0
0	R	CLR_GEN_CALL	Read this register to clear the GEN_CALL interrupt (bit 11) of I2C_RAW_INTR_STAT register.	0x0

Table 236: I2C\_ENABLE\_REG (0x5000136C)

Bit	Mode	Symbol	Description	Reset
15:2	-	-		0x0
1	R/W	I2C_ABORT	0= ABORT not initiated or ABORT done 1= ABORT operation in progress  The software can abort the I2C transfer in master mode by setting this bit. The software can set this bit only when ENABLE is already set; otherwise, the controller ignores any write to ABORT bit. The	0x0

Bit	Mode	Symbol	Description	Reset
			software cannot clear the ABORT bit once set. In response to an ABORT, the controller issues a STOP and flushes the Tx FIFO after completing the current transfer, then sets the TX_ABORT interrupt after the abort operation. The ABORT bit is cleared automatically after the abort operation.	
0	R/W	CTRL_ENABLE	<p>Controls whether the controller is enabled.</p> <p>0: Disables the controller (TX and RX FIFOs are held in an erased state)</p> <p>1: Enables the controller</p> <p>Software can disable the controller while it is active. However, it is important that care be taken to ensure that the controller is disabled properly. When the controller is disabled, the following occurs:</p> <ul style="list-style-type: none"> <li>* The TX FIFO and RX FIFO get flushed.</li> <li>* Status bits in the IC_INTR_STAT register are still active until the controller goes into IDLE state.</li> </ul> <p>If the module is transmitting, it stops as well as deletes the contents of the transmit buffer after the current transfer is complete. If the module is receiving, the controller stops the current transfer at the end of the current byte and does not acknowledge the transfer.</p> <p>There is a two ic_clk delay when enabling or disabling the controller</p>	0x0

Table 237: I2C\_STATUS\_REG (0x50001370)

Bit	Mode	Symbol	Description	Reset
15:7	-	-		0x0
6	R	SLV_ACTIVITY	<p>Slave FSM Activity Status. When the Slave Finite State Machine (FSM) is not in the IDLE state, this bit is set.</p> <p>0: Slave FSM is in IDLE state so the Slave part of the controller is not Active</p> <p>1: Slave FSM is not in IDLE state so the Slave part of the controller is Active</p>	0x0
5	R	MST_ACTIVITY	<p>Master FSM Activity Status. When the Master Finite State Machine (FSM) is not in the IDLE state, this bit is set.</p> <p>0: Master FSM is in IDLE state so the Master part of the controller is not Active</p> <p>1: Master FSM is not in IDLE state so the Master part of the controller is Active</p>	0x0
4	R	RFF	<p>Receive FIFO Completely Full. When the receive FIFO is completely full, this bit is set. When the receive FIFO contains one or more empty location, this bit is cleared.</p> <p>0: Receive FIFO is not full</p> <p>1: Receive FIFO is full</p>	0x0

Bit	Mode	Symbol	Description	Reset
3	R	RFNE	Receive FIFO Not Empty. This bit is set when the receive FIFO contains one or more entries; it is cleared when the receive FIFO is empty. 0: Receive FIFO is empty 1: Receive FIFO is not empty	0x0
2	R	TFE	Transmit FIFO Completely Empty. When the transmit FIFO is completely empty, this bit is set. When it contains one or more valid entries, this bit is cleared. This bit field does not request an interrupt. 0: Transmit FIFO is not empty 1: Transmit FIFO is empty	0x1
1	R	TFNF	Transmit FIFO Not Full. Set when the transmit FIFO contains one or more empty locations, and is cleared when the FIFO is full. 0: Transmit FIFO is full 1: Transmit FIFO is not full	0x1
0	R	I2C_ACTIVITY	I2C Activity Status.	0x0

Table 238: I2C\_TXFLR\_REG (0x50001374)

Bit	Mode	Symbol	Description	Reset
15:6	-	-		0x0
5:0	R	TXFLR	Transmit FIFO Level. Contains the number of valid data entries in the transmit FIFO. Size is constrained by the TXFLR value	0x0

Table 239: I2C\_RXFLR\_REG (0x50001378)

Bit	Mode	Symbol	Description	Reset
15:6	-	-		0x0
5:0	R	RXFLR	Receive FIFO Level. Contains the number of valid data entries in the receive FIFO. Size is constrained by the RXFLR value	0x0

Table 240: I2C\_SDA\_HOLD\_REG (0x5000137C)

Bit	Mode	Symbol	Description	Reset
15:0	R/W	IC_SDA_HOLD	SDA Hold time	0x1

Table 241: I2C\_TX\_ABRT\_SOURCE\_REG (0x50001380)

Bit	Mode	Symbol	Description	Reset
15	R	ABRT_SLVRD_INT X	1: When the processor side responds to a slave mode request for data to be transmitted to a	0x0

Bit	Mode	Symbol	Description	Reset
			remote master and user writes a 1 in CMD (bit 8) of 2IC_DATA_CMD register	
14	R	ABRT_SLV_ARBLOST	1: Slave lost the bus while transmitting data to a remote master. I2C_TX_ABRT_SOURCE[12] is set at the same time. Note: Even though the slave never "owns" the bus, something could go wrong on the bus. This is a fail safe check. For instance, during a data transmission at the low-to-high transition of SCL, if what is on the data bus is not what is supposed to be transmitted, then the controller no longer own the bus.	0x0
13	R	ABRT_SLVFLUSH_TXFIFO	1: Slave has received a read command and some data exists in the TX FIFO so the slave issues a TX_ABRT interrupt to flush old data in TX FIFO.	0x0
12	R	ARB_LOST	1: Master has lost arbitration, or if I2C_TX_ABRT_SOURCE[14] is also set, then the slave transmitter has lost arbitration. Note: I2C can be both master and slave at the same time.	0x0
11	R	ABRT_MASTER_DISABLE	1: User tries to initiate a Master operation with the Master mode disabled.	0x0
10	R	ABRT_10B_RD_NORSTR	1: The restart is disabled (IC_RESTART_EN bit (I2C_CON[5]) = 0) and the master sends a read command in 10-bit addressing mode.	0x0
9	R	ABRT_SBYTE_NORSTR	To clear Bit 9, the source of the ABRT_SBYTE_NORSTR must be fixed first; restart must be enabled (I2C_CON[5]=1), the SPECIAL bit must be cleared (I2C_TAR[11]), or the GC_OR_START bit must be cleared (I2C_TAR[10]). Once the source of the ABRT_SBYTE_NORSTR is fixed, then this bit can be cleared in the same manner as other bits in this register. If the source of the ABRT_SBYTE_NORSTR is not fixed before attempting to clear this bit, bit 9 clears for one cycle and then gets re-asserted. 1: The restart is disabled (IC_RESTART_EN bit (I2C_CON[5]) = 0) and the user is trying to send a START Byte.	0x0
8	R	ABRT_HS_NORSTR	1: The restart is disabled (IC_RESTART_EN bit (I2C_CON[5]) = 0) and the user is trying to use the master to transfer data in High Speed mode	0x0
7	R	ABRT_SBYTE_ACKDET	1: Master has sent a START Byte and the START Byte was acknowledged (wrong behavior).	0x0
6	R	ABRT_HS_ACKDET	1: Master is in High Speed mode and the High Speed Master code was acknowledged (wrong behavior).	0x0
5	R	ABRT_GCALL_READ	1: the controller in master mode sent a General Call but the user programmed the byte following the General Call to be a read from the bus (IC_DATA_CMD[9] is set to 1).	0x0
4	R	ABRT_GCALL_NOACK	1: the controller in master mode sent a General Call and no slave on the bus acknowledged the General Call.	0x0
3	R	ABRT_TXDATA_NOACK	1: This is a master-mode only bit. Master has received an acknowledgement for the address, but when it sent data byte(s) following the address, it	0x0

Bit	Mode	Symbol	Description	Reset
			did not receive an acknowledge from the remote slave(s).	
2	R	ABRT_10ADDR2_N OACK	1: Master is in 10-bit address mode and the second address byte of the 10-bit address was not acknowledged by any slave.	0x0
1	R	ABRT_10ADDR1_N OACK	1: Master is in 10-bit address mode and the first 10-bit address byte was not acknowledged by any slave.	0x0
0	R	ABRT_7B_ADDR_N OACK	1: Master is in 7-bit addressing mode and the address sent was not acknowledged by any slave.	0x0

Table 242: I2C\_DMA\_CR\_REG (0x50001388)

Bit	Mode	Symbol	Description	Reset
1	R/W	TDMAE	Transmit DMA Enable. //This bit enables/disables the transmit FIFO DMA channel. 0 = Transmit DMA disabled 1 = Transmit DMA enabled	0x0
0	R/W	RDMAE	Receive DMA Enable. This bit enables/disables the receive FIFO DMA channel. 0 = Receive DMA disabled 1 = Receive DMA enabled	0x0

Table 243: I2C\_DMA\_TDLR\_REG (0x5000138C)

Bit	Mode	Symbol	Description	Reset
4:0	R/W	DMATDL	Transmit Data Level. This bit field controls the level at which a DMA request is made by the transmit logic. It is equal to the watermark level; that is, the dma_tx_req signal is generated when the number of valid data entries in the transmit FIFO is equal to or below this field value, and TDMAE = 1.	0x0

Table 244: I2C\_DMA\_RDLR\_REG (0x50001390)

Bit	Mode	Symbol	Description	Reset
4:0	R/W	DMARDL	Receive Data Level. This bit field controls the level at which a DMA request is made by the receive logic. The watermark level = DMARDL+1; that is, dma_rx_req is generated when the number of valid data entries in the receive FIFO is equal to or more than this field value + 1, and RDMAE =1. For instance, when DMARDL is 0, then dma_rx_req is asserted when 1 or more data entries are present in the receive FIFO.	0x0

Table 245: I2C\_SDA\_SETUP\_REG (0x50001394)

Bit	Mode	Symbol	Description	Reset
15:8	-	-		0x0

Bit	Mode	Symbol	Description	Reset
7:0	R/W	SDA_SETUP	<p>SDA Setup.</p> <p>This register controls the amount of time delay (number of I2C clock periods) between the rising edge of SCL and SDA changing by holding SCL low when I2C block services a read request while operating as a slave-transmitter. The relevant I2C requirement is tSU:DAT (note 4) as detailed in the I2C Bus Specification. This register must be programmed with a value equal to or greater than 2.</p> <p>It is recommended that if the required delay is 100ns, then for an I2C frequency of 10 MHz, IC_SDA_SETUP should be programmed to a value of 11. Writes to this register succeed only when IC_ENABLE[0] = 0.</p>	0x64

Table 246: I2C\_ACK\_GENERAL\_CALL\_REG (0x50001398)

Bit	Mode	Symbol	Description	Reset
15:1	-	-		0x0
0	R/W	ACK_GEN_CALL	ACK General Call. When set to 1, I2C Ctrl responds with a ACK (by asserting ic_data_oe) when it receives a General Call. When set to 0, the controller does not generate General Call interrupts.	0x0

Table 247: I2C\_ENABLE\_STATUS\_REG (0x5000139C)

Bit	Mode	Symbol	Description	Reset
15:3	-	-		0x0
2	R	SLV_RX_DATA_LOST	<p>Slave Received Data Lost. This bit indicates if a Slave-Receiver operation has been aborted with at least one data byte received from an I2C transfer due to the setting of IC_ENABLE from 1 to 0. When read as 1, the controller is deemed to have been actively engaged in an aborted I2C transfer (with matching address) and the data phase of the I2C transfer has been entered, even though a data byte has been responded with a NACK. NOTE: If the remote I2C master terminates the transfer with a STOP condition before the controller has a chance to NACK a transfer, and IC_ENABLE has been set to 0, then this bit is also set to 1.</p> <p>When read as 0, the controller is deemed to have been disabled without being actively involved in the data phase of a Slave-Receiver transfer.</p> <p>NOTE: The CPU can safely read this bit when IC_EN (bit 0) is read as 0.</p>	0x0
1	R	SLV_DISABLED_WHILE_BUSY	Slave Disabled While Busy (Transmit, Receive). This bit indicates if a potential or active Slave operation has been aborted due to the setting of the IC_ENABLE register from 1 to 0. This bit is set	0x0

Bit	Mode	Symbol	Description	Reset
			<p>when the CPU writes a 0 to the IC_ENABLE register while:</p> <p>(a) I2C Ctrl is receiving the address byte of the Slave-Transmitter operation from a remote master; OR,</p> <p>(b) address and data bytes of the Slave-Receiver operation from a remote master. When read as 1, the controller is deemed to have forced a NACK during any part of an I2C transfer, irrespective of whether the I2C address matches the slave address set in I2C Ctrl (IC_SAR register) OR if the transfer is completed before IC_ENABLE is set to 0 but has not taken effect.</p> <p>NOTE: If the remote I2C master terminates the transfer with a STOP condition before the the controller has a chance to NACK a transfer, and IC_ENABLE has been set to 0, then this bit will also be set to 1.</p> <p>When read as 0, the controller is deemed to have been disabled when there is master activity, or when the I2C bus is idle.</p> <p>NOTE: The CPU can safely read this bit when IC_EN (bit 0) is read as 0.</p>	
0	R	IC_EN	<p>ic_en Status. This bit always reflects the value driven on the output port ic_en. When read as 1, the controller is deemed to be in an enabled state.</p> <p>When read as 0, the controller is deemed completely inactive.</p> <p>NOTE: The CPU can safely read this bit anytime. When this bit is read as 0, the CPU can safely read SLV_RX_DATA_LOST (bit 2) and SLV_DISABLED_WHILE_BUSY (bit 1).</p>	0x0

Table 248: I2C\_IC\_FS\_SPKLEN\_REG (0x500013A0)

Bit	Mode	Symbol	Description	Reset
15:8	-	-		0x0
7:0	R/W	IC_FS_SPKLEN	<p>This register must be set before any I2C bus transaction can take place to ensure stable operation. This register sets the duration, measured in ic_clk cycles, of the longest spike in the SCL or SDA lines that will be filtered out by the spike suppression logic. This register can be written only when the I2C interface is disabled which corresponds to the IC_ENABLE register being set to 0. Writes at other times have no effect. The minimum valid value is 1; hardware prevents values less than this being written, and if attempted results in 1 being set.</p>	0x1

## 31.9 Keyboard Registers

**Table 249: Register map KBRD**

Address	Register	Description
0x50001400	<a href="#">GPIO_IRQ0_IN_SEL_REG</a>	GPIO interrupt selection for GPIO_IRQ0
0x50001402	<a href="#">GPIO_IRQ1_IN_SEL_REG</a>	GPIO interrupt selection for GPIO_IRQ1
0x50001404	<a href="#">GPIO_IRQ2_IN_SEL_REG</a>	GPIO interrupt selection for GPIO_IRQ2
0x50001406	<a href="#">GPIO_IRQ3_IN_SEL_REG</a>	GPIO interrupt selection for GPIO_IRQ3
0x50001408	<a href="#">GPIO_IRQ4_IN_SEL_REG</a>	GPIO interrupt selection for GPIO_IRQ4
0x5000140C	<a href="#">GPIO_DEBOUNCE_REG</a>	debounce counter value for GPIO inputs
0x5000140E	<a href="#">GPIO_RESET_IRQ_REG</a>	GPIO interrupt reset register
0x50001410	<a href="#">GPIO_INT_LEVEL_CTRL_REG</a>	high or low level select for GPIO interrupts
0x50001412	<a href="#">KBRD_IRQ_IN_SEL0_REG</a>	GPIO interrupt selection for KBRD_IRQ for P0
0x50001414	<a href="#">KBRD_CTRL_REG</a>	GPIO Kbrd control register

**Table 250: [GPIO\\_IRQ0\\_IN\\_SEL\\_REG](#) (0x50001400)**

Bit	Mode	Symbol	Description	Reset
15:6	-	-		0x0
3:0	R/W	KBRD_IRQ0_SEL	input selection that can generate a GPIO interrupt 1: P0[0] is selected 2: P0[1] is selected 3: P0[2] is selected 4: P0[3] is selected 5: P0[4] is selected 6: P0[5] is selected 7: P0[6] is selected 8: P0[7] is selected 9: P0[8] is selected 10: P0[9] is selected 11: P0[10] is selected 12: P0[11] is selected all others: no input selected	0x0



Table 251: GPIO\_IRQ1\_IN\_SEL\_REG (0x50001402)

Bit	Mode	Symbol	Description	Reset
15:6	-	-		0x0
3:0	R/W	KBRD_IRQ1_SEL	see KBRD_IRQ0_SEL	0x0

Table 252: GPIO\_IRQ2\_IN\_SEL\_REG (0x50001404)

Bit	Mode	Symbol	Description	Reset
15:6	-	-		0x0
3:0	R/W	KBRD_IRQ2_SEL	see KBRD_IRQ0_SEL	0x0

Table 253: GPIO\_IRQ3\_IN\_SEL\_REG (0x50001406)

Bit	Mode	Symbol	Description	Reset
15:6	-	-		0x0
3:0	R/W	KBRD_IRQ3_SEL	see KBRD_IRQ0_SEL	0x0

Table 254: GPIO\_IRQ4\_IN\_SEL\_REG (0x50001408)

Bit	Mode	Symbol	Description	Reset
15:6	-	-		0x0
3:0	R/W	KBRD_IRQ4_SEL	see KBRD_IRQ0_SEL	0x0

Table 255: GPIO\_DEBOUNCE\_REG (0x5000140C)

Bit	Mode	Symbol	Description	Reset
11	R/W	DEB_ENABLE_KBRD	enables the debounce counter for the KBRD interface	0x0
10	R/W	DEB_ENABLE4	enables the debounce counter for GPIO IRQ4	0x0
9	R/W	DEB_ENABLE3	enables the debounce counter for GPIO IRQ3	0x0
8	R/W	DEB_ENABLE2	enables the debounce counter for GPIO IRQ2	0x0
7	R/W	DEB_ENABLE1	enables the debounce counter for GPIO IRQ1	0x0
6	R/W	DEB_ENABLE0	enables the debounce counter for GPIO IRQ0	0x0
5:0	R/W	DEB_VALUE	Keyboard debounce time if enabled. Generate KEYB_INT after specified time. Debounce time: $N * 1 \text{ ms}$ . $N = 0..63$	0x0

Table 256: GPIO\_RESET\_IRQ\_REG (0x5000140E)

Bit	Mode	Symbol	Description	Reset
15:6	-	-		0x0

Bit	Mode	Symbol	Description	Reset
5	R0/W	RESET_KBRD_IRQ	writing a 1 to this bit will reset the KBRD IRQ. Reading returns 0.	0x0
4	R0/W	RESET_GPIO4_IRQ	writing a 1 to this bit will reset the GPIO4 IRQ. Reading returns 0.	0x0
3	R0/W	RESET_GPIO3_IRQ	writing a 1 to this bit will reset the GPIO3 IRQ. Reading returns 0.	0x0
2	R0/W	RESET_GPIO2_IRQ	writing a 1 to this bit will reset the GPIO2 IRQ. Reading returns 0.	0x0
1	R0/W	RESET_GPIO1_IRQ	writing a 1 to this bit will reset the GPIO1 IRQ. Reading returns 0.	0x0
0	R0/W	RESET_GPIO0_IRQ	writing a 1 to this bit will reset the GPIO0 IRQ. Reading returns 0.	0x0

Table 257: GPIO\_INT\_LEVEL\_CTRL\_REG (0x50001410)

Bit	Mode	Symbol	Description	Reset
9	R/W	EDGE_LEVELn4	see EDGE_LEVELn0, but for GPIO IRQ4	0x0
8	R/W	EDGE_LEVELn3	see EDGE_LEVELn0, but for GPIO IRQ3	0x0
7	R/W	EDGE_LEVELn2	see EDGE_LEVELn0, but for GPIO IRQ2	0x0
6	R/W	EDGE_LEVELn1	see EDGE_LEVELn0, but for GPIO IRQ1	0x0
5	R/W	EDGE_LEVELn0	0: do not wait for key release after interrupt was reset for GPIO IRQ0, so a new interrupt can be initiated immediately 1: wait for key release after interrupt was reset for IRQ0	0x0
4	R/W	INPUT_LEVEL4	see INPUT_LEVEL0, but for GPIO IRQ4	0x0
3	R/W	INPUT_LEVEL3	see INPUT_LEVEL0, but for GPIO IRQ3	0x0
2	R/W	INPUT_LEVEL2	see INPUT_LEVEL0, but for GPIO IRQ2	0x0
1	R/W	INPUT_LEVEL1	see INPUT_LEVEL0, but for GPIO IRQ1	0x0
0	R/W	INPUT_LEVEL0	0 = selected input will generate GPIO IRQ0 if that input is high. 1 = selected input will generate GPIO IRQ0 if that input is low.	0x0

Table 258: KBRD\_IRQ\_IN\_SEL0\_REG (0x50001412)

Bit	Mode	Symbol	Description	Reset
11	R/W	KBRD_P11_EN	enable P0[11] for the keyboard interrupt	0x0
10	R/W	KBRD_P10_EN	enable P0[10] for the keyboard interrupt	0x0
9	R/W	KBRD_P09_EN	enable P0[9] for the keyboard interrupt	0x0
8	R/W	KBRD_P08_EN	enable P0[8] for the keyboard interrupt	0x0
7	R/W	KBRD_P07_EN	enable P0[7] for the keyboard interrupt	0x0
6	R/W	KBRD_P06_EN	enable P0[6] for the keyboard interrupt	0x0

Bit	Mode	Symbol	Description	Reset
5	R/W	KBRD_P05_EN	enable P0[5] for the keyboard interrupt	0x0
4	R/W	KBRD_P04_EN	enable P0[4] for the keyboard interrupt	0x0
3	R/W	KBRD_P03_EN	enable P0[3] for the keyboard interrupt	0x0
2	R/W	KBRD_P02_EN	enable P0[2] for the keyboard interrupt	0x0
1	R/W	KBRD_P01_EN	enable P0[1] for the keyboard interrupt	0x0
0	R/W	KBRD_P00_EN	enable P0[0] for the keyboard interrupt	0x0

Table 259: **KBRD\_CTRL\_REG (0x50001414)**

Bit	Mode	Symbol	Description	Reset
7	R/W	KBRD_REL	0 = No interrupt on key release 1 = Interrupt also on key release (also debouncing if enabled)	0x0
6	R/W	KBRD_LEVEL	0 = enabled input will generate KBRD IRQ if that input is high. 1 = enabled input will generate KBRD IRQ if that input is low.	0x0
5:0	R/W	KEY_REPEAT	While key is pressed, automatically generate repeating KEYB_INT after specified time unequal to 0. Repeat time: N*1 ms. N = 1..63, N=0 disables the timer.	0x0

## 31.10 Miscellaneous Registers

Table 260: Register map crg2632\_preg\_aon\_00

Address	Register	Description
0x50000300	<a href="#">HWR_CTRL_REG</a>	Hardware Reset control register
0x50000304	<a href="#">RESET_STAT_REG</a>	Reset status register
0x50000308	<a href="#">RAM_LPMX_REG</a>	
0x5000030C	<a href="#">PAD_LATCH_REG</a>	Control the state retention of the GPIO ports
0x50000310	<a href="#">HIBERN_CTRL_REG</a>	Hibernation control register
0x50000320	<a href="#">POWER_AON_CTRL_REG</a>	
0x50000324	<a href="#">GP_DATA_REG</a>	

Table 261: [HWR\\_CTRL\\_REG](#) (0x50000300)

Bit	Mode	Symbol	Description	Reset
0	R/W	DISABLE_HWR	Disables the RST functionality on P00	0x0

Table 262: [RESET\\_STAT\\_REG](#) (0x50000304)

Bit	Mode	Symbol	Description	Reset
3	R/W	WDOGRESET_STAT	Indicates that a Watchdog has happened. This bit is also set with a PowerOn Reset	0x1
2	R/W	SWRESET_STAT	Indicates that a SW Reset has been requested. The SW reset is requested by SYS_CTRL_REG[SW_RESET] or SCB->AIRCR inside the Cortex. This bit is also set with a PowerOn Reset	0x1
1	R/W	HWRESET_STAT	Indicates that a HW Reset has happened This bit is also set with a PowerOn Reset	0x1
0	R/W	PORESET_STAT	Indicates that a PowerOn Reset has happened	0x1

Table 263: [RAM\\_LPMX\\_REG](#) (0x50000308)

Bit	Mode	Symbol	Description	Reset
2:0	R/W	RAMx_LPMX	RAM[3:1] Transparent Light Sleep (TLS) Core Enable for System RAMs. Assert low to enable the TLS core feature, which will result in lower leakage current.  In case VDD is below 0.81V, it is necessary to hold this pin high to maintain data retention.	0x7

Table 264: PAD\_LATCH\_REG (0x5000030C)

Bit	Mode	Symbol	Description	Reset
0	R/W	PAD_LATCH_EN	Controls the state retention of the pads. 0: latches are closed, pads retain their state. 1: latches are open, new control values have immediate effect	0x1

Table 265: HIBERN\_CTRL\_REG (0x50000310)

Bit	Mode	Symbol	Description	Reset
6:2	R/W	HIBERN_WKUP_M ASK	Selects which pin to wakeup from	0x0
1	R/W	HIBERN_WKUP_P OLARITY	Selects the polarity of the wakeup source. The polarity must be chosen such that the ANA_STATUS_REG[CLKLESS_WAKEUP_STAT] is '1'. Any change on the selected GPIOs will make the CLKLESS_WAKEUP_STAT go to '0', and wakeup the system from hibernation.	0x0
0	R/W	HIBERNATION_EN ABLE	Enables the hibernation mode when sleeping 0: deep sleep mode, PD_SLP remains on 1: hibernation mode, PD_SLP goes off. REMAP_ADR0 needs to be set to the correct source to boot from before going to sleep.	0x0

Table 266: POWER\_AON\_CTRL\_REG (0x50000320)

Bit	Mode	Symbol	Description	Reset
14	-	-		0x0
13:10	R/W	LDO_RET_TRIM	VDD clamp level setting for hibernation mode	0x0
9	R/W	CMP_VCONT_SLP _DISABLE	Disable vcont comparator in SLP	0x0
8:7	R/W	BOOST_MODE_FO RCE	0x: automatic selection of boost mode 11: force boost mode 10: force buck mode	0x0
6	R/W	CHARGE_VBAT_DI SABLE	Do not charge vbat high in boost mode	0x0
5	-	-		0x0
4	-	-		0x0
3	R/W	POR_VBAT_HIGH_ RST_MASK	Mask rst from por_vbat_high	0x1
2	R/W	POR_VBAT_LOW_ RST_MASK	Mask rst from por_vbat_low	0x0
1:0	R/W	VBAT_HL_CONNE CT_RES_CTRL	00: OFF 01: Forced ON 10: Active: automatic control, Sleep: forced ON 11: Automatic control	0x0

Table 267: GP\_DATA\_REG (0x50000324)

Bit	Mode	Symbol	Description	Reset
7	R/W	P03_P04_FILT_DIS	0: RC filtered input enabled for P0_3 and P0_4 (e.g. when used for wakeup) 1: RC filtered input disabled for P0_3 and P0_4 (e.g. when used for external clk or XTAL32k)	0x0
6	R/W	FORCE_RCX_VDD	0: RCX bias supply open (see FORCE_RCX_VREF) 1: RCX bias supply connected to VDD (use for sleep)	0x0
5	R/W	FORCE_RCX_VREF	0: RCX bias supply connected to clamp and VDD via 400k resistor (old situation) 1: RCX bias supply connected to vref_0v75_0 (use for calibration)	0x0
4	-	-		0x0
3:0	R/W	SW_GP_DATA		0x0

**31.11 OTP Controller Registers**
**Table 268: Register map OTPC**

Address	Register	Description
0x07F40000	OTPC_MODE_REG	Mode register
0x07F40004	OTPC_STAT_REG	Status register
0x07F40008	OTPC_PADDR_REG	The address of the word that will be programmed, when the PROG mode is used.
0x07F4000C	OTPC_PWORD_REG	The 32-bit word that will be programmed, when the PROG mode is used.
0x07F40010	OTPC_TIM1_REG	Various timing parameters of the OTP cell.
0x07F40014	OTPC_TIM2_REG	Various timing parameters of the OTP cell.
0x07F40018	OTPC_AHBADR_REG	AHB master start address
0x07F4001C	OTPC_CELADR_REG	OTP cell start address
0x07F40020	OTPC_NWORDS_REG	Number of words

**Table 269: OTPC\_MODE\_REG (0x07F40000)**

Bit	Mode	Symbol	Description	Reset
31:8	-	-		0x0
7:6	R/W	OTPC_MODE_PRG_SEL	<p>Defines the part of the OTP cell that is programmed by the controller during the PROG mode, for each program request that is applied.</p> <p>0x0 : Both normal and redundancy arrays are programmed. This is the normal way of programming.</p> <p>0x1 : Only the normal array is programmed.</p> <p>0x2 : Only the redundancy array is programmed.</p> <p>0x3 : Reserved</p> <p>The value of this configuration field can be modified only when the controller is in an inactive mode (DSTBY or STBY). The setting will take effect when will be enabled again the PROG mode.</p>	0x0
5	R/W	OTPC_MODE_HT_MARG_EN	<p>Defines the temperature condition under which is performed a margin read. It affects only the initial margin read (RINI mode) and the programming verification margin read (PVFY).</p> <p>0 : Regular temperature condition (less than 85°C)</p> <p>1 : High temperature condition (85°C or more)</p> <p>The value of this configuration field can be modified only when the controller is in an inactive mode (DSTBY or STBY). The selection will take effect at the next PVFY or RINI mode that will be enabled. The READ mode is not affected by the setting of this configuration bit.</p>	0x0
4	R/W	OTPC_MODE_USE_TST_ROW	Selects the memory area of the OTP cell that will be used.	0x0

Bit	Mode	Symbol	Description	Reset
			0 - Uses the main memory area of the OTP cell 1 - Uses the test row of the OTP cell The value of this configuration field can be modified only when the controller is in an inactive mode (DSTBY or STBY). The selection will take effect at the next programming or reading mode that will be enabled.	
3	-	-		0x0
2:0	R/W	OTPC_MODE_MODE	Defines the mode of operation of the OTPC controller. The encoding of the modes is as follows: 0x0: DSTBY. The OTP memory is in deep standby mode (power supply ON and internal LDO OFF). 0x1: STBY. The OTP memory is powered (power supply ON and internal LDO ON, but is not selected). 0x2: READ. The OTP memory is in the normal read mode. 0x3: PROG. The OTP memory is in programming mode. 0x4: PVFY. The OTP memory is in programming verification mode (margin read after programming). 0x5: RINI. The OTP memory is in initial read mode (initial margin read). 0x6: AREAD. Copying of data from the OTP memory to a system RAM by using the internal DMA. See also the registers OTPC_AHBADR_REG, OTPC_CELADR_REG and OTPC_NWORDS_REG.  Whenever the OTPC_MODE_REG[MODE] is changing, the status bit OTPC_STAT_REG[OTPC_STAT_MRDY] gets the value zero. The new mode will be ready for use when the OTPC_STAT_MRDY become again 1. During the mode transition the OTPC_MODE_REG[MODE] become read only. Do not try to use or change any function of the controller until the OTPC_STAT_MRDY bit to become equal to 1.  The data transferring that is performed by using the AREAD mode is completed when OTPC_STAT_MRDY becomes again 1. The mode change automatically to DSTBY with the completion of the transfer.	0x0

Table 270: OTPC\_STAT\_REG (0x07F40004)

Bit	Mode	Symbol	Description	Reset
31:3	-	-		0x0
2	R	OTPC_STAT_MRDY	Indicates the progress of the transition from a mode of operation to a new mode of operation.	0x1



Bit	Mode	Symbol	Description	Reset
			<p>0 : There is a transition in progress in a new mode of operation . Wait until the transition to be completed.</p> <p>1 : The transition to the new mode of operation has been completed. The function that has been enabled by the new mode can be used. A new mode can be applied.</p> <p>This status bit gets the value zero every time where the OTPC_MODE_REG[MODE] is changing. Do not try to use or change any function of the controller until this status bit to become equal to 1.</p>	
1	R	OTPC_STAT_PBUF_EMPTY	<p>Indicates the status of the programming buffer (PBUF).</p> <p>0 : The PBUF contains the address and the data of a programming request. The OTPC_PADDR_REG and the OTPC_PWORD_REG should not be written as long as this status bit is zero.</p> <p>1 : The PBUF is empty and a new programming request can be registered in the PBUF by using the OTPC_PADDR_REG and the OTPC_PWORD_REG registers.</p> <p>This status bit gets the value zero every time where a programming is triggered by the OTPC_PADDR_REG (only if the PROG mode is active).</p>	0x1
0	R	OTPC_STAT_PREADY	<p>Indicates the state of the programming process.</p> <p>0: The controller is busy. A programming is in progress.</p> <p>1: The logic which performs programming is idle.</p>	0x1

Table 271: OTPC\_PADDR\_REG (0x07F40008)

Bit	Mode	Symbol	Description	Reset
31:13	-	-		0x0
12:0	R/W	OTPC_PADDR	<p>The OTPC_PADDR_REG and the OTPC_PWORD_REG consist the PBUF buffer that keeps the information that will be programmed in the OTP, by using the PROG mode. The PBUF holds the address (OTPC_PADDR_REG) and the data (OTPC_PWORD_REG) of each of the programming requests that are applied in the OTP memory.</p> <p>The OTPC_PADDR_REG refers to a word address. The OTPC_PADDR_REG has to be written after the OTP_PWORD_REG and only if the OTPC_STAT_REG[OTPC_STAT_PBUF_EMPTY] =1. The register is read only for as long the PBUF is not empty (OTPC_STAT_REG[OTPC_STAT_PBUF_EMPTY] =0). A writing to the OTPC_PADDR_REG triggers the controller to start the programming procedure (only if the PROG mode is active).</p>	0x0

Table 272: OTPC\_PWORD\_REG (0x07F4000C)

Bit	Mode	Symbol	Description	Reset
31:0	R/W	OTPC_PWORD	<p>The OTPC_PADDR_REG and the OTPC_PWORD_REG consist the PBUF buffer that keeps the information that will be programmed in the OTP memory, by using the PROG mode. The PBUF holds the address (OTPC_PADDR_REG) and the data (OTPC_PWORD_REG) of each of the programming requests that are applied in the OTP memory.</p> <p>The OTP_PWORD_REG must be written before the OTPC_PADDR_REG and only if OTPC_STAT_REG[OTPC_STAT_PBUF_EMPTY] = 1. The register is read only for as long the PBUF is not empty (OTPC_STAT_REG[OTPC_STAT_PBUF_EMPTY]=0).</p>	0x0

Table 273: OTPC\_TIM1\_REG (0x07F40010)

Bit	Mode	Symbol	Description	Reset
31	-	-		0x0
30:24	R/W	OTPC_TIM1_US_T_CSP	<p>The number of microseconds (minus one) that are required after the selection of the OTP memory, until to be ready for programming. It must be :</p> <ul style="list-style-type: none"> <li>- at least 10us</li> <li>- no more than 100us</li> </ul>	0x9
23:20	R/W	OTPC_TIM1_US_T_CS	<p>The number of microseconds (minus one) that are required after the selection of the OTP memory, until to be ready for any kind of read. It must be at least 10us.</p>	0x9
19:16	R/W	OTPC_TIM1_US_T_PL	<p>The number of microseconds (minus one) that are required until to be enabled the LDO of the OTP. It must be at least 10us.</p>	0x9
15	-	-		0x0
14:12	R/W	OTPC_TIM1_CC_T_RD	<p>The number of hclk_c clock periods (minus one) that give a time interval at least higher than 60ns. This timing parameter refers to the access time of the OTP memory.</p>	0x0
11:10	-	-		0x0
9:8	R/W	OTPC_TIM1_CC_T_20NS	<p>The number of hclk_c clock periods (minus one) that give a time interval that is at least higher than 20 ns.</p>	0x0
7	-	-		0x0
6:0	R/W	OTPC_TIM1_CC_T_1US	<p>The number of hclk_c clock periods (minus one) that give a time interval equal to 1us. This setting affects all the timing parameters that refer to microseconds, due to that defines the correspondence of a microsecond to a number of hclk_c clock cycles.</p>	0xF

Table 274: **OTPC\_TIM2\_REG (0x07F40014)**

Bit	Mode	Symbol	Description	Reset
31	R/W	OTPC_TIM2_US_A DD_CC_EN	Adds an additional hclk_c clock cycle at all the time intervals that count in microseconds. 0 : The extra hclk_c clock cycle is not applied 1 : The extra hclk_c clock cycle is applied	0x1
30:29	R/W	OTPC_TIM2_US_T _SAS	The number of microseconds (minus one) that are required after the exit from the deep sleep standby mode and before to become ready to enter in an active mode (reading or programming). It must be at least 2us.	0x1
28:24	R/W	OTPC_TIM2_US_T _PPH	The number of microseconds (minus one) that are required after the last programming pulse and before to be disabled the programming mode in the OTP memory. It must be: - at least 5us - no more than 20us	0x4
23:21	R/W	OTPC_TIM2_US_T _VDS	The number of microseconds (minus one) that are required after the enabling of the power supply of the OTP memory and before to become ready for the enabling of the internal LDO. It must be at least 1us.	0x0
20:16	R/W	OTPC_TIM2_US_T _PPS	The number of microseconds (minus one) that are required after the enabling of the programming in the OTP memory and before to be applied the first programming pulse. It must be : - at least 5us - no more than 20us	0x4
15	-	-		0x0
14:8	R/W	OTPC_TIM2_US_T _PPR	The number of microseconds (minus one) for recovery after a programming sequence. It must be : - at least 5us - no more than 100us	0x4
7:5	R/W	OTPC_TIM2_US_T _PWI	The number of microseconds (minus one) between two consecutive programming pulses. It must be : - at least 1us - no more than 5us	0x0
4:0	R/W	OTPC_TIM2_US_T _PW	The number of microseconds (minus one) that lasts the programming of each bit. It must be : - at least 10us - no more than 20us	0x9

Table 275: **OTPC\_AHBADR\_REG (0x07F40018)**

Bit	Mode	Symbol	Description	Reset
31:16	-	-		0x0

Bit	Mode	Symbol	Description	Reset
15:2	R/W	OTPC_AHBADR	It is the AHB address used by the AHB master interface of the controller (the bits [15:2]). The bits [1:0] of the address are considered always as equal to zero. The value of the register remains unchanged, by the internal logic of the controller.	0x0
1:0	-	-		0x0

Table 276: **OTPC\_CELADR\_REG (0x07F4001C)**

Bit	Mode	Symbol	Description	Reset
31:13	-	-		0x0
12:0	R/W	OTPC_CELADR	Defines a word address inside the OTP cell that will be used during the AREAD mode and the OTP mirroring.	0x0

Table 277: **OTPC\_NWORDS\_REG (0x07F40020)**

Bit	Mode	Symbol	Description	Reset
31:13	-	-		0x0
12:0	R/W	OTPC_NWORDS	The number of words (minus one) that will be copied by the AREAD mode. During mirroring, this register reflects the amount of data that will be copied.	0x0

## 31.12 Quadrature Decoder Registers

Table 278: Register map QDEC

Address	Register	Description
0x50000200	QDEC_CTRL_REG	Quad Decoder control register
0x50000202	QDEC_XCNT_REG	Counter value of the X Axis
0x50000204	QDEC_YCNT_REG	Counter value of the Y Axis
0x50000206	QDEC_CLOCKDIV_REG	Clock divider register
0x50000208	QDEC_CTRL2_REG	Quad Decoder port selection register
0x5000020A	QDEC_ZCNT_REG	Counter value of the Z Axis
0x5000020C	QDEC_EVENT_CNT_REG	Event counter register

Table 279: QDEC\_CTRL\_REG (0x50000200)

Bit	Mode	Symbol	Description	Reset
10:3	R/W	QDEC_IRQ_THRES	Defines the number of events on either counter (X or Y or Z) that need to be reached before an interrupt is generated. Events are equal to QDEC_IRQ_THRES+1.	0x2
2	R/W	QDEC_IRQ_STATUS	1 = Interrupt is occurred. 0 = No interrupt pending Write 1 will clear the pending interrupt	0x0
1	R0/WC	QDEC_EVENT_CNT_CLR	Writing 1 QDEC_EVENT_CNT_REG is cleared	0x0
0	R/W	QDEC_IRQ_ENABLE	0 = interrupt is masked 1 = interrupt is enabled	0x1

Table 280: QDEC\_XCNT\_REG (0x50000202)

Bit	Mode	Symbol	Description	Reset
15:0	R	QDEC_X_CNT	Contains a signed value of the events. Zero when channel is disabled	0x0

Table 281: QDEC\_YCNT\_REG (0x50000204)

Bit	Mode	Symbol	Description	Reset
15:0	R	QDEC_Y_CNT	Contains a signed value of the events. Zero when channel is disabled	0x0

Table 282: QDEC\_CLOCKDIV\_REG (0x50000206)

Bit	Mode	Symbol	Description	Reset
10	R/W	QDEC_PRESCALE R_EN	0 = no prescaler enabled 1 = in sleep and active mode, quadrature clock is divided by 2	0x0
9:0	R/W	QDEC_CLOCKDIV	Contains the number of the input clock cycles minus one, that are required to generate one logic clock cycle.  Clock divider is bypassed when system runs at LP_CLK	0x3E7

Table 283: QDEC\_CTRL2\_REG (0x50000208)

Bit	Mode	Symbol	Description	Reset
11	R/W	QDEC_CHZ_EVEN T_MODE	0 = Normal quadrature counting 1 = Counts rising and falling edge of both ports (if both ports change at the same time, counter increases by 1)	0x1
10	R/W	QDEC_CHY_EVEN T_MODE	0 = Normal quadrature counting 1 = Counts rising and falling edge of both ports (if both ports change at the same time, counter increases by 1)	0x1
9	R/W	QDEC_CHX_EVEN T_MODE	0 = Normal quadrature counting 1 = Counts rising and falling edge of both ports (if both ports change at the same time, counter increases by 1)	0x1
8:6	R/W	QDEC_CHZ_PORT _SEL	Defines which GPIOs are mapped on Channel Z 0: none 1: P0[2] -> CHZ_A, P0[5] -> CHZ_B 2: P0[1] -> CHZ_A, P0[4] -> CHZ_B 3: P0[3] -> CHZ_A, P0[10] -> CHZ_B 4: P0[6] -> CHZ_A, P0[7] -> CHZ_B 5: P0[8] -> CHZ_A, P0[9] -> CHZ_B 6: P0[0] -> CHZ_A, P0[11] -> CHZ_B 7: none	3
5:3	R/W	QDEC_CHY_PORT _SEL	Defines which GPIOs are mapped on Channel Y 0: none 1: P0[2] -> CHY_A, P0[5] -> CHY_B 2: P0[1] -> CHY_A, P0[4] -> CHY_B 3: P0[3] -> CHY_A, P0[10] -> CHY_B 4: P0[6] -> CHY_A, P0[7] -> CHY_B 5: P0[8] -> CHY_A, P0[9] -> CHY_B 6: P0[0] -> CHY_A, P0[11] -> CHY_B 7: none	2
2:0	R/W	QDEC_CHX_PORT _SEL	Defines which GPIOs are mapped on Channel X 0: none 1: P0[2] -> CHX_A, P0[5] -> CHX_B 2: P0[1] -> CHX_A, P0[4] -> CHX_B 3: P0[3] -> CHX_A, P0[10] -> CHX_B	1

Bit	Mode	Symbol	Description	Reset
			4: P0[6] -> CHX_A, P0[7] -> CHX_B 5: P0[8] -> CHX_A, P0[9] -> CHX_B 6: P0[0] -> CHX_A, P0[11] -> CHX_B 7: none	

Table 284: QDEC\_ZCNT\_REG (0x5000020A)

Bit	Mode	Symbol	Description	Reset
15:0	R	QDEC_Z_CNT	Contains a signed value of the events. Zero when channel is disabled	0

Table 285: QDEC\_EVENT\_CNT\_REG (0x5000020C)

Bit	Mode	Symbol	Description	Reset
7:0	R	QDEC_EVENT_CN T	Gives the number of events at all channels.	0x0

## 31.13 Real Time Clock Registers

Table 286: Register map rtc2632\_00

Address	Register	Description
0x50004100	RTC_CONTROL_REG	RTC Control Register
0x50004104	RTC_HOUR_MODE_REG	RTC Hour Mode Register
0x50004108	RTC_TIME_REG	RTC Time Register
0x5000410C	RTC_CALENDAR_REG	RTC Calendar Register
0x50004110	RTC_TIME_ALARM_REG	RTC Time Alarm Register
0x50004114	RTC_CALENDAR_ALARM_REG	RTC Calendar Alarm Register
0x50004118	RTC_ALARM_ENABLE_REG	RTC Alarm Enable Register
0x5000411C	RTC_EVENT_FLAGS_REG	RTC Event Flags Register
0x50004120	RTC_INTERRUPT_ENABLE_REG	RTC Interrupt Enable Register
0x50004124	RTC_INTERRUPT_DISABLE_REG	RTC Interrupt Disable Register
0x50004128	RTC_INTERRUPT_MASK_REG	RTC Interrupt Mask Register
0x5000412C	RTC_STATUS_REG	RTC Status Register
0x50004130	RTC_KEEP_RTC_REG	RTC Keep RTC Register

Table 287: RTC\_CONTROL\_REG (0x50004100)

Bit	Mode	Symbol	Description	Reset
1	R/W	RTC_CAL_DISABLE	When this field is set high the RTC stops incrementing the calendar value.	0x1
0	R/W	RTC_TIME_DISABLE	When this field is set high the RTC stops incrementing the time value.	0x1

Table 288: RTC\_HOUR\_MODE\_REG (0x50004104)

Bit	Mode	Symbol	Description	Reset
0	R/W	RTC_HMS	When this field is set high the RTC operates in 12 hour clock mode; otherwise, times are in 24 hour clock format.	0x0



Table 289: RTC\_TIME\_REG (0x50004108)

Bit	Mode	Symbol	Description	Reset
31	R/W	RTC_TIME_CH	The value in this register has altered since last read. Read and clear.	0x0
30	R/W	RTC_TIME_PM	In 12 hour clock mode, indicates PM when set.	0x0
29:28	R/W	RTC_TIME_HR_T	Hours tens. Represented in BCD digit (0-2).	0x0
27:24	R/W	RTC_TIME_HR_U	Hours units. Represented in BCD digit (0-9).	0x0
23	-	-		0x0
22:20	R/W	RTC_TIME_M_T	Minutes tens. Represented in BCD digit (0-5).	0x0
19:16	R/W	RTC_TIME_M_U	Minutes units. Represented in BCD digit (0-9).	0x0
15	-	-		0x0
14:12	R/W	RTC_TIME_S_T	Seconds tens. Represented in BCD digit (0-9).	0x0
11:8	R/W	RTC_TIME_S_U	Seconds units. Represented in BCD digit (0-9).	0x0
7:4	R/W	RTC_TIME_H_T	Hundredths of a second tens. Represented in BCD digit (0-9).	0x0
3:0	R/W	RTC_TIME_H_U	Hundredths of a second units. Represented in BCD digit (0-9).	0x0

Table 290: RTC\_CALENDAR\_REG (0x5000410C)

Bit	Mode	Symbol	Description	Reset
31	R/W	RTC_CAL_CH	The value in this register has altered since last read. Read and clear	0x0
30	-	-		0x0
29:28	R/W	RTC_CAL_C_T	Century tens. Represented in BCD digit (1-2).	0x2
27:24	R/W	RTC_CAL_C_U	Century units. Represented in BCD digit (0-9).	0x0
23:20	R/W	RTC_CAL_Y_T	Year tens. Represented in BCD digit (0-9).	0x0
19:16	R/W	RTC_CAL_Y_U	Year units. Represented in BCD digit (0-9).	0x0
15:14	-	-		0x0
13:12	R/W	RTC_CAL_D_T	Date tens. Represented in BCD digit (0-3).	0x0
11:8	R/W	RTC_CAL_D_U	Date units. Represented in BCD digit (0-9).	0x1
7	R/W	RTC_CAL_M_T	Month tens. Represented in BCD digit (0-1).	0x0
6:3	R/W	RTC_CAL_M_U	Month units. Represented in BCD digit (0-9).	0x1
2:0	R/W	RTC_DAY	Day of the week (arbitrary) units. Represented in BCD digit (0-7).	0x7

Table 291: RTC\_TIME\_ALARM\_REG (0x50004110)

Bit	Mode	Symbol	Description	Reset
31	-	-		0x0
30	R/W	RTC_TIME_PM	In 12 hour clock mode, indicates PM when set.	0x0
29:28	R/W	RTC_TIME_HR_T	Hours tens. Represented in BCD digit (0-2).	0x0

Bit	Mode	Symbol	Description	Reset
27:24	R/W	RTC_TIME_HR_U	Hours units. Represented in BCD digit (0-9).	0x0
23	-	-		0x0
22:20	R/W	RTC_TIME_M_T	Minutes tens. Represented in BCD digit (0-5).	0x0
19:16	R/W	RTC_TIME_M_U	Minutes units. Represented in BCD digit (0-9).	0x0
15	-	-		0x0
14:12	R/W	RTC_TIME_S_T	Seconds tens. Represented in BCD digit (0-9).	0x0
11:8	R/W	RTC_TIME_S_U	Seconds units. Represented in BCD digit (0-9).	0x0
7:4	R/W	RTC_TIME_H_T	Hundredths of a second tens. Represented in BCD digit (0-9).	0x0
3:0	R/W	RTC_TIME_H_U	Hundredths of a second units. Represented in BCD digit (0-9).	0x0

Table 292: RTC\_CALENDAR\_ALARM\_REG (0x50004114)

Bit	Mode	Symbol	Description	Reset
31:14	R/W	-		0x0
13:12	R/W	RTC_CAL_D_T	Date tens. Represented in BCD digit (0-3).	0x0
11:8	R/W	RTC_CAL_D_U	Date units. Represented in BCD digit (0-9).	0x0
7	R/W	RTC_CAL_M_T	Month tens. Represented in BCD digit (0-1).	0x0
6:3	R/W	RTC_CAL_M_U	Month units. Represented in BCD digit (0-9).	0x0
2:0	-	-		0x0

Table 293: RTC\_ALARM\_ENABLE\_REG (0x50004118)

Bit	Mode	Symbol	Description	Reset
5	R/W	RTC_ALARM_MNT_H_EN	Alarm on month enable. Enable to trigger alarm when data specified in Calendar Alarm Register (M_T and M_U) has been reached.	0x0
4	R/W	RTC_ALARM_DATE_EN	Alarm on date enable. Enable to trigger alarm when data specified in Calendar Alarm Register (D_T and D_U) has been reached.	0x0
3	R/W	RTC_ALARM_HOUR_EN	Alarm on hour enable. Enable to trigger alarm when data specified in Time Alarm Register (PM, HR_T and HR_U) has been reached.	0x0
2	R/W	RTC_ALARM_MIN_EN	Alarm on minute enable. Enable to trigger alarm when data specified in Time Alarm Register (M_T and M_U) has been reached.	0x0
1	R/W	RTC_ALARM_SEC_EN	Alarm on second enable. Enable to trigger alarm when data specified in Time Alarm Register (S_T and S_U) has been reached.	0x0
0	R/W	RTC_ALARM_HOS_EN	Alarm on hundredths of a second enable. Enable to trigger alarm when data specified in Time Alarm Register (H_T and H_U) has been reached.	0x0

Table 294: RTC\_EVENT\_FLAGS\_REG (0x5000411C)

Bit	Mode	Symbol	Description	Reset
6	R	RTC_EVENT_ALR M	Alarm event flag. Indicate that alarm event occurred since the last reset.	0x0
5	R	RTC_EVENT_MNT H	Month rolls over event flag. Indicate that month rolls over event occurred since the last reset.	0x0
4	R	RTC_EVENT_DATE	Date rolls over event flag. Indicate that date rolls over event occurred since the last reset.	0x0
3	R	RTC_EVENT_HOU R	Hour rolls over event flag. Indicate that hour rolls over event occurred since the last reset.	0x0
2	R	RTC_EVENT_MIN	Minute rolls over event flag. Indicate that minute rolls over event occurred since the last reset.	0x0
1	R	RTC_EVENT_SEC	Second rolls over event flag. Indicate that second rolls over event occurred since the last reset.	0x0
0	R	RTC_EVENT_HOS	Hundredths of a second event flag. Indicate that hundredths of a second rolls over event occurred since the last reset.	0x0

Table 295: RTC\_INTERRUPT\_ENABLE\_REG (0x50004120)

Bit	Mode	Symbol	Description	Reset
6	W	RTC_ALARM_INT_E N	Interrupt on alarm enable. Enable to issue the interrupt when alarm event occurred.	0x0
5	W	RTC_MNTH_INT_E N	Interrupt on month enable. Enable to issue the interrupt when month event occurred.	0x0
4	W	RTC_DATE_INT_E N	Interrupt on date enable. Enable to issue the interrupt when date event occurred.	0x0
3	W	RTC_HOUR_INT_E N	Interrupt on hour enable. Enable to issue the interrupt when hour event occurred.	0x0
2	W	RTC_MIN_INT_EN	Interrupt on minute enable. Enable to issue the interrupt when minute event occurred.	0x0
1	W	RTC_SEC_INT_EN	Interrupt on second enable. Enable to issue the interrupt when second event occurred.	0x0
0	W	RTC_HOS_INT_EN	Interrupt on hundredths of a second enable. Enable to issue the interrupt when hundredths of a second event occurred.	0x0

Table 296: RTC\_INTERRUPT\_DISABLE\_REG (0x50004124)

Bit	Mode	Symbol	Description	Reset
6	W	RTC_ALARM_INT_DI S	Interrupt on alarm disable. Disable to issue the interrupt when alarm event occurred.	0x0
5	W	RTC_MNTH_INT_DI S	Interrupt on month disable. Disable to issue the interrupt when month event occurred.	0x0
4	W	RTC_DATE_INT_DI S	Interrupt on date disable. Disable to issue the interrupt when date event occurred.	0x0
3	W	RTC_HOUR_INT_DI S	Interrupt on hour disable. Disable to issue the interrupt when hour event occurred.	0x0

Bit	Mode	Symbol	Description	Reset
2	W	RTC_MIN_INT_DIS	Interrupt on minute disable. Disable to issue the interrupt when minute event occurred.	0x0
1	W	RTC_SEC_INT_DIS	Interrupt on second disable. Disable to issue the interrupt when second event occurred.	0x0
0	W	RTC_HOS_INT_DIS	Interrupt on hundredths of a second disable. Disable to issue the interrupt when hundredths of a second event occurred.	0x0

Table 297: RTC\_INTERRUPT\_MASK\_REG (0x50004128)

Bit	Mode	Symbol	Description	Reset
6	R	RTC_ALARM_INT_MSK	Mask alarm interrupt. It can be cleared (set) by setting corresponding bit (ALRM) in Interrupt Enable Register (Interrupt Disable Register).	0x1
5	R	RTC_MNTH_INT_MSK	Mask month interrupt. It can be cleared (set) by setting corresponding bit (MNTH) in Interrupt Enable Register (Interrupt Disable Register).	0x1
4	R	RTC_DATE_INT_MSK	Mask date interrupt. It can be cleared (set) by setting corresponding bit (DATE) in Interrupt Enable Register (Interrupt Disable Register).	0x1
3	R	RTC_HOUR_INT_MSK	Mask hour interrupt. It can be cleared (set) by setting corresponding bit (HOUR) in Interrupt Enable Register (Interrupt Disable Register).	0x1
2	R	RTC_MIN_INT_MSK	Mask minute interrupt. It can be cleared (set) by setting corresponding bit (MIN) in Interrupt Enable Register (Interrupt Disable Register).	0x1
1	R	RTC_SEC_INT_MSK	Mask second interrupt. It can be cleared (set) by setting corresponding bit (SEC) in Interrupt Enable Register (Interrupt Disable Register).	0x1
0	R	RTC_HOS_INT_MSK	Mask hundredths of a second interrupt. It can be cleared (set) by setting corresponding bit (HOS) in Interrupt Enable Register (Interrupt Disable Register).	0x1

Table 298: RTC\_STATUS\_REG (0x5000412C)

Bit	Mode	Symbol	Description	Reset
3	R	RTC_VALID_CAL_ALM	Valid Calendar Alarm. If cleared then indicates that invalid entry occurred when writing to Calendar Alarm Register.	0x1
2	R	RTC_VALID_TIME_ALM	Valid Time Alarm. If cleared then indicates that invalid entry occurred when writing to Time Alarm Register.	0x1
1	R	RTC_VALID_CAL	Valid Calendar. If cleared then indicates that invalid entry occurred when writing to Calendar Register.	0x1
0	R	RTC_VALID_TIME	Valid Time. If cleared then indicates that invalid entry occurred when writing to Time Register.	0x1

Table 299: RTC\_KEEP\_RTC\_REG (0x50004130)

Bit	Mode	Symbol	Description	Reset
0	R/W	RTC_KEEP	Keep RTC. When high, the time and calendar registers and any other registers which directly affect or are affected by the time and calendar registers are NOT reset when software reset is applied. When low, the software reset will reset every register except the keep RTC and control registers.	0x1

## 31.14 SPI Interface Registers

Table 300: Register map SPI

Address	Register	Description
0x50001200	<a href="#">SPI_CTRL_REG</a>	Spi control register
0x50001204	<a href="#">SPI_CONFIG_REG</a>	Spi control register
0x50001208	<a href="#">SPI_CLOCK_REG</a>	Spi clock register
0x5000120C	<a href="#">SPI_FIFO_CONFIG_REG</a>	Spi fifo configuration register
0x50001210	<a href="#">SPI_IRQ_MASK_REG</a>	Spi interrupt mask register
0x50001214	<a href="#">SPI_STATUS_REG</a>	Spi status register
0x50001218	<a href="#">SPI_FIFO_STATUS_REG</a>	SPI RX/TX fifo status register
0x5000121C	<a href="#">SPI_FIFO_READ_REG</a>	Spi RX fifo read register
0x50001220	<a href="#">SPI_FIFO_WRITE_REG</a>	Spi TX fifo write register
0x50001224	<a href="#">SPI_CS_CONFIG_REG</a>	Spi cs configuration register
0x50001228	<a href="#">SPI_FIFO_HIGH_REG</a>	Spi TX/RX High 16bit word
0x5000122C	<a href="#">SPI_TXBUFFER_FORCE_L_REG</a>	SPI TX buffer force low value
0x50001230	<a href="#">SPI_TXBUFFER_FORCE_H_REG</a>	SPI TX buffer force high value

Table 301: [SPI\\_CTRL\\_REG \(0x50001200\)](#)

Bit	Mode	Symbol	Description	Reset
7	R/W	<a href="#">SPI_SWAP_BYTES</a>	0 = normal operation 1 = LSB and MSB are swapped in APB interface In case of 8bit spi interface, DMA/SPI can be configured in 16bit mode to off load the bus. Enabling <a href="#">SPI_SWAP_BYTES</a> bytes will read/write correctly	0x0
6	R/W	<a href="#">SPI_CAPTURE_AT_NEXT_EDGE</a>	0 = SPI captures data at correct clock edge 1 = SPI captures data at next clock edge. (only for Master mode and high clock)	0x0
5	R/W	<a href="#">SPI_FIFO_RESET</a>	0 = Fifo normal operation 1 = Fifo in reset state	0x0
4	R/W	<a href="#">SPI_DMA_RX_EN</a>	applicable only when <a href="#">SPI_RX_EN</a> =1 0 = No DMA request for RX 1 = DMA request when <a href="#">SPI_STATUS_RX_FULL</a> ='1'	0x0
3	R/W	<a href="#">SPI_DMA_TX_EN</a>	applicable only when <a href="#">SPI_TX_EN</a> =1	0x0

Bit	Mode	Symbol	Description	Reset
			0 = No DMA request for TX 1 = DMA request when SPI_STATUS_TX_EMPTY='1'	
2	R/W	SPI_RX_EN	0 = RX path is disabled 1 = RX path is enabled Note: if master clk async or spi mode=1 or spi mode=3 readonly is not supported	0x0
1	R/W	SPI_TX_EN	0 = TX path is disabled 1 = TX path is enabled	0x0
0	R/W	SPI_EN	0 = SPI module is disable 1 = SPI module is enable	0x0

Table 302: SPI\_CONFIG\_REG (0x50001204)

Bit	Mode	Symbol	Description	Reset
7	R/W	SPI_SLAVE_EN	0 = SPI module master mode 1 = SPI module slave mode	0x0
6:2	R/W	SPI_WORD_LENGTH	Define the spi word length = 1+ SPI_WORD_LENGTH (range 4 to 32)	0x0
1:0	R/W	SPI_MODE	Define the spi mode (CPOL, CPHA) 0 = new data on falling, capture on rising, clk low in idle state 1 = new data on rising, capture on falling, Clk low in idle state 2 = new data on rising, capture on falling, Clk high in idle state 3 = new data on falling, capture on rising Clk high in idle state	0x0

Table 303: SPI\_CLOCK\_REG (0x50001208)

Bit	Mode	Symbol	Description	Reset
7	R/W	SPI_MASTER_CLK_MODE	Should be always 1	0x0
6:0	R/W	SPI_CLK_DIV	Applicable only in master mode Defines the spi clock frequency in master only mode $SPI\_CLK = module\_clk / 2^{(SPI\_CLK\_DIV+1)}$ when SPI_CLK_DIV not 0x7F if SPI_CLK_DIV=0x7F then SPI_CLK=module_clk	0x0

Table 304: SPI\_FIFO\_CONFIG\_REG (0x5000120C)

Bit	Mode	Symbol	Description	Reset
7:4	R/W	SPI_RX_TL	Receive FIFO threshold level in bytes. Control the level of bytes in fifo that triggers the RX_FULL interrupt. IRQ is occurred when fifo level is more or equal to SPI_RX_TL+1. Fifo level is from 0 to 4	0x0
3:0	R/W	SPI_TX_TL	Transmit FIFO threshold level in bytes. Control the level of bytes in fifo that triggers the TX_EMPTY interrupt. IRQ is occurred when fifo level is less or equal to SPI_TX_TL. Fifo level is from 0 to 4	0x0

Table 305: SPI\_IRQ\_MASK\_REG (0x50001210)

Bit	Mode	Symbol	Description	Reset
1	R/W	SPI_IRQ_MASK_RX_FULL	0 = FIFO RX full irq is masked 1 = FIFO RX full irq is enabled	0x0
0	R/W	SPI_IRQ_MASK_TX_EMPTY	0 = FIFO TX empty irq is masked 1 = FIFO TX empty irq is enabled	0x0

Table 306: SPI\_STATUS\_REG (0x50001214)

Bit	Mode	Symbol	Description	Reset
1	R	SPI_STATUS_RX_FULL	Auto clear 0 = RX fifo level is less than SPI_RX_TL+1 1 = RX fifo level is more or equal to SPI_RX_TL+1	0x0
0	R	SPI_STATUS_TX_EMPTY	Auto clear 0 = TX fifo level is larger than SPI_TX_TL 1 = TX fifo level is less or equal to SPI_TX_TL	0x1

Table 307: SPI\_FIFO\_STATUS\_REG (0x50001218)

Bit	Mode	Symbol	Description	Reset
15	R	SPI_TRANSACTION_ACTIVE	In master mode 0 = spi transaction is inactive 1 = spi transaction is active	0x0
14	R	SPI_RX_FIFO_OVERFLOW	When 1, receive data is not written to fifo because fifo was full and interrupt is generated. It clears with SPI_CTRL_REG.SPI_FIFO_RESET	0x0
13	R	SPI_STATUS_TX_FULL	0 = TX fifo is not full 1 = TX fifo is full	0x0



Bit	Mode	Symbol	Description	Reset
12	R	SPI_STATUS_RX_EMPTY	0 = RX fifo is not empty 1 = RX fifo is empty	0x1
11:6	R	SPI_TX_FIFO_LEVEL	Gives the number of bytes in TX fifo	0x0
5:0	R	SPI_RX_FIFO_LEVEL	Gives the number of bytes in RX fifo	0x0

Table 308: SPI\_FIFO\_READ\_REG (0x5000121C)

Bit	Mode	Symbol	Description	Reset
15:0	R	SPI_FIFO_READ	Read from RX fifo. Read access is permit only if SPI_STATUS_RX_EMPTY=0. Returns the 16 LSb	0x0

Table 309: SPI\_FIFO\_WRITE\_REG (0x50001220)

Bit	Mode	Symbol	Description	Reset
15:0	R0/W	SPI_FIFO_WRITE	Write to TX fifo. Write access is permit only if SPI_STATUS_TX_FULL is 0	0x0

Table 310: SPI\_CS\_CONFIG\_REG (0x50001224)

Bit	Mode	Symbol	Description	Reset
2:0	R/W	SPI_CS_SELECT	Control the cs output in master mode 0 = none slave device selected 1 = selected slave device connected to GPIO with FUNC_MODE=SPI_CS0 2 = selected slave device connected to GPIO with FUNC_MODE=SPI_CS1 4 = selected slave device connected to GPIO with FUNC_MODE=GPIO	0x0

Table 311: SPI\_FIFO\_HIGH\_REG (0x50001228)

Bit	Mode	Symbol	Description	Reset
15:0	R/W	SPI_FIFO_HIGH	RX/TX fifo data. 16 MSb when spi word is larger than 16bits This register has to be written before the SPI_FIFO_WRITE_REG This register has to be read after the SPI_FIFO_READ_REG	0x0

**Table 312: SPI\_TXBUFFER\_FORCE\_L\_REG (0x5000122C)**

Bit	Mode	Symbol	Description	Reset
15:0	W	SPI_TXBUFFER_FORCE_L	Write directly the tx buffer (2 LSB). It must to be used only in slave mode	0x0

**Table 313: SPI\_TXBUFFER\_FORCE\_H\_REG (0x50001230)**

Bit	Mode	Symbol	Description	Reset
15:0	W	SPI_TXBUFFER_FORCE_H	Write directly the tx buffer (2 MSB). It must to be used only in slave mode. This register has to be written before the SPI_FIFO_WRITE_REG	0x0

## 31.15 Timer and Triple PWM Registers

Table 314: Register map Timer+3PWM

Address	Register	Description
0x50003400	TIMER0_CTRL_REG	Timer0 control register
0x50003402	TIMER0_ON_REG	Timer0 on control register
0x50003404	TIMER0_RELOAD_M_REG	16 bits reload value for Timer0
0x50003406	TIMER0_RELOAD_N_REG	16 bits reload value for Timer0
0x50003408	TRIPLE_PWM_FREQUENCY	Frequency for PWM 2,3,4,5,6 and 7
0x5000340A	PWM2_START_CYCLE	Defines start Cycle for PWM2
0x5000340C	PWM3_START_CYCLE	Defines start Cycle for PWM3
0x5000340E	PWM4_START_CYCLE	Defines start Cycle for PWM4
0x50003410	PWM5_START_CYCLE	Defines start Cycle for PWM5
0x50003412	PWM6_START_CYCLE	Defines start Cycle for PWM6
0x50003414	PWM7_START_CYCLE	Defines start Cycle for PWM7
0x50003416	PWM2_END_CYCLE	Defines end Cycle for PWM2
0x50003418	PWM3_END_CYCLE	Defines end Cycle for PWM3
0x5000341A	PWM4_END_CYCLE	Defines end Cycle for PWM4
0x5000341C	PWM5_END_CYCLE	Defines end Cycle for PWM5
0x5000341E	PWM6_END_CYCLE	Defines end Cycle for PWM6
0x50003420	PWM7_END_CYCLE	Defines end Cycle for PWM7
0x50003422	TRIPLE_PWM_CTRL_REG	PWM 2,3,4,5,6,7 Control

Table 315: TIMER0\_CTRL\_REG (0x50003400)

Bit	Mode	Symbol	Description	Reset
15:4	-	-		0x0
3	R/W	PWM_MODE	0 = PWM signals are '1' during high time. 1 = PWM signals send out the (fast) clock divided by 2 during high time. So it will be in the range of 1 to 8 MHz.	0x0
2	R/W	TIM0_CLK_DIV	1 = Timer0 uses selected clock frequency as is. 0 = Timer0 uses selected clock frequency divided by 10. Note that this applies only to the ON-counter.	0x0

Bit	Mode	Symbol	Description	Reset
1	R/W	TIM0_CLK_SEL	1 = Timer0 uses 16, 8, 4 or 2 MHz (fast) clock frequency. 0 = Timer0 uses LP clock	0x0
0	R/W	TIM0_CTRL	0 = Timer0 is off and in reset state. 1 = Timer0 is running.	0x0

Table 316: **TIMER0\_ON\_REG (0x50003402)**

Bit	Mode	Symbol	Description	Reset
15:0	R/W	TIM0_ON	Timer0 On reload value: If read the actual ON-counter value is returned	0x0

Table 317: **TIMER0\_RELOAD\_M\_REG (0x50003404)**

Bit	Mode	Symbol	Description	Reset
15:0	R/W	TIM0_M	Timer0 'high' reload value If read the actual T0-counter value is returned	0x0

Table 318: **TIMER0\_RELOAD\_N\_REG (0x50003406)**

Bit	Mode	Symbol	Description	Reset
15:0	R/W	TIM0_N	Timer0 'low' reload value: If read the actual T0-counter value is returned	0x0

Table 319: **TRIPLE\_PWM\_FREQUENCY (0x50003408)**

Bit	Mode	Symbol	Description	Reset
13:0	R/W	PWM_FREQ	Defines the frequency of PWM 2,3,4,5,,6 and 7. pwm freq = module Frequency / (value+1) module frequency is the LP_CLK when TRIPLE_PWM_CLK_SEL=0 else is the sys_clk divided by TMR_DIV	0x0

Table 320: **PWM2\_START\_CYCLE (0x5000340A)**

Bit	Mode	Symbol	Description	Reset
13:0	R/W	START_CYCLE	Defines the cycle in which the PWM becomes high. if start_cycle is larger than freq or end_cycle is equal to start_cycle, pwm out is always 0	0x0

Table 321: PWM3\_START\_CYCLE (0x5000340C)

Bit	Mode	Symbol	Description	Reset
13:0	R/W	START_CYCLE	Defines the cycle in which the PWM becomes high. if start_cycle is larger than freq or end_cycle is equal to start_cycle, pwm out is always 0	0x0

Table 322: PWM4\_START\_CYCLE (0x5000340E)

Bit	Mode	Symbol	Description	Reset
13:0	R/W	START_CYCLE	Defines the cycle in which the PWM becomes high. if start_cycle is larger than freq or end_cycle is equal to start_cycle, pwm out is always 0	0x0

Table 323: PWM5\_START\_CYCLE (0x50003410)

Bit	Mode	Symbol	Description	Reset
13:0	R/W	START_CYCLE	Defines the cycle in which the PWM becomes high. if start_cycle is larger than freq or end_cycle is equal to start_cycle, pwm out is always 0	0x0

Table 324: PWM6\_START\_CYCLE (0x50003412)

Bit	Mode	Symbol	Description	Reset
13:0	R/W	START_CYCLE	Defines the cycle in which the PWM becomes high. if start_cycle is larger than freq or end_cycle is equal to start_cycle, pwm out is always 0	0x0

Table 325: PWM7\_START\_CYCLE (0x50003414)

Bit	Mode	Symbol	Description	Reset
13:0	R/W	START_CYCLE	Defines the cycle in which the PWM becomes high. if start_cycle is larger than freq or end_cycle is equal to start_cycle, pwm out is always 0	0x0

Table 326: PWM2\_END\_CYCLE (0x50003416)

Bit	Mode	Symbol	Description	Reset
13:0	R/W	END_CYCLE	Defines the cycle in which the PWM becomes low. If end_cycle is larger then freq and start_cycle is not larger then freq, output is always 1	0x0

Table 327: PWM3\_END\_CYCLE (0x50003418)

Bit	Mode	Symbol	Description	Reset
13:0	R/W	END_CYCLE	Defines the cycle in which the PWM becomes low. If end_cycle is larger than freq and start_cycle is not larger than freq, output is always 1	0x0

Table 328: PWM4\_END\_CYCLE (0x5000341A)

Bit	Mode	Symbol	Description	Reset
13:0	R/W	END_CYCLE	Defines the cycle in which the PWM becomes low. If end_cycle is larger than freq and start_cycle is not larger than freq, output is always 1	0x0

Table 329: PWM5\_END\_CYCLE (0x5000341C)

Bit	Mode	Symbol	Description	Reset
13:0	R/W	END_CYCLE	Defines the cycle in which the PWM becomes low. If end_cycle is larger than freq and start_cycle is not larger than freq, output is always 1	0x0

Table 330: PWM6\_END\_CYCLE (0x5000341E)

Bit	Mode	Symbol	Description	Reset
13:0	R/W	END_CYCLE	Defines the cycle in which the PWM becomes low. If end_cycle is larger than freq and start_cycle is not larger than freq, output is always 1	0x0

Table 331: PWM7\_END\_CYCLE (0x50003420)

Bit	Mode	Symbol	Description	Reset
13:0	R/W	END_CYCLE	Defines the cycle in which the PWM becomes low. If end_cycle is larger than freq and start_cycle is not larger than freq, output is always 1	0x0

Table 332: TRIPLE\_PWM\_CTRL\_REG (0x50003422)

Bit	Mode	Symbol	Description	Reset
3	R/W	TRIPLE_PWM_CLK_SEL	1 = Timer2 uses 16, 8, 4 or 2 MHz (fast) clock frequency. 0 = Timer2 uses LP clock	0x0
2	R/W	HW_PAUSE_EN	'1' = HW can pause PWM 2,3,4,5,6,7	0x1
1	R/W	SW_PAUSE_EN	'1' = PWM 2 3 4 5 6 7 are paused	0x0
0	R/W	TRIPLE_PWM_ENABLE	'1' = enable PWM 2 3 4 5 6 7	0x0



## 31.16 Timer1 Registers

Table 333: Register map Timer1

Address	Register	Description
0x50004000	TIMER1_CTRL_REG	Timer1 control register
0x50004004	TIMER1_CAPTURE_REG	Timer1 Capture control register
0x50004008	TIMER1_STATUS_REG	Timer1 counter value
0x5000400C	TIMER1_CAPCNT1_VALUE_REG	Timer1 value for event on GPIO1
0x50004010	TIMER1_CAPCNT2_VALUE_REG	Timer1 value for event on GPIO2
0x50004014	TIMER1_CLR_EVENT_REG	Clear event register

Table 334: TIMER1\_CTRL\_REG (0x50004000)

Bit	Mode	Symbol	Description	Reset
16	R/W	TIMER1_CLK_EN	0 = timer1 clock is disabled 1 = timer1 clock is enabled	0x0
15	R/W	TIMER1_USE_SYSTEM_CLK	0 = Timer1 use the clock LP clock 1 = Timer1 use the system clock	0x0
14	R/W	TIMER1_FREE_RUN_MODE_EN	Applicable when timer counts up 1 = timer1 goes to zero when it reaches the max value. 0 = timer1 goes to zero when it reaches the reload value.	0x0
13	R/W	TIMER1_IRQ_EN	0 = timer1 IRQ masked 1 = timer1 IRQ unmasked	0x0
12	R/W	TIMER1_COUNT_DOWN_EN	0 = timer1 counts up 1 = timer1 counts down	0x0
11	R/W	TIMER1_ENABLE	0 = Timer1 disabled 1 = Timer1 enabled	0x0
10:0	R/W	TIMER1_RELOAD	Reload or max value in timer mode. Actual delay is the register value plus synchronization time (3 clock cycles)	0x0

Table 335: TIMER1\_CAPTURE\_REG (0x50004004)

Bit	Mode	Symbol	Description	Reset
27	R/W	TIMER1_IN2_STAMP_TYPE	0 = On each event store the counter value 1 = On each event store the RTC time stamp	0x0
26:21	R/W	TIMER1_IN2_PERIOD_MAX	Gives the number of periods +1 of IN2, in which module counts	0x0



Bit	Mode	Symbol	Description	Reset
20	R/W	TIMER1_IN2_IRQ_EN	1 = Interrupt is generated when capture is occurred or was counted TIMER1_IN2_PERIOD_MAX 0 = Interrupt is masked	0x0
19	R/W	TIMER1_IN2_COUNT_EN	0 = Capture mode 1 = Count mode	0x0
18	R/W	TIMER1_IN2_EVENT_FALL_EN	0 = Rising edge event 1 = Falling edge event it should be written when TIMER1_GPIO2_CONF=0 to prevent false events	0x0
17:14	R/W	TIMER1_GPIO2_CONF	0,13,14,15 = IN2 is not used 1..12 = Defines the P0 pin (0..11) module will use as IN2	0x0
13	R/W	TIMER1_IN1_STAMP_TYPE	0 = On each event store the counter value 1 = On each event store the RTC time stamp	0x0
12:7	R/W	TIMER1_IN1_PERIOD_MAX	Gives the number of periods +1 of IN1, in which module counts	0x0
6	R/W	TIMER1_IN1_IRQ_EN	1 = Interrupt is generated when capture is occurred or was counted TIMER1_IN1_PERIOD_MAX 0 = Interrupt is masked	0x0
5	R/W	TIMER1_IN1_COUNT_EN	0 = Capture mode 1 = Count mode	0x0
4	R/W	TIMER1_IN1_EVENT_FALL_EN	0 = Rising edge event 1 = Falling edge event it should be written when TIMER1_GPIO1_CONF=0 to prevent false events	0x0
3:0	R/W	TIMER1_GPIO1_CONF	0,13,14,15 = IN1 is not used 1..12 = Defines the P0 pin (0..11) module will use as IN1	0x0

Table 336: **TIMER1\_STATUS\_REG (0x50004008)**

Bit	Mode	Symbol	Description	Reset
15	R	TIMER1_IN2_OVRFLOW	1 = New IN2 event occurred while Interrupt was pending. TIMER1_CAPCNT2_VALUE_REG gives the time stamp of the first event.	0x0
14	R	TIMER1_IN1_OVRFLOW	1 = New IN1 event occurred while Interrupt was pending. TIMER1_CAPCNT1_VALUE_REG gives the time stamp of the first event.	0x0
13	R	TIMER1_IN2_EVENT	1 = Pending Capture 2 interrupt. It has be clear writing 1 to TIMER1_CLR_IN2_EVENT	0x0
12	R	TIMER1_IN1_EVENT	1 = Pending Capture 1 interrupt. It has be clear writing 1 to TIMER1_CLR_IN1_EVENT	0x0
11	R	TIMER1_TIMER_EVENT	1 = Pending Timer interrupt. it has be clear writing 1' to TIMER1_CLR_TIMER_EVENT	0x0

Bit	Mode	Symbol	Description	Reset
10:0	R	TIMER1_TIMER_VALUE	Gives the current timer value	0x0

Table 337: **TIMER1\_CAPCNT1\_VALUE\_REG (0x5000400C)**

Bit	Mode	Symbol	Description	Reset
21:11	R	TIMER1_CAPCNT1_RTC_HIGH	In Counter mode : Not used In Capture mode: Gives the RTC time stamp (high part) when an IN1 event was occurred	0x0
10:0	R	TIMER1_CAPCNT1_VALUE	In Counter mode : Gives the number of timer clock cycles minus 1 which was measured during TIMER1_IN1_PERIOD_MAX periods of IN1 In Capture mode (TIMER1_IN1_STAMP_TYPE=0) : Gives the Counter value when an IN1 event was occurred In Capture mode (TIMER1_IN1_STAMP_TYPE=1) : Gives the RTC time stamp (low part) when an IN1 event was occurred	0x0

Table 338: **TIMER1\_CAPCNT2\_VALUE\_REG (0x50004010)**

Bit	Mode	Symbol	Description	Reset
21:11	R	TIMER1_CAPCNT2_RTC_HIGH	In Counter mode : Not used In Capture mode: Gives the RTC time stamp (high part) when an IN2 event was occurred	0x0
10:0	R	TIMER1_CAPCNT2_VALUE	In Counter mode : Gives the number of timer clock cycles minus 1 which was measured during TIMER1_IN2_PERIOD_MAX periods of IN2 In Capture mode (TIMER1_IN2_STAMP_TYPE=0) : Gives the Counter value when an IN2 event was occurred In Capture mode (TIMER1_IN2_STAMP_TYPE=1) : Gives the RTC time stamp (low part) when an IN2 event was occurred	0x0

Table 339: **TIMER1\_CLR\_EVENT\_REG (0x50004014)**

Bit	Mode	Symbol	Description	Reset
2	R0/WC	TIMER1_CLR_IN2_EVENT	Write 1 to clear the TIMER1_IN2_EVENT and TIMER1_IN2_OVRFLW	0x0
1	R0/WC	TIMER1_CLR_IN1_EVENT	Write 1 to clear the TIMER1_IN1_EVENT and TIMER1_IN1_OVRFLW	0x0
0	R0/WC	TIMER1_CLR_TIMER_EVENT	Write 1 to clear the TIMER1_TIMER_EVENT	0x0

## 31.17 UART Interface Registers

Table 340: Register map UART

Address	Register	Description
0x50001000	UART_RBR_THR_DL L_REG	Receive Buffer Register/Transmit Holding Register/Divisor Latch Low
0x50001004	UART_IER_DLH_REG	Interrupt Enable Register/Divisor Latch High
0x50001008	UART_IIR_FCR_REG	Interrupt Identification Register/FIFO Control Register
0x5000100C	UART_LCR_REG	Line Control Register
0x50001010	UART_MCR_REG	Modem Control Register
0x50001014	UART_LSR_REG	Line Status Register
0x50001018	UART_MSR_REG	Modem Status Register
0x5000101C	UART_SCR_REG	Scratchpad Register
0x50001030	UART_SRBR_STHR0 _REG	Shadow Receive/Transmit Buffer Register
0x50001034	UART_SRBR_STHR1 _REG	Shadow Receive/Transmit Buffer Register
0x50001038	UART_SRBR_STHR2 _REG	Shadow Receive/Transmit Buffer Register
0x5000103C	UART_SRBR_STHR3 _REG	Shadow Receive/Transmit Buffer Register
0x50001040	UART_SRBR_STHR4 _REG	Shadow Receive/Transmit Buffer Register
0x50001044	UART_SRBR_STHR5 _REG	Shadow Receive/Transmit Buffer Register
0x50001048	UART_SRBR_STHR6 _REG	Shadow Receive/Transmit Buffer Register
0x5000104C	UART_SRBR_STHR7 _REG	Shadow Receive/Transmit Buffer Register
0x50001050	UART_SRBR_STHR8 _REG	Shadow Receive/Transmit Buffer Register
0x50001054	UART_SRBR_STHR9 _REG	Shadow Receive/Transmit Buffer Register
0x50001058	UART_SRBR_STHR1 0_REG	Shadow Receive/Transmit Buffer Register
0x5000105C	UART_SRBR_STHR1 1_REG	Shadow Receive/Transmit Buffer Register
0x50001060	UART_SRBR_STHR1 2_REG	Shadow Receive/Transmit Buffer Register
0x50001064	UART_SRBR_STHR1 3_REG	Shadow Receive/Transmit Buffer Register
0x50001068	UART_SRBR_STHR1 4_REG	Shadow Receive/Transmit Buffer Register
0x5000106C	UART_SRBR_STHR1 5_REG	Shadow Receive/Transmit Buffer Register
0x50001070	UART_FAR_REG	FIFO Access Register

Address	Register	Description
0x5000107C	UART_USR_REG	UART Status Register
0x50001080	UART_TFL_REG	Transmit FIFO Level
0x50001084	UART_RFL_REG	Receive FIFO Level
0x50001088	UART_SRR_REG	Software Reset Register.
0x5000108C	UART_SRTS_REG	Shadow Request to Send
0x50001090	UART_SBCR_REG	Shadow Break Control Register
0x50001094	UART_SDMAM_REG	Shadow DMA Mode
0x50001098	UART_SFE_REG	Shadow FIFO Enable
0x5000109C	UART_SRT_REG	Shadow RCVR Trigger
0x500010A0	UART_STET_REG	Shadow TX Empty Trigger
0x500010A4	UART_HTX_REG	Halt TX
0x500010A8	UART_DMASA_REG	DMA Software Acknowledge
0x500010C0	UART_DLF_REG	Divisor Latch Fraction Register
0x500010F8	UART_UCV_REG	Component Version
0x500010FA	UART_UCV_HIGH_REG	Component Version
0x500010FC	UART_CTR_REG	Component Type Register
0x500010FE	UART_CTR_HIGH_REG	Component Type Register
0x50001100	UART2_RBR_THR_DLL_REG	Receive Buffer Register/Transmit Holding Register/Divisor Latch Low
0x50001104	UART2_IER_DLH_REG	Interrupt Enable Register/Divisor Latch High
0x50001108	UART2_IIR_FCR_REG	Interrupt Identification Register/FIFO Control Register
0x5000110C	UART2_LCR_REG	Line Control Register
0x50001110	UART2_MCR_REG	Modem Control Register
0x50001114	UART2_LSR_REG	Line Status Register
0x5000111C	UART2_SCR_REG	Scratchpad Register
0x50001130	UART2_SRBR_STHR0_REG	Shadow Receive/Transmit Buffer Register
0x50001134	UART2_SRBR_STHR1_REG	Shadow Receive/Transmit Buffer Register
0x50001138	UART2_SRBR_STHR2_REG	Shadow Receive/Transmit Buffer Register
0x5000113C	UART2_SRBR_STHR3_REG	Shadow Receive/Transmit Buffer Register
0x50001140	UART2_SRBR_STHR4_REG	Shadow Receive/Transmit Buffer Register
0x50001144	UART2_SRBR_STHR5_REG	Shadow Receive/Transmit Buffer Register
0x50001148	UART2_SRBR_STHR6_REG	Shadow Receive/Transmit Buffer Register

Address	Register	Description
0x5000114C	UART2_SRBR_STHR_7_REG	Shadow Receive/Transmit Buffer Register
0x50001150	UART2_SRBR_STHR_8_REG	Shadow Receive/Transmit Buffer Register
0x50001154	UART2_SRBR_STHR_9_REG	Shadow Receive/Transmit Buffer Register
0x50001158	UART2_SRBR_STHR_10_REG	Shadow Receive/Transmit Buffer Register
0x5000115C	UART2_SRBR_STHR_11_REG	Shadow Receive/Transmit Buffer Register
0x50001160	UART2_SRBR_STHR_12_REG	Shadow Receive/Transmit Buffer Register
0x50001164	UART2_SRBR_STHR_13_REG	Shadow Receive/Transmit Buffer Register
0x50001168	UART2_SRBR_STHR_14_REG	Shadow Receive/Transmit Buffer Register
0x5000116C	UART2_SRBR_STHR_15_REG	Shadow Receive/Transmit Buffer Register
0x50001170	UART2_FAR_REG	FIFO Access Register
0x5000117C	UART2_USR_REG	UART Status Register
0x50001180	UART2_TFL_REG	Transmit FIFO Level
0x50001184	UART2_RFL_REG	Receive FIFO Level
0x50001188	UART2_SRR_REG	Software Reset Register.
0x50001190	UART2_SBCR_REG	Shadow Break Control Register
0x50001194	UART2_SDMAM_REG	Shadow DMA Mode
0x50001198	UART2_SFE_REG	Shadow FIFO Enable
0x5000119C	UART2_SRT_REG	Shadow RCVR Trigger
0x500011A0	UART2_STET_REG	Shadow TX Empty Trigger
0x500011A4	UART2_HTX_REG	Halt TX
0x500011A8	UART2_DMASA_REG	DMA Software Acknowledge
0x500011C0	UART2_DLF_REG	Divisor Latch Fraction Register
0x500011F8	UART2_UCV_REG	Component Version
0x500011FA	UART2_UCV_HIGH_REG	Component Version
0x500011FC	UART2_CTR_REG	Component Type Register
0x500011FE	UART2_CTR_HIGH_REG	Component Type Register

Table 341: UART\_RBR\_THR\_DLL\_REG (0x50001000)

Bit	Mode	Symbol	Description	Reset
15:8	-	-		0x0
7:0	R/W	RBR_THR_DLL	Receive Buffer Register: (RBR).	0x0

Bit	Mode	Symbol	Description	Reset
			<p>This register contains the data byte received on the serial input port (sin) in UART mode. The data in this register is valid only if the Data Ready (DR) bit in the Line status Register (LSR) is set. If FIFOs are disabled (FCR[0] set to zero), the data in the RBR must be read before the next data arrives, otherwise it will be overwritten, resulting in an overrun error. If FIFOs are enabled (FCR[0] set to one), this register accesses the head of the receive FIFO. If the receive FIFO is full and this register is not read before the next data character arrives, then the data already in the FIFO will be preserved but any incoming data will be lost. An overrun error will also occur.</p> <p><b>Transmit Holding Register: (THR)</b></p> <p>This register contains data to be transmitted on the serial output port (sout) in UART mode. Data should only be written to the THR when the THR Empty (THRE) bit (LSR[5]) is set. If FIFO's are disabled (FCR[0] set to zero) and THRE is set, writing a single character to the THR clears the THRE. Any additional writes to the THR before the THRE is set again causes the THR data to be overwritten. If FIFO's are enabled (FCR[0] set to one) and THRE is set, 16 number of characters of data may be written to the THR before the FIFO is full. Any attempt to write data when the FIFO is full results in the write data being lost.</p> <p><b>Divisor Latch (Low): (DLL)</b></p> <p>This register makes up the lower 8-bits of a 16-bit, read/write, Divisor Latch register that contains the baud rate divisor for the UART. This register may only be accessed when the DLAB bit (LCR[7]) is set. The output baud rate is equal to the serial clock (sclk) frequency divided by sixteen times the value of the baud rate divisor, as follows:</p> $\text{baud rate} = (\text{serial clock freq}) / (16 * \text{divisor})$ <p>Note that with the Divisor Latch Registers (DLL and DLH) set to zero, the baud clock is disabled and no serial communications will occur. Also, once the Divisor Latch is set, at least 8 clock cycles of the slowest UART clock should be allowed to pass before transmitting or receiving data.</p> <p>For the Divisor Latch (High) bits, see register UART_IER_DLH_REG.</p>	

Table 342: UART\_IER\_DLH\_REG (0x50001004)

Bit	Mode	Symbol	Description	Reset
15:8	-	-		0x0
7	R/W	PTIME_dlh7	<p><b>Interrupt Enable Register: PTIME,</b> Programmable THRE Interrupt Mode Enable. This is used to enable/disable the generation of THRE Interrupt. 0 = disabled 1 = enabled.</p> <p><b>Divisor Latch (High): DLH7,</b> Bit 7 of the upper part of a 16-bit, read/write, Divisor Latch register that contains the baud rate divisor for the UART.</p>	0x0

Bit	Mode	Symbol	Description	Reset
			This register may be accessed only when the DLAB bit (LCR[7]) is set. See register UART_RBR_THR_DLL_REG.	
6:4	R/W	dlh6_4	<b>Divisor Latch (High): DLH6 to DLH4</b> , Bits 6 to 4 of the upper part of a 16-bit, read/write, Divisor Latch register that contains the baud rate divisor for the UART. This register may be accessed only when the DLAB bit (LCR[7]) is set, otherwise, this field is reserved. See register UART_RBR_THR_DLL_REG.	0x0
3	R/W	EDSSI_dlh3	<b>Interrupt Enable Register: EDSSI</b> , Enable Modem Status Interrupt. This is used to enable/disable the generation of Modem Status Interrupt. This is the fourth highest priority interrupt. 0 = disabled 1 = enabled <b>Divisor Latch (High): DLH3</b> , Bit 3 of the upper part of a 16-bit, read/write, Divisor Latch register that contains the baud rate divisor for the UART. This register may be accessed only when the DLAB bit (LCR[7]) is set. See register UART_RBR_THR_DLL_REG.	0x0
2	R/W	ELSI_dlh2	<b>Interrupt Enable Register: ELSI</b> , Enable Receiver Line Status Interrupt. This is used to enable/disable the generation of Receiver Line Status Interrupt. This is the highest priority interrupt. 0 = disabled 1 = enabled <b>Divisor Latch (High): DLH2</b> , Bit 2 of the upper part of a 16-bit, read/write, Divisor Latch register that contains the baud rate divisor for the UART. This register may be accessed only when the DLAB bit (LCR[7]) is set. See register UART_RBR_THR_DLL_REG.	0x0
1	R/W	ETBEI_dlh1	<b>Interrupt Enable Register: ETBEI</b> , Enable Transmit Holding Register Empty Interrupt. This is used to enable/disable the generation of Transmitter Holding Register Empty Interrupt. This is the third highest priority interrupt. 0 = disabled 1 = enabled <b>Divisor Latch (High): DLH1</b> , Bit 1 of the upper part of a 16-bit, read/write, Divisor Latch register that contains the baud rate divisor for the UART. This register may be accessed only when the DLAB bit (LCR[7]) is set. See register UART_RBR_THR_DLL_REG.	0x0
0	R/W	ERBFI_dlh0	<b>Interrupt Enable Register: ERBFI</b> , Enable Received Data Available Interrupt. This is used to enable/disable the generation of Received Data Available Interrupt and the Character Timeout Interrupt (if in FIFO mode and FIFO's enabled). These are the second highest priority interrupts. 0 = disabled 1 = enabled <b>Divisor Latch (High): DLH0</b> , Bit 0 of the upper part of a 16-bit, read/write, Divisor Latch register that contains the baud rate divisor for the UART. This register may be accessed only when the DLAB bit (LCR[7]) is set. See register UART_RBR_THR_DLL_REG.	0x0

Table 343: UART\_IIR\_FCR\_REG (0x50001008)

Bit	Mode	Symbol	Description	Reset
7:6	R/W	UART_FIFOSE_RT	<p>On read</p> <p>FIFO's Enabled (or FIFOSE): This is used to indicate whether the FIFO's are enabled or disabled. 00 = disabled. 11 = enabled.</p> <p>On write</p> <p>RCVR Trigger (or RT):. This is used to select the trigger level in the receiver FIFO at which the Received Data Available Interrupt will be generated. In auto flow control mode it is used to determine when the rts_n signal will be de-asserted. It also determines when the dma_rx_req_n signal will be asserted when in certain modes of operation. The following trigger levels are supported: 00 = 1 character in the FIFO 01 = FIFO 1/4 full 10 = FIFO 1/2 full 11 = FIFO 2 less than full</p>	0x0
5:4	R0/W	UART_TET	<p>On read</p> <p>reserved</p> <p>On Write</p> <p>TX Empty Trigger (or TET): This is used to select the empty threshold level at which the THRE Interrupts will be generated when the mode is active. It also determines when the dma_tx_req_n signal will be asserted when in certain modes of operation. The following trigger levels are supported: 00 = FIFO empty 01 = 2 characters in the FIFO 10 = FIFO 1/4 full 11 = FIFO 1/2 full</p>	0x0
3	R/W	UART_IID3_DMAM	<p>On Read (Bit3)</p> <p>Interrupt ID (or IID): This indicates the highest priority pending interrupt which can be one of the following types:</p> <p>0001 = no interrupt pending.  0010 = THR empty.  0100 = received data available.  0110 = receiver line status.  0111 = busy detect.  1100 = character timeout.</p> <p>On Write</p> <p>DMA Mode (or DMAM): This determines the DMA signalling mode used for the dma_tx_req_n and dma_rx_req_n output signals. 0 = mode 0 1 = mode 1</p>	0x0
2	R/W	UART_IID2_XFIFOR	<p>On Read (Bit2)</p> <p>Interrupt ID (or IID): This indicates the highest priority pending interrupt which can be one of the following types:</p> <p>0001 = no interrupt pending.  0010 = THR empty.  0100 = received data available.  0110 = receiver line status.  0111 = busy detect.  1100 = character timeout.</p> <p>On Write</p>	0x0



Bit	Mode	Symbol	Description	Reset
			XMIT FIFO Reset (or XFIFOR): This resets the control portion of the transmit FIFO and treats the FIFO as empty. Note that this bit is 'self-clearing' and it is not necessary to clear this bit.	
1	R/W	UART_IID1_RFIFOE	<p>On Read (Bit1)</p> <p>Interrupt ID (or IID): This indicates the highest priority pending interrupt which can be one of the following types:</p> <p>0001 = no interrupt pending.  0010 = THR empty.  0100 = received data available.  0110 = receiver line status.  0111 = busy detect.  1100 = character timeout.</p> <p>On Write</p> <p>RCVR FIFO Reset (or RFIFOR): This resets the control portion of the receive FIFO and treats the FIFO as empty. Note that this bit is 'self-clearing' and it is not necessary to clear this bit.</p>	0x0
0	R/W	UART_IID0_FIFOE	<p>On Read (Bit0)</p> <p>Interrupt ID (or IID): This indicates the highest priority pending interrupt which can be one of the following types:</p> <p>0001 = no interrupt pending.  0010 = THR empty.  0100 = received data available.  0110 = receiver line status.  0111 = busy detect.  1100 = character timeout.</p> <p>On Write</p> <p>FIFO Enable (or FIFOE): This enables/disables the transmit (XMIT) and receive (RCVR) FIFO's. Whenever the value of this bit is changed both the XMIT and RCVR controller portion of FIFO's will be reset</p>	0x1

Table 344: UART\_LCR\_REG (0x5000100C)

Bit	Mode	Symbol	Description	Reset
15:8	-	-		0x0
7	R/W	UART_DLAB	<p>Divisor Latch Access Bit. Writeable only when UART is not busy (USR[0] is zero).</p> <p>This bit is used to enable reading and writing of the Divisor Latch register (DLL and DLH) to set the baud rate of the UART.</p> <p>This bit must be cleared after initial baud rate setup in order to access other registers.</p>	0x0
6	R/W	UART_BC	<p>Break Control Bit.</p> <p>This is used to cause a break condition to be transmitted to the receiving device. If set to one the serial output is forced to the spacing (logic 0) state. When not in Loopback Mode, as determined</p>	0x0

Bit	Mode	Symbol	Description	Reset
			by MCR[4], the sout line is forced low until the Break bit is cleared. If active (MCR[6] set to one) the sir_out_n line is continuously pulsed. When in Loopback Mode, the break condition is internally looped back to the receiver and the sir_out_n line is forced low.	
5	-	-		0x0
4	R/W	UART_EPS	Even Parity Select. Writeable only when UART is not busy (USR[0] is zero).  This is used to select between even and odd parity, when parity is enabled (PEN set to one). If set to one, an even number of logic 1s is transmitted or checked. If set to zero, an odd number of logic 1s is transmitted or checked.	0x0
3	R/W	UART_PEN	Parity Enable. Writeable only when UART is not busy (USR[0] is zero)  This bit is used to enable and disable parity generation and detection in transmitted and received serial character respectively.  0 = parity disabled 1 = parity enabled	0x0
2	R/W	UART_STOP	Number of stop bits. Writeable only when UART is not busy (USR[0] is zero).  This is used to select the number of stop bits per character that the peripheral transmits and receives. If set to zero, one stop bit is transmitted in the serial data.  If set to one and the data bits are set to 5 (LCR[1:0] set to zero) one and a half stop bits is transmitted. Otherwise, two stop bits are transmitted. Note that regardless of the number of stop bits selected, the receiver checks only the first stop bit.  0 = 1 stop bit 1 = 1.5 stop bits when DLS (LCR[1:0]) is zero, else 2 stop bit	0x0
1:0	R/W	UART_DLS	Data Length Select. Writeable only when UART is not busy (USR[0] is zero).  This is used to select the number of data bits per character that the peripheral transmits and receives. The number of bit that may be selected areas follows:  00 = 5 bits 01 = 6 bits 10 = 7 bits 11 = 8 bits	0x0

Table 345: UART\_MCR\_REG (0x50001010)

Bit	Mode	Symbol	Description	Reset
15:7	-	-		0x0
6	-	-		0x0

Bit	Mode	Symbol	Description	Reset
5	R/W	UART_AFCE	Auto Flow Control Enable. When FIFOs are enabled and the Auto Flow Control Enable (AFCE) bit is set, Auto Flow Control features are enabled. 0 = Auto Flow Control Mode disabled 1 = Auto Flow Control Mode enabled	0x0
4	R/W	UART_LB	LoopBack Bit. This is used to put the UART into a diagnostic mode for test purposes. If operating in UART mode (SIR_MODE not active, MCR[6] set to zero), data on the sout line is held high, while serial data output is looped back to the sin line, internally. In this mode all the interrupts are fully functional. Also, in loopback mode, the modem control inputs (dsr_n, cts_n, ri_n, dcd_n) are disconnected and the modem control outputs (dtr_n, rts_n, out1_n, out2_n) are looped back to the inputs, internally. If operating in infrared mode (SIR_MODE active, MCR[6] set to one), data on the sir_out_n line is held low, while serial data output is inverted and looped back to the sir_in line.	0x0
3	-	-		0x0
2	-	-		0x0
1	R/W	UART_RTS	Request to Send. This is used to directly control the Request to Send (rts_n) output. The Request To Send (rts_n) output is used to inform the modem or data set that the UART is ready to exchange data. When Auto RTS Flow Control is not enabled (MCR[5] set to zero), the rts_n signal is set low by programming MCR[1] (RTS) to a high. In Auto Flow Control, AFCE_MODE == Enabled and active (MCR[5] set to one) and FIFOs enable (FCR[0] set to one), the rts_n output is controlled in the same way, but is also gated with the receiver FIFO threshold trigger (rts_n is inactive high when above the threshold). The rts_n signal is de-asserted when MCR[1] is set low. Note that in Loopback mode (MCR[4] set to one), the rts_n output is held inactive high while the value of this location is internally looped back to an input.	0x0
0	-	-		0x0

Table 346: UART\_LSR\_REG (0x50001014)

Bit	Mode	Symbol	Description	Reset
15:8	-	-		0x0
7	R	UART_RFE	Receiver FIFO Error bit. This bit is only relevant when FIFOs are enabled (FCR[0] set to one). This is used to indicate if	0x0

Bit	Mode	Symbol	Description	Reset
			<p>there is at least one parity error, framing error, or break indication in the FIFO.</p> <p>0 = no error in RX FIFO 1 = error in RX FIFO</p> <p>This bit is cleared when the LSR is read and the character with the error is at the top of the receiver FIFO and there are no subsequent errors in the FIFO.</p>	
6	R	UART_TEMT	<p>Transmitter Empty bit.</p> <p>If FIFOs enabled (FCR[0] set to one), this bit is set whenever the Transmitter Shift Register and the FIFO are both empty. If FIFOs are disabled, this bit is set whenever the Transmitter Holding Register(THR) and the Transmitter Shift Register are both empty.</p>	0x1
5	R	UART_THRE	<p>Transmit Holding Register Empty bit.</p> <p>If THRE mode is disabled (IER[7] set to zero) and regardless of FIFO's being implemented/enabled or not, this bit indicates that the THR or TX FIFO is empty.</p> <p>This bit is set whenever data is transferred from the THR or TX FIFO to the transmitter shift register and no new data has been written to the THR or TX FIFO. This also causes a THRE Interrupt to occur, if the THRE Interrupt is enabled. If both modes are active (IER[7] set to one and FCR[0] set to one respectively), the functionality is switched to indicate the transmitter FIFO is full, and no longer controls THRE interrupts, which are then controlled by the FCR[5:4] threshold setting.</p>	0x1
4	R	UART_BI	<p>Break Interrupt bit.</p> <p>This is used to indicate the detection of a break sequence on the serial input data.</p> <p>If in UART mode (SIR_MODE == Disabled), it is set whenever the serial input, sin, is held in a logic '0' state for longer than the sum of start time + data bits + parity + stop bits.</p> <p>If in infrared mode (SIR_MODE == Enabled), it is set whenever the serial input, sir_in, is continuously pulsed to logic '0' for longer than the sum of start time + data bits + parity + stop bits. A break condition on serial input causes one and only one character, consisting of all zeros, to be received by the UART.</p> <p>In the FIFO mode, the character associated with the break condition is carried through the FIFO and is revealed when the character is at the top of the FIFO.</p> <p>Reading the LSR clears the BI bit. In the non-FIFO mode, the BI indication occurs immediately and persists until the LSR is read.</p>	0x0
3	R	UART_FE	<p>Framing Error bit.</p> <p>This is used to indicate the occurrence of a framing error in the receiver. A framing error occurs when the receiver does not detect a valid STOP bit in the received data.</p>	0x0

Bit	Mode	Symbol	Description	Reset
			<p>In the FIFO mode, since the framing error is associated with a character received, it is revealed when the character with the framing error is at the top of the FIFO.</p> <p>When a framing error occurs, the UART tries to resynchronize. It does this by assuming that the error was due to the start bit of the next character and then continues receiving the other bit i.e. data, and/or parity and stop. It should be noted that the Framing Error (FE) bit (LSR[3]) is set if a break interrupt has occurred, as indicated by Break Interrupt (BI) bit (LSR[4]).</p> <p>0 = no framing error 1 = framing error</p> <p>Reading the LSR clears the FE bit.</p>	
2	R	UART_PE	<p>Parity Error bit.</p> <p>This is used to indicate the occurrence of a parity error in the receiver if the Parity Enable (PEN) bit (LCR[3]) is set.</p> <p>In the FIFO mode, since the parity error is associated with a character received, it is revealed when the character with the parity error arrives at the top of the FIFO.</p> <p>It should be noted that the Parity Error (PE) bit (LSR[2]) is set if a break interrupt has occurred, as indicated by Break Interrupt (BI) bit (LSR[4]).</p> <p>0 = no parity error 1 = parity error</p> <p>Reading the LSR clears the PE bit.</p>	0x0
1	R	UART_OE	<p>Overrun error bit.</p> <p>This is used to indicate the occurrence of an overrun error.</p> <p>This occurs if a new data character was received before the previous data was read.</p> <p>In the non-FIFO mode, the OE bit is set when a new character arrives in the receiver before the previous character was read from the RBR. When this happens, the data in the RBR is overwritten.</p> <p>In the FIFO mode, an overrun error occurs when the FIFO is full and a new character arrives at the receiver. The data in the FIFO is retained and the data in the receive shift register is lost.</p> <p>0 = no overrun error 1 = overrun error</p> <p>Reading the LSR clears the OE bit.</p>	0x0
0	R	UART_DR	<p>Data Ready bit.</p> <p>This is used to indicate that the receiver contains at least one character in the RBR or the receiver FIFO.</p> <p>0 = no data ready 1 = data ready</p> <p>This bit is cleared when the RBR is read in non-FIFO mode, or when the receiver FIFO is empty, in FIFO mode.</p>	0x0

Table 347: **UART\_MSR\_REG (0x50001018)**

Bit	Mode	Symbol	Description	Reset
15:5	-	-		0x0
4	R	UART_CTS	<p>Clear to Send.</p> <p>This is used to indicate the current state of the modem control line cts_n. This bit is the complement of cts_n. When the Clear to Send input (cts_n) is asserted it is an indication that the modem or data set is ready to exchange data with the UART Ctrl.</p> <p>0 = cts_n input is de-asserted (logic 1) 1 = cts_n input is asserted (logic 0)</p> <p>In Loopback Mode (MCR[4] = 1), CTS is the same as MCR[1] (RTS).</p>	0x1
3:1	-	-		0x0
0	-	-		0x0

Table 348: **UART\_SCR\_REG (0x5000101C)**

Bit	Mode	Symbol	Description	Reset
15:8	-	-		0x0
7:0	R/W	UART_SCRATCH_PAD	This register is for programmers to use as a temporary storage space. It has no defined purpose in the UART Ctrl.	0x0

Table 349: **UART\_SRBR\_STHR0\_REG (0x50001030)**

Bit	Mode	Symbol	Description	Reset
15:8	-	-		0x0
7:0	R/W	SRBR_STHRx	<p>Shadow Receive Buffer Register x: This is a shadow register for the RBR and has been allocated sixteen 32-bit locations so as to accommodate burst accesses from the master. This register contains the data byte received on the serial input port (sin) in UART mode or the serial infrared input (sir_in) in infrared mode. The data in this register is valid only if the Data Ready (DR) bit in the Line status Register (LSR) is set. If FIFOs are disabled (FCR[0] set to zero), the data in the RBR must be read before the next data arrives, otherwise it will be overwritten, resulting in an overrun error. If FIFOs are enabled (FCR[0] set to one), this register accesses the head of the receive FIFO. If the receive FIFO is full and this register is not read before the next data character arrives, then the data already in the FIFO will be preserved but any incoming data will be lost. An overrun error will also occur. Shadow Transmit Holding Register 0: This is a shadow register for the THR and has been allocated sixteen 32-bit locations so as to accommodate burst accesses from the master. This register contains data to be transmitted on the serial output port (sout) in</p>	0x0

Bit	Mode	Symbol	Description	Reset
			UART mode or the serial infrared output (sir_out_n) in infrared mode. Data should only be written to the THR when the THR Empty (THRE) bit (LSR[5]) is set. If FIFO's are disabled (FCR[0] set to zero) and THRE is set, writing a single character to the THR clears the THRE. Any additional writes to the THR before the THRE is set again causes the THR data to be overwritten. If FIFO's are enabled (FCR[0] set to one) and THRE is set, x number of characters of data may be written to the THR before the FIFO is full. The number x (default=16) is determined by the value of FIFO Depth that you set during configuration. Any attempt to write data when the FIFO is full results in the write data being lost.	

Table 350: UART\_SRBR\_STHR1\_REG (0x50001034)

Bit	Mode	Symbol	Description	Reset
15:8	-	-		0x0
7:0	R/W	SRBR_STHRx	Shadow Receive Buffer Register x: This is a shadow register for the RBR and has been allocated sixteen 32-bit locations so as to accommodate burst accesses from the master. This register contains the data byte received on the serial input port (sin) in UART mode or the serial infrared input (sir_in) in infrared mode. The data in this register is valid only if the Data Ready (DR) bit in the Line status Register (LSR) is set. If FIFOs are disabled (FCR[0] set to zero), the data in the RBR must be read before the next data arrives, otherwise it will be overwritten, resulting in an overrun error. If FIFOs are enabled (FCR[0] set to one), this register accesses the head of the receive FIFO. If the receive FIFO is full and this register is not read before the next data character arrives, then the data already in the FIFO will be preserved but any incoming data will be lost. An overrun error will also occur. Shadow Transmit Holding Register 0: This is a shadow register for the THR and has been allocated sixteen 32-bit locations so as to accommodate burst accesses from the master. This register contains data to be transmitted on the serial output port (sout) in UART mode or the serial infrared output (sir_out_n) in infrared mode. Data should only be written to the THR when the THR Empty (THRE) bit (LSR[5]) is set. If FIFO's are disabled (FCR[0] set to zero) and THRE is set, writing a single character to the THR clears the THRE. Any additional writes to the THR before the THRE is set again causes the THR data to be overwritten. If FIFO's are enabled (FCR[0] set to one) and THRE is set, x number of characters of data may be written to the THR before the FIFO is full. The number x (default=16) is determined by the value of FIFO Depth that you set during configuration. Any attempt to write data when the FIFO is full results in the write data being lost.	0x0

Table 351: UART\_SRBR\_STHR2\_REG (0x50001038)

Bit	Mode	Symbol	Description	Reset
15:8	-	-		0x0
7:0	R/W	SRBR_STHRx	Shadow Receive Buffer Register x: This is a shadow register for the RBR and has been allocated sixteen 32-bit locations so as to accommodate burst accesses from the master. This register contains the data byte received on the serial input port (sin) in UART mode or the serial infrared input (sir_in) in infrared mode. The data in this register is valid only if the Data Ready (DR) bit in the Line status Register (LSR) is set. If FIFOs are disabled (FCR[0] set to zero), the data in the RBR must be read before the next data arrives, otherwise it will be overwritten, resulting in an overrun error. If FIFOs are enabled (FCR[0] set to one), this register accesses the head of the receive FIFO. If the receive FIFO is full and this register is not read before the next data character arrives, then the data already in the FIFO will be preserved but any incoming data will be lost. An overrun error will also occur. Shadow Transmit Holding Register 0: This is a shadow register for the THR and has been allocated sixteen 32-bit locations so as to accommodate burst accesses from the master. This register contains data to be transmitted on the serial output port (sout) in UART mode or the serial infrared output (sir_out_n) in infrared mode. Data should only be written to the THR when the THR Empty (THRE) bit (LSR[5]) is set. If FIFO's are disabled (FCR[0] set to zero) and THRE is set, writing a single character to the THR clears the THRE. Any additional writes to the THR before the THRE is set again causes the THR data to be overwritten. If FIFO's are enabled (FCR[0] set to one) and THRE is set, x number of characters of data may be written to the THR before the FIFO is full. The number x (default=16) is determined by the value of FIFO Depth that you set during configuration. Any attempt to write data when the FIFO is full results in the write data being lost.	0x0

Table 352: UART\_SRBR\_STHR3\_REG (0x5000103C)

Bit	Mode	Symbol	Description	Reset
15:8	-	-		0x0
7:0	R/W	SRBR_STHRx	Shadow Receive Buffer Register x: This is a shadow register for the RBR and has been allocated sixteen 32-bit locations so as to accommodate burst accesses from the master. This register contains the data byte received on the serial input port (sin) in UART mode or the serial infrared input (sir_in) in infrared mode. The data in this register is valid only if the Data Ready (DR) bit in the Line status Register (LSR) is set. If FIFOs are disabled (FCR[0] set to zero), the data	0x0



Bit	Mode	Symbol	Description	Reset
			<p>in the RBR must be read before the next data arrives, otherwise it will be overwritten, resulting in an overrun error. If FIFOs are enabled (FCR[0] set to one), this register accesses the head of the receive FIFO. If the receive FIFO is full and this register is not read before the next data character arrives, then the data already in the FIFO will be preserved but any incoming data will be lost. An overrun error will also occur. Shadow Transmit Holding Register 0: This is a shadow register for the THR and has been allocated sixteen 32-bit locations so as to accommodate burst accesses from the master. This register contains data to be transmitted on the serial output port (sout) in UART mode or the serial infrared output (sir_out_n) in infrared mode. Data should only be written to the THR when the THR Empty (THRE) bit (LSR[5]) is set. If FIFO's are disabled (FCR[0] set to zero) and THRE is set, writing a single character to the THR clears the THRE. Any additional writes to the THR before the THRE is set again causes the THR data to be overwritten. If FIFO's are enabled (FCR[0] set to one) and THRE is set, x number of characters of data may be written to the THR before the FIFO is full. The number x (default=16) is determined by the value of FIFO Depth that you set during configuration. Any attempt to write data when the FIFO is full results in the write data being lost.</p>	

Table 353: UART\_SRBR\_STHR4\_REG (0x50001040)

Bit	Mode	Symbol	Description	Reset
15:8	-	-		0x0
7:0	R/W	SRBR_STHRx	<p>Shadow Receive Buffer Register x: This is a shadow register for the RBR and has been allocated sixteen 32-bit locations so as to accommodate burst accesses from the master. This register contains the data byte received on the serial input port (sin) in UART mode or the serial infrared input (sir_in) in infrared mode. The data in this register is valid only if the Data Ready (DR) bit in the Line status Register (LSR) is set. If FIFOs are disabled (FCR[0] set to zero), the data in the RBR must be read before the next data arrives, otherwise it will be overwritten, resulting in an overrun error. If FIFOs are enabled (FCR[0] set to one), this register accesses the head of the receive FIFO. If the receive FIFO is full and this register is not read before the next data character arrives, then the data already in the FIFO will be preserved but any incoming data will be lost. An overrun error will also occur. Shadow Transmit Holding Register 0: This is a shadow register for the THR and has been allocated sixteen 32-bit locations so as to accommodate burst accesses from the master. This register contains data to be transmitted on the serial output port (sout) in UART mode or the serial infrared output (sir_out_n) in infrared mode. Data should only be</p>	0x0

Bit	Mode	Symbol	Description	Reset
			written to the THR when the THR Empty (THRE) bit (LSR[5]) is set. If FIFO's are disabled (FCR[0] set to zero) and THRE is set, writing a single character to the THR clears the THRE. Any additional writes to the THR before the THRE is set again causes the THR data to be overwritten. If FIFO's are enabled (FCR[0] set to one) and THRE is set, x number of characters of data may be written to the THR before the FIFO is full. The number x (default=16) is determined by the value of FIFO Depth that you set during configuration. Any attempt to write data when the FIFO is full results in the write data being lost.	

Table 354: UART\_SRBR\_STHR5\_REG (0x50001044)

Bit	Mode	Symbol	Description	Reset
15:8	-	-		0x0
7:0	R/W	SRBR_STHRx	Shadow Receive Buffer Register x: This is a shadow register for the RBR and has been allocated sixteen 32-bit locations so as to accommodate burst accesses from the master. This register contains the data byte received on the serial input port (sin) in UART mode or the serial infrared input (sir_in) in infrared mode. The data in this register is valid only if the Data Ready (DR) bit in the Line status Register (LSR) is set. If FIFOs are disabled (FCR[0] set to zero), the data in the RBR must be read before the next data arrives, otherwise it will be overwritten, resulting in an overrun error. If FIFOs are enabled (FCR[0] set to one), this register accesses the head of the receive FIFO. If the receive FIFO is full and this register is not read before the next data character arrives, then the data already in the FIFO will be preserved but any incoming data will be lost. An overrun error will also occur. Shadow Transmit Holding Register 0: This is a shadow register for the THR and has been allocated sixteen 32-bit locations so as to accommodate burst accesses from the master. This register contains data to be transmitted on the serial output port (sout) in UART mode or the serial infrared output (sir_out_n) in infrared mode. Data should only be written to the THR when the THR Empty (THRE) bit (LSR[5]) is set. If FIFO's are disabled (FCR[0] set to zero) and THRE is set, writing a single character to the THR clears the THRE. Any additional writes to the THR before the THRE is set again causes the THR data to be overwritten. If FIFO's are enabled (FCR[0] set to one) and THRE is set, x number of characters of data may be written to the THR before the FIFO is full. The number x (default=16) is determined by the value of FIFO Depth that you set during configuration. Any attempt to write data when the FIFO is full results in the write data being lost.	0x0

Table 355: UART\_SRBR\_STHR6\_REG (0x50001048)

Bit	Mode	Symbol	Description	Reset
15:8	-	-		0x0
7:0	R/W	SRBR_STHRx	Shadow Receive Buffer Register x: This is a shadow register for the RBR and has been allocated sixteen 32-bit locations so as to accommodate burst accesses from the master. This register contains the data byte received on the serial input port (sin) in UART mode or the serial infrared input (sir_in) in infrared mode. The data in this register is valid only if the Data Ready (DR) bit in the Line status Register (LSR) is set. If FIFOs are disabled (FCR[0] set to zero), the data in the RBR must be read before the next data arrives, otherwise it will be overwritten, resulting in an overrun error. If FIFOs are enabled (FCR[0] set to one), this register accesses the head of the receive FIFO. If the receive FIFO is full and this register is not read before the next data character arrives, then the data already in the FIFO will be preserved but any incoming data will be lost. An overrun error will also occur. Shadow Transmit Holding Register 0: This is a shadow register for the THR and has been allocated sixteen 32-bit locations so as to accommodate burst accesses from the master. This register contains data to be transmitted on the serial output port (sout) in UART mode or the serial infrared output (sir_out_n) in infrared mode. Data should only be written to the THR when the THR Empty (THRE) bit (LSR[5]) is set. If FIFO's are disabled (FCR[0] set to zero) and THRE is set, writing a single character to the THR clears the THRE. Any additional writes to the THR before the THRE is set again causes the THR data to be overwritten. If FIFO's are enabled (FCR[0] set to one) and THRE is set, x number of characters of data may be written to the THR before the FIFO is full. The number x (default=16) is determined by the value of FIFO Depth that you set during configuration. Any attempt to write data when the FIFO is full results in the write data being lost.	0x0

Table 356: UART\_SRBR\_STHR7\_REG (0x5000104C)

Bit	Mode	Symbol	Description	Reset
15:8	-	-		0x0
7:0	R/W	SRBR_STHRx	Shadow Receive Buffer Register x: This is a shadow register for the RBR and has been allocated sixteen 32-bit locations so as to accommodate burst accesses from the master. This register contains the data byte received on the serial input port (sin) in UART mode or the serial infrared input (sir_in) in infrared mode. The data in this register is valid only if the Data Ready (DR) bit in the Line status Register (LSR) is set. If FIFOs are disabled (FCR[0] set to zero), the data in the RBR must be read before the next data arrives, otherwise it will be overwritten, resulting in	0x0

Bit	Mode	Symbol	Description	Reset
			<p>an overrun error. If FIFOs are enabled (FCR[0] set to one), this register accesses the head of the receive FIFO. If the receive FIFO is full and this register is not read before the next data character arrives, then the data already in the FIFO will be preserved but any incoming data will be lost. An overrun error will also occur. Shadow Transmit Holding Register 0: This is a shadow register for the THR and has been allocated sixteen 32-bit locations so as to accommodate burst accesses from the master. This register contains data to be transmitted on the serial output port (sout) in UART mode or the serial infrared output (sir_out_n) in infrared mode. Data should only be written to the THR when the THR Empty (THRE) bit (LSR[5]) is set. If FIFO's are disabled (FCR[0] set to zero) and THRE is set, writing a single character to the THR clears the THRE. Any additional writes to the THR before the THRE is set again causes the THR data to be overwritten. If FIFO's are enabled (FCR[0] set to one) and THRE is set, x number of characters of data may be written to the THR before the FIFO is full. The number x (default=16) is determined by the value of FIFO Depth that you set during configuration. Any attempt to write data when the FIFO is full results in the write data being lost.</p>	

Table 357: UART\_SRBR\_STHR8\_REG (0x50001050)

Bit	Mode	Symbol	Description	Reset
15:8	-	-		0x0
7:0	R/W	SRBR_STHRx	<p>Shadow Receive Buffer Register x: This is a shadow register for the RBR and has been allocated sixteen 32-bit locations so as to accommodate burst accesses from the master. This register contains the data byte received on the serial input port (sin) in UART mode or the serial infrared input (sir_in) in infrared mode. The data in this register is valid only if the Data Ready (DR) bit in the Line status Register (LSR) is set. If FIFOs are disabled (FCR[0] set to zero), the data in the RBR must be read before the next data arrives, otherwise it will be overwritten, resulting in an overrun error. If FIFOs are enabled (FCR[0] set to one), this register accesses the head of the receive FIFO. If the receive FIFO is full and this register is not read before the next data character arrives, then the data already in the FIFO will be preserved but any incoming data will be lost. An overrun error will also occur. Shadow Transmit Holding Register 0: This is a shadow register for the THR and has been allocated sixteen 32-bit locations so as to accommodate burst accesses from the master. This register contains data to be transmitted on the serial output port (sout) in UART mode or the serial infrared output (sir_out_n) in infrared mode. Data should only be written to the THR when the THR Empty (THRE) bit (LSR[5]) is set. If FIFO's are disabled (FCR[0]</p>	0x0

Bit	Mode	Symbol	Description	Reset
			set to zero) and THRE is set, writing a single character to the THR clears the THRE. Any additional writes to the THR before the THRE is set again causes the THR data to be overwritten. If FIFO's are enabled (FCR[0] set to one) and THRE is set, x number of characters of data may be written to the THR before the FIFO is full. The number x (default=16) is determined by the value of FIFO Depth that you set during configuration. Any attempt to write data when the FIFO is full results in the write data being lost.	

Table 358: UART\_SRBR\_STHR9\_REG (0x50001054)

Bit	Mode	Symbol	Description	Reset
15:8	-	-		0x0
7:0	R/W	SRBR_STHRx	Shadow Receive Buffer Register x: This is a shadow register for the RBR and has been allocated sixteen 32-bit locations so as to accommodate burst accesses from the master. This register contains the data byte received on the serial input port (sin) in UART mode or the serial infrared input (sir_in) in infrared mode. The data in this register is valid only if the Data Ready (DR) bit in the Line status Register (LSR) is set. If FIFOs are disabled (FCR[0] set to zero), the data in the RBR must be read before the next data arrives, otherwise it will be overwritten, resulting in an overrun error. If FIFOs are enabled (FCR[0] set to one), this register accesses the head of the receive FIFO. If the receive FIFO is full and this register is not read before the next data character arrives, then the data already in the FIFO will be preserved but any incoming data will be lost. An overrun error will also occur. Shadow Transmit Holding Register 0: This is a shadow register for the THR and has been allocated sixteen 32-bit locations so as to accommodate burst accesses from the master. This register contains data to be transmitted on the serial output port (sout) in UART mode or the serial infrared output (sir_out_n) in infrared mode. Data should only be written to the THR when the THR Empty (THRE) bit (LSR[5]) is set. If FIFO's are disabled (FCR[0] set to zero) and THRE is set, writing a single character to the THR clears the THRE. Any additional writes to the THR before the THRE is set again causes the THR data to be overwritten. If FIFO's are enabled (FCR[0] set to one) and THRE is set, x number of characters of data may be written to the THR before the FIFO is full. The number x (default=16) is determined by the value of FIFO Depth that you set during configuration. Any attempt to write data when the FIFO is full results in the write data being lost.	0x0

Table 359: UART\_SRBR\_STHR10\_REG (0x50001058)

Bit	Mode	Symbol	Description	Reset
15:8	-	-		0x0
7:0	R/W	SRBR_STHRx	<p>Shadow Receive Buffer Register x: This is a shadow register for the RBR and has been allocated sixteen 32-bit locations so as to accommodate burst accesses from the master. This register contains the data byte received on the serial input port (sin) in UART mode or the serial infrared input (sir_in) in infrared mode. The data in this register is valid only if the Data Ready (DR) bit in the Line status Register (LSR) is set. If FIFOs are disabled (FCR[0] set to zero), the data in the RBR must be read before the next data arrives, otherwise it will be overwritten, resulting in an overrun error. If FIFOs are enabled (FCR[0] set to one), this register accesses the head of the receive FIFO. If the receive FIFO is full and this register is not read before the next data character arrives, then the data already in the FIFO will be preserved but any incoming data will be lost. An overrun error will also occur.</p> <p>Shadow Transmit Holding Register 0: This is a shadow register for the THR and has been allocated sixteen 32-bit locations so as to accommodate burst accesses from the master. This register contains data to be transmitted on the serial output port (sout) in UART mode or the serial infrared output (sir_out_n) in infrared mode. Data should only be written to the THR when the THR Empty (THRE) bit (LSR[5]) is set. If FIFO's are disabled (FCR[0] set to zero) and THRE is set, writing a single character to the THR clears the THRE. Any additional writes to the THR before the THRE is set again causes the THR data to be overwritten. If FIFO's are enabled (FCR[0] set to one) and THRE is set, x number of characters of data may be written to the THR before the FIFO is full. The number x (default=16) is determined by the value of FIFO Depth that you set during configuration. Any attempt to write data when the FIFO is full results in the write data being lost.</p>	0x0

Table 360: UART\_SRBR\_STHR11\_REG (0x5000105C)

Bit	Mode	Symbol	Description	Reset
15:8	-	-		0x0
7:0	R/W	SRBR_STHRx	<p>Shadow Receive Buffer Register x: This is a shadow register for the RBR and has been allocated sixteen 32-bit locations so as to accommodate burst accesses from the master. This register contains the data byte received on the serial input port (sin) in UART mode or the serial infrared input (sir_in) in infrared mode. The data in this register is valid only if the Data Ready (DR) bit in the Line status Register (LSR) is set. If FIFOs are disabled (FCR[0] set to zero), the data in the RBR must be read before the next data arrives, otherwise it will be overwritten, resulting in</p>	0x0

Bit	Mode	Symbol	Description	Reset
			<p>an overrun error. If FIFOs are enabled (FCR[0] set to one), this register accesses the head of the receive FIFO. If the receive FIFO is full and this register is not read before the next data character arrives, then the data already in the FIFO will be preserved but any incoming data will be lost. An overrun error will also occur. Shadow Transmit Holding Register 0: This is a shadow register for the THR and has been allocated sixteen 32-bit locations so as to accommodate burst accesses from the master. This register contains data to be transmitted on the serial output port (sout) in UART mode or the serial infrared output (sir_out_n) in infrared mode. Data should only be written to the THR when the THR Empty (THRE) bit (LSR[5]) is set. If FIFO's are disabled (FCR[0] set to zero) and THRE is set, writing a single character to the THR clears the THRE. Any additional writes to the THR before the THRE is set again causes the THR data to be overwritten. If FIFO's are enabled (FCR[0] set to one) and THRE is set, x number of characters of data may be written to the THR before the FIFO is full. The number x (default=16) is determined by the value of FIFO Depth that you set during configuration. Any attempt to write data when the FIFO is full results in the write data being lost.</p>	

Table 361: UART\_SRBR\_STHR12\_REG (0x50001060)

Bit	Mode	Symbol	Description	Reset
15:8	-	-		0x0
7:0	R/W	SRBR_STHRx	<p>Shadow Receive Buffer Register x: This is a shadow register for the RBR and has been allocated sixteen 32-bit locations so as to accommodate burst accesses from the master. This register contains the data byte received on the serial input port (sin) in UART mode or the serial infrared input (sir_in) in infrared mode. The data in this register is valid only if the Data Ready (DR) bit in the Line status Register (LSR) is set. If FIFOs are disabled (FCR[0] set to zero), the data in the RBR must be read before the next data arrives, otherwise it will be overwritten, resulting in an overrun error. If FIFOs are enabled (FCR[0] set to one), this register accesses the head of the receive FIFO. If the receive FIFO is full and this register is not read before the next data character arrives, then the data already in the FIFO will be preserved but any incoming data will be lost. An overrun error will also occur. Shadow Transmit Holding Register 0: This is a shadow register for the THR and has been allocated sixteen 32-bit locations so as to accommodate burst accesses from the master. This register contains data to be transmitted on the serial output port (sout) in UART mode or the serial infrared output (sir_out_n) in infrared mode. Data should only be written to the THR when the THR Empty (THRE) bit (LSR[5]) is set. If FIFO's are disabled (FCR[0]</p>	0x0



Bit	Mode	Symbol	Description	Reset
			set to zero) and THRE is set, writing a single character to the THR clears the THRE. Any additional writes to the THR before the THRE is set again causes the THR data to be overwritten. If FIFO's are enabled (FCR[0] set to one) and THRE is set, x number of characters of data may be written to the THR before the FIFO is full. The number x (default=16) is determined by the value of FIFO Depth that you set during configuration. Any attempt to write data when the FIFO is full results in the write data being lost.	

Table 362: UART\_SRBR\_STHR13\_REG (0x50001064)

Bit	Mode	Symbol	Description	Reset
15:8	-	-		0x0
7:0	R/W	SRBR_STHRx	Shadow Receive Buffer Register x: This is a shadow register for the RBR and has been allocated sixteen 32-bit locations so as to accommodate burst accesses from the master. This register contains the data byte received on the serial input port (sin) in UART mode or the serial infrared input (sir_in) in infrared mode. The data in this register is valid only if the Data Ready (DR) bit in the Line status Register (LSR) is set. If FIFOs are disabled (FCR[0] set to zero), the data in the RBR must be read before the next data arrives, otherwise it will be overwritten, resulting in an overrun error. If FIFOs are enabled (FCR[0] set to one), this register accesses the head of the receive FIFO. If the receive FIFO is full and this register is not read before the next data character arrives, then the data already in the FIFO will be preserved but any incoming data will be lost. An overrun error will also occur. Shadow Transmit Holding Register 0: This is a shadow register for the THR and has been allocated sixteen 32-bit locations so as to accommodate burst accesses from the master. This register contains data to be transmitted on the serial output port (sout) in UART mode or the serial infrared output (sir_out_n) in infrared mode. Data should only be written to the THR when the THR Empty (THRE) bit (LSR[5]) is set. If FIFO's are disabled (FCR[0] set to zero) and THRE is set, writing a single character to the THR clears the THRE. Any additional writes to the THR before the THRE is set again causes the THR data to be overwritten. If FIFO's are enabled (FCR[0] set to one) and THRE is set, x number of characters of data may be written to the THR before the FIFO is full. The number x (default=16) is determined by the value of FIFO Depth that you set during configuration. Any attempt to write data when the FIFO is full results in the write data being lost.	0x0



Table 363: UART\_SRBR\_STHR14\_REG (0x50001068)

Bit	Mode	Symbol	Description	Reset
15:8	-	-		0x0
7:0	R/W	SRBR_STHRx	Shadow Receive Buffer Register x: This is a shadow register for the RBR and has been allocated sixteen 32-bit locations so as to accommodate burst accesses from the master. This register contains the data byte received on the serial input port (sin) in UART mode or the serial infrared input (sir_in) in infrared mode. The data in this register is valid only if the Data Ready (DR) bit in the Line status Register (LSR) is set. If FIFOs are disabled (FCR[0] set to zero), the data in the RBR must be read before the next data arrives, otherwise it will be overwritten, resulting in an overrun error. If FIFOs are enabled (FCR[0] set to one), this register accesses the head of the receive FIFO. If the receive FIFO is full and this register is not read before the next data character arrives, then the data already in the FIFO will be preserved but any incoming data will be lost. An overrun error will also occur. Shadow Transmit Holding Register 0: This is a shadow register for the THR and has been allocated sixteen 32-bit locations so as to accommodate burst accesses from the master. This register contains data to be transmitted on the serial output port (sout) in UART mode or the serial infrared output (sir_out_n) in infrared mode. Data should only be written to the THR when the THR Empty (THRE) bit (LSR[5]) is set. If FIFO's are disabled (FCR[0] set to zero) and THRE is set, writing a single character to the THR clears the THRE. Any additional writes to the THR before the THRE is set again causes the THR data to be overwritten. If FIFO's are enabled (FCR[0] set to one) and THRE is set, x number of characters of data may be written to the THR before the FIFO is full. The number x (default=16) is determined by the value of FIFO Depth that you set during configuration. Any attempt to write data when the FIFO is full results in the write data being lost.	0x0

Table 364: UART\_SRBR\_STHR15\_REG (0x5000106C)

Bit	Mode	Symbol	Description	Reset
15:8	-	-		0x0
7:0	R/W	SRBR_STHRx	Shadow Receive Buffer Register x: This is a shadow register for the RBR and has been allocated sixteen 32-bit locations so as to accommodate burst accesses from the master. This register contains the data byte received on the serial input port (sin) in UART mode or the serial infrared input (sir_in) in infrared mode. The data in this register is valid only if the Data Ready (DR) bit in the Line status Register (LSR) is set. If FIFOs are disabled (FCR[0] set to zero), the data in the RBR must be read before the next data arrives, otherwise it will be overwritten, resulting in	0x0

Bit	Mode	Symbol	Description	Reset
			<p>an overrun error. If FIFOs are enabled (FCR[0] set to one), this register accesses the head of the receive FIFO. If the receive FIFO is full and this register is not read before the next data character arrives, then the data already in the FIFO will be preserved but any incoming data will be lost. An overrun error will also occur. Shadow Transmit Holding Register 0: This is a shadow register for the THR and has been allocated sixteen 32-bit locations so as to accommodate burst accesses from the master. This register contains data to be transmitted on the serial output port (sout) in UART mode or the serial infrared output (sir_out_n) in infrared mode. Data should only be written to the THR when the THR Empty (THRE) bit (LSR[5]) is set. If FIFO's are disabled (FCR[0] set to zero) and THRE is set, writing a single character to the THR clears the THRE. Any additional writes to the THR before the THRE is set again causes the THR data to be overwritten. If FIFO's are enabled (FCR[0] set to one) and THRE is set, x number of characters of data may be written to the THR before the FIFO is full. The number x (default=16) is determined by the value of FIFO Depth that you set during configuration. Any attempt to write data when the FIFO is full results in the write data being lost.</p>	

Table 365: **UART\_FAR\_REG (0x50001070)**

Bit	Mode	Symbol	Description	Reset
0	R	UART_FAR	<p>Description: Writes will have no effect when FIFO_ACCESS == No, always readable. This register is use to enable a FIFO access mode for testing, so that the receive FIFO can be written by the master and the transmit FIFO can be read by the master when FIFO's are implemented and enabled. When FIFO's are not implemented or not enabled it allows the RBR to be written by the master and the THR to be read by the master. 0 = FIFO access mode disabled 1 = FIFO access mode enabled Note, that when the FIFO access mode is enabled/disabled, the control portion of the receive FIFO and transmit FIFO is reset and the FIFO's are treated as empty.</p>	0x0

Table 366: **UART\_USR\_REG (0x5000107C)**

Bit	Mode	Symbol	Description	Reset
15:5	-	-		0x0
4	R	UART_RFF	<p>Receive FIFO Full. This is used to indicate that the receive FIFO is completely full. 0 = Receive FIFO not full 1 = Receive FIFO Full</p>	0x0

Bit	Mode	Symbol	Description	Reset
			This bit is cleared when the RX FIFO is no longer full.	
3	R	UART_RFNE	Receive FIFO Not Empty. This is used to indicate that the receive FIFO contains one or more entries. 0 = Receive FIFO is empty 1 = Receive FIFO is not empty This bit is cleared when the RX FIFO is empty.	0x0
2	R	UART_TFE	Transmit FIFO Empty. This is used to indicate that the transmit FIFO is completely empty. 0 = Transmit FIFO is not empty 1 = Transmit FIFO is empty This bit is cleared when the TX FIFO is no longer empty.	0x1
1	R	UART_TFNF	Transmit FIFO Not Full. This is used to indicate that the transmit FIFO is not full. 0 = Transmit FIFO is full 1 = Transmit FIFO is not full This bit is cleared when the TX FIFO is full.	0x1
0	R	UART_BUSY	UART Busy. This indicates that a serial transfer is in progress, when cleared indicates that the DW_apb_uart is idle or inactive. 0 - DW_apb_uart is idle or inactive 1 - DW_apb_uart is busy (actively transferring data) Note that it is possible for the UART Busy bit to be cleared even though a new character may have been sent from another device. That is, if the DW_apb_uart has no data in the THR and RBR and there is no transmission in progress and a start bit of a new character has just reached the DW_apb_uart. This is due to the fact that a valid start is not seen until the middle of the bit period and this duration is dependent on the baud divisor that has been programmed. If a second system clock has been implemented (CLOCK_MODE == Enabled) the assertion of this bit will also be delayed by several cycles of the slower clock.	0x0

Table 367: UART\_TFL\_REG (0x50001080)

Bit	Mode	Symbol	Description	Reset
4:0	R	UART_TRANSMIT_FIFO_LEVEL	Transmit FIFO Level. This indicates the number of data entries in the transmit FIFO.	0x0

Table 368: UART\_RFL\_REG (0x50001084)

Bit	Mode	Symbol	Description	Reset
4:0	R	UART_RECEIVE_FIFO_LEVEL	Receive FIFO Level. This indicates the number of data entries in the receive FIFO.	0x0

Table 369: UART\_SRR\_REG (0x50001088)

Bit	Mode	Symbol	Description	Reset
15:3	-	-		0x0
2	W	UART_XFR	XMIT FIFO Reset. This is a shadow register for the XMIT FIFO Reset bit (FCR[2]). This can be used to remove the burden on software having to store previously written FCR values (which are pretty static) just to reset the transmit FIFO. This resets the control portion of the transmit FIFO and treats the FIFO as empty. Note that this bit is 'self-clearing'. It is not necessary to clear this bit.	0x0
1	W	UART_RFR	RCVR FIFO Reset. This is a shadow register for the RCVR FIFO Reset bit (FCR[1]). This can be used to remove the burden on software having to store previously written FCR values (which are pretty static) just to reset the receive FIFO. This resets the control portion of the receive FIFO and treats the FIFO as empty. Note that this bit is 'self-clearing'. It is not necessary to clear this bit.	0x0
0	W	UART_UR	UART Reset. This asynchronously resets the UART Ctrl and synchronously removes the reset assertion. For a two clock implementation both pclk and sclk domains are reset.	0x0

Table 370: UART\_SRTS\_REG (0x5000108C)

Bit	Mode	Symbol	Description	Reset
15:1	-	-		0x0
0	R/W	UART_SHADOW_REQUEST_TO_SEND	Shadow Request to Send. This is a shadow register for the RTS bit (MCR[1]), this can be used to remove the burden of having to performing a read-modify-write on the MCR. This is used to directly control the Request to Send (rts_n) output. The Request To Send (rts_n) output is used to inform the modem or data set that the UART Ctrl is ready to exchange data. When Auto RTS Flow Control is not enabled (MCR[5] = 0), the rts_n signal is set low by programming MCR[1] (RTS) to a high. In Auto Flow Control, AFCE_MODE == Enabled and active (MCR[5] = 1) and FIFOs enable (FCR[0] = 1), the rts_n output is controlled in the	0x0

Bit	Mode	Symbol	Description	Reset
			<p>same way, but is also gated with the receiver FIFO threshold trigger (rts_n is inactive high when above the threshold).</p> <p>Note that in Loopback mode (MCR[4] = 1), the rts_n output is held inactive-high while the value of this location is internally looped back to an input.</p>	

Table 371: UART\_SBCR\_REG (0x50001090)

Bit	Mode	Symbol	Description	Reset
15:1	-	-		0x0
0	R/W	UART_SHADOW_BREAK_CONTROL	<p>Shadow Break Control Bit.</p> <p>This is a shadow register for the Break bit (LCR[6]), this can be used to remove the burden of having to performing a read modify write on the LCR. This is used to cause a break condition to be transmitted to the receiving device.</p> <p>If set to one the serial output is forced to the spacing (logic 0) state. When not in Loopback Mode, as determined by MCR[4], the sout line is forced low until the Break bit is cleared.</p> <p>If SIR_MODE active (MCR[6] = 1) the sir_out_n line is continuously pulsed. When in Loopback Mode, the break condition is internally looped back to the receiver.</p>	0x0

Table 372: UART\_SDMAM\_REG (0x50001094)

Bit	Mode	Symbol	Description	Reset
15:1	-	-		0x0
0	R/W	UART_SHADOW_DMA_MODE	<p>Shadow DMA Mode.</p> <p>This is a shadow register for the DMA mode bit (FCR[3]). This can be used to remove the burden of having to store the previously written value to the FCR in memory and having to mask this value so that only the DMA Mode bit gets updated. This determines the DMA signalling mode used for the dma_tx_req_n and dma_rx_req_n output signals.</p> <p>0 = mode 0 1 = mode 1</p>	0x0

Table 373: UART\_SFE\_REG (0x50001098)

Bit	Mode	Symbol	Description	Reset
15:1	-	-		0x0
0	R/W	UART_SHADOW_FIFO_ENABLE	<p>Shadow FIFO Enable.</p> <p>This is a shadow register for the FIFO enable bit (FCR[0]). This can be used to remove the burden of having to store the previously written value to the FCR in memory and having to mask this value</p>	0x0

Bit	Mode	Symbol	Description	Reset
			so that only the FIFO enable bit gets updated. This enables/disables the transmit (XMIT) and receive (RCVR) FIFOs. If this bit is set to zero (disabled) after being enabled then both the XMIT and RCVR controller portion of FIFOs are reset.	

Table 374: UART\_SRT\_REG (0x5000109C)

Bit	Mode	Symbol	Description	Reset
15:2	-	-		0x0
1:0	R/W	UART_SHADOW_RCVR_TRIGGER	<p>Shadow RCVR Trigger.</p> <p>This is a shadow register for the RCVR trigger bits (FCR[7:6]). This can be used to remove the burden of having to store the previously written value to the FCR in memory and having to mask this value so that only the RCVR trigger bit gets updated.</p> <p>This is used to select the trigger level in the receiver FIFO at which the Received Data Available Interrupt is generated. It also determines when the dma_rx_req_n signal is asserted when DMA Mode (FCR[3]) = 1. The following trigger levels are supported:</p> <p>00 = 1 character in the FIFO            01 = FIFO ¼ full            10 = FIFO ½ full            11 = FIFO 2 less than full</p>	0x0

Table 375: UART\_STET\_REG (0x500010A0)

Bit	Mode	Symbol	Description	Reset
15:2	-	-		0x0
1:0	R/W	UART_SHADOW_TX_EMPTY_TRIGGER	<p>Shadow TX Empty Trigger.</p> <p>This is a shadow register for the TX empty trigger bits (FCR[5:4]). This can be used to remove the burden of having to store the previously written value to the FCR in memory and having to mask this value so that only the TX empty trigger bit gets updated.</p> <p>This is used to select the empty threshold level at which the THRE Interrupts are generated when the mode is active. The following trigger levels are supported:</p> <p>00 = FIFO empty            01 = 2 characters in the FIFO            10 = FIFO ¼ full            11 = FIFO ½ full</p>	0x0

Table 376: **UART\_HTX\_REG (0x500010A4)**

Bit	Mode	Symbol	Description	Reset
15:1	-	-		0x0
0	R/W	UART_HALT_TX	<p>This register is use to halt transmissions for testing, so that the transmit FIFO can be filled by the master when FIFOs are implemented and enabled.</p> <p>0 = Halt TX disabled 1 = Halt TX enabled</p> <p>Note, if FIFOs are implemented and not enabled, the setting of the halt TX register has no effect on operation.</p>	0x0

Table 377: **UART\_DMASA\_REG (0x500010A8)**

Bit	Mode	Symbol	Description	Reset
0	W	DMASA	<p>This register is use to perform DMA software acknowledge if a transfer needs to be terminated due to an error condition. For example, if the DMA disables the channel, then the DW_apb_uart should clear its request. This will cause the TX request, TX single, RX request and RX single signals to de-assert. Note that this bit is 'self-clearing' and it is not necessary to clear this bit.</p>	0x0

Table 378: **UART\_DLF\_REG (0x500010C0)**

Bit	Mode	Symbol	Description	Reset
3:0	R/W	UART_DLF	The fractional value is added to integer value set by DLH, DLL. Fractional value is equal UART_DLF/16	0x0

Table 379: **UART\_UCV\_REG (0x500010F8)**

Bit	Mode	Symbol	Description	Reset
15:0	R	UCV	Component Version	0x352A

Table 380: **UART\_UCV\_HIGH\_REG (0x500010FA)**

Bit	Mode	Symbol	Description	Reset
15:0	R	UCV	Component Version	0x3331

Table 381: **UART\_CTR\_REG (0x500010FC)**

Bit	Mode	Symbol	Description	Reset
15:0	R	CTR	Component Type Register	0x110

Table 382: UART\_CTR\_HIGH\_REG (0x500010FE)

Bit	Mode	Symbol	Description	Reset
15:0	R	CTR	Component Type Register	0x4457

Table 383: UART2\_RBR\_THR\_DLL\_REG (0x50001100)

Bit	Mode	Symbol	Description	Reset
15:8	-	-		0x0
7:0	R/W	RBR_THR_DLL	<p><b>Receive Buffer Register: (RBR).</b> This register contains the data byte received on the serial input port (sin) in UART mode. The data in this register is valid only if the Data Ready (DR) bit in the Line status Register (LSR) is set. If FIFOs are disabled (FCR[0] set to zero), the data in the RBR must be read before the next data arrives, otherwise it will be overwritten, resulting in an overrun error. If FIFOs are enabled (FCR[0] set to one), this register accesses the head of the receive FIFO. If the receive FIFO is full and this register is not read before the next data character arrives, then the data already in the FIFO will be preserved but any incoming data will be lost. An overrun error will also occur.</p> <p><b>Transmit Holding Register: (THR)</b> This register contains data to be transmitted on the serial output port (sout) in UART mode. Data should only be written to the THR when the THR Empty (THRE) bit (LSR[5]) is set. If FIFO's are disabled (FCR[0] set to zero) and THRE is set, writing a single character to the THR clears the THRE. Any additional writes to the THR before the THRE is set again causes the THR data to be overwritten. If FIFO's are enabled (FCR[0] set to one) and THRE is set, 16 number of characters of data may be written to the THR before the FIFO is full. Any attempt to write data when the FIFO is full results in the write data being lost.</p> <p><b>Divisor Latch (Low): (DLL)</b> This register makes up the lower 8-bits of a 16-bit, read/write, Divisor Latch register that contains the baud rate divisor for the UART. This register may only be accessed when the DLAB bit (LCR[7]) is set. The output baud rate is equal to the serial clock (sclk) frequency divided by sixteen times the value of the baud rate divisor, as follows:  <math display="block">\text{baud rate} = (\text{serial clock freq}) / (16 * \text{divisor})</math> Note that with the Divisor Latch Registers (DLL and DLH) set to zero, the baud clock is disabled and no serial communications will occur. Also, once the Divisor Latch is set, at least 8 clock cycles of the slowest UART clock should be allowed to pass before transmitting or receiving data.  For the Divisor Latch (High) bits, see register UART_IER_DLH_REG.</p>	0x0



Table 384: UART2\_IER\_DLH\_REG (0x50001104)

Bit	Mode	Symbol	Description	Reset
15:8	-	-		0x0
7	R/W	PTIME_dlh7	<p><b>Interrupt Enable Register: PTIME</b>, Programmable THRE Interrupt Mode Enable. This is used to enable/disable the generation of THRE Interrupt. 0 = disabled 1 = enabled.</p> <p><b>Divisor Latch (High): DLH7</b>, Bit 7 of the upper part of a 16-bit, read/write, Divisor Latch register that contains the baud rate divisor for the UART. This register may be accessed only when the DLAB bit (LCR[7]) is set. See register UART_RBR_THR_DLL_REG.</p>	0x0
6:4	R/W	dlh6_4	<p><b>Divisor Latch (High): DLH6 to DLH4</b>, Bits 6 to 4 of the upper part of a 16-bit, read/write, Divisor Latch register that contains the baud rate divisor for the UART. This register may be accessed only when the DLAB bit (LCR[7]) is set, otherwise, this field is reserved. See register UART_RBR_THR_DLL_REG.</p>	0x0
3	R/W	EDSSI_dlh3	<p><b>Interrupt Enable Register: EDSSI</b>, Enable Modem Status Interrupt. This is used to enable/disable the generation of Modem Status Interrupt. This is the fourth highest priority interrupt. 0 = disabled 1 = enabled</p> <p><b>Divisor Latch (High): DLH3</b>, Bit 3 of the upper part of a 16-bit, read/write, Divisor Latch register that contains the baud rate divisor for the UART. This register may be accessed only when the DLAB bit (LCR[7]) is set. See register UART_RBR_THR_DLL_REG.</p>	0x0
2	R/W	ELSI_dlh2	<p><b>Interrupt Enable Register: ELSI</b>, Enable Receiver Line Status Interrupt. This is used to enable/disable the generation of Receiver Line Status Interrupt. This is the highest priority interrupt. 0 = disabled 1 = enabled</p> <p><b>Divisor Latch (High): DLH2</b>, Bit 2 of the upper part of a 16-bit, read/write, Divisor Latch register that contains the baud rate divisor for the UART. This register may be accessed only when the DLAB bit (LCR[7]) is set. See register UART_RBR_THR_DLL_REG.</p>	0x0
1	R/W	ETBEI_dlh1	<p><b>Interrupt Enable Register: ETBEI</b>, Enable Transmit Holding Register Empty Interrupt. This is used to enable/disable the generation of Transmitter Holding Register Empty Interrupt. This is the third highest priority interrupt. 0 = disabled 1 = enabled</p> <p><b>Divisor Latch (High): DLH1</b>, Bit 1 of the upper part of a 16-bit, read/write, Divisor Latch register that contains the baud rate divisor for the UART. This register may be accessed only when the DLAB bit (LCR[7]) is set. See register UART_RBR_THR_DLL_REG.</p>	0x0
0	R/W	ERBFI_dlh0	<p><b>Interrupt Enable Register: ERBFI</b>, Enable Received Data Available Interrupt. This is used to</p>	0x0

Bit	Mode	Symbol	Description	Reset
			<p>enable/disable the generation of Received Data Available Interrupt and the Character Timeout Interrupt (if in FIFO mode and FIFO's enabled). These are the second highest priority interrupts. 0 = disabled 1 = enabled</p> <p><b>Divisor Latch (High): DLH0</b>, Bit 0 of the upper part of a 16-bit, read/write, Divisor Latch register that contains the baud rate divisor for the UART. This register may be accessed only when the DLAB bit (LCR[7]) is set. See register UART_RBR_THR_DLL_REG.</p>	

Table 385: UART2\_IIR\_FCR\_REG (0x50001108)

Bit	Mode	Symbol	Description	Reset
7:6	R/W	UART_FIFOSE_RT	<p>On read</p> <p>FIFO's Enabled (or FIFOSE): This is used to indicate whether the FIFO's are enabled or disabled. 00 = disabled. 11 = enabled.</p> <p>On write</p> <p>RCVR Trigger (or RT):. This is used to select the trigger level in the receiver FIFO at which the Received Data Available Interrupt will be generated. In auto flow control mode it is used to determine when the rts_n signal will be de-asserted. It also determines when the dma_rx_req_n signal will be asserted when in certain modes of operation. The following trigger levels are supported: 00 = 1 character in the FIFO 01 = FIFO 1/4 full 10 = FIFO 1/2 full 11 = FIFO 2 less than full</p>	0x0
5:4	R0/W	UART_TET	<p>On read</p> <p>reserved</p> <p>On Write</p> <p>TX Empty Trigger (or TET): This is used to select the empty threshold level at which the THRE Interrupts will be generated when the mode is active. It also determines when the dma_tx_req_n signal will be asserted when in certain modes of operation. The following trigger levels are supported: 00 = FIFO empty 01 = 2 characters in the FIFO 10 = FIFO 1/4 full 11 = FIFO 1/2 full</p>	0x0
3	R/W	UART_IID3_DMAM	<p>On Read (Bit3)</p> <p>Interrupt ID (or IID): This indicates the highest priority pending interrupt which can be one of the following types:</p> <p>0001 = no interrupt pending.</p> <p>0010 = THR empty.</p> <p>0100 = received data available.</p> <p>0110 = receiver line status.</p> <p>0111 = busy detect.</p> <p>1100 = character timeout.</p> <p>On Write</p> <p>DMA Mode (or DMAM): This determines the DMA signalling mode used for the dma_tx_req_n and</p>	0x0

Bit	Mode	Symbol	Description	Reset
			dma_rx_req_n output signals. 0 = mode 0 1 = mode 1	
2	R/W	UART_IID2_XFIFOR	<p>On Read (Bit2)</p> <p>Interrupt ID (or IID): This indicates the highest priority pending interrupt which can be one of the following types:</p> <p>0001 = no interrupt pending.  0010 = THR empty.  0100 = received data available.  0110 = receiver line status.  0111 = busy detect.  1100 = character timeout.</p> <p>On Write</p> <p>XMIT FIFO Reset (or XFIFOR): This resets the control portion of the transmit FIFO and treats the FIFO as empty. Note that this bit is 'self-clearing' and it is not necessary to clear this bit.</p>	0x0
1	R/W	UART_IID1_RFIFORE	<p>On Read (Bit1)</p> <p>Interrupt ID (or IID): This indicates the highest priority pending interrupt which can be one of the following types:</p> <p>0001 = no interrupt pending.  0010 = THR empty.  0100 = received data available.  0110 = receiver line status.  0111 = busy detect.  1100 = character timeout.</p> <p>On Write</p> <p>RCVR FIFO Reset (or RFIFOR): This resets the control portion of the receive FIFO and treats the FIFO as empty. Note that this bit is 'self-clearing' and it is not necessary to clear this bit.</p>	0x0
0	R/W	UART_IID0_FIFOE	<p>On Read (Bit0)</p> <p>Interrupt ID (or IID): This indicates the highest priority pending interrupt which can be one of the following types:</p> <p>0001 = no interrupt pending.  0010 = THR empty.  0100 = received data available.  0110 = receiver line status.  0111 = busy detect.  1100 = character timeout.</p> <p>On Write</p> <p>FIFO Enable (or FIFOE): This enables/disables the transmit (XMIT) and receive (RCVR) FIFO's. Whenever the value of this bit is changed both the XMIT and RCVR controller portion of FIFO's will be reset</p>	0x1

Table 386: UART2\_LCR\_REG (0x5000110C)

Bit	Mode	Symbol	Description	Reset
15:8	-	-		0x0
7	R/W	UART_DLAB	<p>Divisor Latch Access Bit. Writeable only when UART is not busy (USR[0] is zero).</p> <p>This bit is used to enable reading and writing of the Divisor Latch register (DLL and DLH) to set the baud rate of the UART.</p> <p>This bit must be cleared after initial baud rate setup in order to access other registers.</p>	0x0
6	R/W	UART_BC	<p>Break Control Bit.</p> <p>This is used to cause a break condition to be transmitted to the receiving device. If set to one the serial output is forced to the spacing (logic 0) state. When not in Loopback Mode, as determined by MCR[4], the serial line is forced low until the Break bit is cleared. If active (MCR[6] set to one) the serial line is continuously pulsed. When in Loopback Mode, the break condition is internally looped back to the receiver and the serial line is forced low.</p>	0x0
5	-	-		0x0
4	R/W	UART_EPS	<p>Even Parity Select. Writeable only when UART is not busy (USR[0] is zero).</p> <p>This is used to select between even and odd parity, when parity is enabled (PEN set to one). If set to one, an even number of logic 1s is transmitted or checked. If set to zero, an odd number of logic 1s is transmitted or checked.</p>	0x0
3	R/W	UART_PEN	<p>Parity Enable. Writeable only when UART is not busy (USR[0] is zero)</p> <p>This bit is used to enable and disable parity generation and detection in transmitted and received serial character respectively.</p> <p>0 = parity disabled 1 = parity enabled</p>	0x0
2	R/W	UART_STOP	<p>Number of stop bits. Writeable only when UART is not busy (USR[0] is zero).</p> <p>This is used to select the number of stop bits per character that the peripheral transmits and receives. If set to zero, one stop bit is transmitted in the serial data.</p> <p>If set to one and the data bits are set to 5 (LCR[1:0] set to zero) one and a half stop bits is transmitted. Otherwise, two stop bits are transmitted. Note that regardless of the number of stop bits selected, the receiver checks only the first stop bit.</p> <p>0 = 1 stop bit 1 = 1.5 stop bits when DLS (LCR[1:0]) is zero, else 2 stop bit</p>	0x0
1:0	R/W	UART_DLS	<p>Data Length Select. Writeable only when UART is not busy (USR[0] is zero).</p> <p>This is used to select the number of data bits per character that the peripheral transmits and</p>	0x0

Bit	Mode	Symbol	Description	Reset
			receives. The number of bit that may be selected areas follows: 00 = 5 bits 01 = 6 bits 10 = 7 bits 11 = 8 bits	

Table 387: **UART2\_MCR\_REG (0x50001110)**

Bit	Mode	Symbol	Description	Reset
15:5	-	-		0x0
4	R/W	UART_LB	LoopBack Bit. This is used to put the UART into a diagnostic mode for test purposes. If operating in UART mode (SIR_MODE not active, MCR[6] set to zero), data on the sout line is held high, while serial data output is looped back to the sin line, internally. In this mode all the interrupts are fully functional. Also, in loopback mode, the modem control inputs (dsr_n, cts_n, ri_n, dcd_n) are disconnected and the modem control outputs (dtr_n, rts_n, out1_n, out2_n) are looped back to the inputs, internally. If operating in infrared mode (SIR_MODE active, MCR[6] set to one), data on the sir_out_n line is held low, while serial data output is inverted and looped back to the sir_in line.	0x0
3:0	-	-		0x0

Table 388: **UART2\_LSR\_REG (0x50001114)**

Bit	Mode	Symbol	Description	Reset
15:8	-	-		0x0
7	R	UART_RFE	Receiver FIFO Error bit. This bit is only relevant when FIFOs are enabled (FCR[0] set to one). This is used to indicate if there is at least one parity error, framing error, or break indication in the FIFO. 0 = no error in RX FIFO 1 = error in RX FIFO This bit is cleared when the LSR is read and the character with the error is at the top of the receiver FIFO and there are no subsequent errors in the FIFO.	0x0
6	R	UART_TEMT	Transmitter Empty bit. If FIFOs enabled (FCR[0] set to one), this bit is set whenever the Transmitter Shift Register and the FIFO are both empty. If FIFOs are disabled, this bit is set whenever the Transmitter Holding Register(THR) and the Transmitter Shift Register are both empty.	0x1

Bit	Mode	Symbol	Description	Reset
5	R	UART_THRE	<p>Transmit Holding Register Empty bit.</p> <p>If THRE mode is disabled (IER[7] set to zero) and regardless of FIFO's being implemented/enabled or not, this bit indicates that the THR or TX FIFO is empty.</p> <p>This bit is set whenever data is transferred from the THR or TX FIFO to the transmitter shift register and no new data has been written to the THR or TX FIFO. This also causes a THRE Interrupt to occur, if the THRE Interrupt is enabled. If both modes are active (IER[7] set to one and FCR[0] set to one respectively), the functionality is switched to indicate the transmitter FIFO is full, and no longer controls THRE interrupts, which are then controlled by the FCR[5:4] threshold setting.</p>	0x1
4	R	UART_BI	<p>Break Interrupt bit.</p> <p>This is used to indicate the detection of a break sequence on the serial input data.</p> <p>If in UART mode (SIR_MODE == Disabled), it is set whenever the serial input, sin, is held in a logic '0' state for longer than the sum of start time + data bits + parity + stop bits.</p> <p>If in infrared mode (SIR_MODE == Enabled), it is set whenever the serial input, sir_in, is continuously pulsed to logic '0' for longer than the sum of start time + data bits + parity + stop bits. A break condition on serial input causes one and only one character, consisting of all zeros, to be received by the UART.</p> <p>In the FIFO mode, the character associated with the break condition is carried through the FIFO and is revealed when the character is at the top of the FIFO.</p> <p>Reading the LSR clears the BI bit. In the non-FIFO mode, the BI indication occurs immediately and persists until the LSR is read.</p>	0x0
3	R	UART_FE	<p>Framing Error bit.</p> <p>This is used to indicate the occurrence of a framing error in the receiver. A framing error occurs when the receiver does not detect a valid STOP bit in the received data.</p> <p>In the FIFO mode, since the framing error is associated with a character received, it is revealed when the character with the framing error is at the top of the FIFO.</p> <p>When a framing error occurs, the UART tries to resynchronize. It does this by assuming that the error was due to the start bit of the next character and then continues receiving the other bit i.e. data, and/or parity and stop. It should be noted that the Framing Error (FE) bit (LSR[3]) is set if a break interrupt has occurred, as indicated by Break Interrupt (BI) bit (LSR[4]).</p> <p>0 = no framing error 1 = framing error</p> <p>Reading the LSR clears the FE bit.</p>	0x0
2	R	UART_PE	Parity Error bit.	0x0

Bit	Mode	Symbol	Description	Reset
			<p>This is used to indicate the occurrence of a parity error in the receiver if the Parity Enable (PEN) bit (LCR[3]) is set.</p> <p>In the FIFO mode, since the parity error is associated with a character received, it is revealed when the character with the parity error arrives at the top of the FIFO.</p> <p>It should be noted that the Parity Error (PE) bit (LSR[2]) is set if a break interrupt has occurred, as indicated by Break Interrupt (BI) bit (LSR[4]).</p> <p>0 = no parity error 1 = parity error</p> <p>Reading the LSR clears the PE bit.</p>	
1	R	UART_OE	<p>Overrun error bit.</p> <p>This is used to indicate the occurrence of an overrun error.</p> <p>This occurs if a new data character was received before the previous data was read.</p> <p>In the non-FIFO mode, the OE bit is set when a new character arrives in the receiver before the previous character was read from the RBR. When this happens, the data in the RBR is overwritten.</p> <p>In the FIFO mode, an overrun error occurs when the FIFO is full and a new character arrives at the receiver. The data in the FIFO is retained and the data in the receive shift register is lost.</p> <p>0 = no overrun error 1 = overrun error</p> <p>Reading the LSR clears the OE bit.</p>	0x0
0	R	UART_DR	<p>Data Ready bit.</p> <p>This is used to indicate that the receiver contains at least one character in the RBR or the receiver FIFO.</p> <p>0 = no data ready 1 = data ready</p> <p>This bit is cleared when the RBR is read in non-FIFO mode, or when the receiver FIFO is empty, in FIFO mode.</p>	0x0

Table 389: **UART2\_SCR\_REG (0x5000111C)**

Bit	Mode	Symbol	Description	Reset
15:8	-	-		0x0
7:0	R/W	UART_SCRATCH_PAD	This register is for programmers to use as a temporary storage space. It has no defined purpose in the UART Ctrl.	0x0

Table 390: **UART2\_SRBR\_STHR0\_REG (0x50001130)**

Bit	Mode	Symbol	Description	Reset
15:8	-	-		0x0

Bit	Mode	Symbol	Description	Reset
7:0	R/W	SRBR_STHRx	<p>Shadow Receive Buffer Register x: This is a shadow register for the RBR and has been allocated sixteen 32-bit locations so as to accommodate burst accesses from the master. This register contains the data byte received on the serial input port (sin) in UART mode or the serial infrared input (sir_in) in infrared mode. The data in this register is valid only if the Data Ready (DR) bit in the Line status Register (LSR) is set. If FIFOs are disabled (FCR[0] set to zero), the data in the RBR must be read before the next data arrives, otherwise it will be overwritten, resulting in an overrun error. If FIFOs are enabled (FCR[0] set to one), this register accesses the head of the receive FIFO. If the receive FIFO is full and this register is not read before the next data character arrives, then the data already in the FIFO will be preserved but any incoming data will be lost. An overrun error will also occur.</p> <p>Shadow Transmit Holding Register 0: This is a shadow register for the THR and has been allocated sixteen 32-bit locations so as to accommodate burst accesses from the master. This register contains data to be transmitted on the serial output port (sout) in UART mode or the serial infrared output (sir_out_n) in infrared mode. Data should only be written to the THR when the THR Empty (THRE) bit (LSR[5]) is set. If FIFO's are disabled (FCR[0] set to zero) and THRE is set, writing a single character to the THR clears the THRE. Any additional writes to the THR before the THRE is set again causes the THR data to be overwritten. If FIFO's are enabled (FCR[0] set to one) and THRE is set, x number of characters of data may be written to the THR before the FIFO is full. The number x (default=16) is determined by the value of FIFO Depth that you set during configuration. Any attempt to write data when the FIFO is full results in the write data being lost.</p>	0x0

Table 391: UART2\_SRBR\_STHR1\_REG (0x50001134)

Bit	Mode	Symbol	Description	Reset
15:8	-	-		0x0
7:0	R/W	SRBR_STHRx	<p>Shadow Receive Buffer Register x: This is a shadow register for the RBR and has been allocated sixteen 32-bit locations so as to accommodate burst accesses from the master. This register contains the data byte received on the serial input port (sin) in UART mode or the serial infrared input (sir_in) in infrared mode. The data in this register is valid only if the Data Ready (DR) bit in the Line status Register (LSR) is set. If FIFOs are disabled (FCR[0] set to zero), the data in the RBR must be read before the next data arrives, otherwise it will be overwritten, resulting in an overrun error. If FIFOs are enabled (FCR[0] set to one), this register accesses the head of the receive FIFO. If the receive FIFO is full and this register is not read before the next data character</p>	0x0



Bit	Mode	Symbol	Description	Reset
			<p>arrives, then the data already in the FIFO will be preserved but any incoming data will be lost. An overrun error will also occur. Shadow Transmit Holding Register 0: This is a shadow register for the THR and has been allocated sixteen 32-bit locations so as to accommodate burst accesses from the master. This register contains data to be transmitted on the serial output port (sout) in UART mode or the serial infrared output (sir_out_n) in infrared mode. Data should only be written to the THR when the THR Empty (THRE) bit (LSR[5]) is set. If FIFO's are disabled (FCR[0] set to zero) and THRE is set, writing a single character to the THR clears the THRE. Any additional writes to the THR before the THRE is set again causes the THR data to be overwritten. If FIFO's are enabled (FCR[0] set to one) and THRE is set, x number of characters of data may be written to the THR before the FIFO is full. The number x (default=16) is determined by the value of FIFO Depth that you set during configuration. Any attempt to write data when the FIFO is full results in the write data being lost.</p>	

Table 392: UART2\_SRBR\_STHR2\_REG (0x50001138)

Bit	Mode	Symbol	Description	Reset
15:8	-	-		0x0
7:0	R/W	SRBR_STHRx	<p>Shadow Receive Buffer Register x: This is a shadow register for the RBR and has been allocated sixteen 32-bit locations so as to accommodate burst accesses from the master. This register contains the data byte received on the serial input port (sin) in UART mode or the serial infrared input (sir_in) in infrared mode. The data in this register is valid only if the Data Ready (DR) bit in the Line status Register (LSR) is set. If FIFOs are disabled (FCR[0] set to zero), the data in the RBR must be read before the next data arrives, otherwise it will be overwritten, resulting in an overrun error. If FIFOs are enabled (FCR[0] set to one), this register accesses the head of the receive FIFO. If the receive FIFO is full and this register is not read before the next data character arrives, then the data already in the FIFO will be preserved but any incoming data will be lost. An overrun error will also occur. Shadow Transmit Holding Register 0: This is a shadow register for the THR and has been allocated sixteen 32-bit locations so as to accommodate burst accesses from the master. This register contains data to be transmitted on the serial output port (sout) in UART mode or the serial infrared output (sir_out_n) in infrared mode. Data should only be written to the THR when the THR Empty (THRE) bit (LSR[5]) is set. If FIFO's are disabled (FCR[0] set to zero) and THRE is set, writing a single character to the THR clears the THRE. Any additional writes to the THR before the THRE is set again causes the THR data to be overwritten.</p>	0x0

Bit	Mode	Symbol	Description	Reset
			If FIFO's are enabled (FCR[0] set to one) and THRE is set, x number of characters of data may be written to the THR before the FIFO is full. The number x (default=16) is determined by the value of FIFO Depth that you set during configuration. Any attempt to write data when the FIFO is full results in the write data being lost.	

Table 393: **UART2\_SRBR\_STHR3\_REG (0x5000113C)**

Bit	Mode	Symbol	Description	Reset
15:8	-	-		0x0
7:0	R/W	SRBR_STHRx	Shadow Receive Buffer Register x: This is a shadow register for the RBR and has been allocated sixteen 32-bit locations so as to accommodate burst accesses from the master. This register contains the data byte received on the serial input port (sin) in UART mode or the serial infrared input (sir_in) in infrared mode. The data in this register is valid only if the Data Ready (DR) bit in the Line status Register (LSR) is set. If FIFOs are disabled (FCR[0] set to zero), the data in the RBR must be read before the next data arrives, otherwise it will be overwritten, resulting in an overrun error. If FIFOs are enabled (FCR[0] set to one), this register accesses the head of the receive FIFO. If the receive FIFO is full and this register is not read before the next data character arrives, then the data already in the FIFO will be preserved but any incoming data will be lost. An overrun error will also occur. Shadow Transmit Holding Register 0: This is a shadow register for the THR and has been allocated sixteen 32-bit locations so as to accommodate burst accesses from the master. This register contains data to be transmitted on the serial output port (sout) in UART mode or the serial infrared output (sir_out_n) in infrared mode. Data should only be written to the THR when the THR Empty (THRE) bit (LSR[5]) is set. If FIFO's are disabled (FCR[0] set to zero) and THRE is set, writing a single character to the THR clears the THRE. Any additional writes to the THR before the THRE is set again causes the THR data to be overwritten. If FIFO's are enabled (FCR[0] set to one) and THRE is set, x number of characters of data may be written to the THR before the FIFO is full. The number x (default=16) is determined by the value of FIFO Depth that you set during configuration. Any attempt to write data when the FIFO is full results in the write data being lost.	0x0

Table 394: **UART2\_SRBR\_STHR4\_REG (0x50001140)**

Bit	Mode	Symbol	Description	Reset
15:8	-	-		0x0

Bit	Mode	Symbol	Description	Reset
7:0	R/W	SRBR_STHRx	<p>Shadow Receive Buffer Register x: This is a shadow register for the RBR and has been allocated sixteen 32-bit locations so as to accommodate burst accesses from the master. This register contains the data byte received on the serial input port (sin) in UART mode or the serial infrared input (sir_in) in infrared mode. The data in this register is valid only if the Data Ready (DR) bit in the Line status Register (LSR) is set. If FIFOs are disabled (FCR[0] set to zero), the data in the RBR must be read before the next data arrives, otherwise it will be overwritten, resulting in an overrun error. If FIFOs are enabled (FCR[0] set to one), this register accesses the head of the receive FIFO. If the receive FIFO is full and this register is not read before the next data character arrives, then the data already in the FIFO will be preserved but any incoming data will be lost. An overrun error will also occur.</p> <p>Shadow Transmit Holding Register 0: This is a shadow register for the THR and has been allocated sixteen 32-bit locations so as to accommodate burst accesses from the master. This register contains data to be transmitted on the serial output port (sout) in UART mode or the serial infrared output (sir_out_n) in infrared mode. Data should only be written to the THR when the THR Empty (THRE) bit (LSR[5]) is set. If FIFO's are disabled (FCR[0] set to zero) and THRE is set, writing a single character to the THR clears the THRE. Any additional writes to the THR before the THRE is set again causes the THR data to be overwritten. If FIFO's are enabled (FCR[0] set to one) and THRE is set, x number of characters of data may be written to the THR before the FIFO is full. The number x (default=16) is determined by the value of FIFO Depth that you set during configuration. Any attempt to write data when the FIFO is full results in the write data being lost.</p>	0x0

Table 395: UART2\_SRBR\_STHR5\_REG (0x50001144)

Bit	Mode	Symbol	Description	Reset
15:8	-	-		0x0
7:0	R/W	SRBR_STHRx	<p>Shadow Receive Buffer Register x: This is a shadow register for the RBR and has been allocated sixteen 32-bit locations so as to accommodate burst accesses from the master. This register contains the data byte received on the serial input port (sin) in UART mode or the serial infrared input (sir_in) in infrared mode. The data in this register is valid only if the Data Ready (DR) bit in the Line status Register (LSR) is set. If FIFOs are disabled (FCR[0] set to zero), the data in the RBR must be read before the next data arrives, otherwise it will be overwritten, resulting in an overrun error. If FIFOs are enabled (FCR[0] set to one), this register accesses the head of the receive FIFO. If the receive FIFO is full and this register is not read before the next data character</p>	0x0

Bit	Mode	Symbol	Description	Reset
			<p>arrives, then the data already in the FIFO will be preserved but any incoming data will be lost. An overrun error will also occur. Shadow Transmit Holding Register 0: This is a shadow register for the THR and has been allocated sixteen 32-bit locations so as to accommodate burst accesses from the master. This register contains data to be transmitted on the serial output port (sout) in UART mode or the serial infrared output (sir_out_n) in infrared mode. Data should only be written to the THR when the THR Empty (THRE) bit (LSR[5]) is set. If FIFO's are disabled (FCR[0] set to zero) and THRE is set, writing a single character to the THR clears the THRE. Any additional writes to the THR before the THRE is set again causes the THR data to be overwritten. If FIFO's are enabled (FCR[0] set to one) and THRE is set, x number of characters of data may be written to the THR before the FIFO is full. The number x (default=16) is determined by the value of FIFO Depth that you set during configuration. Any attempt to write data when the FIFO is full results in the write data being lost.</p>	

Table 396: UART2\_SRBR\_STHR6\_REG (0x50001148)

Bit	Mode	Symbol	Description	Reset
15:8	-	-		0x0
7:0	R/W	SRBR_STHRx	<p>Shadow Receive Buffer Register x: This is a shadow register for the RBR and has been allocated sixteen 32-bit locations so as to accommodate burst accesses from the master. This register contains the data byte received on the serial input port (sin) in UART mode or the serial infrared input (sir_in) in infrared mode. The data in this register is valid only if the Data Ready (DR) bit in the Line status Register (LSR) is set. If FIFOs are disabled (FCR[0] set to zero), the data in the RBR must be read before the next data arrives, otherwise it will be overwritten, resulting in an overrun error. If FIFOs are enabled (FCR[0] set to one), this register accesses the head of the receive FIFO. If the receive FIFO is full and this register is not read before the next data character arrives, then the data already in the FIFO will be preserved but any incoming data will be lost. An overrun error will also occur. Shadow Transmit Holding Register 0: This is a shadow register for the THR and has been allocated sixteen 32-bit locations so as to accommodate burst accesses from the master. This register contains data to be transmitted on the serial output port (sout) in UART mode or the serial infrared output (sir_out_n) in infrared mode. Data should only be written to the THR when the THR Empty (THRE) bit (LSR[5]) is set. If FIFO's are disabled (FCR[0] set to zero) and THRE is set, writing a single character to the THR clears the THRE. Any additional writes to the THR before the THRE is set again causes the THR data to be overwritten.</p>	0x0

Bit	Mode	Symbol	Description	Reset
			If FIFO's are enabled (FCR[0] set to one) and THRE is set, x number of characters of data may be written to the THR before the FIFO is full. The number x (default=16) is determined by the value of FIFO Depth that you set during configuration. Any attempt to write data when the FIFO is full results in the write data being lost.	

Table 397: **UART2\_SRBR\_STHR7\_REG (0x5000114C)**

Bit	Mode	Symbol	Description	Reset
15:8	-	-		0x0
7:0	R/W	SRBR_STHRx	Shadow Receive Buffer Register x: This is a shadow register for the RBR and has been allocated sixteen 32-bit locations so as to accommodate burst accesses from the master. This register contains the data byte received on the serial input port (sin) in UART mode or the serial infrared input (sir_in) in infrared mode. The data in this register is valid only if the Data Ready (DR) bit in the Line status Register (LSR) is set. If FIFOs are disabled (FCR[0] set to zero), the data in the RBR must be read before the next data arrives, otherwise it will be overwritten, resulting in an overrun error. If FIFOs are enabled (FCR[0] set to one), this register accesses the head of the receive FIFO. If the receive FIFO is full and this register is not read before the next data character arrives, then the data already in the FIFO will be preserved but any incoming data will be lost. An overrun error will also occur. Shadow Transmit Holding Register 0: This is a shadow register for the THR and has been allocated sixteen 32-bit locations so as to accommodate burst accesses from the master. This register contains data to be transmitted on the serial output port (sout) in UART mode or the serial infrared output (sir_out_n) in infrared mode. Data should only be written to the THR when the THR Empty (THRE) bit (LSR[5]) is set. If FIFO's are disabled (FCR[0] set to zero) and THRE is set, writing a single character to the THR clears the THRE. Any additional writes to the THR before the THRE is set again causes the THR data to be overwritten. If FIFO's are enabled (FCR[0] set to one) and THRE is set, x number of characters of data may be written to the THR before the FIFO is full. The number x (default=16) is determined by the value of FIFO Depth that you set during configuration. Any attempt to write data when the FIFO is full results in the write data being lost.	0x0

Table 398: **UART2\_SRBR\_STHR8\_REG (0x50001150)**

Bit	Mode	Symbol	Description	Reset
15:8	-	-		0x0

Bit	Mode	Symbol	Description	Reset
7:0	R/W	SRBR_STHRx	Shadow Receive Buffer Register x: This is a shadow register for the RBR and has been allocated sixteen 32-bit locations so as to accommodate burst accesses from the master. This register contains the data byte received on the serial input port (sin) in UART mode or the serial infrared input (sir_in) in infrared mode. The data in this register is valid only if the Data Ready (DR) bit in the Line status Register (LSR) is set. If FIFOs are disabled (FCR[0] set to zero), the data in the RBR must be read before the next data arrives, otherwise it will be overwritten, resulting in an overrun error. If FIFOs are enabled (FCR[0] set to one), this register accesses the head of the receive FIFO. If the receive FIFO is full and this register is not read before the next data character arrives, then the data already in the FIFO will be preserved but any incoming data will be lost. An overrun error will also occur. Shadow Transmit Holding Register 0: This is a shadow register for the THR and has been allocated sixteen 32-bit locations so as to accommodate burst accesses from the master. This register contains data to be transmitted on the serial output port (sout) in UART mode or the serial infrared output (sir_out_n) in infrared mode. Data should only be written to the THR when the THR Empty (THRE) bit (LSR[5]) is set. If FIFO's are disabled (FCR[0] set to zero) and THRE is set, writing a single character to the THR clears the THRE. Any additional writes to the THR before the THRE is set again causes the THR data to be overwritten. If FIFO's are enabled (FCR[0] set to one) and THRE is set, x number of characters of data may be written to the THR before the FIFO is full. The number x (default=16) is determined by the value of FIFO Depth that you set during configuration. Any attempt to write data when the FIFO is full results in the write data being lost.	0x0

Table 399: UART2\_SRBR\_STHR9\_REG (0x50001154)

Bit	Mode	Symbol	Description	Reset
15:8	-	-		0x0
7:0	R/W	SRBR_STHRx	Shadow Receive Buffer Register x: This is a shadow register for the RBR and has been allocated sixteen 32-bit locations so as to accommodate burst accesses from the master. This register contains the data byte received on the serial input port (sin) in UART mode or the serial infrared input (sir_in) in infrared mode. The data in this register is valid only if the Data Ready (DR) bit in the Line status Register (LSR) is set. If FIFOs are disabled (FCR[0] set to zero), the data in the RBR must be read before the next data arrives, otherwise it will be overwritten, resulting in an overrun error. If FIFOs are enabled (FCR[0] set to one), this register accesses the head of the receive FIFO. If the receive FIFO is full and this register is not read before the next data character	0x0

Bit	Mode	Symbol	Description	Reset
			<p>arrives, then the data already in the FIFO will be preserved but any incoming data will be lost. An overrun error will also occur. Shadow Transmit Holding Register 0: This is a shadow register for the THR and has been allocated sixteen 32-bit locations so as to accommodate burst accesses from the master. This register contains data to be transmitted on the serial output port (sout) in UART mode or the serial infrared output (sir_out_n) in infrared mode. Data should only be written to the THR when the THR Empty (THRE) bit (LSR[5]) is set. If FIFO's are disabled (FCR[0] set to zero) and THRE is set, writing a single character to the THR clears the THRE. Any additional writes to the THR before the THRE is set again causes the THR data to be overwritten. If FIFO's are enabled (FCR[0] set to one) and THRE is set, x number of characters of data may be written to the THR before the FIFO is full. The number x (default=16) is determined by the value of FIFO Depth that you set during configuration. Any attempt to write data when the FIFO is full results in the write data being lost.</p>	

Table 400: [UART2\\_SRBR\\_STHR10\\_REG \(0x50001158\)](#)

Bit	Mode	Symbol	Description	Reset
15:8	-	-		0x0
7:0	R/W	SRBR_STHRx	<p>Shadow Receive Buffer Register x: This is a shadow register for the RBR and has been allocated sixteen 32-bit locations so as to accommodate burst accesses from the master. This register contains the data byte received on the serial input port (sin) in UART mode or the serial infrared input (sir_in) in infrared mode. The data in this register is valid only if the Data Ready (DR) bit in the Line status Register (LSR) is set. If FIFOs are disabled (FCR[0] set to zero), the data in the RBR must be read before the next data arrives, otherwise it will be overwritten, resulting in an overrun error. If FIFOs are enabled (FCR[0] set to one), this register accesses the head of the receive FIFO. If the receive FIFO is full and this register is not read before the next data character arrives, then the data already in the FIFO will be preserved but any incoming data will be lost. An overrun error will also occur. Shadow Transmit Holding Register 0: This is a shadow register for the THR and has been allocated sixteen 32-bit locations so as to accommodate burst accesses from the master. This register contains data to be transmitted on the serial output port (sout) in UART mode or the serial infrared output (sir_out_n) in infrared mode. Data should only be written to the THR when the THR Empty (THRE) bit (LSR[5]) is set. If FIFO's are disabled (FCR[0] set to zero) and THRE is set, writing a single character to the THR clears the THRE. Any additional writes to the THR before the THRE is set again causes the THR data to be overwritten.</p>	0x0



Bit	Mode	Symbol	Description	Reset
			If FIFO's are enabled (FCR[0] set to one) and THRE is set, x number of characters of data may be written to the THR before the FIFO is full. The number x (default=16) is determined by the value of FIFO Depth that you set during configuration. Any attempt to write data when the FIFO is full results in the write data being lost.	

Table 401: **UART2\_SRBR\_STHR11\_REG (0x5000115C)**

Bit	Mode	Symbol	Description	Reset
15:8	-	-		0x0
7:0	R/W	SRBR_STHRx	Shadow Receive Buffer Register x: This is a shadow register for the RBR and has been allocated sixteen 32-bit locations so as to accommodate burst accesses from the master. This register contains the data byte received on the serial input port (sin) in UART mode or the serial infrared input (sir_in) in infrared mode. The data in this register is valid only if the Data Ready (DR) bit in the Line status Register (LSR) is set. If FIFOs are disabled (FCR[0] set to zero), the data in the RBR must be read before the next data arrives, otherwise it will be overwritten, resulting in an overrun error. If FIFOs are enabled (FCR[0] set to one), this register accesses the head of the receive FIFO. If the receive FIFO is full and this register is not read before the next data character arrives, then the data already in the FIFO will be preserved but any incoming data will be lost. An overrun error will also occur. Shadow Transmit Holding Register 0: This is a shadow register for the THR and has been allocated sixteen 32-bit locations so as to accommodate burst accesses from the master. This register contains data to be transmitted on the serial output port (sout) in UART mode or the serial infrared output (sir_out_n) in infrared mode. Data should only be written to the THR when the THR Empty (THRE) bit (LSR[5]) is set. If FIFO's are disabled (FCR[0] set to zero) and THRE is set, writing a single character to the THR clears the THRE. Any additional writes to the THR before the THRE is set again causes the THR data to be overwritten. If FIFO's are enabled (FCR[0] set to one) and THRE is set, x number of characters of data may be written to the THR before the FIFO is full. The number x (default=16) is determined by the value of FIFO Depth that you set during configuration. Any attempt to write data when the FIFO is full results in the write data being lost.	0x0

Table 402: **UART2\_SRBR\_STHR12\_REG (0x50001160)**

Bit	Mode	Symbol	Description	Reset
15:8	-	-		0x0



Bit	Mode	Symbol	Description	Reset
7:0	R/W	SRBR_STHRx	<p>Shadow Receive Buffer Register x: This is a shadow register for the RBR and has been allocated sixteen 32-bit locations so as to accommodate burst accesses from the master. This register contains the data byte received on the serial input port (sin) in UART mode or the serial infrared input (sir_in) in infrared mode. The data in this register is valid only if the Data Ready (DR) bit in the Line status Register (LSR) is set. If FIFOs are disabled (FCR[0] set to zero), the data in the RBR must be read before the next data arrives, otherwise it will be overwritten, resulting in an overrun error. If FIFOs are enabled (FCR[0] set to one), this register accesses the head of the receive FIFO. If the receive FIFO is full and this register is not read before the next data character arrives, then the data already in the FIFO will be preserved but any incoming data will be lost. An overrun error will also occur.</p> <p>Shadow Transmit Holding Register 0: This is a shadow register for the THR and has been allocated sixteen 32-bit locations so as to accommodate burst accesses from the master. This register contains data to be transmitted on the serial output port (sout) in UART mode or the serial infrared output (sir_out_n) in infrared mode. Data should only be written to the THR when the THR Empty (THRE) bit (LSR[5]) is set. If FIFO's are disabled (FCR[0] set to zero) and THRE is set, writing a single character to the THR clears the THRE. Any additional writes to the THR before the THRE is set again causes the THR data to be overwritten. If FIFO's are enabled (FCR[0] set to one) and THRE is set, x number of characters of data may be written to the THR before the FIFO is full. The number x (default=16) is determined by the value of FIFO Depth that you set during configuration. Any attempt to write data when the FIFO is full results in the write data being lost.</p>	0x0

Table 403: [UART2\\_SRBR\\_STHR13\\_REG \(0x50001164\)](#)

Bit	Mode	Symbol	Description	Reset
15:8	-	-		0x0
7:0	R/W	SRBR_STHRx	<p>Shadow Receive Buffer Register x: This is a shadow register for the RBR and has been allocated sixteen 32-bit locations so as to accommodate burst accesses from the master. This register contains the data byte received on the serial input port (sin) in UART mode or the serial infrared input (sir_in) in infrared mode. The data in this register is valid only if the Data Ready (DR) bit in the Line status Register (LSR) is set. If FIFOs are disabled (FCR[0] set to zero), the data in the RBR must be read before the next data arrives, otherwise it will be overwritten, resulting in an overrun error. If FIFOs are enabled (FCR[0] set to one), this register accesses the head of the receive FIFO. If the receive FIFO is full and this register is not read before the next data character</p>	0x0

Bit	Mode	Symbol	Description	Reset
			<p>arrives, then the data already in the FIFO will be preserved but any incoming data will be lost. An overrun error will also occur. Shadow Transmit Holding Register 0: This is a shadow register for the THR and has been allocated sixteen 32-bit locations so as to accommodate burst accesses from the master. This register contains data to be transmitted on the serial output port (sout) in UART mode or the serial infrared output (sir_out_n) in infrared mode. Data should only be written to the THR when the THR Empty (THRE) bit (LSR[5]) is set. If FIFO's are disabled (FCR[0] set to zero) and THRE is set, writing a single character to the THR clears the THRE. Any additional writes to the THR before the THRE is set again causes the THR data to be overwritten. If FIFO's are enabled (FCR[0] set to one) and THRE is set, x number of characters of data may be written to the THR before the FIFO is full. The number x (default=16) is determined by the value of FIFO Depth that you set during configuration. Any attempt to write data when the FIFO is full results in the write data being lost.</p>	

Table 404: **UART2\_SRBR\_STHR14\_REG (0x50001168)**

Bit	Mode	Symbol	Description	Reset
15:8	-	-		0x0
7:0	R/W	SRBR_STHRx	<p>Shadow Receive Buffer Register x: This is a shadow register for the RBR and has been allocated sixteen 32-bit locations so as to accommodate burst accesses from the master. This register contains the data byte received on the serial input port (sin) in UART mode or the serial infrared input (sir_in) in infrared mode. The data in this register is valid only if the Data Ready (DR) bit in the Line status Register (LSR) is set. If FIFOs are disabled (FCR[0] set to zero), the data in the RBR must be read before the next data arrives, otherwise it will be overwritten, resulting in an overrun error. If FIFOs are enabled (FCR[0] set to one), this register accesses the head of the receive FIFO. If the receive FIFO is full and this register is not read before the next data character arrives, then the data already in the FIFO will be preserved but any incoming data will be lost. An overrun error will also occur. Shadow Transmit Holding Register 0: This is a shadow register for the THR and has been allocated sixteen 32-bit locations so as to accommodate burst accesses from the master. This register contains data to be transmitted on the serial output port (sout) in UART mode or the serial infrared output (sir_out_n) in infrared mode. Data should only be written to the THR when the THR Empty (THRE) bit (LSR[5]) is set. If FIFO's are disabled (FCR[0] set to zero) and THRE is set, writing a single character to the THR clears the THRE. Any additional writes to the THR before the THRE is set again causes the THR data to be overwritten.</p>	0x0

Bit	Mode	Symbol	Description	Reset
			If FIFO's are enabled (FCR[0] set to one) and THRE is set, x number of characters of data may be written to the THR before the FIFO is full. The number x (default=16) is determined by the value of FIFO Depth that you set during configuration. Any attempt to write data when the FIFO is full results in the write data being lost.	

Table 405: **UART2\_SRBR\_STHR15\_REG (0x5000116C)**

Bit	Mode	Symbol	Description	Reset
15:8	-	-		0x0
7:0	R/W	SRBR_STHRx	Shadow Receive Buffer Register x: This is a shadow register for the RBR and has been allocated sixteen 32-bit locations so as to accommodate burst accesses from the master. This register contains the data byte received on the serial input port (sin) in UART mode or the serial infrared input (sir_in) in infrared mode. The data in this register is valid only if the Data Ready (DR) bit in the Line status Register (LSR) is set. If FIFOs are disabled (FCR[0] set to zero), the data in the RBR must be read before the next data arrives, otherwise it will be overwritten, resulting in an overrun error. If FIFOs are enabled (FCR[0] set to one), this register accesses the head of the receive FIFO. If the receive FIFO is full and this register is not read before the next data character arrives, then the data already in the FIFO will be preserved but any incoming data will be lost. An overrun error will also occur. Shadow Transmit Holding Register 0: This is a shadow register for the THR and has been allocated sixteen 32-bit locations so as to accommodate burst accesses from the master. This register contains data to be transmitted on the serial output port (sout) in UART mode or the serial infrared output (sir_out_n) in infrared mode. Data should only be written to the THR when the THR Empty (THRE) bit (LSR[5]) is set. If FIFO's are disabled (FCR[0] set to zero) and THRE is set, writing a single character to the THR clears the THRE. Any additional writes to the THR before the THRE is set again causes the THR data to be overwritten. If FIFO's are enabled (FCR[0] set to one) and THRE is set, x number of characters of data may be written to the THR before the FIFO is full. The number x (default=16) is determined by the value of FIFO Depth that you set during configuration. Any attempt to write data when the FIFO is full results in the write data being lost.	0x0

Table 406: **UART2\_FAR\_REG (0x50001170)**

Bit	Mode	Symbol	Description	Reset
0	R	UART_FAR	Description: Writes will have no effect when FIFO_ACCESS == No, always readable. This	0x0

Bit	Mode	Symbol	Description	Reset
			register is use to enable a FIFO access mode for testing, so that the receive FIFO can be written by the master and the transmit FIFO can be read by the master when FIFO's are implemented and enabled. When FIFO's are not implemented or not enabled it allows the RBR to be written by the master and the THR to be read by the master. 0 = FIFO access mode disabled 1 = FIFO access mode enabled Note, that when the FIFO access mode is enabled/disabled, the control portion of the receive FIFO and transmit FIFO is reset and the FIFO's are treated as empty.	

Table 407: UART2\_USR\_REG (0x5000117C)

Bit	Mode	Symbol	Description	Reset
15:5	-	-		0x0
4	R	UART_RFF	Receive FIFO Full. This is used to indicate that the receive FIFO is completely full. 0 = Receive FIFO not full 1 = Receive FIFO Full This bit is cleared when the RX FIFO is no longer full.	0x0
3	R	UART_RFNE	Receive FIFO Not Empty. This is used to indicate that the receive FIFO contains one or more entries. 0 = Receive FIFO is empty 1 = Receive FIFO is not empty This bit is cleared when the RX FIFO is empty.	0x0
2	R	UART_TFE	Transmit FIFO Empty. This is used to indicate that the transmit FIFO is completely empty. 0 = Transmit FIFO is not empty 1 = Transmit FIFO is empty This bit is cleared when the TX FIFO is no longer empty.	0x1
1	R	UART_TFNF	Transmit FIFO Not Full. This is used to indicate that the transmit FIFO in not full. 0 = Transmit FIFO is full 1 = Transmit FIFO is not full This bit is cleared when the TX FIFO is full.	0x1
0	R	UART_BUSY	UART Busy. This indicates that a serial transfer is in progress, when cleared indicates that the DW_apb_uart is idle or inactive. 0 - DW_apb_uart is idle or inactive 1 - DW_apb_uart is busy (actively transferring data) Note that it is possible for the UART Busy bit to be cleared even though a new character may have been sent from another device. That is, if the DW_apb_uart has no data in the THR and RBR and there is no transmission in progress and a start bit of a new character has	0x0

Bit	Mode	Symbol	Description	Reset
			just reached the DW_apb_uart. This is due to the fact that a valid start is not seen until the middle of the bit period and this duration is dependent on the baud divisor that has been programmed. If a second system clock has been implemented (CLOCK_MODE == Enabled) the assertion of this bit will also be delayed by several cycles of the slower clock.	

Table 408: UART2\_TFL\_REG (0x50001180)

Bit	Mode	Symbol	Description	Reset
4:0	R	UART_TRANSMIT_FIFO_LEVEL	Transmit FIFO Level. This indicates the number of data entries in the transmit FIFO.	0x0

Table 409: UART2\_RFL\_REG (0x50001184)

Bit	Mode	Symbol	Description	Reset
4:0	R	UART_RECEIVE_FIFO_LEVEL	Receive FIFO Level. This indicates the number of data entries in the receive FIFO.	0x0

Table 410: UART2\_SRR\_REG (0x50001188)

Bit	Mode	Symbol	Description	Reset
15:3	-	-		0x0
2	W	UART_XFR	XMIT FIFO Reset. This is a shadow register for the XMIT FIFO Reset bit (FCR[2]). This can be used to remove the burden on software having to store previously written FCR values (which are pretty static) just to reset the transmit FIFO. This resets the control portion of the transmit FIFO and treats the FIFO as empty. Note that this bit is 'self-clearing'. It is not necessary to clear this bit.	0x0
1	W	UART_RFR	RCVR FIFO Reset. This is a shadow register for the RCVR FIFO Reset bit (FCR[1]). This can be used to remove the burden on software having to store previously written FCR values (which are pretty static) just to reset the receive FIFO. This resets the control portion of the receive FIFO and treats the FIFO as empty. Note that this bit is 'self-clearing'. It is not necessary to clear this bit.	0x0
0	W	UART_UR	UART Reset. This asynchronously resets the UART Ctrl and synchronously removes the reset assertion. For a two clock implementation both pclk and sclk domains are reset.	0x0

Table 411: UART2\_SBCR\_REG (0x50001190)

Bit	Mode	Symbol	Description	Reset
15:1	-	-		0x0
0	R/W	UART_SHADOW_B REAK_CONTROL	<p>Shadow Break Control Bit.</p> <p>This is a shadow register for the Break bit (LCR[6]), this can be used to remove the burden of having to performing a read modify write on the LCR. This is used to cause a break condition to be transmitted to the receiving device.</p> <p>If set to one the serial output is forced to the spacing (logic 0) state. When not in Loopback Mode, as determined by MCR[4], the sout line is forced low until the Break bit is cleared.</p> <p>If SIR_MODE active (MCR[6] = 1) the sir_out_n line is continuously pulsed. When in Loopback Mode, the break condition is internally looped back to the receiver.</p>	0x0

Table 412: UART2\_SDMAM\_REG (0x50001194)

Bit	Mode	Symbol	Description	Reset
15:1	-	-		0x0
0	R/W	UART_SHADOW_D MA_MODE	<p>Shadow DMA Mode.</p> <p>This is a shadow register for the DMA mode bit (FCR[3]). This can be used to remove the burden of having to store the previously written value to the FCR in memory and having to mask this value so that only the DMA Mode bit gets updated. This determines the DMA signalling mode used for the dma_tx_req_n and dma_rx_req_n output signals.</p> <p>0 = mode 0 1 = mode 1</p>	0x0

Table 413: UART2\_SFE\_REG (0x50001198)

Bit	Mode	Symbol	Description	Reset
15:1	-	-		0x0
0	R/W	UART_SHADOW_F IFO_ENABLE	<p>Shadow FIFO Enable.</p> <p>This is a shadow register for the FIFO enable bit (FCR[0]). This can be used to remove the burden of having to store the previously written value to the FCR in memory and having to mask this value so that only the FIFO enable bit gets updated. This enables/disables the transmit (XMIT) and receive (RCVR) FIFOs. If this bit is set to zero (disabled) after being enabled then both the XMIT and RCVR controller portion of FIFOs are reset.</p>	0x0

Table 414: UART2\_SRT\_REG (0x5000119C)

Bit	Mode	Symbol	Description	Reset
15:2	-	-		0x0
1:0	R/W	UART_SHADOW_RCVR_TRIGGER	<p>Shadow RCVR Trigger.</p> <p>This is a shadow register for the RCVR trigger bits (FCR[7:6]). This can be used to remove the burden of having to store the previously written value to the FCR in memory and having to mask this value so that only the RCVR trigger bit gets updated.</p> <p>This is used to select the trigger level in the receiver FIFO at which the Received Data Available Interrupt is generated. It also determines when the dma_rx_req_n signal is asserted when DMA Mode (FCR[3]) = 1. The following trigger levels are supported:</p> <p>00 = 1 character in the FIFO            01 = FIFO ¼ full            10 = FIFO ½ full            11 = FIFO 2 less than full</p>	0x0

Table 415: UART2\_STET\_REG (0x500011A0)

Bit	Mode	Symbol	Description	Reset
15:2	-	-		0x0
1:0	R/W	UART_SHADOW_TX_EMPTY_TRIGGER	<p>Shadow TX Empty Trigger.</p> <p>This is a shadow register for the TX empty trigger bits (FCR[5:4]). This can be used to remove the burden of having to store the previously written value to the FCR in memory and having to mask this value so that only the TX empty trigger bit gets updated.</p> <p>This is used to select the empty threshold level at which the THRE Interrupts are generated when the mode is active. The following trigger levels are supported:</p> <p>00 = FIFO empty            01 = 2 characters in the FIFO            10 = FIFO ¼ full            11 = FIFO ½ full</p>	0x0

Table 416: UART2\_HTX\_REG (0x500011A4)

Bit	Mode	Symbol	Description	Reset
15:1	-	-		0x0
0	R/W	UART_HALT_TX	<p>This register is use to halt transmissions for testing, so that the transmit FIFO can be filled by the master when FIFOs are implemented and enabled.</p> <p>0 = Halt TX disabled            1 = Halt TX enabled</p>	0x0

Bit	Mode	Symbol	Description	Reset
			Note, if FIFOs are implemented and not enabled, the setting of the halt TX register has no effect on operation.	

Table 417: **UART2\_DMASA\_REG (0x500011A8)**

Bit	Mode	Symbol	Description	Reset
0	W	DMASA	This register is use to perform DMA software acknowledge if a transfer needs to be terminated due to an error condition. For example, if the DMA disables the channel, then the DW_apb_uart should clear its request. This will cause the TX request, TX single, RX request and RX single signals to de-assert. Note that this bit is 'self-clearing' and it is not necessary to clear this bit.	0x0

Table 418: **UART2\_DLF\_REG (0x500011C0)**

Bit	Mode	Symbol	Description	Reset
3:0	R/W	UART_DLF	The fractional value is added to integer value set by DLH, DLL. Fractional value is equal UART_DLF/16	0x0

Table 419: **UART2\_UCV\_REG (0x500011F8)**

Bit	Mode	Symbol	Description	Reset
15:0	R	UCV	Component Version	0x352A

Table 420: **UART2\_UCV\_HIGH\_REG (0x500011FA)**

Bit	Mode	Symbol	Description	Reset
15:0	R	UCV	Component Version	0x3331

Table 421: **UART2\_CTR\_REG (0x500011FC)**

Bit	Mode	Symbol	Description	Reset
15:0	R	CTR	Component Type Register	0x110

Table 422: **UART2\_CTR\_HIGH\_REG (0x500011FE)**

Bit	Mode	Symbol	Description	Reset
15:0	R	CTR	Component Type Register	0x4457





## 31.18 Chip Version Registers

Table 423: Register map Version

Address	Register	Description
0x50003200	CHIP_ID1_REG	Chip identification register 1.
0x50003204	CHIP_ID2_REG	Chip identification register 2.
0x50003208	CHIP_ID3_REG	Chip identification register 3.
0x5000320C	CHIP_ID4_REG	Chip identification register 4.

Table 424: CHIP\_ID1\_REG (0x50003200)

Bit	Mode	Symbol	Description	Reset
7:0	R	CHIP_ID1	First character of device type "2632" in ASCII.	0x32

Table 425: CHIP\_ID2\_REG (0x50003204)

Bit	Mode	Symbol	Description	Reset
7:0	R	CHIP_ID2	Second character of device type "2632" in ASCII.	0x36

Table 426: CHIP\_ID3\_REG (0x50003208)

Bit	Mode	Symbol	Description	Reset
7:0	R	CHIP_ID3	Third character of device type "2632" in ASCII.	0x33

Table 427: CHIP\_ID4\_REG (0x5000320C)

Bit	Mode	Symbol	Description	Reset
7:0	R	CHIP_ID4	Fourth character of device type "2632" in ASCII.	0x32

## 31.19 Wake-Up Registers

Table 428: Register map WKUP

Address	Register	Description
0x50000100	WKUP_CTRL_REG	Control register for the wakeup counter
0x50000102	WKUP_COMPARE_REG	Number of events before wakeup interrupt
0x50000104	WKUP_IRQ_STATUS_REG	Reset wakeup interrupt
0x50000106	WKUP_COUNTER_REG	Actual number of events of the wakeup counter
0x50000108	WKUP_SELECT_GPIO_REG	Select which inputs from P0 port can trigger wkup counter
0x5000010A	WKUP2_SELECT_GPIO_REG	Select which inputs from P1 port can trigger wkup counter
0x5000010C	WKUP_POL_GPIO_REG	Select the sensitivity polarity for each P0 input
0x5000010E	WKUP2_POL_GPIO_REG	Select the sensitivity polarity for each P1 input

Table 429: WKUP\_CTRL\_REG (0x50000100)

Bit	Mode	Symbol	Description	Reset
8	R/W	WKUP2_ENABLE_IRQ	0 = no interrupt will be generated 1 = if the event counter2 reaches the value set by WKUP_COMPARE_REG an IRQ will be generated	0x0
7	R/W	WKUP_ENABLE_IRQ	0 = no interrupt will be generated 1 = if the event counter reaches the value set by WKUP_COMPARE_REG an IRQ will be generated	0x0
6	R/W	WKUP_SFT_KEYHIT	0 = no effect 1 = emulate key hit. The event counter and counter2 will increment by 1 (after debouncing if enabled). First make this bit 0 before any new key hit can be sensed.	0x0
5:0	R/W	WKUP_DEB_VALUE	Keyboard debounce time (N*1 ms with N = 1 to 63). 0x0: no debouncing 0x1 to 0x3F: 1 ms to 63 ms debounce time	0x0

Table 430: WKUP\_COMPARE\_REG (0x50000102)

Bit	Mode	Symbol	Description	Reset
7:0	R/W	WKUP_COMPARE	Defines the number of events -1 that have to be counted before the wakeup interrupt will be given. value 0 means one event.	0x0

Table 431: **WKUP\_IRQ\_STATUS\_REG (0x50000104)**

Bit	Mode	Symbol	Description	Reset
3	R0/W	WKUP2_CNTR_RST	writing 1 will reset the event2 counter	0x0
2	R0/W	WKUP_CNTR_RST	writing 1 will reset the event counter	0x0
1	R/W	WKUP2_IRQ_STATUS	Gives 1 when there is a wkup2 pending IRQ. Writing 1 will reset the interrupt.	0x0
0	R/W	WKUP_IRQ_STATUS	Gives 1 when there is a wkup pending IRQ. Writing 1 will reset the interrupt.	0x0

Table 432: **WKUP\_COUNTER\_REG (0x50000106)**

Bit	Mode	Symbol	Description	Reset
15:8	R	EVENT2_VALUE	This value represents the number of events that have been counted so far. It will be reset by writing to the WKUP_CNTR_RST bit field of the WKUP_IRQ_STATUS_REG	0x0
7:0	R	EVENT_VALUE	This value represents the number of events that have been counted so far. It will be reset by writing to the WKUP_CNTR_RST bit field of the WKUP_IRQ_STATUS_REG.	0x0

Table 433: **WKUP\_SELECT\_GPIO\_REG (0x50000108)**

Bit	Mode	Symbol	Description	Reset
11:0	R/W	WKUP_SELECT_GPIO	0 = input P0x is not enabled for wakeup event counter 1 = input P0x is enabled for wakeup event counter	0x0

Table 434: **WKUP2\_SELECT\_GPIO\_REG (0x5000010A)**

Bit	Mode	Symbol	Description	Reset
11:0	R/W	WKUP2_SELECT_GPIO	0 = input P0x is not enabled for wakeup event counter 1 = input P0x is enabled for wakeup event counter	0x0

Table 435: **WKUP\_POL\_GPIO\_REG (0x5000010C)**

Bit	Mode	Symbol	Description	Reset
11:0	R/W	WKUP_POL_GPIO	0 = the enabled input P0x increments the event counter if that input goes high 1 = the enabled input P0x increments the event counter if that input goes low	0x0

**Table 436: WKUP2\_POL\_GPIO\_REG (0x5000010E)**

Bit	Mode	Symbol	Description	Reset
11:0	R/W	WKUP2_POL_GPIO	0 = the enabled input P0x increments the event2 counter if that input goes high 1 = the enabled input P0x increments the event2 counter if that input goes low	0x0

31.20 Watchdog Registers

Table 437: Register map WDOG

Address	Register	Description
0x50003100	WATCHDOG_REG	Watchdog timer register.
0x50003102	WATCHDOG_CTRL_REG	Watchdog control register.

Table 438: WATCHDOG\_REG (0x50003100)

Bit	Mode	Symbol	Description	Reset
15:9	R0/W	WDOG_WEN	0000.000 = Write enable for Watchdog timer else Write disable. This filter prevents unintentional presetting the watchdog with a SW run-away.	0x0
8	R/W	WDOG_VAL_NEG	0 = Watchdog timer value is positive. 1 = Watchdog timer value is negative.	0x0
7:0	R/W	WDOG_VAL	<u>Write</u> : Watchdog timer reload value. Note that all bits 15-9 must be 0 to reload this register. <u>Read</u> : Actual Watchdog timer value. Decrement by 1 every 10.24 msec. Bit 8 indicates a negative counter value. 2, 1, 0, 1FF <sub>16</sub> , 1FE <sub>16</sub> etc. An NMI or WDOG (SYS) reset is generated under the following conditions: If WATCHDOG_CTRL_REG[NMI_RST] = 0 then If WDOG_VAL = 0 -> NMI (Non Maskable Interrupt) if WDOG_VAL = 1F0 <sub>16</sub> -> WDOG reset -> reload FF <sub>16</sub> If WATCHDOG_CTRL_REG[NMI_RST] = 1 then if WDOG_VAL <= 0 -> WDOG reset -> reload FF <sub>16</sub>	0xFF

Table 439: WATCHDOG\_CTRL\_REG (0x50003102)

Bit	Mode	Symbol	Description	Reset
15:2	-	-		0x0
1	R/W	-		0x0
0	R/W	NMI_RST	0 = Watchdog timer generates NMI at value 0, and WDOG (SYS) reset at <=-16. Timer can be frozen /resumed using SET_FREEZE_REG[FRZ_WDOG]/ RESET_FREEZE_REG[FRZ_WDOG]. 1 = Watchdog timer generates a WDOG (SYS) reset at value 0 and can not be frozen by Software. Note that this bit can only be set to 1 by SW and only be reset with a WDOG (SYS) reset or SW reset. The watchdog is always frozen when the Cortex-M0 is halted in DEBUG State.	0x0



## 32 Ordering Information

**Table 440: Ordering Information (Samples)**

Part Number	Package	Size (mm)	Shipment Form	Pack Quantity
DA14530-00000FX2	FCGQFN24	2.2 × 3.0	Reel	100/1000

**Table 441: Ordering Information (Production)**

Part Number	Package	Size (mm)	Shipment Form	Pack Quantity
DA14530-00000FX2	FCGQFN24	2.2 × 3.0	Reel	4000

**Part Number Legend:**

DA14530-RRXXXYYZ

RR: chip revision number

XXX: variant (000: No Flash)

YY: package code (FX: FCGQFN24, OG: WLCSP17)

Z: packing method (1: Tray, 2: Reel, A: Mini-Reel)



### 33 Package Information

#### 33.1 Moisture Sensitivity Level (MSL)

The MSL is an indicator for the maximum allowable time period (floor life time) in which a moisture sensitive plastic device, once removed from the dry bag, can be exposed to an environment with a maximum temperature of 30°C and a maximum relative humidity of 60% relative humidity (RH.) before the solder reflow process.

FCGQFN packages are qualified for MSL 1.

**Table 442: MSL Classification**

MSL Level	Floor Lifetime	Conditions
MSL 4	72 hours	30°C/60% RH
MSL 3	168 hours	30°C/60% RH
MSL 2A	4 weeks	30°C/60% RH
MSL 2	1 year	30°C/60% RH
MSL 1	Unlimited	30°C/85% RH

#### 33.2 Soldering Information

Refer to the JEDEC standard J-STD-020 for relevant soldering information. This document can be downloaded from <http://www.jedec.org>.

#### 33.3 Package Outlines

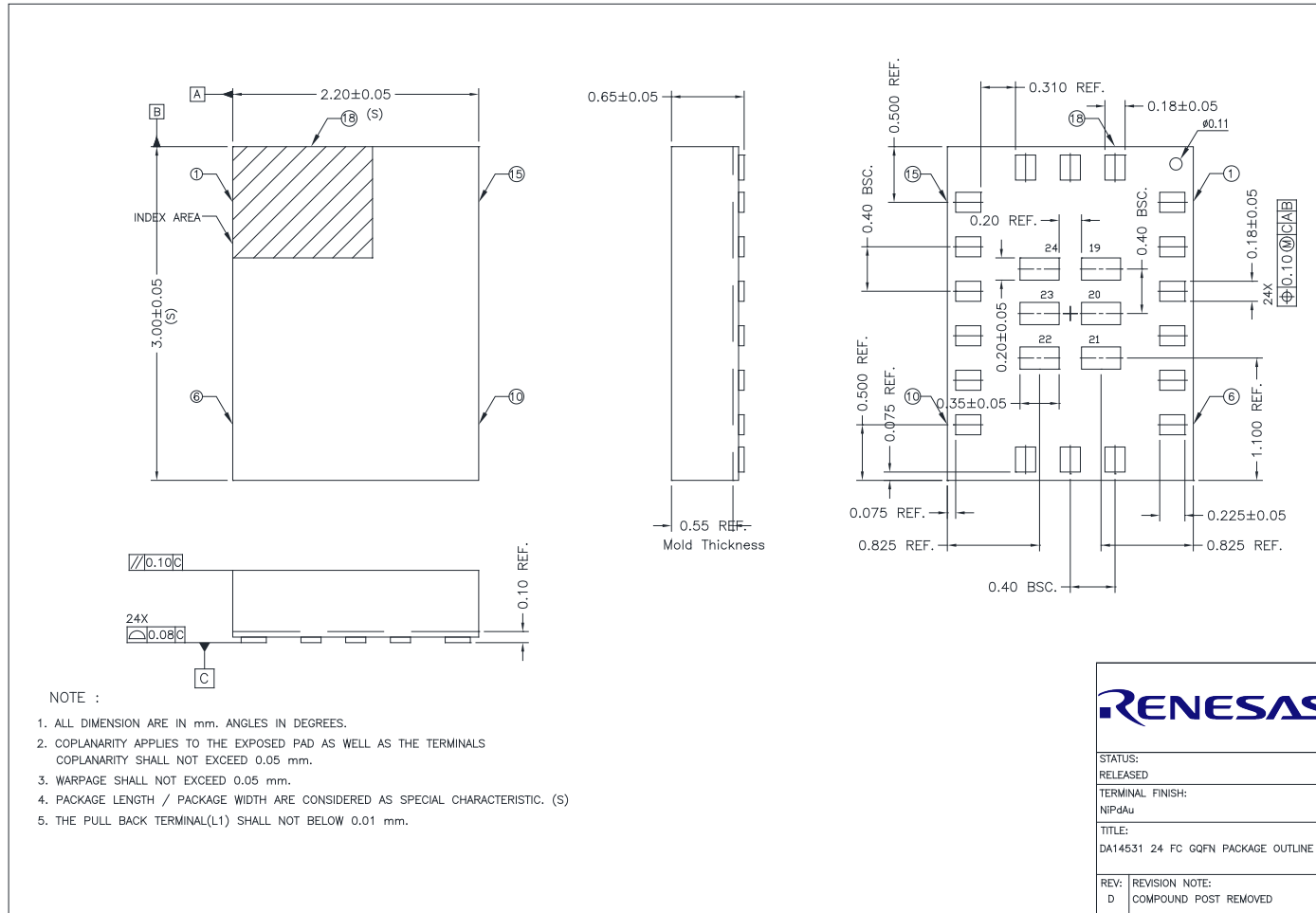

Figure 72: FCGQFN24 Package Outline Drawing

## Revision History

Revision	Date	Description
3.4	21-Dec-2021	Updated logo, disclaimer, copyright.
3.3	30-Aug-2021	Datasheet status: Final. Product status: Production
		<ul style="list-style-type: none"> <li>Updated Section 11.3 OTP Controller Programming, OTPC_MODE_REG[OTPC_MODE_MODE]=0x1 for STBY mode</li> <li>Updated Absolute Maximum Ratings table, <math>V_{ESD\_HBM\_FCGQFN24}</math> is reduced to 2.5 kV for RFIOp and RFIOm pins only</li> </ul>
3.2	9-Mar-2021	Datasheet status: Final.
		<ul style="list-style-type: none"> <li>Updated OTP programming range in Recommended Operating Conditions</li> <li>Removed duplicated register names in "Reset Signals and Registers" table</li> <li>Removed false link in OTP controller chapter</li> </ul>
3.1	8-Oct-2020	Datasheet status: Final.
		<ul style="list-style-type: none"> <li>Corrected typos</li> <li>Removed high speed paragraph from I2C chapter</li> </ul>
3.0	16-Mar-2020	Datasheet status: Final.

### Status Definitions

Revision	Datasheet Status	Product Status	Definition
1.<n>	Target	Development	This datasheet contains the design specifications for product development. Specifications may be changed in any manner without notice.
2.<n>	Preliminary	Qualification	This datasheet contains the specifications and preliminary characterization data for products in pre-production. Specifications may be changed at any time without notice in order to improve the design.
3.<n>	Final	Production	This datasheet contains the final specifications for products in volume production. The specifications may be changed at any time in order to improve the design, manufacturing and supply. Major specification changes are communicated via Customer Product Notifications. Datasheet changes are communicated via <a href="http://www.dialog-semiconductor.com">www.dialog-semiconductor.com</a> .
4.<n>	Obsolete	Archived	This datasheet contains the specifications for discontinued products. The information is provided for reference only.

### RoHS Compliance

Dialog Semiconductor's suppliers certify that its products are in compliance with the requirements of Directive 2011/65/EU of the European Parliament on the restriction of the use of certain hazardous substances in electrical and electronic equipment. RoHS certificates from our suppliers are available on request.

## IMPORTANT NOTICE AND DISCLAIMER

RENESAS ELECTRONICS CORPORATION AND ITS SUBSIDIARIES (“RENESAS”) PROVIDES TECHNICAL SPECIFICATIONS AND RELIABILITY DATA (INCLUDING DATASHEETS), DESIGN RESOURCES (INCLUDING REFERENCE DESIGNS), APPLICATION OR OTHER DESIGN ADVICE, WEB TOOLS, SAFETY INFORMATION, AND OTHER RESOURCES “AS IS” AND WITH ALL FAULTS, AND DISCLAIMS ALL WARRANTIES, EXPRESS OR IMPLIED, INCLUDING, WITHOUT LIMITATION, ANY IMPLIED WARRANTIES OF MERCHANTABILITY, FITNESS FOR A PARTICULAR PURPOSE, OR NON-INFRINGEMENT OF THIRD-PARTY INTELLECTUAL PROPERTY RIGHTS.

These resources are intended for developers who are designing with Renesas products. You are solely responsible for (1) selecting the appropriate products for your application, (2) designing, validating, and testing your application, and (3) ensuring your application meets applicable standards, and any other safety, security, or other requirements. These resources are subject to change without notice. Renesas grants you permission to use these resources only to develop an application that uses Renesas products. Other reproduction or use of these resources is strictly prohibited. No license is granted to any other Renesas intellectual property or to any third-party intellectual property. Renesas disclaims responsibility for, and you will fully indemnify Renesas and its representatives against, any claims, damages, costs, losses, or liabilities arising from your use of these resources. Renesas' products are provided only subject to Renesas' Terms and Conditions of Sale or other applicable terms agreed to in writing. No use of any Renesas resources expands or otherwise alters any applicable warranties or warranty disclaimers for these products.

(Disclaimer Rev.1.01 Jan 2024)

### Corporate Headquarters

TOYOSU FORESIA, 3-2-24 Toyosu,  
Koto-ku, Tokyo 135-0061, Japan  
[www.renesas.com](http://www.renesas.com)

### Trademarks

Renesas and the Renesas logo are trademarks of Renesas Electronics Corporation. All trademarks and registered trademarks are the property of their respective owners.

### Contact Information

For further information on a product, technology, the most up-to-date version of a document, or your nearest sales office, please visit [www.renesas.com/contact-us/](http://www.renesas.com/contact-us/).