System PMIC for Mobile and Automotive Applications

General Description

DA9063L is a high current system PMIC suitable for dual- and quad-core processors used in smartphones, tablets, ultra-books, and other handheld and automotive applications that require up to 5 A core processor supply.

DA9063L contains six DC-DC buck converters designed for small external 1 μ H inductors capable of supplying in total up to 12 A continuous output (0.3 V to 3.3 V). The buck converters do not require external Schottky diodes. They dynamically optimize their efficiency depending on the load current using an Automatic Sleep mode. The bucks incorporate pin and s/w controlled Dynamic Voltage Control (DVC) to support processor load adaptive adjustment of the supply voltage. One buck can also be used in a DDR memory termination mode.

Five SmartMirror™ programmable LDO regulators are incorporated, rated up to 300 mA. All support remote capacitor placement and can support operation from a low 1.5 V/1.8 V input voltage: this allows the linear regulators to be cascaded with a suitable buck supply to improve overall system efficiency.

Current limited switches provide support for external peripherals such as external accessory or memory cards.

There are four distinct operating modes consuming < 20 μ A. A system monitor watchdog can be enabled in ACTIVE mode.

The DA9063L provides an OTP start-up sequencing engine that offers autonomous hardware system start-up or software controlled start-up and configurable power modes. The on key detects the button press time and offers configurable key lock and application shutdown functions. Up to 16 freely configurable GPIO pins can perform system functions, including: keypad supervision, application wakeup, and timing controlled external regulator, power switch, or other IC enable.

An integrated 9-channel ADC includes advanced voltage monitoring, internal temperature supervision, three general-purpose channels with programmable high/low thresholds, an integrated current source for resistive measurements, and system voltage monitoring with a programmable low-voltage warning. The ADC has 8-bit resolution in AUTO mode and 10-bit resolution in manual conversion mode.

Three RGB-LED driver pins are provided with PWM control.

LDO8 can be configured as a 6-bit, PWM-controlled, vibration motor driver with automatic battery voltage correction.

System PMIC for Mobile and Automotive Applications

Key Features

- Input voltage 2.8 V to 5.5 V
- 6 buck converters, 0.3 V to 3.34 V up to 2.5 A
 - Dual-phase mode up to 5 A
 - Merged mode up to 3 A
 - DDR VTT supply mode
 - DVS support
- 3 MHz switching frequency allows use of low profile 1 μ H inductors
- Integrated power switches
- 5 LDO regulators, 0.9 V to 3.6 V up to 300 mA
 - 1 low-noise
 - 1 with DVS
 - 4 with current-limited switch option
- I²C serial interface for system communication and control
- System supply monitoring
- Junction temperature monitoring
- Watchdog timer
- Up to 16 flexible GPIO pins for enhanced wakeup and peripheral control
- RGB-LED driver (PWM) with autonomous flashing
- PWM vibration motor driver
- 10-bit ADC with nine channels and configurable alarm thresholds
- Two package variants:
 - 100 VFBGA, 8.0 mm x 8.0 mm x 1.0 mm, 0.8 mm pitch, 0.30 mm balls
 - 100 TFBGA, 8.0 mm x 8.0 mm x 1.2 mm, 0.8 mm pitch, 0.45 mm balls
- Programmable power manager
- Automotive AEC-Q100 Grade 2 available (DA9063L-A)

Applications

- Portable industrial and medical devices
- TV dongle
- Supply for single-, dual- and quad-core application processors, for example the i.MX™ families
- eReaders
- Power supply for FPGAs
- Automotive infotainment/dashboard
- IoT devices

System PMIC for Mobile and Automotive Applications

Contents

| | |
|--|-----------|
| General Description | 1 |
| Key Features | 2 |
| Applications | 2 |
| Contents | 3 |
| 1 References | 7 |
| 2 Block Diagram | 7 |
| 3 Pinout | 8 |
| 4 Regulator Overview | 14 |
| 5 Electrical Characteristics | 16 |
| 5.1 Absolute Maximum Ratings | 16 |
| 5.2 Recommended Operating Conditions..... | 17 |
| 5.2.1 Power Derating Curves..... | 18 |
| 5.3 Typical Current Consumption | 20 |
| 5.4 Digital I/O Characteristics..... | 20 |
| 5.5 Watchdog | 22 |
| 5.6 HS 2-Wire Control Bus..... | 22 |
| 5.7 LDO Voltage Regulators | 23 |
| 5.7.1 LDO3..... | 23 |
| 5.7.2 LDO7..... | 26 |
| 5.7.3 LDO8..... | 28 |
| 5.7.4 LDO9..... | 30 |
| 5.7.5 LDO11..... | 32 |
| 5.7.6 LDOCORE | 34 |
| 5.8 DC/DC Buck Converters | 35 |
| 5.8.1 BUCKCORE1 and BUCKCORE2..... | 35 |
| 5.8.2 BUCKPRO | 39 |
| 5.8.3 BUCKMEM | 44 |
| 5.8.4 BUCKIO | 47 |
| 5.8.5 BUCKPERI | 49 |
| 5.8.6 Typical Characteristics..... | 51 |
| 5.9 General Purpose ADC | 54 |
| 5.10 Internal Oscillator | 55 |
| 5.11 POR, Reference Generation, and Voltage Supervision..... | 55 |
| 5.12 Thermal Supervision | 55 |
| 6 Functional Description | 57 |
| 6.1 Power Manager IO Ports..... | 58 |
| 6.1.1 On/Off Port (nONKEY)..... | 58 |
| 6.1.2 Wakeup Port (CHG_WAKE)..... | 59 |

System PMIC for Mobile and Automotive Applications

| | | |
|--------|--|----|
| 6.1.3 | Hardware Reset (nOFF, nSHUTDOWN, nONKEY, GPIO14, GPIO15, WATCHDOG) | 59 |
| 6.1.4 | Reset Output (nRESET) | 60 |
| 6.1.5 | System Enable (SYS_EN) | 60 |
| 6.1.6 | Power Enable (PWR_EN)..... | 60 |
| 6.1.7 | Power1 Enable (PWR1_EN) | 60 |
| 6.1.8 | GP_FB1, General Purpose Signal 1 (EXT_WAKEUP/READY) | 61 |
| 6.1.9 | GP_FB2, General Purpose Signal 2 (PWR_OK/KEEP_ACT)..... | 61 |
| 6.1.10 | GP_FB3, General Purpose Signal 3 (nVIB_BRAKE) | 61 |
| 6.1.11 | Supply Rail Fault (nVDD_FAULT) | 62 |
| 6.1.12 | Interrupt Request (nIRQ) | 62 |
| 6.1.13 | IO Supply Voltage (VDD_IO1 and VDD_IO2) | 62 |
| 6.2 | Operating Modes..... | 63 |
| 6.2.1 | ACTIVE Mode..... | 63 |
| 6.2.2 | POWERDOWN Mode..... | 63 |
| 6.2.3 | RESET Mode..... | 64 |
| 6.2.4 | DELIVERY Mode | 65 |
| 6.2.5 | NO-POWER Mode..... | 65 |
| 6.2.6 | Power Commander Mode..... | 65 |
| 6.3 | Start-Up from NO-POWER Mode | 67 |
| 6.3.1 | Power-On-Reset (nPOR)..... | 67 |
| 6.4 | Exiting Reset Mode and Application Wakeup | 67 |
| 6.4.1 | VDD_START | 67 |
| 6.4.2 | Wake-Up Events..... | 68 |
| 6.5 | Power Supply Sequencer..... | 70 |
| 6.5.1 | Powering Up | 70 |
| 6.5.2 | Power-Up Timing | 73 |
| 6.5.3 | Programmable Slot Delays | 74 |
| 6.5.4 | Powering Down..... | 74 |
| 6.5.5 | User Programmable Delay | 75 |
| 6.6 | System Monitor (Watchdog) | 77 |
| 6.7 | GPIO Extender | 77 |
| 6.8 | Control Interface..... | 81 |
| 6.9 | Voltage Regulators..... | 85 |
| 6.9.1 | Regulators Controlled by Software | 85 |
| 6.9.2 | Regulators Controlled by Hardware | 86 |
| 6.9.3 | Power Sequencer Control of LDOs | 86 |
| 6.9.4 | Dynamic Voltage Control | 87 |
| 6.9.5 | Pull-Down Resistor | 87 |
| 6.9.6 | Bypass Mode and Current Limit | 88 |
| 6.9.7 | LDO Supply from Buck Converter | 88 |
| 6.9.8 | LDO Sleep Mode for Reduced I _{OUT} | 88 |

System PMIC for Mobile and Automotive Applications

| | | |
|-------------------|--|------------|
| 6.9.9 | Vibration Motor Driver..... | 89 |
| 6.9.10 | Core Regulator LDOCORE..... | 89 |
| 6.10 | DC/DC Buck Converters | 90 |
| 6.10.1 | BUCKCORE1, BUCKCORE2, and BUCKPRO | 92 |
| 6.10.2 | BUCKPRO in DDR Memory Bus Termination Mode | 93 |
| 6.10.3 | BUCKMEM and BUCKIO in Merged Mode | 94 |
| 6.11 | General Purpose ADC | 95 |
| 6.11.1 | ADC Overview | 95 |
| 6.11.2 | ADC Input MUX | 95 |
| 6.11.3 | Manual Conversion Mode..... | 96 |
| 6.11.4 | Automatic Measurements Scheduler..... | 96 |
| 6.11.5 | Fixed Threshold Comparator..... | 100 |
| 6.12 | Adjustable Frequency Internal Oscillator | 101 |
| 6.13 | Reference Voltage Generation: VREF, VLNREF | 101 |
| 6.14 | Thermal Supervision | 101 |
| 6.15 | Main System Rail Voltage Supervision | 101 |
| 7 | Register Map..... | 103 |
| 8 | Definitions..... | 116 |
| 8.1 | Power Dissipation and Thermal Design..... | 116 |
| 8.2 | Regulator Parameter - Dropout Voltage | 117 |
| 8.3 | Regulator Parameter - Power Supply Rejection | 117 |
| 8.4 | Regulator Parameter - Line Regulation | 117 |
| 8.5 | Regulator Parameter - Load Regulation | 118 |
| 9 | Package Information | 119 |
| 9.1 | Package Outlines | 119 |
| 9.2 | Package Marking | 121 |
| 9.3 | Moisture Sensitivity Level..... | 121 |
| 10 | Ordering Information | 122 |
| 10.1 | Variants Ordering Information | 122 |
| 11 | Application Information | 123 |
| 11.1 | Capacitor Selection | 123 |
| 11.2 | Inductor Selection | 124 |
| 11.3 | Resistors 125 | |
| 12 | Layout Guidelines | 126 |
| 12.1 | General Recommendations | 126 |
| 12.2 | LDOs and Switched Mode Supplies | 126 |
| 12.3 | Thermal Connection, Land Pad, and Stencil Design | 126 |
| Appendix A | Register Descriptions | 127 |
| A.1 | Register Page Control..... | 127 |
| A.2 | Register Page 0 | 127 |

System PMIC for Mobile and Automotive Applications

| | | |
|-------|---|-----|
| A.2.1 | Power Manager Control and Monitoring..... | 127 |
| A.2.2 | GPIO Control | 136 |
| A.2.3 | Regulator Control..... | 143 |
| A.2.4 | GPADC | 151 |
| A.2.5 | ADC Results | 152 |
| A.3 | Register Page 1 | 154 |
| A.3.1 | Power Sequencer | 154 |
| A.3.2 | Regulator Settings | 160 |
| A.3.3 | High Power GPO PWM | 184 |
| A.3.4 | GPADC Thresholds | 185 |
| A.4 | Register Page 2 | 188 |
| A.4.1 | OTP..... | 188 |
| A.4.2 | Customer Trim and Configuration | 189 |
| A.5 | Register Page 3 | 202 |

System PMIC for Mobile and Automotive Applications

1 References

Dialog Semiconductor technical documentation is available on the web site: [Power Management ICs \(PMICs\)](#).

- [1] AN-PM-068, Application Note, VBBAT Current in RTC or DELIVERY Modes, Dialog Semiconductor.
- [2] AN-PM-024, Application Note, DA9063 Voltage Monitoring, Dialog Semiconductor.
- [3] AN-PM-010, Application Note, PCB Layout Guidelines, Dialog Semiconductor.

2 Block Diagram

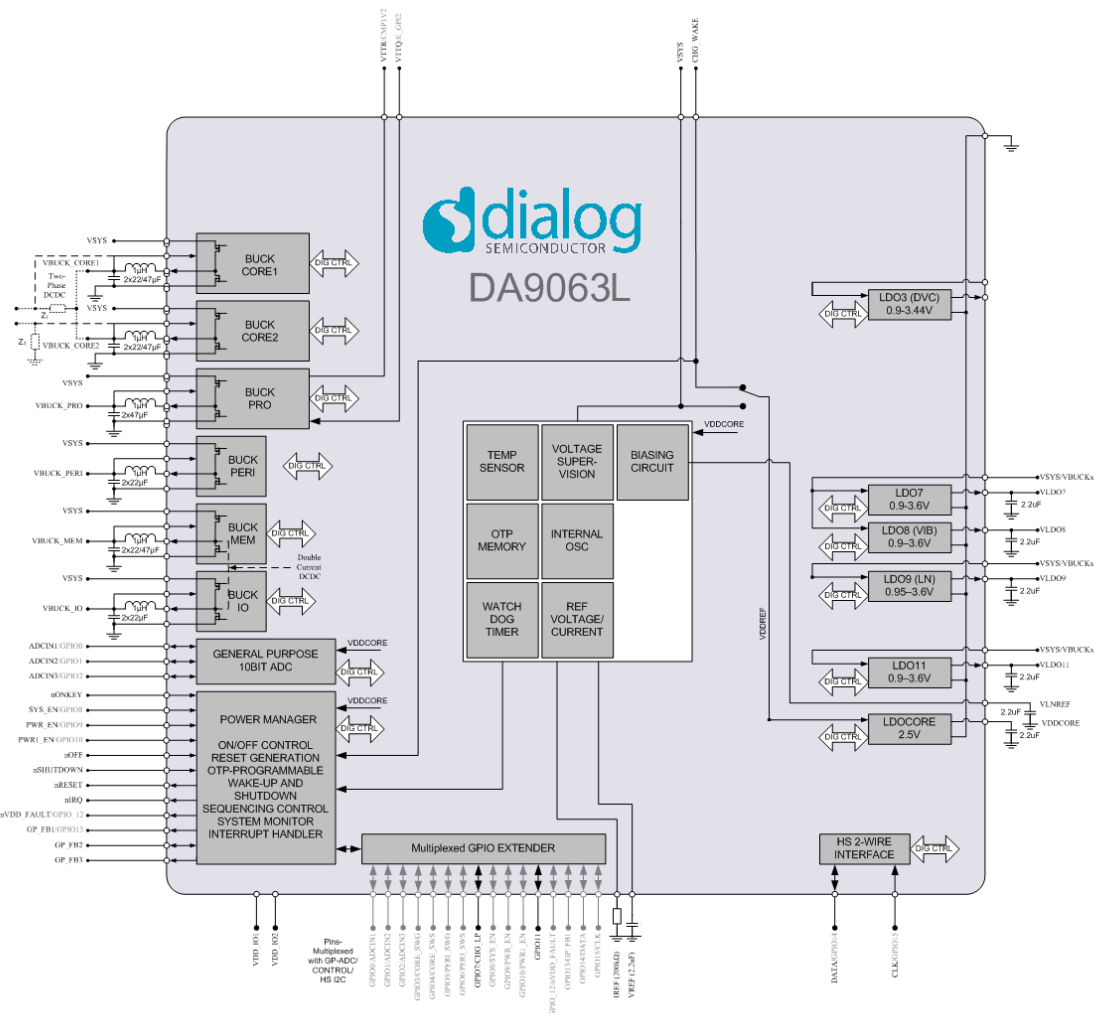

Figure 1: Block Diagram

System PMIC for Mobile and Automotive Applications

3 Pinout

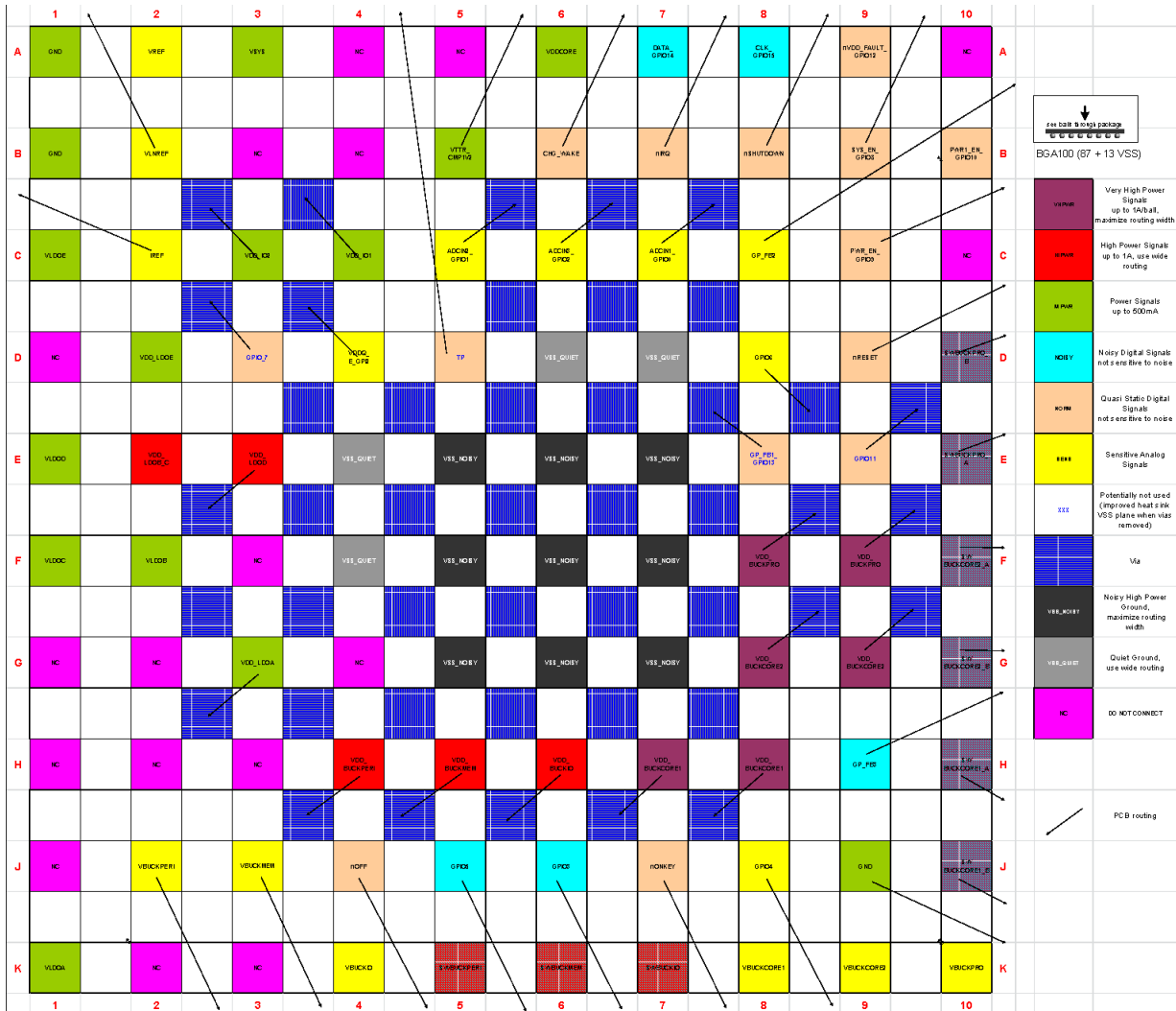

Figure 2: Connection Diagram

Table 1: Pin Type Definition

| Pin Type | Description | Pin Type | Description |
|----------|----------------------|----------|---------------------|
| DI | Digital input | AI | Analog input |
| DO | Digital output | AO | Analog output |
| DIO | Digital input/output | AIO | Analog input/output |
| PWR | Power supply | GND | Ground connection |

System PMIC for Mobile and Automotive Applications

Table 2: Pin Description

| Pin | Pin name | Alternate Function | Type (Table 1) | Description |
|----------------------|------------|--------------------|----------------|---|
| Power Manager | | | | |
| A9 | nVDD_FAULT | GPIO12 | DO/DIO | Indication for low supply voltage / GPIO12 / VDD_MON controlled GPO |
| B6 | CHG_WAKE | | DI/PWR | Wakeup signal from companion charger to trigger a start-up and temporary supply voltage for PMIC (VBUS_PROT in case of an inserted supply until charger Buck provides power to V _{sys}). Connect to GND if not used. |
| B7 | nIRQ | | DO | IRQ line for host |
| B8 | nSHUTDOWN | | DI | Active-low input from switch or host to initiate shutdown |
| B9 | SYS_EN | GPIO8 | DI/DIO | Hardware enable of power domain SYSTEM/GPIO8 |
| B10 | PWR1_EN | GPIO10 | DI/DIO | Hardware enable of power domain POWER1/GPIO10 with high power output / input for power sequencer WAIT ID |
| C3 | VDD_IO2 | | PWR | Alternate supply I/O voltage |
| C4 | VDD_IO1 | | PWR | First supply I/O voltage rail |
| C8 | GP_FB2 | | DO/DI | PWR_OK status indicator: all supervised regulators are in-range / HW input for watchdog supervision / dual-phase BUCKCORE voltage sense at output capacitor |
| C9 | PWR_EN | GPIO9 | DI/DIO | Hardware enable of power domain power / sequencer controlled GPO |
| D3 | GPIO7 | | DIO | Sequencer controlled GPO |
| D5 | TP | | DIO | Test pin: enables power commander boot mode and supply pin for OTP fusing voltage |
| D9 | nRESET | | DO | Active low reset for host |
| E8 | GP_FB1 | GPIO13 | DO/DIO | Status indication for host of a valid wakeup event (EXT_WAKEUP) / indicator for on-going power mode transition (READY) / GPIO13, regulator HW control |
| E9 | GPIO11 | | DIO | GPIO11 with high power output and blinking feature |
| H9 | GP_FB3 | | DI | nVIB_BREAK control signal for vibration motor driver (LDO8) |
| J4 | nOFF | | DI | Active-low input from error indication line to initiate fast emergency shutdown |
| J7 | nONKEY | | DI | On/off key with optional long press shutdown |

System PMIC for Mobile and Automotive Applications

| Pin | Pin name | Alternate Function | Type (Table 1) | Description |
|---------------------------|------------|--------------------|----------------|--|
| 2-Wire Interface | | | | |
| A4 | | | | |
| A5 | | | | Connect to ground |
| A7 | DATA | GPIO14 | DIO | HS 2-WIRE data / GPIO14 (optional reset if long press in parallel with GPI15) with high power output and blinking feature |
| A8 | CLK | GPIO15 | DI | HS 2-WIRE clock / GPIO15 (optional reset if long press in parallel with GPI14) with high power output and blinking feature |
| B3 | | | | Connect to ground |
| B4 | | | | Connect to ground |
| Voltage Regulators | | | | |
| A3 | VSYS | | PWR | Supply voltage for PMIC and input for voltage supervision (decouple with 1.0 μ F) |
| A6 | VDDCORE | | AO | Regulated supply for internal circuitry (2.2 V/2.5 V) (decouple with 2.2 μ F) |
| C1 | VLDO11 | | AO | Output voltage from LDO11 |
| D1 | | | | |
| D2 | VDD_LDO11 | | PWR | Supply voltage for LDO11 |
| E1 | VLDO9 | | AO | Output voltage from LDO9 |
| E2 | VDD_LDO7_8 | | PWR | Supply voltage for LDO7 and LDO8 |
| E3 | VDD_LDO9 | | PWR | Supply voltage for LDO9 |
| F1 | VLDO8 | | AO | Output voltage from LDO8 |
| F2 | VLDO7 | | AO | Output voltage from LDO7 |
| F3 | | | | Connect to ground |
| G1 | | | | |
| G2 | | | | Connect to ground |
| G3 | VDD_LDO3 | | PWR | Supply voltage for LDO3 |
| G4 | | | | Connect to ground |
| H1 | | | | |
| H2 | | | | Connect to ground |
| H3 | | | | Connect to ground |
| J1 | | | | |
| K1 | VLDO3 | | AO | Output voltage from LDO3 |

System PMIC for Mobile and Automotive Applications

| Pin | Pin name | Alternate Function | Type (Table 1) | Description |
|-----|----------|--------------------|----------------|-------------|
| K2 | | | | |
| K3 | | | | |

System PMIC for Mobile and Automotive Applications

| Pin | Pin name | Alternate Function | Type (Table 1) | Description |
|------------------------------|---------------|--------------------|----------------|---|
| DC/DC Buck Converters | | | | |
| A1 | | | | Connect to ground |
| A2 | VREF | | AIO | Filter node for internal reference voltage (decouple with 0.22 μ F) |
| A10 | | | | |
| B1 | | | | Connect to ground |
| B2 | VLNREF | | | Filter node for LN (low noise) (decouple with 0.22 μ F) |
| B5 | VTTR | CMP1V2 | AO/DO | Memory bus termination reference voltage (50 % of VDDQ), COMP1V2 controlled GPO |
| C2 | IREF | | AO | Connection for bias setting (configure with high precision 200 k Ω resistor) |
| C5 | ADCIN2 | GPIO1 | AI/DIO | Connection to GPADC channel 2 with 1.2 V HW comparator IRQ/GPIO1, regulator HW control |
| C6 | ADCIN3 | GPIO2 | AI/DIO | Connection to GPADC channel 3/GPIO2, regulator HW control |
| C7 | ADCIN1 | GPIO0 | AI/DIO | Connection to GPADC auto channel 1 with threshold IRQ and resistor measurement option/GPIO0 |
| C10 | | | | |
| D4 | VDDQ | E_GPI2 | AI/DO | BUCKPRO target voltage sense port / state of E_GPI2 controlled GPO |
| D8 | PERI_SWS | GPIO6 | AI/DIO | BUCKPERI sense node/GPIO6 |
| D10 | SWBUCKPRO_B | | AO | Switching node for BUCKPRO (full-current) |
| E10 | SWBUCKPRO_A | | AO | Switching node for BUCKPRO (half-current) |
| F8, F9 | VDD_BUCKPRO | | PWR | Supply voltage for buck To be connected to VSYS |
| F10 | SWBUCKCORE2_A | | AO | Switching node for BUCKCORE2 (half-current) |
| G8, G9 | VDD_BUCKCORE2 | | PWR | Supply voltage for buck To be connected to VSYS |
| G10 | SWBUCKCORE2_B | | AO | Switching node for BUCKCORE2 (full-current) |
| H4 | VDD_BUCKPERI | | PWR | Supply voltage for buck To be connected to VSYS |
| H5 | VDD_BUCKMEM | | PWR | Supply voltage for buck To be connected to VSYS |

System PMIC for Mobile and Automotive Applications

| Pin | Pin name | Alternate Function | Type (Table 1) | Description |
|---|---------------|--------------------|----------------|---|
| H6 | VDD_BUCKIO | | PWR | Supply voltage for buck To be connected to VSYS |
| H7, H8 | VDD_BUCKCORE1 | | PWR | Supply voltage for buck To be connected to VSYS |
| H10 | SWBUCKCORE1_A | | AO | Switching node for BUCKCORE1 (half-current) |
| J2 | VBUCKPERI | | AI | Sense node for BUCKPERI |
| J3 | VBUCKMEM | | AI | Sense node for DC/DC BUCKMEM |
| J5 | GPIO5 | | DIO | GPIO5 |
| J6 | GPIO3 | | DIO | GPIO3 |
| J8 | CORE_SWS | GPIO4 | AI/DIO | BUCKCORE sense node from output capacitor of dual-phase BUCKCORE1/2 connection of internal switch to the output of GPIO4 |
| J10 | SWBUCKCORE1_B | | AO | Switching node for BUCKCORE1 (full-current) |
| K4 | VBUCKIO | | AI | Sense node for BUCKIO |
| K5 | SWBUCKPERI | | AO | Switching node for BUCKPERI |
| K6 | SWBUCKMEM | | AO | Switching node for BUCKMEM |
| K7 | SWBUCKIO | | AO | Switching node for BUCKIO To be connected to SWBUCKMEM for buck merge |
| K8 | VBUCKCORE1 | | AI | Sense node for BUCKCORE1 |
| K9 | VBUCKCORE2 | | AI | Sense node for BUCKCORE2 |
| K10 | VBUCKPRO | | AI | Sense node for BUCKPRO |
| J9 | | | | Connect to ground |
| VSS | | | | |
| D6 to D7, E4, F4 | GND | | GND | VSS_LDO, VSS_ADC, VSS_CORE, VSUB |
| E5 to E7, F5 to F7, G5 to G7 | GND | | GND | VSS_BUCKCORE1_A, VSS_BUCKCORE1_B, VSS_BUCKCORE2_A, VSS_BUCKCORE2_B, VSS_BUCK_PRO_A, VSS_BUCK_PRO_B, VSS_BUCK_IO, VSS_BUCK_MEM, VSS_BUCK_PERI |

System PMIC for Mobile and Automotive Applications

4 Regulator Overview

Table 3: Regulators

| Regulator | Supplied Pins | Supplied Voltage (V) | Supplied Max. Current (mA) | External Component | Notes |
|-----------|---------------|----------------------|---|--|--|
| BUCKCORE1 | VBUCKCORE1 | 0.3 to 1.57 | 1250/2500 (full-current mode) Note 1 | 1.0 μ H/ 44 μ F / 88 μ F | <ul style="list-style-type: none"> GPIO and host interface-controlled DVC with variable slew rate (10 mV in [0.5, 1.0, 2.0, 4.0] μs) 10 mV steps < 0.7 V PFM mode only 2500 mA in full-current mode (double pass device and current limit) Provides dual-phase buck with up to 5 A if combined with BUCKCORE2 |
| BUCKCORE2 | VBUCKCORE2 | 0.3 to 1.57 | 1250/2500 (full-current mode) Note 1 | 1.0 μ H/ 44/88 μ F | <ul style="list-style-type: none"> GPIO and host interface-controlled DVC with variable slew rate (10 mV in [0.5/1.0/2.0/4.0] μs) 10 mV steps < 0.7 V PFM mode only 2500 mA in full-current mode (double pass device and current limit) Provides dual-phase Buck if combined with BUCKCORE1 |
| BUCKPRO | VBUCKPRO | 0.53 to 1.80 | 1250/2500 (full-current mode) Note 1 | 1.0 μ H/ 44/88 μ F | <ul style="list-style-type: none"> GPIO and host interface-controlled DVC with variable slew rate, (10 mV in [0.5/1.0/2.0/4.0] μs) 10 mV steps and VTT regulator mode < 0.7 V PFM mode only 2500 mA in full-current mode (double pass device and current limit) |
| BUCKMEM | VBUCKMEM | 0.8 to 3.34 | 1500 Note 1 | 1.0 μ H/ 44 μ F | <ul style="list-style-type: none"> GPIO and host interface-controlled DVC with variable slew rate (10 mV in [0.5/1.0/2.0/4.0] μs) 20 mV steps Can be merged with BUCK_IO towards single |

System PMIC for Mobile and Automotive Applications

| Regulator | Supplied Pins | Supplied Voltage (V) | Supplied Max. Current (mA) | External Component | Notes |
|-----------|----------------------|------------------------|--------------------------------|----------------------------|---|
| | | | | | buck with up to 3 A output current |
| BUCKIO | VBUCKIO | 0.8 to 3.34 | 1500 Note 1 | 1.0 μ H/ 44 μ F | <ul style="list-style-type: none"> GPIO and host interface-controlled DVC with variable slew rate (10 mV in [0.5/1.0/2.0/4.0] μs) 20 mV steps, can be merged with BUCK_MEM |
| BUCKPERI | VBUCKPERI | 0.8 to 3.34 | 1500 Note 1 | 1.0 μ H/ 44 μ F | <ul style="list-style-type: none"> GPIO and host interface-controlled DVC with variable slew rate (10 mV in [0.5/1.0/2.0/4.0] μs) 20 mV steps |
| LDO3 | VLDO3 | 0.9 to 3.44 | 200 | 2.2 μ F | <ul style="list-style-type: none"> Bypass mode GPIO and host interface-controlled DVC with variable slew rate (10 mV in [0.5/1.0/2.0/4.0] μs) 20 mV steps |
| LDO7 | VLDO7 | 0.9 to 3.6 | 200 | 2.2 μ F | <ul style="list-style-type: none"> Bypass mode 50 mV steps Common supply with LDO8 |
| LDO8 | VLDO8 | 0.9 to 3.6 | 200 | 2.2 μ F | <ul style="list-style-type: none"> Bypass and switching vibration motor driver mode 50 mV steps Common supply with LDO7 |
| LDO9 | VLDO9 | 0.95 to 3.6 | 200 | 2.2 μ F | <ul style="list-style-type: none"> Low noise 50 mV steps OTP trimmed |
| LDO11 | VLDO11 | 0.9 to 3.6 | 300 | 2.2 μ F | <ul style="list-style-type: none"> Bypass mode 50 mV steps |
| LDOCORE | Internal PMIC supply | 2.5 \pm 2 % accuracy | 4 | 2.2 μ F | <ul style="list-style-type: none"> Internal LDO OTP trimmed |

Note 1 For short durations to meet peak current requirements I_{OUT} can be operated at up to 20 % higher than the specified maximum operating condition. The part should not be operated in this mode for extended periods and is not guaranteed for continuous operation.

System PMIC for Mobile and Automotive Applications

5 Electrical Characteristics

5.1 Absolute Maximum Ratings

Table 4 lists the absolute maximum ratings of the device. Exceeding these ratings may cause permanent damage to the device. Device functionality is only guaranteed under the conditions listed in Sections 5.1 and 5.2. Operating the device in conditions exceeding those listed in Table 5 but compliant with the absolute maximum ratings listed in Table 4, for extended periods of time may affect device reliability.

Table 4: Absolute Maximum Ratings

| Parameter | Description | Conditions | Min | Typ | Max | Unit |
|---|---|----------------|------|-----|--------------------------|------|
| T _{STG} | Storage temperature | | -65 | | +150 | °C |
| T _J | Junction temperature | Note 1 | -40 | | +150 | °C |
| V _{SYS} , V _{CHG_WAKE} | Supply voltage | | -0.3 | | 6.0 | V |
| V _{TP} | | Note 3 | -0.3 | | 8.0 | V |
| All other pins | | Note 2 | -0.3 | | V _{DDREF} + 0.3 | V |
| V _{ESD_HBM} | ESD protection - Human Body Model (HBM) | | 2000 | | | V |
| V _{ESD_CDM} | ESD protection - Charged Device Model (CDM) | Corner pins | 750 | | | V |
| | | All other pins | 500 | | | |

Note 1 See Section 5.12 and Section 6.14.

Note 2 Maximum V_{DDREF} = 6 V. An internal node V_{DDREF} is defined as the higher rail of CHG_WAKE and V_{SYS}.

Note 3 Voltage on TP pin should be 0 V except during in-circuit programming.

System PMIC for Mobile and Automotive Applications

5.2 Recommended Operating Conditions

All voltages are referenced to VSS unless otherwise stated. Currents flowing into DA9063L are deemed positive; currents flowing out are deemed negative. All parameters are valid over the recommended temperature range and power supply range unless otherwise stated. Please note that the power dissipation must be limited to avoid overheating of DA9063L.

Table 5: Recommended Operating Conditions

| Parameter | Description | Conditions | Min | Typ | Max | Unit |
|--|--|--|------|-------|------|------|
| T _J | Junction temperature | | -40 | | +125 | °C |
| V _{SYS} , V _{CHG_WAKE} | Supply voltage | | 0 | | 5.5 | V |
| V _{DD_IO1/2} | Supply voltage IO | Note 1 | 1.2 | | 3.6 | V |
| V _{TP} | TP programming supply | Note 5 | 7.25 | 7.5 | 7.75 | V |
| I _{OUT} | BUCKCORE1, BUCKCORE2, BUCKPRO | Note 2 | | | 2500 | mA |
| I _{OUT} | BUCKMEM, BUCKIO, BUCKPERI | Note 2 | | | 1500 | mA |
| R _{θ_JA} | Thermal resistance junction to ambient | 100 VFBGA package Note 3 | | 27.7 | | °C/W |
| | | 100 TFBGA package Note 4 | | 17.2 | | °C/W |
| R _{θ_JB} | Thermal resistance junction to Board | 100 TFBGA package Note 4 | | 11.1 | | °C/W |
| R _{θ_JC} | Thermal resistance junction to case | 100 TFBGA package Note 4 | | 13.29 | | °C/W |
| P _D | Maximum power dissipation, see Section 5.2.1 | 100 VFBGA Derating factor above T _A = 70 °C: 36.1 mW/°C (1/θ _{JA}) | 2000 | | | mW |
| | | 100 TFBGA Derating factor above T _A = 70 °C: 58.1 mW/°C (1/θ _{JA}) | 3770 | | | mW |

Note 1 V_{DDIO1/2} must not exceed V_{DDREF}.

Note 2 For short durations to meet peak current requirements I_{OUT} can be operated at up to 20 % higher than the specified maximum operating condition. The part should not be operated in this mode for extended periods and is not guaranteed for continuous operation.

Note 3 Obtained from package thermal simulations, JEDEC 2S2P four layer board (76.2 mm x 114 mm x 1.6 mm), 70 μm (2 oz) copper thickness power planes, 35 μm (1 oz) copper thickness signal layer traces, natural convection (still air), see Section 9.1.

Note 4 Obtained from package thermal simulations, JEDEC 2S2P four layer board (101.6 mm x 114.3 mm x 1.6 mm), 70 μm (2 oz) copper thickness power planes, 35 μm (1 oz) copper thickness signal layer traces, natural convection (still air), see Section 9.1.

System PMIC for Mobile and Automotive Applications

Note 5 Voltage on TP pin should be 0 V except during in-circuit programming.

5.2.1 Power Derating Curves

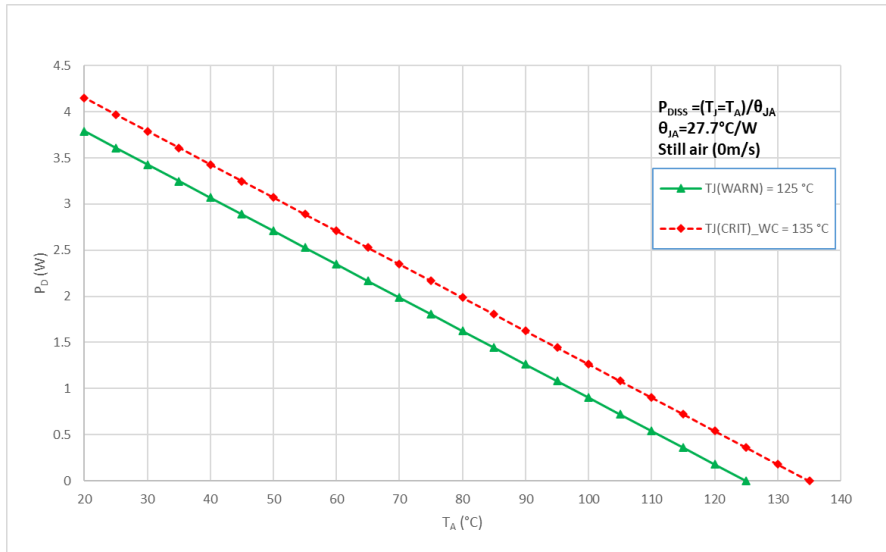

Figure 3: 100 VFBGA Power Derating Curve

Table 6: Typical Temperatures

| | T _A = 70 °C | T _A = 85 °C | T _A = 105 °C |
|------------------------|-------------------------|-------------------------|--------------------------|
| T _{J_WARN} | P _D = 1.99 W | P _D = 1.44 W | P _D = 0.72 W |
| T _{J_CRIT_WC} | P _D = 2.35 W | P _D = 1.81 W | P _D = 1.083 W |

System PMIC for Mobile and Automotive Applications

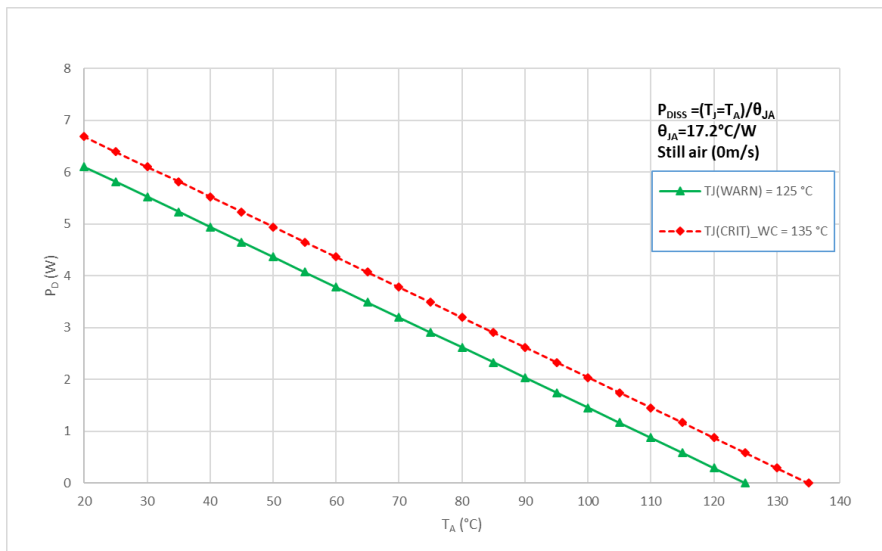

Figure 4:100 TFBGA Power Derating Curve

Table 7: Typical Temperatures

| | $T_A = 70^\circ\text{C}$ | $T_A = 85^\circ\text{C}$ | $T_A = 105^\circ\text{C}$ |
|---------------|--------------------------|--------------------------|---------------------------|
| T_{J_WARN} | $P_D = 3.19\text{ W}$ | $P_D = 2.32\text{ W}$ | $P_D = 1.16\text{ W}$ |
| T_{J_CRIT} | $P_D = 3.77\text{ W}$ | $P_D = 2.9\text{ W}$ | $P_D = 1.74\text{ W}$ |

System PMIC for Mobile and Automotive Applications

5.3 Typical Current Consumption

Table 8: Typical Current Consumption

| Operating Mode | Conditions (Note 1) | Battery | Unit |
|----------------------------|--|---------|---------------|
| NO-POWER mode (POR) | $2.4\text{ V} > V_{DDREF} > 1.5\text{ V}$ | 16 | μA |
| DELIVERY mode | $V_{DDREF} > 1.5\text{ V}$ | 1.8 | μA |
| RESET mode | $V_{DDREF} > 2.2\text{ V}$, supplies off (except LDOCORE), pulsed mode | 18 | μA |
| LOW-POWER mode | $V_{SYS} > V_{DD_FAULT_LOWER}$, supplies off (except LDOCORE), all blocks in POWERDOWN mode, pulsed mode with limited parametric compliance | 12 | μA |
| POWERDOWN mode (Hibernate) | $V_{SYS} > V_{DD_FAULT_LOWER}$, supplies off (except LDOCORE), all blocks in POWERDOWN mode | 28 | μA |
| POWERDOWN mode (Standby) | BUCKCORE, LDOCORE, and LD03, 8, 11 enabled, GPIO unit on (Note 2) | 60 | μA |
| ACTIVE mode | All supplies, GPIO, and GPADC off | 200 | μA |
| ACTIVE mode | All supplies, GPIO, and GPADC on | 320 | μA |

Note 1 nONKEY/CHG_WAKE/ V_{DDREF} detection circuit is enabled in all modes.

Note 2 Regulators are running in sleep mode.

5.4 Digital I/O Characteristics

Table 9: Digital I/O Electrical Characteristics, $T_J = -40\text{ }^\circ\text{C}$ to $+125\text{ }^\circ\text{C}$

| Parameter | Description | Conditions | Min | Typ | Max | Unit |
|-----------|---|---|-------------------------|-----|-------------------------|------|
| V_{IH} | GPIO to GPI15, CLK, DATA, nOFF, nSHUTDOWN SYS_EN, PWR_EN, PWR1_EN Input High Voltage | VDDCORE mode | 1.0 | | V_{SYS} | V |
| | | VDD_IO2 mode | $0.7 \cdot V_{DD_IO2}$ | | V_{SYS} | |
| V_{IL} | GPIO to GPI15, CLK, DATA, nOFF, nSHUTDOWN SYS_EN, PWR_EN, PWR1_EN Input Low Voltage | VDDCORE mode | -0.3 | | 0.4 | V |
| | | VDD_IO2 mode | -0.3 | | $0.3 \cdot V_{DD_IO2}$ | |
| V_{IH} | nONKEY, CHG_WAKE Input High Voltage | | 1.0 | | V_{SYS} | V |
| V_{IL} | nONKEY, CHG_WAKE Input Low Voltage | | -0.3 | | 0.4 | V |
| V_{OH} | GPO0 to GPO15, nVDD_FAULT, nRESET, nIRQ, E_GPI_2, COMP1V2 | $I_{OUT} = 1\text{ mA}$ VDD_IO1 mode $\geq 1.5\text{ V}$ | $0.8 \cdot V_{DD_IO1}$ | | | V |

System PMIC for Mobile and Automotive Applications

| Parameter | Description | Conditions | Min | Typ | Max | Unit |
|-----------|--|--|-------------------------|-----|-------------|------------|
| | Output High Voltage | $I_{OUT} = 1 \text{ mA}$ VDD_IO2 mode $\geq 1.5 \text{ V}$ | $0.8 \cdot V_{DD_IO2}$ | | | |
| V_{OH} | GPO1, 3 to 6, 10, and 12 to 15, DATA, nRESET, nIRQ, PWR_OK (open drain mode) Output High Voltage | Open drain | | | V_{DDREF} | V |
| V_{OL} | GPO0 to GPO15, nVDD_FAULT, nRESET (Note 1), nIRQ (Note 1), PWR_OK, E_GPI_2, COMP1V2, Output Low Voltage | $I_{OUT} = 1 \text{ mA}$ | | | 0.3 | V |
| C_{IN} | CLK, DATA Input capacitance | | | | 10 | pF |
| | Sink current capability GPO 10, 11, 14, 15 | $V_{GPIO} = 0.5 \text{ V}$ Note 2 | | 11 | | mA |
| | Source current capability GPO 10, 11, 14, 15 | $V_{GPIO} = 0.8 \cdot V_{DD_IO1/2}$ Note 2 | | -4 | | mA |
| | Sink current capability GPO 0 to 9, 12, 13 | $V_{GPIO} = 0.3 \text{ V}$ | | 1 | | mA |
| | Source current capability GPO 0 to 9, 12, 13 | $V_{GPIO} = 0.8 \cdot V_{DD_IO1/2}$ Note 3 | | -1 | | mA |
| | GPI pull-down resistor | | 50 | 100 | 250 | k Ω |
| | GPO pull-up resistor Note 4 | $V_{DD_IO1/2} = 1.5 \text{ V}$ | 60 | 180 | 310 | k Ω |
| | | $V_{DD_IO1/2} = 1.8 \text{ V}$ | 45 | 120 | 190 | |
| | | $V_{DD_IO1/2} = 3.3 \text{ V}$ | 20 | 40 | 60 | |

Note 1 Electrical characteristics are guaranteed down to $V_{DDREF} = 2.0 \text{ V}$ (VPOR_LOWER). For lower voltages the port continues operating with reduced performance.

Note 2 At low V_{DDREF} values and high temperatures, the sink current capability is reduced.

Note 3 For $V_{DD_IO1/2} < 1.5 \text{ V}$ the source current capability is reduced.

Note 4 $V(PAD) = 0 \text{ V}$.

System PMIC for Mobile and Automotive Applications

5.5 Watchdog

Table 10: Watchdog, $T_J = -40\text{ }^\circ\text{C}$ to $+125\text{ }^\circ\text{C}$

| Parameter | Description | Conditions | Min | Typ | Max | Unit |
|---------------|-----------------------|----------------------------|-----|-----|------|------|
| T_{WD_MIN} | Minimum Watchdog time | External 32 kHz oscillator | | | 0.11 | s |
| | | Internal 25 kHz oscillator | | | 0.2 | s |
| T_{WD_MAX} | Maximum Watchdog time | External 32 kHz oscillator | 2 | | | s |
| | | Internal 25 kHz oscillator | 2.5 | | | |

5.6 HS 2-Wire Control Bus

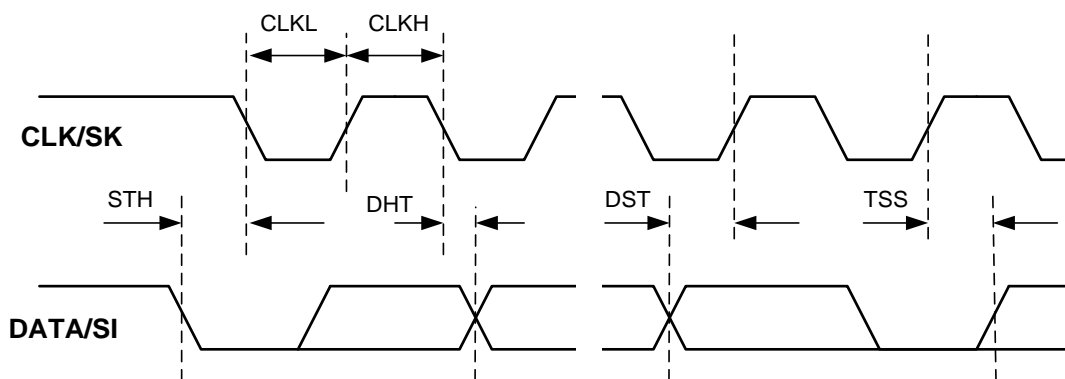

Figure 5: 2-Wire Bus Timing

Table 11: HS 2-Wire Control Bus Electrical Characteristics, $T_J = -40\text{ }^\circ\text{C}$ to $+125\text{ }^\circ\text{C}$

| Parameter | Description | Conditions | Min | Typ | Max | Unit |
|---------------------------------|-------------------------------|---------------------|------|-----|------|---------------|
| | Bus free time STOP to START | | 0.5 | | | μs |
| C_B | Bus line capacitive load | | | | 150 | pF |
| Standard/Fast/Fast+ Mode | | | | | | |
| | CLK clock frequency | Note 1 | 0 | | 1000 | kHz |
| | Bus free time STOP to START | | 0.5 | | | μs |
| | Start condition set-up time | | 0.26 | | | μs |
| STH | Start condition hold time | | 0.26 | | | μs |
| CLKL | CLK low time | | 0.5 | | | μs |
| CLKH | CLK high time | | 0.26 | | | μs |
| | 2-WIRE CLK and DATA rise time | (input requirement) | | | 1000 | ns |
| | 2-WIRE CLK and DATA fall time | (input requirement) | | | 300 | ns |
| DST | Data set-up time | | 50 | | | ns |

System PMIC for Mobile and Automotive Applications

| Parameter | Description | Conditions | Min | Typ | Max | Unit |
|------------------------|-------------------------------------|--|------|-----|------|------|
| DHT | Data hold-time | | 0 | | | ns |
| | Data valid time | | | | 0.45 | μs |
| | Data valid time acknowledge | | | | 0.45 | μs |
| TSS | Stop condition set-up time | | 0.26 | | | μs |
| High Speed Mode | | | | | | |
| | CLK clock frequency | Requires VDDIO ≥ 1.8 V Note 1 | 0 | | 3400 | kHz |
| | Start condition set-up time | | 160 | | | ns |
| STH | Start condition hold time | | 160 | | | ns |
| CLKL | CLK low time | | 160 | | | ns |
| CLKH | CLK high time | | 60 | | | ns |
| | 2-WIRE CLKH and SDAH rise/fall time | Input requirement | | | 160 | ns |
| DST | Data set-up time | | 10 | | | ns |
| DHT | Data hold-time | | 0 | | | ns |
| TSS | Stop condition set-up time | | 160 | | | ns |

Note 1 Minimum clock frequency is 10 kHz if 2WIRE_TO is enabled

5.7 LDO Voltage Regulators

5.7.1 LDO3

Table 12: LDO3, T_J = -40 °C to +125 °C

| Parameter | Description | Conditions | Min | Typ | Max | Unit |
|----------------------------------|---|--|---------------------------------|------------------------|------|------|
| V _{DD} | Input voltage | V _{DD} = V _{SYS} | 2.8 | | 5.5 | V |
| | | If supplied from buck | (1.5) Note 1 | | | |
| V _{LDO} | Output voltage | | 0.9 | Note 2 | 3.44 | V |
| V _{LDO_ACC} | Output accuracy Note 3 | V _{DD} = V _{SYS} = 2.8V to 5.5 V I _{OUT} = 200 mA Including static line/load regulation | -3 | | +3 | % |
| C _{OUT} | Stabilization capacitor | Including voltage and temperature coefficient at configured VLDO3 | -55% | 2.2 | +35% | μF |
| R _{COU_T_ESR} | Output capacitor ESR | f > 1 MHz including wiring parasitics | 0 | | 300 | mΩ |
| I _{OUT_MAX} | Output current | V _{DD} = V _{SYS} = 2.8 V to 5.5 V | 200 | | | mA |

System PMIC for Mobile and Automotive Applications

| Parameter | Description | Conditions | Min | Typ | Max | Unit |
|--------------------------------|-------------------------------------|---|-----|--------------------------------------|------------|-------------------|
| I _{SHORT} | Short circuit current | | | 400 | | mA |
| I _{SLEEP} | Maximum forced sleep mode current | V _{DD} ≥ 1.8 V | 20 | | | mA |
| V _{DROPOUT} | Dropout voltage | V _{DD} = V _{SYS} > 2.8 V I _{OUT} = 100 mA (V _{DD} = 1.5 V, I _{OUT} = I _{MAX} /3) | | 100 | 150 | mV |
| V _{S_LINE} | Static line regulation | V _{DD} = V _{SYS} = 3.0 V to 5.5 V I _{OUT} = 200 mA | | 1 | 5 | mV |
| V _{S_LOAD} | Static load regulation | I _{OUT} = 1 mA to 200 mA | | 5 | 10 | mV |
| V _{TR_LINE} | Line transient response | V _{DD} = V _{SYS} = 3.0 V to 3.6 V I _{OUT} = 100 mA tr = tf = 10 μs | | 5 | 10 | mV |
| V _{TR_LOAD} | Load transient response | V _{DD} = 3.6 V I _{OUT} = 1 mA to 200 mA tr = tf = 1 μs | | 30 | 50 | mV |
| PSRR Note 4 | PSRR | f = 10 Hz to 10 kHz, RT V _{DD} = 3.6 V, I _{OUT} = I _{MAX} /2 V _{DD} - V _{LDO} ≥ 0.6 V | 50 | 60 | | dB |
| N | Output noise | V _{DD} = V _{SYS} = 3.6 V, V _{LDO} = 2.8 V I _{OUT} = 5 mA to I _{MAX} f = 10 Hz to 100 kHz RT | | 70 | | μV _{rms} |
| I _{Q_ON} | Quiescent current in ON mode | Note 5 | | 9 + 0.45% of I _{OUT} | | μA |
| I _{Q_SLEEP} | Quiescent current forced sleep mode | | | 1.5 + 1.0% of I _{OUT} | | μA |
| I _{Q_OFF} | Quiescent current OFF mode | | | 1 | | μA |
| t _{ON} | Turn-on time | 10 to 90% SLEEP mode | | | 300 390 | μs |
| t _{OFF} | Turn off time | 90 % to 10 % Pull-down resistor enabled | | | 1 | ms |
| R _{OFF} | Pull-down resistance in OFF mode | Can be disabled via LDO3_PD_DIS | | 100 | | Ω |
| Bypass Mode | | | | | | |
| R _{ON} | Bypass on-resistance | V _{DD} > 2.2 V | | 0.5 | 0.7 | Ω |
| | | V _{DD} > 1.8 V | | | 1.0 | |

System PMIC for Mobile and Automotive Applications

| Parameter | Description | Conditions | Min | Typ | Max | Unit |
|-----------------|----------------------------------|------------|-----|-----|-----|---------|
| I_{LIM} | Current limit in Bypass mode | | | 380 | | mA |
| I_{Q_BYPASS} | Quiescent current in Bypass mode | | | 50 | 100 | μ A |

Note 1 Max output current is 30 % when the input voltage is 1.5 V.

Note 2 Programmable in 20 mV voltage steps.

Note 3 Accuracy values not applicable if bypass mode has been configured.

Note 4 Measured at point of load.

Note 5 Internal regulator current flowing to ground.

System PMIC for Mobile and Automotive Applications

5.7.2 LDO7

Table 13: LDO7, $T_J = -40\text{ °C to }+125\text{ °C}$

| Parameter | Description | Conditions | Min | Typ | Max | Unit |
|----------------------------------|-----------------------------------|--|---------------|--------|-------|------|
| V _{DD} | Input voltage | V _{DD} = V _{sys} | 2.8 | | 5.5 | V |
| | | If supplied from buck | 1.5 Note 1 | | | |
| V _{LDO} | Output voltage | | 0.9 | Note 2 | 3.6 | V |
| V _{LDO_ACC} | Output accuracy Note 3 | V _{DD} = V _{sys} = 2.8 V to 5.5 V I _{OUT} = 200 mA Including static line/load regulation | -3 | | +3 | % |
| C _{OUT} | Stabilization capacitor | Including voltage and temperature coefficient at configured VLDO7 | -55 % | 2.2 | +35 % | μF |
| R _{COU_T_ESR} | ESR of capacitor | f > 1 MHz Including track impedance | 0 | | 300 | mΩ |
| I _{OUT_MAX} | Maximum output current | V _{DD} = V _{sys} = 2.8 V to 5.5 V | 200 | | | mA |
| I _{SHORT} | Short circuit current | | | 400 | | mA |
| I _{SLEEP} | Maximum forced sleep mode current | V _{DD} ≥ 1.8 V | 30 | | | mA |
| V _{DROPOUT} | Dropout voltage | V _{DD} = V _{sys} > 2.8 V I _{OUT} = 200 mA (V _{DD} = 1.5 V, I _{OUT} = I _{MAX} /3) | | 100 | 150 | mV |
| V _{S_LINE} | Static line regulation | V _{DD} = V _{sys} = 3.0V to 5.5 V I _{OUT} = 200 mA | | 1 | 5 | mV |
| V _{S_LOAD} | Static load regulation | I _{OUT} = 1 mA to 200 mA | | 5 | 10 | mV |
| V _{TR_LINE} | Line transient response | V _{DD} = V _{sys} = 3.0 V to 3.6 V I _{OUT} = 100 mA tr = tf = 10 μs | | 5 | 10 | mV |
| V _{TR_LOAD} | Load transient response | V _{DD} = 3.6 V I _{OUT} = 1 mA to 200 mA tr = tf = 1 μs | | 30 | 50 | mV |
| PSRR Note 4 | PSRR | f = 10 Hz to 10 kHz, RT V _{DD} = 3.6 V, I _{OUT} = I _{MAX} /2 V _{DD} - V _{LDO} ≥ 0.6 V | 50 | 60 | | dB |

System PMIC for Mobile and Automotive Applications

| Parameter | Description | Conditions | Min | Typ | Max | Unit |
|--------------------|-------------------------------------|---|-----|-----------------------|-----|---------------------|
| N | Output noise | $V_{DD} = V_{sys} = 3.6\text{ V}$, $V_{LDO} = 2.8\text{ V}$ $I_{OUT} = 5\text{ mA to } I_{MAX}$ $f = 10\text{ Hz to } 100\text{ kHz}$, RT | | 70 | | μV_{rms} |
| I_{Q_ON} | Quiescent current in ON mode | Note 5 | | 9+0.4% of I_{OUT} | | μA |
| I_{Q_SLEEP} | Quiescent current forced sleep mode | | | 1.5+1.0% of I_{OUT} | | μA |
| I_{Q_OFF} | Quiescent current OFF mode | | | 1 | | μA |
| t_{ON} | Turn-on time | 10 % to 90 % | | | 300 | μs |
| | | SLEEP mode | | | 390 | |
| t_{OFF} | Turn off time | 90 % to 10 % Pull-down resistor enabled | | | 1 | ms |
| R_{OFF} | Pull-down resistance in OFF mode | Can be disabled via LDO7_PD_DIS | | 100 | | Ω |
| Bypass Mode | | | | | | |
| R_{ON} | Bypass on-resistance | $V_{DD} > 2.2\text{ V}$ | | 0.5 | 0.7 | Ω |
| | | $V_{DD} > 1.8\text{ V}$ | | | 1.0 | |
| I_{LIM} | Current limit in Bypass mode | | | 280 | | mA |
| I_{Q_BYPASS} | Quiescent current | | | 50 | 100 | μA |

Note 1 Max output current is 30 % when the input voltage is 1.5 V.

Note 2 Programmable in 50 mV voltage steps.

Note 3 Accuracy values not applicable if bypass mode has been configured.

Note 4 Measured at point of load.

Note 5 Internal regulator current flowing to ground.

System PMIC for Mobile and Automotive Applications

5.7.3 LDO8

Table 14: LDO8, $T_J = -40\text{ °C to }+125\text{ °C}$

| Parameter | Description | Conditions | Min | Typ | Max | Unit |
|----------------------------------|-----------------------------------|--|---------------|--------|-------|------|
| V _{DD} | Input voltage | V _{DD} = V _{SYS} | 2.8 | | 5.5 | V |
| | | If supplied from buck | 1.5 Note 1 | | | |
| V _{LDO} | Output voltage | | 0.9 | Note 2 | 3.6 | V |
| V _{LDO_ACC} | Output accuracy Note 3 | V _{DD} = V _{SYS} = 2.8 V to 5.5 V I _{OUT} = 200 mA Including static line/load regulation | -3 | | +3 | % |
| C _{OUT} | Stabilization capacitor | Including voltage and temperature coefficient at configured VLDO8 | -55 % | 2.2 | +35 % | μF |
| R _{COU_T_ESR} | ESR of capacitor | f > 1 MHz Including track impedance | 0 | | 300 | mΩ |
| I _{OUT_MAX} | Maximum output current | V _{DD} = V _{SYS} = 2.8 V to 5.5 V | 200 | | | mA |
| I _{SHORT} | Short circuit current | | | 400 | | mA |
| I _{SLEEP} | Maximum forced sleep mode current | V _{DD} ≥ 1.8 V | 30 | | | mA |
| V _{DROPOUT} | Dropout voltage | V _{DD} = V _{SYS} > 2.8 V I _{OUT} = 200 mA (V _{DD} = 1.5 V, I _{OUT} = I _{MAX} /3) | | 100 | 150 | mV |
| V _{S_LINE} | Static line regulation | V _{DD} = V _{SYS} = 3.0 V to 5.5 V I _{OUT} = 200 mA | | 1 | 5 | mV |
| V _{S_LOAD} | Static load regulation | I _{OUT} = 1 mA to 200 mA | | 5 | 10 | mV |
| V _{TR_LINE} | Line transient response | V _{DD} = V _{SYS} = 3.0 V to 3.6 V I _{OUT} = 100 mA tr = tf = 10 μs | | 5 | 10 | mV |
| V _{TR_LOAD} | Load transient response | V _{DD} = 3.6 V I _{OUT} = 1 mA to 200 mA tr = tf = 1 μs | | 30 | 50 | mV |
| PSRR Note 4 | PSRR | f = 10 Hz to 10 kHz, RT V _{DD} = 3.6 V, I _{OUT} = I _{MAX} /2 V _{DD} - V _{LDO} ≥ 0.6 V | 50 | 60 | | dB |

System PMIC for Mobile and Automotive Applications

| Parameter | Description | Conditions | Min | Typ | Max | Unit |
|------------------------------------|-------------------------------------|---|-----|-------------------------------|-------|---------------------|
| N | Output noise | $V_{DD} = V_{SYS} = 3.6\text{ V}$, $V_{LDO} = 2.8\text{ V}$ $I_{OUT} = 5\text{ mA to } I_{MAX}$ $f = 10\text{ Hz to } 100\text{ kHz, RT}$ | | 70 | | μV_{rms} |
| I_{Q_ON} | Quiescent current in ON mode | Note 5 | | $9 + 0.4\%$ of I_{OUT} | | μA |
| I_{Q_SLEEP} | Quiescent current forced sleep mode | | | $1.5 + 1.0\%$ of I_{OUT} | | μA |
| I_{Q_OFF} | Quiescent current OFF mode | | | 1 | | μA |
| t_{ON} | Turn-on time | 10 % to 90 % | | | 300 | μs |
| | | SLEEP mode | | | 390 | |
| t_{OFF} | Turn off time | 90 % to 10 % Pull-down resistor enabled | | | 1 | ms |
| R_{OFF} | Pull-down resistance in OFF mode | Can be disabled via LDO8_PD_DIS | | 100 | | Ω |
| Vibration Motor Driver Mode | | | | | | |
| VIB_SET | Output voltage (average) | 6-bit resolution | 0 | | 3 | V |
| I_{MAX} | Maximum output current | | | | 300 | mA |
| I_{SHORT} | Short circuit current | | | 400 | | mA |
| R_{LOAD} | Load resistance | | 8 | 10 | 10000 | Ω |
| R_{LOAD} | Load impedance | | | 200 | | μH |
| R_{ON} | Pull-up resistor | | | 0.5 | | Ω |
| R_{OFF} | Pull-down resistor | | | 5 | | Ω |
| Bypass Mode | | | | | | |
| R_{ON} | Bypass on-resistance | $V_{DD} > 2.2\text{ V}$ | | 0.5 | 0.7 | Ω |
| | | $V_{DD} > 1.8\text{ V}$ | | | 1.0 | |
| I_{LIM} | Current limit in Bypass mode | | | 400 | | mA |
| I_{Q_BYPASS} | Quiescent current in Bypass mode | | | 50 | 100 | μA |

Note 1 Max output current is 30 % when the input voltage is 1.5 V.

Note 2 Programmable in 50 mV voltage steps.

Note 3 Accuracy values not applicable if bypass mode has been configured.

Note 4 Measured at point of load.

Note 5 Internal regulator current flowing to ground.

System PMIC for Mobile and Automotive Applications

5.7.4 LDO9

Table 15: LDO9, $T_J = -40\text{ °C}$ to $+125\text{ °C}$

| Parameter | Description | Conditions | Min | Typ | Max | Unit |
|------------------------|-----------------------------------|--|---------------|--------|-------|------|
| V _{DD} | Input voltage | V _{DD} = V _{SYS} | 2.8 | | 5.5 | V |
| | | If supplied from buck | 1.5 Note 1 | | | |
| V _{LDO} | Output voltage | | 0.95 | Note 2 | 3.6 | V |
| V _{LDO_ACC} | Output accuracy | V _{DD} = V _{SYS} = 2.8 V to 5.5 V I _{OUT} = 200 mA Including static line/load regulation Note 3 | -3 | | +3 | % |
| C _{OUT} | Stabilization capacitor | Including voltage and temperature coefficient at configured VLDO9 | -55 % | 2.2 | +35 % | μF |
| R _{COU_T_ESR} | ESR of capacitor | f > 1 MHz | 0 | | 300 | mΩ |
| I _{OUT_MAX} | Maximum output current | V _{DD} = V _{SYS} = 2.8 V to 5.5 V | 200 | | | mA |
| I _{SHORT} | Short circuit current | | | 400 | | mA |
| I _{SLEEP} | Maximum forced sleep mode current | V _{DD} ≥ 1.8 V | 30 | | | mA |
| V _{DROPOUT} | Dropout voltage | V _{DD} = V _{SYS} > 2.8 V I _{OUT} = 200 mA (V _{DD} = 1.5 V, I _{OUT} = I _{MAX} /3) | | 100 | 150 | mV |
| V _{S_LINE} | Static line regulation | V _{DD} = V _{SYS} = 3.0 V to 5.5 V I _{OUT} = 200 mA | | 1 | 5 | mV |
| V _{S_LOAD} | Static load regulation | I _{OUT} = 1 mA to 200 mA | | 5 | 10 | mV |
| V _{TR_LINE} | Line transient response | V _{DD} = V _{SYS} = 3.0 V to 3.6 V I _{OUT} = 100 mA tr = tf = 10 μs | | 5 | 10 | mV |
| V _{TR_LOAD} | Load transient response | V _{DD} = 3.6 V I _{OUT} = 1 mA to 200 mA tr = tf = 1 μs | | 30 | 50 | mV |
| PSRR Note 4 | PSRR | f = 10 Hz to 10 kHz, RT V _{DD} = 3.6 V, I _{OUT} = I _{MAX} /2 V _{DD} - V _{LDO} ≥ 0.6 V | 60 | 70 | | dB |

System PMIC for Mobile and Automotive Applications

| Parameter | Description | Conditions | Min | Typ | Max | Unit |
|----------------|-------------------------------------|---|-----|------------------------|-----|-------------------|
| N | Output noise | $V_{DD} = V_{sys} = 3.6\text{ V}$, $V_{LDO} = 2.8\text{ V}$ $I_{OUT} = 5\text{ mA to } I_{MAX}$ $f = 10\text{ Hz to } 100\text{ kHz, RT}$ | | 35 | | $\mu\text{V rms}$ |
| I_{Q_ON} | Quiescent current in ON mode | Note 5 | | $9+0.4\%$ of I_{OUT} | | μA |
| I_{Q_SLEEP} | Quiescent current forced sleep mode | | | $2+1.0\%$ of I_{OUT} | | μA |
| I_{Q_OFF} | Quiescent current OFF mode | | | 1 | | μA |
| t_{ON} | Turn-on time | 10 % to 90 % | | | 200 | μs |
| | | SLEEP mode | | | 260 | |
| t_{OFF} | Turn off time | 90 % to 10 % Pull-down resistor enabled | | | 1 | ms |
| R_{OFF} | Pull-down resistance in OFF mode | Can be disabled via LDO9_PD_DIS | | 100 | | Ω |

Note 1 Max output current is 30 % when the input voltage is 1.5 V.

Note 2 Programmable in 50 mV voltage steps.

Note 3 At trimmed output voltage.

Note 4 Measured at point of load.

Note 5 Internal regulator current flowing to ground.

System PMIC for Mobile and Automotive Applications

5.7.5 LDO11

Table 16: LDO11, $T_J = -40\text{ °C to }+125\text{ °C}$

| Parameter | Description | Conditions | Min | Typ | Max | Unit |
|----------------------------------|----------------------------|--|---------------|--------|-------|------|
| V _{DD} | Input voltage | V _{DD} = V _{sys} | 2.8 | | 5.5 | V |
| | | If supplied from buck | 1.5 Note 1 | | | |
| V _{LDO} | Output voltage | | 0.9 | Note 2 | 3.6 | V |
| V _{LDO_ACC} | Output accuracy Note 3 | V _{DD} = V _{sys} = 2.8V to 5.5 V I _{OUT} = 200 mA Including static line/load regulation | -3 | | +3 | % |
| C _{OUT} | Stabilization capacitor | Including voltage and temperature coefficient at configured VLDO11 | -55 % | 2.2 | +35 % | μF |
| R _{COU_T_ESR} | ESR of capacitor | f > 1 MHz Including track impedance | 0 | | 300 | mΩ |
| I _{OUT_MAX} | Maximum output current | V _{DD} = V _{sys} = 2.8 V to 5.5 V | 300 | | | mA |
| I _{SHORT} | Short circuit current | | | 600 | | mA |
| I _{SLEEP} | Maximum sleep mode current | V _{DD} ≥ 1.8 V | 30 | | | mA |
| V _{DROPOUT} | Dropout voltage | V _{DD} = V _{sys} > 2.8 V I _{OUT} = 300 mA (V _{DD} = 1.5 V, I _{OUT} = I _{MAX} /3) | | 100 | 150 | mV |
| V _{S_LINE} | Static line regulation | V _{DD} = V _{sys} = 2.8 V to 5.5 V V _{LDO} = 1.86 V I _{OUT} = 300 mA | | 2 | 15 | mV |
| V _{S_LOAD} | Static load regulation | I _{OUT} = 1 mA to 300 mA | | 5 | 20 | mV |
| V _{TR_LINE} | Line transient response | V _{DD} = V _{sys} = 2.8 V to 5.5 V V _{LDO} = 1.86 V I _{OUT} = 300 mA tr = tf = 10 μs | | 5 | 10 | mV |
| V _{TR_LOAD} | Load transient response | V _{DD} = 3.6 V I _{OUT} = 1 mA to 300 mA tr = tf = 1 μs | | 30 | 50 | mV |
| PSRR Note 4 | PSRR | f = 10 Hz to 10 kHz, RT V _{DD} = 3.6 V, I _{OUT} = I _{MAX} /2 V _{DD} - V _{LDO} ≥ 0.6 V | 60 | 70 | | dB |

System PMIC for Mobile and Automotive Applications

| Parameter | Description | Conditions | Min | Typ | Max | Unit |
|--------------------|-------------------------------------|---|-----|-------------------------------|-----|---------------------|
| N | Output noise | $V_{DD} = V_{SYS} = 3.6\text{ V}$, $V_{LDO} = 2.8\text{ V}$ $I_{OUT} = 5\text{ mA to } I_{MAX}$ $f = 10\text{ Hz to } 100\text{ kHz, RT}$ | | 70 | | μV_{rms} |
| I_{Q_ON} | Quiescent current in ON mode | Note 5 | | 9 + 0.45 % of I_{OUT} | | μA |
| I_{Q_SLEEP} | Quiescent current forced sleep mode | | | 2 + 0.7 % of I_{OUT} | | μA |
| I_{Q_OFF} | Quiescent current OFF mode | | | 1 | | μA |
| t_{ON} | Turn-on time | 10 % to 90 % | | | 200 | μs |
| | | SLEEP mode | | | 260 | |
| t_{OFF} | Turn off time | 90 % to 10 % Pull-down resistor enabled | | | 1 | ms |
| R_{OFF} | Pull-down resistance in OFF mode | Can be disabled via LDO11_PD_DIS | | 100 | | Ω |
| Bypass Mode | | | | | | |
| R_{ON} | Bypass on-resistance | $V_{DD} > 2.2\text{ V}$ | | 0.3 | 0.7 | Ω |
| | | $V_{DD} > 1.8\text{ V}$ | | | 1.0 | |
| I_{LIM} | Current limit in Bypass mode | | | 270 | | mA |
| I_{Q_BYPASS} | Quiescent current in Bypass mode | | | 50 | 100 | μA |

Note 1 Max output current is 30 % when the input voltage is 1.5 V.

Note 2 Programmable in 50 mV voltage steps.

Note 3 Accuracy values not applicable if bypass mode has been configured.

Note 4 Measured at point of load.

Note 5 Internal regulator current flowing to ground.

System PMIC for Mobile and Automotive Applications

5.7.6 LDOCORE

Table 17: LDOCORE, $T_J = -40\text{ }^\circ\text{C}$ to $+125\text{ }^\circ\text{C}$

| Parameter | Description | Conditions | Min | Typ | Max | Unit |
|----------------------------------|-------------------------|---|-------|-----|-------|---------------|
| V _{DDCORE} | Output voltage | Note 1 | 2.45 | 2.5 | 2.55 | V |
| | | RESET mode | | 2.2 | | V |
| C _{OUT} | Stabilization capacitor | Including voltage and temperature coefficient | -55 % | 2.2 | +35 % | μF |
| R _{COU_T_ESR} | Output capacitor ESR | f > 1 MHz Including wiring parasitics | 0 | | 300 | m Ω |
| V _{DROPOUT} | Dropout voltage | Note 2 | | 50 | 100 | mV |

Note 1 Setting VDD_FAULT_LOWER \geq 2.65 V avoids LDOCORE dropout, see Section 5.11.

Note 2 The LDOCORE supply, VSYS or CHG_WAKE, must be maintained above V_{DDCORE} + V_{DROPOUT}.

| Note |
|---|
| LDOCORE is only used to supply internal circuits. |

System PMIC for Mobile and Automotive Applications

5.8 DC/DC Buck Converters

5.8.1 BUCKCORE1 and BUCKCORE2

Table 18: BUCKCORE1 and BUCKCORE2, $T_J = -40\text{ °C}$ to $+125\text{ °C}$

| Parameter | Description | Conditions | Min | Typ | Max | Unit |
|-----------------|-------------------------|---|-------|--------|---------------------------------|------------------|
| V_{DD} | Input voltage | $V_{DD} = V_{SYS}$ | 2.8 | | 5.5 | V |
| C_{OUT} | Output capacitor | Including voltage and temperature coefficient Half-current mode | -50 % | 2 x 22 | +30 % Note 1 | μF |
| | | Full-current mode | | 2 x 47 | | |
| R_{COUT_ESR} | Output capacitor ESR | Including wiring parasitics $f > 100\text{ kHz}$ Half-current mode $C_{OUT} = 2 * 22\text{ }\mu\text{F}$ | | 15 | 50 | $\text{m}\Omega$ |
| | | Full-current mode $C_{OUT} = 2 * 47\text{ }\mu\text{F}$ | | 7.5 | 25 | |
| L_{BUCK} | Inductor value | Including current and temperature dependence | 0.7 | 1.0 | 1.3 | μH |
| L_{ESR} | Inductor resistance | | | 55 | 100 | $\text{m}\Omega$ |
| PWM Mode | | | | | | |
| V_{BUCK} | Output voltage | Programmable in 10 mV steps Note 2 | 0.3 | | 1.57 | V |
| V_{BUCK_ACC} | Output voltage accuracy | Excluding static line/load regulation and voltage ripple $T_A = 25\text{ °C}$ $V_{DD} = 4.2\text{ V}$ $V_{BUCK} = 1.03\text{ V}$ | -1 | | +1 | % |
| | | Excluding static line/load regulation and voltage ripple $T_A = -40\text{ °C}$ to $+85\text{ °C}$ $V_{DD} = 4.2\text{ V}$ $V_{BUCK} = 1.03\text{ V}$ | -1.5 | | +1.5 | |
| | | Including static line/load regulation and voltage ripple $I_{OUT} = I_{MAX}$ $V_{BUCK} = 1.03\text{ V}$ $L_{BUCK}, L_{ESR} = \text{Typ}$ | -2 | | +2 | |

System PMIC for Mobile and Automotive Applications

| Parameter | Description | Conditions | Min | Typ | Max | Unit |
|---------------------|-------------------------------------|--|-------|------|-------|---------------|
| | | Including static line/load regulation and voltage ripple $I_{OUT} = I_{MAX}$ Note 3 | -3 | | +3 | |
| V_{TR_LD} | Load regulation transient | $V_{DD} = 3.6\text{ V}$ $V_{BUCK} = 1.2\text{ V}$ $I_{OUT} = 200\text{ mA} / 0.8 * I_{MAX}$ $dl/dt = 3\text{ A}/\mu\text{s}$ $L_{BUCK} = 1.0\text{ }\mu\text{H}$ Note 4 | -4 | | +4 | % |
| V_{TR_LINE} | Line regulation transient | $V_{DD} = 3.0\text{ V to } 3.6\text{ V}$ $I_{OUT} = 500\text{ mA}$ $t_r = t_f = 10\text{ }\mu\text{s}$ | | 0.2 | 3 | mV |
| | Parasitic track resistance | From output capacitor to sense connection at point-of-load | | 10 | | m Ω |
| | Parasitic track inductance | From output capacitor to sense connection at point-of-load | | 5 | | nH |
| Z_{FB} | Feedback Comparator input impedance | | 500 | | | k Ω |
| I_{MAX} | Output current | Half-current mode | 1250 | | | mA |
| | | Full-current mode | 2500 | | | |
| I_{LIM} Note 5 | Current limit (programmable) | BCORE1_ILIM=0000 | -20 % | 500 | +20 % | mA |
| | | BCORE1_ILIM=1111 | -20 % | 2000 | +20 % | |
| I_{Q_OFF} | Quiescent current in OFF mode | | | | 1 | μA |
| I_{Q_ON} | Quiescent current in PWM mode | Half-current mode $I_{OUT} = 0\text{ mA}$ | | 9.0 | | mA |
| | | Full-current mode | | 11.0 | | |
| f | Switching frequency Note 6 | OSC_FRQ = 0000 | 2.85 | 3 | 3.15 | MHz |
| D | Switching duty cycle | | 10.5 | | 84 | % |
| t_{ON} | Turn on time | $V_{BUCK} = 1.15\text{ V}$ BUCK_SLOWSTART = disabled SLEW_RATE = 10 mV/1 μs BUCK<x>_ILIM = 1500 mA | | 0.37 | 1.2 | ms |

System PMIC for Mobile and Automotive Applications

| Parameter | Description | Conditions | Min | Typ | Max | Unit |
|-----------------------|--|--|-----|-----|------|------|
| R _{PD} | Output pull-down resistor | V _{BUCK} = 0.5 V Can be disabled via BCORE1_PD_DIS | | 80 | 200 | Ω |
| R _{PMOS} | PMOS ON resistance | Half-current mode Including pin and routing V _{sys} = 3.6 V | | 160 | | mΩ |
| | | Full-current mode Including pin and routing V _{sys} = 3.6 V | | 80 | | |
| R _{NMOS} | NMOS ON resistance | Half-current mode Including pin and routing V _{sys} = 3.6 V | | 60 | | mΩ |
| | | Full-current mode Including pin and routing V _{sys} = 3.6 V | | 30 | | |
| η | Efficiency Note 7 | V _{DD} = 3.6 V V _{BUCK} = 1.2 V I _{OUT} = 0.1 to 0.7 * I _{MAX} | | 84 | | % |
| PFM Mode | | | | | | |
| V _{BUCK} | Output voltage | Programmable in 10 mV steps | 0.3 | | 1.57 | V |
| I _{AUTO_THR} | Typical automatic mode switching current | | | 260 | | mA |
| I _{OUT_PFM} | Output current | | | 300 | | mA |
| I _{LIM_PFM} | Current limit | | | 600 | | mA |
| I _{Q_PFM} | Quiescent current | I _{OUT} = 0 Forced PFM mode | | 27 | 32 | μA |
| | | AUTO mode | | 35 | 42 | |
| f | Frequency of operation | | 0 | | 3 | MHz |
| η | Efficiency Note 7 | V _{DD} = 3.6 V V _{BUCK} = 1.2 V I _{OUT} = 10 mA | | 86 | | % |

Note 1 The purpose of the specified maximum C_{OUT} value is to ensure that the specified turn-on time, t_{ON}, can be met. Additional output rail capacitors can be added to reduce voltage ripple or to improve transient load regulation. However, this will compromise t_{ON} performance, create larger in-rush currents and will affect DVC slew rates.

Note 2 If BUCK<x>_MODE = 10 (synchronous) then the buck operates in PFM mode when V_{BUCK} < 0.7 V. For complete control of the buck mode (PWM versus PFM) use BUCK<x>_MODE = 00.

Note 3 Minimum tolerance 35 mV.

Note 4 Measured at C_{OUT}, depends on parasitics of PCB and external components when remote sensing.

System PMIC for Mobile and Automotive Applications

Note 5 Current limit values are doubled in full-current mode.

Note 6 Generated from internal 6 MHz oscillator and can be adjusted by $\pm 10\%$ via control OSC_FRQ.

Note 7 Depends on external components and PCB routing.

System PMIC for Mobile and Automotive Applications

5.8.2 BUCKPRO

Table 19: BUCKPRO, $T_J = -40\text{ °C to }+125\text{ °C}$

| Parameter | Description | Conditions | Min | Typ | Max | Unit |
|-----------------|---------------------------|--|-------|--------|------------------------|------------------|
| V_{DD} | Input voltage | $V_{DD} = V_{SYS}$ | 2.8 | | 5.5 | V |
| C_{OUT} | Output capacitor | Including voltage and temperature coefficient | | | Note 1 | μF |
| | | Half-current mode | -50 % | 2 * 22 | +30 % | |
| | | Full-current mode | | 2 * 47 | | |
| R_{COUT_ESR} | Output capacitor ESR | Including wiring parasitics $f > 100\text{ kHz}$ | | | | $\text{m}\Omega$ |
| | | Half-current mode $C_{OUT} = 2 * 22\ \mu\text{F}$ | | 15 | 50 | |
| | | Full-current mode $C_{OUT} = 2 * 47\ \mu\text{F}$ | | 7.5 | 25 | |
| L_{BUCK} | Inductor value | Including current and temperature dependence | 0.7 | 1.0 | 1.3 | μH |
| L_{ESR} | Inductor resistance | | | 55 | 100 | $\text{m}\Omega$ |
| PWM Mode | | | | | | |
| V_{BUCK} | Output voltage | Programmable in 10 mV steps Note 2 | 0.53 | | 1.8 | V |
| R_{COUT_ESR} | Output voltage accuracy | Including static line/load regulation and voltage ripple $I_{OUT} = I_{MAX}$ Note 3 | -3 | | +3 | % |
| | | Excluding static line/load regulation and voltage ripple $T_A = 25\text{ °C}$ $V_{BUCK} > 1\text{ V}$ $V_{DD} = 5\text{ V}$ | -1 | | +1 | |
| V_{TR_LD} | Transient load regulation | $V_{DD} = 3.6\text{ V}$ $V_{BUCK} = 1.2\text{ V}$ $I_{OUT} = 200\text{ mA} / 0.8 * I_{MAX}$ $dI/dt = 3\text{ A}/\mu\text{s}$ $L_{BUCK} = 1.0\ \mu\text{H}$ Note 4 | | 20 | 50 | mV |

System PMIC for Mobile and Automotive Applications

| Parameter | Description | Conditions | Min | Typ | Max | Unit |
|-----------------|---|--|-------|------|-------|---------------|
| V_{TR_LINE} | Transient line regulation | $V_{DD} = 3.0\text{ V to }3.6\text{ V}$ $I_{OUT} = 500\text{ mA}$ $t_r = t_f = 10\text{ }\mu\text{s}$ | | 0.2 | 3 | mV |
| I_{MAX} | Output current | Half-current mode | 1250 | | | mA |
| | | Full-current mode | 2500 | | | |
| I_{LIM} | Current limit (programmable) | BPRO_ILIM=0000 | -20 % | 500 | +20 % | mA |
| | | BPRO_ILIM=1111 | -20 % | 2000 | +20 % | |
| I_{Q_OFF} | Quiescent current in OFF mode | | | | 1 | μA |
| I_{Q_ON} | Quiescent current in PWM mode | Half-current mode | | 9.0 | | mA |
| | | Full-current mode | | 11.0 | | |
| f | Switching frequency Note 5 | OSC_FRQ = 0000 | 2.85 | 3 | 3.15 | MHz |
| D | Switching duty cycle | | 10.6 | | 84 | % |
| R_{PD} | Output pull-down resistor | @ $V_{OUT} = 0.5\text{ V}$ Can be disabled via BPRO_PD_DIS | | 80 | 200 | Ω |
| R_{PMOS} | PMOS ON resistance | Half-current mode Including pin and routing $V_{SYS} = 3.6\text{ V}$ | | 160 | | m Ω |
| | | Full-current mode Including pin and routing $V_{SYS} = 3.6\text{ V}$ | | 80 | | |
| R_{NMOS} | NMOS ON resistance | Half-current mode Including pin and routing $V_{SYS} = 3.6\text{ V}$ | | 60 | | m Ω |
| | | Full-current mode Including pin and routing $V_{SYS} = 3.6\text{ V}$ | | 30 | | |
| η | Efficiency Note 6 | $V_{DD} = 3.6\text{ V}$ $V_{BUCK} = 1.2\text{ V}$ $I_{OUT} = 0.1\text{ mA to }0.7\text{ *}$ I_{MAX} | | 84 | | % |
| PFM Mode | | | | | | |

System PMIC for Mobile and Automotive Applications

| Parameter | Description | Conditions | Min | Typ | Max | Unit |
|-----------------|--|---|-------|--------|-------|------------|
| V_{BUCK} | Output voltage | Programmable in 10 mV steps | 0.53 | | 1.8 | V |
| I_{AUTO_THR} | Typical automatic mode switching current | | | 260 | | mA |
| I_{OUT_PFM} | Output current | | | 300 | | mA |
| I_{LIM} | Current limit | | | 600 | | mA |
| I_{Q_PFM} | Quiescent current | $I_{OUT} = 0$ mA Forced PFM mode | | 22 | 25 | μ A |
| | | AUTO mode | | 30 | 35 | |
| f | Frequency of operation | | 0 | | 3 | MHz |
| η | Efficiency Note 6 | $V_{DD} = 3.6$ V $V_{BUCK} = 1.2$ V $I_{OUT} = 10$ mA | | 86 | | % |
| VTT Mode | | | | | | |
| V_{DD} | Input voltage | $V_{DD} = V_{SYS}$ | 2.8 | | 5.5 | V |
| C_{OUT} | Output capacitor | Including voltage and temperature coefficient | -50 % | 2 * 47 | +30 % | μ F |
| R_{COUT_ESR} | Output capacitor ESR | ESR of C_{OUT} @ f > 100 kHz + track impedance | | 7.5 | 25 | m Ω |
| L_{BUCK} | Inductor value | Including current and temperature dependence | | 0.25 | | μ H |
| L_{ESR} | Inductor resistance | | | 55 | 100 | m Ω |
| V_{BUCK} | Output voltage | $V_{BUCK} = V_{DDQ}/2$ | 0.675 | | 1.3 | V |
| V_{BUCK_ACC} | Output voltage accuracy | Relative to VTTR Including static line and load regulation | - 3 | | 4 | % |
| V_{TR_LD} | Transient load regulation | Half-current mode $V_{DD} = 3.6$ V $V_{BUCK} = 0.7$ V $I_{OUT} = 10$ mA to 1 A $I_{OUT} = -750$ mA to -10 mA $L_{BUCK} = 0.24$ μ H $di/dt = 3$ A/ μ s | | 20 | 40 | mV |
| | | Full-current mode $V_{DD} = 3.6$ V $V_{BUCK} = 0.75$ V $I_{OUT} = 10$ mA to 1.4 A $I_{OUT} = -10$ mA to -1.4 A | | 20 | 40 | |

System PMIC for Mobile and Automotive Applications

| Parameter | Description | Conditions | Min | Typ | Max | Unit |
|--------------------|------------------------|---|-------|-------------|-------|---------------|
| | | $L_{BUCK} = 0.24 \mu\text{H}$ $di/dt = 3 \text{ A}/\mu\text{s}$ | | | | |
| | | Full-current mode $V_{DD} = 3.6 \text{ V}$ $V_{BUCK} = 0.7 \text{ V}$ $I_{OUT} = 10 \text{ mA to } 1.1 \text{ A}$ $I_{OUT} = -10 \text{ mA to } -1.1 \text{ A}$ $L_{BUCK} = 0.24 \mu\text{H}$ $di/dt = 3 \text{ A}/\mu\text{s}$ | | 20 | 40 | |
| | | Full-current mode $V_{DD} = 3.6 \text{ V}$ $V_{BUCK} = 0.675 \text{ V}$ $I_{OUT} = 10 \text{ mA to } 900 \text{ mA}$ $I_{OUT} = -10 \text{ mA to } -900 \text{ mA}$ $L_{BUCK} = 0.24 \mu\text{H}$ $di/dt = 3 \text{ A}/\mu\text{s}$ | | 20 | 40 | |
| I_{MAX} | Maximum output current | Half-current mode $V_{BUCK} = 0.7 \text{ V}$ | -550 | | 1250 | mA |
| | | Full-current mode $V_{BUCK} = 0.75$ | -1400 | | 2500 | mA |
| | | Full-current mode $V_{BUCK} = 0.7 \text{ V}$ | -1100 | | 2500 | |
| | | Full-current mode $V_{BUCK} = 0.675 \text{ V}$ | -900 | | 2500 | |
| t_{ON} | Turn-on time | $V_{BUCK} = 0.75 \text{ V}$ BUCK_SLOWSTART = disabled SLEW_RATE = $10 \text{ mV}/1 \mu\text{s}$ BUCK4_ILIM = 1500 mA | | 0.33 | 1.2 | ms |
| VTTR Buffer | | | | | | |
| V_{DDQ} | Feedback voltage | $V_{DD} = V_{SYS}$ | 1.35 | | 2.6 | V |
| V_{VTTR} | Output voltage | $I_{OUT} = 0 \text{ mA to } I_{VTTR}$ | 0.675 | $V_{DDQ}/2$ | 1.3 | V |
| V_{VTTR_ACC} | Voltage accuracy | V_{VTTR_ACC} related to V_{DDQ} input voltage | -1 | $V_{DDQ}/2$ | +1 | % |
| C_{OUT} | Output capacitor | Including voltage and temperature coefficient | -50 % | 0.1 | +30 % | μF |

System PMIC for Mobile and Automotive Applications

| Parameter | Description | Conditions | Min | Typ | Max | Unit |
|------------------|---------------------|------------|-----|-----|-----|------|
| I _{OUT} | Sink/source current | | -10 | | 10 | mA |

Note 1 The purpose of the specified maximum C_{OUT} value is to ensure that the specified turn-on time, t_{ON}, can be met. Additional output rail capacitors can be added to reduce voltage ripple or to improve transient load regulation. However, this will compromise t_{ON} performance, create larger in-rush currents and will affect DVC slew rates.

Note 2 If BUCK<x>_MODE = 10 (synchronous) then the buck operates in PFM mode when V_{BUCK} < 0.7 V. For complete control of the buck mode (PWM versus PFM) use BUCK<x>_MODE = 00.

Note 3 Minimum tolerance 35 mV.

Note 4 Measured at C_{OUT}, depends on parasitics of PCB and external components when remote sensing.

Note 5 Generated from internal 6 MHz oscillator and can be adjusted by ± 10 % via control OSC_FRQ.

Note 6 Depends on external components and PCB routing.

System PMIC for Mobile and Automotive Applications

5.8.3 BUCKMEM

Table 20: BUCKMEM, $T_J = -40\text{ °C}$ to $+125\text{ °C}$

| Parameter | Description | Conditions | Min | Typ | Max | Unit |
|---------------------|------------------------------|---|-------|--------|-----------------|------------------|
| V_{DD} | Input voltage | $V_{DD} = V_{SYS}$ | 2.8 | | 5.5 | V |
| C_{OUT} | Output capacitor | Including voltage and temperature coefficient | -50 % | 2 * 22 | Note 1 +30 % | μF |
| | | Merged mode | | 2 * 47 | | |
| R_{COUT_ESR} | Output capacitor ESR | Including wiring parasitics $f > 100\text{ kHz}$ | | | | |
| | | $C_{OUT} = 2 * 22\ \mu\text{F}$ | | 15 | 50 | $\text{m}\Omega$ |
| | | $C_{OUT} = 2 * 47\ \mu\text{F}$ | | 7.5 | 25 | |
| L_{BUCK} | Inductor value | Including current and temperature dependence | 0.7 | 1.0 | 1.3 | μH |
| L_{ESR} | Inductor resistance | | | 55 | 100 | $\text{m}\Omega$ |
| V_{BUCK} | Output voltage | Programmable in 20 mV steps | 0.8 | | 3.34 Note 7 | V |
| V_{BUCK_ACC} | Output voltage accuracy | Including static line/load regulation and voltage ripple $I_{OUT} = I_{MAX}$ Note 2 | -3 | | +3 | % |
| | | Excluding static line/load regulation and voltage ripple $T_A = 25\text{ °C}$ $V_{DD} = 5\text{ V}$ $V_{BUCK} > 1\text{ V}$ | -2 | | +2 | |
| V_{TR_LD} | Transient load regulation | $V_{DD} = 3.6\text{ V}$ $V_{BUCK} = 1.2\text{ V}$ $I_{OUT} = 200\text{ mA} / 0.8 * I_{MAX}$ $di/dt = 3\text{ A}/\mu\text{s}$ Note 3 | -4 | | +4 | % |
| V_{TR_LINE} | Transient line regulation | $V_{DD} = 3.0\text{ V}$ to 3.6 V $I_{OUT} = 500\text{ mA}$ $tr = tf = 10\ \mu\text{s}$ | | 0.2 | 3 | mV |
| I_{MAX} | Output current | | 1500 | | | mA |
| I_{LIM} Note 4 | Current limit (programmable) | $BMEM_ILIM = 0000$ | -20 % | 1500 | +20 % | mA |

System PMIC for Mobile and Automotive Applications

| Parameter | Description | Conditions | Min | Typ | Max | Unit |
|--------------------|---|--|-------|----------|--------------------------------|------|
| | | BMEM_ILIM = 1111 | -20 % | 3000 | +20 % | mA |
| I _{Q_OFF} | Quiescent current in OFF mode | | | | 1 | μA |
| I _{Q_ON} | Quiescent current in PWM mode | I _{OUT} = 0 mA | | 9 | | mA |
| f | Switching frequency Note 5 | OSC_FRQ = 0000 | 2.85 | 3 | 3.15 | MHz |
| D | Switching duty cycle | | 14.5 | | 100 | % |
| | Output pull-down resistor | V _{BUCK} = 0.5 V Disabled via BMEM_PD_DIS | | 80 | 200 | Ω |
| R _{PMOS} | PMOS ON resistance | Including pin and routing V _{SYS} = 3.6 V | | 160 | | mΩ |
| R _{NMOS} | NMOS ON resistance | Including pin and routing V _{SYS} = 3.6 V | | 60 | | mΩ |
| η | Efficiency Note 6 | V _{DD} = 3.6 V V _{BUCK} = 1.2 V I _{OUT} = 0.1 mA to 0.7 * I _{MAX} | | 83 | | % |
| PFM Mode | | | | | | |
| V _{BUCK} | Output voltage | Programmable in 20 mV steps | 0.8 | | 3.34 Note 7 | V |
| | Typical automatic mode switching current | | | 260 | | mA |
| I _{MAX} | Output current | | | 300 | | mA |
| I _{LIM} | Current limit | | | 600 | | mA |
| I _{Q_PFM} | Quiescent current | I _{OUT} = 0 mA Forced PFM mode AUTO mode | | 22 30 | 25 35 | μA |
| f | Frequency of operation | | 0 | | 3 | MHz |
| η | Efficiency Note 6 | V _{DD} = 3.6 V V _{BUCK} = 1.2 V I _{OUT} = 10 mA | | 86 | | % |

Note 1 The purpose of the specified maximum C_{OUT} value is to ensure that the specified turn-on time, t_{ON}, can be met. Additional output rail capacitors can be added to reduce voltage ripple or to improve transient load regulation. However, this will compromise t_{ON} performance, create larger in-rush currents and will affect DVC slew rates.

Note 2 Minimum tolerance 35 mV.

Note 3 Measured at C_{OUT}, depends on parasitics of PCB and external components when remote sensing.

System PMIC for Mobile and Automotive Applications

- Note 4** The current limits are automatically doubled when BUCKMEM is merged with BUCKIO.
- Note 5** Generated from internal 6 MHz oscillator and can be adjusted by $\pm 10\%$ via control OSC_FRQ.
- Note 6** Depends on external components and PCB routing.
- Note 7** Maximum $V_{DD} - 0.7\text{ V}$.

System PMIC for Mobile and Automotive Applications

5.8.4 BUCKIO

Table 21: BUCKIO, $T_J = -40\text{ °C}$ to $+125\text{ °C}$

| Parameter | Description | Conditions | Min | Typ | Max | Unit |
|----------------------------------|-------------------------------|---|-------|--------|----------------|------|
| V _{DD} | Input voltage | V _{DD} = V _{SYS} | 2.8 | | 5.5 | V |
| C _{OUT} | Output capacitor | Including voltage and temperature coefficient | -50% | 2x22 | Note 1 +30% | μF |
| R _{CO_{UT}_ESR} | Output capacitor ESR | f > 100 kHz All caps + track impedance | | 15 | 50 | mΩ |
| L _{BUCK} | Inductor value | Including current and temperature dependence | 0.7 | 1.0 | 1.3 | μH |
| L _{ESR} | Inductor resistance | | | 55 | 100 | mΩ |
| PWM Mode | | | | | | |
| V _{BUCK} | Output voltage | Programmable in 20 mV steps Note 2 | 0.8 | | 3.34 Note 3 | V |
| V _{BUCK_ACC} | Output voltage accuracy | Including static line/load regulation and voltage ripple @ I _{OUT} = I _{MAX} | -3 | Note 4 | +3 | % |
| | | T _A = 25 °C I _{OUT} = 0 V _{OUT} > 1 V V _{DD} = 5 V | -2 | | +2 | |
| V _{TR_LD} | Load regulation transient | I _{OUT} = 200 mA/0.8 * I _{MAX} dI/dt = 3 A/μs | -4 | Note 5 | +4 | % |
| V _{TR_LINE} | Line regulation transient | V _{DD} = 3.0 V to 3.6 V I _{OUT} = 500 mA tr = tf = 10 μs | | 0.2 | 3 | mV |
| I _{MAX} | Output current | | 1500 | | | mA |
| I _{LIM} | Current limit (programmable) | BIO_ILIM=0000 | -20 % | 1500 | 20 % | mA |
| | | BIO_ILIM=1111 | -20 % | 3000 | 20 % | mA |
| I _{Q_OFF} | Quiescent current in OFF mode | | | | 1 | μA |
| I _{Q_ON} | Quiescent current in PWM mode | | | 9 | | mA |
| f | Switching frequency | | 2.85 | 3 | 3.15 | MHz |
| D | Switching duty cycle | | 14.5 | | 100 | % |
| | Output pull-down resistor | V _{OUT} = 0.5 V Can be disabled via BIO_PD_DIS | | 80 | 200 | Ω |

System PMIC for Mobile and Automotive Applications

| Parameter | Description | Conditions | Min | Typ | Max | Unit |
|--------------------|--|--|-----|-----|-----|------|
| R _{PMOS} | PMOS ON resistance | Including pin and routing V _{sys} = 3.6 V | | 160 | | mΩ |
| R _{NMOS} | NMOS ON resistance | Including pin and routing V _{sys} = 3.6 V | | 60 | | mΩ |
| η | Efficiency Note 6 | V _{DD} = 3.6 V V _{BUCK} = 1.8 V I _{OUT} = 0.1 to 0.7 * I _{MAX} | | 87 | | % |
| | PFM Mode | | | | | |
| | Typical automatic mode switching current | | | 260 | | mA |
| I _{MAX} | Output current | | | 300 | | mA |
| I _{LIM} | Current limit | | | 600 | | mA |
| I _{Q_PFM} | Quiescent current | I _{OUT} = 0 mA | | 22 | 25 | μA |
| | | Forced PFM mode | | | | |
| | | AUTO mode | | | | |
| f | Frequency of operation | | 0 | | 3 | MHz |
| η | Efficiency Note 6 | V _{DD} = 3.6 V V _{BUCK} = 1.8 V I _{OUT} = 10 mA | | 90 | | % |

Note 1 The purpose of the specified maximum C_{OUT} value is to ensure that the specified turn-on time, t_{ON}, can be met. Additional output rail capacitors can be added to reduce voltage ripple or to improve transient load regulation. However, this will compromise t_{ON} performance, create larger in-rush currents and will affect DVC slew rates.

Note 2 If BUCK<x>_MODE = 10 (synchronous) then the buck operates in PFM mode when V_{BUCK} < 0.7 V. For complete control of the buck mode (PWM versus PFM) use BUCK<x>_MODE = 00.

Note 3 Maximum V_{DD} - 0.7 V.

Note 4 Minimum tolerance 35 mV.

Note 5 Measured at C_{OUT}, depends on parasitics of PCB and external components when remote sensing.

Note 6 Depends on external components and PCB routing.

System PMIC for Mobile and Automotive Applications

5.8.5 BUCKPERI

Table 22: BUCKPERI, $T_J = -40\text{ }^\circ\text{C}$ to $+125\text{ }^\circ\text{C}$

| Parameter | Description | Conditions | Min | Typ | Max | Unit |
|----------------------------------|-------------------------------|---|-------|--------|-----------------|------|
| V _{DD} | Input voltage | V _{DD} = V _{sys} | 2.8 | | 5.5 | V |
| C _{OUT} | Output capacitor | Including voltage and temperature coefficient | -50 % | 2 x 22 | Note 1 +30 % | μF |
| R _{COU_T_ESR} | Output capacitor ESR | f > 100 kHz All caps + track impedance | | 15 | 50 | mΩ |
| L _{BUCK} | Inductor value | Including current and temperature dependence | 0.7 | 1.0 | 1.3 | μH |
| L _{ESR} | Inductor resistance | | | 55 | 100 | mΩ |
| V _{BUCK} | Output voltage | Programmable in 20 mV steps Note 2 | 0.8 | | 3.34 Note 3 | V |
| V _{BUCK_ACC} | Output voltage accuracy | Including static line/load regulation and voltage ripple I _{OUT} = I _{MAX} | -3 | Note 4 | +3 | % |
| | | T _A = 25 °C I _{OUT} = 0 V _{OUT} > 1 V V _{DD} = 5 V | -2 | | +2 | |
| V _{TR_LD} | Load regulation transient | I _{OUT} = 200 mA/0.8 * I _{MAX} di/dt = 3 A/μs | -4 | Note 5 | +4 | % |
| V _{TR_LINE} | Line regulation transient | V _{DD} = 3.0 V to 3.6 V I _{OUT} = 500 mA tr = tf = 10 μs | | 0.2 | 3 | mV |
| I _{MAX} | Output current | | 1500 | | | mA |
| I _{LIM} | Current limit (programmable) | BPERI_ILIM = 0000 | -20% | 1500 | +20% | mA |
| | | BPERI_ILIM = 1111 | -20% | 3000 | +20% | mA |
| I _{Q_OFF} | Quiescent current in OFF mode | | | 1 | μA | |
| I _{Q_ON} | Quiescent current in PWM mode | | | 9 | | mA |
| f | Switching frequency | | 2.85 | 3 | 3.15 | MHz |
| D | Switching duty cycle | | 14.5 | | 100 | % |
| | Output pull-down resistor | V _{OUT} = 0.5 V Can be disabled via BPERI_PD_DIS | | 80 | 200 | Ω |
| R _{PMOS} | PMOS ON resistance | Including pin and routing V _{sys} = 3.6 V | | 160 | | mΩ |

System PMIC for Mobile and Automotive Applications

| Parameter | Description | Conditions | Min | Typ | Max | Unit |
|--------------------|--|---|-----|-----|-----|------|
| R _{NMOS} | NMOS ON resistance | Including pin and routing V _{sys} = 3.6 V | | 60 | | mΩ |
| η | Efficiency Note 6 | V _{DD} = 3.6 V V _{BUCK} = 2.86 V I _{OUT} = 0.1 to 0.7 * I _{MAX} | | 91 | | % |
| | PFM Mode | | | | | |
| | Typical automatic mode switching current | | | 260 | | mA |
| I _{MAX} | Output current | | | 300 | | mA |
| I _{LIM} | Current limit | | | 600 | | mA |
| I _{Q_PFM} | Quiescent current | I _{OUT} = 0 mA | | | | |
| | | Forced PFM mode | | 22 | 25 | μA |
| | | AUTO mode | | 30 | 35 | |
| f | Frequency of operation | | 0 | | 3 | MHz |
| η | Efficiency Note 6 | V _{DD} = 3.6 V V _{BUCK} = 2.86 V I _{OUT} = 10 mA | | 93 | | % |

Note 1 The purpose of the specified maximum C_{OUT} value is to ensure that the specified turn-on time, t_{ON}, can be met. Additional output rail capacitors can be added to reduce voltage ripple or to improve transient load regulation. However, this will compromise t_{ON} performance, create larger in-rush currents and will affect DVC slew rates.

Note 2 If BUCK<x>_MODE = 10 (synchronous) then the buck operates in PFM mode when V_{BUCK} < 0.7 V. For complete control of the buck mode (PWM versus PFM) use BUCK<x>_MODE = 00.

Note 3 Maximum V_{DD} - 0.7 V.

Note 4 Minimum tolerance 35 mV.

Note 5 Measured at C_{OUT}, depends on parasitics of PCB and external components when remote sensing.

Note 6 Depends on external components and PCB routing.

System PMIC for Mobile and Automotive Applications

5.8.6 Typical Characteristics

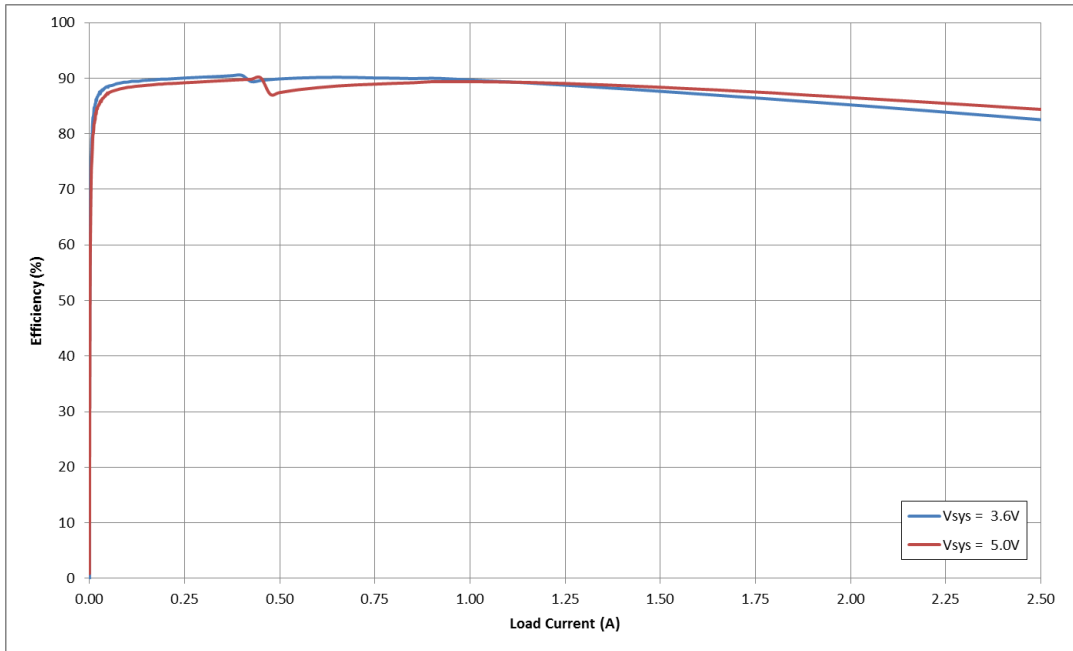

Figure 6: BUCKCORE1 Efficiency in AUTO Mode, V_{OUT} = 1.2 V

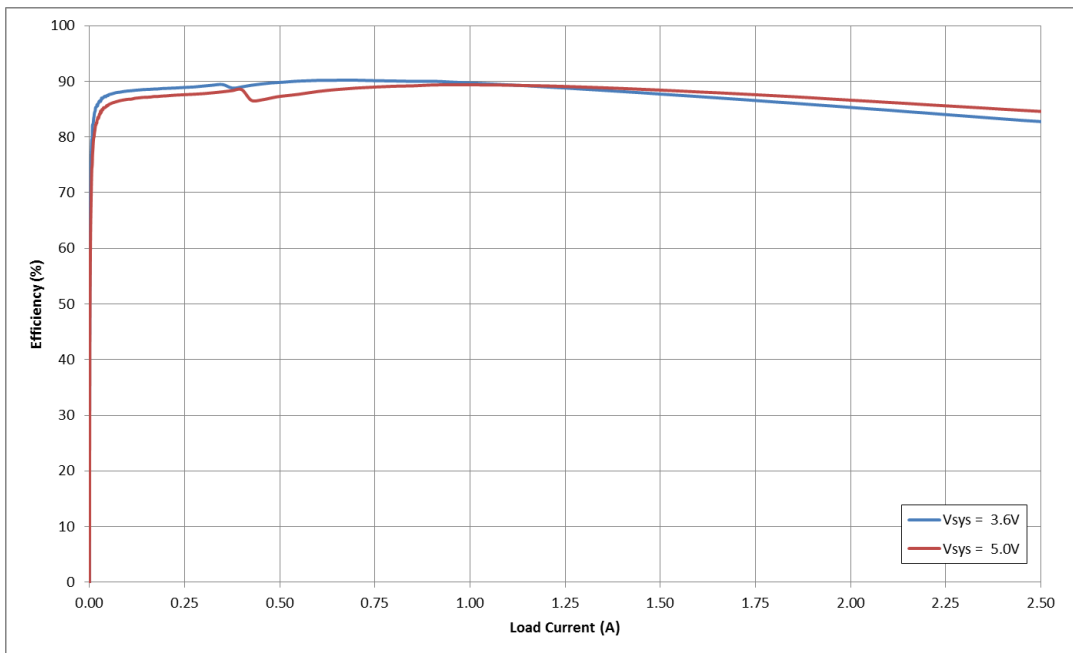

Figure 7: BUCKCORE2 Efficiency in AUTO Mode, V_{OUT} = 1.2 V

System PMIC for Mobile and Automotive Applications

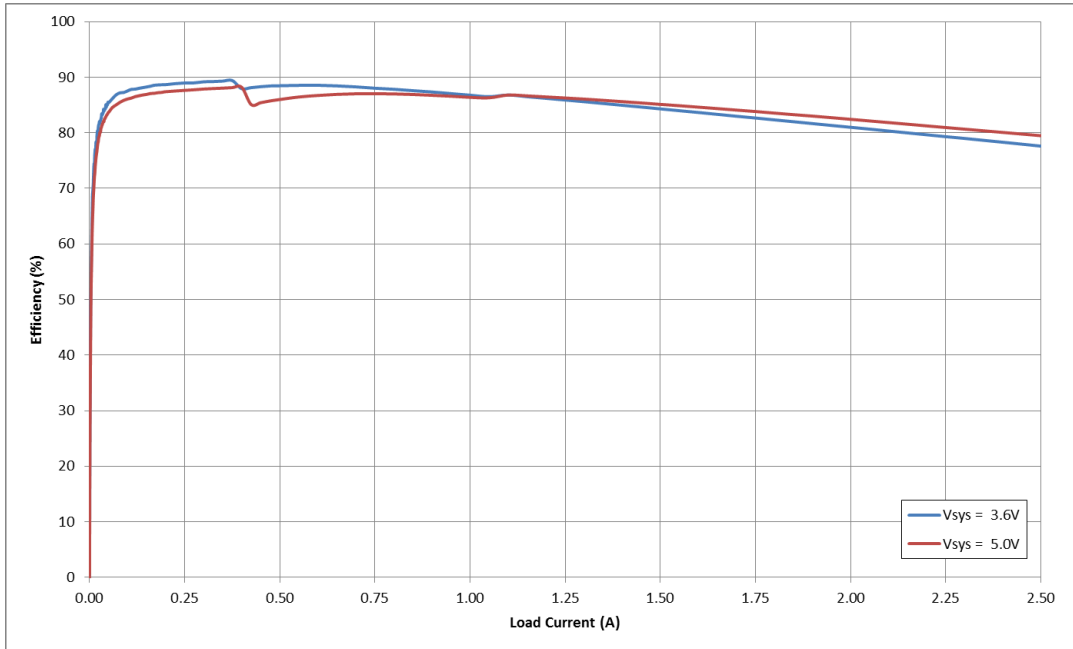

Figure 8: BUCKPRO Efficiency in AUTO Mode, V_{OUT} = 1.2 V

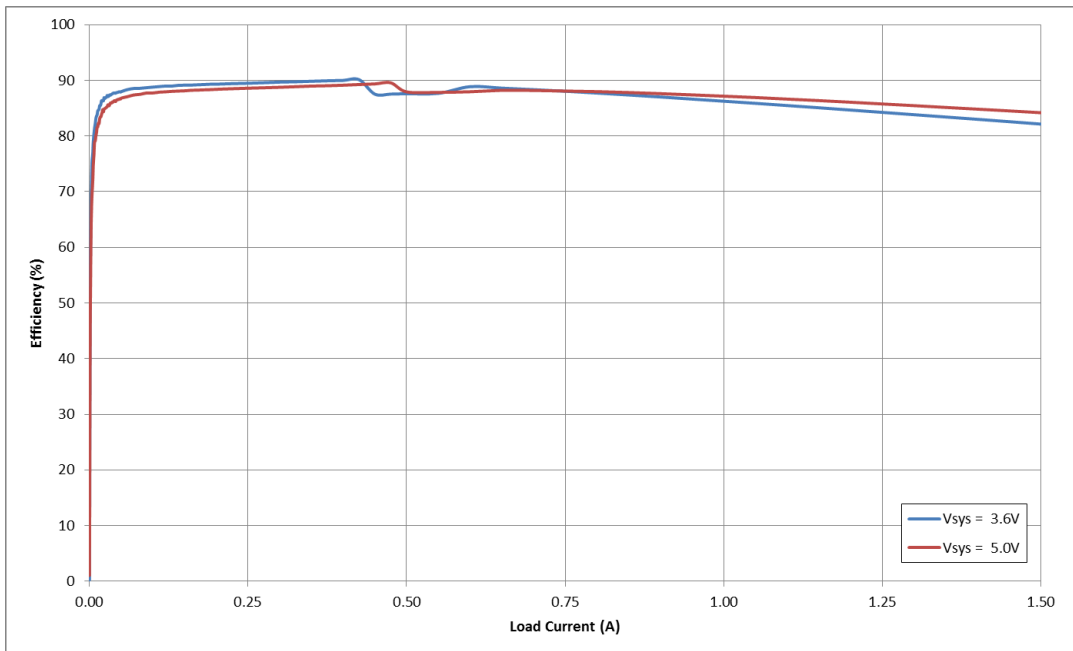

Figure 9: BUCKMEM Efficiency in AUTO Mode, V_{OUT} = 1.2 V

System PMIC for Mobile and Automotive Applications

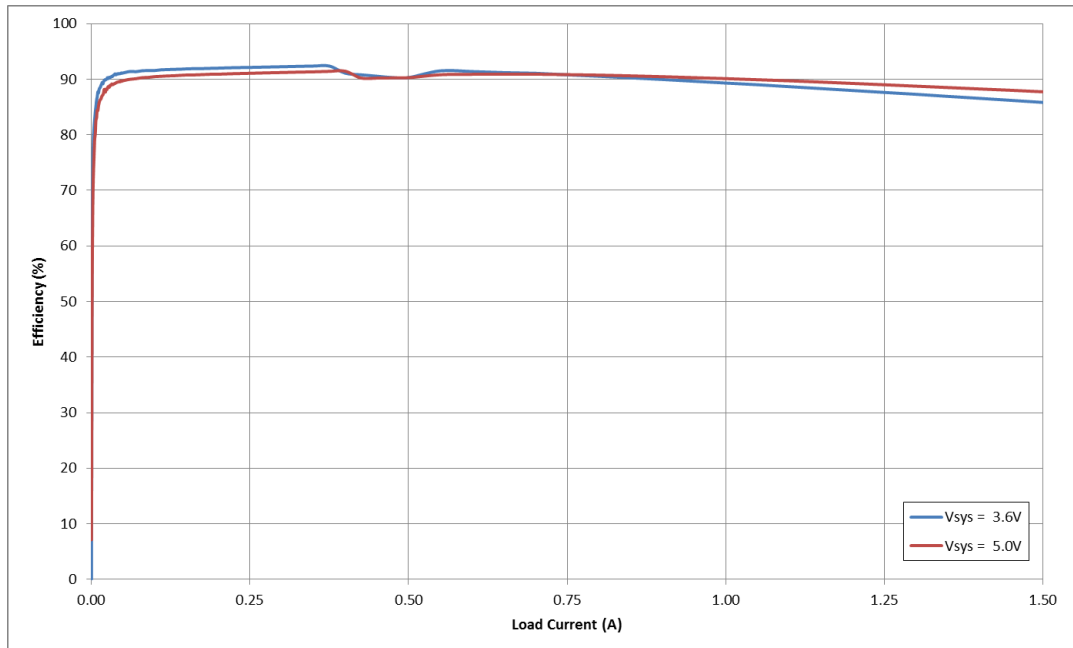

Figure 10: BUCKIO Efficiency in AUTO Mode, V_{OUT} = 1.8 V

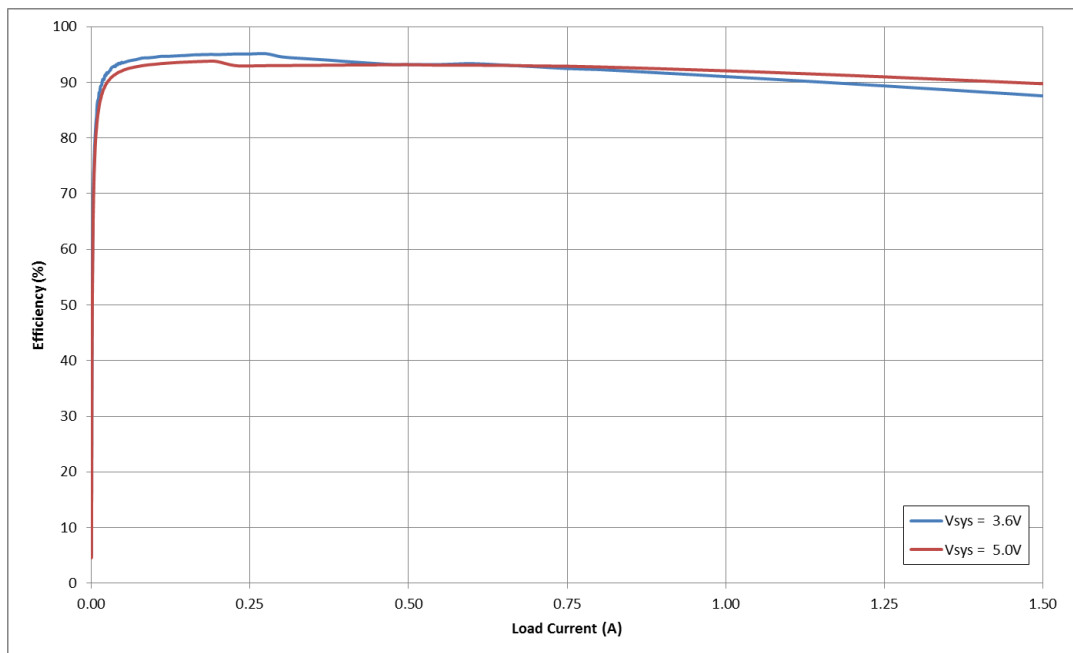

Figure 11: BUCKPERI Efficiency in AUTO Mode, V_{OUT} = 2.86 V

System PMIC for Mobile and Automotive Applications

5.9 General Purpose ADC

Table 23: General Purpose ADC, $T_J = -40\text{ °C to }+125\text{ °C}$

| Symbol | Parameter | Conditions | Min | Typ | Max | Unit |
|---------------------|---|--|------|------------|-------|------------------|
| V_{DD} | ADC reference voltage | $V_{DD} = V_{DDCORE}$ | 2.45 | 2.5 | 2.55 | V |
| | Off current | | | | 1 | μA |
| | ADC resolution | | | 10 | | bit |
| | ADC integral non linearity | | | ± 2 | | LSB |
| | ADC differential non linearity | | | ± 0.8 | | LSB |
| | ADC absolute accuracy | Note 4 | | 13 | 15 | mV |
| R_{SRC} Note 1 | Maximum source impedance | | | | 120 | $\text{k}\Omega$ |
| C_{IN} | Input capacitance | Total input capacitance | | 10.5 | | pF |
| | V_{SYS} voltage range Channel 0 | V_{SYS} minus V_{DDCORE} $V_{SYS} = 3.125 \cdot (\text{ADC}/255) + 2.5$ (Auto) $V_{SYS} = 3.125 \cdot (\text{ADC}/1023) + 2.5$ (Man) | 2.5 | | 5.5 | V |
| | ADCIN1 to 3 voltage range Channel 1 to 3 | $V_{IN} = (\text{ADC} \cdot 2.5)/255$ (Auto) $V_{IN} = (\text{ADC} \cdot 2.5)/1023$ (Man) | 0 | | 2.5 | V |
| | Internal temperature Sensor voltage range Channel 4 | $T_J = -0.398 \cdot \text{ADC} + 330$ | 0 | | 0.833 | V |
| | V_{BBAT} voltage range Channel 5 | $V_{BBAT} = (\text{ADC} \cdot 5)/1023$ | 0 | | 5.0 | V |
| | Regulator monitor voltage range Channel 8 to 10 | $V_{REG} = (\text{ADC} \cdot 5)/255$ | 0 | | 5.0 | V |
| | Inter channel isolation | Note 2 | | 60 | | dB |
| | ADCIN1,2 current source Note 3 | | -3% | 1 to 40 | 3% | μA |
| | COMP1V2 comparator level Channel 2 | | | 1.2 | | V |

Note 1 R_{SRC} is the impedance of the external source the ADC is sampling.

Note 2 80 dB for channel A2 (ADC_IN2).

Note 3 Variance guaranteed for 10 μA to 40 μA and up to 2 V output voltage.

Note 4 Excludes reference voltage variation.

System PMIC for Mobile and Automotive Applications

5.10 Internal Oscillator

Table 24: Internal Oscillator, $T_J = -40\text{ }^\circ\text{C to }+125\text{ }^\circ\text{C}$

| Parameter | Description | Conditions | Min | Typ | Max | Unit |
|-----------|-------------------------------|----------------|-----|-----|-----|------|
| | Internal oscillator frequency | After trimming | 5.7 | 6.0 | 6.3 | MHz |

5.11 POR, Reference Generation, and Voltage Supervision

Table 25: POR, Reference Generation and Voltage/Temperature Supervision, $T_J = -40\text{ }^\circ\text{C to }+125\text{ }^\circ\text{C}$

| Parameter | Description | Conditions | Min | Typ | Max | Unit |
|----------------------------------|--|------------|--------|---|------|---------------|
| V_{POR_LOWER} | Deep discharge lockout lower threshold | | | 2.0 | | V |
| V_{POR_UPPER} | Deep discharge lockout upper threshold | | | 2.3 | | V |
| $V_{DD_FAULT_LOWER}$ Note 1 | Under-voltage lower threshold | | 2.5 | 2.8 | 3.25 | V |
| $V_{DD_FAULT_LOWER_ACC}$ | Under-voltage lower threshold accuracy | | | ± 2 | | % |
| $V_{DD_FAULT_UPPER}$ Note 2 | Under-voltage upper threshold | | | $V_{DD_FAULT_LOWER} + V_{DD_HST_ADJ}$ | | V |
| V_{REF} | Reference voltage | | -1.25% | 1.2 | +1% | V |
| | V_{REF} decoupling capacitor | | | 0.22 | | μF |
| | V_{LNREF} decoupling capacitor | | | 0.22 | | μF |
| I_{REF} | Reference current resistor | | -1% | 200 | +1% | k Ω |

Note 1 During production $V_{DD_FAULT_LOWER}$ voltage is configured via OTP over the range 2.5 V to 3.25 V in 50 mV steps.

Note 2 During production the hysteresis between $V_{DD_FAULT_LOWER}$ and $V_{DD_FAULT_UPPER}$ is configured via OTP over the range 100 mV to 450 mV in 50 mV steps, the hysteresis can be further changed through control $V_{DD_HYST_ADJ}$.

5.12 Thermal Supervision

| Parameter | Description | Conditions | Min | Typ | Max | Unit |
|-----------|-----------------|------------|-----|-----|-----|------------------|
| TEMP_WARN | Thermal warning | Note 1 | 120 | 125 | 130 | $^\circ\text{C}$ |

System PMIC for Mobile and Automotive Applications

| | | | | | | |
|-----------|-----------------------|------------------------|-----|-----|-----|----|
| TEMP_CRIT | Thermal shutdown | Note 1 | 135 | 140 | 145 | °C |
| TEMP_POR | Thermal POR threshold | Note 1 | 145 | 150 | 155 | °C |

Note 1 Thermal thresholds are non-overlapping.

System PMIC for Mobile and Automotive Applications

6 Functional Description

The DA9063L provides separate power domains for the host processor, memory, and peripherals to enable a flexible low-power system design. Multiple low-power modes permit varying combinations of peripherals to be powered off to conserve battery power. Other system components, such as DRAM and FLASH memory, RF transceivers, audio codec, and companion chips, are supplied from optimized regulators designed for dedicated power requirements. The DA9063L power supplies can be programmed to default voltages via OTP and provide system-configuration flexibility by selecting the power-up sequence of the regulators and switching converters.

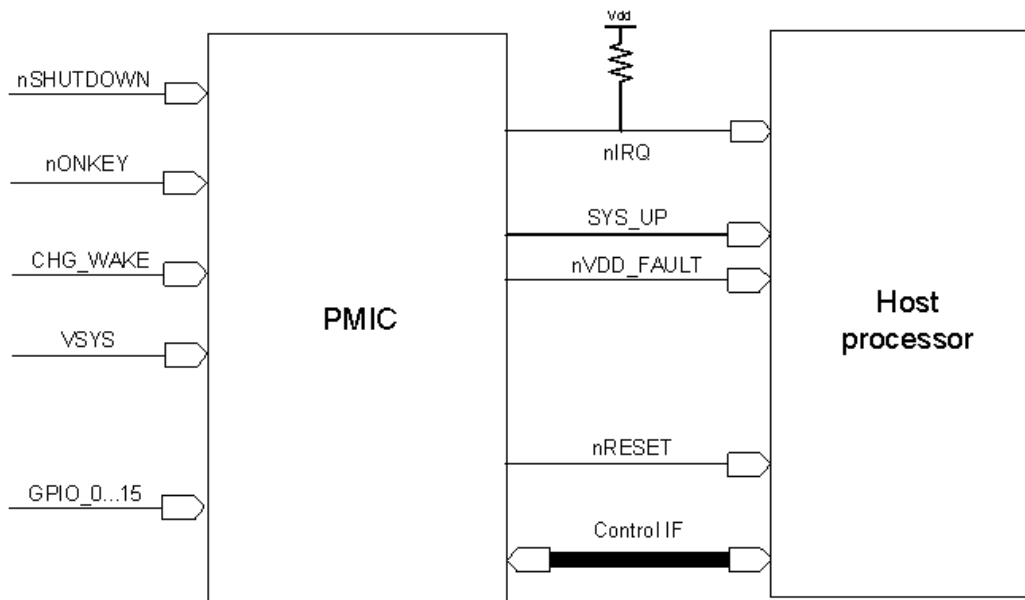

Figure 12: Control Ports and Interface

System PMIC for Mobile and Automotive Applications

6.1 Power Manager IO Ports

The power manager input ports are supplied from either the internal rail VDDCORE or VDD_IO2, selected via PM_I_V. The output ports are supplied from VDD_IO1 or VDD_IO2, selected via PM_O_V (nVDD_FAULT, GP_FB1 via GPIO controls). During the initial start-up sequence all power manager IO ports (with the exception of nRESET and nIRQ) are in a high impedance (tri-state) mode until they are configured from OTP prior to reaching POWERDOWN mode. Output ports are push-pull except for nRESET and nIRQ, which can also be configured as open-drain via PM_O_TYPE.

6.1.1 On/Off Port (nONKEY)

The nONKEY signal is a wakeup interrupt/event intended to power-on the application supplied by DA9063L. The level of the debounced signal is provided by status flag nONKEY (asserted at low level). The nONKEY unit is always enabled so that the application can be powered-on when the GPIO extender is disabled. The IRQ assertion and wakeup event can be suppressed via the interrupt mask M_nONKEY.

nONKEY provides four modes of operation selected by field nONKEY_PIN in register CONFIG_I.

Table 26: nONKEY_PIN Settings

| nONKEY_PIN | Description |
|------------|--|
| 00 | An E_nONKEY event is generated when the debounced signal from port nONKEY goes low (asserting edge). If not masked, an interrupt is signaled to the host via nIRQ (with wakeup during POWERDOWN mode). |
| 01 | If (after powering up from POWERDOWN mode) the debounced signal from port nONKEY is low after an asserting edge for less than the key-press time (selected by KEY_DELAY, default 2 s), an E_nONKEY event is generated at the releasing edge. If the signal is low for longer than selected by KEY_DELAY, the DA9063L asserts the event E_nONKEY plus control nONKEY_LOCK when it reaches the selected key-press time. |
| 10 | If (after powering up from POWERDOWN mode) the debounced signal from port nONKEY is low after an asserting edge for less than the key-press time (selected by KEY_DELAY, default 2 s), an E_nONKEY event is generated at the releasing edge. If the signal is low for longer than selected by KEY_DELAY, the DA9063L asserts the event E_nONKEY plus control nONKEY_LOCK when it reaches the selected key-press time and powers down by clearing control SYSTEM_EN. |
| 11 | If (after powering up from POWERDOWN mode) the debounced signal from port nONKEY is low after an asserting edge for less than the key-press time (selected by KEY_DELAY, default 2 s), an E_nONKEY event is generated at the releasing edge. Control SYSTEM_EN is cleared and STANDBY asserted, which triggers a partial power down from a short press. If the signal is low for longer than selected by KEY_DELAY, the DA9063L asserts the event E_nONKEY plus control nONKEY_LOCK and clear SYSTEM_EN plus STANDBY when it reaches the selected pressing time (powers down to full POWERDOWN from a long press). |

For nONKEY_PIN settings other than '00', the wakeup is not suppressed by an asserted M_nONKEY. With an asserted nONKEY_LOCK, the wakeup is only executed if the debounced nONKEY signal is asserted for more than the key-press time (selected by KEY_DELAY, default 2 s). This behaves similarly to a keypad lock since any short (unintended) pressing of nONKEY does not wake the application. If the application also has wakeup from a short nONKEY press, the host has to clear nONKEY_LOCK before entering POWERDOWN mode. In mode '10' when nONKEY key press is longer than the time selected by KEY_DELAY, SYSTEM_EN is re-asserted in mode '11'. SYSTEM_EN is re-asserted from any consecutive pressing of nONKEY. nONKEY_LOCK is

System PMIC for Mobile and Automotive Applications

automatically cleared by the DA9063L when powering up from POWERDOWN mode. POWERDOWN mode is described in Section 6.2.2.

Note

During DELIVERY mode, the functionality of nONKEY is restricted to a termination of this mode. To enable this feature, the pull-up resistor of nONKEY has to be connected to V_{SYS} . Asserting nONKEY stops the DELIVERY mode and triggers a start-up of the DA9063L.

6.1.2 Wakeup Port (CHG_WAKE)

The CHG_WAKE signal is a rising edge sensitive, wakeup interrupt/event intended to wake the DA9063L from an event on the companion charger (for example, supply insertion). The CHG_WAKE port is always enabled so that the application can be powered-on with a disabled GPIO extender. The IRQ assertion and wakeup event can be suppressed via the interrupt mask M_WAKE. During DELIVERY mode, asserting CHG_WAKE terminates this mode.

6.1.3 Hardware Reset (nOFF, nSHUTDOWN, nONKEY, GPIO14, GPIO15, WATCHDOG)

The DA9063L nOFF port is an active-low input (no debouncing) typically initiated by an asserted error detection line. It asserts nSHUTDOWN in the fault register. The sequencer asserts port nRESET, and all domains and supplies of the DA9063L except LDOCORE are disabled in a fast emergency shutdown.

The DA9063L nSHUTDOWN port is an active-low input typically asserted from a host processor (or a push button switch). It asserts nSHUTDOWN in the fault register. The sequencer asserts port nRESET and then powers down all domains in reverse sequencer order down to slot 0 and all supplies of the DA9063L except LDOCORE are disabled. HOST_SD_MODE determines if normal power sequence timing or a fast shutdown is implemented.

The DA9063L includes a third hardware reset trigger that follows the debounced nONKEY signal after being asserted for a period greater than KEY_DELAY + SHUT_DELAY. The same can be achieved by a long parallel connection of GPI14 and GPI15 to ground. The long nONKEY shutdown and GPIO14/15 shutdown are enabled by the power manager control register bits nONKEY_SD and GPI14_15_SD.

If the hardware reset was initiated by a (debounced) press of nONKEY (or GPIO14 and GPIO15 together) longer than SD_DELAY, the DA9063L initially only asserts control bit KEY_RESET in the fault register and signals a non-maskable interrupt allowing the host to clear the armed reset sequence within 1 s. If the host does not clear KEY_RESET then a shutdown to RESET mode is executed. KEY_SD_MODE determines if normal power sequence timing or a fast shutdown is implemented.

The DA9063L then waits for a valid wakeup event (for example, a key press) or starts the power sequencer automatically if AUTO_BOOT is configured.

If the WATCHDOG has been disabled, this hardware reset can be used to turn off the application in the event of a software lock-up without removing the battery. This type of reset should only be used for severe hardware or software problems as it will completely reset the processor and could result in data loss.

System PMIC for Mobile and Automotive Applications

6.1.4 Reset Output (nRESET)

The nRESET signal is an active-low output signal from DA9063L to the host processor that can either be push-pull or open drain (selected via PM_O_TYPE), which tells the host to enter the reset state. nRESET is always asserted at the beginning of a DA9063L cold start from NO-POWER and DELIVERY modes. It is asserted in ACTIVE mode before the DA9063L starts powering down to RESET mode (triggered from user, host, or an error condition detected by the DA9063L). nRESET may also be asserted (depending on nRES_MODE setting) as a soft reset before the sequencer starts powering down without progressing to RESET mode.

An assertion of nRESET from voltage supervised regulators being out-of-range can be enabled via control MON_RES (minimum assertion time 1 ms).

After being asserted, nRESET remains low until the reset timer has been started from the selected trigger signal and expires. The reset release timer trigger signal can be selected via RESET_EVENT to be EXT_WAKEUP, SYS_UP, PWR_UP, or leaving PMIC RESET state. The expiry time can be configured via RESET_TIMER from 1 ms to 1 s.

6.1.5 System Enable (SYS_EN)

SYS_EN is an input signal from the host processor to the DA9063L that enables the regulators in domain SYSTEM. The feature is enabled using GPIO8_PIN and configured as active-low or -high by GPIO8_TYPE. It asserts SYSTEM_EN and simultaneously generates an IRQ. It also triggers a wakeup event in POWERDOWN mode if enabled via GPIO8_WEN. De-asserting SYS_EN (changing from active to passive state) clears control SYSTEM_EN which triggers a power down sequence into hibernate/standby mode (without IRQ assertion or wakeup event trigger). By setting nRES_MODE, the port SYS_EN can be used as a soft reset input with the assertion of nRESET before powering down. With the exception of supplies that have the xxx_CONF control bit asserted, all regulators in power domains POWER1, POWER, and SYSTEM are sequentially disabled in reverse order. Regulators with the <x>_CONF bit set remain on but change the active voltage control registers from V<x>_A to V<x>_B (if V<x>_B is not already selected).

The control register bit SYSTEM_EN can also be used to power down domain SYSTEM by a software command. It can be read and changed via the control interfaces and can be initialized from OTP when leaving POWERDOWN mode. The DA9063L will not process any changes on port SYS_EN or register control SYSTEM_EN until the sequencer has stopped processing IDs.

6.1.6 Power Enable (PWR_EN)

PWR_EN is an input signal from the host processor to the DA9063L. The input signal can be configured as active-high or -low via GPIO9_TYPE, and to trigger a wakeup event from POWERDOWN mode if configured via GPIO9_WEN. Initialization, IRQ assertion and the direct control via register bit POWER_EN is similar to the function of SYS_EN in domain SYSTEM as described in Section 6.1.5. To ensure correct sequencing, SYSTEM_EN (SYS_EN) must be active before asserting PWR_EN/POWER_EN. When de-asserting PWR_EN/POWER_EN, the sequencer sequentially powers down POWER1 and POWER domains.

6.1.7 Power1 Enable (PWR1_EN)

PWR1_EN is an input signal from a host to the DA9063L. The input signal can be configured as active-high or -low via GPIO10_TYPE, and to trigger a wakeup event in POWERDOWN mode if enabled via GPIO10_WEN. Initialization, IRQ assertion and the direct control via register bit POWER1_EN is similar to the function of SYS_EN in domain SYSTEM as described in Section 6.1.5. POWER1 is a general purpose power domain.

System PMIC for Mobile and Automotive Applications

6.1.8 GP_FB1, General Purpose Signal 1 (EXT_WAKEUP/READY)

This port supports two different modes selected by the control PM_FB1_PIN.

Table 27: PM_FB1_PIN Settings

| PM_FB1_PIN | Description |
|------------|--|
| 0 | EXT_WAKEUP. This output signal to the host processor indicates a valid wakeup event during POWERDOWN mode. External signals that can trigger wakeup events are debounced before the EXT_WAKEUP signal is asserted. EXT_WAKEUP is released when register control SYSTEM_EN is asserted (minimum pulse duration = 500 μ s). |
| 1 | READY. The READY signal indicates on-going DVC or power sequencer activities. The READY signal is asserted (typically active-low) from the DA9063L power sequencer when the processing of IDs commences, and is released when the target power state (final sequencer slot) has been reached. READY is also asserted during DVC voltage transitions. |

The active level is configured via the control GPIO13_MODE. The logical threshold voltage is selected by GPIO13_TYPE.

6.1.9 GP_FB2, General Purpose Signal 2 (PWR_OK/KEEP_ACT)

The GP_FB2 port supports two different modes selected by the control PM_FB2_PIN.

Table 28: PM_FB2_PIN Settings

| PM_FB2_PIN | Description |
|------------|---|
| 0 | PWR_OK. In this mode the port is a regulator status indicator. The port is an open drain output asserted if none of the selected regulators are out-of-range. The regulator monitoring via ADC must be enabled and all regulators to be monitored must have supervision enabled with the selected persistence, and mask bit M_REG_UVOV must be asserted. In case at least one of the supervised regulators is out-of-range or regulator monitoring is disabled, the PWR_OK signal is low. |
| 1 | KEEP_ACT. If enabled, every assertion of the port (rising to active level edge sensitive) sets the watchdog trigger, similar to writing to bit WATCHDOG via the power manager bus. The host has to release KEEP_ACT before the next assertion during continuous watchdog supervision (if enabled). The minimum assertion and de-assertion cycle time is 150 μ s. |

The output active level (and driver type) can be configured via GP_FB2_TYPE.

Alternatively, with BCORE_MERGE = 1, FB in register BCORE1_CFG set to 0b000 and MERGE_SENSE = 0, the GP_FB2 pin becomes a voltage feedback signal for BUCKCORE.

6.1.10 GP_FB3, General Purpose Signal 3 (nVIB_BRAKE)

The GP_FB3 port supports two different modes selected by the control PM_FB3_PIN.

Table 29: PM_FB3_PIN Settings

| PM_FB3_PIN | Description |
|------------|--|
| 0 | nVIB_BRAKE disabled. |
| 1 | nVIB_BRAKE enabled. If LDO8 is configured as a vibrator motor driver, GP_FB3 can be configured to provide an external brake signal. The vibrator motor can be started or stopped by a change in the level on the nVIB_BRAKE signal. If the port is not used as a |

System PMIC for Mobile and Automotive Applications

| | |
|--|--|
| | brake command, the vibration motor runs continuously at the speed configured by VIB_SET. |
|--|--|

GP_FB3_TYPE defines the active level.

6.1.11 Supply Rail Fault (nVDD_FAULT)

nVDD_FAULT is a signal to the host processor to indicate a supply voltage (V_{SYS}) low status. Asserting nVDD_FAULT indicates that the main supply input voltage is low ($V_{SYS} < VDD_FAULT_UPPER$) and therefore informs the host processor that the power will shut down soon. The event control E_VDD_WARN is asserted and the nIRQ line is asserted (if not masked). During POWER_DOWN mode a wakeup is generated. After that the processor may operate for a limited time from the remaining battery capacity or the processor may enter a standby mode. As long as V_{SYS} does not recover, the host can re-enable the nIRQ line by asserting M_VDD_WARN or clearing E_VDD_WARN. The DA9063L starts a fault power down sequence. If V_{SYS} drops below VDD_FAULT_LOWER, the DA9063L enters RESET mode. The VDD_FAULT_LOWER threshold and the hysteresis on VDD_FAULT_UPPER are OTP configurable.

The nVDDFAULT port can alternatively be controlled by the state of the debounced V_{SYS} monitor inside the ADC (selected via GPIO12_PIN). The signal is asserted when the ADC detects three consecutive results below the configurable threshold VSYS_MON (it becomes passive after three consecutive results above VSYS_MON). This provides a variable power good signal to trigger boot activities on external ICs.

The active level/debounce, wakeup, and IO supply voltage can be selected via the controls GPIO12_MODE, GPIO12_WEN and GPIO12_TYPE, respectively.

6.1.12 Interrupt Request (nIRQ)

The nIRQ is an output signal that can either be push-pull or open drain (selected via PM_O_TYPE). If an active high IRQ signal is required, it can be achieved by asserting control IRQ_TYPE (recommended for push-pull mode). This port indicates that an interrupt-causing event has occurred and that event/status information is available in the EVENT and STATUS registers. Events are triggered by a status change at the monitored signals. When an event bit is set, the nIRQ signal is asserted (unless this interrupt is masked by a bit in the IRQ mask register). The nIRQ is not released until all event registers with asserted bits have been read and cleared. New events that occur during reading an event register are held until the event register is cleared, ensuring that the host processor does not miss them. The same happens to all events occurring while the sequencer processes time slots (that is, the generation of interrupts is delayed).

6.1.13 IO Supply Voltage (VDD_IO1 and VDD_IO2)

VDD_IO1 and VDD_IO2 are two independent IO supply rail inputs of the DA9063L that can be individually assigned to the power manager interfaces (see control bit GPI_V), power manager IOs (see control bits PM_O_V, PM_I_V) and GPIOs (bits GPIOx_TYPE). The rail assignment determines the IO voltage levels and logical thresholds, see Section 5.4. The selection of the supply rail for GPIOs is also partially used for their alternate functions, see Table 2. As an example, GPIO13_TYPE determines the supply rail when this pin is configured as the GP_FB1 output.

System PMIC for Mobile and Automotive Applications

6.2 Operating Modes

6.2.1 ACTIVE Mode

A running application is typically in ACTIVE mode. The DA9063L transitions to ACTIVE mode after the host processor performs at least one initial 'alive' watchdog write (or alternatively an initial assertion of the KEEP_ACT port) inside the target time window. If the WATCHDOG function is disabled by setting TWDSCALE to zero, the DA9063L transitions to ACTIVE mode when all of the sequencer IDs in the POWER domain are complete.

In ACTIVE mode, the PMIC core functions as LDOCORE and internal oscillator are running. Typically additional features are enabled, such as the GPADC. The DA9063L can send interrupt requests to the host via a dedicated interrupt port (nIRQ) and status information can be read from the host processor via the power manager interface. Temperature and voltages inside and outside the DA9063L can be monitored and fault conditions can be flagged to the host processor.

6.2.2 POWERDOWN Mode

The DA9063L is in POWERDOWN mode when the power domain SYSTEM is disabled (even partially). This can be achieved when progressing from NO-POWER/DELIVERY mode or by returning from ACTIVE mode. A return from ACTIVE mode is initiated by low power mode instructions from the host (for example, releasing signal SYS_EN or clearing register bit SYSTEM_EN), from the user by asserting nONKEY (if nONKEY_PIN='1x') or as an interim state during a shutdown to RESET mode.

During POWERDOWN mode LDOCORE, VREF reference voltage, the nONKEY pin, CHG_WAKE port, and the calendar counter are active. Dedicated power supplies can be kept enabled during POWERDOWN mode if their xxx_CONF bits are asserted (supply voltage settings are taken from the respective Vxxx_B registers).

GPIO ports, the GPADC, and the control interfaces also remain active in POWERDOWN mode if not configured otherwise via register PD_DIS. Disabling these blocks during POWERDOWN mode reduces quiescent current, especially if all blocks that require an oscillator clock are disabled (HS2WIRE_DIS, GPADC_PAUSE, GPI_DIS, PMCONT_DIS). If required, the application supervision by the WATCHDOG timer can be continued in POWERDOWN mode via WATCHDOG_PD. If the host will not communicate with the DA9063L during POWERDOWN mode, then the control interfaces may also be temporarily disabled (see controls HS2WIRE_DIS).

If the sequencer pointer has stopped at position PART_DOWN (inside domain SYSTEM) it results in a partial power down. When on the way down the sequencer pointer reaches position 0, relevant regulators with corresponding position 0 IDs that have cleared control Bxxx_CONF/LDOxx_CONF/xxx_SW_CONF are disabled, otherwise the regulator voltages change to the values defined in VBxxx_B/VLDOxx_B when control DEF_SUPPLY is asserted. When DEF_SUPPLY is released, slot 0 is not processed by the sequencer, hence regulators with an ID pointing to slot 0 remain unchanged. Following the next wakeup event Vxxx_A voltage levels and the sequencer power domain controls/timers are set to their default OTP values if OTPREAD_EN is asserted.

When nONKEY_SD is asserted and the key is continuously pressed for longer than the time selected by KEY_DELAY + SHUT_DELAY, it asserts KEY_RESET to indicate that the transition to RESET mode was triggered by a long nONKEY, see Section 6.1.1.

When the device is in POWERDOWN or RESET mode, asserting ECO_MODE enables low power. This is achieved internally by using a pulsed mode for VDDCORE and reference voltage generation. This maintains basic functionality but full parametric compliance is no longer guaranteed (as it affects

System PMIC for Mobile and Automotive Applications

ADC precision, buck performance, LDO voltage resolution, and so on). The pulsed mode is driven from a (free-running) low-power on-chip oscillator.

6.2.3 RESET Mode

The DA9063L is in RESET mode when a complete application shutdown is required. The RESET mode can be triggered by the user, a host processor or by an action on the DA9063L, as outlined below:

- By the user:
 - from a long press of nONKEY (interruptible by host)
 - from a long parallel assertion of GPIO14 and GPIO15 (interruptible by host)
- By pressing a reset switch connected to port nSHUTDOWN (non-interruptible)
- Forced from the host processor (non-interruptible) by:
 - asserting port nSHUTDOWN (falling edge)
 - writing to register bit SHUTDOWN
- By an error condition that forces a RESET mode (non-interruptible):
 - no WATCHDOG write (KEEP_ACT signal assertion) from the host inside the watchdog time window (if watchdog was enabled)
 - an under-voltage detected at V_{SYS} ($V_{SYS} < VDD_FAULT_LOWER$)
 - an internal die over-temperature
- Forced by the error detection line (non-interruptible):
 - by asserting port nOFF (falling edge)

The controls INT_SD_MODE, HOST_SD_MODE, and KEY_SD_MODE can be used to individually configure the shutdown sequences from an internal fault, host or user trigger. In each case, the sequence can be configured to implement either the reverse timing of the power-up sequence or an immediate transition into RESET mode, skipping any delay from the sequencer or dummy slot timers. Asserting nOFF always triggers a fast emergency shutdown. To allow the host to determine the reason for the reset, the source is recorded in FAULT_LOG (as either the KEY_RESET or nSHUT_DOWN bit). The host processor clears FAULT_LOG by writing asserted bits with a 1.

| Note |
|--|
| <ul style="list-style-type: none"> ● KEY_SD_MODE = 1 enables a full POR following a long press of ONKEY or a long assertion of GPIO14 and 15. ● In the case of an aborted OTP read, the DA9063L enters RESET mode without asserting any bits in FAULT_LOG. |

A shutdown to RESET mode begins with the DA9063L asserting the nRESET port. Then domain SYSTEM is completely powered down (sequencer position 0) at which time the device has reached RESET mode: this is a low current consumption state. The only circuits in RESET mode remaining active are LDOCORE (at a reduced level of 2.2 V), the control interfaces and GPIOs, the VREF reference, and the comparators for over-temperature and V_{SYS} level. Regulators and blocks are automatically disabled to avoid draining the battery. During the DA9063L RESET mode, the host processor can be held in a RESET state via port nRESET.

System PMIC for Mobile and Automotive Applications

When entering RESET mode, all user and system events are cleared. When leaving RESET mode, the complete DA9063L register configuration is reloaded from OTP (with the exception of AUTO_BOOT in case of a VDD_START fault).

Note

FAULT_LOG, GP_ID_10 to GP_ID_19 and other non-OTP loaded registers remain unchanged when leaving RESET mode.

nRESET is always asserted low after a cold start from NO-POWER or DELIVERY mode and can also be asserted (depending on configuration of nRES_MODE) before the sequencer starts to power down towards POWERDOWN mode.

Some reset conditions such as shutdown via register write, watchdog error, or over-temperature automatically expire (that is, are automatically cleared by the device as it shuts down). Other RESET triggers such as via port nOFF or nSHUTDOWN need to be released before the DA9063L can move from RESET to POWERDOWN mode. In the case that the application requires regulators to discharge in advance of a consecutive power-up sequence, a minimum duration of the RESET mode can be selected via RESET_DUR.

If the reset was initiated by user action from a long nONKEY key-press (or GPI14 and GPI15), bit KEY_RESET is set and the nIRQ port asserted. After 1 s the shutdown sequence is started, unless this is inhibited by the host clearing KEY_RESET within this 1 s period (by writing a 1 to the related bit in register FAULT_LOG). When the RESET condition has been removed, the DA9063L requires the presence of a good supply ($V_{SYS} > VDD_FAULT_UPPER$ and able to provide enough power) before it can start-up again and move into POWERDOWN mode.

6.2.4 DELIVERY Mode

The DELIVERY mode provides the lowest possible quiescent current, allowing connected pre-charged batteries to maintain charge prior to the end-user starting the device for the first time. During DELIVERY mode, only the nONKEY, CHG_WAKE, and the VDDREF detection circuitry is enabled.

6.2.5 NO-POWER Mode

The DA9063L enters NO-POWER mode when VDDCORE drops below the VPOR_LOWER threshold. As long as VDDCORE stays below the VPOR_UPPER threshold, an internal power-on-reset (nPOR) signal remains asserted. In this mode, only the VDDCORE threshold comparator is active. This comparator simply checks for a condition that allows the DA9063L to turn on again. When a good supply is subsequently available again on VDDREF (> 2.4 V), VDDCORE is able to rise above VPOR_UPPER and the DA9063L leaves NO-POWER mode.

6.2.6 Power Commander Mode

This is a special mode for evaluation and configuration development. In Power Commander mode, the DA9063L is configured to load the control register default values from the HS 2-WIRE interface, instead of from the OTP cells, so that un-programmed DA9063L samples will power up, allowing evaluation and verification of a proposed user configuration.

Power Commander mode is enabled by connecting TP to a 3.3 V to 5.0 V voltage.

Note

In Power Commander mode, GPI14 and 15 are configured for HS 2-WIRE interface operation (with VDDCORE as the supply) and GPO12 is configured as an output for nVDD_FAULT. Any register writes or

System PMIC for Mobile and Automotive Applications

OTP loads which can change this configuration are ignored until DA9063L has exited from Power Commander mode.

After leaving the POR state, the DA9063L informs the system that it is waiting for a programming sequence by driving nVDD_FAULT low. The software running on the PC monitors nVDD_FAULT and responds by downloading the values into the configuration registers within DA9063L. nVDD_FAULT is automatically released after the download is complete.

There are two programming sequences performed in Power Commander mode. The first takes place between RESET and POWERDOWN mode and the second between POWERDOWN and SYSTEM mode.

Note

To correctly configure DA9063L, addresses 0x0A to 0x36, 0x82 to 0xCF, and 0x104 to 0x12E should be programmed during the first sequence. Registers 0x0E, 0x82, and 0xA3 to 0xB3 should be programmed during the second sequence.

When the first programming sequence is complete, DA9063L will be in POWERDOWN mode. Progression from this mode is determined by the values programmed for SYS_EN and AUTO_BOOT. If DA9063L has been directed to progress from POWERDOWN mode then it drives pin nVDD_FAULT low for a second time to request that the SW performs the second programming sequence.

Once the second programming sequence is complete, the progress of the power-up sequence is controlled by the values loaded during the programming sequence.

The programmed configuration can be identified by reading the fuse register CONFIG_ID.

Note

During Power Commander mode, the fault detection status bit VDD_FAULT and the level at the related pin nVDD-FAULT do not match and do not indicate a low voltage level at VDDOUT. An enabled shutdown from a 5 s assertion of GPIO14/15 will be ignored during POWER Commander mode. Any nIRQ and event assertion when accessing the HS 2-WIRE interface (E_GPI14) is suppressed in this mode.

System PMIC for Mobile and Automotive Applications

6.3 Start-Up from NO-POWER Mode

6.3.1 Power-On-Reset (nPOR)

The DA9063L generates an internal power-on-reset nPOR (active low) following the initial connection of a supply to V_{DDREF} .

While the V_{DDCORE} voltage is below the threshold V_{POR_UPPER} , the internal signal nPOR is driven low and the DA9063L will not start-up. This is NO-POWER mode. When the V_{DDCORE} voltage rises above V_{POR_UPPER} , the following occur:

- The nPOR is driven high (flagged by the POR bit being set in register FAULT_LOG).
- The oscillator is enabled.
- The VREF reference is enabled.
- The complete OTP block is read and stored in the register bank.
- The DA9063L progresses into POWERDOWN mode.

From POWERDOWN mode, the DA9063L continues through the power-up sequence if either:

- the power domain SYSTEM was enabled by the input port, SYS_EN, or,
- the power domain SYSTEM was enabled in OTP settings and AUTO_BOOT was enabled.

With AUTO_BOOT disabled and the power domain SYSTEM enabled in OTP settings, a non-suppressed wakeup event allows the DA9063L to continue through the power-up sequence.

6.4 Exiting Reset Mode and Application Wakeup

Application startup requires a sufficient V_{SYS} supply, as determined by the V_{DD_START} feature, and a wake-up event.

6.4.1 V_{DD_START}

The DA9063L V_{DD_START} feature prevents endless looping of false-starts in a weakly-powered system. V_{DD_START} limits the number of automatic restart attempts to three. With reference to Figure 13:

- Figure 13(a): the PMIC starts from NO-POWER mode.
- Figure 13(b): First startup attempt. The PMIC transitions to the ACTIVE state when V_{SYS} rises above $V_{DD_FAULT_UPPER}$.
- Figure 13(c): If, during the first startup attempt, the V_{SYS} supply drops below $V_{DD_FAULT_LOWER}$ for more than 100 ms, the PMIC shuts down to the SHUTDOWN state. $V_{DD_FAULT_UPPER}$ is increased automatically by 250 mV. However, the increased $V_{DD_FAULT_UPPER}$ is limited to a maximum of 3.70 V.
- Figure 13(d): Second startup attempt. If V_{SYS} rises above the new $V_{DD_FAULT_UPPER}$ threshold, then the PMIC will power-up to the ACTIVE state.
- Figure 13(e): If, during the second startup attempt, the V_{SYS} supply drops below $V_{DD_FAULT_LOWER}$ for more than 100 ms, the PMIC shuts down to the SHUTDOWN state. $V_{DD_FAULT_UPPER}$ is increased automatically by a further 250 mV (500 mV above its original setting). However, the increased $V_{DD_FAULT_UPPER}$ is limited to a maximum of 3.70 V.
- Figure 13(f): Third startup attempt. If V_{SYS} rises above the new $V_{DD_FAULT_UPPER}$ threshold, then the PMIC will power-up to the ACTIVE state.

System PMIC for Mobile and Automotive Applications

- **Figure 13(g):** If, during the third startup attempt, the V_{SYS} supply drops below $V_{DD_FAULT_LOWER}$ for more than 100 ms, the PMIC shuts down. From then on, `AUTO_BOOT` and wake-up from non-user events are temporarily disabled. 'User events' are defined in [Table 30](#).

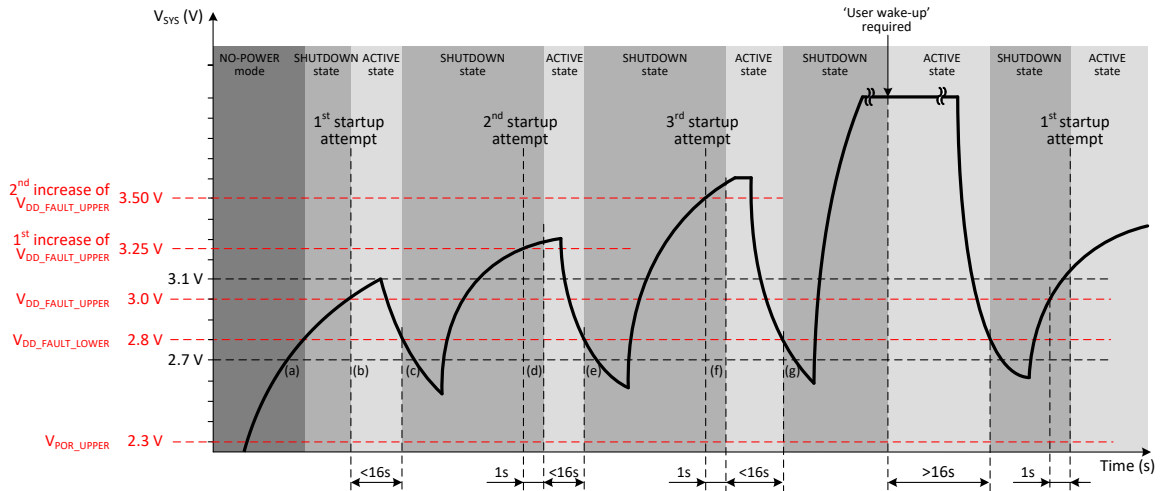

Figure 13: VDD_START Faults

NOTE

- During an attempt to restart, the entry into the ACTIVE state is delayed by 1 s.
- The ACTIVE state also includes POWER1 mode. The PMIC has the same VDD_START behavior from the POWERDOWN and SYSTEM modes as from the ACTIVE state.
- `AUTO_BOOT` and wake-up from non-user events are re-enabled after the application has successfully powered up to the ACTIVE state for more than 16 s. This also resets the start-up threshold to $V_{DD_FAULT_UPPER} + 0$ mV.

Until the host has been booted, an OTP-enabled flashing LED may be driven from GPIO11, 14, or 15 to indicate to the user that the device is supplied with (insufficient) power. When `CHG_WAKE` is connected to a charger, the VDDSTART-triggered LED flashing continues as long as an external supply is charging the battery. The flashing LED can be configured via controls `RESET_BLINKING`, `BLINK_DUR`, and `BLINK_FRQ`. After the application is running, the blinking LED can be stopped via a host register write.

6.4.2 Wake-Up Events

DA9063L offers two types of wakeup event, user events and system events (see [Table 30](#)). Non-suppressed user events (for example, `nONKEY`, `CHG_WAKE` or from GPIOs) are always processed and trigger a wakeup.

Wakeup events can be individually suppressed by setting the related `nIRQ` mask bit. When `nONKEY_LOCK` is asserted a wakeup requires the debounced signal from `nONKEY` to be low for a time longer than the configured `KEY_DELAY`. It is not recommended to mask system events, instead disable the unwanted event sources (for example, GPIOs, GPADC, 1.2 V comparator). The wakeup from GPIOs (or selected alternate features that use a shared GPI event) has to be enabled via `GPI<x>_WEN`.

System PMIC for Mobile and Automotive Applications

After a valid wakeup condition is detected, a subset of the OTP configuration is read and the values are used to reconfigure the regulator voltage registers V_{xxx_A} , the power domain enable settings (if not suppressed via $SYSTEM_EN_RD$) and the sequencer timer.

DA9063L then asserts the EXT_WAKEUP signal towards the host processors and configures regulators with an ID pointing at slot 0 to their target state. If the power domains are not pre-enabled from OTP settings, the host processor must control further application start-up (via the power domain enable ports, SYS_EN , PWR_EN and $PWR1_EN$). Alternatively the DA9063L continues powering-up the OTP-enabled domains via the power domain sequencer, but the power sequencer will not start to enable the system supplies unless $SYSTEM_EN$ is asserted.

Progression to ACTIVE mode requires assertion of $POWER_EN$ from the host via port PWR_EN , a register write, or enabled in OTP. After starting the WATCHDOG timer the host processor must assert the WATCHDOG bit within the configured time window. If this does not happen, the state-machine terminates ACTIVE mode and returns to RESET mode.

Table 30: Wakeup Events

| Signal : Event | Wakeup | User Event | System Event | IRQ |
|--|--------|------------|--------------|-----|
| V_{SYS} monitor : E_VDD_MON | X | | X | X |
| VDD_FAULT pre-warning : E_VDD_WARN | X | | X | X |
| Voltage comparator flipped : $E_COMP1V2$ | X | | X | X |
| Pressed On key : E_nONKEY | X | X | | X |
| Wakeup from companion charger : E_WAKE | X | X | | X |
| LDO over current detect : E_LDO_LIM | X | | X | X |
| Regulator voltage out-of-range : E_REG_UVOV | X | | X | X |
| Critical junction temperature : E_TEMP | X | | X | X |
| Power sequencing ready : E_SEQ_RDY | | | X | X |
| Voltage ramping ready : E_DVC_RDY | | | X | X |
| Manual ADC result ready : E_ADC_RDY | | | X | X |
| GPIOs passive to active transition : E_GPIOx | X | X | | X |
| ADC 1, 2, 3 threshold : via GPIO, 1, 2 | X | | X | X |
| SYS_EN , PWR_EN , $PWR1_EN$ (passive to active transition) : via GPIO8, 9, 10 | X | | X | X |
| HS 2-WIRE interface : via GPIO14 | X | | X | X |

System PMIC for Mobile and Automotive Applications

6.5 Power Supply Sequencer

The DA9063L power supplies are enabled with a sequencer that contains a programmable step timer, a programmable ID array of slot pointers, and four predefined pointers (SYSTEM_END, POWER_END, MAX_COUNT, and PART_DOWN), as illustrated by Figure 14. The sequencer is able to control up to 32 IDs (6 bucks, 5 LDOs, 5 external FET/IC controls, a Wait ID (GPI10), and an ID to activate power down settings), which can be grouped to three power domains.

The power domains have configurable size and their borders are described by the location pointers SYSTEM_END, POWER_END, and MAX_COUNT.

The lowest level power domain SYSTEM starts at step 1 and ends at the step that is described by the location pointer SYSTEM_END. The second level domain POWER starts at the successive step and ends at POWER_END. The third level domain POWER1 starts at the consecutive step and ends at MAX_COUNT. The values of pointer SYSTEM_END, POWER_END, and MAX_COUNT are predefined in OTP registers and should be configured as SYSTEM_END < POWER_END < MAX_COUNT.

The domain system can be thought of as the minimum set of supplies required to enable the core of the target system.

If the control OTPREAD_EN is enabled, the regulator voltages, sequence domain enables (if not suppressed via control SYSTEM_EN_RD), and the sequence timer are reset to their OTP values during the transition from power down to system.

The second level domain POWER includes supplies that are required on top to trigger the application and set the DA9063L into ACTIVE mode. POWER1 can be understood as one of the POWER domains that can be used for further sequenced control of supply blocks during ACTIVE mode (for example, for a sub-application like WLAN or a baseband chipset).

| Note |
|---|
| It is recommended that the system is configured to reach ACTIVE mode before running applications. |

6.5.1 Powering Up

All buck converters and LDOs of DA9063L have a unique sequencer ID. The power-up sequence is defined by an OTP register bank that contains a series of supplies (and other features), each of which point to a selected sequencer time slot. Several supplies can point to the same time slot which is therefore enabled in parallel by the sequencer. Time slots that have no IDs pointing at them are dummy steps that do nothing but insert a configurable time delay (marked in Figure 14 as D). Supplies/IDs that do not point to a sequencer time slot between 1 and MAX_COUNT are not enabled by the power sequencer but can be controlled individually by the host (via the power manager interface).

During power-up, the sequencer starts at slot 0. If DEF_SUPPLY is asserted, it checks all regulators for an ID pointing to slot 0. Cleared LDOxx_AUTO/BUCKxxx_AUTO/xxx_SW_AUTO bits are configured by setting the related control Bxxx_CONF/LDOxx_CONF/xxx_SW_CONF, otherwise the regulator is enabled. To minimize inrush currents, it is recommended to enable no more than a single default regulator via DEF_SUPPLY. During power-up, the regulator output voltage is taken from the VBxxx_A/VLDOxx_A registers. During power-down, regulators with a cleared control in Bxxx_CONF/LDOxx_CONF/xxx_SW_CONF are disabled, otherwise the regulator voltage is changed to VBxxx_B/VLDOxx_B when entering slot 0. When DEF_SUPPLY is released, slot 0 is not processed by the sequencer (regulators with an ID pointing at slot 0 remain unchanged).

System PMIC for Mobile and Automotive Applications

The progression of the sequencer to slot 1 is dependent on certain conditions:

- If AUTO_BOOT and SYSTEM_EN are both asserted (via port, by register write or in OTP), the sequencer asserts the READY signal (if GP_FB1 is so configured) and then continues by processing slot 1.
- If AUTO_BOOT is not asserted, the sequencer remains in a holding start state, waiting for either:
 - the assertion of SYSTEM_EN, or,
 - any other wakeup event if SYSTEM_EN is already enabled.

All supplies (and other sequenced features) that are pointing at slot 1 are then processed. This is similar to the processing of slot 0 with the exception that DEF_SUPPLY has no effect on slots apart from slot 0. From slot 1, the sequencer progresses until it reaches the position of pointer SYSTEM_END. At this point, all IDs of the first power domain SYSTEM are enabled and, if POWER_EN is not asserted, the DA9063L releases the READY signal (in combination with optional assertion of E_SEQ_RDY).

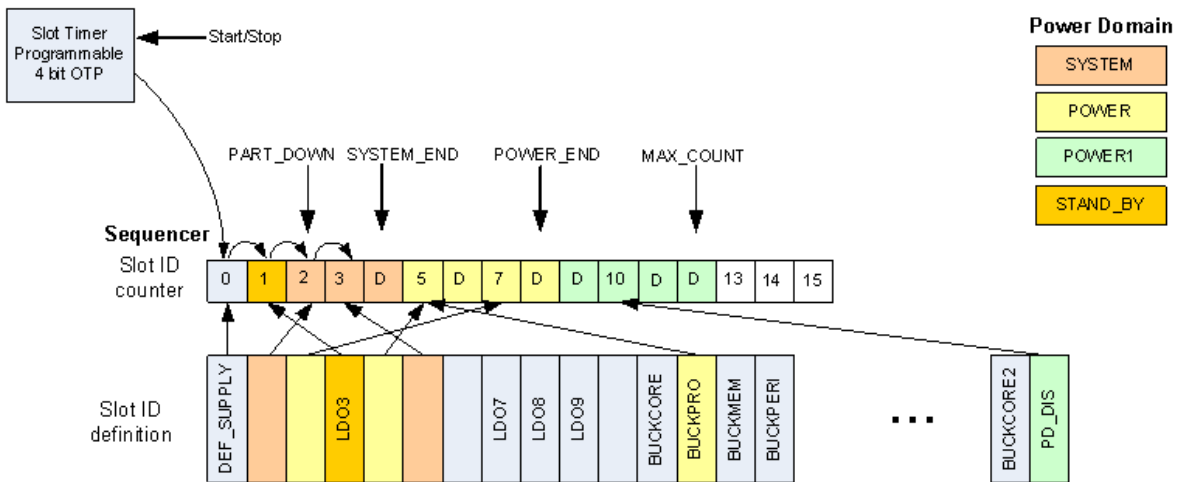

Figure 14: Assignment of Actions to Sequencer Slot IDs

Table 31: Power Sequencer Controlled Actions

| Action | Sequencer Time Slot |
|-------------------|---------------------|
| Control LDO3 | LDO3_STEP |
| Control LDO7 | LDO7_STEP |
| Control LDO8 | LDO8_STEP |
| Control LDO9 | LDO9_STEP |
| Control LDO11 | LDO11_STEP |
| Control BUCKCORE1 | BUCKCORE1_STEP |
| Control BUCKCORE2 | BUCKCORE2_STEP |
| Control BUCKPRO | BUCKPRO_STEP |
| Control BUCKIO | BUCK_IO_STEP |
| Control BUCKMEM | BUCKMEM_STEP |

System PMIC for Mobile and Automotive Applications

| Action | Sequencer Time Slot |
|---------------------------------|---------------------|
| Control BUCKPERI | BUCKPERI_STEP |
| Assert/Release GPIO2 | GP_RISE1_STEP |
| Release/Assert GPIO2 | GP_FALL1_STEP |
| Assert/Release GPIO7 | GP_RISE2_STEP |
| Release/Assert GPIO7 | GP_FALL2_STEP |
| Assert/Release GPIO8 | GP_RISE3_STEP |
| Release/Assert GPIO8 | GP_FALL3_STEP |
| Assert/Release GPIO9 | GP_RISE4_STEP |
| Release/Assert GPIO9 | GP_FALL4_STEP |
| Assert/Release GPIO11 | GP_RISE5_STEP |
| Release/Assert GPIO11 | GP_FALL5_STEP |
| Wait for active state at GPI 10 | WAIT_STEP |
| PD_DIS | PD_DIS_STEP |

On completion of domain SYSTEM, the sequencer waits for POWER_EN to be asserted (via the PWR_EN port, a register write or in OTP). When POWER_EN is asserted, the signal READY is asserted (if not already asserted) and regulators/IDs of domain POWER are enabled sequentially. The sequencer stops at the position of pointer POWER_END. At this point it also: releases the READY signal (if POWER1_EN is not asserted); optionally asserts E_SEQ_RDY; enables the initial WATCHDOG timer and waits for the first associated alive feedback from the host processor. After this, the start-up of the DA9063L progresses into ACTIVE mode.

A third power domain, POWER1, can be enabled via POWER1_EN (asserted by PWR1_EN port, register write or in OTP). It enables all consecutive IDs until the position of pointer MAX_COUNT has been reached. The READY signal is asserted as long as IDs are processed (if enabled) and E_SEQ_RDY is asserted when reaching MAX_COUNT.

System PMIC for Mobile and Automotive Applications

6.5.2 Power-Up Timing

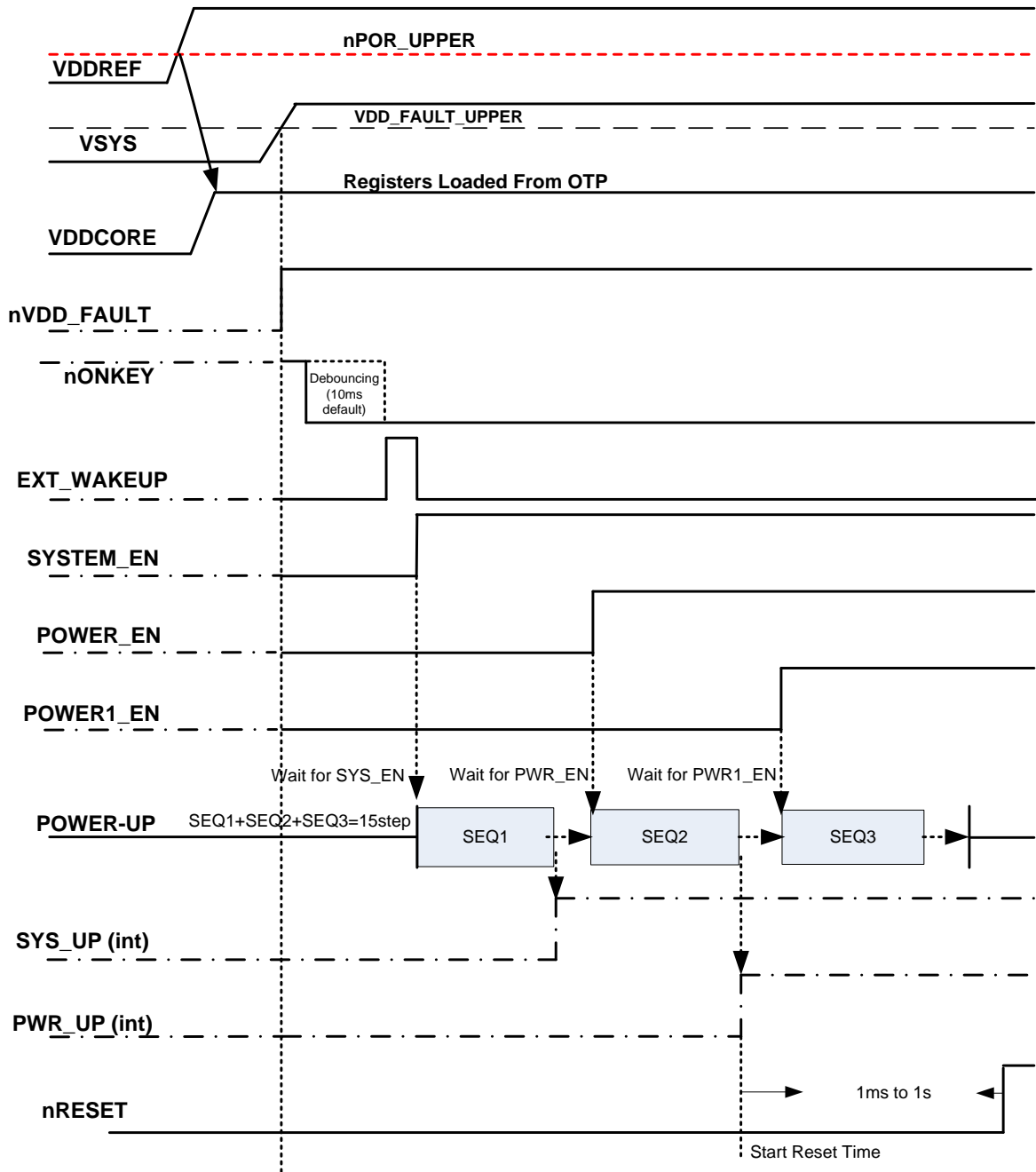

Figure 15: Power-Up Timing

System PMIC for Mobile and Automotive Applications

6.5.3 Programmable Slot Delays

The delay between the slots of a sequence is controlled via the programmable value of SEQ_TIME in register SEQ_TIMER. This has a default delay of 128 μ s per slot (min. 32 μ s, max. 8 ms). The delay time between individual supplies can be extended by leaving a consecutive slot(s) with no IDs pointing to it: these are dummy slots. The dummy slots have an independent delay configured by SEQ_DUMMY. These delay times, in register SEQ_TIMER, are (re-)loaded from OTP every time domain SYSTEM begins to power-up.

6.5.4 Powering Down

When the DA9063L is powering down, the sequencer disables the supplies in reverse order and timing, asserts READY during sequencing, and triggers E_SEQ_RDY on reaching the target sequencer slot. Supplies that are configured to stay on (LDO<x>_CONF, B<x>_CONF, xxx_SW_CONF bit is set) are not disabled and are configured with the voltage setting from register VB<x>_B/VLDO<x>_B when the related time slot/ID is processed. The state of the regulators that are enabled for GPI control will not be changed by the sequencer when processing the related ID. This also applies for the selection of the related V<x>_A or V<x>_B voltage control register in case a regulator is enabled for GPI voltage selection.

If powering down is initiated by clearing POWER1_EN, the sequencer stops controlling IDs before the domain pointer POWER_END is reached. If POWER_EN is cleared, the domain POWER1 is powered down followed by POWER before the sequencer reaches pointer SYSTEM_END. These modes are used to temporarily disable optional features of a running application for reduced power (sleep mode).

If SYSTEM_EN is cleared the sequencer processes all IDs lower than the pointer position down to slot 0. The sequencer can be forced to stop the intended power down sequence prior to maturity at pointer position PART_DOWN via an asserted control STANDBY (PART_DOWN has to point into domain SYSTEM). In these cases the power sequencer has reached the application's POWERDOWN mode (hibernate/standby), which enables the option to reset regulator settings for the consecutive power-up sequence from OTP (enabled by OTPREAD_EN).

Wakeup events are enabled when the sequencer reaches slot 0 or pointer PART_DOWN (ignored outside of POWERDOWN mode). The assertion of nIRQ from events during POWERDOWN mode may be delayed until ACTIVE mode is reached the next time if configured by nIRQ_MODE. During processing slot 0, all supplies pointing into this step with a cleared control Bxxx_CONF/LDOxx_CONF/xxx_SW_CONF are disabled, otherwise the regulator voltage is changed to VBxxx_B/VLDOxx_B (if bit DEF_SUPPLY is asserted). Asserting control register bit SHUTDOWN first powers down to slot 0 and then forces the DA9063L into RESET mode. Autonomous features such as the Auto-ADC measurement can be disabled temporarily for POWERDOWN mode via register PD_DIS. The timing for processing PD_DIS can be defined by selecting a step inside the sequence. Features asserted in PD_DIS are (re-)enabled when PD_DIS is processed during a power-up sequence.

Control nRES_MODE enables the assertion of nRESET before executing a power-down sequence and starting the reset timer during the consecutive powering up. This is also true for partial POWERDOWN mode, when the sequencer powers down to pointer position PART_DOWN. The reset timer starts to run from the selected RESET_EVENT and releases the nRESET port after the reset timer expires.

System PMIC for Mobile and Automotive Applications

6.5.5 User Programmable Delay

A conditional mode transition can be achieved using ID WAIT_STEP. If pointing into the power sequence the progress of an initiated mode transition can be synchronized, for example with the state of a host. This is indicated by toggling the signal at GPI10 to its configured active state. A safety timeout of 500 ms can be selected in TIME_OUT to trigger a power-down to RESET mode (including the assertion of WAIT_SHUT inside register FAULT_LOG) if E_GPI10 is not asserted in time. The ID WAIT_STEP provides an alternate timer mode, selected by WAIT_MODE and configured by WAIT_TIME, which provides a delay timer for a selected sequencer step. To enable symmetric sequence behavior, ID WAIT_STEP should not share a sequencer slot with other IDs. In the case of a shutdown sequence to RESET mode any waiting/delay at ID WAIT_STEP is skipped.

System PMIC for Mobile and Automotive Applications

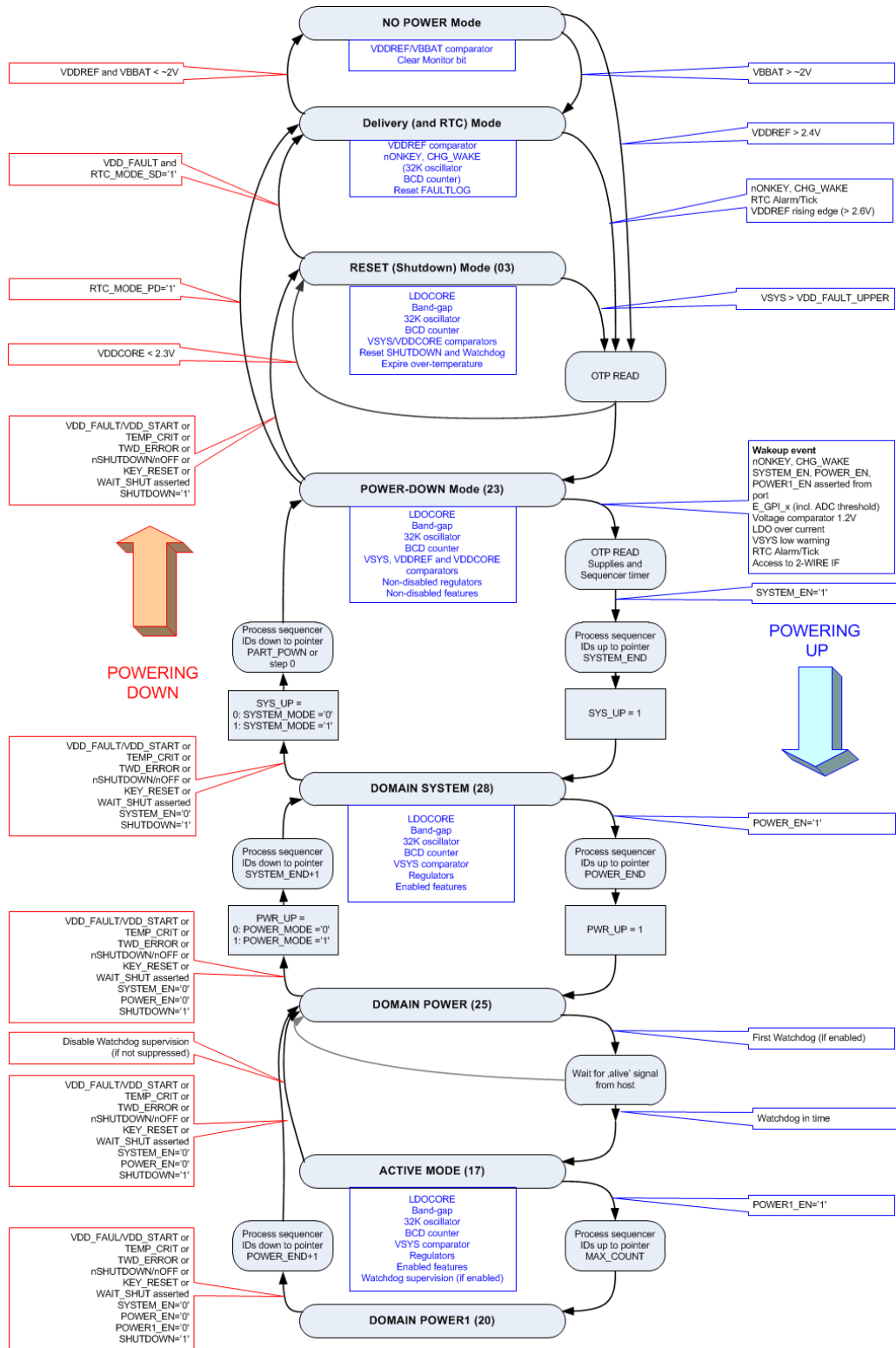

Figure 16: Power Mode Transitions

System PMIC for Mobile and Automotive Applications

6.6 System Monitor (Watchdog)

After powering up domain POWER, the DA9063L can initiate a watchdog monitor function. The host processor must write a 1 within a configured t_{WD_MAX} time into control WATCHDOG, thereby indicating that the host is alive. If the host does not write 1 to this watchdog bit within the t_{WD_MAX} time, the DA9063L asserts TWD_ERROR in the FAULT_LOG register and powers down to RESET mode.

After this first write, the host must continue to write to this watchdog bit within the configured time or DA9063L powers down as described above. The time window has a minimum time t_{WD_MIN} fixed at 256 ms and a maximum time t_{WD_MAX} , nominally 2.048 s. The t_{WD_MAX} value can be extended by multiplying the nominal t_{WD_MAX} by the value of register bits TWDSSCALE. TWDSSCALE is used to extend the t_{WD_MAX} time by x1, x2, x4, x8, x16, x32, or x64.

Once in the ACTIVE state, the DA9063L continues to monitor the system unless it is disabled by setting TWDSSCALE to zero. When powering down from ACTIVE mode, the watchdog monitor is stopped unless it enters POWERDOWN mode via WATCHDOG_PD.

If the WATCHDOG register bit is set to a 1 within the time window, the watchdog monitor resets the timer, sets the watchdog bit back to zero (this bit is always read as zero) and waits for the next watchdog signal. The watchdog trigger can also be asserted from the host by asserting KEEP_ACT in hardware. This mode is selected with control PM_FB2_PIN and removes the above requirement for the periodic setting of the watchdog bit.

The watchdog feature can be disabled by setting TWDSSCALE to zero.

6.7 GPIO Extender

The DA9063L includes a GPIO extender that provides up to 16 V_{DDREF} -tolerant general purpose input/output ports, each controlled via registers from the host, see [Table 32](#) and [Figure 17](#).

The GPIO ports are pin-shared with ports from GPADC, HS 2-WIRE-interface and signals from the power manager. Configuration settings and events from GPIx ports are also shared with alternative features. For example, if GPIO1_PIN is configured to be ADCIN2, exceeding the configured ADC thresholds triggers a GPI1 event that generates a maskable GPI1 interrupt. The GPI active High/Low setting from the GPIOx_TYPE register and the selection of pull-up resistor is also applicable to the alternative port functions selected via GPIOx_PIN (for example, SYS_EN, PWR_EN and PWR1_EN). This is also true for GPIOx_WEN, which is used to enable triggering of a wakeup event (ADCIN1, ADCIN2, ADCIN3, SYS_EN, PWR_EN, PWR1_EN, HS 2-WIRE interface). When GPI ports are enabled (including being enabled by changing the setting of GPIOx_PIN), the GPI status bits are set to their non-active state. This ensures that any signals that are already active are detected and immediately generate any appropriate events.

In ACTIVE and POWERDOWN mode, the GPIO extender can continuously monitor the level of ports that are selected as general purpose inputs. GPIs are supplied from the internal rail VDDCORE or VDD_IO2 (selected via GPI_V) and can be configured to trigger events in active-high or active-low mode. The input signals can optionally be debounced (configurable via control DEBOUNCING, 10 ms default) and the resulting signal level is reflected by the status register GPIx. When the status has changed to its configured active state (edge sensitive) the assigned event register is set and the nIRQ signal is asserted (unless this nIRQ is masked). GPIs can be individually configured to generate a system wakeup via GPIxx_WEN.

If enabled via regulator controls LDOx_GPI/Bxxx_GPI, the ports GPI1, GPI2, and GPI13 can be used to enable/disable regulators (that is, controlling LDOx_EN/Bxxx_EN). The GPI active level is selected via the related GPIxx_TYPE control. GPI ports that are selected for this hardware control of one or more regulators do not generate events (nIRQ). GPI1, 2, and 13 can alternatively be selected to

System PMIC for Mobile and Automotive Applications

toggle the VLDOx_SEL/VBxxx_SEL. Apart from changing the regulator output voltage, this feature also allows hardware control of regulator mode (sync/sleep mode) via selection of the settings contained in xxx_SL_A and xxx_SL_B (but only for those bucks configured with Bxxx_MODE = 00). When a regulator is controlled via GPI, its enable and voltage register selection are no longer controlled by the power sequencer (processing the related ID only affects non-GPI controlled functionality). However, these settings can still be changed via register writes from the control interface.

Events on GPI10 can be used to control the progress of the power sequencer. Processing ID WAIT_STEP causes the sequencer to wait until GPI10 changes into its active state.

Note

Supplies directly enabled/disabled from GPI1, 2, or 13 have to be excluded from the power sequencer control (IDs of these supplies should point into a slot higher than MAX_COUNT)

If defined as an output, GPO0, 1, 3 to 6, 10 to 11, and 13 to 15 can be configured to be open-drain instead of push-pull. The supply rail can be individually selected from either VDD_IO1 or VDD_IO2. By disabling the internal 120 kΩ pull-up resistor when in open-drain mode, the GPO can also be supplied from an external rail (see registers CONFIG_K and CONFIG_L). The GPO output state reflects the respective register bit GPIOx_MODE.

When configured as outputs, GPO 2, 7, 8, 9, and 11 can be controlled by the DA9063L power sequencer. Five pairs of level asserting and level releasing IDs (GP_RISE1_STEP/ GP_FALL1_STEP to GP_RISE5_STEP/GP_FALL5_STEP) may be assigned individually to slots of the power sequencer, which trigger the configured level transition on the GPOs when processing the related ID during powering up (see [Table 31](#) for assignments). The configured level change is inverted when processing the IDs during powering down. These are intended for use as enable signals either for external regulators or other devices in the system.

When the GPIO unit is off (POR), all ports are configured as open drain output with high level (pass device switched off, high impedance state). When leaving POR, the pull-up or pull-down resistors are configured from registers CONFIG_K and CONFIG_L. When the GPIO unit is temporarily disabled by the power sequencer (via GPI_DIS or PMCONT_DIS) level transitions on inputs are no longer detected and I/O drivers keep their configuration and programmed levels.

GPO12 can be driven by the state of VDD_MON to provide an active high 'Power good' signal (selected via GPIO12_PIN).

GPO10, 11, 14, and 15 are extended power GPO ports, where the maximum sink current is 11 mA and the maximum source current is 4 mA. This enables driving LEDs. The output ports GPO11, GPO14, and GPO15 can be toggled with a configurable periodic pulse configured via BLINK_FRQ and BLINK_DUR and include an optional PWM control. The generated PWM signals have a duty cycle from 0 % to 100 % with a repetition frequency of 21 kHz and 95 steps (using one 2 MHz clock for each step). The duty cycle is set by the controls GPO11_PWM, GPO14_PWM, and GPO15_PWM, with any value larger than 0 enabling the PWM mode of operation. The PWM control can also be made to dim the brightness between its current value and a new value at a rate of 32 ms per step. Selection of this mode is set by GPO11_DIM, GPO14_DIM, and GPO15_DIM. When set to zero the PWM ratio immediately changes. This creates a common anode tricolor LED brightness control. Flashing is driven from the crystal oscillator when control CRYSTAL has been asserted; otherwise an auxiliary on-chip oscillator is used.

LEDs are recommended to be low-side driven (using the GPIOs in sink mode) which is configured by setting GPIOx_MODE = 1.

System PMIC for Mobile and Automotive Applications

Table 32: GPIO Overview

| GPIO | Alternate Port | Alternate Port Shared Resources | GPIO Wakeup | Remark |
|------|----------------|--|--------------------------------------|---|
| 0 | ADCIN1 | E_GPIO0, M_GPIO0, GPIO0_MODE | x | Auto measure ADC |
| 1 | ADCIN2 | E_GPI1, M_GPI1, GPIO1_MODE | Regulator control x (in other modes) | Auto measure ADC/1.2V comparator, HW control of regulator |
| 2 | ADCIN3 | E_GPI2, M_GPI2, GPIO2_MODE | Regulator control x (in other modes) | Auto measure ADC, HW control of regulator/ power sequencer controlled GPO |
| 3 | | | x | |
| 4 | CORE_SWS | | x | Buck remote feedback voltage sense |
| 5 | | | x | |
| 6 | PERI_SWS | | x | Buck remote feedback voltage sense |
| 7 | | | x | Power sequencer controlled GPO |
| 8 | SYS_EN | E_GPI8, M_GPI8, GPIO8_TYPE, GPIO8_WEN, GPIO8_MODE | x | Power sequencer controlled GPO |
| 9 | PWR_EN | E_GPI9, M_GPI9, GPIO9_TYPE, GPIO9_WEN, GPIO9_MODE | x | Power sequencer controlled GPO |
| 10 | PWR1_EN | E_GPI10, M_GPI10, GPIO10_TYPE, GPIO10_WEN, GPIO10_MODE | x | High power GPO, input signal for ID WAIT |
| 11 | | | x | High power GPO (LED flashing/PWM), Power Sequencer controlled GPO |
| 12 | nVDD_FAULT | GPIO12_TYPE, GPIO12_WEN, GPIO12_MODE | x | VDD_MON state controlled GPO (POWER_GOOD) |
| 13 | GP_FB1 | GPIO13_TYPE, GPIO13_MODE | Regulator control x (in other modes) | HW control of regulator |
| 14 | DATA | E_GPI14, M_GPI14, GPIO14_TYPE, GPIO14_MODE | x | High power GPO (LED flashing/PWM), Reset via long assertion in parallel with GPI15, 2nd 2-WIRE or DVC Control Interface |
| 15 | CLK | | x | High power GPO (LED flashing/PWM), Reset via long assertion in parallel with |

System PMIC for Mobile and Automotive Applications

| GPI O | Alternate Port | Alternate Port Shared Resources | GPI Wakeup | Remark |
|-------|----------------|---------------------------------|------------|--|
| | | | | GPI14, 2nd 2-WIRE or DVC Control Interface |

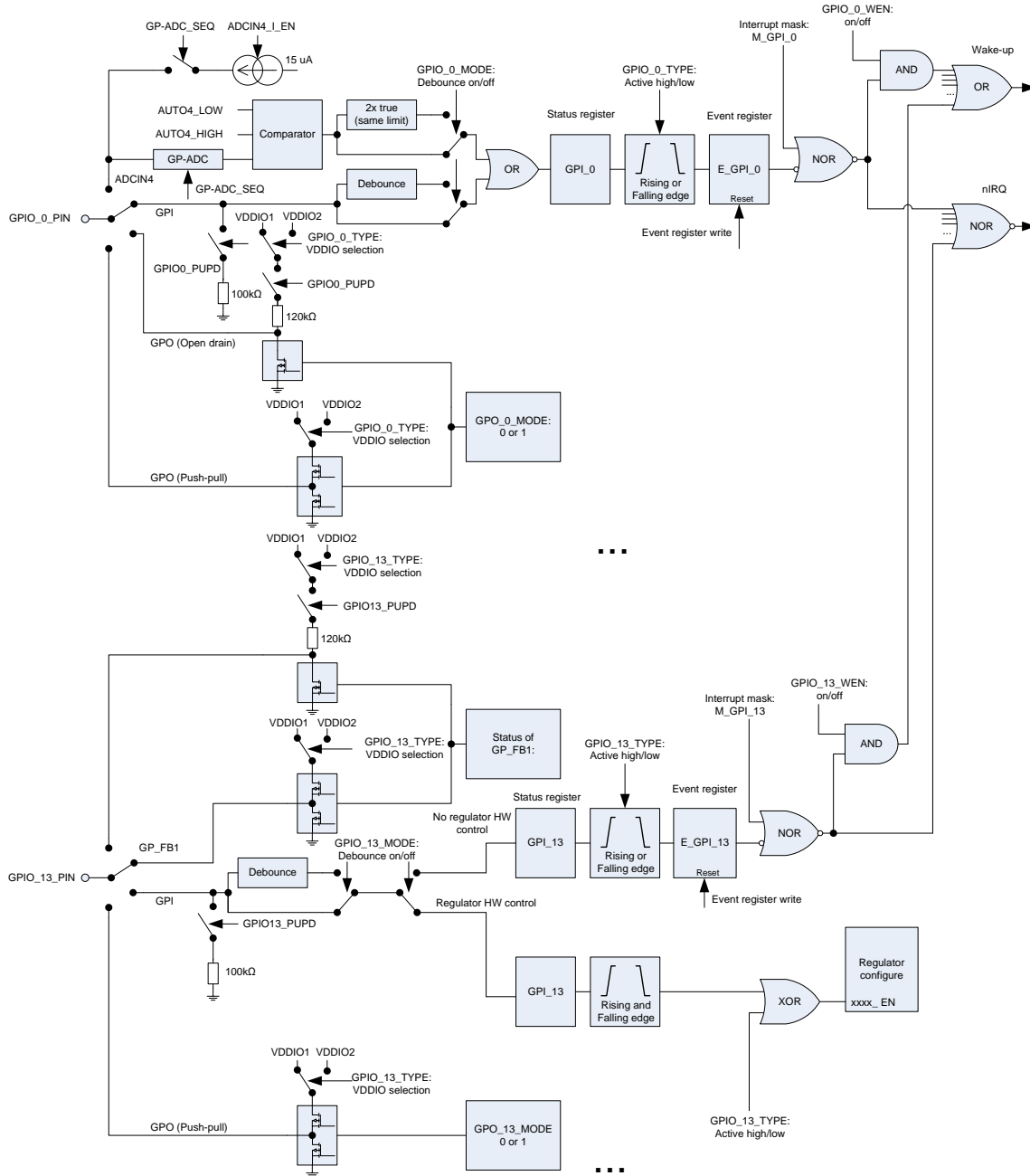

Figure 17: GPIO Principal Block Diagram (Example Paths)

System PMIC for Mobile and Automotive Applications

6.8 Control Interface

The DA9063L is register controlled by the host software. Data is shifted into or out from DA9063L under the control of the host processor that also provides the serial clock. The interface is usually only configured once from OTP values, which are loaded during the initial start-up. The interface configuration can be changed by the host. However, care must be taken that changes are not made while the interface is active. If enabled, IF_RESET forces a reset of all control interfaces when port nSHUTDOWN is asserted.

The HS 2-WIRE interface is the serial control bus. It consists of DATA (data line) and CLK (clock line) and can be used as an independent control interface for data transactions between the DA9063L and a second host processor. The DA9063L HS 2-WIRE interface has a configurable 8-bit write address (default 0xB4) and a configurable read address (default 0xB5). For details of configurable addresses see control IF_BASE_ADDR in Section A.4.2 The interface is enabled if DATA was selected via configuration control GPIO14_PIN. The bus lines have to be pulled high by external pull-up resistors (2 kΩ to 20 kΩ). GPIO14_TYPE defines the supply rail of the interface (used for input logic levels and the internal pull-up resistors). The controls GPIO15_PIN and GPIO15_WEN are disabled when enabling the interface via GPIO14_PIN.

When the interface receives a read or write command that includes a matching slave address, the DA9063L can trigger the assertion of nIRQ and an optional wakeup event (enabled via GPIO14_WEN). If the nIRQ assertion from interface access is enabled (E_GPI14), it should be masked as long as the HS 2-WIRE is in use. This nIRQ cannot be cleared via the HS 2-WIRE interface because every interface access triggers a re-assertion.

High speed mode at 3.4 MHz can be enabled either via master code or continuously via HS_IF_HSM, but it does not support slope control for minimum t_{fDA} specification.

The 2-wire interface is open-drain, supporting multiple devices on a single line. The bus lines must be pulled high by external pull-up resistors (2 kΩ to 20 kΩ). The attached devices only drive the bus lines low by connecting them to ground. As a result, two devices cannot conflict if they drive the bus simultaneously. In standard/fast mode, the highest frequency of the bus is 400 kHz. The exact frequency can be determined by the application and does not have any relation to the DA9063L internal clock signals. The DA9063L follows the host clock speed within the described limitations and does not initiate any clock arbitration or slow down. Control TWOWIRE_TO enables an automatic interface RESET that is triggered when the clock signal ceases to toggle for >35 ms (compatible with SMBus $T_{TIMEOUT}$).

The interface supports operation compatible with Standard, Fast, Fast-Plus and High Speed modes of the I²C-bus specification Rev 03 (UM10204_3). Bus clear, in the case of the DATA signal being stuck low, is achieved after receiving 9 clock pulses. Operation in High Speed mode at 3.4 MHz requires a minimum interface supply voltage of 1.8 V and a mode change in order to enable spike suppression and slope control characteristics compatible with the I²C-bus specification. The high speed mode can be enabled on a transfer-by-transfer basis by sending the master code (0000 1XXX) at the beginning of the transfer. The DA9063L does not make use of clock stretching and delivers read data without additional delay up to 3.4 MHz.

Communication on the 2-wire bus always takes place between two devices, one acting as the master and the other as the slave. The DA9063L only operates as a slave. The 2-wire interface has direct access to two pages of the DA9063L register map (up to 256 addresses). The register at address zero on each page is used as a page control register (with the 2-wire bus ignoring the LSB of control REG_PAGE). Writing to the page control register changes the active page for all subsequent read/write operations unless an automatic return to page 0 was selected by asserting control REVERT. Unless REVERT was asserted after modifying the active page, a read-back of the page

System PMIC for Mobile and Automotive Applications

control register is recommended to ensure that future data exchange is accessing the intended registers.

The DA9063L offers an alternative method to access register pages 2 and 3. These pages can be accessed directly by incrementing the device address by one (default read address 0xB2; write address 0xB3). This removes the need to write to the page register before access to pages 2 and 3, thus reducing the traffic on the 2-wire bus.

6.8.1.1 Details of the 2-wire Control Bus Protocol

All data is transmitted across the 2-bus in groups of 8 bits. To send a bit, the DATA line is driven at the intended state while the CLK is LOW (a low on DATA indicates a zero bit). Once the DATA has settled, the CLK line is brought high and then low. This pulse on CLK clocks the DATA bit into the receiver's shift register, see [Figure 18](#).

A two byte serial protocol is used containing one byte for address and one byte data. Data and address transfer is MSB transmitted first for both read and write operations. Transmission begins with the START condition from the master while the bus is idle. It is initiated by a high-to-low transition on the DATA line while the CLK is in the high state (a STOP condition is indicated by a low-to-high transition on the DATA line while the CLK is in the high state).

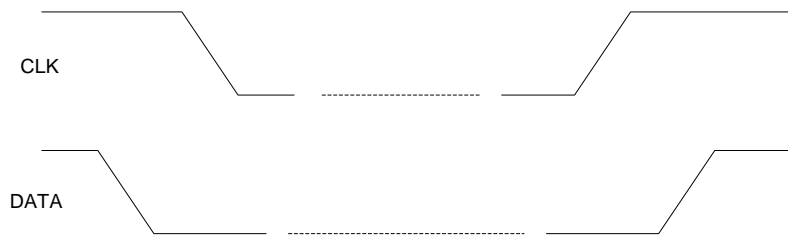

Figure 18: Timing of START and STOP Condition

The 2-WIRE bus is monitored by the DA9063L for a valid slave address when the interface is enabled. It responds immediately when it receives its own slave address. This 'Acknowledge' is done by pulling the DATA line low during the following clock cycle (see the white blocks marked A in [Figure 19](#) to [Figure 23](#)).

The protocol for a register write from master to slave consists of a start condition, a slave address with read/write bit and the 8-bit register address followed by 8 bits of data terminated by a STOP condition (all bytes responded by DA9063L with Acknowledge), as illustrated in [Figure 19](#).

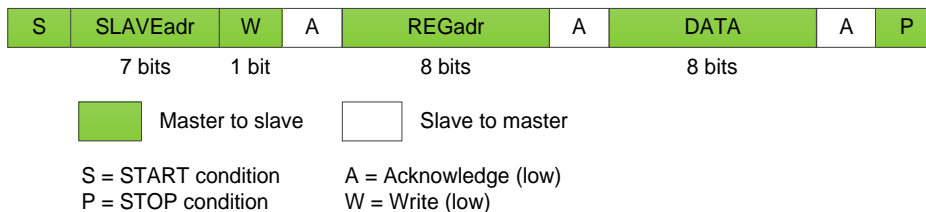

Figure 19: Byte Write (DATA Line)

When the host reads data from a register, it first has to write access the DA9063L with the target register address and then read access the DA9063L with a Repeated START or alternatively a

System PMIC for Mobile and Automotive Applications

second START condition. After receiving the data, the host sends Not Acknowledge and terminates the transmission with a STOP condition (Figure 20).

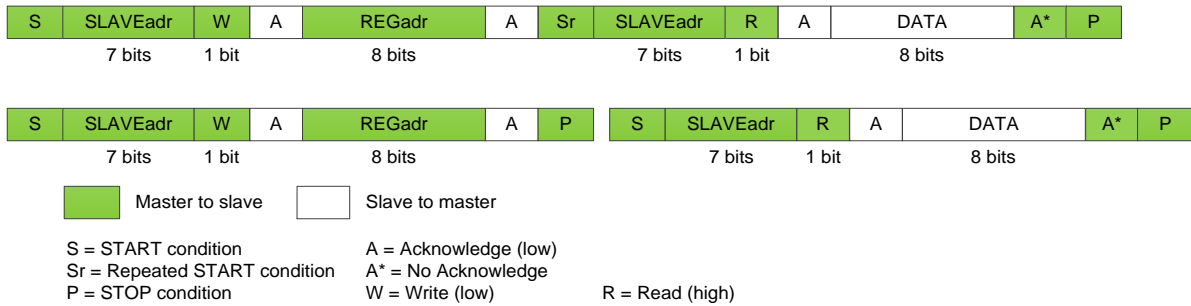

Figure 20: Examples of Byte Read (DATA Line)

Consecutive (page) read mode is initiated from the master by sending an Acknowledge instead of Not Acknowledge after receipt of the data word. The 2-wire control block then increments the address pointer to the next 2-wire address and sends the data to the master. This enables an unlimited read of data bytes until the master sends a Not Acknowledge directly after the receipt of data, followed by a subsequent STOP condition. If a non-existent 2-wire address is read then the DA9063L returns code zero (Figure 21).

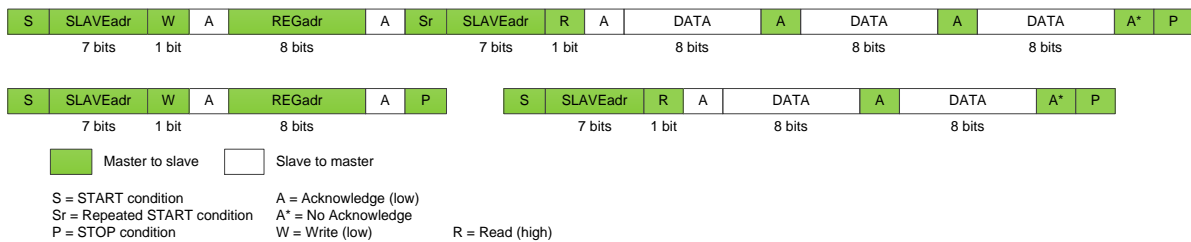

Figure 21: Examples of Page Read (DATA Line)

The slave address after the Repeated START condition must be the same as the previous slave address.

For enhanced data transfer efficiency, the DA9063L supports two write modes: Page Write mode and Repeated Write mode.

Page Write mode is used where the host has multiple bytes of data to be written to consecutive register addresses. It is selected by setting the WRITE MODE control to 0. For Page Write mode the master sends a device address followed by a register address then multiple data bytes. The 2-wire interface automatically increments the register address pointer after each data byte is received. The slave acknowledges each received byte of data until the master sends the STOP condition (Figure 22).

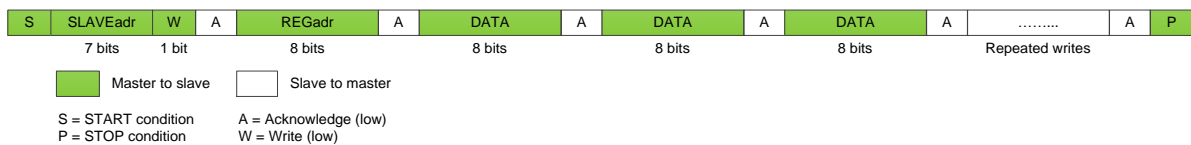

Figure 22: Page Write (DATA Line)

System PMIC for Mobile and Automotive Applications

Repeated Write mode is used where the host has multiple bytes of data to be sent to non-consecutive registers. It is selected by setting the WRITE MODE control to 1. For Repeated Write mode the master sends a device address followed by multiple address-data pairs. The slave acknowledges each received byte until the master sends the STOP condition (Figure 23).

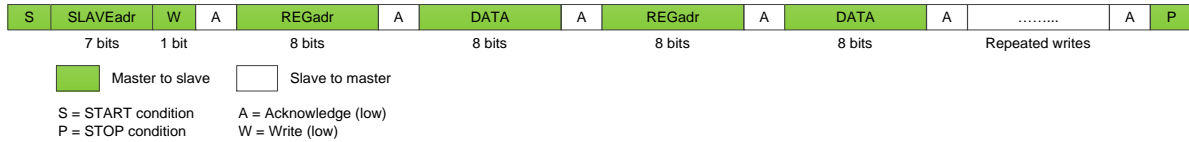

Figure 23: Repeated Write (DATA Line)

System PMIC for Mobile and Automotive Applications

6.9 Voltage Regulators

Three types of low drop-out regulators (LDOs) are integrated on the DA9063L: for sensitive analog rails (for example, RF transceiver supply), the low noise regulators offer high PSRR across a wide frequency range; the LDOs provide an optimized PSRR and noise performance with lowest quiescent current. Quiescent current has been optimized for the always-on type regulators.

The regulators employ Dialog Semiconductor's Smart Mirror™ dynamic biasing that guarantees PSRR to be maintained across the full current range. Quiescent current consumption is dynamically adjusted to the load, which improves efficiency at light load conditions. Furthermore, Dialog Semiconductor's Smart Mirror™ technology allows the capacitor to be placed close to the load.

Note

When placing an LDO capacitor remotely from the DA9063L, the voltage drop (= load current * parasitic PCB impedance) needs to be considered when configuring the LDO output voltage.

Table 33: Regulator Control

| Regulator | Type | V _{OUT} Steps (mV) | Mode | Output Voltage (V) | Supplied Max. Current (mA) | Current Limit LDO/Bypass (mA) | V _{OUT} Control | Notes |
|-----------|-----------|-----------------------------|--------|------------------------|----------------------------|-------------------------------|-----------------------------------|---|
| LDO3 | Standard | 20 | Bypass | 0.9 to 3.44 | 200 | 400/200 | DVC variable slew rate | |
| LDO7 | Standard | 50 | Bypass | 0.9 to 3.6 | 200 | 400/300 | V _{OUT} programmable | |
| LDO8 | Standard | 50 | Bypass | 0.9 to 3.6 | 200 | 400/300 | V _{OUT} programmable | Switching vibration motor driver, common supply with LDO7 |
| LDO9 | Low noise | 50 | | 0.95 to 3.6 | 200 | 400 | V _{OUT} programmable | |
| LDO11 | Standard | 50 | Bypass | 0.9 to 3.6 | 300 | 400/300 | V _{OUT} programmable | |
| LDOCOR E | Always-on | | | 2.5 ±2% accuracy | 4 | | V _{OUT} non-programmable | Internal LDO |

6.9.1 Regulators Controlled by Software

The regulators can be programmed via the power manager interface. All regulators can be enabled or disabled by a write command to the enable bit LDOxx_EN. Each LDO has two voltage registers for output voltage A and B. The appropriate values are stored in the registers VLDOxx_A and VLDOxx_B. The specific output voltage is selected with the bit VLDOxx_SEL. Changes to this control result in immediate output voltage changes on non-DVC regulators and ramped voltage transitions on DVC-enabled regulators. The output voltage can also be changed by directly re-programming the voltage control register. The sequencer also uses these registers and may write to them: their contents can therefore be found to differ from previous write commands.

System PMIC for Mobile and Automotive Applications

For security reasons, the re-programming of registers that may cause damage when being incorrectly programmed (for example, voltage settings) can be disabled with control V_LOCK. This disables write access to registers with an address higher than 0x7F.

6.9.2 Regulators Controlled by Hardware

All regulators can be enabled or disabled under hardware control using GPIO1, 2, or 13. The GPIO port used is defined in register LDOxx_GPI. The output voltages can be switched by the GPIO port between the A and B voltage. The specific GPIO port is defined in register VLDOxx_GPI. After detecting a rising or falling edge at the GPI, the DA9063L configures the related regulators with the status of GPI1, GPI2, or GPI13 (the event bit E_GPI1, E_GPI2, or E_GPI13 is automatically cleared). A parallel write access to the regulator control registers is delayed and later overrides the hardware configuration. The sequencer does not affect regulators controlled via GPIOs.

6.9.3 Power Sequencer Control of LDOs

The power sequencer can control the LDOs. The specific time slot of each LDO is defined with bit LDOx_STEP in register bank starting at address 0x83. The sequencer enables and disables each LDO individually depending on the setting of each LDO's bit LDOx_CONF and LDOx_AUTO. To limit the inrush current, it is recommended to enable a maximum of one regulator (including bucks) per time slot.

If the control OTPREAD_EN is set, the regulator control registers are reloaded from OTP before leaving POWERDOWN mode. During power-up, the sequencer always takes output voltage A (defined in register VLDOxx_A). Therefore, it also clears all VLDOxx_SEL bits.

When powering down, the sequencer disables all LDOs, but the LDOs can be configured to remain on by setting bit LDOxx_CONF. In this case the output voltage B is always selected (value programmed in register VLDOxx_B). The related bit VLDOxx_SEL is set by the sequencer accordingly.

Table 34: LDO Power Sequence Voltage

| LDO Output Voltage During Power-Up Sequencing | | | |
|---|-----------|-----------------|----------------|
| LDOx_CONF | LDOx_AUTO | LDO | Output Voltage |
| - | 1 | gets enabled | A |
| 1 | 0 | gets enabled | A |
| 0 | | disabled | - |
| LDO Output Voltage During Power-Down Sequencing | | | |
| LDOx_CONF | LDOx_AUTO | LDO | Output Voltage |
| 1 | - | remains enabled | B |
| 0 | | gets disabled | - |

The bit DEF_SUPPLY defines the sequencer action for time slot 0. If Bit DEF_SUPPLY is set, all LDOs configured to time slot 0 are enabled or disabled during power-up according to [Table 34](#). If bit DEF_SUPPLY is not set, the LDOs configured to time slot 0 are disabled.

| Note |
|--|
| When control bit LDOxx_SL_B is asserted, the LDO enters a forced sleep mode with the lowest quiescent current, but with a reduced maximum output current. The maximum current is reduced because a smaller |

System PMIC for Mobile and Automotive Applications

output driver is used (a partial pass device). Asserting LDOxx_SL_A results in the same forced sleep mode for an LDO when using the type A voltage register. Before wakeup from POWERDOWN mode (processing time slots from domain SYSTEM), the sequencer can configure all regulators with default voltage values from OTP: this allows any previously altered VLDOxx_A and LDOxx_SL_A settings to be reset.

Entering RESET mode automatically disables all regulators.

6.9.4 Dynamic Voltage Control

LDO3 includes DVC:

- The output voltage can be programmed in 20 mV steps.
- If the feedback signal GP_FB1 is configured to be READY (by asserting PM_FB1_PIN), this port is asserted while slewing and asserts E_DVC_RDY after all voltage and buck regulators have completed slewing.

DVC voltage transitions are handled by the following registers:

- Output voltage setting registers VLDO3_A/VLDO3_B.
When writing into a selected voltage control register the output voltage is immediately ramped to the new value. When writing into the non-selected voltage register the ramping is delayed until this register is selected by toggling VLDO3_SEL.
- The voltage selection registers VLDO3_SEL activate a pre-configured transition to the alternate output voltage. These controls have been grouped together in registers DVC_1 and DVC_2 to better enable synchronized ramping of supply voltages.
- The DVC slew rate for all DVC-enabled regulators can be configured as 10 mV per (0.5, 1.0, 2.0, or 4.0) μ s via control SLEW_RATE. Under light load conditions (< 10 mA), the slew rate is less than the programmed value when the output is close to the start and end of the slope. This is especially the case for the fastest slew rate settings. The negative slew rate is load dependent and might be lower than the one mentioned above.

6.9.5 Pull-Down Resistor

All LDOs have a pull-down resistor at the output when they are disabled. The pull-down resistor can be disabled with bit LDOxx_PD_DIS, and is required when LDOs are used in parallel with another supply. Otherwise the output is pulled to GND.

If an over-voltage occurs (LDO3: $V_{OUT} > 109\%$ of nominal V_{OUT} , LDO7 to 9, and 11: $V_{OUT} > 106\%$ of nominal V_{OUT}), the voltage regulators enable an internal load to discharge the output back to its configured voltage. This can be disabled via LDOxx_PD_DIS.

System PMIC for Mobile and Automotive Applications

6.9.6 Bypass Mode and Current Limit

All LDOs feature a current limiting function. For LDOs with a bypass mode (LDO3, 7, 8, and 11), an over-current is indicated with an interrupt. When at least one of these LDOs reaches the current limit for more than 10 ms, an interrupt is raised to the host (during POWERDOWN mode a wakeup sequence is initiated) and the event bit E_LDO_LIM is set. The interrupt IRQ can be suppressed via the mask bit M_LDO_LIM.

If the current limit condition persists for more than 200 ms (indicating a probable short circuit condition), the related LDO is disabled and its LDOx_EN bit is de-asserted. The LDO remains disabled until a new enable occurs (via hardware or software activation). The automatic shutdown of the LDO can be disabled via bit LDO_SD. The host processor can distinguish if the IRQ is related to a temporary over-current or to a permanent shutdown by polling the related bit LDOx_ILIM or checking LDO3_EN, LDO7_EN, LDO8_EN, and LDO11_EN.

If the current limit is hit for more than 10 ms but less than 200 ms, the IRQ is generated but the related LDO is not disabled. If the current limit is hit for more than 200 ms and the involved LDO is shut down, the LDO<x>_EN bit is de-asserted. If the over-current spike has stopped before the host is able to read the xx_LIM bits, the LDO that has been in current limit cannot be evaluated.

Changing from LDO to bypass mode and back triggers a change of the output voltage with some over/undershoot during the transition phase.

The LDO accuracy specification is not applicable if the LDO has been configured for bypass mode.

For LDOs operated in bypass mode it is recommended to configure the voltage in the VLDO<x>_A register to the expected output voltage of the LDO. When using the LDO above the normal operating range, it is recommended to set the VLDO<x>_A to 0x40 for LDO 3 and to 0x20 for LDO 7, 8, and 11.

6.9.7 LDO Supply from Buck Converter

The LDOs can optionally be supplied from a buck output ($V_{DD} < 2.8\text{ V}$). In this mode some specification parameters change:

- at $V_{DD} = 1.8\text{ V}$, the dropout voltage at I_{max} increases by 70 %
- for a supply voltage less than 1.8 V, the LDO dropout voltage is valid only for 1/3 of the standard I_{max} and the current capability decreases with the provided supply voltage.

LDO11 may be supplied from a rail higher than VSYS/CHG_WAKE (for example, the output of a 5 V boost) as long as $V_{DD} < 5.5\text{ V}$.

6.9.8 LDO Sleep Mode for Reduced I_{OUT}

If the required output current is $< 10\%$ of I_{MAX} , the quiescent power can be reduced by setting an LDO into sleep mode. In this mode, the output driver current capability is reduced to 10 % of I_{MAX} . Sleep mode can be set independently for the output voltage A and B by setting bit LDOxx_SL_A or bit LDOxx_SL_B. During LDO sleep mode, the over-current limit of the LDOs with a bypass function (LDO3, 7, 8, and 11) is reduced to 50 %. As a benefit of Dialog Semiconductor's Smart Mirror™ technology, sleep mode is typically not required because the quiescent current taken by the regulator is automatically minimized when operating at low current demands.

System PMIC for Mobile and Automotive Applications

6.9.9 Vibration Motor Driver

LDO8 provides a third mode dedicated to drive vibration motors selected via bit LDO8_MODE. In this mode, the voltage regulation circuitry is disabled and no external stabilization capacitor is needed. In comparison to LDO mode, the PWM control is more efficient and allows an instant on and off for the vibrator signal.

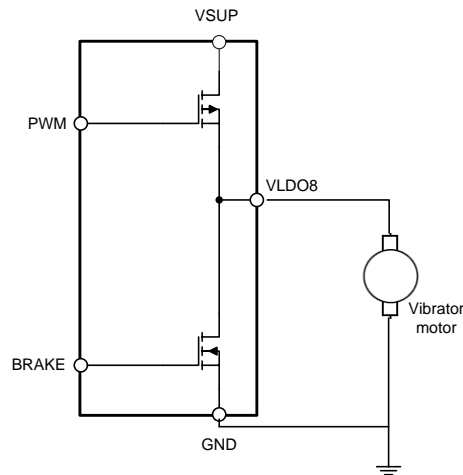

Figure 24: Vibration Motor Driver

The vibrator motor driver is a half-bridge PWM-controlled motor driver, with an automatic battery supply correction of the PWM duty cycle (Figure 24). The PWM base frequency can be selected by PWM_CLK to be either 1.0 MHz or 2.0 MHz (resulting in a PWM repetition rate of 15.6 kHz or 31.25 kHz). The vibration motor speed is determined by the effective output voltage which is set via control VIB_SET (6 bits giving 64 programmable speeds). Setting the output voltage to 0 turns on a braking NMOS transistor to stop the vibration motor immediately.

The motor can also be stopped and started by a level on port nVIB_BRAKE, if enabled via bit PM_FB3_PIN.

The PWM duty cycle is corrected automatically before it is enabled and after each breaking period. It is also automatically corrected every 10 s when it is running for longer periods. These corrections are done via autonomous V_{SYS} measurement via the internal GPADC (overrides control setting of AUTO_VSYS_EN). The duty cycle, D , is given by $D = VIB_SET / V_{SYS}$.

Note

The half-bridge driver transistors have an internal current limit of approximately 400 mA

6.9.10 Core Regulator LDOCORE

The LDOCORE is a 2.5 V supply dedicated for the internal logic of DA9063L. It is used for running the state machine, GPIO pins with comparators, bias, reference, GPADC, OTP, and power manager registers. It is supplied from internal rail V_{DDREF} , powered from either CHG_WAKE or V_{SYS} . When LDOCORE is supplied in RESET mode, its output voltage is temporarily reduced to 2.2 V. In general, LDOCORE is an always-on supply (remaining enabled during RESET mode), but for lowest dissipation power LDOCORE can also be disabled when progressing towards DELIVERY mode.

System PMIC for Mobile and Automotive Applications

6.10 DC/DC Buck Converters

DA9063L includes six DC/DC buck converters with DVC.

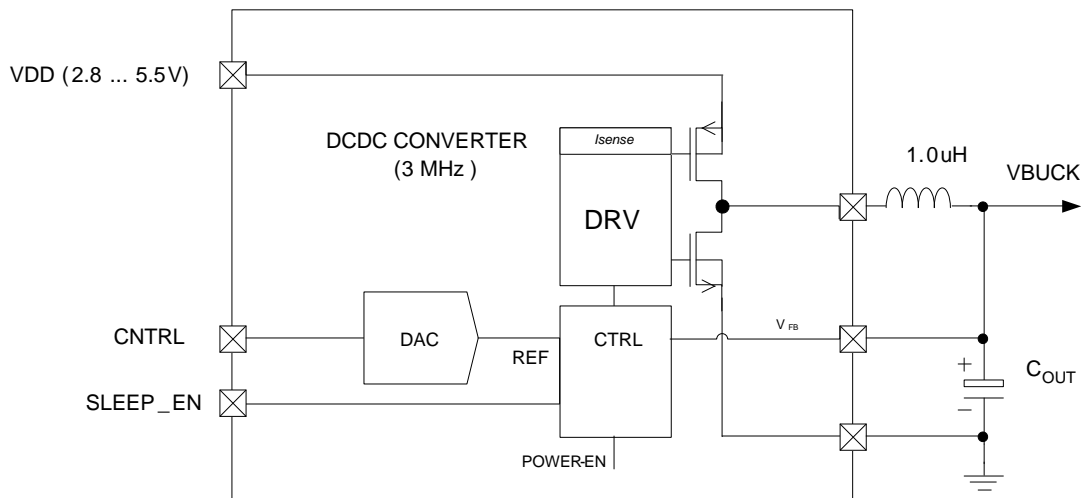

Figure 25: DC-DC Buck Converter

The converters are high efficiency synchronous step-down regulators, operating at a high frequency (3 MHz), supplying individual output voltages with $\pm 3\%$ accuracy. The default output voltage is loaded from OTP and can be set in 10 mV steps. To limit in-rush current from V_{SYS} , the buck converters perform a soft-start for up to 3 ms, when enabled via control `SOFT_START`. During this 3 ms period, the output current of the buck is limited.

The DVC controller allows the following features:

- The buck converter output voltage is programmable over the power manager bus in 10 mV steps.
- If the feedback port `GP_FB1` is configured as `READY`, this port is asserted while slewing and asserts `E_DVC_RDY` after all voltage and buck regulators have stopped slewing.
- Output voltages below 0.7 V are only supported in Pulse Frequency Modulation (PFM) mode. During a voltage reduction below 0.7 V, the slew rate control ends at 0.7 V and the buck mode is automatically changed to PFM mode.

The DVC control is handled by the following registers:

- Output voltage setting register `VBxxxx_A/VBxxxx_B`.
When writing to the voltage control register that is in use by an enabled buck, the output immediately ramps to the new setting. When writing to the voltage control register that is not in use, the ramping is delayed until this register is selected by toggling `VBxxxx_SEL`.
- The voltage register selection `VBxxxx_SEL`.
This activates a pre-configured transition to the alternate output voltage. These controls are grouped into registers `DVC_1` and `DVC_2` to better enable synchronized ramping of supply voltages.
- The DVC slew rate is programmable as at 10 mV per (4, 2, 1, or 0.5) μs via control `SLEW_RATE`. During PFM mode, the negative slew rate is load-dependent and might be lower than the programmed rate.

System PMIC for Mobile and Automotive Applications

The supply current during PWM (synchronous) operation is in the order of 3.5 mA (quiescent current and charge/discharge current) and drops to <math><1 \mu\text{A}</math> in shutdown. Switching frequency is chosen to be high enough (3 MHz) to allow the use of a small 1.0 μH inductor.

The operating mode of the buck converter is selected via the buck control register bits Bx_MODE. The buck converter can be forced to operate in either PWM or PFM mode. Additionally, the buck converter has an automatic mode where it switches between PWM and PFM modes depending on the load current.

The switching converters can be enabled/disabled/configured via the power manager and HS 2-WIRE interface. Writing to Bxxxx_EN/VBxxxx_SEL unconditionally configures the regulator to the selected mode (enabled/disabled). Reading Bxxxx_EN/VBxxxx_SEL provides the actual state, which may differ from a previous write (in the case where the regulator state is changed from GPIO or power sequencer control). All bucks can be controlled with an ID from the power sequencer. If enabled in DEF_SUPPLY, supplies can be configured to default settings when the sequencer passes slot 0.

To limit the inrush current, it is recommended to select individual regulators (including LDOs) only with xxxx_DEF settings.

When powering up, the power sequencer clears VBxxxx_SEL for a buck when it has an ID pointing to the time slot being processed. This forces the regulator to ramp the output voltage to the value programmed inside the related register VBxxxx_A.

When powering down (for example, to POWERDOWN mode), sequencer-controlled supplies are usually disabled but can be configured to remain on by setting Bxxxx_CONF. In the latter case, the sequencer sets VBxxxx_SEL so that the regulator output voltage is ramped to the value programmed inside the related register VBxxxx_B. Disabled bucks can switch off their pull-down resistor. Before wakeup from POWERDOWN mode (processing time slots from domain SYSTEM), the sequencer can configure the bucks with default voltage values from OTP and reset any changed VBxxxx_A settings.

All buck converters provide an optional hardware enable/disable via GPIO1, 2, and 13. A regulator that has to be enabled/disabled from a GPI port selects this feature via its control Bxxxx_GPI. A change of the output voltage from the state of a GPI is enabled via control VBxxxx_GPI. After detecting a rising or falling edge at the GPI, the DA9063L configures the enabled regulators with the status of GPI1, GPI2, or GPI13 (the event bit E_GPI1, E_GPI2 or E_GPI13 is automatically cleared). A parallel write access to the regulator control registers is delayed and later overrides the HW configuration. The sequencer does not change regulator settings enabled for GPI control. Powering down to RESET mode automatically disables all buck converters. When the output of a buck converter is combined with a parallel low power LDO, its pull-down resistor needs to be disabled via Bxxxx_PD_DIS. Otherwise its output is discharged to GND when being disabled.

To allow DVC transitions under load, the buck current limit should be configured at least 40% higher than the required maximum continuous output current. See [Table 35](#) as a guide to determining this limit.

Table 35: Selection of Buck Current Limit from Coil Parameters

| Min. ISAT (mA) | Frequency (MHz) | Buck Current Limit (mA) | Max. Output Current (mA) |
|----------------|-----------------|-------------------------|--------------------------|
| 3800 | 3 | 3400 | 2400 |
| 3100 | 3 | 2800 | 2000 |
| 2400 | 3 | 2100 | 1500 |

System PMIC for Mobile and Automotive Applications

| Min. ISAT (mA) | Frequency (MHz) | Buck Current Limit (mA) | Max. Output Current (mA) |
|----------------|-----------------|-------------------------|--------------------------|
| 1700 | 3 | 1700 | 1200 |

To ensure correct regulation, the buck converters require the supply voltage to be 0.7 V higher than the output voltage. As this is not always possible at higher output voltage settings, the converters BUCKMEM, BUCKIO, and BUCKPERI provide a follower mode where the electrical characteristics of the DC-DC converter no longer apply, but instead the PMOS output driver is fully-on and the output voltage simply follows the dropping input voltage. There will be a voltage drop between the buck VDD supply and the output which results from the on-resistance of the buck PMOS driver and the coil, with the voltage drop magnitude being depending on load current. Bucks running in follower mode will temporarily stop switching and by that process will generate PWM mode 3 MHz sub-harmonics.

6.10.1 BUCKCORE1, BUCKCORE2, and BUCKPRO

BUCKCORE1, BUCKCORE2, and BUCKPRO include a full-current (previously overdrive) mode, individually enabled via control BCORE1_OD, BCORE2_OD, and BPRO_OD.

In full-current mode:

- The maximum current capability is 2500 mA
- The selected current limits are automatically doubled
- The quiescent current increases due to the increased switching losses

For full-current mode, the application requires two 47 μ F output capacitors and an appropriate inductor that can sustain higher currents without heating up or suffering from inductance degradation.

BUCKCORE1 and 2 can also be merged as a dual-phase BUCKCORE with up to 5000 mA maximum output current. If enabled in OTP via BCORE_MERGE, the register controls of BUCKCORE2 (except BCORE2_PD_DIS) are automatically disabled and the output from both coils must be routed together. The feedback signal for both phases is taken from the sense node switch matrix of BUCKCORE1 (the VBUCKCORE2 pin may be left floating if the internal pull-down resistor is enabled by setting BCORE2_PD_DIS = 0). With BCORE1_FB programmed in OTP to 0b000, a differential remote sensing at the point-of-load can be enabled, using VBUCKCORE2 as a GND sense port. In this mode, the BUCKCORE output capacitor voltage has to be routed to port CORE_SWS or GP_FB_2 (selected via control MERGE_SENSE). Depending on the settings of BCORE1_OD, the dual-phase buck provides a maximum 2500 mA or 5000 mA, requiring two or four 47 μ F output capacitors, respectively.

BUCKCORE2 always runs on the inverted clock (anti-phase) of BUCKCORE1. The switching node output of both phases must be connected symmetrically on the PCB (with matched routing inductances and resistances).

System PMIC for Mobile and Automotive Applications

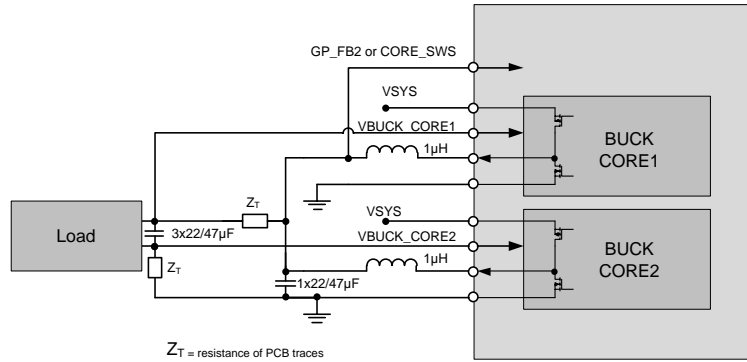

Figure 26: BUCKCORE1 and BUCKCORE2 in Dual-Phase Remote Sense Mode

6.10.2 BUCKPRO in DDR Memory Bus Termination Mode

If enabled via BPRO_VTT_EN, BUCKPRO offers an alternative mode to provide VTT bus termination for DDR memory. In this mode, its output voltage tracks 50 % of the VDDQ sense port voltage (Figure 27). In this mode, BUCKPRO must be set to sync mode either by the host or by OTP configuration. If enabled via BPRO_VTTR_EN, a second VTTR output provides the same voltage for a DDR VTTR reference rail, buffered with ± 10 mA source/sink capability (requires 0.1 µF stabilization capacitor). With BPRO_VTTR_EN being asserted in combination with BPRO_VTT_EN released, the DA9063L provides a VTTR reference buffer with BUCKPRO running in a normal output voltage control mode. If memory termination is not required (BPRO_VTTR_EN = 0), port VDDQ provides the state of event E_GPI2 and port VTTR provides the state of the 1.2 V comparator.

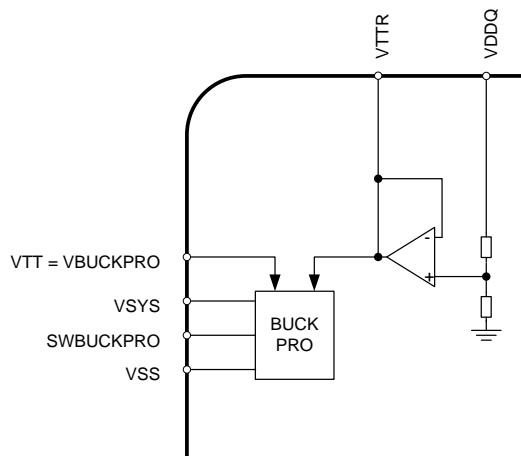

Figure 27: BUCKPRO Memory Bus Termination Mode

System PMIC for Mobile and Automotive Applications

6.10.3 BUCKMEM and BUCKIO in Merged Mode

The converter BUCKMEM can be merged with BUCKIO via control BUCK_MERGE to form a single DC-DC converter with a maximum output current of 3000 mA (Figure 28). The routing of the switcher output pins to the common inductor must be symmetrical. The VBUCKIO feedback pin may be left floating in merged mode if its internal pull-down resistor is enabled by setting BIO_PD_DIS = 0. The inductor (1.0 μ H) and the output capacitor have to be selected according to the increased output current configuration controls of BUCKIO are disabled by asserting the bit BUCK_MERGE; the selected current limits of BUCKMEM are automatically doubled.

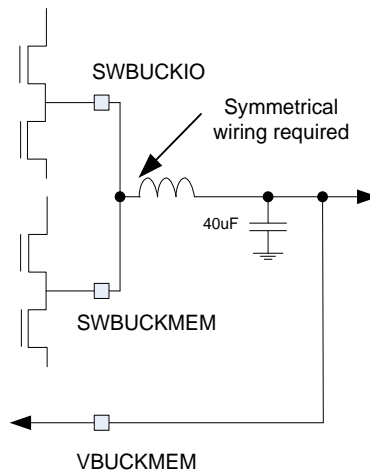

Figure 28: BUCKMEM Merged With BUCKIO

System PMIC for Mobile and Automotive Applications

6.11 General Purpose ADC

6.11.1 ADC Overview

The Analog to Digital Converter (ADC) uses a sample and hold successive approximation switched capacitor architecture. It is supplied from VDDCORE (2.5 V). Configured via control ADC_MODE, it can be used either in high-speed mode with measurement sequences repeated every 1 ms or in economy mode with sequences repeated every 10 ms.

6.11.2 ADC Input MUX

The DA9063L provides an ADC with 10-bit resolution and track and hold circuitry combined with an analog input multiplexer (Figure 29). The analog input multiplexer allows conversion of up to nine different inputs. The track and hold circuit ensures stable input voltages at the input of the ADC during the conversion.

The ADC is used to measure the following inputs:

- Channel 0: V_{SYS}_RES – measurement of the system VDD (2.5 V to 5.5 V)
- Channel 1: ADCIN1_RES – high impedance input (0 to 2.5 V)
- Channel 2: ADCIN2_RES – high impedance input (0 to 2.5 V)
- Channel 3: ADCIN3_RES – high impedance input (0 to 2.5 V)
- Channel 4: T_J – measurement of internal temperature sensor
- Channel 5: Reserved
- Channel 8: MON_A8_RES – group 1 internal regulators voltage (0 to 5.0 V)
- Channel 9: MON_A9_RES – group 2 internal regulators voltage (0 to 5.0 V)
- Channel 10: MON_A10_RES – group 3 internal regulators voltage (0 to 5.0 V)

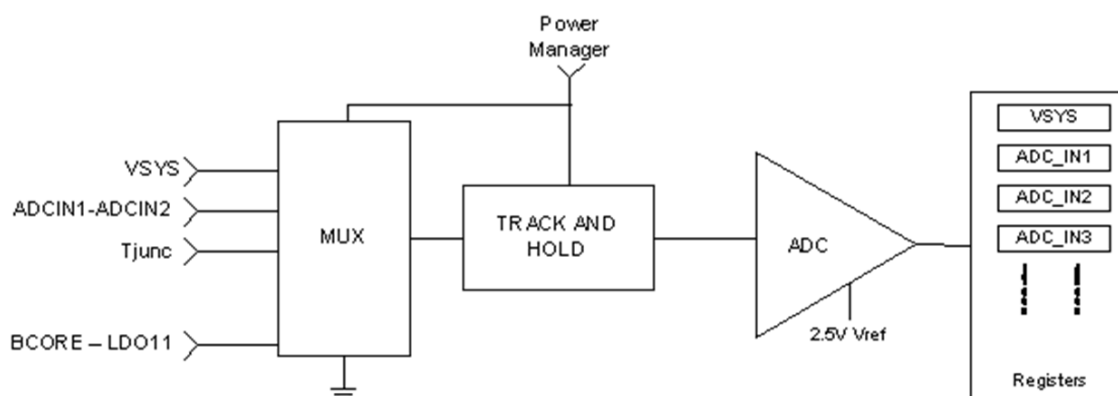

Figure 29: ADC Block Diagram

The MUX selects from and isolates the nine inputs, and presents the channel to be measured to the ADC input. When selected, an input amplifier on the V_{SYS} channel subtracts the VDDCORE reference voltage and scales the signal to the correct value for the ADC.

System PMIC for Mobile and Automotive Applications

6.11.3 Manual Conversion Mode

Manual measurements by the ADC are initiated by an ADC_MAN bit register write. The ADC powers up, one conversion is done on the channel specified by ADC_MUX and the 10-bit result is stored in the ADC_RES_H and ADC_RES_L registers. After the conversion is completed, the ADC powers down again, ADC_MAN bit is reset and an IRQ event flag is set (E_ADC_RDY). The generation of this IRQ can be masked by the IRQ mask M_ADC_RDY.

6.11.4 Automatic Measurements Scheduler

The automatic measurement scheduler allows monitoring of the system voltage V_{SYS} , the auxiliary channels ADCIN1 to 3 and the output voltage supervision of embedded regulators. The results are automatically compared with upper and lower thresholds set by power manager registers to give an nIRQ event if a measurement is outside these levels. All measurements are handled by the scheduler system detailed below.

The scheduler performs a sequence of 10 slots continually repeated according to the configured mode. A slot requires 100 μ s. The pattern of measurements over the 10 slots depends upon the enabled automatic measurements. Additional manual measurement opportunities are available in slots where automatic measurements have been disabled by control bits in ADC_CONT. Automatic measurements only store the eight MSBs of the ADC measurement.

Figure 30 shows (with typical configurations) how the different measurements are scheduled.

Example sequence of AUTO-ADC measurements

| | | | | | | | | | | |
|----------------------|----|----|---|----|----|---|----|-----|---|----|
| Slot No _q | 0 | 1 | 2 | 3 | 4 | 5 | 6 | 7 | 8 | 9 |
| | A0 | A8 | M | A1 | A9 | M | A2 | A10 | M | A3 |

Each Slot allows 1 automatic or manual measurement to be made

A0 - Automatic measurement of V_{SYS} (mux channel 0)

A1 - Automatic measurement of ADCIN1 (mux channel 1)

A2 - Automatic measurement of ADCIN2 (mux channel 2)

A3 - Automatic measurement of ADCIN3 (mux channel 3)

A8 - Automatic measurement of multiplexed regulator output voltages (mux channel 8)

A9 - Automatic measurement of multiplexed regulator output voltages (mux channel 9)

A10 - Automatic measurement of multiplexed regulator output voltages (mux channel 10)

M indicates time slots when a Manual measurement can be made

Figure 30: ADC Sequence

System PMIC for Mobile and Automotive Applications

6.11.4.1 A0: V_{SYS} Voltage nIRQ Measurement Mode

V_{SYS} is measured, stored in $VSYS_RES$ and compared with the $VSYS_MON$ threshold. If the result of the comparison is different to its previous state (being either lower or higher) for three consecutive readings, an E_VDD_MON event is generated. Glitches of a duration less than three consecutive measurements do not update the state; events are triggered at rising and falling edges of the state signal. This multiple reading debounces the V_{SYS} voltage before issuing an nIRQ. After the nIRQ assertion, the automatic measurement of channel V_{SYS} is paused for reading. The host must clear the associated event flag to re-enable the supervision of V_{SYS} . The event-causing value is kept in the result register.

If selected via $GPIO12_PIN$, the debounced comparator state can be indicated via the $GPO12$ port, representing a power good signal that can be used, for example, to trigger boot activities on external ICs. If no action is taken to restore the V_{SYS} voltage (that is, discharging of the battery continues), the host may consider switching off optional always-on blocks to save energy later on. V_{SYS} measurements are enabled via control $AUTO_VSYS_EN$.

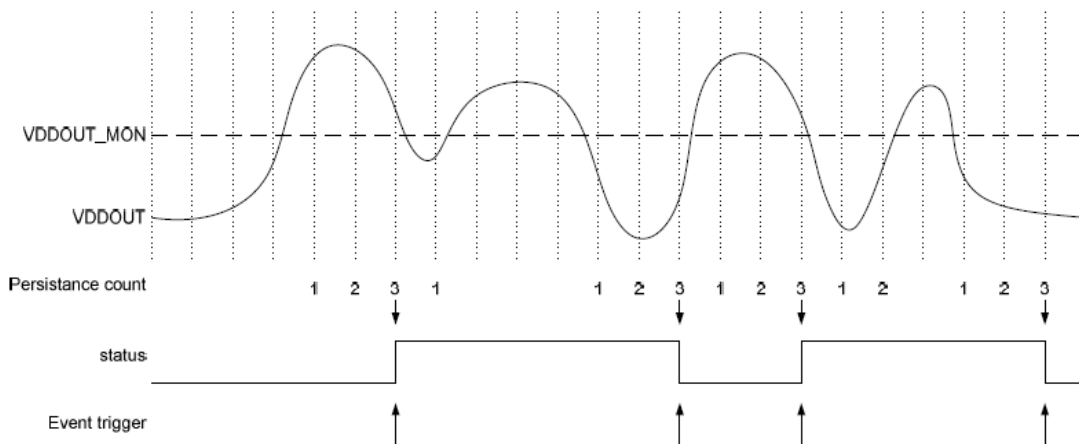

Figure 31: V_{SYS} Monitor Persistence Behavior

System PMIC for Mobile and Automotive Applications

6.11.4.2 A1, A2, A3: Automatic Measurement and High/Low Threshold Warning nIRQ Mode

The automatic measurement result of channel ADC_IN1 is stored in the ADCIN1_RES register. If a reading of A1 is less than AUTO1_LOW or greater than AUTO1_HIGH, then the event flag E_GPI0 is set. If nIRQ is asserted, the automatic measurement of channel ADC_IN1 is paused until the host has cleared the associated event flag (the event-causing value is kept in the result register). The assertion of nIRQ can be masked by IRQ mask M_GPI0, which also disables the pausing of automatic measurements. If debouncing is selected via ADCIN1_DEB the event is only asserted if two consecutive measurements override the same threshold. The automatic measurement is enabled by register AUTO_AD1_EN. In addition, it is possible to use ADCIN_1 with a 1 μ A to 40 μ A current source that allows automatic measurement of a resistor value (programmed via ADCIN1_CUR). The current source is enabled by AD1_ISRC_EN. During automatic measurements the enabled current source is dynamically switched off at the end of the conversion and switched on one slot prior to the next ADCIN_1 measurement (to enable minimum current consumption, and allow any external capacitance voltage to settle); otherwise its status is static.

A similar functionality is available at ADC_IN2 and ADC_IN3. ADC_IN2 provides notification to the processor via a fixed voltage comparator (also available when ADC is powered down) but the ADCIN2 current source is static (no dynamic switch-off at the end of automatic conversion). The input selection switch of ADC_IN2 provides an enhanced isolation (80 dB typ.) between the externally-connected circuit and the internal ADC block (for example, allowing the DC supervision of noise sensitive audio lines).

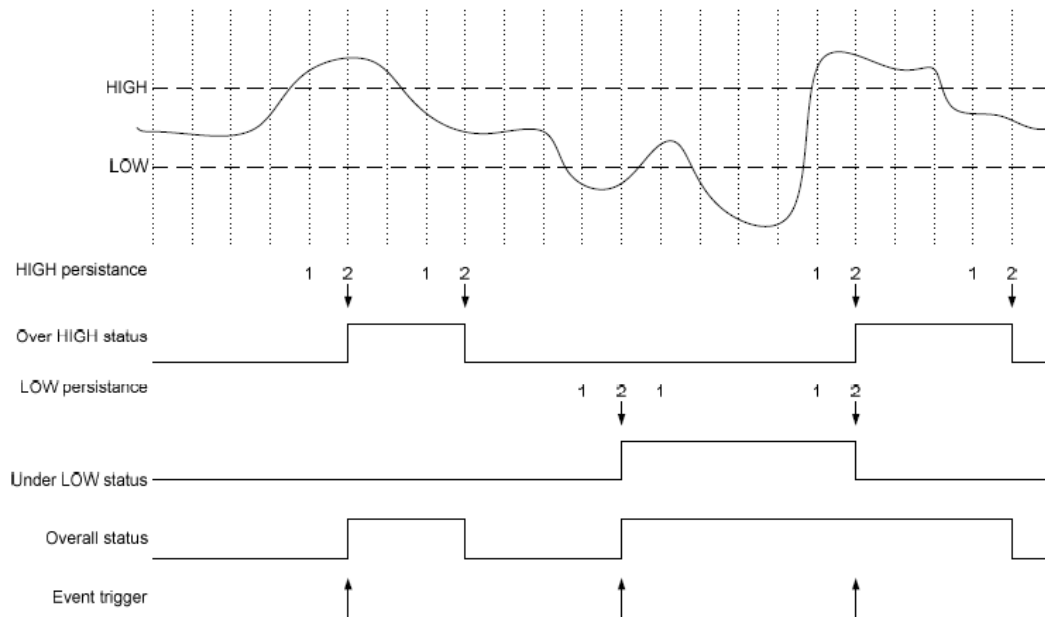

Figure 32: A1, A2, A3 Persistence Behavior

System PMIC for Mobile and Automotive Applications

6.11.4.3 A8, A9, A10: Automatic Regulator Monitor with Under- or Over-Voltage Shutdown

DA9063L provides the capability to monitor the output voltage of internal regulators. In case of a catastrophic failure, the related regulator is disabled. This feature is enabled using control MON_MODE. Each internal regulator is assigned to a GPADC input channel and can be individually enabled for monitoring via controls BCORE1_MON_EN to LDO11_MON_EN. For example, if ADC channel A8 is connected to an enabled regulator and it is also enabled for monitoring, the ADC automatically measures the regulator output voltage every 1 ms (10 ms in ADC economy mode). Simultaneously, two relative thresholds are calculated from the regulator nominal output voltage (supporting DVC). If the regulator is out of range, the voltage measurement is stored inside MON_A8_RES, the regulator ID is recorded inside the index MON_A8_IDX and the event flag E_REG_UVOV is set. To secure a stable output voltage, the monitoring is delayed after regulators are switched on and when changing their voltage level to a new target (that is, during DVC slewing, after writing into the active regulator voltage register, or when the active voltage control register is changing between Vxxx_A and Vxxx_B). This delay is programmable using control UVOV_DELAY.

If debouncing is selected via MON_DEB, an event is only created if two consecutive measurements exceed the same threshold. The feature is also available for channels A9 and A10.

Table 36: Assignment of Regulators for Voltage Monitoring

| ADC Channel | Regulator | Enable |
|-------------|--|--|
| A8 | BUCKCORE1 BUCKCORE2 BUCKPRO LDO3 LDO11 | BCORE1_MON_EN BCORE2_MON_EN BPRO_MON_EN LDO3_MON_EN LDO11_MON_EN |
| A9 | BUCKIO BUCKMEM BUCKPERI | BIO_MON_EN BMEM_MON_EN BPERI_MON_EN |
| A10 | LDO7 LDO8 LDO9 | LDO7_MON_EN LDO8_MON_EN LDO9_MON_EN |

If more than one regulator is assigned to A8, A9, or A10, the regulator measurements are sequentially multiplexed on this channel (elongates the measurement period of 1 ms or 10 ms by each additional assigned regulator). In the case of an E_REG_UVOV event, the regulator monitoring continues and shuts down rails facing catastrophic failure (voltage and IDX controls contain information for determining the cause of the most recently detected under- or over-voltage). When clearing E_REG_UVOV via a host write, the related regulator index controls are reset. In the unlikely case in which several regulators from a sequenced ADC channel have triggered an under- or over-voltage condition before the host was able to read the related controls, all monitored supplies may be checked for their actual state (enabled or shutdown) to detect if further supplies have also been shut down in addition to the one captured by the index control.

The assertion of nIRQ can be masked by IRQ mask M_REG_UVOV. With a masked nIRQ from regulator supervision, the setting of MON_RES determines whether an out-of-range detection disables the related regulator or triggers the assertion of port nRESET. In the latter case, nRESET is asserted for 1 ms and continues to be asserted until the regulator returns to being in range (regulators that are not enabled but are selected for monitoring do not trigger the assertion of nRESET). With a masked nIRQ, GP_FB2 can be configured to flag PWR_OK, indicating that all monitored regulator voltages are in-range. Selecting disabled regulators for monitoring suppresses the assertion of PWR_OK.

System PMIC for Mobile and Automotive Applications

The regulator monitor unit provides alternative modes selected via MON_MODE. In measurement-only mode, the event flag E_REG_UVOV is set for every automatic measurement result being available on either A8, A9, or A10 (with a maximum of one regulator per channel being enabled for measurements). When enabled, an auto-measurement on A8, A9, or A10 allows the host to get its actual output voltage from registers MON_A8_RES to MON_A10_RES. When multiple ADC channels are enabled for automatic regulator voltage measurements, the burst measurement mode may reduce the control interface traffic and number of nIRQ assertions. When the ADC time slot of A10 has finished, the event flag E_REG_UVOV is set (independent of A10 being enabled for auto-measurements). The host can then read the measurement results stored inside MON_A8_RES - MON_A10_RES as a block. During measurement modes, there are no threshold comparisons or regulator shutdowns. If the nIRQ line was asserted, automatic measurements on channels A8 (A9 and A10) are paused until the host has cleared the associated event flag (the event-causing value is kept in the result registers). During measurement modes, E_REG_UVOV is cleared by writing the read value into register EVENT_B. To sequentially measure other regulators on ADC input channels A8, A9, and A10, the host has to set the monitor enable for the next measurement slot to the required regulator before clearing the event. The assertion of nIRQ can be masked by IRQ mask M_REG_UVOV, which also disables the pausing of automatic measurements. For further information about voltage monitoring, please see DA9063 Voltage Monitoring [2].

Note

Voltage monitoring function cannot be used for any LDO in bypass mode.

6.11.4.4 A4: Manual Measurement T_J

The 10-bit result of manual measurements is stored in the registers ADC_RES_L and ADC_RES_H. Channel 4 (T_J) is used to measure the output of the internal temperature sensor (generated from a proportional to absolute temperature (PTAT) current using a bandgap reference circuit). The ADC measurement result and the T_OFFSET value can be used by the host to calculate the internal junction temperature, defined by the following formula:

$$T_J [^{\circ}\text{C}] = -0.398 * (\text{ADC} - T_OFFSET) + 330$$

Manual measurements on A8 to A10 are possible, but require disabling the automatic measurements on these channels and also ensuring that only one regulator is connected to each of these ADC channels.

NOTE

The T_OFFSET value is stored in the T_OFFSET register at address 0x104 during manufacture.

6.11.5 Fixed Threshold Comparator

A comparator with a threshold of 1.2 V is connected to the input of ADC channel 2. The comparator is asserted when the input voltage exceeds or drops below 1.2 V for at least 10 ms (debouncing). After being enabled via COMP1V2_EN, the status flag COMP1V2 indicates the actual state and a maskable interrupt request E_COMP1V2 is generated at the falling and rising edge state transitions. The comparator may be disabled via COMP1V2_EN when auto-measurements with high resolution are executed on ADCIN2.

System PMIC for Mobile and Automotive Applications

6.12 Adjustable Frequency Internal Oscillator

An internal oscillator provides a nominal 6.0 MHz clock that is divided down to 3.0 MHz for the buck converters. It is divided down to 2.0 MHz to control the digital core, timers, PWM units, charge pump and ADC. The frequency of the internal oscillator is adjusted during the initial start-up sequence of the DA9063L to within 5 % of the nominal 6.0 MHz. It can be adjusted further within ± 10 % via register control OSC_FRQ. The tolerance of this frequency affects most absolute timer values and PWM repetition rates (for example, LED and vibrator mode drivers) of the DA9063L.

6.13 Reference Voltage Generation: VREF, VLNREF

The DA9063L includes a temperature-independent voltage reference circuit which is derived from an internal band-gap reference and OTP-trimmed buffer amplifier. The output voltage on VREF is trimmed to 1.2 V and the reference is decoupled by an external capacitor on the VREF pin. A lower voltage instance of VREF is provided at VLNREF (0.9 V) and used for the LDOs. These pins must not be loaded. The IREF pin provides the internally used accurate current bias and requires an external 200 k Ω precision resistor.

6.14 Thermal Supervision

The application must ensure that the DA9063L junction temperature does not exceed 125 °C. To protect the DA9063L from damage due to excessive power dissipation, the internal temperature is continuously monitored. Whenever the junction temperature is higher than TEMP_WARN = 125 °C, an E_TEMP event is asserted and an IRQ is generated for the host. If this occurs during POWERDOWN mode, a wakeup is triggered.

The host may then check the exact junction temperature by a manual measurement on GPADC channel 4. An 8-bit OTP register (T_OFFSET) can be used to store its offset at a known temperature (for example 50 °C) to improve the absolute accuracy, which should then be ± 7 °C of the measured silicon die junction temperature. This T_OFFSET can be used by the host to calculate the absolute die temperature.

The absolute die junction temperature can be calculated by the host using the result from the ADC channel 4 measurement result and the T_OFFSET trim values.

When the junction temperature exceeds 125 °C, it is recommended to shut down optional functions of the application allowing the DA9063L to cool. When the junction temperature increases further, exceeding TEMP_CRIT = 140 °C, the fault flag TEMP_CRIT is asserted in the FAULT_LOG register and the DA9063L immediately shuts down to RESET mode. The fault condition remains as long as the junction temperature is higher than TEMP_WARN. The TEMP_CRIT flag can be evaluated by the application after the next power up. Whenever the junction temperature exceeds TEMP_POR = 150 °C, a POR to the digital core is immediately asserted and this stops all functions of the DA9063L. This is necessary to prevent the possibility of permanent device damage.

6.15 Main System Rail Voltage Supervision

The supervision of the system supply V_{SYS} is performed by two comparators. One monitors the under-voltage level VDD_FAULT_LOWER (fault condition indicator); the other, VDD_FAULT_UPPER, indicates a good (valid) battery/external supply. The high-to-low transition of the VDD_FAULT_UPPER signal is also used as a low system supply warning indicator, informing the host via event E_VDD_WARN (or the assertion of port nVDDFAULT) that the system rail may soon drop below the under-voltage threshold.

System PMIC for Mobile and Automotive Applications

The VDD_FAULT_LOWER threshold is OTP-configurable and can be set via the VDD_FAULT_ADJ control bits from 2.5 V to 3.25 V in steps of 50 mV. The VDD_FAULT_UPPER level is also OTP-configurable and can be set via the VDD_HYST_ADJ from 100 to 450 mV higher than the programmed VDD_FAULT_LOWER threshold.

System PMIC for Mobile and Automotive Applications

7 Register Map

This section provides an overview of the registers. A description of each register is provided in 11.

| Hex | Register | 7 | 6 | 5 | 4 | 3 | 2 | 1 | 0 | |
|--|------------|--------------------|-------------|------------|-------------|-----------|--------------------|--------------|-----------|--|
| PAGE 0 | | | | | | | | | | |
| 00 | PAGE_CON | Revert | WRITE_MODE | Reserved | | | REG_PAGE | | | |
| System Control and Event Registers (SYSMON) | | | | | | | | | | |
| 01 | STATUS_A | Reserved | | | | COMP1V2 | DVC_BUSY | WAKE | nONKEY | |
| 02 | STATUS_B | GPI7 | GPI6 | GPI5 | GPI4 | GPI3 | GPI2 | GPI1 | GPI0 | |
| 03 | STATUS_C | GPI15 | GPI14 | GPI13 | GPI12 | GPI11 | GPI10 | GPI9 | GPI8 | |
| 04 | STATUS_D | LDO11_LIM | LDO8_LIM | LDO7_LIM | Reserved | LDO3_LIM | Reserved | | | |
| 05 | FAULT_LOG | WAIT_SHUT | nSHUTDOWN | KEY_RESET | TEMP_CRIT | VDD_START | VDD_FAULT | POR | TWD_ERROR | |
| 06 | EVENT_A | EVENTS_D | EVENTS_C | EVENTS_B | E_SEQ_RDY | E_ADC_RDY | E_TICK | E_ALARM | E_nONKEY | |
| 07 | EVENT_B | E_VDD_WARN | E_VDD_MON | E_DVC_RDY | E_REG_UVOV | E_LDO_LIM | E_COMP_1V2 | E_TEMP | E_WAKE | |
| 08 | EVENT_C | E_GPI7 | E_GPI6 | E_GPI5 | E_GPI4 | E_GPI3 | E_GPI2 | E_GPI1 | E_GPI0 | |
| 09 | EVENT_D | E_GPI15 | E_GPI14 | E_GPI13 | E_GPI12 | E_GPI11 | E_GPI10 | E_GPI9 | E_GPI8 | |
| 0A | IRQ_MASK_A | Reserved | | | M_SEQ_RDY | M_ADC_RDY | M_TICK | M_ALARM | M_nONKEY | |
| 0B | IRQ_MASK_B | M_VDD_WARN | M_VDD_MON | M_DVC_RDY | M_REG_UVOV | M_LDO_LIM | M_COMP_1V2 | M_TEMP | M_WAKE | |
| 0C | IRQ_MASK_C | M_GPI7 | M_GPI6 | M_GPI5 | M_GPI4 | M_GPI3 | M_GPI2 | M_GPI1 | M_GPI0 | |
| 0D | IRQ_MASK_D | M_GPI15 | M_GPI14 | M_GPI13 | M_GPI12 | M_GPI11 | M_GPI10 | M_GPI9 | M_GPI8 | |
| 0E | CONTROL_A | CP_EN | M_POWER1_EN | M_POWER_EN | M_SYSTEM_EN | STANDBY | POWER1_EN | POWER_EN | SYSTEM_EN | |
| 0F | CONTROL_B | BUCK_SLOWS TART | Reserved | | nONKEY_LOCK | nRES_MODE | RESET_BLINKIN G | WATCHDOG_DIS | CHG_SEL | |
| 10 | CONTROL_C | DEF_SUPPLY | SLEW_RATE | | OTPREAD_EN | AUTO_BOOT | DEBOUNCING | | | |

System PMIC for Mobile and Automotive Applications

| Hex | Register | 7 | 6 | 5 | 4 | 3 | 2 | 1 | 0 |
|--|---------------|--------------|--------------|-------------|-------------|-------------|-------------|--------------|-------------|
| 11 | CONTROL_D | BLINK_DUR | | BLINK_FRQ | | | TWDSCALE | | |
| 12 | CONTROL_E | V_LOCK | PM_FB3_PIN | PM_FB2_PIN | PM_FB1_PIN | ECO_MODE | Reserved | RTC_MODE_SD | RTC_MODE_PD |
| 13 | CONTROL_F | Reserved | WAKE_UP | SHUTDOWN | WATCHDOG | | | | |
| 14 | PD_DIS | PMCONT_DIS | OUT32K_PAUSE | BBAT_DIS | Reserved | HS2IF_DIS | PMIF_DIS | GPADC_PAUSE | GPI_DIS |
| GPIO Control Registers (GPIO) | | | | | | | | | |
| 15 | GPIO0-1 | GPIO1_WEN | GPIO1_TYPE | GPIO1_P IN | | GPIO0_WEN | GPIO0_TYPE | GPIO0_P IN | |
| 16 | GPIO2-3 | GPIO3_WEN | GPIO3_TYPE | GPIO3_P IN | | GPIO2_WEN | GPIO2_TYPE | GPIO2_P IN | |
| 17 | GPIO4-5 | GPIO5_WEN | GPIO5_TYPE | GPIO5_P IN | | GPIO4_WEN | GPIO4_TYPE | GPIO4_P IN | |
| 18 | GPIO6-7 | GPIO7_WEN | GPIO7_TYPE | GPIO7_P IN | | GPIO6_WEN | GPIO6_TYPE | GPIO6_P IN | |
| 19 | GPIO8-9 | GPIO9_WEN | GPIO9_TYPE | GPIO9_P IN | | GPIO8_WEN | GPIO8_TYPE | GPIO8_P IN | |
| 1A | GPIO10-11 | GPIO11_WEN | GPIO11_TYPE | GPIO11_P IN | | GPIO10_WEN | GPIO10_TYPE | GPIO10_P IN | |
| 1B | GPIO12-13 | GPIO13_WEN | GPIO13_TYPE | GPIO13_P IN | | GPIO12_WEN | GPIO12_TYPE | GPIO12_P IN | |
| 1C | GPIO14-15 | GPIO15_WEN | GPIO15_TYPE | GPIO15_P IN | | GPIO14_WEN | GPIO14_TYPE | GPIO14_P IN | |
| 1D | GPIO_MODE0-7 | GPIO7_MODE | GPIO6_MODE | GPIO5_MODE | GPIO4_MODE | GPIO3_MODE | GPIO2_MODE | GPIO1_MODE | GPIO0_MODE |
| 1E | GPIO_MODE8-15 | GPIO15_MODE | GPIO14_MODE | GPIO13_MODE | GPIO12_MODE | GPIO11_MODE | GPIO10_MODE | GPIO9_MODE | GPIO8_MODE |
| 1F | SWITCH_CONT | CP_EN_MODE | CORE_SW_INT | SWITCH_SR | | | | CORE_SW_GP I | |
| Regulator Control Registers (REG) | | | | | | | | | |
| 20 | BCORE2_CONT | Reserved | VBCORE2_GPI | Reserved | BCORE2_CONF | BCORE2_GPI | | BCORE2_EN | |
| 21 | BCORE1_CONT | CORE_SW_CONF | VBCORE1_GPI | CORE_SW_EN | BCORE1_CONF | BCORE1_GPI | | BCORE1_EN | |
| 22 | BPRO_CONT | Reserved | VBPRO_GPI | Reserved | BPRO_CONF | BPRO_GPI | | BPRO_EN | |
| 23 | BMEM_CONT | Reserved | VBMEM_GPI | Reserved | BMEM_CONF | BMEM_GPI | | BMEM_EN | |
| 24 | BIO_CONT | Reserved | VBIO_GPI | Reserved | BIO_CONF | BIO_GPI | | BIO_EN | |

System PMIC for Mobile and Automotive Applications

| Hex | Register | 7 | 6 | 5 | 4 | 3 | 2 | 1 | 0 |
|---|------------|--------------|-------------|-------------|-------------|--------------|-------------|-------------|--------------|
| 25 | BPERI_CONT | PERI_SW_CONF | BPERI_GPI | | PERI_SW_EN | BPERI_CONF | PERI_SW_GPI | | BPERI_EN |
| 26 | RESERVED | Reserved | Reserved | | Reserved | Reserved | Reserved | | Reserved |
| 27 | RESERVED | Reserved | Reserved | | Reserved | Reserved | Reserved | | Reserved |
| 28 | LDO3_CONT | LDO3_CONF | VLDO3_GPI | | Reserved | LDO3_PD_DIS | LDO3_GPI | | LDO3_EN |
| 29 | RESERVED | Reserved | Reserved | | Reserved | Reserved | Reserved | | Reserved |
| 2A | RESERVED | Reserved | Reserved | | Reserved | Reserved | Reserved | | Reserved |
| 2B | RESERVED | Reserved | Reserved | | Reserved | Reserved | Reserved | | Reserved |
| 2C | LDO7_CONT | LDO7_CONF | VLDO7_GPI | | VLDO7_SEL | LDO7_PD_DIS | LDO7_GPI | | LDO7_EN |
| 2D | LDO8_CONT | LDO8_CONF | VLDO8_GPI | | VLDO8_SEL | LDO8_PD_DIS | LDO8_GPI | | LDO8_EN |
| 2E | LDO9_CONT | LDO9_CONF | VLDO9_GPI | | VLDO9_SEL | LDO9_PD_DIS | LDO9_GPI | | LDO9_EN |
| 2F | RESERVED | Reserved | Reserved | | Reserved | Reserved | Reserved | | Reserved |
| 30 | LDO11_CONT | LDO11_CONF | VLDO11_GPI | | VLDO11_SEL | LDO11_PD_DIS | LDO11_GPI | | LDO11_EN |
| 31 | VIB | Reserved | | | VIB_SET | | | | |
| 32 | DVC_1 | VLDO3_SEL | VLDO2_SEL | VLDO1_SEL | VBPERI_SEL | VBMEM_SEL | VBPRO_SEL | VBCORE2_SEL | VBCORE1_SEL |
| 33 | DVC_2 | VLDO4_SEL | Reserved | | | | | | VBIO_SEL |
| GP-ADC Control Registers (GPADC) | | | | | | | | | |
| 34 | ADC_MAN | Reserved | Reserved | ADC_MODE | ADC_MAN | ADC_MUX | | | |
| 35 | ADC_CONT | COMP1V2_EN | AD3_ISRC_EN | AD2_ISRC_EN | AD1_ISRC_EN | AUTO_AD3_EN | AUTO_AD2_EN | AUTO_AD1_EN | AUTO_VSYS_EN |
| 36 | VSYS_MON | VSYS_MON | | | | | | | |
| 37 | ADC_RES_L | ADC_RES_LSB | | | Reserved | | | | |
| 38 | ADC_RES_H | ADC_RES_H | | | | | | | |
| 39 | VSYS_RES | VSYS_RES | | | | | | | |

System PMIC for Mobile and Automotive Applications

| Hex | Register | 7 | 6 | 5 | 4 | 3 | 2 | 1 | 0 | |
|-----------------|-------------|-------------|----------|----------|----------|----------|---|----------|---|--|
| 3A | ADCIN1_RES | ADCIN1_RES | | | | | | | | |
| 3B | ADCIN2_RES | ADCIN2_RES | | | | | | | | |
| 3C | ADCIN3_RES | ADCIN3_RES | | | | | | | | |
| 3D | MON_A8_RES | MON_A8_RES | | | | | | | | |
| 3E | MON_A9_RES | MON_A9_RES | | | | | | | | |
| 3F | MON_A10_RES | MON_A10_RES | | | | | | | | |
| Reserved | | | | | | | | | | |
| 40 | RESERVED | Reserved | Reserved | | | | | Reserved | | |
| 41 | RESERVED | Reserved | | Reserved | | | | | | |
| 42 | RESERVED | Reserved | | | Reserved | | | | | |
| 43 | RESERVED | Reserved | | | Reserved | | | | | |
| 44 | RESERVED | Reserved | | | | Reserved | | | | |
| 45 | RESERVED | Reserved | Reserved | Reserved | | | | | | |
| 46 | RESERVED | Reserved | | | Reserved | | | | | |
| 47 | RESERVED | Reserved | | | Reserved | | | | | |
| 48 | RESERVED | Reserved | | | Reserved | | | | | |
| 49 | RESERVED | Reserved | | | Reserved | | | | | |
| 4A | RESERVED | Reserved | | Reserved | Reserved | Reserved | | | | |
| 4B | RESERVED | Reserved | Reserved | Reserved | | | | | | |
| Reserved | | | | | | | | | | |
| 4C | RESERVED | Reserved | | | | | | | | |
| 4D | RESERVED | Reserved | | | | | | | | |
| 4E | RESERVED | Reserved | | | | | | | | |

System PMIC for Mobile and Automotive Applications

| Hex | Register | 7 | 6 | 5 | 4 | 3 | 2 | 1 | 0 |
|-----|----------|----------|---|---|---|---|---|---|---|
| 4F | RESERVED | Reserved | | | | | | | |

System PMIC for Mobile and Automotive Applications

| Hex | Register | 7 | 6 | 5 | 4 | 3 | 2 | 1 | 0 |
|--|-----------|----------------|------------|----------|----------------|---|----------|---|---|
| PAGE 1 | | | | | | | | | |
| 80 | PAGE_CON | Revert | WRITE_MODE | Reserved | | | REG_PAGE | | |
| Sequencer Control Registers (SEQ) | | | | | | | | | |
| 81 | SEQ | NXT_SEQ_START | | | SEQ_POINTER | | | | |
| 82 | SEQ_TIMER | SEQ_DUMM | | | SEQ_TIME | | | | |
| 83 | RESERVED | Reserved | | | Reserved | | | | |
| 84 | ID_4_3 | Reserved | | | LDO3_STEP | | | | |
| 85 | ID_6_5 | Reserved | | | Reserved | | | | |
| 86 | ID_8_7 | LDO8_STEP | | | LDO7_STEP | | | | |
| 87 | ID_10_9 | Reserved | | | LDO9_STEP | | | | |
| 88 | ID_12_11 | PD_DIS_STEP | | | LDO11_STEP | | | | |
| 89 | ID_14_13 | BUCKCORE2_STEP | | | BUCKCORE1_STEP | | | | |
| 8A | ID_16_15 | BUCKIO_STEP | | | BUCKPRO_STEP | | | | |
| 8B | ID_18_17 | BUCKPERI_STEP | | | BUCKMEM_STEP | | | | |
| 8C | RESERVED | Reserved | | | Reserved | | | | |
| 8D | ID_22_21 | GP_FALL1_STEP | | | GP_RISE1_STEP | | | | |
| 8E | ID_24_23 | GP_FALL2_STEP | | | GP_RISE2_STEP | | | | |
| 8F | ID_26_25 | GP_FALL3_STEP | | | GP_RISE3_STEP | | | | |
| 90 | ID_28_27 | GP_FALL4_STEP | | | GP_RISE4_STEP | | | | |
| 91 | ID_30_29 | GP_FALL5_STEP | | | GP_RISE5_STEP | | | | |
| 92 | ID_32_31 | EN32K_STEP | | | WAIT_STEP | | | | |
| 93 | RESERVED | Reserved | | | Reserved | | | | |
| 94 | RESERVED | Reserved | | | Reserved | | | | |

System PMIC for Mobile and Automotive Applications

| Hex | Register | 7 | 6 | 5 | 4 | 3 | 2 | 1 | 0 |
|--|-------------|-------------|-----------|---------------|-------------|--------------|-----------|---|---|
| 95 | SEQ_A | POWER_END | | | | SYSTEM_END | | | |
| 96 | SEQ_B | PART_DOWN | | | | MAX_COUNT | | | |
| 97 | WAIT | WAIT_DIR | | TIME_OUT | WAIT_MODE | WAIT_TIME | | | |
| 98 | RESERVED | Reserved | Reserved | Reserved | Reserved | Reserved | Reserved | | |
| 99 | RESET | RESET_EVENT | | RESET_TIMER | | | | | |
| Regulator Setting Registers (REG) | | | | | | | | | |
| 9A | BUCK_ILIM_A | BMEM_ILIM | | | | BIO_ILIM | | | |
| 9B | BUCK_ILIM_B | BPERI_ILIM | | | | BPRO_ILIM | | | |
| 9C | BUCK_ILIM_C | BCORE2_ILIM | | | | BCORE1_ILIM | | | |
| 9D | BCORE2_CONF | BCORE2_MODE | | BCORE2_PD_DIS | Reserved | | BCORE2_FB | | |
| 9E | BCORE1_CONF | BCORE1_MODE | | BCORE1_PD_DIS | Reserved | | BCORE1_FB | | |
| 9F | BPRO_CONF | BPRO_MODE | | BPRO_PD_DIS | BPRO_VTT_EN | BPRO_VTTR_EN | BPRO_FB | | |
| A0 | BIO_CONF | BIO_MODE | | BIO_PD_DIS | Reserved | | BIO_FB | | |
| A1 | BMEM_CONF | BMEM_MODE | | BMEM_PD_DIS | Reserved | | BMEM_FB | | |
| A2 | BPERI_CONF | BPERI_MODE | | BPERI_PD_DIS | Reserved | | BPERI_FB | | |
| A3 | VBCORE2_A | BCORE2_SL_A | VBCORE2_A | | | | | | |
| A4 | VBCORE1_A | BCORE1_SL_A | VBCORE1_A | | | | | | |
| A5 | VBPRO_A | BCPRO_SL_A | VBPRO_A | | | | | | |
| A6 | VBMEM_A | BMEM_SL_A | VBMEM_A | | | | | | |
| A7 | VBIO_A | BIO_SL_A | VBIO_A | | | | | | |
| A8 | VBPERI_A | BPERI_SL_A | VBPERI_A | | | | | | |
| A9 | Reserved | Reserved | Reserved | Reserved | | | | | |

System PMIC for Mobile and Automotive Applications

| Hex | Register | 7 | 6 | 5 | 4 | 3 | 2 | 1 | 0 |
|-----|-----------|-------------|-----------|----------|---|---|---|---|---|
| AA | Reserved | Reserved | Reserved | Reserved | | | | | |
| AB | VLDO3_A | LDO3_SL_A | VLDO3_A | | | | | | |
| AC | RESERVED | Reserved | Reserved | | | | | | |
| AD | RESERVED | Reserved | Reserved | Reserved | | | | | |
| AE | RESERVED | Reserved | Reserved | Reserved | | | | | |
| AF | VLDO7_A | LDO7_SL_A | Reserved | VLDO7_A | | | | | |
| B0 | VLDO8_A | LDO8_SL_A | Reserved | VLDO8_A | | | | | |
| B1 | VLDO9_A | LDO9_SL_A | Reserved | VLDO9_A | | | | | |
| B2 | Reserved | Reserved | Reserved | Reserved | | | | | |
| B3 | VLDO11_A | LDO11_SL_A | Reserved | VLDO11_A | | | | | |
| B4 | VBCORE2_B | BCORE2_SL_B | VBCORE2_B | | | | | | |
| B5 | VBCORE1_B | BCORE1_SL_B | VBCORE1_B | | | | | | |
| B6 | VBPRO_B | BCPRO_SL_B | VBPRO_B | | | | | | |
| B7 | VBMEM_B | BMEM_SL_B | VBMEM_B | | | | | | |
| B8 | VBIO_B | BIO_SL_B | VBIO_B | | | | | | |
| B9 | VBPERI_B | BPERI_SL_B | VBPERI_B | | | | | | |
| BA | RESERVED | Reserved | Reserved | Reserved | | | | | |
| BB | RESERVED | Reserved | Reserved | Reserved | | | | | |
| BC | VLDO3_B | LDO3_SL_B | VLDO3_B | | | | | | |
| BD | RESERVED | Reserved | Reserved | | | | | | |
| BE | RESERVED | Reserved | Reserved | Reserved | | | | | |
| BF | RESERVED | Reserved | Reserved | Reserved | | | | | |
| C0 | VLDO7_B | LDO7_SL_B | Reserved | VLDO7_B | | | | | |

System PMIC for Mobile and Automotive Applications

| Hex | Register | 7 | 6 | 5 | 4 | 3 | 2 | 1 | 0 |
|---|------------|------------|------------|------------|------------|------------|---|------------|---|
| C1 | VLDO8_B | LDO8_SL_B | Reserved | VLDO8_B | | | | | |
| C2 | VLDO9_B | LDO9_SL_B | Reserved | VLDO9_B | | | | | |
| C3 | RESERVED | Reserved | Reserved | Reserved | | | | | |
| C4 | VLDO11_B | LDO11_SL_B | Reserved | VLDO11_B | | | | | |
| Reserved | | | | | | | | | |
| C5 | RESERVED | Reserved | | | | Reserved | | | |
| Reserved | | | | | | | | | |
| C6 | RESERVED | Reserved | Reserved | | | | | | |
| C7 | RESERVED | Reserved | Reserved | | | | | | |
| C8 | RESERVED | Reserved | Reserved | | | | | | |
| GP-ADC Threshold Registers (GPADC) | | | | | | | | | |
| C9 | ADC_CONT | ADCIN3_DEB | ADCIN2_DEB | ADCIN1_DEB | ADCIN3_CUR | ADCIN2_CUR | | ADCIN1_CUR | |
| CA | AUTO1_HIGH | AUTO1_HIGH | | | | | | | |
| CB | AUTO1_LOW | AUTO1_LOW | | | | | | | |
| CC | AUTO2_HIGH | AUTO2_HIGH | | | | | | | |
| CD | AUTO2_LOW | AUTO2_LOW | | | | | | | |
| CE | AUTO3_HIGH | AUTO3_HIGH | | | | | | | |
| CF | AUTO3_LOW | AUTO3_LOW | | | | | | | |

System PMIC for Mobile and Automotive Applications

| Hex | Register | 7 | 6 | 5 | 4 | 3 | 2 | 1 | 0 |
|--|-----------|-------------------|-------------------|-------------------|------------------|--------------------|---------------------|-------------|-------------|
| PAGE 2 | | | | | | | | | |
| 100 | PAGE_CON | REVERT | WRITE_MODE | Reserved | | | REG_PAGE | | |
| OTP | | | | | | | | | |
| 101 | OTP_CONT | GP_WRITE_D IS | OTP_CONF_LO CK | OTP_APPS_LO CK | OTP_GP_LOCK | PC_DONE | OTP_APPS_RD | OTP_GP_RD | OTP_TIM |
| 102 | OTP_ADDR | OTP_ADDR | | | | | | | |
| 103 | OTP_DATA | OTP_DATA | | | | | | | |
| Customer Trim and Configuration Registers | | | | | | | | | |
| 104 | T_OFFSET | T_OFFSET | | | | | | | |
| 105 | INTERFACE | IF_BASE_ADDR | | | | R/W_POL | CPHA | CPOL | nCS_POL |
| 106 | CONFIG_A | IF_TYPE | PM_IF_HSM | PM_IF_FMP | PM_IF_V | IRQ_TYPE | PM_O_TYPE | PM_O_V | PM_I_V |
| 107 | CONFIG_B | CHG_CLK_M ODE | VDD_HYST_ADJ | | | VDD_FAULT_ADJ | | | |
| 108 | CONFIG_C | BPERI_CLK_I NV | BIO_CLK_INV | BMEM_CLK_INV | BPRO_CLK_I NV | BCORE1_CLK_I NV | BUCK_ACTV_D SCHG | LDO1_TRACK | |
| 109 | CONFIG_D | GP_FB3_TYPE | GP_FB2_TYPE | FORCE_RESET | HS_IF_HSM | HS_IF_FMP | SYSTEM_EN_RD | nIRQ_MODE | GPI_V |
| 10A | CONFIG_E | PERI_SW_A UTO | CORE_SW_A UTO | BPERI_AUTO | BIO_AUTO | BMEM_AUTO | BPRO_AUTO | BCORE2_AUTO | BCORE1_AUTO |
| 10B | CONFIG_F | LDO11_BYP | LDO8_BYP | LDO7_BYP | Reserved | LDO3_BYP | LDO11_AUTO | Reserved | LDO9_AUTO |
| 10C | CONFIG_G | LDO8_AUTO | LDO7_AUTO | Reserved | Reserved | Reserved | LDO3_AUTO | Reserved | Reserved |
| 10D | CONFIG_H | BUCK_MERGE | BCORE1_OD | BCORE2_OD | BPRO_OD | BCORE_MERGE | MERGE_SENSE | LDO8_MODE | PWM_CLK |
| 10E | CONFIG_I | LDO_SD | INT_SD_MODE | HOST_SD_M ODE | KEY_SD_M ODE | GPI14_15_SD | nONKEY_SD | nONKEY_PIN | |
| 10F | CONFIG_J | IF_RESET | TWOWIRE_TO | RESET_DURATION | | SHUT_DELAY | | KEY_DELAY | |
| 110 | CONFIG_K | GPI7_PUPD | GPI6_PUPD | GPI5_PUPD | GPI4_PUPD | GPI3_PUPD | GPI02_PUPD | GPI01_PUPD | GPI00_PUPD |

System PMIC for Mobile and Automotive Applications

| Hex | Register | 7 | 6 | 5 | 4 | 3 | 2 | 1 | 0 |
|---------------------------------------|-----------|------------------|-------------|--------------|------------------|-------------|--------------|--------------------|--------------------|
| 111 | CONFIG_L | GPIO15_PUPD | GPIO14_PUPD | GPIO13_PUPD | GPIO12_PUPD | GPIO11_PUPD | GPIO10_PUPD | GPIO9_PUPD | GPIO8_PUPD |
| 112 | CONFIG_M | OSC_FREQ | | Reserved | | | | | |
| 113 | CONFIG_N | Reserved | | | | | | | |
| 114 | MON_REG_1 | UVOV_DELAY | | MON_MODE | | MON_DEB | MON_RES | MON_THRES | |
| 115 | MON_REG_2 | LDO8_MON_EN N | LDO7_MON_EN | Reserved | Reserved | Reserved | LDO3_MON_EN | Reserved | Reserved |
| 116 | MON_REG_3 | Reserved | | | | | LDO11_MON_EN | Reserved | LDO9_MON_EN |
| 117 | MON_REG_4 | Reserved | | BPERI_MON_EN | BMEM_MON_EN N | BIO_MON_EN | BPRO_MON_EN | BCORE2_MON_EN N | BCORE1_MON_EN N |
| 118 | RESERVED | Reserved | | | | | | | |
| 119 | RESERVED | Reserved | | | | | | | |
| 11A | RESERVED | Reserved | | | | | | | |
| 11B | RESERVED | Reserved | | | | | | | |
| 11C | RESERVED | Reserved | | | | | | | |
| 11D | RESERVED | Reserved | | | | | | | |
| 11E | MON_REG_5 | Reserved | MONA9_IDX | | | Reserved | MONA8_IDX | | |
| 11F | MON_REG_6 | Reserved | | | | | MONA10_IDX | | |
| 120 | TRIM_CLDR | TRIM_CLDR | | | | | | | |
| General Purpose Registers (GP) | | | | | | | | | |
| 121 | GP_ID_0 | GP_0 | | | | | | | |
| 122 | GP_ID_1 | GP_1 | | | | | | | |
| 123 | GP_ID_2 | GP_2 | | | | | | | |
| 124 | GP_ID_3 | GP_3 | | | | | | | |
| 125 | GP_ID_4 | GP_4 | | | | | | | |

System PMIC for Mobile and Automotive Applications

| Hex | Register | 7 | 6 | 5 | 4 | 3 | 2 | 1 | 0 |
|---------------------------------|----------|---|---|---|---|----------|---|---|---|
| 126 | GP_ID_5 | | | | | GP_5 | | | |
| 127 | GP_ID_6 | | | | | GP_6 | | | |
| 128 | GP_ID_7 | | | | | GP_7 | | | |
| 129 | GP_ID_8 | | | | | GP_8 | | | |
| 12A | GP_ID_9 | | | | | GP_9 | | | |
| 12B | GP_ID_10 | | | | | GP_10 | | | |
| 12C | GP_ID_11 | | | | | GP_11 | | | |
| 12D | RESERVED | | | | | RESERVED | | | |
| 12E | RESERVED | | | | | RESERVED | | | |
| 12F | RESERVED | | | | | RESERVED | | | |
| 130 | RESERVED | | | | | RESERVED | | | |
| 131 | RESERVED | | | | | RESERVED | | | |
| 132 | RESERVED | | | | | RESERVED | | | |
| 133 | RESERVED | | | | | RESERVED | | | |
| 134 | RESERVED | | | | | RESERVED | | | |
| Internal Debug Registers | | | | | | | | | |
| 135 | RESERVED | | | | | Reserved | | | |
| 136 | RESERVED | | | | | Reserved | | | |
| 137 | RESERVED | | | | | Reserved | | | |
| 138 | RESERVED | | | | | Reserved | | | |
| 139 | RESERVED | | | | | Reserved | | | |
| 13A | RESERVED | | | | | Reserved | | | |
| 13B | RESERVED | | | | | Reserved | | | |

System PMIC for Mobile and Automotive Applications

| Hex | Register | 7 | 6 | 5 | 4 | 3 | 2 | 1 | 0 |
|--------------------------------------|-------------|------------|------------|----------|---|--------|----------|---|---|
| 13C | RESERVED | Reserved | | | | | | | |
| 13D | RESERVED | Reserved | | | | | | | |
| 13E | RESERVED | Reserved | | | | | | | |
| PAGE 3 | | | | | | | | | |
| 180 | PAGE_CON | REVERT | WRITE_MODE | Reserved | | | REG_PAGE | | |
| Chip Identification Registers | | | | | | | | | |
| 181 | DEVICE_ID | DEVICE_ID | | | | | | | |
| 182 | VARIANT_ID | MRC | | | | VRC | | | |
| 183 | CUSTOMER_ID | CUST_ID | | | | | | | |
| 184 | CONFIG_ID | CONFIG_REV | | | | | | | |
| 1A8 | PMIC_STATUS | PC_DONE | Reserved | | | Status | | | |

Most register bits are reset to defaults (zero in most cases) when powering up from RESET mode. An exception is for example FAULT_LOG that is not loaded from OTP. Register fields shown in BOLD are loaded from OTP.

System PMIC for Mobile and Automotive Applications

8 Definitions

8.1 Power Dissipation and Thermal Design

When designing with the DA9063L, consideration must be given to power dissipation as the level of integration of the device can result in high power when all functions are operating with high battery voltages. Exceeding the package power dissipation capabilities results in the internal thermal sensor shutting down the device until it has sufficiently cooled.

The package includes a thermal management paddle to improve heat spreading into the PCB.

For Linear Regulators:

Linear regulators operating with a high current and high differential voltage between input and output dissipate the following power:

$$P_{diss} = (V_{in} - V_{out}) \times I_{out}$$

Example: a regulator supplying 150 mA at 2.8 V from a fully-charged lithium battery (VDD=4.1 V):

$$P_{diss} = (4.1V - 2.8V) \times 0.15A = 195mW$$

For Switching Regulators:

$$P_{out} = P_{in} \times Efficiency$$

Therefore,

$$P_{diss} = P_{in} - P_{out}$$

$$P_{diss} = \frac{P_{out}}{Efficiency} - P_{out}$$

$$P_{diss} = P_{out} \times \left(\frac{1}{Efficiency} - 1 \right)$$

$$P_{diss} = I_{out} \times V_{out} \times \left(\frac{1}{Efficiency} - 1 \right)$$

Example: an 85 % efficient buck converter supplying 1.2 V at 400 mA:

$$P_{diss} = 1.2V \times 0.4A \times \left(\frac{1}{0.85} - 1 \right) = 85mW$$

As the DA9063L has multiple regulators, each supply must be separately considered and their powers summed to give the total device dissipation (current drawn from the reference and control circuitry can be considered negligible in these calculations).

System PMIC for Mobile and Automotive Applications

8.2 Regulator Parameter - Dropout Voltage

In the DA9063L, a regulator's dropout voltage is defined as the minimum voltage differential between the input and output voltages whilst regulation still takes place. Within the regulator, voltage control takes place across a PMOS pass transistor and, when entering the dropout condition, the transistor is fully turned on and therefore cannot provide any further voltage control. When the transistor is fully turned on, the output voltage tracks the input voltage and regulation ceases. As the DA9063L is a CMOS device and uses a PMOS pass transistor, the dropout voltage is directly related to the on-resistance of the device. In the device, the pass transistors are sized to provide the optimum balance between required performance and silicon area. By employing a 0.25 μm process, Dialog Semiconductor is able to achieve very small pass transistor sizes for superior performance.

$$V_{\text{dropout}} = V_{\text{in}} - V_{\text{out}} = R_{\text{dson}} \times I_{\text{out}}$$

When defining dropout voltage, it is specified in relation to a minimum acceptable change in output voltage. For example, all Dialog Semiconductor regulators have dropout voltage defined as the point at which the output voltage drops 10 mV below the output voltage at the minimum guaranteed operating voltage. The worst case conditions for dropout are high temperature (highest on-resistance for the internal pass device) and maximum current load.

8.3 Regulator Parameter - Power Supply Rejection

Power supply rejection (PSRR) is especially important in the supplies to the RF and audio parts of the telephone. In a TDMA system such as GSM, the 217 Hz transmit burst from the power amplifier results in significant current pulses being drawn from the battery. These can peak at up to 2 A before reaching a steady state of 1.4 A (see below). Due to the battery having a finite internal resistance (typically 0.5 Ω), these current peaks induce ripple on the battery voltage of up to 500 mV. Since the supplies to the audio and RF are derived from this supply, it is essential that this ripple is removed otherwise it would show as a 217 Hz tone in the audio and could also affect the transmit signal. Power supply rejection should always be specified under worst case conditions – when the battery is at its minimum operating voltage and when there is minimum headroom available due to dropout.

8.4 Regulator Parameter - Line Regulation

Static line regulation is a measurement that indicates a change in the regulator output voltage, ΔV_{reg} (regulator operating with a constant load current), in response to a change in the input voltage, ΔV_{in} . Transient line regulation is a measurement of the peak change, ΔV_{reg} , in regulated voltage seen when the line input voltage changes.

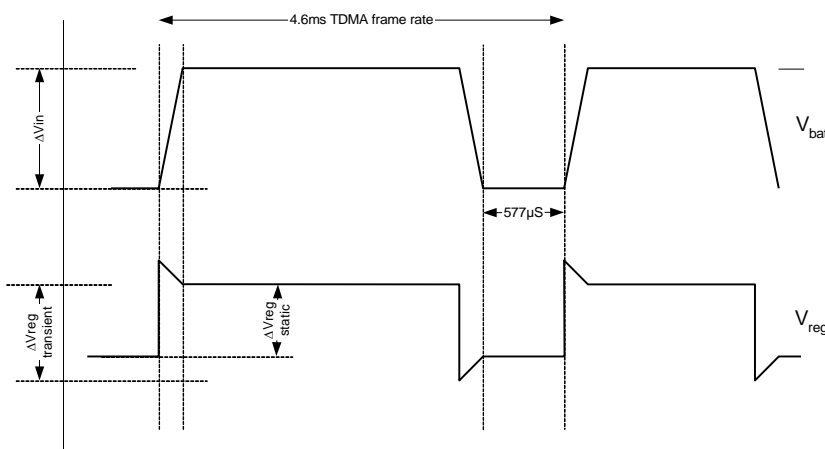

Figure 33: Line Regulation

System PMIC for Mobile and Automotive Applications

8.5 Regulator Parameter - Load Regulation

Static load regulation is a measurement that indicates a change in the regulator output voltage, ΔV_{reg} , in response to a change in the regulator loading, ΔI_{load} , whilst the regulator input voltage remains constant. Transient load regulation is a measurement of the peak change in regulated voltage, ΔV_{reg} , seen when the regulator load changes.

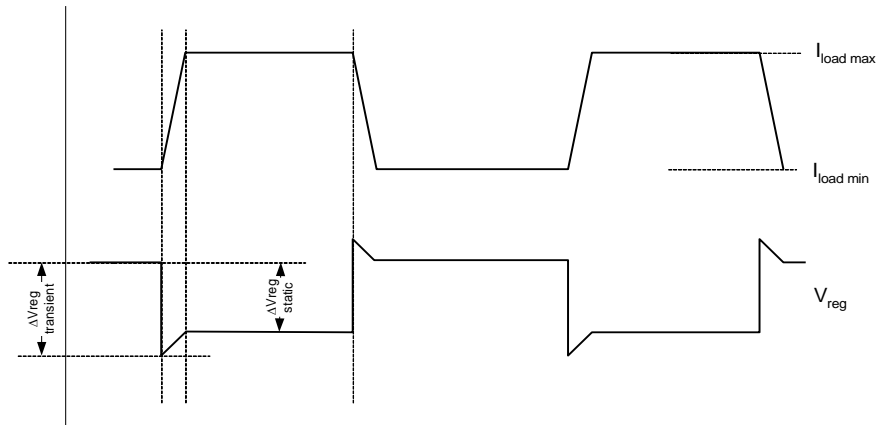

Figure 34: Load Regulation

Please contact Dialog Semiconductor for latest application information on the DA9063L and other power management devices.

System PMIC for Mobile and Automotive Applications

9 Package Information

9.1 Package Outlines

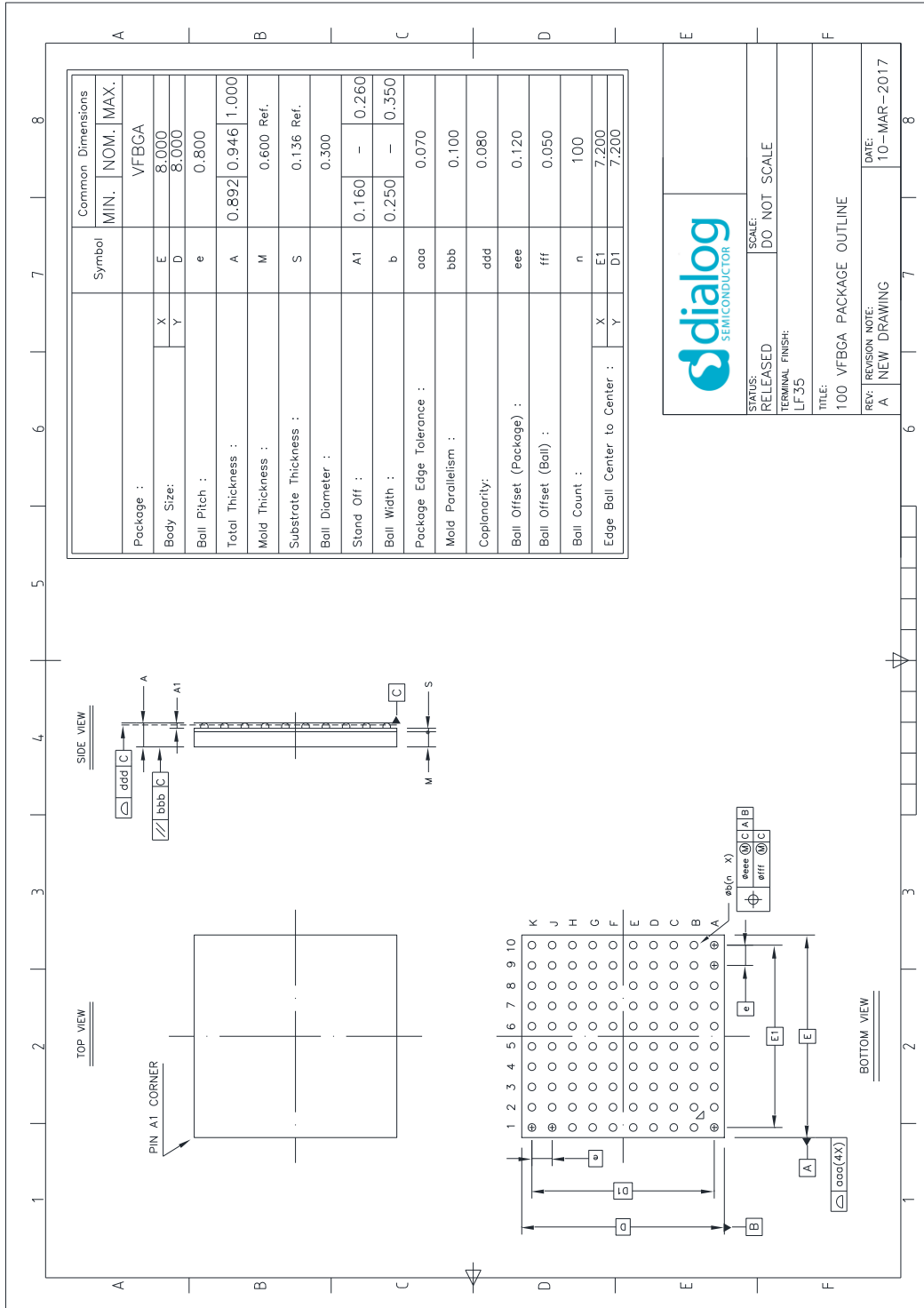

Figure 35: Package Outline Drawing 100 VFBGA 0.3 mm Ball Diameter

System PMIC for Mobile and Automotive Applications

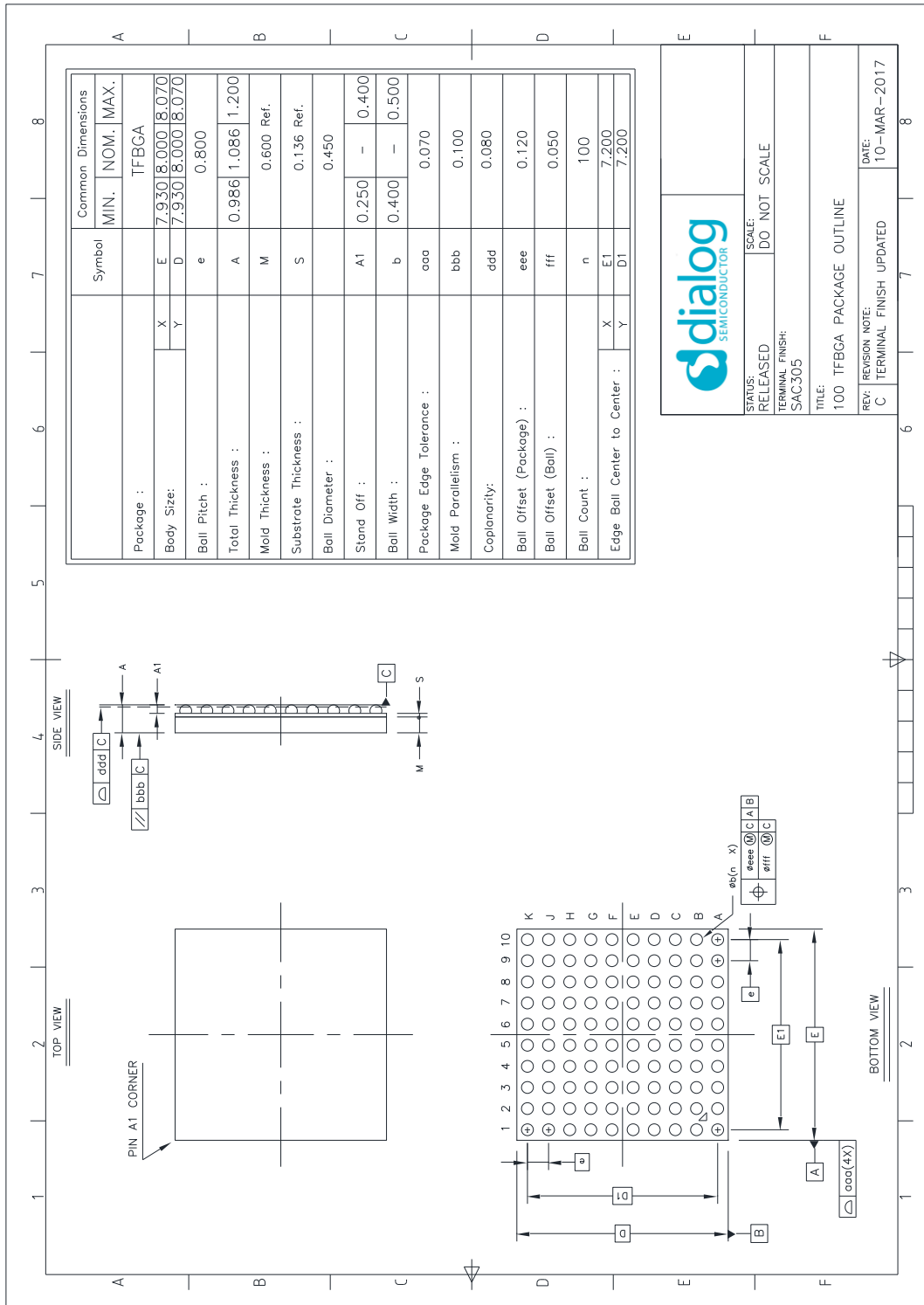

Figure 36: Package Outline Drawing 100 TFBGA 0.45 mm Ball Diameter

System PMIC for Mobile and Automotive Applications

9.2 Package Marking

| Package Marking | | |
|--|-----------------|----------------------------|
| A1 Corner > | Marking Content | Format |
| 1st | | Orientation |
| 2nd | | Logo |
| 3rd | | Part No. |
| 4th | | OTP/Silicon Version/Option |
| 5th | | Date Code |
| Date Code Format: yy = Year, ww = Week, zzzz = Traceability | | |
| xx identifies the OTP Variant, vv may be used to show the silicon version. | | |
| -A and -AT optionally indicate the Automotive and Automotive high temp test options. | | |

9.3 Moisture Sensitivity Level

The Moisture Sensitivity Level (MSL) is an indicator for the maximum allowable time period (floor lifetime) in which a moisture sensitive plastic device, once removed from the dry bag, can be exposed to an environment with a specified maximum temperature and a maximum relative humidity before the solder reflow process. The MSL classification is defined in [Table 37](#).

For detailed information on MSL levels refer to the IPC/JEDEC standard J-STD-020, which can be downloaded from <http://www.jedec.org>.

The VFBGA and TFBGA packages are qualified for MSL 3.

Table 37: MSL Classification

| MSL Level | Floor Lifetime | Conditions |
|-----------|----------------|-----------------|
| MSL 4 | 72 hours | 30 °C / 60 % RH |
| MSL 3 | 168 hours | 30 °C / 60 % RH |
| MSL 2A | 4 weeks | 30 °C / 60 % RH |
| MSL 2 | 1 year | 30 °C / 60 % RH |
| MSL 1 | Unlimited | 30 °C / 85 % RH |

System PMIC for Mobile and Automotive Applications

10 Ordering Information

The ordering number consists of the part number followed by a suffix indicating the packing method. For details and availability, please consult Dialog Semiconductor's [website](#) or your local sales representative.

Table 38: Ordering Information

| Part Number | Package | Shipment Form | Pack Quantity |
|---|---|---------------|---------------|
| Consumer: 0.30 mm ball diameter, RT production testing | | | |
| DA9063L-xxHK1 Note 2 | 100 VFBGA, 8.0 mm x 8.0 mm x 1.0 mm, 0.8 mm pitch, Pb-free/green | Tray | 260 |
| DA9063L-xxHK2 Note 2 | 100 VFBGA, 8.0 mm x 8.0 mm x 1.0 mm, 0.8 mm pitch, Pb-free/green | T&R | 2500 |
| Consumer / Industrial: 0.45 mm ball diameter, RT production testing | | | |
| DA9063L-xxHO1 | 100 TFBGA, 8.0 mm x 8.0 mm x 1.2 mm, 0.8 mm pitch, Pb-free/green | Tray | 260 |
| DA9063L-xxHO2 | 100 TFBGA, 8.0 mm x 8.0 mm x 1.2 mm, 0.8 mm pitch, Pb-free/green | T&R | 2500 |
| Automotive AEC-Q100 Grade 2: 0.45 mm ball diameter, RT production testing Note 1 | | | |
| DA9063L-xxHO1-A | 100 TFBGA, 8.0 mm x 8.0 mm x 1.2 mm, 0.8 mm pitch, Pb-free/green | Tray | 260 |
| DA9063L-xxHO2-A | 100 TFBGA, 8.0 mm x 8.0 mm x 1.2 mm, 0.8 mm pitch, Pb-free/green | T&R | 2500 |
| Automotive AEC-Q100 Grade 2: 0.45 mm ball diameter, HT production testing Note 1 | | | |
| DA9063L-xxHO1-AT | 100 TFBGA, 8.0 mm x 8.0 mm x 1.2 mm, 0.8 mm pitch, Pb-free/green | Tray | 260 |
| DA9063L-xxHO2-AT | 100 TFBGA, 8.0 mm x 8.0 mm x 1.2 mm, 0.8 mm pitch, Pb-free/green | T&R | 2500 |

Note 1 Operating temperature is defined in Section 5.2. Automotive qualification temperature is defined by the Automotive Electronics Council AEC-Q100 specification.

Note 2 The 0.30 mm ball diameter version is not recommended for new designs.

10.1 Variants Ordering Information

DA9063L supports delivery of variants indicated by xx in the Part number above, where xx is replaced with the actual variant number. Please contact your local Dialog Semiconductor office or representative to discuss requirements.

All Dialog automotive power management products that are AEC-Q100 qualified have an -A or -AT suffix for dual temperature production test.

System PMIC for Mobile and Automotive Applications

11 Application Information

The following recommended components are examples selected from requirements of a typical application. The electrical characteristics (for example, supported voltage/current range) have to be cross-checked and component types may need to be adapted from the individual needs of the target circuitry.

11.1 Capacitor Selection

Ceramic capacitors are used as bypass capacitors at all VDD and output rails. When selecting a capacitor, especially for types with high capacitance at smallest physical dimension, the DC bias characteristic has to be taken into account. On the V_{sys} main supply rail a minimum distributed capacitance of 40 µF (actual capacitance after voltage and temperature derating) is required. For example, a typical design might use:

- 22 µF within 1.5 mm of each BUCKCORE1, BUCKCORE2 and BUCKPRO supply pin.
- 10 µF within 1.5 mm of each BUCKPERI, BUCKIO and BUCKMEM supply pin or 1 µF x 22 µF if all are attached to a PCB power/split plane.
- 2 µF x 1 µF shared by all VDD_LDOx pins if they are all close together, for example, all attached to a power/split plane.
- 1 µF close to the V_{sys} pin.
- Buck output capacitors should be close to the buck inductors.

The amount of decoupling required will be dependent on the specific application.

Table 39: Recommended Capacitor Types

| Application | Value | Tol. (%) | Size | Height (mm) | Temp. Char. | Rated Voltage (V) | Type (Murata/Samsung) |
|---|---------|----------|------|-------------|-------------|-------------------|---|
| VDDCORE, VLDO3, VLDO7, VLDO8, VLDO9, VLDO11 | 2.2 µF | ± 20 | 0402 | 0.55 | X5R ±15 % | 6.3 | GRM155R60J225ME95 |
| VBUCKPER, VBUCKIO, VBUCKMEM, V _{sys} | 22 µF | ± 20 | 0805 | 0.95 | X5R ±15 % | 6.3 | GRM219R60J226M*** |
| | | ± 20 | 0402 | 0.5 | X5R ±15 % | 4.0 | CL05A226MR5NZNC |
| | 47 µF | ± 20 | 0805 | 0.95 | X5R ±15 % | 4.0 | GRM219R60G476M*** |
| | | ± 20 | 0603 | 0.8 | X5R ±15 % | 4.0 | CL10A476MR8NZN |
| VBUCKCORE 1 and 2, VBUCKPRO (using full-current mode) | 22 µF | ± 20 | 0603 | 1.0 | X5R ±15 % | 6.3 | GRM188R60J226MEA0 Note 1 |
| | | ± 20 | 0402 | 0.5 | X5R ±15 % | 4.0 | CL05A226MR5NZNC |
| | 47 µF | ± 20 | 0805 | 0.95 | X5R ±15 % | 4.0 | GRM219R60G476M***61 |
| | | ± 20 | 0603 | 0.8 | X5R ±15 % | 4.0 | CL10A476MR8NZN |
| V _{sys} | 1.0 µF | ± 10 | 0402 | 0.5 | X5R ±15 % | 10 | GRM155R61A105KE15 |
| V _{BAT} | 470 nF | ± 10 | 0402 | 0.5 | X5R ±15 % | 50 | GRM155R61A474KE11 |
| V _{REF} , VL _{NREF} | 0.22 µF | ± 10 | 0402 | 0.5 | X/R ±15 % | 16 | GRM155R71C224KA12 |

System PMIC for Mobile and Automotive Applications

| Application | Value | Tol. (%) | Size | Height (mm) | Temp. Char. | Rated Voltage (V) | Type (Murata/Samsung) |
|-------------|-------------|----------|------|-------------|----------------|-------------------|-----------------------|
| VDDCORE | 2.2 μ F | \pm 20 | 0402 | 0.5 | X5R \pm 15 % | 6.3 | GRM155R60J225ME95 |
| XIN, XOUT | 12 pF | \pm 5 | 0402 | 0.5 | C0G | 50 | GRM1555C1H120JA01D |
| V_CP | 47 nF | \pm 10 | 0402 | 0.5 | X7R \pm 15 % | 10 | GRM155R71A473KA01 |

Note 1 For output voltages > 1.4 V Murata GRM219R60J226M*** is recommended.

Table 40: Recommended Automotive Capacitor Types

| Application | Value | Tol. (%) | Size | Height (mm) | Temp. Char. | Rated Voltage (V) | Type (Murata/Samsung) |
|---|--------------|----------|------|-------------|-------------|-------------------|-----------------------|
| VDDCORE, VLDO3, VLDO7, VLDO8, VLDO9, VLDO11 | 2.2 μ F | \pm 20 | 0402 | 1.25 | X7R | 10 | GCM21BR71A225MA37 |
| VBUCKPER, VBUCKIO, VBUCKMEM, VSYS | 22 μ F | \pm 20 | 1206 | 1.6 | X7R | 6.3 | GCM31CR70J226ME23 |
| | 47 μ F | \pm 10 | 1206 | 1.6 | X7R | 6.3 | GCM32ER70J476KE19 |
| VBUCKCORE 1 and 2, VBUCKPRO (using full-current mode) | 22 μ F | \pm 20 | 1206 | 1.6 | X7R | 6.3 | GCM31CR70J226ME23 |
| | 47 μ F | \pm 10 | 1206 | 1.6 | X7R | 6.3 | GCM32ER70J476KE19 |
| VSYS | 10 μ F | \pm 10 | 0805 | 1.25 | X7R | 10 | GCM21BR71A106ME22 |
| | 1.0 μ F | \pm 10 | 0805 | 1.25 | X7R | 16 | GCM21BR71C105KA58 |
| VBBAT | 470 nF | \pm 10 | 0402 | 0.5 | X7R | 10 | GCM155C71A474KE36D |
| VREF, VLNREF | 0.22 μ F | \pm 10 | 0402 | 0.5 | X7R | 16 | GCM155R71C224ME02 |
| VDDCORE | 2.2 μ F | \pm 20 | 0402 | 1.25 | X7R | 10 | GCM21BR71A225MA37 |
| XIN, XOUT | 12 pF | \pm 5 | 0402 | 0.5 | C0G | 50 | GRM1555C1H120JA01D |
| V_CP | 47 nF | \pm 10 | 0402 | 0.5 | X7R | 10 | GRM155R71A473KA01 |

11.2 Inductor Selection

Inductors should be selected based upon the following parameters:

- Rated maximum current: Usually a coil provides two current limits: ISAT of an Inductor specifies the current required to cause a reduction in the Inductance by a specified amount, typically 30 %, IRMS of an Inductor specifies the current required to affect a temperature rise of a maximum specified amount.
- DC resistance: Critical to converter efficiency at high current and should therefore be minimized.

System PMIC for Mobile and Automotive Applications

- ESR at the buck switching frequency: Critical to converter efficiency in PFM mode and should therefore be minimized.
- Inductance: Given by converter electrical characteristics; 1.0 μH for all DA9063L switched-mode step-down converters.

Table 41: Recommended Inductor Types

| Application | Value (μH) | Tol. (%) | ISAT (A) | IRMS (A) | DCR (Typ.) (m Ω) | Size (mm) | Type |
|---|-------------------------|----------|----------|----------|--------------------------|-------------|--|
| BUCKPERI, BUCKMEM, BUCKIO, BUCKCORE1, BUCKCORE2 | 1.0 | ± 30 | 2.7 | 2.3 | 55 | 2.0x1.6x1.0 | Toko 1285AS-H-1R0N |
| | | ± 20 | 2.65 | 2.45 | 60 | 2.0x1.6x1.0 | Tayo Yuden MAKK2016T1R0M (Reference) |
| | | ± 20 | 3.9 | 3.1 | 50 | 2.0x1.6x1.0 | TDK TFM201610ALM- 1R0MTAA |
| BUCKPRO, BUCKCORE1 and 2 using full-current mode or merged BUCKMEM/ BUCKIO | 1.0 | ± 30 | 3.4 | 3.0 | 60 | 2.5x2.0x1.0 | Toko 1269AS-H-1R0N |
| | | ± 20 | 3.6 | 3.1 | 45 | 2.5x2.0x1.2 | Tayo Yuden MAMK2520T1R0M |
| | | ± 20 | 3.8 | 3.5 | 45 | 2.5x2.0x1.2 | Toko 1239AS-H-1R0N (Reference) |
| | | ± 30 | 3.9 | 3.1 | 48 | 3.2x2.5x1.0 | Toko 1276AS-H-1R0N |
| | | ± 20 | 4.5 | 3.6 | 38 | 2.5x2.0x1.0 | TDK TFM252010ALM- 1R0MTAA |
| | | ± 20 | 4.2 | 3.7 | 35 | 2.5x2.0x1.2 | TDK TFM252012ALMA- 1R0MTAA (AECQ200) |
| | | ± 20 | 3.35 | 2.5 | 52 | 3.0x3.0x1.2 | Cyntec PST031B-1R0MS |
| | | ± 20 | 8.8 | 12.0 | 8.2 | 4.0x4.0x2.1 | Coilcraft XGL4020-102ME (AEC- Q200) |

11.3 Resistors

Table 42: Recommended Resistor Types

| Application | Value | Size | Tolerance | P _{MAX} | Type |
|-----------------------------|----------------|------|-----------|------------------|---------------------------|
| IREF bias current reference | 200 k Ω | 0402 | $\pm 1\%$ | 100 mW | Panasonic ERJ2RKF2003x |

System PMIC for Mobile and Automotive Applications

12 Layout Guidelines

12.1 General Recommendations

- Appropriate trace width and quantity of vias should be used for all power supply paths. Too high trace resistances can prevent the system from achieving the best performance, for example, the efficiency and the current ratings of switch-mode converters and charger might be degraded. Furthermore, the PCB may be exposed to thermal hot spots, which can lead to critical overheating due to the positive temperature coefficient of copper.
Special care must be taken with the DA9063L pad connections. The traces of the outer row should be connected with the same width as the pads and should become wider as soon as possible. For supply pins in the second row, connection to an inner board layer is recommended (depending on the maximum current two or more vias might be required).
- A common ground plane should be used, which allows proper electrical and thermal performance. Noise sensitive references such as the VREF/VLNREF capacitors and IREF resistor should be referred to a silent ground which is connected at a star point underneath or close to the DA9063L main ground connection.
- Generally, all power tracks with discontinuous/high currents should be kept as short as possible.
- Noise sensitive analog signals such as feedback lines or crystal connections should be kept away from traces carrying pulsed analog or digital signals. This can be achieved by separation (distance) or shielding with quiet signals or ground traces.

12.2 LDOs and Switched Mode Supplies

- The placement of the distributed capacitors on the V_{SYS} rail must ensure that all VDD inputs – and especially to the V_{SYS} pin, the buck converters and LDOs – are connected to a bypass capacitor close to the pads. It is recommended placing at least two 1 μ F capacitors close to the LDO supply pads and at least one 10 μ F close to the buck VDD rail.
Using a local power plane underneath the chip for V_{SYS} might be considered.
- Transient current loops in the area of the switched mode converters should be minimised.
- The common references (IREF resistor, VREF/VLNREF capacitors) should be placed close to the DA9063L and cross coupling to any noisy digital or analog trace must be avoided.
- Output capacitors of the LDOs can be placed close to the input pins of the supplied devices (remote from the DA9063L).
- Care must be taken with trace routing to ensure that no current is carried on feedback lines of the buck output voltages V_{BUCK} .
- The inductor placement is less critical since parasitic inductances have negligible effect.

12.3 Thermal Connection, Land Pad, and Stencil Design

- The DA9063L provides a central ground area of balls, which are soldered to the PCB's central ground pad. This PCB ground pad must be connected with as many vias and as direct as possible to the PCB's main ground plane in order to achieve good thermal performance.
- Solder mask openings for the ball landing pads must be arranged to prohibit solder balls flowing into vias.

For further PCB layout guidance, see PCB Layout Guidelines [3].

System PMIC for Mobile and Automotive Applications

Appendix A Register Descriptions

This appendix describes the registers summarized in Section 7.

A.1 Register Page Control

Table 43: PAGE_CON

| Register Address | Bit | Type | Label | Description |
|------------------|-----|------|------------|---|
| 0x00 PAGE_CON | 7 | R/W | REVERT | Resets REG_PAGE to 00 after read/write access has finished |
| | 6 | R/W | WRITE_MODE | 2-WIRE multiple write mode 0: Page Write Mode 1: Repeated Write Mode |
| | 5:3 | R/W | Reserved | |
| | 2:0 | R/W | REG_PAGE | 000: Selects Register 0x01 to 0x3F 001: Selects Register 0x81 to 0xCF 010: Selects Register 0x101 to 0x13F 011: Reserved for production and test |

The PAGE_CON register is located at address 0x00 of each register page (0x00 and 0x80). The control interface provides an individual instance of the PAGE_CON register.

A.2 Register Page 0

A.2.1 Power Manager Control and Monitoring

The STATUS register reports the current value of the various signals at the time that it is read out. All the status bits have the same polarity as their corresponding signals.

Table 44: STATUS_A

| Register Address | Bit | Type | Label | Description |
|------------------|-----|------|----------|--|
| 0x01 STATUS_A | 7:4 | R | Reserved | |
| | 3 | R | COMP1V2 | Output state of 1.2 V comparator |
| | 2 | R | DVC | Asserted as long as at least one DVC supply performs voltage ramping |
| | 1 | R | WAKE | CHG_WAKE level |
| | 0 | R | nONKEY | Asserted as long nONKEY is pressed (low level) |

Table 45: STATUS_B

| Register Address | Bit | Type | Label | Description |
|------------------|-----|------|-------|-------------|
| 0x02 STATUS_B | 7 | R | GPI7 | GPI7 level |
| | 6 | R | GPI6 | GPI6 level |
| | 5 | R | GPI5 | GPI5 level |
| | 4 | R | GPI4 | GPI4 level |

System PMIC for Mobile and Automotive Applications

| Register Address | Bit | Type | Label | Description |
|------------------|-----|------|-------|---|
| | 3 | R | GPI3 | GPI3 level |
| | 2 | R | GPI2 | GPI2 level or ADCIN3 threshold indicator (1 when overriding high limit) |
| | 1 | R | GPI1 | GPI1 level or ADCIN2 threshold indicator (1 when overriding high limit) |
| | 0 | R | GPI0 | GPI0 level or ADCIN1 threshold indicator (1 when overriding high limit) |

Table 46: STATUS_C

| Register Address | Bit | Type | Label | Description |
|------------------|-----|------|-------|--------------------------------|
| 0x03 STATUS_C | 7 | R | GPI15 | GPI15 level |
| | 6 | R | GPI14 | GPI14 level |
| | 5 | R | GPI13 | GPI13/ EXT_WAKEUP/READY level |
| | 4 | R | GPI12 | GPI12/nVDD_FAULT/VDD_MON level |
| | 3 | R | GPI11 | GPI11 level |
| | 2 | R | GPI10 | GPI10/PWR1_EN level |
| | 1 | R | GPI9 | GPI9/PWR_EN level |
| | 0 | R | GPI8 | GPI8/SYS_EN level |

Table 47: STATUS_D

| Register Address | Bit | Type | Label | Description |
|------------------|-----|------|-----------|--|
| 0x04 STATUS_D | 7 | R/W | LDO11_LIM | Asserted as long LDO11 hits its over-current limit |
| | 6 | R/W | LDO8_LIM | Asserted as long LDO8 hits its over-current limit |
| | 5 | R/W | LDO7_LIM | Asserted as long LDO7 hits its over-current limit |
| | 4 | R/W | Reserved | |
| | 3 | R/W | LDO3_LIM | Asserted as long LDO3 hits its over-current limit |
| | 2:0 | R/W | Reserved | |

Table 48: FAULT_LOG

| Register Address | Bit | Type | Label | Description |
|-------------------|-----|------|------------|---|
| 0x05 FAULT_LOG | 7 | R | WAIT_SHUT | Power down by time out of ID WAIT |
| | 6 | R | nSHUT_DOWN | Power down by assertion of port nOFF, nSHUTDOWN |
| | 5 | R | KEY_RESET | Power down from a long press of nONKEY or GPIO14/15 |

System PMIC for Mobile and Automotive Applications

| Register Address | Bit | Type Note 1 | Label | Description |
|------------------|-----|----------------|-----------|---|
| | 4 | R | TEMP_CRIT | Junction over-temperature detected |
| | 3 | R | VDD_START | Power down by V_{SYS} under-voltage detect before or within 16 seconds after entering ACTIVE mode |
| | 2 | R | VDD_FAULT | Power down by V_{SYS} under-voltage detect |
| | 1 | R | POR | DA9063L starts up from NO-POWER or DELIVERY mode |
| | 0 | R | TWD_ERROR | Watchdog time violated |

Note 1 Cleared from the host by writing back the read value.

The EVENT registers hold information about events that have occurred in the DA9063L. Events are triggered by a change in the status registers that contains the status of monitored signals. When an EVENT bit is set in the event register the nIRQ signal is asserted (unless the nIRQ is to be masked by a bit in the IRQ mask register). The nIRQ is also masked during the power-up sequence and is not released until the event registers have been cleared. The IRQ triggering event register is cleared from the host by writing back its read value. The event registers may be read in page/repeated mode. New events that occur during clearing are delayed before they are passed to the event register, ensuring that the host controller does not miss them.

Table 49: EVENT_A

| Register Address | Bit | Type | Label | Description |
|------------------|-----|-------------|-----------|--|
| 0x06 EVENT_A | 7 | R | EVENTS_D | Asserted when register EVENT_B to EVENT_D have at least one event bit asserted |
| | 6 | R | EVENTS_C | Asserted when register EVENT_B to EVENT_C have at least one event bit asserted |
| | 5 | R | EVENTS_B | Asserted when register EVENT_B has at least one event bit asserted |
| | 4 | R Note 1 | E_SEQ_RDY | Sequencer reached final position caused event |
| | 3 | R Note 1 | E_ADC_RDY | ADC manual conversion result ready caused event |
| | 2:1 | R Note 1 | Reserved | |
| | 0 | R Note 1 | E_nONKEY | nONKEY caused event |

Note 1 Cleared from the host by writing back the read value.

Table 50: EVENT_B

| Register Address | Bit | Type Note 1 | Label | Description |
|------------------|-----|----------------|------------|---|
| 0x07 EVENT_B | 7 | R | E_VDD_WARN | V_{SYS} dropped below VDD_FAULT_UPPER threshold |
| | 6 | R | E_VDD_MON | V_{SYS} less or higher than VSYS_MON threshold caused event |
| | 5 | R | E_DVC_RDY | Finish of all DVC voltage ramping event |

System PMIC for Mobile and Automotive Applications

| Register Address | Bit | Type Note 1 | Label | Description |
|------------------|-----|----------------|------------|--|
| | 4 | R | E_REG_UVOV | Event triggered from a monitored regulator voltage being out of selected range or from new regulator voltage measurement being available (depends on settings of MON_MODE) |
| | 3 | R | E_LDO_LIM | LDO3, 7, 8 or 11 current limit exceeded for more than 10 ms |
| | 2 | R | E_COMP1V2 | 1.2 V comparator caused event |
| | 1 | R | E_TEMP | Junction high temp caused event |
| | 0 | R | E_WAKE | Detected rising edge on CHG_WAKE |

Note 1 Cleared from the host by writing back the read value.

Table 51: EVENT_C

| Register Address | Bit | Type Note 1 | Label | Description |
|------------------|-----|----------------|--------|---|
| 0x08 EVENT_C | 7 | R | E_GPI7 | GPI event according to active state setting |
| | 6 | R | E_GPI6 | GPI event according to active state setting |
| | 5 | R | E_GPI5 | GPI event according to active state setting |
| | 4 | R | E_GPI4 | GPI event according to active state setting |
| | 3 | R | E_GPI3 | GPI event according to active state setting |
| | 2 | R | E_GPI2 | GPI event according to active state setting / ADCIN3 high / low threshold exceeded caused event |
| | 1 | R | E_GPI1 | GPI event according to active state setting / ADCIN2 high / low threshold exceeded caused event |
| | 0 | R | E_GPI0 | GPI event according to active state setting / ADCIN1 high / low threshold exceeded caused event |

Note 1 Cleared from the host by writing back the read value.

Table 52: EVENT_D

| Register Address | Bit | Type Note 1 | Label | Description |
|------------------|-----|----------------|---------|---|
| 0x09 EVENT_D | 7 | R | E_GPI15 | GPI event according to active state setting |
| | 6 | R | E_GPI14 | GPI event according to active state setting/Event caused from host addressing HS 2-WIRE interface |
| | 5 | R | E_GPI13 | GPI event according to active state setting |
| | 4 | R | E_GPI12 | GPI event according to active state setting |
| | 3 | R | E_GPI11 | GPI event according to active state setting |
| | 2 | R | E_GPI10 | GPI/PWR1_EN event according to active state setting |

System PMIC for Mobile and Automotive Applications

| Register Address | Bit | Type Note 1 | Label | Description |
|------------------|-----|----------------|--------|--|
| | 1 | R | E_GPI9 | GPI/PWR_EN event according to active state setting |
| | 0 | R | E_GPI8 | GPI/SYS_EN event according to active state setting |

Note 1 Cleared from the host by writing back the read value.

The nIRQ line is released only when all events have been cleared from the host processor by writing the read value into all registers with an asserted event bit.

Table 53: IRQ_MASK_A

| Register Address | Bit | Type | Label | Description |
|--------------------|-----|------|-----------|---|
| 0x0A IRQ_MASK_A | 7:5 | R/W | Reserved | |
| | 4 | R/W | M_SEQ_RDY | Mask nIRQ from finishing power sequencing |
| | 3 | R/W | M_ADC_RDY | Mask ADC manual conversion result ready caused nIRQ |
| | 2:1 | R/W | Reserved | |
| | 0 | R/W | M_nONKEY | Mask nONKEY caused nIRQ |

Table 54: IRQ_MASK_B

| Register Address | Bit | Type | Label | Description |
|--------------------|-----|------|------------|--|
| 0x0B IRQ_MASK_B | 7 | R/W | M_VDD_WARN | Mask VDDFAULT_UPPER comparator triggered event |
| | 6 | R/W | M_VDD_MON | Mask V _{sys} caused nIRQ |
| | 5 | R/W | M_DVC_RDY | Mask DVC voltage ramping triggered event |
| | 4 | R/W | M_REG_UVOV | Mask events generated from regulator output voltage monitoring |
| | 3 | R/W | M_LDO_LIM | Mask LDO current limit exceeded caused nIRQ |
| | 2 | R/W | M_COMP1V2 | Mask 1.2 V comparator caused nIRQ |
| | 1 | R/W | M_TEMP | Mask junction over temp caused nIRQ |
| | 0 | R/W | M_WAKE | Mask companion charger caused event |

Table 55: IRQ_MASK_E

| Register Address | Bit | Type | Label | Description |
|--------------------|-----|------|--------|----------------------|
| 0x0C IRQ_MASK_E | 7 | R/W | M_GPI7 | Mask GPI caused nIRQ |
| | 6 | R/W | M_GPI6 | Mask GPI caused nIRQ |
| | 5 | R/W | M_GPI5 | Mask GPI caused nIRQ |
| | 4 | R/W | M_GPI4 | Mask GPI caused nIRQ |

System PMIC for Mobile and Automotive Applications

| Register Address | Bit | Type | Label | Description |
|------------------|-----|------|---------------|--|
| | 3 | R/W | M_GPI3 | Mask GPI caused nIRQ |
| | 2 | R/W | M_GPI2 | Mask GPI caused / ADCIN3 high / low threshold exceeded caused nIRQ |
| | 1 | R/W | M_GPI1 | Mask GPI caused / ADCIN2 high / low threshold exceeded caused nIRQ |
| | 0 | R/W | M_GPI0 | Mask GPI caused / ADCIN1 high / low threshold exceeded caused nIRQ |

Table 56: IRQ_MASK_F

| Register Address | Bit | Type | Label | Description |
|--------------------|-----|------|----------------|--------------------------------|
| 0x0D IRQ_MASK_F | 7 | R/W | M_GPI15 | Mask GPI caused nIRQ |
| | 6 | R/W | M_GPI14 | Mask GPI/HS 2-WIRE caused nIRQ |
| | 5 | R/W | M_GPI13 | Mask GPI caused nIRQ |
| | 4 | R/W | M_GPI12 | Mask GPI caused nIRQ |
| | 3 | R/W | M_GPI11 | Mask GPI caused nIRQ |
| | 2 | R/W | M_GPI10 | Mask GPI/PWR1_EN caused nIRQ |
| | 1 | R/W | M_GPI9 | Mask GPI/PWR_EN caused nIRQ |
| | 0 | R/W | M_GPI8 | Mask GPI/SYS_EN caused nIRQ |

Table 57: CONTROL_A

| Register Address | Bit | Type | Label | Description |
|------------------|-----|------|------------------|---|
| 0xE CONTROL_A | 7 | R/W | Reserved | |
| | 6 | R/W | M_POWER1_EN | Mask the update of POWER1_EN when writing to CONTROL_A |
| | 5 | R/W | M_POWER_EN | Mask the update of POWER_EN when writing to CONTROL_A |
| | 4 | R/W | M_SYSTEM_EN | Mask the update of SYSTEM_EN when writing to CONTROL_A |
| | 3 | R/W | STANDBY | Clearing SYSTEM_EN/releasing port SYS_EN press will 0: completely power down to Slot 0 (Hibernate) 1: stop powering down at pointer PART_DOWN (Standby) |
| | 2 | R/W | POWER1_EN | Target status of power domain POWER1: controlled from OTP/PM interface and port PWR1_EN |
| | 1 | R/W | POWER_EN | Target status of power domain POWER: controlled from OTP/PM interface and port PWR_EN |

System PMIC for Mobile and Automotive Applications

| Register Address | Bit | Type | Label | Description |
|------------------|-----|------|------------------|--|
| | 0 | R/W | SYSTEM_EN | Target status of power domain SYSTEM: controlled from OTP/PM interface and port SYS_EN |

Table 58: CONTROL_B

| Register Address | Bit | Type | Label | Description |
|------------------|-----|------|-----------------------|---|
| 0xF CONTROL_B | 7 | R/W | BUCK_SLOWSTART | Enables soft-start for buck converters (recommended for application instant-on with discharged battery and weak external supply) Note 1 |
| | 6:5 | R/W | Reserved | |
| | 4 | R/W | nONKEY_LOCK | 0: Half-current POWERDOWN mode 1: Wakeup from POWERDOWN mode requires the nONKEY signal being low for longer than selected in KEY_DELAY (automatically cleared during power-up sequence) |
| | 3 | R/W | nRES_MODE | 0: No assertion of nRESET for power down sequence 1: Assert nRESET before starting power down sequence (release after leaving POWERDOWN mode in case RESET_EVENT < '11') |
| | 2 | R/W | RES_BLINKING | Enables (time limited) VDD_START triggered GPO11/4/15 flashing in case of no connected external supply |
| | 1 | R/W | WATCHDOG_PD | 0: Discontinue Watchdog timer during POWERDOWN mode 1: Watchdog timer continues during POWERDOWN mode |
| | 0 | R/W | CHG_SEL | Port CHG_WAKE is connected to 0: Dialog charger WAKE port 1: Charger SAFE_OUT |

Note 1 Increases buck start-up time up to 3 ms.

Table 59: CONTROL_C

| Register Address | Bit | Type | Label | Description |
|-------------------|-----|------|-------------------|--|
| 0x10 CONTROL_C | 7 | R/W | DEF_SUPPLY | When asserted all supplies (except LDOCORE) are enabled/disabled from OTP default mode when entering sequencer Slot 0. |
| | 6:5 | R/W | SLEW_RATE | DVC slewing (bucks and LDOs) is executed at 00: 10 mV every 4.0 μs 01: 10 mV every 2.0 μs |

System PMIC for Mobile and Automotive Applications

| Register Address | Bit | Type | Label | Description |
|------------------|-----|------|-------------------|---|
| | | | | 10: 10 mV every 1.0 μs 11: 10 mV every 0.5 μ s |
| | 4 | R/W | OTPREAD_EN | 0: OTP read after POWERDOWN mode disabled 1: Power supplies are configured with OTP values when leaving POWERDOWN mode |
| | 3 | R/W | AUTO_BOOT | 0: Start-up of power sequencer after progressing from RESET mode requires a valid wakeup event 1: PMIC automatically starts power sequencer after progressing from RESET mode |
| | 2:0 | R/W | DEBOUNCING | GPI, nONKEY and nSHUTDOWN debounce time 000: no debounce time 001: 0.1 ms 010: 1.0 ms 011: 10.2 ms 100: 51.2 ms 101: 256 ms 110: 512 ms 111: 1024 ms |

Table 60: CONTROL_D

| Register Address | Bit | Type | Label | Description |
|-------------------|-----|------|------------------|---|
| 0x11 CONTROL_D | 7:6 | R/W | BLINK_DUR | GPO10/GPO11 flashing on-time 00: 10 ms 01: 20 ms 10: 40 ms 11: 20 ms double stroke (180 ms period) |
| | 5:3 | R/W | BLINK_FRQ | GPO11/4/15 flashing frequency 000: no blinking (GPO11/14/15 state selected via GPIOx_MODE) 001: every second 010: every two seconds 011: every four seconds 100: every 180 ms (flicker mode) 101: every two seconds enabled by VDD_START 110: every four seconds enabled by VDD_START 111: every 180 ms enabled by VDD_START Note 1 |
| | 2:0 | R/W | TWDSCALE | 000: Watchdog disabled 001: 1x scaling applied to t_{WD_MAX} period 010: 2x 011: 4x 100: 8x 101: 16x 110: 32x 111: 64x |

System PMIC for Mobile and Automotive Applications

Note 1 Blinking from OTP settings 001 to 100 continues as long as an active charger is connected to port CHG_WAKE. In the absence of a battery charger a time limited blinking can be enabled via RES_BLINKING.

Table 61: CONTROL_E

| Register Address | Bit | Type | Label | Description |
|-------------------|-----|------|------------|--|
| 0x12 CONTROL_E | 7 | R/W | V_LOCK | 0: Allows host writes into registers 0x81 to 0x120 1: Disables register 0x81 to 0x120 re-programming from host interfaces |
| | 6 | R/W | PM_FB3_PIN | 0: nVIB_BRAKE disabled 1: nVIB_BRAKE enabled. Feedback pin is used as an input signal to stop and start the vibration motor (active low nVIB_BRAKE) |
| | 5 | R/W | PM_FB2_PIN | 0: Feedback pin indicates the status of regulators being selected for voltage supervision (PWR_OK) 1: Feedback pin is used as KEEP_ACT signal for the Watchdog unit |
| | 4 | R/W | PM_FB1_PIN | 0: Feedback pin indicates the detection of a wakeup event (EXT_WAKEUP) 1: Feedback pin is used as an indicator, signaling via low level ongoing power mode transitions (power sequencer and DVC) (READY) |
| | 3 | R/W | ECO_MODE | When asserted DA9063L is armed for the pulsed mode when entering RESET |
| | 2:0 | R/W | Reserved | |

Table 62: CONTROL_F

| Register Address | Bit | Type | Label | Description |
|-------------------|-----|------|----------|--|
| 0x13 CONTROL_F | 7:3 | R/W | Reserved | |
| | 2 | R/W | WAKE_UP | If set to 1 PMU wakes up from POWERDOWN mode. The bit is cleared back to 0 automatically 16 sec after entering ACTIVE mode |
| | 1 | R/W | SHUTDOWN | If set to 1 the sequencer powers down to RESET mode. The bit is cleared back to 0 automatically when entering the RESET mode |
| | 0 | R/W | WATCHDOG | If set to 1 watchdog timer is reset. The bit is cleared back to 0 automatically. |

Table 63: PD_DIS

| Register Address | Bit | Type | Label | Description |
|------------------|-----|------|------------|--|
| 0x14 PD_DIS | 7 | R/W | PMCONT_DIS | 0: SYS_EN, PWR_EN, PWR1_EN enabled during power down 1: Auto-Disable of SYS_EN, PWR_EN and |

System PMIC for Mobile and Automotive Applications

| Register Address | Bit | Type | Label | Description |
|------------------|-----|------|-------------|---|
| | | | | PWR1_EN during POWERDOWN mode and force the detection hidden transition when re-enabling the control from ports |
| | 6:4 | | Reserved | |
| | 3 | R/W | HS2WIRE_DIS | 0: HS 2-WIRE not disabled during power down 1: Auto-disable of HS 2-WIRE interface during POWERDOWN mode |
| | 2 | R/W | Reserved | |
| | 1 | R/W | GPADC_PAUSE | 0: ADC measurements continue during power down as configured 1: Auto-PAUSE auto measurements on A0, A1, A2 and A3 and manual measurement during POWERDOWN mode; if no autonomous auto-measurements are required (V_{sys} from vibration motor driver) switch off the ADC completely |
| | 0 | R/W | GPI_DIS | 0: GPIO extender enabled during power down 1: Auto-disable of features configured as GPI pins during POWERDOWN mode and force the detection hidden transition when re-enabling the pin |

Note 1 When the related ID is configured to be $1 < PD_DIS_STEP \leq MAX_COUNT$ the value of the above controls define whether functions are switched on when entering POWERDOWN mode from POR or wait until ID PD_DIS_STEP is processed.

A.2.2 GPIO Control

Table 64: GPIO0-1

| Register Address | Bit | Type | Label | Description |
|------------------|-----|------|------------|---|
| 0x15 GPIO0-1 | 7 | R/W | GPIO1_WEN | 0: Passive to active transition triggers a wakeup 1: Wakeup suppressed |
| | 6 | R/W | GPIO1_TYPE | 0: GPI: active low GPO: supplied from VDD_IO1 1: GPI: active high GPO: supplied from VDD_IO2 |
| | 5:4 | R/W | GPIO1_PIN | PIN assigned to 00: ADCIN2/1.2 V comparator 01: GPI (optional regulator HW control) 10: GPO mode controlled (Open drain) 11: GPO mode controlled (Push-pull) |
| | 3 | R/W | GPIO0_WEN | 0: Passive to active transition triggers a wakeup 1: Wakeup suppressed |
| | 2 | R/W | GPIO0_TYPE | 0: GPI: active low GPO: supplied from VDD_IO1 |

System PMIC for Mobile and Automotive Applications

| Register Address | Bit | Type | Label | Description |
|------------------|-----|------|------------------|--|
| | | | | 1: GPI: active high GPO: supplied from VDD_IO2 |
| | 1:0 | R/W | GPIO0_PIN | PIN assigned to 00: ADCIN1 01: GPI 10: GPO mode controlled (Open drain) 11: GPO mode controlled (Push-pull) |

Table 65: GPIO2-3

| Register Address | Bit | Type | Label | Description |
|------------------|-----|------|-------------------|---|
| 0x16 GPIO2-3 | 7 | R/W | GPIO3_WEN | 0: Passive to active transition triggers a wakeup 1: Wakeup suppressed |
| | 6 | R/W | GPIO3_TYPE | 0: GPI: active low GPO: supplied from VDD_IO1 1: GPI: active high GPO: supplied from VDD_IO2 |
| | 5:4 | R/W | GPIO3_PIN | PIN assigned to 00: Reserved 01: GPI 10: GPO mode controlled (Open drain) 11: GPO mode controlled (Push-pull) |
| | 3 | R/W | GPIO2_WEN | 0: Passive to active transition triggers a wakeup 1: Wakeup suppressed |
| | 2 | R/W | GPIO2_TYPE | 0: GPI: active low GPO: supplied from VDD_IO1 1: GPI: active high GPO: supplied from VDD_IO2 |
| | 1:0 | R/W | GPIO2_PIN | PIN assigned to 00: ADCIN3 01: GPI (optional regulator HW control) 10: GPO Sequencer controlled (Push-pull) 11: GPO mode controlled (Push-pull) |

Table 66: GPIO4-5

| Register Address | Bit | Type | Label | Description |
|------------------|-----|------|-------------------|--|
| 0x17 GPIO4-5 | 7 | R/W | GPIO5_WEN | 0: Passive to active transition triggers a wakeup 1: Wakeup suppressed |
| | 6 | R/W | GPIO5_TYPE | 0: GPI: active low GPO: supplied from VDD_IO1 1: GPI: active high GPO: supplied from VDD_IO2 |
| | 5:4 | R/W | GPIO5_PIN | PIN assigned to 00: Reserved 01: GPI 10: GPO mode controlled (Open drain) 11: GPO mode controlled (Push-pull) |

System PMIC for Mobile and Automotive Applications

| Register Address | Bit | Type | Label | Description |
|------------------|-----|------|-------------------|--|
| | 3 | R/W | GPIO4_WEN | 0: Passive to active transition triggers a wakeup 1: Wakeup suppressed |
| | 2 | R/W | GPIO4_TYPE | 0: GPI: active low GPO: supplied from VDD_IO1 1: GPI: active high GPO: supplied from VDD_IO2 |
| | 1:0 | R/W | GPIO4_PIN | PIN assigned to 00: CORE_SWS 01: GPI 10: GPO mode controlled (Open drain) 11: GPO mode controlled (Push-pull) |

Table 67: GPIO6-7

| Register Address | Bit | Type | Label | Description |
|------------------|-----|------|-------------------|--|
| 0x18 GPIO6-7 | 7 | R/W | GPIO7_WEN | 0: Passive to active transition triggers a wakeup 1: Wakeup suppressed |
| | 6 | R/W | GPIO7_TYPE | 0: GPI: active low GPO: supplied from VDD_IO1 1: GPI: active high GPO: supplied from VDD_IO2 |
| | 5:4 | R/W | GPIO7_PIN | PIN assigned to 00: Reserved 01: GPI 10: GPO Sequencer controlled (Push-pull) 11: GPO mode controlled (Push-pull) |
| | 3 | R/W | GPIO6_WEN | 0: Passive to active transition triggers a wakeup 1: Wakeup suppressed |
| | 2 | R/W | GPIO6_TYPE | 0: GPI: active low GPO: supplied from VDD_IO1 1: GPI: active high GPO: supplied from VDD_IO2 |
| | 1:0 | R/W | GPIO6_PIN | PIN assigned to 00: PERI_SWS 01: GPI 10: GPO mode controlled (Open drain) 11: GPO mode controlled (Push-pull) |

Table 68: GPIO8-9

| Register Address | Bit | Type | Label | Description |
|------------------|-----|------|-------------------|--|
| 0x19 GPIO8-9 | 7 | R/W | GPIO9_WEN | 0: Passive to active transition triggers a wakeup 1: Wakeup suppressed |
| | 6 | R/W | GPIO9_TYPE | 0: GPI/PWR_EN: active low GPO: supplied from VDD_IO1 |

System PMIC for Mobile and Automotive Applications

| Register Address | Bit | Type | Label | Description |
|------------------|-----|------|-------------------|---|
| | | | | 1: GPI/PWR_EN: active high GPO: supplied from VDD_IO2 |
| | 5:4 | R/W | GPIO9_PIN | PIN and status register bit assigned to 00: GPI with PWR_EN 01: GPI 10: GPO Sequencer controlled (Push-pull) 11: GPO mode controlled (Push-pull) |
| | 3 | R/W | GPIO8_WEN | 0: Passive to active transition triggers a wakeup 1: Wakeup suppressed |
| | 2 | R/W | GPIO8_TYPE | 0: GPI/SYS_EN: active low GPO: supplied from external/VDD_IO1 1: GPI/SYS_EN: active high GPO: supplied from VDD_IO2 |
| | 1:0 | R/W | GPIO8_PIN | PIN and status register bit assigned to 00: GPI with SYS_EN 01: GPI 10: GPO Sequencer controlled (Push-pull) 11: GPO mode controlled (Push-pull) |

Table 69: GPIO10-11

| Register Address | Bit | Type | Label | Description |
|-------------------|-----|------|-------------|--|
| 0x1A GPIO10-11 | 7 | R/W | GPIO11_WEN | 0: Passive to active transition triggers a wakeup 1: Wakeup suppressed |
| | 6 | R/W | GPIO11_TYPE | 0: GPI: active low GPO: supplied from external/VDD_IO1 1: GPI: active high GPO: supplied from VDD_IO2 |
| | 5:4 | R/W | GPIO11_PIN | PIN assigned to 00: GPO (Open drain, with optional blinking) 01: GPI 10: GPO Sequencer controlled (Push-pull) 11: GPO mode controlled (Push-pull) |
| | 3 | R/W | GPIO10_WEN | 0: Passive to active transition triggers a wakeup 1: Wakeup suppressed |
| | 2 | R/W | GPIO10_TYPE | 0: GPI/PWR1_EN: active low GPO: supplied from external/VDD_IO1 1: GPI/PWR1_EN: active high GPO: supplied from VDD_IO2 |
| | 1:0 | R/W | GPIO10_PIN | PIN and status register bit assigned to 00: GPI with PWR1_EN 01: GPI 10: GPO (Open drain) 11: GPO mode controlled (Push-pull) |

System PMIC for Mobile and Automotive Applications

Table 70: GPIO12-13

| Register Address | Bit | Type | Label | Description |
|-------------------|-----|------|--------------------|---|
| 0x1B GPIO12-13 | 7 | R/W | GPIO13_WEN | 0: Passive to active transition triggers a wakeup 1: Wakeup suppressed |
| | 6 | R/W | GPIO13_TYPE | 0: GPI: active low GPO/GP_FB1: supplied from external/VDD_IO1 1: GPI: active high GPO/GP_FB1: supplied from VDD_IO2 |
| | 5:4 | R/W | GPIO13_PIN | PIN and status register bit assigned to 00: GPO controlled by state of GP_FB1 (EXT_WAKEUP/READY) (Push-pull) 01: GPI (optional regulator HW control) 10: GPO controlled by state of GP_FB1 (EXT_WAKEUP/READY) (Open drain) 11: GPO mode controlled (Push-pull) |
| | 3 | R/W | GPIO12_WEN | 0: Passive to active transition triggers a wakeup 1: Wakeup suppressed |
| | 2 | R/W | GPIO12_TYPE | 0: GPI: active low GPO/ nVDD_FAULT/V_{sys} monitor: supplied from VDD_IO1 1: GPI: active high GPO/DD_FAULT/V _{sys} monitor: supplied from VDD_IO2 |
| | 1:0 | R/W | GPIO12_PIN | PIN assigned to 00: nVDD_FAULT (Push-pull) 01: GPI 10: GPO controlled by the state of V _{sys} monitor (Push-pull) 11: GPO mode controlled (Push-pull) |

Table 71: GPIO14-15

| Register Address | Bit | Type | Label | Description |
|-------------------|-----|------|--------------------|--|
| 0x1C GPIO14-15 | 7 | R/W | GPIO15_WEN | 0: Passive to active transition triggers a wakeup 1: Wakeup suppressed |
| | 6 | R/W | GPIO15_TYPE | 0: GPI: active low GPO: supplied from external/VDD_IO1 1: GPI: active high GPO: supplied from VDD_IO2 |
| | 5:4 | R/W | GPIO15_PIN | PIN assigned to 00: GPO (Open drain, with optional blinking) 01: GPI 10: CLK (configured via GPIO14_PIN) 11: GPO mode controlled (Open drain) |
| | 3 | R/W | GPIO14_WEN | 0: Passive to active transition triggers a wakeup 1: Wakeup suppressed |

System PMIC for Mobile and Automotive Applications

| Register Address | Bit | Type | Label | Description |
|------------------|-----|------|--------------------|---|
| | 2 | R/W | GPIO14_TYPE | 0: GPI: active low GPO: supplied from external/VDD_IO1 DATA/CLK supplied from VDD_IO1 (Note 1) 1: GPI: active high GPO: supplied from VDD_IO2 DATA/CLK supplied from VDD_IO2 (Note 1) |
| | 1:0 | R/W | GPIO14_PIN | PIN assigned to 00: GPO(Open drain, with optional blinking) 01: GPI 10: DATA (assigns GPIO15_PIN to CLK) 11: GPO mode controlled (Push-pull) |

Note 1 When using as HS 2-WIRE interface input logic levels are derived from VDDCORE.

Table 72: GPIO_MODE0_7

| Register Address | Bit | Type | Label | Description |
|----------------------|-----|------|-------------------|---|
| 0x1D GPIO_MODE0_7 | 7 | R/W | GPIO7_MODE | 0: GPI: debouncing off GPO: Sets output to low level (active low for sequencer control) 1: GPI: debouncing on GPO: Sets output to high level (active high for sequencer control) |
| | 6 | R/W | GPIO6_MODE | 0: GPI: debouncing off GPO: Sets output to low level (active low for sequencer control) 1: GPI: debouncing on GPO: Sets output to high level (active high for sequencer control) |
| | 5 | R/W | GPIO5_MODE | 0: GPI: debouncing off GPO: Sets output to low level 1: GPI: debouncing on GPO: Sets output to high level |
| | 4 | R/W | GPIO4_MODE | 0: GPI: debouncing off GPO: Sets output to low level(active low for sequencer control) 1: GPI: debouncing on GPO: Sets output to high level (active high for sequencer control) |
| | 3 | R/W | GPIO3_MODE | 0: GPI: debouncing off GPO: Sets output to low level (active low for sequencer control) 1: GPI: debouncing on GPO: Sets output to high level (active high for sequencer control) |
| | 2 | R/W | GPIO2_MODE | 0: GPI: debouncing off GPO: Sets output to low level 1: GPI: debouncing on GPO: Sets output to high level |

System PMIC for Mobile and Automotive Applications

| Register Address | Bit | Type | Label | Description |
|------------------|-----|------|--------------------|--|
| | 1 | R/W | GPIO1_ MODE | 0: GPI: debouncing off GPO: Sets output to low level 1: GPI: debouncing on GPO: Sets output to high level |
| | 0 | R/W | GPIO0_ MODE | 0: GPI: debouncing off GPO: Sets output to low level 1: GPI: debouncing on GPO: Sets output to high level |

Table 73: GPIO_MODE8_15

| Register Address | Bit | Type | Label | Description |
|-----------------------|-----|------|---------------------|---|
| 0x1E GPIO_MODE8_15 | 7 | R/W | GPIO15_ MODE | 0: GPI: debouncing off GPO: Sets output to low level (active high for blinking) 1: GPI: debouncing on GPO: Sets output to high level (active low for blinking) |
| | 6 | R/W | GPIO14_ MODE | 0: GPI: debouncing off GPO: Sets output to low level (active high for blinking) 1: GPI:debouncing on GPO: Sets output to high level (active low for blinking) |
| | 5 | R/W | GPIO13_ MODE | 0: GPI: debouncing off GPO: Sets output to low level (active low for GP_FB1) 1: GPI: debouncing on GPO: Sets output to high level (active high for GP_FB1) |
| | 4 | R/W | GPIO12_ MODE | 0: GPI: debouncing off GPO: Sets output to low level (active low for nVDD_FAULT, V _{sys} monitor state) 1: GPI: debouncing on GPO: Sets output to high level (active high for nVDD_FAULT, V _{sys} monitor state) |
| | 3 | R/W | GPIO11_ MODE | 0: GPI: : debouncing off GPO: Sets output to low level (active high for blinking) 1: GPI: : debouncing on GPO: Sets output to high level (active low for blinking) |
| | 2 | R/W | GPIO10_ MODE | 0: GPI/PWR1_EN: debouncing off GPO: Sets output to low level 1: GPI/PWR1_EN: debouncing on GPO: Sets output to high level |
| | 1 | R/W | GPIO9_ MODE | 0: GPI/PWR_EN: debouncing off GPO: Sets output to low level (active low for sequencer control) 1: GPI/PWR_EN debouncing on GPO: Sets output to high level (active high for sequencer control) |

System PMIC for Mobile and Automotive Applications

| Register Address | Bit | Type | Label | Description |
|------------------|-----|------|-------------------|--|
| | 0 | R/W | GPIO8_MODE | 0: GPI/SYS_EN: debouncing off GPO: Sets output to low level 1: GPI/SYS_EN: debouncing on GPO: Sets output to high level |

Table 74: Reserved

| Register Address | Bit | Type | Label | Description |
|------------------|-----|------|----------|-------------|
| 0x1F | 7:0 | | Reserved | |

A.2.3 Regulator Control

Table 75: BCORE2_CONT

| Register Address | Bit | Type | Label | Description |
|-------------------------------|-----|------|--------------------|--|
| 0x20 BCORE2_CONT Note 1 | 7 | R/W | Reserved | |
| | 6:5 | R/W | VBCORE2_GPI | GPIO select target voltage VBCORE2_A on passive to active transition, selects target voltage VBCORE2_B on active to passive transition (ramping) 00: Not controlled by GPIO (sequencer control) 01: GPIO1 controlled 10: GPIO2 controlled 11: GPIO13 controlled |
| | 4 | R/W | Reserved | |
| | 3 | R/W | BCORE2_CONF | Sequencer target state of BCORE2_EN |
| | 2:1 | R/W | BCORE2_GPI | GPIO enables BUCKCORE2 on passive to active state transition, disables BUCKCORE2 on active to passive state transition 00: Not controlled by GPIO (sequencer control) 01: GPIO1 controlled 10: GPIO2 controlled 11: GPIO13 controlled |
| | 0 | R/W | BCORE2_EN | 0: BUCKCORE2 disabled 1: BUCKCORE2 enabled |

Note 1 Disabled in BUCKCORE dual-phase mode.

Table 76: BCORE1_CONT

| Register Address | Bit | Type | Label | Description |
|---------------------|-----|------|---------------------|---|
| 0x21 BCORE1_CONT | 7 | R/W | CORE_SW_CONF | Sequencer target state of CORE_SW_EN |
| | 6:5 | R/W | VBCORE1_GPI | GPIO select target voltage VBCORE1_A on passive to active transition, selects target voltage VBCORE1_B on active to passive transition (ramping) 00: Not controlled by GPIO (sequencer control) 01: GPIO1 controlled |

System PMIC for Mobile and Automotive Applications

| Register Address | Bit | Type | Label | Description |
|------------------|-----|------|--------------------|--|
| | | | | 10: GPIO2 controlled 11: GPIO13 controlled |
| | 4 | R/W | CORE_SW_EN | 0: CORE_SW opened 1: CORE_SW closed |
| | 3 | R/W | BCORE1_CONF | Sequencer target state of BCORE1_EN |
| | 2:1 | R/W | BCORE1_GPI | GPIO enables BUCKCORE1 on passive to active state transition, disables BUCKCORE1 on active to passive state transition 00: Not controlled by GPIO (sequencer control) 01: GPIO1 controlled 10: GPIO2 controlled 11: GPIO13 controlled |
| | 0 | R/W | BCORE1_EN | 0: BUCKCORE1 disabled 1: BUCKCORE1 enabled |

Table 77: BPRO_CONT

| Register Address | Bit | Type | Label | Description |
|-------------------|-----|------|------------------|--|
| 0x22 BPRO_CONT | 7 | R/W | Reserved | |
| | 6:5 | R/W | VBPRO_GPI | GPIO select target voltage VBPRO_A on passive to active transition, selects target voltage VBPRO_B on active to passive transition (ramping) 00: Not controlled by GPIO (sequencer control) 01: GPIO1 controlled 10: GPIO2 controlled 11: GPIO13 controlled |
| | 4 | R/W | Reserved | |
| | 3 | R/W | BPRO_CONF | Sequencer target state of BPRO_EN |
| | 2:1 | R/W | BPRO_GPI | GPIO enables BUCKPRO on passive to active state transition, disables BUCKPRO on active to passive state transition 00: Not controlled by GPIO (sequencer control) 01: GPIO1 controlled 10: GPIO2 controlled 11: GPIO13 controlled |
| | 0 | R/W | BPRO_EN | 0: BUCKPRO disabled 1: BUCKPRO enabled |

Table 78: BMEM_CONT

| Register Address | Bit | Type | Label | Description |
|-------------------|-----|------|------------------|--|
| 0x23 BMEM_CONT | 7 | R/W | Reserved | |
| | 6:5 | R/W | VBMEM_GPI | GPIO select target voltage VBMEM_A on passive to active transition, selects target voltage VBMEM_B on active to passive transition (ramping) |

System PMIC for Mobile and Automotive Applications

| Register Address | Bit | Type | Label | Description |
|------------------|-----|------|------------------|--|
| | | | | 00: Not controlled by GPIO (sequencer control) 01: GPIO1 controlled 10: GPIO2 controlled 11: GPIO13 controlled |
| | 4 | R/W | Reserved | |
| | 3 | R/W | BMEM_CONF | Sequencer target state of BMEM_EN in case of being a default supply) |
| | 2:1 | R/W | BMEM_GPI | GPIO enables BUCKMEM on passive to active state transition, disables BUCKMEM on active to passive state transition 00: Not controlled by GPIO (sequencer control) 01: GPIO1 controlled 10: GPIO2 controlled 11: GPIO13 controlled |
| | 0 | R/W | BMEM_EN | 0: BUCKMEM disabled 1: BUCKMEM enabled |

Table 79: BIO_CONT

| Register Address | Bit | Type | Label | Description |
|------------------|-----|------|-----------------|--|
| 0x24 BIO_CONT | 7 | R/W | Reserved | |
| | 6:5 | R/W | VBIO_GPI | GPIO select target voltage VBIO_A on passive to active transition, selects target voltage VBIO_B on active to passive transition (ramping) 00: Not controlled by GPIO (sequencer control) 01: GPIO1 controlled 10: GPIO2 controlled 11: GPIO13 controlled |
| | 4 | R/W | Reserved | |
| | 3 | R/W | BIO_CONF | Sequencer target state of BIO_EN |
| | 2:1 | R/W | BIO_GPI | GPIO enables BUCKIO on passive to active state transition, disables BUCKIO on active to passive state transition 00: Not controlled by GPIO (sequencer control) 01: GPIO1 controlled 10: GPIO2 controlled 11: GPIO13 controlled |
| | 0 | R/W | BIO_EN | 0: BUCKIO disabled 1: BUCKIO enabled |

Table 80: BPERI_CONT

| Register Address | Bit | Type | Label | Description |
|--------------------|-----|------|---------------------|---|
| 0x25 BPERI_CONT | 7 | R/W | PERI_SW_CONF | Sequencer target state of PERI_SW_EN |
| | 6:5 | R/W | VBPERI_GPI | GPIO select target voltage VBPERI_A on passive to active transition, selects target |

System PMIC for Mobile and Automotive Applications

| Register Address | Bit | Type | Label | Description |
|------------------|-----|------|-------------------|--|
| | | | | voltage VBPERI_B on active to passive transition (ramping) 00: Not controlled by GPIO (sequencer control) 01: GPIO1 controlled 10: GPIO2 controlled 11: GPIO13 controlled |
| | 4 | R/W | PERI_SW_EN | 0: PERI_SW opened 1: PERI_SW closed |
| | 3 | R/W | BPERI_CONF | Sequencer target state of BPERI_EN |
| | 2:1 | R/W | BPERI_GPI | GPIO enables BUCKPERI on passive to active state transition, disables BUCKPERI on active to passive state transition 00: Not controlled by GPIO (sequencer control) 01: GPIO1 controlled 10: GPIO2 controlled 11: GPIO13 controlled |
| | 0 | R/W | BPERI_EN | 0: BUCKPERI disabled 1: BUCKPERI enabled |

Table 81: Reserved

| Register Address | Bit | Type | Label | Description |
|------------------|-----|------|----------|-------------|
| 0x26, 0x27 | 7:0 | R/W | Reserved | |

Table 82: LDO3_CONT

| Register Address | Bit | Type | Label | Description |
|-------------------|-----|------|--------------------|--|
| 0x28 LDO3_CONT | 7 | R/W | LDO3_CONF | Sequencer target state of LDO3_EN |
| | 6:5 | R/W | VLDO3_GPI | GPIO select target voltage VLDO3_A on passive to active transition, selects target voltage VLDO3_B on active to passive transition (ramping) 00: Not controlled by GPIO (sequencer control) 01: GPIO1 controlled 10: GPIO2 controlled 11: GPIO13 controlled |
| | 4 | R/W | Reserved | |
| | 3 | R/W | LDO3_PD_DIS | 0: Enable pull-down resistor 1: No pull-down resistor in disabled mode |
| | 2:1 | R/W | LDO3_GPI | GPIO enables LDO3 on passive to active state transition, disables LDO3 on active to passive state transition 00: Not controlled by GPIO (sequencer control) 01: GPIO1 controlled 10: GPIO2 controlled 11: GPIO13 controlled |

System PMIC for Mobile and Automotive Applications

| Register Address | Bit | Type | Label | Description |
|------------------|-----|------|---------|--|
| | 0 | R/W | LDO3_EN | 0: LDO3 disabled 1: LDO3 enabled |

Table 83: Reserved

| Register Address | Bit | Type | Label | Description |
|------------------|-----|------|----------|-------------|
| 0x29 to 0x2B | 7:0 | R/W | Reserved | |

Table 84: LDO7_CONT

| Register Address | Bit | Type | Label | Description |
|-------------------|-----|------|--------------------|---|
| 0x2C LDO7_CONT | 7 | R/W | LDO7_CONF | Sequencer target state of LDO7_EN |
| | 6:5 | R/W | VLDO7_GPI | GPIO select target voltage VLDO7_A on passive to active transition, selects target voltage VLDO7_B on active to passive transition (immediate voltage change) 00: Not controlled by GPIO (sequencer control) 01: GPIO1 controlled 10: GPIO2 controlled 11: GPIO13 controlled |
| | 4 | R/W | VLDO7_SEL | LDO7 voltage is selected from (immediate change): 0: VLDO7_A 1: VLDO7_B |
| | 3 | R/W | LDO7_PD_DIS | 0: Enable pull-down resistor 1: No pull-down resistor in disabled mode |
| | 2:1 | R/W | LDO7_GPI | GPIO enables LDO7 on passive to active state transition, disables LDO7 on active to passive state transition 00: Not controlled by GPIO (sequencer control) 01: GPIO1 controlled 10: GPIO2 controlled 11: GPIO13 controlled |
| | 0 | R/W | LDO7_EN | 0: LDO7 disabled 1: LDO7 enabled |

Table 85: LDO8_CONT

| Register Address | Bit | Type | Label | Description |
|-------------------|-----|------|------------------|---|
| 0x2D LDO8_CONT | 7 | R/W | LDO8_CONF | Sequencer target state of LDO8_EN |
| | 6:5 | R/W | VLDO8_GPI | GPIO select target voltage VLDO8_A on passive to active transition, selects target voltage VLDO8_B on active to passive transition (immediate voltage change) 00: Not controlled by GPIO (sequencer control) 01: GPIO1 controlled 10: GPIO2 controlled 11: GPIO13 controlled |

System PMIC for Mobile and Automotive Applications

| Register Address | Bit | Type | Label | Description |
|------------------|-----|------|-------------|--|
| | 4 | R/W | VLDO8_SEL | LDO8 voltage is selected from (immediate change): 0: VLDO8_A 1: VLDO8_B |
| | 3 | R/W | LDO8_PD_DIS | 0: Enable pull-down resistor 1: No pull-down resistor in disabled mode |
| | 2:1 | R/W | LDO8_GPI | GPIO enables LDO8 on passive to active state transition, disables LDO8 on active to passive state transition 00: Not controlled by GPIO (sequencer control) 01: GPIO1 controlled 10: GPIO2 controlled 11: GPIO13 controlled |
| | 0 | R/W | LDO8_EN | 0: LDO8 disabled 1: LDO8 enabled |

Table 86: LDO9_CONT

| Register Address | Bit | Type | Label | Description |
|-------------------|-----|------|-------------|---|
| 0x2E LDO9_CONT | 7 | R/W | LDO9_CONF | Sequencer target state of LDO9_EN |
| | 6:5 | R/W | VLDO9_GPI | GPIO select target voltage VLDO9_A on passive to active transition, selects target voltage VLDO9_B on active to passive transition (immediate voltage change) 00: Not controlled by GPIO (sequencer control) 01: GPIO1 controlled 10: GPIO2 controlled 11: GPIO13 controlled |
| | 4 | R/W | VLDO9_SEL | LDO9 voltage is selected from (immediate change): 0: VLDO9_A 1: VLDO9_B |
| | 3 | R/W | LDO9_PD_DIS | 0: Enable pull-down resistor 1: No pull-down resistor in disabled mode |
| | 2:1 | R/W | LDO9_GPI | GPIO enables LDO9 on passive to active state transition, disables LDO9 on active to passive state transition 00: Not controlled by GPIO (sequencer control) 01: GPIO1 controlled 10: GPIO2 controlled 11: GPIO13 controlled |
| | 0 | R/W | LDO9_EN | 0: LDO9 disabled 1: LDO9 enabled |

Table 87: Reserved

| Register Address | Bit | Type | Label | Description |
|------------------|-----|------|----------|-------------|
| 0x2F | 7:0 | R/W | Reserved | |

System PMIC for Mobile and Automotive Applications

Table 88: LDO11_CONT

| Register Address | Bit | Type | Label | Description |
|--------------------|-----|-----------------|--|---|
| 0x30 LDO11_CONT | 7 | R/W | LDO11_CONF | Sequencer target state of LDO11_EN |
| | 6:5 | R/W | VLDO11_GPI | GPIO select target voltage VLDO11_A on passive to active transition, selects target voltage VLDO11_B on active to passive transition (immediate voltage change) 00: Not controlled by GPIO (sequencer control) 01: GPIO1 controlled 10: GPIO2 controlled 11: GPIO13 controlled |
| | 4 | R/W | VLDO11_SEL | LDO11 voltage is selected from (immediate change): 0: VLDO11_A 1: VLDO11_B |
| | 3 | R/W | LDO11_PD_DIS | 0: Enable pull-down resistor 1: No pull-down resistor in disabled mode |
| | 2:1 | R/W | LDO11_GPI | GPIO enables LDO11 on passive to active state transition, disables LDO11 on active to passive state transition 00: Not controlled by GPIO (sequencer control) 01: GPIO1 controlled 10: GPIO2 controlled 11: GPIO13 controlled |
| 0 | R/W | LDO11_EN | 0: LDO11 disabled 1: LDO11 enabled | |

Table 89: VIB

| Register Address | Bit | Type | Label | Description |
|------------------|-----|------|-----------------|--|
| 0x31 VIB | 7:6 | R/W | Reserved | |
| | 5:0 | R/W | VIB_SET | 000000: OFF-BREAK, NMOS on, PMOS off 000001: 47.55 mV 000010: 95.1 mV ... Average output level set in a range of 0 to 3 V in steps of 3 V/63 111111: 3.0 V |

Table 90: DVC_1

| Register Address | Bit | Type | Label | Description |
|------------------|-----|------|-----------|---|
| 0x32 DVC_1 | 7 | R/W | VLDO3_SEL | LDO3 voltage is selected from (ramping): 0: VLDO3_A 1: VLDO3_B |
| | 6:5 | R/W | Reserved | |

System PMIC for Mobile and Automotive Applications

| Register Address | Bit | Type | Label | Description |
|------------------|-----|------|-------------|--|
| | 4 | R/W | VBPERI_SEL | BUCKPERI voltage is selected from (ramping): 0: VBPERI_A 1: VBPERI_B |
| | 3 | R/W | VBMEM_SEL | BUCKMEM voltage is selected from (ramping): 0: VBMEM_A 1: VBMEM_B |
| | 2 | R/W | VBPRO_SEL | BUCKPRO voltage is selected from (ramping): 0: VBPRO_A 1: VBPRO_B |
| | 1 | R/W | VBCORE2_SEL | BUCKCORE2 voltage is selected from (ramping): 0: VBCORE2_A 1: VBCORE2_B |
| | 0 | R/W | VBCORE1_SEL | BUCKCORE1 voltage is selected from (ramping): 0: VBCORE1_A 1: VBCORE1_B |

Table 91: DVC_2

| Register Address | Bit | Type | Label | Description |
|------------------|-----|------|----------|---|
| 0x33 DVC_2 | 7:1 | R/W | Reserved | |
| | 0 | R/W | VBIO_SEL | BUCKIO voltage is selected from (ramping): 0: VBIO_A 1: VBIO_B |

System PMIC for Mobile and Automotive Applications

A.2.4 GPADC

Table 92: ADC_MAN

| Register Address | Bit | Type | Label | Description |
|------------------|-----|------|----------|---|
| 0x34 ADC_MAN | 7:6 | R/W | Reserved | |
| | 5 | R/W | ADC_MODE | 0: Measurement sequence interval 10 ms (economy mode) 1: Measurement sequence interval 1 ms |
| | 4 | R/W | ADC_MAN | Perform manual conversion. Bit is reset to 0 when conversion is complete. |
| | 3:0 | R/W | ADC_MUX | Manual measurement selects: 0000: VSYS port 0001: ADCIN1 0010: ADCIN2 0011: ADCIN3 0100: internal T-Sense 0101: reserved 0110: reserved 0111: reserved 1000: Group 1 regulators voltage 1001: Group 2 regulators voltage 1010: Group 3 regulators voltage > 1010: reserved |

Table 93: ADC_CONT

| Register Address | Bit | Type | Label | Description |
|------------------|-----|------|--------------|---|
| 0x35 ADC_CONT | 7 | R/W | COMP1V2_EN | 0: Disable 1.2 V comparator at ADCIN2 1: Enable 1.2 V comparator |
| | 6 | R/W | AD3_ISRC_EN | 0: Disable ADCIN3 current source 1: Enable ADCIN3 current source |
| | 5 | R/W | AD2_ISRC_EN | 0: Disable ADCIN2 current source 1: Enable ADCIN2 current source |
| | 4 | R/W | AD1_ISRC_EN | 0: Disable ADCIN1 current source 1: Enable ADCIN1 current source |
| | 3 | R/W | AUTO_AD3_EN | 0: ADCIN3 auto-measurements disabled 1: ADCIN3 auto-measurements enabled |
| | 2 | R/W | AUTO_AD2_EN | 0: ADCIN2 auto-measurements disabled 1: ADCIN2 auto-measurements enabled |
| | 1 | R/W | AUTO_AD1_EN | 0: ADCIN1 auto-measurements disabled 1: ADCIN1 auto-measurements enabled |
| | 0 | R/W | AUTO_VSYS_EN | 0: VSYS auto-measurements disabled when charger/vibration motor driver is off 1: VSYS auto-measurements enabled |

Table 94: VSYS_MON

| Register Address | Bit | Type | Label | Description |
|------------------|-----|------|----------|-------------------------------------|
| 0x36 VSYS_MON | 7:0 | R/W | VSYS_MON | VSYS_MON threshold setting (8-bit). |

System PMIC for Mobile and Automotive Applications

| | | | | |
|--|--|--|--|--|
| | | | | 00000000 corresponds to 2.5 V 11111111 corresponds to 5.5 V |
|--|--|--|--|--|

A.2.5 ADC Results

Table 95: ADC_RES_L

| Register Address | Bit | Type | Label | Description |
|-------------------|-----|------|-------------|--|
| 0x37 ADC_RES_L | 7:6 | R | ADC_RES_LSB | 10-bit manual conversion result (2 LSBs) |
| | 5:0 | R | Reserved | |

Table 96: ADC_RES_H

| Register Address | Bit | Type | Label | Description |
|-------------------|-----|------|-------------|--|
| 0x38 ADC_RES_H | 7:0 | R | ADC_RES_MSB | 10-bit manual conversion result (8 MSBs) |

Table 97: VSYS_RES

| Register Address | Bit | Type | Label | Description |
|------------------|-----|------|----------|---|
| 0x39 VSYS_RES | 7:0 | R | VSYS_RES | 0x00 – 0xFF: Auto VSYS conversion result (A0) 0x00 corresponds to 2.5 V 0xFF corresponds to 5.5 V |

Table 98: ADCIN1_RES

| Register Address | Bit | Type | Label | Description |
|--------------------|-----|------|------------|--|
| 0x3A ADCIN1_RES | 7:0 | R | ADCIN1_RES | 0x00 – 0xFF: Auto ADC ADCIN1 conversion result |

Table 99: ADCIN2_RES

| Register Address | Bit | Type | Label | Description |
|--------------------|-----|------|------------|--|
| 0x3B ADCIN2_RES | 7:0 | R | ADCIN2_RES | 0x00 – 0xFF: Auto ADC ADCIN2 conversion result |

Table 100: ADCIN3_RES

| Register Address | Bit | Type | Label | Description |
|--------------------|-----|------|------------|--|
| 0x3C ADCIN3_RES | 7:0 | R | ADCIN3_RES | 0x00 – 0xFF: Auto ADC ADCIN3 conversion result |

System PMIC for Mobile and Automotive Applications

Table 101: MON_A8_RES

| Register Address | Bit | Type | Label | Description |
|--------------------|-----|------|------------|--|
| 0x3D MON_A8_RES | 7:0 | R | MON_A8_RES | 0x00 – 0xFF: Regulator output voltage monitor 1 (A8) conversion result 0x00 corresponds to 0.0 V 0xFF corresponds to 5.0 V |

Table 102: MON_A9_RES

| Register Address | Bit | Type | Label | Description |
|--------------------|-----|------|------------|--|
| 0x3E MON_A9_RES | 7:0 | R | MON_A9_RES | 0x00 – 0xFF: Regulator output voltage monitor 2 (A9) conversion result 0x00 corresponds to 0.0 V 0xFF corresponds to 5.0 V |

Table 103: MON_A10_RES

| Register Address | Bit | Type | Label | Description |
|---------------------|-----|------|-------------|---|
| 0x3F MON_A10_RES | 7:0 | R | MON_A10_RES | 0x00 – 0xFF: Regulator output voltage monitor 3 (A10) conversion result 0x00 corresponds to 0.0 V 0xFF corresponds to 5.0 V |

Table 104: Reserved

| Register Address | Bit | Type | Label | Description |
|------------------|-----|------|----------|-------------|
| 0x40 to 0x4F | 7:0 | | Reserved | |

Table 105: Copmic_S to Copmic_E

| Register Address | Bit | Type | Label | Description |
|------------------|-----|------|----------|----------------------|
| 0x50 CoPMIC_S | 7:0 | R | Reserved | Reserved for Co-PMIC |
| 0x67 CoPMIC_E | 7:0 | R | Reserved | Reserved for Co-PMIC |

Table 106: CHG_Co_S to CHG_Co_E

| Register Address | Bit | Type | Label | Description |
|------------------|-----|------|----------|--------------------------------|
| 0x68 CHG_Co_S | 7:0 | R | Reserved | Reserved for companion charger |
| 0x7F CHG_Co_E | 7:0 | R | Reserved | Reserved for companion charger |

System PMIC for Mobile and Automotive Applications

A.3 Register Page 1

Table 107: PAGE_CON

| Register Address | Bit | Type | Label | Description |
|------------------|-----|------|------------|---|
| 0x80 PAGE_CON | 7 | RW | REVERT | See register 0x00, Table 43 |
| | 6 | RW | WRITE_MODE | |
| | 5:3 | RW | Reserved | |
| | 2:0 | RW | REG_PAGE | |

A.3.1 Power Sequencer

Table 108: SEQ

| Register Address | Bit | Type | Label | Description |
|------------------|-----|------|---------------|--|
| 0x81 SEQ | 7:4 | R/W | NXT_SEQ_START | Start time slot for first sequencing after being modified via register write |
| | 3:0 | R | SEQ_POINTER | Actual pointer position (time slot) of power sequencer |

System PMIC for Mobile and Automotive Applications

Table 109: SEQ_TIMER

| Register Address | Bit | Type | Label | Description |
|-------------------|-----|------|------------------|--|
| 0x82 SEQ_TIMER | 7:4 | R/W | SEQ_DUMMY | 0000: 32 μ s 0001: 64 μ s 0010: 96 μ s 0011: 128 μ s 0100: 160 μ s 0101: 192 μ s 0110: 224 μ s 0111: 256 μ s 1000: 288 μ s 1001: 384 μ s 1010: 448 μ s 1011: 512 μ s 1100: 1.024 ms 1101: 2.048 ms 1110: 4.096 ms 1111: 8.192 ms |
| | 3:0 | R/W | SEQ_TIME | 0000: 32 μ s 0001: 64 μ s 0010: 96 μ s 0011: 128 μ s 0100: 160 μ s 0101: 192 μ s 0110: 224 μ s 0111: 256 μ s 1000: 288 μ s 1001: 384 μ s 1010: 448 μ s 1011: 512 μ s 1100: 1.024 ms 1101: 2.048 ms 1110: 4.096 ms 1111: 8.192 ms |

Table 110: Reserved

| Register Address | Bit | Type | Label | Description |
|------------------|-----|------|----------|-------------|
| 0x83 | 7:0 | R/W | Reserved | |

Table 111: ID_4_3

| Register Address | Bit | Type | Label | Description |
|------------------|-----|------|------------------|--|
| 0x84 ID_4_3 | 7:4 | R/W | Reserved | |
| | 3:0 | R/W | LDO3_STEP | Power sequencer time slot for LDO3 control |

Table 112: Reserved

| Register Address | Bit | Type | Label | Description |
|------------------|-----|------|----------|-------------|
| 0x85 | 7:0 | | Reserved | |

System PMIC for Mobile and Automotive Applications

Table 113: ID_8_7

| Register Address | Bit | Type | Label | Description |
|------------------|-----|------|------------------|--|
| 0x86 ID_8_7 | 7:4 | R/W | LDO8_STEP | Power sequencer time slot for LDO8 control |
| | 3:0 | R/W | LDO7_STEP | Power sequencer time slot for LDO7 control |

Table 114: ID_10_9

| Register Address | Bit | Type | Label | Description |
|------------------|-----|------|------------------|--|
| 0x87 ID_10_9 | 7:4 | R/W | Reserved | |
| | 3:0 | R/W | LDO9_STEP | Power sequencer time slot for LDO9 control |

Table 115: ID_12_11

| Register Address | Bit | Type | Label | Description |
|------------------|-----|------|--------------------|---|
| 0x88 ID_12_11 | 7:4 | R/W | PD_DIS_STEP | Power sequencer time slot for control of blocks to be disabled/paused during POWERDOWN mode |
| | 3:0 | R/W | LDO11_STEP | Power sequencer time slot for LDO11 control |

Table 116: ID_14_13

| Register Address | Bit | Type | Label | Description |
|------------------|-----|------|-----------------------|---|
| 0x89 ID_14_13 | 7:4 | R/W | BUCKCORE2_STEP | Power sequencer time slot for control of BUCKCORE2 (disabled in BUCKCORE dual phase mode) |
| | 3:0 | R/W | BUCKCORE1_STEP | Power sequencer time slot for control of BUCKCORE1 |

Table 117: ID_16_15

| Register Address | Bit | Type | Label | Description |
|------------------|-----|------|---------------------|--|
| 0x8A ID_16_15 | 7:4 | R/W | BUCK_IO_STEP | Power sequencer time slot for control of BUCKPRO |
| | 3:0 | R/W | BUCKPRO_STEP | Power sequencer time slot for control of BUCKPRO |

Table 118: ID_18_17

| Register Address | Bit | Type | Label | Description |
|------------------|-----|------|----------------------|---|
| 0x8B ID_18_17 | 7:4 | R/W | BUCKPERI_STEP | Power sequencer time slot for control of BUCKPERI |
| | 3:0 | R/W | BUCKMEM_STEP | Power sequencer time slot for control of BUCKMEM |

System PMIC for Mobile and Automotive Applications

Table 119: Reserved

| Register Address | Bit | Type | Label | Description |
|------------------|-----|------|----------|-------------|
| 0x8C | 7:0 | R/W | Reserved | |

Table 120: ID_22_21

| Register Address | Bit | Type | Label | Description |
|------------------|-----|------|----------------------|--|
| 0x8D ID_22_21 | 7:4 | R/W | GP_FALL1_STEP | Power sequencer time slot for falling edge control of GPO2 |
| | 3:0 | R/W | GP_RISE1_STEP | Power sequencer time slot for rising edge control of GPO2 |

Table 121: ID_24_23

| Register Address | Bit | Type | Label | Description |
|------------------|-----|------|----------------------|--|
| 0x8E ID_24_23 | 7:4 | R/W | GP_FALL2_STEP | Power sequencer time slot for falling edge control of GPO7 |
| | 3:0 | R/W | GP_RISE2_STEP | Power sequencer time slot for rising edge control of GPO7 |

Table 122: ID_26_25

| Register Address | Bit | Type | Label | Description |
|------------------|-----|------|----------------------|--|
| 0x8F ID_26_25 | 7:4 | R/W | GP_FALL3_STEP | Power sequencer time slot for falling edge control of GPO8 |
| | 3:0 | R/W | GP_RISE3_STEP | Power sequencer time slot for rising edge control of GPO8 |

Table 123: ID_28_27

| Register Address | Bit | Type | Label | Description |
|------------------|-----|------|----------------------|--|
| 0x90 ID_28_27 | 7:4 | R/W | GP_FALL4_STEP | Power sequencer time slot for falling edge control of GPO9 |
| | 3:0 | R/W | GP_RISE4_STEP | Power sequencer time slot for rising edge control of GPO9 |

Table 124: ID_30_29

| Register Address | Bit | Type | Label | Description |
|------------------|-----|------|----------------------|---|
| 0x91 ID_30_29 | 7:4 | R/W | GP_FALL5_STEP | Power sequencer time slot for falling edge control of GPO11 |
| | 3:0 | R/W | GP_RISE5_STEP | Power sequencer time slot for rising edge control of GPO11 |

System PMIC for Mobile and Automotive Applications

Table 125: ID_32_31

| Register Address | Bit | Type | Label | Description |
|------------------|-----|------|------------------|--|
| 0x92 ID_32_31 | 7:4 | R/W | Reserved | |
| | 3:0 | R/W | WAIT_STEP | Power sequencer time slot that gates the progress with state of GPIO10 (or used a dedicated delay timer) |

Table 126: Reserved

| Register Address | Bit | Type | Label | Description |
|------------------|-----|------|-----------------|-------------|
| 0x93, 0x94 | 7:0 | R/W | Reserved | |

Table 127: SEQ_A

| Register Address | Bit | Type | Label | Description |
|------------------|-----|------|-------------------|---|
| 0x95 SEQ_A | 7:4 | R/W | POWER_END | OTP pointer to last supply of domain POWER |
| | 3:0 | R/W | SYSTEM_END | OTP pointer to last supply of domain SYSTEM |

Table 128: SEQ_B

| Register Address | Bit | Type | Label | Description |
|------------------|-----|------|------------------|---|
| 0x96 SEQ_B | 7:4 | R/W | PART_DOWN | OTP pointer for partial POWERDOWN mode |
| | 3:0 | R/W | MAX_COUNT | OTP pointer to last supply of domain POWER1 |

Table 129: WAIT

| Register Address | Bit | Type | Label | Description |
|------------------|-----|------|------------------|---|
| 0x97 WAIT | 7:6 | R/W | WAIT_DIR | 00: No wait during power sequencing 01: Wait during power-up sequence 10:: Wait during power-down sequence 11: Wait during power-up and power-down sequence |
| | 5 | R/W | TIME_OUT | 0: No time limit 1: 500 ms time out for waiting GPIO10 to get active |
| | 4 | R/W | WAIT_MODE | 0: Wait for GPIO10 to be active 1: Timer mode (start timer and wait for expire) |

System PMIC for Mobile and Automotive Applications

| Register Address | Bit | Type | Label | Description |
|------------------|-----|------|------------------|--|
| | 3:0 | R/W | WAIT_TIME | 0000: 0.0 μ s 0001: 512 μ s 0010: 1.0 ms 0011: 2.0 ms 0100: 4.1 ms 0101: 8.2 ms 0110: 16.4 ms 0111: 32.8 ms 1000: 65.5 ms 1001: 128 ms 1010: 256 ms 1011: 512 ms 1100: 1.0 s 1101: 2.1 s 1110: 4.2 s 1111: 8.4 s |

Table 130: Reserved

| Register Address | Bit | Type | Label | Description |
|------------------|-----|------|----------|-------------|
| 0x98 | 7:0 | R/W | Reserved | |

Table 131: RESET

| Register Address | Bit | Type | Label | Description |
|------------------|-----|------|--------------------|---|
| 0x99 RESET | 7:6 | R/W | RESET_EVENT | RESET timer started by 00: EXT_WAKEUP 01: SYS_UP 10: PWR_UP 11: leaving PMIC RESET state (do not use in combination with nRES_MODE = 1) |
| | 5:0 | R/W | RESET_TIMER | 000000: 0.000 ms 000001: 1.024 ms 000010: 2.048 ms 000011: 3.072 ms 000100: 4.096 ms 000101: 5.120 ms 011110: 30.720 ms 011111: 31.744 ms 100000: 32.768 ms 100001: 65.536 ms 100010: 98.304 ms 111101: 983.040 ms 111110: 1015.808 ms 111111: 1048.576 ms |

System PMIC for Mobile and Automotive Applications

A.3.2 Regulator Settings

Table 132: BUCK_ILIM_A

| Register Address | Bit | Type | Label | Description |
|---------------------|-----|------|------------------|---|
| 0x9A BUCK_ILIM_A | 7:4 | R/W | BMEM_ILIM | BUCKMEM current limit (all limits x2 in MERGE mode) 0000:1500 mA 0001:1600 mA 0010:1700 mA 0011:1800 mA 0100:1900 mA 0101:2000 mA 0110:2100 mA 0111:2200 mA 1000:2300 mA 1001:2400 mA 1010:2500 mA 1011:2600 mA 1100:2700 mA 1101:2800 mA 1110:2900 mA 1111:3000 mA |
| | 3:0 | R/W | BIO_ILIM | BUCKIO current limit 0000:1500 mA 0001:1600 mA 0010:1700 mA 0011:1800 mA 0100:1900 mA 0101:2000 mA 0110:2100 mA 0111:2200 mA 1000:2300 mA 1001:2400 mA 1010:2500 mA 1011:2600 mA 1100:2700 mA 1101:2800 mA 1110:2900 mA 1111:3000 mA |

Table 133: BUCK_ILIM_B

| Register Address | Bit | Type | Label | Description |
|---------------------|-----|------|-------------------|--|
| 0x9B BUCK_ILIM_B | 7:4 | R/W | BPERI_ILIM | BUCKPERI current limit 0000:1500 mA 0001:1600 mA 0010:1700 mA 0011:1800 mA 0100:1900 mA 0101:2000 mA 0110:2100 mA 0111:2200 mA 1000:2300 mA 1001:2400 mA 1010:2500 mA 1011:2600 mA 1100:2700 mA 1101:2800 mA |

System PMIC for Mobile and Automotive Applications

| Register Address | Bit | Type | Label | Description |
|------------------|-----|------|------------------|---|
| | | | | 1110:2900 mA 1111:3000 mA |
| | 3:0 | R/W | BPRO_ILIM | BUCKPRO current limit (all limits x2 in full-current mode) 0000:500 mA 0001:600 mA 0010:700 mA 0011:800 mA 0100:900 mA 0101:1000 mA 0110:1100 mA 0111:1200 mA 1000:1300 mA 1001:1400 mA 1010:1500 mA 1011:1600 mA 1100:1700 mA 1101:1800 mA 1110:1900 mA 1111:2000 mA |

Table 134: BUCK_ILIM_C

| Register Address | Bit | Type | Label | Description |
|---------------------|-----|------|--------------------|---|
| 0x9C BUCK_ILIM_C | 7:4 | R/W | BCORE2_ILIM | BUCKCORE2 current limit (all limits x2 in full-current mode) 0000:500 mA 0001:600 mA 0010:700 mA 0011:800 mA 0100:900 mA 0101:1000 mA 0110:1100 mA 0111:1200 mA 1000:1300 mA 1001:1400 mA 1010:1500 mA 1011:1600 mA 1100:1700 mA 1101:1800 mA 1110:1900 mA 1111:2000 mA |

System PMIC for Mobile and Automotive Applications

| Register Address | Bit | Type | Label | Description |
|------------------|-----|------|--------------------|---|
| | 3:0 | R/W | BCORE1_ILIM | BUCKCORE1 current limit (all limits x2 in full-current mode) 0000:500 mA 0001:600 mA 0010:700 mA 0011:800 mA 0100:900 mA 0101:1000 mA 0110:1100 mA 0111:1200 mA 1000:1300 mA 1001:1400 mA 1010:1500 mA 1011:1600 mA 1100:1700 mA 1101:1800 mA 1110:1900 mA 1111:2000 mA |

Table 135: BCORE2_CONF

| Register Address | Bit | Type | Label | Description |
|---------------------|-----|------|----------------------|--|
| 0x9D BCORE2_CONF | 7:6 | R/W | BCORE2_MODE | 00: Sleep/Synchronous mode controlled via voltage A and B registers 01: BUCKCORE2 always operates in Sleep mode 10: BUCKCORE2 always operates in Synchronous mode 11: BUCKCORE2 operates in Automatic mode |
| | 5 | R/W | BCORE2_PD_DIS | 0: Enable pull-down resistor (automatically disabled in dual-phase mode) 1: No pull-down resistor in disabled mode |
| | 4:3 | | Reserved | |
| | 2:0 | R/W | BCORE2_FB | BUCKCORE2 feedback signal is created out of: xx1: VBUCKCORE2 x1x: CORE_SWS 1xx: PERI_SWS Each switch connected to the output of the buck may be selected; setting 0b000 is invalid |

Table 136: BCORE1_CONF

| Register Address | Bit | Type | Label | Description |
|---------------------|-----|------|--------------------|--|
| 0x9E BCORE1_CONF | 7:6 | R/W | BCORE1_MODE | 00: Sleep/Synchronous mode controlled via voltage A and B registers 01: BUCKCORE1 always operates in Sleep mode 10: BUCKCORE1 always operates in Synchronous mode 11: BUCKCORE1 operates in Automatic mode |

System PMIC for Mobile and Automotive Applications

| Register Address | Bit | Type | Label | Description |
|------------------|-----|------|----------------------|---|
| | 5 | R/W | BCORE1_PD_DIS | 0: Enable pull-down resistor 1: No pull-down resistor in disabled mode |
| | 4:3 | | Reserved | |
| | 2:0 | R/W | BCORE1_FB | BUCKCORE feedback signal is created out of: 000: BCORE_MERGE= 0: VBUCKCORE1 BCORE_MERGE= 1: Differential remote sensing via VBUCKCORE1 – VBUCKCORE2 and output capacitor voltage sense via port CORE_SWS or GP_FB_2 xx1: VBUCKCORE1 x1x: CORE_SWS 1xx: PERI_SWS Each switch connected to the output of the buck may be selected; setting 0b000 disables sense voltage mixer for BUCKCORE |

Table 137: BPRO_CONF

| Register Address | Bit | Type | Label | Description |
|-------------------|-----|------|---------------------|---|
| 0x9F BPRO_CONF | 7:6 | R/W | BPRO_MODE | 00: Sleep/Synchronous mode controlled via voltage A and B registers 10: BUCKPRO always operates in Sleep mode 10: BUCKPRO always operates in Synchronous 11: BUCKPRO operates in Automatic mode |
| | 5 | R/W | BPRO_PD_DIS | 0: Enable pull-down resistor 1: No pull-down resistor in disabled mode |
| | 4 | R/W | BPRO_VTT_EN | 0: Buck voltage mode 1: VTT mode, buck target voltage tracks 50% of VDDQ sense port (requires BPRO_VTTR_EN to be asserted as well) |
| | 3 | R/W | BPRO_VTTR_EN | 0: VTTR port is assigned to E_CMP1V2, port VDDQ provides status of E_GPI2 1: VTTR port provides 50% of VDDQ voltage |
| | 2:0 | R/W | BPRO_FB | BUCKPRO feedback signal is created out of: xx1: VBUCKPRO x1x: CORE_SWS 1xx: PERI_SWS Each switch connected to the output of the buck may be selected; setting 0b000 is invalid |

System PMIC for Mobile and Automotive Applications

Table 138: BIO_CONF

| Register Address | Bit | Type | Label | Description |
|------------------|-----|------|-------------------|--|
| 0xA0 BIO_CONF | 7:6 | R/W | BIO_MODE | 00: Sleep/Synchronous mode controlled via voltage A and B registers 10: BUCKIO always operates in Sleep mode 10: BUCKIO always operates in Synchronous 11: BUCKIO operates in Automatic mode |
| | 5 | R/W | BIO_PD_DIS | 0: Enable pull-down resistor 1: No pull-down resistor in disabled mode |
| | 4:3 | | Reserved | |
| | 2:0 | R/W | BIO_FB | BUCKIO feedback signal is created out of: xx1: VBUCKBIO x1x: CORE_SWS 1xx: PERI_SWS Each switch connected to the output of the buck may be selected; setting 0b000 is invalid |

Table 139: BMEM_CONF

| Register Address | Bit | Type | Label | Description |
|-------------------|-----|------|--------------------|--|
| 0xA1 BMEM_CONF | 7:6 | R/W | BMEM_MODE | 00: Sleep/Synchronous mode controlled via voltage A and B registers 01: BUCKMEM always operates in Sleep mode 10: BUCKMEM always operates in Synchronous mode 11: BUCKMEM operates in Automatic mode |
| | 5 | R/W | BMEM_PD_DIS | 0: Enable pull-down resistor 1: No pull-down resistor in disabled mode |
| | 4:3 | | Reserved | |
| | 2:0 | R/W | BMEM_FB | BUCKMEM feedback signal is created out of: xx1: VBUCKMEM x1x: CORE_SWS 1xx: PERI_SWS Each switch connected to the output of the buck may be selected; setting 0b000 is invalid |

System PMIC for Mobile and Automotive Applications

Table 140: BPERI_CONF

| Register Address | Bit | Type | Label | Description |
|--------------------|-----|------|---------------------|---|
| 0xA2 BPERI_CONF | 7:6 | R/W | BPERI_MODE | 00: Sleep/Synchronous mode controlled via voltage A and B registers 01: BUCKPERI always operates in Sleep mode 10: BUCKPERI always operates in Synchronous mode 11: BUCKPERI operates in Automatic mode |
| | 5 | R/W | BPERI_PD_DIS | 0: Enable pull-down resistor 1: No pull-down resistor in disabled mode |
| | 4:3 | | Reserved | |
| | 2:0 | R/W | BPERI_FB | BUCKPERI feedback signal is created out of: xx1: VBUCKPERI x1x: CORE_SWS 1xx: PERI_SWS Each switch connected to the output of the buck may be selected; setting 0b0000 is invalid |

Table 141: VBCORE2_A

| Register Address | Bit | Type | Label | Description |
|-------------------|-----|------|--------------------|--|
| 0xA3 VBCORE2_A | 7 | R/W | BCORE2_SL_A | 0: Configures BUCKCORE2 to Synchronous mode, when selecting A voltage settings 1: Configures BUCKCORE2 to Sleep mode, when selecting A voltage settings |
| | 6:0 | R/W | VBCORE2_A | 0000000: 0.30 V 0000001: 0.31 V 0000010: 0.32 V 0000011: 0.33 V 0000100: 0.34 V 0000101: 0.35 V ... 0100101: 0.67 V 0100110: 0.68 V 0100111: 0.69 V |

System PMIC for Mobile and Automotive Applications

| Register Address | Bit | Type | Label | Description |
|------------------|-----|------|-------|---|
| | | | | 0101000: 0.70 V 0101001: 0.71 V ... 1010000: 1.10 V ... 1110011: 1.45 V 1110100: 1.46 V 1110101: 1.47 V 1110110: 1.48 V 1110111: 1.49 V 1111000: 1.50 V 1111001: 1.51 V 1111010: 1.52 V 1111011: 1.53 V 1111100: 1.54 V 1111101: 1.55 V 1111110: 1.56 V 1111111: 1.57 V |
| | | | | PWM mode voltage range |

Table 142: VBCORE1_A

| Register Address | Bit | Type | Label | Description |
|-------------------|-----|------|--------------------|--|
| 0xA4 VBCORE1_A | 7 | R/W | BCORE1_SL_A | 0: Configures BUCKCORE1 to Synchronous mode, when selecting A voltage settings 1: Configures BUCKCORE1 to Sleep mode, when selecting A voltage settings |
| | 6:0 | R/W | VBCORE1_A | 0000000: 0.30 V 0000001: 0.31 V 0000010: 0.32 V 0000011: 0.33 V 0000100: 0.34 V 0000101: 0.35 V ... 0100101: 0.67 V 0100110: 0.68 V 0100111: 0.69 V ... 1010000: 1.10 V ... 1110011: 1.45 V 1110100: 1.46 V 1110101: 1.47 V 1110110: 1.48 V 1110111: 1.49 V 1111000: 1.50 V 1111001: 1.51 V 1111010: 1.52 V 1111011: 1.53 V 1111100: 1.54 V 1111101: 1.55 V 1111110: 1.56 V 1111111: 1.57 V |
| | | | | PWM mode voltage range |

System PMIC for Mobile and Automotive Applications

Table 143: VBPRO_A

| Register Address | Bit | Type | Label | Description |
|------------------|-----|------|------------------|---|
| 0xA5 VBPRO_A | 7 | R/W | BPRO_SL_A | 0: Configures BUCKPRO to Synchronous mode, when selecting A voltage settings 1: Configures BUCKPRO to Sleep mode, when selecting A voltage settings |
| | 6:0 | R/W | VBPRO_A | 0000000: 0.53 V 0000001: 0.54 V 0000010: 0.55 V 0000011: 0.56 V 0000100: 0.57 V 0000101: 0.58 V ... 0010000: 0.69 V 0010001: 0.70 V 0010010: 0.71 V 0010011: 0.72 V 0010100: 0.73 V 0010101: 0.74 V 0010110: 0.75 V ... 1000011: 1.20 V ... 1110011: 1.68 V 1110100: 1.69 V 1110101: 1.70 V 1110110: 1.71 V 1110111: 1.72 V 1111000: 1.73 V 1111001: 1.74 V 1111010: 1.75 V 1111011: 1.76 V 1111100: 1.77 V 1111101: 1.78 V 1111110: 1.79 V 1111111: 1.80 V |

PWM mode voltage range

Table 144: VBMEM_A

| Register Address | Bit | Type | Label | Description |
|------------------|-----|------|------------------|---|
| 0xA6 VBMEM_A | 7 | R/W | BMEM_SL_A | 0: Configures BUCKMEM to Synchronous mode, when selecting A voltage settings 1: Configures BUCKMEM to Sleep mode, when selecting A voltage settings |
| | 6:0 | R/W | VBMEM_A | 0000000: 0.80 V 0000001: 0.82 V 0000010: 0.84 V ... 0010100: 1.20 V ... 0111100: 2.00 V 0111101: 2.02 V 0111110: 2.04 V 0111111: 2.06 V |

System PMIC for Mobile and Automotive Applications

| Register Address | Bit | Type | Label | Description |
|------------------|-----|------|-------|-------------------------|
| | | | | ... 11111111: 3.34 V |

Table 145: VBIO_A

| Register Address | Bit | Type | Label | Description |
|------------------|-----|------|----------|---|
| 0xA7 VBIO_A | 7 | R/W | BIO_SL_A | 0: Configures BUCKIO to Synchronous mode, when selecting A voltage settings 1: Configures BUCKIO to Sleep mode, when selecting A voltage settings |
| | 6:0 | R/W | VBIO_A | 0000000: 0.80 V 0000001: 0.82 V 0000010: 0.84 V ... 0010100: 1.20 V ... 0111100: 2.00 V 0111101: 2.02 V 0111110: 2.04 V 0111111: 2.06 V ... 1111111: 3.34 V |

System PMIC for Mobile and Automotive Applications

Table 146: VBPERI_A

| Register Address | Bit | Type | Label | Description |
|------------------|-----|------|----------|---|
| 0xA8 VBPERI_A | 7 | R/W | BPERSL_A | 0: Configures BUCKPERI to Synchronous mode, when selecting A voltage settings 1: Configures BUCKPERI to Sleep mode, when selecting A voltage settings |
| | 6:0 | R/W | VBPERI_A | 0000000: 0.80 V 0000001: 0.82 V 0000010: 0.84 V ... 0110010: 1.80 V ... 0111100: 2.00 V 0111101: 2.02 V 0111110: 2.04 V 0111111: 2.06 V ... 1111111: 3.34 V |

Table 147: Reserved

| Register Address | Bit | Type | Label | Description |
|------------------|-----|------|----------|-------------|
| 0xA9, 0xAA | 7:0 | R/W | Reserved | |

Table 148: VLDO3_A

| Register Address | Bit | Type | Label | Description |
|------------------|-----|------|-----------|--|
| 0xAB VLDO3_A | 7 | R/W | LDO3_SL_A | 0: Configures LDO to normal mode, when selecting A voltage settings 1: Configures LDO to Sleep mode, when selecting A voltage settings |
| | 6:0 | R/W | VLDO3_A | 0000000: 0.90 V 0000001: 0.92 V 0000010: 0.94 V 0000011: 0.96 V 0000100: 0.98 V 0000101: 1.00 V 0000110: 1.02 V 0000111: 1.04 V 0001000: 1.06 V 0001001: 1.08 V 0001010: 1.10 V 0001011: 1.12 V 0001100: 1.14 V 0001101: 1.16 V 0001110: 1.18 V 0001111: 1.20 V 0010000: 1.22 V 0010001: 1.24 V 0010010: 1.26 V 0010011: 1.28 V 0010100: 1.30 V 0010101: 1.32 V ... 1110000: 3.14 V 1110001: 3.16 V |

System PMIC for Mobile and Automotive Applications

| Register Address | Bit | Type | Label | Description |
|------------------|-----|------|-------|--|
| | | | | 1110010: 3.18 V 1110011: 3.20 V 1110100: 3.22 V 1110101: 3.24 V 1110110: 3.26 V 1110111: 3.28 V 1111000: 3.30 V 1111001: 3.32 V 1111010: 3.34 V 1111011: 3.36 V 1111100: 3.38 V 1111101: 3.40 V 1111110: 3.42 V 1111111: 3.44 V |

Table 149: Reserved

| Register Address | Bit | Type | Label | Description |
|------------------|-----|------|----------|-------------|
| 0xAC to 0xAE | 7:0 | R/W | Reserved | |

Table 150: VLDO7_A

| Register Address | Bit | Type | Label | Description |
|------------------|-----|------|-----------|---|
| 0xAF VLDO7_A | 7 | R/W | LDO7_SL_A | 0: Configures LDO to normal mode, when selecting A voltage settings 1: Configures LDO to Sleep mode, when selecting A voltage settings |
| | 6 | R/W | Reserved | |
| | 5:0 | R/W | VLDO7_A | 000000: 0.90 V 000001: 0.90 V 000010: 0.90 V 000011: 0.95 V 000100: 1.00 V 000101: 1.05 V 000110: 1.10 V 000111: 1.15 V 001000: 1.20 V 001001: 1.25 V 001010: 1.30 V 001011: 1.35 V 001100: 1.40 V 001101: 1.45 V 001110: 1.50 V 001111: 1.55 V 010000: 1.60 V 010001: 1.65 V 010010: 1.70 V 010011: 1.75 V 010100: 1.80 V 010101: 1.85 V ... 100010: 2.50 V 100011: 2.55 V 100100: 2.60 V 100101: 2.65 V 100110: 2.70 V 100111: 2.75 V |

System PMIC for Mobile and Automotive Applications

| Register Address | Bit | Type | Label | Description |
|------------------|-----|------|-------|--|
| | | | | 101000: 2.80 V 101001: 2.85 V 101010: 2.90 V 101011: 2.95 V 101100: 3.00 V 101101: 3.05 V 101110: 3.10 V 101111: 3.15 V 110000: 3.20 V 110001: 3.25 V 110010: 3.30 V 110011: 3.35 V 110100: 3.40 V 110101: 3.45 V 110110: 3.50 V 110111: 3.55 V 111000: 3.60 V >111000: 3.60 V |

Table 151: VLDO8_A

| Register Address | Bit | Type | Label | Description |
|------------------|-----|------|------------------|--|
| 0xB0 VLDO8_A | 7 | R/W | LDO8_SL_A | 0: Configures LDO to normal mode, when selecting A voltage settings 1: Configures LDO to Sleep mode, when selecting A voltage settings |
| | 6 | R/W | Reserved | |
| | 5:0 | R/W | VLDO8_A | 000000: 0.90 V 000001: 0.90 V 000010: 0.90 V 000011: 0.95 V 000100: 1.00 V 000101: 1.05 V 000110: 1.10 V 000111: 1.15 V 001000: 1.20 V 001001: 1.25 V 001010: 1.30 V 001011: 1.35 V 001100: 1.40 V 001101: 1.45 V 001110: 1.50 V 001111: 1.55 V 010000: 1.60 V 010001: 1.65 V 010010: 1.70 V 010011: 1.75 V 010100: 1.80 V 010101: 1.85 V ... 100010: 2.50 V 100011: 2.55 V 100100: 2.60 V 100101: 2.65 V 100110: 2.70 V 100111: 2.75 V 101000: 2.80 V 101001: 2.85 V |

System PMIC for Mobile and Automotive Applications

| Register Address | Bit | Type | Label | Description |
|------------------|-----|------|-------|---|
| | | | | 101010: 2.90 V 101011: 2.95 V 101100: 3.00 V 101101: 3.05 V 101110: 3.10 V 101111: 3.15 V 110000: 3.20 V 110001: 3.25 V 110010: 3.30 V 110011: 3.35 V 110100: 3.40 V 110101: 3.45 V 110110: 3.50 V 110111: 3.55 V 111000: 3.60 V >111000: 3.60 V |

Table 152: VLDO9_A

| Register Address | Bit | Type | Label | Description |
|------------------|-----|------|-----------|--|
| 0xB1 VLDO9_A | 7 | R/W | LDO9_SL_A | 0: Configures LDO to normal mode, when selecting A voltage settings 1: Configures LDO to Sleep mode, when selecting A voltage settings |
| | 6 | R/W | Reserved | |
| | 5:0 | R/W | VLDO9_A | 000000: not used 000001: 0.95 V 000010: 0.95 V 000011: 0.95 V 000100: 1.00 V 000101: 1.05 V 000110: 1.10 V 000111: 1.15 V 001000: 1.20 V 001001: 1.25 V 001010: 1.30 V 001011: 1.35 V 001100: 1.40 V 001101: 1.45 V 001110: 1.50 V 001111: 1.55 V 010000: 1.60 V 010001: 1.65 V 010010: 1.70 V 010011: 1.75 V 010100: 1.80 V 010101: 1.85 V ... 100010: 2.50 V 100011: 2.55 V 100100: 2.60 V 100101: 2.65 V 100110: 2.70 V 100111: 2.75 V 101000: 2.80 V 101001: 2.85 V 101010: 2.90 V 101011: 2.95 V |

System PMIC for Mobile and Automotive Applications

| Register Address | Bit | Type | Label | Description |
|------------------|-----|------|-------|---|
| | | | | 101100: 3.00 V 101101: 3.05 V 101110: 3.10 V 101111: 3.15 V 110000: 3.20 V 110001: 3.25 V 110010: 3.30 V 110011: 3.35 V 110100: 3.40 V 110101: 3.45 V 110110: 3.50 V 110111: 3.55 V 111000: 3.60 V >111000: 3.60 V |

Table 153: Reserved

| Register Address | Bit | Type | Label | Description |
|------------------|-----|------|----------|-------------|
| 0xB2 | 7:0 | R/W | Reserved | |

Table 154: VLDO11_A

| Register Address | Bit | Type | Label | Description |
|------------------|-----|------|------------|---|
| 0xB3 VLDO11_A | 7:4 | R/W | LDO11_SL_A | 0: Configures LDO to normal mode, when selecting A voltage settings 1: Configures LDO to Sleep mode, when selecting A voltage settings |
| | 6 | R/W | Reserved | |
| | 5:0 | R/W | VLDO11_A | 000000: 0.90 V 000001: 0.90 V 000010: 0.90 V 000011: 0.95 V 000100: 1.00 V 000101: 1.05 V 000110: 1.10 V 000111: 1.15 V 001000: 1.20 V 001001: 1.25 V 001010: 1.30 V 001011: 1.35 V 001100: 1.40 V 001101: 1.45 V 001110: 1.50 V 001111: 1.55 V 010000: 1.60 V 010001: 1.65 V 010010: 1.70 V 010011: 1.75 V 010100: 1.80 V 010101: 1.85 V ... 100010: 2.50 V 100011: 2.55 V 100100: 2.60 V 100101: 2.65 V 100110: 2.70 V 100111: 2.75 V |

System PMIC for Mobile and Automotive Applications

| Register Address | Bit | Type | Label | Description |
|------------------|-----|------|-------|-----------------------|
| | | | | 101000: 2.80 V |
| | | | | 101001: 2.85 V |
| | | | | 101010: 2.90 V |
| | | | | 101011: 2.95 V |
| | | | | 101100: 3.00 V |
| | | | | 101101: 3.05 V |
| | | | | 101110: 3.10 V |
| | | | | 101111: 3.15 V |
| | | | | 110000: 3.20 V |
| | | | | 110001: 3.25 V |
| | | | | 110010: 3.30 V |
| | | | | 110011: 3.35 V |
| | | | | 110100: 3.40 V |
| | | | | 110101: 3.45 V |
| | | | | 110110: 3.50 V |
| | | | | 110111: 3.55 V |
| | | | | 111000: 3.60 V |
| | | | | >111000: 3.60 V |

System PMIC for Mobile and Automotive Applications

Table 155: VBCORE2_B

| Register Address | Bit | Type | Label | Description |
|-------------------|-----|------|--------------------|---|
| 0xB4 VBCORE2_B | 7 | R/W | BCORE2_SL_B | 0: Configures BUCKCORE2 to Synchronous mode, when selecting B voltage settings 1: Configures BUCKCORE2 to Sleep mode, when selecting B voltage settings |
| | 6:0 | R/W | VBCORE2_B | 0000000: 0.30 V 0000001: 0.31 V 0000010: 0.32 V 0000011: 0.33 V 0000100: 0.34 V 0000101: 0.35 V ... 0100101: 0.67 V 0100110: 0.68 V 0100111: 0.69 V 0101000: 0.70 V 0101001: 0.71 V ... 0111100: 0.90 V ... 1110011: 1.45 V 1110100: 1.46 V 1110101: 1.47 V 1110110: 1.48 V 1110111: 1.49 V 1111000: 1.50 V 1111001: 1.51 V 1111010: 1.52 V 1111011: 1.53 V 1111100: 1.54 V 1111101: 1.55 V 1111110: 1.56 V 1111111: 1.57 V |
| | | | | PWM mode voltage range |

Table 156: VBCORE1_B

| Register Address | Bit | Type | Label | Description |
|-------------------|-----|------|--------------------|---|
| 0xB5 VBCORE1_B | 7 | R/W | BCORE1_SL_B | 0: Configures BUCKCORE1 to Synchronous mode, when selecting B voltage settings 1: Configures BUCKCORE1 to Sleep mode, when selecting B voltage settings |
| | 6:0 | R/W | VBCORE1_B | 0000000: 0.30 V 0000001: 0.31 V 0000010: 0.32 V 0000011: 0.33 V 0000100: 0.34 V 0000101: 0.35 V ... 0100101: 0.67 V 0100110: 0.68 V 0100111: 0.69 V 0101000: 0.70 V 0101001: 0.71 V ... |
| | | | | PWM mode voltage range |

System PMIC for Mobile and Automotive Applications

| Register Address | Bit | Type | Label | Description |
|------------------|-----|------|-------|--|
| | | | | 0111100: 0.90 V ... 1110011: 1.45 V 1110100: 1.46 V 1110101: 1.47 V 1110110: 1.48 V 1110111: 1.49 V 1111000: 1.50 V 1111001: 1.51 V 1111010: 1.52 V 1111011: 1.53 V 1111100: 1.54 V 1111101: 1.55 V 1111110: 1.56 V 1111111: 1.57 V |

Table 157: VBPRO_B

| Register Address | Bit | Type | Label | Description |
|------------------|-----|------|------------------|---|
| 0xB6 VBPRO_B | 7 | R/W | BPRO_SL_B | 0: Configures BUCKPRO to Synchronous mode, when selecting B voltage settings 1: Configures BUCKPRO to Sleep mode, when selecting B voltage settings |
| | 6:0 | R/W | VBPRO_B | 0000000: 0.53 V 0000001: 0.54 V 0000010: 0.55 V 0000011: 0.56 V 0000100: 0.57 V 0000101: 0.58 V ... 0010000: 0.69 V 0010001: 0.70 V 0010010: 0.71 V 0010011: 0.72 V 0010100: 0.73 V 0010101: 0.74 V 0010110: 0.75 V ... 1000011: 1.20 V ... 1110011: 1.68 V 1110100: 1.69 V 1110101: 1.70 V 1110110: 1.71 V 1110111: 1.72 V 1111000: 1.73 V 1111001: 1.74 V 1111010: 1.75 V 1111011: 1.76 V 1111100: 1.77 V 1111101: 1.78 V 1111110: 1.79 V 1111111: 1.80 V |

PWM mode voltage range

System PMIC for Mobile and Automotive Applications

Table 158: VBMEM_B

| Register Address | Bit | Type | Label | Description |
|------------------|-----|------|------------------|---|
| 0xB7 VBMEM_B | 7 | R/W | BMEM_SL_B | 0: Configures BUCKMEM to Synchronous mode, when selecting B voltage settings 1: Configures BUCKMEM to Sleep mode, when selecting B voltage settings |
| | 6:0 | R/W | VBMEM_B | 0000000: 0.80 V 0000001: 0.82 V 0000010: 0.84 V ... 0010100: 1.20 V ... 0111100: 2.00 V 0111101: 2.02 V 0111110: 2.04 V 0111111: 2.06 V ... 1111111: 3.34 V |

Table 159: VBIO_B

| Register Address | Bit | Type | Label | Description |
|------------------|-----|------|-----------------|---|
| 0xB8 VBIO_B | 7 | R/W | BIO_SL_B | 0: Configures BUCKIO to Synchronous mode, when selecting B voltage settings 1: Configures BUCKIO to Sleep mode, when selecting B voltage settings |
| | 6:0 | R/W | VBIO_B | 0000000: 0.80 V 0000001: 0.82 V 0000010: 0.84 V ... 0010100: 1.20 V ... 0111100: 2.00 V 0111101: 2.02 V 0111110: 2.04 V 0111111: 2.06 V ... 1111111: 3.34 V |

Table 160: VBPERI_B

| Register Address | Bit | Type | Label | Description |
|------------------|-----|------|-------------------|---|
| 0xB9 VBPERI_B | 7 | R/W | BPERI_SL_B | 0: Configures BUCKPERI to Synchronous mode, when selecting A voltage settings 1: Configures BUCKPERI to Sleep mode, when selecting B voltage settings |
| | 6:0 | R/W | VBPERI_B | 0000000: 0.80 V 0000001: 0.82 V 0000010: 0.84 V ... 0110010: 1.80 V ... 0111100: 2.00 V 0111101: 2.02 V 0111110: 2.04 V 0111111: 2.06 V |

System PMIC for Mobile and Automotive Applications

| Register Address | Bit | Type | Label | Description |
|------------------|-----|------|-------|-------------------------|
| | | | | ... 11111111: 3.34 V |

Table 161: Reserved

| Register Address | Bit | Type | Label | Description |
|------------------|-----|------|----------|-------------|
| 0xBA, 0xBB | 7:0 | R/W | Reserved | |

Table 162: VLDO3_B

| Register Address | Bit | Type | Label | Description |
|------------------|-----|------|-----------|--|
| 0xBC VLDO3_B | 7 | R/W | LDO3_SL_B | 0: Configures LDO to normal mode, when selecting B voltage settings 1: Configures LDO to Sleep mode, when selecting B voltage settings |
| | 6:0 | R/W | VLDO3_B | 0000000: 0.90 V 0000001: 0.92 V 0000010: 0.94 V 0000011: 0.96 V 0000100: 0.98 V 0000101: 1.00 V 0000110: 1.02 V 0000111: 1.04 V 0001000: 1.06 V 0001001: 1.08 V 0001010: 1.10 V 0001011: 1.12 V 0001100: 1.14 V 0001101: 1.16 V 0001110: 1.18 V 0001111: 1.20 V 0010000: 1.22 V 0010001: 1.24 V 0010010: 1.26 V 0010011: 1.28 V 0010100: 1.30 V 0010101: 1.32 V ... 1110000: 3.14 V 1110001: 3.16 V 1110010: 3.18 V 1110011: 3.20 V 1110100: 3.22 V 1110101: 3.24 V 1110110: 3.26 V 1110111: 3.28 V 1111000: 3.30 V 1111001: 3.32 V 1111010: 3.34 V 1111011: 3.36 V 1111100: 3.38 V 1111101: 3.40 V 1111110: 3.42 V 1111111: 3.44 V |

System PMIC for Mobile and Automotive Applications

Table 163: Reserved

| Register Address | Bit | Type | Label | Description |
|------------------|-----|------|----------|-------------|
| 0xBD to 0xBF | 7:0 | R/W | Reserved | |

Table 164: VLDO7_B

| Register Address | Bit | Type | Label | Description |
|------------------|-----|------|-----------|--|
| 0xC0 VLDO7_B | 7 | R/W | LDO7_SL_B | 0: Configures LDO to normal mode, when selecting B voltage settings 1: Configures LDO to Sleep mode, when selecting B voltage settings |
| | 6 | R/W | Reserved | |

System PMIC for Mobile and Automotive Applications

| Register Address | Bit | Type | Label | Description |
|------------------|-----|------|---------|---|
| | 5:0 | R/W | VLDO7_B | 000000: 0.90 V 000001: 0.90 V 000010: 0.90 V 000011: 0.95 V 000100: 1.00 V 000101: 1.05 V 000110: 1.10 V 000111: 1.15 V 001000: 1.20 V 001001: 1.25 V 001010: 1.30 V 001011: 1.35 V 001100: 1.40 V 001101: 1.45 V 001110: 1.50 V 001111: 1.55 V 010000: 1.60 V 010001: 1.65 V 010010: 1.70 V 010011: 1.75 V 010100: 1.80 V 010101: 1.85 V ... 100010: 2.50 V 100011: 2.55 V 100100: 2.60 V 100101: 2.65 V 100110: 2.70 V 100111: 2.75 V 101000: 2.80 V 101001: 2.85 V 101010: 2.90 V 101011: 2.95 V 101100: 3.00 V 101101: 3.05 V 101110: 3.10 V 101111: 3.15 V 110000: 3.20 V 110001: 3.25 V 110010: 3.30 V 110011: 3.35 V 110100: 3.40 V 110101: 3.45 V 110110: 3.50 V 110111: 3.55 V 111000: 3.60 V >111000: 3.60 V |

System PMIC for Mobile and Automotive Applications

Table 165: VLDO8_B

| Register Address | Bit | Type | Label | Description |
|------------------|-----|------|-----------|---|
| 0xC1 VLDO8_B | 7 | R/W | LDO8_SL_B | 0: Configures LDO to normal mode, when selecting B voltage settings 1: Configures LDO to Sleep mode, when selecting B voltage settings |
| | 6 | R/W | Reserved | |
| | 5:0 | R/W | VLDO8_B | 000000: 0.90 V 000001: 0.90 V 000010: 0.90 V 000011: 0.95 V 000100: 1.00 V 000101: 1.05 V 000110: 1.10 V 000111: 1.15 V 001000: 1.20 V 001001: 1.25 V 001010: 1.30 V 001011: 1.35 V 001100: 1.40 V 001101: 1.45 V 001110: 1.50 V 001111: 1.55 V 010000: 1.60 V 010001: 1.65 V 010010: 1.70 V 010011: 1.75 V 010100: 1.80 V 010101: 1.85 V ... 100010: 2.50 V 100011: 2.55 V 100100: 2.60 V 100101: 2.65 V 100110: 2.70 V 100111: 2.75 V 101000: 2.80 V 101001: 2.85 V 101010: 2.90 V 101011: 2.95 V 101100: 3.00 V 101101: 3.05 V 101110: 3.10 V 101111: 3.15 V 110000: 3.20 V 110001: 3.25 V 110010: 3.30 V 110011: 3.35 V 110100: 3.40 V 110101: 3.45 V 110110: 3.50 V 110111: 3.55 V 111000: 3.60 V >111000: 3.60 V |

System PMIC for Mobile and Automotive Applications

Table 166: VLDO9_B

| Register Address | Bit | Type | Label | Description |
|------------------|-----|------|-----------|---|
| 0xC2 VLDO9_B | 7 | R/W | LDO9_SL_B | 0: Configures LDO to normal mode, when selecting B voltage settings 1: Configures LDO to Sleep mode, when selecting B voltage settings |
| | 6 | R/W | Reserved | |
| | 5:0 | R/W | VLDO9_B | 000000: 0.95 V 000001: 0.95 V 000010: 0.95 V 000011: 0.95 V 000100: 1.00 V 000101: 1.05 V 000110: 1.10 V 000111: 1.15 V 001000: 1.20 V 001001: 1.25 V 001010: 1.30 V 001011: 1.35 V 001100: 1.40 V 001101: 1.45 V 001110: 1.50 V 001111: 1.55 V 010000: 1.60 V 010001: 1.65 V 010010: 1.70 V 010011: 1.75 V 010100: 1.80 V 010101: 1.85 V ... 100010: 2.50 V 100011: 2.55 V 100100: 2.60 V 100101: 2.65 V 100110: 2.70 V 100111: 2.75 V 101000: 2.80 V 101001: 2.85 V 101010: 2.90 V 101011: 2.95 V 101100: 3.00 V 101101: 3.05 V 101110: 3.10 V 101111: 3.15 V 110000: 3.20 V 110001: 3.25 V 110010: 3.30 V 110011: 3.35 V 110100: 3.40 V 110101: 3.45 V 110110: 3.50 V 110111: 3.55 V 111000: 3.60 V >111000: 3.60 V |

System PMIC for Mobile and Automotive Applications

Table 167: Reserved

| Register Address | Bit | Type | Label | Description |
|------------------|-----|------|----------|-------------|
| 0xC3 | 7:0 | R/W | Reserved | |

Table 168: VLDO11_B

| Register Address | Bit | Type | Label | Description |
|------------------|-----|------|-----------|---|
| 0xC4 VLDO11_B | 7:4 | R/W | LDO1_SL_B | 0: Configures LDO to normal mode, when selecting B voltage settings 1: Configures LDO to Sleep mode, when selecting B voltage settings |
| | 6 | R/W | Reserved | |
| | 5:0 | R/W | VLDO11_B | 000000: 0.90 V 000001: 0.90 V 000010: 0.90 V 000011: 0.95 V 000100: 1.00 V 000101: 1.05 V 000110: 1.10 V 000111: 1.15 V 001001: 1.25 V 001010: 1.30 V 001011: 1.35 V 001100: 1.40 V 001101: 1.45 V 001110: 1.50 V 001111: 1.55 V 010000: 1.60 V 010001: 1.65 V 010010: 1.70 V 010011: 1.75 V 010100: 1.80 V 010101: 1.85 V ... 100010: 2.50 V 100011: 2.55 V 100100: 2.60 V 100101: 2.65 V 100110: 2.70 V 100111: 2.75 V 101000: 2.80 V 101001: 2.85 V 101010: 2.90 V 101011: 2.95 V 101100: 3.00 V 101101: 3.05 V 101110: 3.10 V 101111: 3.15 V 110000: 3.20 V 110001: 3.25 V 110010: 3.30 V 110011: 3.35 V 110100: 3.40 V 110101: 3.45 V 110110: 3.50 V 110111: 3.55 V 111000: 3.60 V >111000: 3.60 V |

System PMIC for Mobile and Automotive Applications

A.3.3 High Power GPO PWM

Table 169: GPO11_LED

| Register Address | Bit | Type | Label | Description |
|-------------------|-----|------|------------------|--|
| 0xC6 GPO11_LED | 7 | R/W | GPO11_DIM | 0: PWM ratio changes instantly 1: GPO ramps between changes in PWM ratio with 32 ms per step |
| | 6:0 | R/W | GPO11_PWM | GPO11 LED on-time (low level at GPIO 11, period 21 kHz = 95 cycles of 0.5 μ s) 0000000: off 0000001: 1% 0000010: 2% (1 μ s bursts) 0000011: 3% 0000100: 4% 0000101: 5% 0000110: 6% 0000111: 7% 0001000: 8% 0001001: 9% 0001010: 10% 0001011: 11% 0001100: 12% 0001101: 13% 0001110: 14% 0001111: 15% 0010000: 16% 1011111: 100% >1011111: 100% |

Table 170: GPO14_LED

| Register Address | Bit | Type | Label | Description |
|-------------------|-----|------|------------------|---|
| 0xC7 GPO14_LED | 7 | R/W | GPO14_DIM | 0: PWM ratio changes instantly 1: GPO ramps between changes in PWM ratio with 32 ms per step |
| | 6:0 | R/W | GPO14_PWM | GPO14 LED on-time (low level at GPIO 14, period 21 kHz = 95 cycles of 0.5 μ s) 0000000: off 0000001: 1% 0000010: 2% (1 μ s bursts) 0000011: 3% 0000100: 4% 0000101: 5% 0000110: 6% 0000111: 7% 0001000: 8% 0001001: 9% 0001010: 10% 0001011: 11% 0001100: 12% 0001101: 13% 0001110: 14% 0001111: 15% 0010000: 16% |

System PMIC for Mobile and Automotive Applications

| Register Address | Bit | Type | Label | Description |
|------------------|-----|------|-------|---------------------------------|
| | | | | 1011111: 100% >1011111: 100% |

Table 171: GPO15_LED

| Register Address | Bit | Type | Label | Description |
|-------------------|-----|------|------------------|--|
| 0xC8 GPO15_LED | 7 | R/W | GPO15_DIM | 0: PWM ratio changes instantly 1: GPO ramps between changes in PWM ratio with 32 ms per step |
| | 6:0 | R/W | GPO15_PWM | GPO15 LED on-time (low level at GPIO 15, period 21 kHz = 95 cycles of 0.5 μ s) 0000000: off 0000001: 1% 0000010: 2% (1 μ s bursts) 0000011: 3% 0000100: 4% 0000101: 5% 0000110: 6% 0000111: 7% 0001000: 8% 0001001: 9% 0001010: 10% 0001011: 11% 0001100: 12% 0001101: 13% 0001110: 14% 0001111: 15% 0010000: 16% 1011111: 100% >1011111: 100% |

A.3.4 GPADC Thresholds

Table 172: ADC_CFG

| Register Address | Bit | Type | Label | Description |
|------------------|-----|------|-------------------|---|
| 0xC9 ADC_CFG | 7 | R/W | ADCIN3_DEB | 0: ADCIN3: debouncing off 1: ADCIN3: debouncing on |
| | 6 | R/W | ADCIN2_DEB | 0: ADCIN2: debouncing off 1: ADCIN2: debouncing on |
| | 5 | R/W | ADCIN1_DEB | 0: ADCIN1: debouncing off 1: ADCIN1: debouncing on |
| | 4 | R/W | ADCIN3_CUR | ADCIN3 current source: 0: 10 μA 1: 40 μ A |
| | 3:2 | R/W | ADCIN2_CUR | ADCIN2 current source: 00: 1 μ A 01: 2.5 μ A 10: 10 μA 11: 40 μ A |
| | 1:0 | R/W | ADCIN1_CUR | ADCIN1 current source: |

System PMIC for Mobile and Automotive Applications

| Register Address | Bit | Type | Label | Description |
|------------------|-----|------|-------|---|
| | | | | 00: 1 μ A 01: 2.5 μ A 10: 10 μA 11: 40 μ A |

Table 173: AUTO1_HIGH

| Register Address | Bit | Type | Label | Description |
|--------------------|-----|------|-------------------|--|
| 0xCA AUTO1_HIGH | 7:0 | R/W | AUTO1_HIGH | 00000000 – 11111111: ADCIN1 high level threshold |

Table 174: AUTO1_LOW

| Register Address | Bit | Type | Label | Description |
|-------------------|-----|------|------------------|---|
| 0xCB AUTO1_LOW | 7:0 | R/W | AUTO1_LOW | 00000000 – 11111111: ADCIN1 low level threshold |

Table 175: AUTO2_HIGH

| Register Address | Bit | Type | Label | Description |
|--------------------|-----|------|-------------------|--|
| 0xCC AUTO2_HIGH | 7:0 | R/W | AUTO2_HIGH | 00000000 – 11111111: ADCIN2 high level threshold |

Table 176: AUTO2_LOW

| Register Address | Bit | Type | Label | Description |
|-------------------|-----|------|------------------|---|
| 0xCD AUTO2_LOW | 7:0 | R/W | AUTO2_LOW | 00000000 – 11111111: ADCIN2 low level threshold |

Table 177: AUTO3_HIGH

| Register Address | Bit | Type | Label | Description |
|--------------------|-----|------|-------------------|--|
| 0xCE AUTO3_HIGH | 7:0 | R/W | AUTO3_HIGH | 00000000 – 11111111: ADCIN3 high level threshold |

Table 178: AUTO3_LOW

| Register Address | Bit | Type | Label | Description |
|-------------------|-----|------|------------------|---|
| 0xCF AUTO3_LOW | 7:0 | R/W | AUTO3_LOW | 00000000 – 11111111: ADCIN3 low level threshold |

Table 179: Copmic_S to Copmic_E

| Register Address | Bit | Type | Label | Description |
|------------------|-----|------|----------|----------------------|
| 0xD0 CoPMIC_S | 7:0 | R | Reserved | Reserved for Co-PMIC |
| 0xDF CoPMIC_E | 7:0 | R | Reserved | Reserved for Co-PMIC |

System PMIC for Mobile and Automotive Applications**Table 180: CHG_Co_S to CHG_Co_E**

| Register Address | Bit | Type | Label | Description |
|------------------|-----|------|----------|--------------------------------|
| 0xE0 CHG_Co_S | 7:0 | R | Reserved | Reserved for companion charger |
| 0xFF CHG_Co_E | 7:0 | R | Reserved | Reserved for companion charger |

System PMIC for Mobile and Automotive Applications

A.4 Register Page 2

Table 181: PAGE_CON

| Register Address | Bit | Type | Label | Description |
|-------------------|-----|------|------------|---|
| 0x100 PAGE_CON | 7 | RW | REVERT | See register 0x00, Table 43 |
| | 6 | RW | WRITE_MODE | |
| | 5:3 | RW | Reserved | |
| | 2:0 | RW | REG_PAGE | |

A.4.1 OTP

Table 182: OTP_CONT

| Register Address | Bit | Type | Label | Description |
|-------------------|-----|------|---------------|--|
| 0x101 OTP_CONT | 7 | R | GP_WRITE_DIS | 0: Enables write access to GP_ID registers 1: GP_ID_0to GP_ID_9 registers are 'read only' |
| | 6 | R | OTP_CONF_LOCK | 0: Registers 0x0A to 0x36 and 0x82 to 0xCF are not locked for OTP programming (only for evaluation samples) 1: OTP registers 0x0A to 0x36 and 0x82 to 0xCF are locked in OTP (set for all mass production parts, no further fusing possible) |
| | 5 | R | OTP_APPS_LOCK | 0: Registers 0x104 to 0x117 are not locked for OTP programming (only for evaluation samples) 1: OTP registers 0x104 to 0x117 are locked in OTP (set for all mass production parts, no further fusing possible) |
| | 4 | R | OTP_GP_LOCK | 0: Registers 0x120 to 0x134 are not locked for OTP programming 1: Registers 0x120 to 0x134 are locked in OTP (no further fusing possible if once fused with 1) |
| | 3 | R/W | PC_DONE | Asserted from PowerCommander SW after emulated OTP read has finished (control shared with Co-PMIC), automatically cleared when leaving emulated OTP read |
| | 2 | R/W | OTP_APPS_RD | Reads on assertion application specific registers (0x104 to 0x117 and OTP_APPS_LOCK) from OTP |
| | 1 | R/W | OTP_GP_RD | Reads on assertion device specific registers 0x120 to 0x134 (plus GP_WRITE_DIS and OTP_GP_LOCK) from OTP |
| | 0 | R/W | OTP_TIM | OTP read timing 0: normal read 1: marginal read (for OTP fuse verification) |

System PMIC for Mobile and Automotive Applications

Table 183: OTP_ADDR

| Register Address | Bit | Type | Label | Description |
|-------------------|-----|------|----------|---|
| 0x102 OTP_ADDR | 7:0 | R/W | OTP_ADDR | OTP Array address (shared with Companion ICs) |

Table 184: OTP_DATA

| Register Address | Bit | Type | Label | Description |
|-------------------|-----|------|----------|--|
| 0x103 OTP_DATA | 7:0 | R/W | OTP_DATA | OTP read/write data (shared with Companion ICs) OTP_DATA written to OTP_ADDR selects the IC and accepts unlock sequence (1 + 3 bytes) |

A.4.2 Customer Trim and Configuration

Table 185: T_OFFSET

| Register Address | Bit | Type | Label | Description |
|-------------------|-----|------|----------|---|
| 0x104 T_OFFSET | 7:0 | R | T_OFFSET | 10000000 – 01111111: signed two's complement calibration offset for junction temperature measurement (loaded from the OTP memory, must be programmed during production) |

Table 186: INTERFACE

| Register Address | Bit | Type Note 1 | Label | Description |
|--------------------|-----|--------------------------------|--------------|---|
| 0x105 INTERFACE | 7:4 | R | IF_BASE_ADDR | 4 MSB of 2-WIRE control interfaces base address XXXX0000 10110100 = 0xB4 write address of HS 2-WIRE interface (page 0 and 1) 10110101 = 0xB5 read address of HS 2-WIRE interface (page 0 and 1) 10110110 = 0xB6 write address of HS 2-WIRE interface (page 2 and 3) 10110111 = 0xB7 read address of HS 2-WIRE interface (page 2 and 3) Code '0000' is reserved for unprogrammed OTP (triggers start-up with hardware default interface address) |
| | 3:0 | R | Reserved | |

Note 1 The interface configuration can be written/modified only for unmarked samples which do not have the control OTP_APPS_LOCK asserted/fused.

System PMIC for Mobile and Automotive Applications

Table 187: CONFIG_A

| Register Address | Bit | Type | Label | Description |
|-------------------|-----|------|-----------|--|
| 0x106 CONFIG_A | 7:4 | R/W | Reserved | |
| | 3 | R/W | IRQ_TYPE | nIRQ output is: 0: Active low 1: Active high (invert signal) |
| | 2 | R/W | PM_O_TYPE | nRESET, nIRQ output are: 0: Push-pull 1: Open drain (requires external pull-up resistor) |
| | 1 | R/W | PM_O_V | E_GPI_2, COMP1V2, nRESET, nIRQ are supplied from: 0: VDD_IO1 1: VDD_IO2 |
| | 0 | R/W | PM_I_V | nONKEY, nOFF, nSHUTDOWN, SYS_EN, PWR_EN, PWR1_EN, KEEP_ACT, nVIB_BRAKE are supplied from: 0: VDDCORE 1: VDD_IO2 |

Table 188: CONFIG_B

| Register Address | Bit | Type | Label | Description |
|-------------------|-----|------|---------------|---|
| 0x107 CONFIG_B | 7 | R/W | Reserved | |
| | 6:4 | R/W | VDD_HYST_ADJ | Hysteresis adjust of VDD_FAULT comparator (VDD_FAULT_UPPER) in 50 mV steps 000: 100 mV 001: 150 mV ... 111: 450 mV |
| | 3:0 | R/W | VDD_FAULT_ADJ | Setting of VDD_FAULT_LOWER comparator in 50 mV steps 0000: 2.50 V 0001: 2.55 V ... 0110: 2.80 V ... 1110: 3.20 V 1111: 3.25 V |

Table 189: CONFIG_C

| Register Address | Bit | Type | Label | Description |
|-------------------|-----|------|---------------|---|
| 0x108 CONFIG_C | 7 | R/W | BPERI_CLK_INV | BUCKPERI clock polarity 0: Normal 1: Inverted |
| | 6 | R/W | BIO_CLK_INV | BUCKIO clock polarity |

System PMIC for Mobile and Automotive Applications

| Register Address | Bit | Type | Label | Description |
|------------------|-----|------|-----------------------|--|
| | | | | 0: Normal 1: Inverted |
| | 5 | R/W | BMEM_CLK_INV | BUCKMEM clock polarity 0: Normal 1: Inverted |
| | 4 | R/W | BPRO_CLK_INV | BUCKPRO clock polarity (should be configured opposite to BUCKMEM clock polarity) 0: Normal 1: Inverted |
| | 3 | R/W | BCORE1_CLK_INV | BUCKCORE1 clock polarity (BUCKCORE2 always runs on opposite clock polarity) 0: Normal 1: Inverted |
| | 2 | R/W | BUCK_DISCHG | Enable active discharge of buck rails |
| | 1:0 | R/W | Reserved | |

Table 190: CONFIG_D

| Register Address | Bit | Type | Label | Description |
|-------------------|-----|------|---------------------|---|
| 0x109 CONFIG_D | 7 | R/W | GP_FB3_TYPE | GP_FB3 output is: 0: Active low 1: Active high (invert signal) |
| | 6 | R/W | GP_FB2_TYPE | GP_FB2 output is: 0: Active low (invert signal, push-pull for PWR_OK) 1: Active high (open drain for PWR_OK) |
| | 5 | R/W | FORCE_RESET | Asserts port nRESET in case of being set |
| | 4 | R/W | HS_IF_HSM | Enables continuous High Speed mode on HS 2-WIRE IF (no master code required) |
| | 3 | R/W | HS_IF_FMP | Selects fast-mode+ timings for HS 2-WIRE IF if asserted |
| | 2 | R/W | SYSTEM_EN_RD | During second OTP read control SYSTEM_EN is 0: updated from OTP 1: not changed |
| | 1 | R/W | nIRQ_MODE | nIRQ will be asserted from events during POWERDOWN mode (and modes lower than ACTICE) 0: immediately 1: after powering up to ACTIVE mode |
| | 0 | R/W | GPI_V | GPIs (not configured as Power Manager control inputs) and HS 2-WIRE IF are supplied from: 0: VDDCORE 1: VDD_IO2 |

System PMIC for Mobile and Automotive Applications

Table 191: CONFIG_E

| Register Address | Bit | Type | Label | Description |
|-------------------|-----|------|---------------------|---|
| 0x10A CONFIG_E | 7 | R/W | PERI_SW_AUTO | Selects PERI_SW (during powering up): 0: configured from PERI_SW_CONF 1: enabled |
| | 6 | R/W | CORE_SW_AUTO | Selects CORE_SW (during powering up): 0: configured from CORE_SW_CONF 1: enabled |
| | 5 | R/W | BPERI_AUTO | Selects BUCKPERI (during powering up): 0: configured from BPERI_CONF 1: enabled |
| | 4 | R/W | BIO_AUTO | Selects BUCKIO (during powering up): 0: configured from BIO_CONF 1: enabled |
| | 3 | R/W | BMEM_AUTO | Selects BUCKMEM (during powering up): 0: configured from BMEM_CONF 1: enabled |
| | 2 | R/W | BPRO_AUTO | Selects BUCKPRO (during powering up): 0: configured from BPRO_CONF 1: enabled |
| | 1 | R/W | BCORE2_AUTO | Selects BUCKCORE2 (during powering up): 0: configured from BCORE2_CONF 1: enabled |
| | 0 | R/W | BCORE1_AUTO | Selects BUCKCORE1 (during powering up): 0: configured from BCORE1_CONF 1: enabled |

Table 192: CONFIG_F

| Register Address | Bit | Type | Label | Description |
|-------------------|-----|------|-------------------|--|
| 0x10B CONFIG_F | 7 | R/W | LDO11_BYP | 0: LDO11 is configured for regulator mode 1: LDO11 bypass mode enabled |
| | 6 | R/W | LDO8_BYP | 0: LDO8 is configured for regulator mode 1: LDO8 bypass mode enabled |
| | 5 | R/W | LDO7_BYP | 0: LDO7 is configured for regulator mode 1: LDO7 bypass mode enabled |
| | 4 | R/W | Reserved | |
| | 3 | R/W | LDO3_BYP | 0: LDO3 is configured for regulator mode 1: LDO3 bypass mode enabled |
| | 2 | R/W | LDO11_AUTO | Selects LDO11 (during powering up): 0: configured from LDO11_CONF 1: enabled |
| | 1 | R/W | Reserved | |
| | 0 | R/W | LDO9_AUTO | Selects LDO9 (during powering up): |

System PMIC for Mobile and Automotive Applications

| Register Address | Bit | Type | Label | Description |
|------------------|-----|------|-------|--|
| | | | | 0: configured from LDO9_CONF 1: enabled |

Table 193: CONFIG_G

| Register Address | Bit | Type | Label | Description |
|-------------------|-----|------|------------------|--|
| 0x10C CONFIG_G | 7 | R/W | LDO8_AUTO | Selects LDO8 (during powering up): 0: configured from LDO8_CONF 1: enabled |
| | 6 | R/W | LDO7_AUTO | Selects LDO7 (during powering up): 0: configured from LDO7_CONF 1: enabled |
| | 5:3 | R/W | Reserved | |
| | 2 | R/W | LDO3_AUTO | Selects LDO3 (during powering up): 0: configured from LDO3_CONF 1: enabled |
| | 1:0 | R/W | Reserved | |

Table 194: CONFIG_H

| Register Address | Bit | Type | Label | Description |
|-------------------|-----|------|--------------------|---|
| 0x10D CONFIG_H | 7 | R/W | BUCK_MERGE | Has to be set if the outputs of BUCKMEM and BUCKIO are merged towards a single coil; the control from BUCKIO registers is disabled |
| | 6 | R/W | BCORE1_OD | If set, BUCKCORE1 changes to full-current mode (double pass device and current limit) |
| | 5 | R/W | BCORE2_OD | If set, BUCKCORE2 changes to full-current mode (double pass device and current limit) |
| | 4 | R/W | BPRO_OD | If set, BUCKPRO changes to full-current mode (double pass device and current limit) |
| | 3 | R/W | BCORE_MERGE | Has to be set if the outputs of BUCKCORE1 and BUCKCORE2 are merged towards a dual phase buck; the control from BUCKCORE2 registers is disabled |
| | 2 | R/W | MERGE_SENSE | In case BUCKCORE is merged and configured for remote sensing the output capacitor voltage rail is routed to port: 0: GP_FB_2 (setting disables normal GP_FB_2 functionality) 1: CORE_SWS Note: In case MERGE_SENSE is asserted all Bxxx_FB control settings 0bx1x are invalid |
| | 1 | R/W | LDO8_MODE | 0: LDO mode (external capacitor required) |

System PMIC for Mobile and Automotive Applications

| Register Address | Bit | Type | Label | Description |
|------------------|-----|------|---------|--|
| | | | | 1: Vibration motor driver (no external capacitor) |
| | 0 | R/W | PWM_CLK | 0: 2.0 MHz (31.25 kHz repetition frequency) 1: 1.0 MHz (15.6 kHz repetition frequency) |

Table 195: CONFIG_I

| Register Address | Bit | Type | Label | Description |
|-------------------|-----|------|--------------|---|
| 0x10E CONFIG_I | 7 | R/W | LDO_SD | If asserted LDO3, 7, 8 and 11 will shut down after current limit was hit for more than 200 ms |
| | 6 | R/W | INT_SD_MODE | Shut down sequence from internal fault condition is: 0: Normal 1: Fast (skipping seq and dummy slot timers) |
| | 5 | R/W | HOST_SD_MODE | Shut down sequence from SHUTDOWN (register bit or port nSHUTDOWN) is: 0: Normal 1: Fast (skipping seq and dummy slot timers) |
| | 4 | R/W | KEY_SD_MODE | User triggered (nONKEY, GPIO14/15) shutdown sequence is: 0: Normal 1: PMU POR: triggers an instant disable of all regulators incl. LDOCORE (FAULTLOG registers remain unchanged). After leaving POR automatically the RESET_DURATION timer must expire before starting a power-up sequence. |
| | 3 | R/W | GPI14_15_SD | 0: Disables shutdown via parallel assertion of GPI14 and GPI15 1: Enables shutdown via GPI14 & GPI15 |
| | 2 | R/W | nONKEY_SD | nONKEY is configured 0: without shutdown via long press of nONKEY 1: with shutdown via long press of nONKEY |
| | 1:0 | R/W | nONKEY_PIN | nONKEY is configured to 00: Port mode 01: Key mode with key lock during SW triggered POWERDOWN mode 10: Key mode with key locked autonomous powering down (multi-functional key) 11: Key mode with autonomous powering down to partial or key locked full POWERDOWN mode (dedicated power key) Details: see Section 6.1.1 |

System PMIC for Mobile and Automotive Applications

Table 196: CONFIG_J

| Register Address | Bit | Type | Label | Description |
|-------------------|-----|------|-----------------------|--|
| 0x10F CONFIG_J | 7 | R/W | IF_RESET | Enables automatic reset of all control interfaces when port nSHUTDOWN is asserted |
| | 6 | R/W | TWOWIRE_TO | Enables automatic reset of 2-WIRE-IF in case of clock ceases to toggle for >19 ms |
| | 5:4 | R/W | RESET_DURATION | Power controller stays in RESET mode for minimum duration of 00: 20 ms 01: 100 ms 10: 500 ms 11: 1000 ms |
| | 3:2 | R/W | SHUT_DELAY | Long press time threshold for shutdown feature from nONKEY and GPIO14/15: 00: KEY_DELAY + 0 s 01: KEY_DELAY + 4 s 10: KEY_DELAY + 5 s 11: KEY_DELAY + 6 s |
| | 1:0 | R/W | KEY_DELAY | Long press threshold for nONKEY lock: 00: nONKEY_LOCK after 1 s 01: nONKEY_LOCK after 1.5 s 10: nONKEY_LOCK after 2 s 11: nONKEY_LOCK after 7 s |

Note 1 This setting may trigger glidges on regulator outputs and disable the automatic RESET/POR of slave PMUs).

Table 197: CONFIG_K

| Register Address | Bit | Type | Label | Description |
|-------------------|-----|------|-------------------|--|
| 0x110 CONFIG_K | 7 | R/W | GPIO7_PUPD | 0: GPI: pull-down resistor disabled GPO (open drain): pull-up resistor disabled (external pull-up resistor) 1: GPI: pull-down resistor enabled GPO (open drain): pull-up resistor enabled (supply rail selected via GPIOx_TYPE) |
| | 6 | R/W | GPIO6_PUPD | 0: GPI: pull-down resistor disabled GPO (open drain): pull-up resistor disabled (external pull-up resistor) 1: GPI: pull-down resistor enabled GPO (open drain): pull-up resistor enabled (supply rail selected via GPIOx_TYPE) |
| | 5 | R/W | GPIO5_PUPD | 0: GPI: pull-down resistor disabled GPO (open drain): pull-up resistor disabled (external pull-up resistor) 1: GPI: pull-down resistor enabled GPO (open drain): pull-up resistor enabled (supply rail selected via GPIOx_TYPE) |
| | 4 | R/W | GPIO4_PUPD | 0: GPI: pull-down resistor disabled GPO (open drain): pull-up resistor disabled (external pull-up resistor) |

System PMIC for Mobile and Automotive Applications

| Register Address | Bit | Type | Label | Description |
|------------------|-----|------|-------------------|---|
| | | | | 1: GPI: pull-down resistor enabled GPO (open drain): pull-up resistor enabled (supply rail selected via GPIOx_TYPE) |
| | 3 | R/W | GPIO3_PUPD | 0: GPI: pull-down resistor disabled GPO (open drain): pull-up resistor disabled (external pull-up resistor) 1: GPI: pull-down resistor enabled GPO (open drain): pull-up resistor enabled (supply rail selected via GPIOx_TYPE) |
| | 2 | R/W | GPIO2_PUPD | 0: GPI: pull-down resistor disabled GPO (open drain): pull-up resistor disabled (external pull-up resistor) 1: GPI: pull-down resistor enabled GPO (open drain): pull-up resistor enabled (supply rail selected via GPIOx_TYPE) |
| | 1 | R/W | GPIO1_PUPD | 0: GPI: pull-down resistor disabled GPO (open drain): pull-up resistor disabled (external pull-up resistor) 1: GPI: pull-down resistor enabled GPO (open drain): pull-up resistor enabled (supply rail selected via GPIOx_TYPE) |
| | 0 | R/W | GPIO0_PUPD | 0: GPI: pull-down resistor disabled GPO (open drain): pull-up resistor disabled (external pull-up resistor) 1: GPI: pull-down resistor enabled GPO (open drain): pull-up resistor enabled (supply rail selected via GPIOx_TYPE) |

Table 198: CONFIG_L

| Register Address | Bit | Type | Label | Description |
|-------------------|-----|------|--------------------|---|
| 0x111 CONFIG_L | 7 | R/W | GPIO15_PUPD | 0: GPI: pull-down resistor disabled GPO (open drain): pull-up resistor disabled (external pull-up resistor) 1: GPI: pull-down resistor enabled GPO (open drain): pull-up resistor enabled (supply rail selected via GPIOx_TYPE) |
| | 6 | R/W | GPIO14_PUPD | 0: GPI: pull-down resistor disabled GPO (open drain): pull-up resistor disabled (external pull-up resistor) 1: GPI: pull-down resistor enabled GPO (open drain): pull-up resistor enabled (supply rail selected via GPIOx_TYPE) |
| | 5 | R/W | GPIO13_PUPD | 0: GPI: pull-down resistor disabled GPO (open drain): pull-up resistor disabled (external pull-up resistor) 1: GPI: pull-down resistor enabled GPO (open drain): pull-up resistor enabled (supply rail selected via GPIOx_TYPE) |

System PMIC for Mobile and Automotive Applications

| Register Address | Bit | Type | Label | Description |
|------------------|-----|------|--------------------|--|
| | 4 | R/W | GPIO12_PUPD | 0: GPI: pull-down resistor disabled GPO (open drain): pull-up resistor disabled (external pull-up resistor) 1: GPI: pull-down resistor enabled GPO (open drain): pull-up resistor enabled (supply rail selected via GPIOx_TYPE) |
| | 3 | R/W | GPIO11_PUPD | 0: GPI: pull-down resistor disabled GPO (open drain): pull-up resistor disabled (external pull-up resistor) 1: GPI: pull-down resistor enabled GPO (open drain): pull-up resistor enabled (supply rail selected via GPIOx_TYPE) |
| | 2 | R/W | GPIO10_PUPD | 0: GPI: pull-down resistor disabled GPO (open drain): pull-up resistor disabled (external pull-up resistor) 1: GPI: pull-down resistor enabled GPO (open drain): pull-up resistor enabled (supply rail selected via GPIOx_TYPE) |
| | 1 | R/W | GPIO9_PUPD | 0: GPI: pull-down resistor disabled GPO (open drain): pull-up resistor disabled (external pull-up resistor) 1: GPI: pull-down resistor enabled GPO (open drain): pull-up resistor enabled (supply rail selected via GPIOx_TYPE) |
| | 0 | R/W | GPIO8_PUPD | 0: GPI: pull-down resistor disabled GPO (open drain): pull-up resistor disabled (external pull-up resistor) 1: GPI: pull-down resistor enabled GPO (open drain): pull-up resistor enabled (supply rail selected via GPIOx_TYPE) |

Table 199: CONFIG_M

| Register Address | Bit | Type | Label | Description |
|-------------------|-----|------|-----------------|--|
| 0x112 CONFIG_M | 7:4 | R/W | OSC_FRQ | Offset for internal HF oscillator frequency 0x8: -10.67% ... 0xF: -1.33% 0x0: 0.00% 0x1: 1.33% ... 0x7: 9.33% |
| | 3:0 | R/W | Reserved | |

Table 200: Reserved

| Register Address | Bit | Type | Label | Description |
|------------------|-----|------|-----------------|-------------|
| 0x113 | 7:0 | R/W | Reserved | |

System PMIC for Mobile and Automotive Applications

Table 201: MON_REG_1

| Register Address | Bit | Type | Label | Description |
|--------------------|-----|------|-------------------|---|
| 0x114 MON_REG_1 | 7:6 | R/W | UVOV_DELAY | Range comparison is enabled after regulator enable: 00: immediately 01: with one measurement delay 10: with two measurements delay 11: with four measurements delay |
| | 5:4 | R/W | MON_MODE | Regulator monitor executes 00: Under-voltage/Over-voltage lockout with an E_REG_UVOV event (nIRQ assertion) and regulator shutdown from an output voltage being out of the selected range 01: Normal auto measurement with an E_REG_UVOV event (nIRQ assertion) from any finished auto measurement on A8, A9 and A10 10: Burst auto measurement with an E_REG_UVOV event (nIRQ assertion) generated after the time slot of A10 has been processed 11: reserved |
| | 3 | R/W | MON_DEB | 0: Regulator monitor (A8, 9, 10): debouncing off 1: Regulator monitor (A8, 9, 10): debouncing on |
| | 2 | R/W | MON_RES | Control requires M_REG_UVOV = 1: 1: Enables assertion of nRESET from out-of-range detection Note: It is not recommended to assert this control inside OTP |
| | 1:0 | R/W | MON_THRES | Regulator Monitor Threshold 00: Approx = 25 % 01: Approx = 12.5 % 10: Approx = 6.25 % 11: Approx = 3.125 % |

Table 202: MON_REG_2

| Register Address | Bit | Type | Label | Description |
|--------------------|-----|------|--------------------|----------------------------------|
| 0x115 MON_REG_2 | 7 | R/W | LDO8_MON_EN | Enable LDO8 regulator monitoring |
| | 6 | R/W | LDO7_MON_EN | Enable LDO7 regulator monitoring |
| | 5:3 | R/W | Reserved | |
| | 2 | R/W | LDO3_MON_EN | Enable LDO3 regulator monitoring |
| | 1:0 | R/W | Reserved | |

System PMIC for Mobile and Automotive Applications

Table 203: MON_REG_3

| Register Address | Bit | Type | Label | Description |
|--------------------|-----|------|--------------|-----------------------------------|
| 0x116 MON_REG_3 | 7:3 | R/W | Reserved | |
| | 2 | R/W | LDO11_MON_EN | Enable LDO11 regulator monitoring |
| | 1 | R/W | Reserved | |
| | 0 | R/W | LDO9_MON_EN | Enable LDO9 regulator monitoring |

Table 204: MON_REG_4

| Register Address | Bit | Type | Label | Description |
|--------------------|-----|------|---------------|---------------------------------------|
| 0x117 MON_REG_4 | 7 | R/W | BPERI_MON_EN | Enable BUCKPERI regulator monitoring |
| | 6 | R/W | BMEM_MON_EN | Enable BUCKMEM regulator monitoring |
| | 5 | R/W | BIO_MON_EN | Enable BUCKIO regulator monitoring |
| | 4 | R/W | BPRO_MON_EN | Enable BUCKPRO regulator monitoring |
| | 3 | R/W | BCORE2_MON_EN | Enable BUCKCORE2 regulator monitoring |
| | 2 | R/W | BCORE1_MON_EN | Enable BUCKCORE1 regulator monitoring |
| | 1:0 | R/W | Reserved | |

Table 205: MON_REG_5

| Register Address | Bit | Type | Label | Description |
|--------------------|-----|------|------------|---|
| 0x11E MON_REG_5 | 7 | R | Reserved | |
| | 6:4 | R | MON_A9_IDX | Latest measurement at channel A9 was: 000: none 001: BUCKIO 010: BUCKMEM 011: BUCKPERI > 011: reserved |
| | 3 | R | Reserved | |
| | 2:0 | R | MON_A8_IDX | Latest measurement at channel A8 was: 000: none 001: BUCKCORE1 010: BUCKCORE2 011: BUCKPRO 100: LDO3 101: Reserved 110: LDO11 > 110: reserved |

Table 206: MON_REG_6

| Register Address | Bit | Type | Label | Description |
|--------------------|-----|------|-------------|--|
| 0x11F MON_REG_6 | 7:3 | R | Reserved | |
| | 2:0 | R | MON_A10_IDX | Latest measurement at channel A10 was: |

System PMIC for Mobile and Automotive Applications

| Register Address | Bit | Type | Label | Description |
|------------------|-----|------|-------|--|
| | | | | 000: none 001: Reserved 010: LDO7 011: LDO8 100: LDO9 > 100: reserved |

Table 207: Reserved

| Register Address | Bit | Type | Label | Description |
|------------------|-----|------|----------|-------------|
| 0x120 | 7:0 | R/W | Reserved | |

Table 208: GP_ID_0

| Register Address | Bit | Type | Label | Description |
|------------------|-----|-------------------------------|-------------|----------------------------|
| 0x121 GP_ID_0 | 7:0 | R/W Note 1 | GP_0 | Data from fuse array (OTP) |

Note 1 Write access can be disabled by OTP if required.

Table 209: GP_ID_1

| Register Address | Bit | Type | Label | Description |
|------------------|-----|-------------------------------|-------------|----------------------------|
| 0x122 GP_ID_1 | 7:0 | R/W Note 1 | GP_1 | Data from fuse array (OTP) |

Note 1 Write access can be disabled by OTP if required.

Table 210: GP_ID_2

| Register Address | Bit | Type | Label | Description |
|------------------|-----|-------------------------------|-------------|----------------------------|
| 0x123 GP_ID_2 | 7:0 | R/W Note 1 | GP_2 | Data from fuse array (OTP) |

Note 1 Write access can be disabled by OTP if required.

Table 211: GP_ID_3

| Register Address | Bit | Type | Label | Description |
|------------------|-----|-------------------------------|-------------|----------------------------|
| 0x124 GP_ID_3 | 7:0 | R/W Note 1 | GP_3 | Data from fuse array (OTP) |

Note 1 Write access can be disabled by OTP if required.

Table 212: GP_ID_4

| Register Address | Bit | Type | Label | Description |
|------------------|-----|------|-------------|----------------------------|
| 0x125 GP_ID_4 | 7:0 | R/W | GP_4 | Data from fuse array (OTP) |

System PMIC for Mobile and Automotive Applications

| Register Address | Bit | Type | Label | Description |
|------------------|-----|--------|-------|-------------|
| | | Note 1 | | |

Note 1 Write access can be disabled by OTP if required.

Table 213: GP_ID_5

| Register Address | Bit | Type | Label | Description |
|------------------|-----|---------------|-------|----------------------------|
| 0x126 GP_ID_5 | 7:0 | R/W Note 1 | GP_5 | Data from fuse array (OTP) |

Note 1 Write access can be disabled by OTP if required.

Table 214: GP_ID_6

| Register Address | Bit | Type | Label | Description |
|------------------|-----|---------------|-------|----------------------------|
| 0x127 GP_ID_6 | 7:0 | R/W Note 1 | GP_6 | Data from fuse array (OTP) |

Note 1 Write access can be disabled by OTP if required.

Table 215: GP_ID_7

| Register Address | Bit | Type | Label | Description |
|------------------|-----|---------------|-------|----------------------------|
| 0x128 GP_ID_7 | 7:0 | R/W Note 1 | GP_7 | Data from fuse array (OTP) |

Note 1 Write access can be disabled by OTP if required.

Table 216: GP_ID_8

| Register Address | Bit | Type | Label | Description |
|------------------|-----|---------------|-------|----------------------------|
| 0x129 GP_ID_8 | 7:0 | R/W Note 1 | GP_8 | Data from fuse array (OTP) |

Note 1 Write access can be disabled by OTP if required.

Table 217: GP_ID_9

| Register Address | Bit | Type | Label | Description |
|------------------|-----|---------------|-------|----------------------------|
| 0x12A GP_ID_9 | 7:0 | R/W Note 1 | GP_9 | Data from fuse array (OTP) |

Note 1 Write access can be disabled by OTP if required.

Table 218: GP_ID_10

| Register Address | Bit | Type | Label | Description |
|-------------------|-----|------|-------|--|
| 0x12B GP_ID_10 | 7:0 | R/W | GP_10 | Data from fuse array (OTP), no OTP reload after powering up from NO-POWER mode |

System PMIC for Mobile and Automotive Applications

Table 219: GP_ID_11

| Register Address | Bit | Type | Label | Description |
|-------------------|-----|------|-------|----------------------------|
| 0x12C GP_ID_11 | 7:0 | R/W | GP_11 | Data from fuse array (OTP) |

Table 220: Reserved

| Register Address | Bit | Type | Label | Description |
|---------------------------|-----|------|----------|-------------|
| 0x12D – 0x134 Reserved | 7:0 | R | Reserved | Reserved |

Table 221: CoPMIC_S to CoPMIC_E

| Register Address | Bit | Type | Label | Description |
|-------------------|-----|------|----------|----------------------|
| 0x140 CoPMIC_S | 7:0 | R | Reserved | Reserved for Co-PMIC |
| 0x14F CoPMIC_E | 7:0 | R | Reserved | Reserved for Co-PMIC |

Table 222: CHG_Co_S to CHG_Co_E

| Register Address | Bit | Type | Label | Description |
|-------------------|-----|------|----------|--------------------------------|
| 0x150 CHG_Co_S | 7:0 | R | Reserved | Reserved for companion charger |
| 0x17F CHG_Co_E | 7:0 | R | Reserved | Reserved for companion charger |

A.5 Register Page 3

Table 223: PAGE_CON

| Register Address | Bit | Type | Label | Description |
|-------------------|-----|------|------------|---|
| 0x180 PAGE_CON | 7 | RW | REVERT | See register 0x00, Table 43 |
| | 6 | RW | WRITE_MODE | |
| | 5:3 | RW | Reserved | |
| | 2:0 | RW | REG_PAGE | |

Table 224: DEVICE_ID

| Register Address | Bit | Type | Label | Description |
|--------------------|-----|------|-----------|----------------------|
| 0x181 DEVICE_ID | 7:0 | R | DEVICE_ID | Read back of chip ID |

Table 225: VARIANT_ID

| Register Address | Bit | Type | Label | Description |
|------------------|-----|------|-------|---------------------------------------|
| | 7:4 | R | MRC | Read back of mask revision code (MRC) |

System PMIC for Mobile and Automotive Applications

| Register Address | Bit | Type | Label | Description |
|---------------------|-----|------|------------|---|
| 0x182 VARIANT_ID | 3:0 | R | VRC | Read back of package variant code (VRC) |

Table 226: CUSTOMER_ID

| Register Address | Bit | Type | Label | Description |
|----------------------|-----|------|--------------------|---|
| 0x183 CUSTOMER_ID | 7:0 | R | CUSTOMER_ID | ID for customer and target application platform, written during production of variant |

Table 227: CONFIG_ID

| Register Address | Bit | Type | Label | Description |
|--------------------|-----|------|-------------------|--|
| 0x184 CONFIG_ID | 7:0 | R | CONFIG_REV | ID for revision of OTP settings, written during production of variant 00000000 – OTP unprogrammed (RESERVED) > 00000000 – OTP configuration revision xxx |

Table 228: PMIC_STATUS

| Register Address | Bit | Type | Label | Description |
|----------------------|-----|------|-----------------|--|
| 0x1A8 PMIC_STATUS | 7 | R | PC_DONE | Power Commander download complete |
| | 6:5 | R/W | Reserved | |
| | 4:0 | R | STATUS | Decimal Decode: 03 = RESET (Shutdown) 28 = SYSTEM 25 = POWER 23 = POWER-DOWN 20 = POWER1 17 = ACTIVE |

System PMIC for Mobile and Automotive Applications

Status Definitions

| Revision | Datasheet Status | Product Status | Definition |
|----------|------------------|----------------|--|
| 1.<n> | Target | Development | This datasheet contains the design specifications for product development. Specifications may be changed in any manner without notice. |
| 2.<n> | Preliminary | Qualification | This datasheet contains the specifications and preliminary characterization data for products in pre-production. Specifications may be changed at any time without notice in order to improve the design. |
| 3.<n> | Final | Production | This datasheet contains the final specifications for products in volume production. The specifications may be changed at any time in order to improve the design, manufacturing and supply. Major specification changes are communicated via Customer Product Notifications. Datasheet changes are communicated via www.dialog-semiconductor.com . |
| 4.<n> | Obsolete | Archived | This datasheet contains the specifications for discontinued products. The information is provided for reference only. |

RoHS Compliance

Dialog Semiconductor's suppliers certify that its products are in compliance with the requirements of Directive 2011/65/EU of the European Parliament on the restriction of the use of certain hazardous substances in electrical and electronic equipment. RoHS certificates from our suppliers are available on request.

IMPORTANT NOTICE AND DISCLAIMER

RENESAS ELECTRONICS CORPORATION AND ITS SUBSIDIARIES (“RENESAS”) PROVIDES TECHNICAL SPECIFICATIONS AND RELIABILITY DATA (INCLUDING DATASHEETS), DESIGN RESOURCES (INCLUDING REFERENCE DESIGNS), APPLICATION OR OTHER DESIGN ADVICE, WEB TOOLS, SAFETY INFORMATION, AND OTHER RESOURCES “AS IS” AND WITH ALL FAULTS, AND DISCLAIMS ALL WARRANTIES, EXPRESS OR IMPLIED, INCLUDING, WITHOUT LIMITATION, ANY IMPLIED WARRANTIES OF MERCHANTABILITY, FITNESS FOR A PARTICULAR PURPOSE, OR NON-INFRINGEMENT OF THIRD-PARTY INTELLECTUAL PROPERTY RIGHTS.

These resources are intended for developers who are designing with Renesas products. You are solely responsible for (1) selecting the appropriate products for your application, (2) designing, validating, and testing your application, and (3) ensuring your application meets applicable standards, and any other safety, security, or other requirements. These resources are subject to change without notice. Renesas grants you permission to use these resources only to develop an application that uses Renesas products. Other reproduction or use of these resources is strictly prohibited. No license is granted to any other Renesas intellectual property or to any third-party intellectual property. Renesas disclaims responsibility for, and you will fully indemnify Renesas and its representatives against, any claims, damages, costs, losses, or liabilities arising from your use of these resources. Renesas' products are provided only subject to Renesas' Terms and Conditions of Sale or other applicable terms agreed to in writing. No use of any Renesas resources expands or otherwise alters any applicable warranties or warranty disclaimers for these products.

(Disclaimer Rev.1.01 Jan 2024)

Corporate Headquarters

TOYOSU FORESIA, 3-2-24 Toyosu,
Koto-ku, Tokyo 135-0061, Japan
www.renesas.com

Trademarks

Renesas and the Renesas logo are trademarks of Renesas Electronics Corporation. All trademarks and registered trademarks are the property of their respective owners.

Contact Information

For further information on a product, technology, the most up-to-date version of a document, or your nearest sales office, please visit www.renesas.com/contact-us/.

Notice

1. Descriptions of circuits, software and other related information in this document are provided only to illustrate the operation of semiconductor products and application examples. You are fully responsible for the incorporation or any other use of the circuits, software, and information in the design of your product or system. Renesas Electronics disclaims any and all liability for any losses and damages incurred by you or third parties arising from the use of these circuits, software, or information.
2. Renesas Electronics hereby expressly disclaims any warranties against and liability for infringement or any other claims involving patents, copyrights, or other intellectual property rights of third parties, by or arising from the use of Renesas Electronics products or technical information described in this document, including but not limited to, the product data, drawings, charts, programs, algorithms, and application examples.
3. No license, express, implied or otherwise, is granted hereby under any patents, copyrights or other intellectual property rights of Renesas Electronics or others.
4. You shall be responsible for determining what licenses are required from any third parties, and obtaining such licenses for the lawful import, export, manufacture, sales, utilization, distribution or other disposal of any products incorporating Renesas Electronics products, if required.
5. You shall not alter, modify, copy, or reverse engineer any Renesas Electronics product, whether in whole or in part. Renesas Electronics disclaims any and all liability for any losses or damages incurred by you or third parties arising from such alteration, modification, copying or reverse engineering.
6. Renesas Electronics products are classified according to the following two quality grades: "Standard" and "High Quality". The intended applications for each Renesas Electronics product depends on the product's quality grade, as indicated below.

"Standard": Computers; office equipment; communications equipment; test and measurement equipment; audio and visual equipment; home electronic appliances; machine tools; personal electronic equipment; industrial robots; etc.

"High Quality": Transportation equipment (automobiles, trains, ships, etc.); traffic control (traffic lights); large-scale communication equipment; key financial terminal systems; safety control equipment; etc.

Unless expressly designated as a high reliability product or a product for harsh environments in a Renesas Electronics data sheet or other Renesas Electronics document, Renesas Electronics products are not intended or authorized for use in products or systems that may pose a direct threat to human life or bodily injury (artificial life support devices or systems; surgical implantations; etc.), or may cause serious property damage (space system; undersea repeaters; nuclear power control systems; aircraft control systems; key plant systems; military equipment; etc.). Renesas Electronics disclaims any and all liability for any damages or losses incurred by you or any third parties arising from the use of any Renesas Electronics product that is inconsistent with any Renesas Electronics data sheet, user's manual or other Renesas Electronics document.
7. No semiconductor product is absolutely secure. Notwithstanding any security measures or features that may be implemented in Renesas Electronics hardware or software products, Renesas Electronics shall have absolutely no liability arising out of any vulnerability or security breach, including but not limited to any unauthorized access to or use of a Renesas Electronics product or a system that uses a Renesas Electronics product. RENESAS ELECTRONICS DOES NOT WARRANT OR GUARANTEE THAT RENESAS ELECTRONICS PRODUCTS, OR ANY SYSTEMS CREATED USING RENESAS ELECTRONICS PRODUCTS WILL BE INVULNERABLE OR FREE FROM CORRUPTION, ATTACK, VIRUSES, INTERFERENCE, HACKING, DATA LOSS OR THEFT, OR OTHER SECURITY INTRUSION ("Vulnerability Issues"). RENESAS ELECTRONICS DISCLAIMS ANY AND ALL RESPONSIBILITY OR LIABILITY ARISING FROM OR RELATED TO ANY VULNERABILITY ISSUES. FURTHERMORE, TO THE EXTENT PERMITTED BY APPLICABLE LAW, RENESAS ELECTRONICS DISCLAIMS ANY AND ALL WARRANTIES, EXPRESS OR IMPLIED, WITH RESPECT TO THIS DOCUMENT AND ANY RELATED OR ACCOMPANYING SOFTWARE OR HARDWARE, INCLUDING BUT NOT LIMITED TO THE IMPLIED WARRANTIES OF MERCHANTABILITY, OR FITNESS FOR A PARTICULAR PURPOSE.
8. When using Renesas Electronics products, refer to the latest product information (data sheets, user's manuals, application notes, "General Notes for Handling and Using Semiconductor Devices" in the reliability handbook, etc.), and ensure that usage conditions are within the ranges specified by Renesas Electronics with respect to maximum ratings, operating power supply voltage range, heat dissipation characteristics, installation, etc. Renesas Electronics disclaims any and all liability for any malfunctions, failure or accident arising out of the use of Renesas Electronics products outside of such specified ranges.
9. Although Renesas Electronics endeavors to improve the quality and reliability of Renesas Electronics products, semiconductor products have specific characteristics, such as the occurrence of failure at a certain rate and malfunctions under certain use conditions. Unless designated as a high reliability product or a product for harsh environments in a Renesas Electronics data sheet or other Renesas Electronics document, Renesas Electronics products are not subject to radiation resistance design. You are responsible for implementing safety measures to guard against the possibility of bodily injury, injury or damage caused by fire, and/or danger to the public in the event of a failure or malfunction of Renesas Electronics products, such as safety design for hardware and software, including but not limited to redundancy, fire control and malfunction prevention, appropriate treatment for aging degradation or any other appropriate measures. Because the evaluation of microcomputer software alone is very difficult and impractical, you are responsible for evaluating the safety of the final products or systems manufactured by you.
10. Please contact a Renesas Electronics sales office for details as to environmental matters such as the environmental compatibility of each Renesas Electronics product. You are responsible for carefully and sufficiently investigating applicable laws and regulations that regulate the inclusion or use of controlled substances, including without limitation, the EU RoHS Directive, and using Renesas Electronics products in compliance with all these applicable laws and regulations. Renesas Electronics disclaims any and all liability for damages or losses occurring as a result of your noncompliance with applicable laws and regulations.
11. Renesas Electronics products and technologies shall not be used for or incorporated into any products or systems whose manufacture, use, or sale is prohibited under any applicable domestic or foreign laws or regulations. You shall comply with any applicable export control laws and regulations promulgated and administered by the governments of any countries asserting jurisdiction over the parties or transactions.
12. It is the responsibility of the buyer or distributor of Renesas Electronics products, or any other party who distributes, disposes of, or otherwise sells or transfers the product to a third party, to notify such third party in advance of the contents and conditions set forth in this document.
13. This document shall not be reprinted, reproduced or duplicated in any form, in whole or in part, without prior written consent of Renesas Electronics.
14. Please contact a Renesas Electronics sales office if you have any questions regarding the information contained in this document or Renesas Electronics products.

(Note1) "Renesas Electronics" as used in this document means Renesas Electronics Corporation and also includes its directly or indirectly controlled subsidiaries.

(Note2) "Renesas Electronics product(s)" means any product developed or manufactured by or for Renesas Electronics.

(Disclaimer Rev.5.0-1 October 2020)

Corporate Headquarters

TOYOSU FORESIA, 3-2-24 Toyosu,
Koto-ku, Tokyo 135-0061, Japan
www.renesas.com

Trademarks

Renesas and the Renesas logo are trademarks of Renesas Electronics Corporation. All trademarks and registered trademarks are the property of their respective owners.

Contact Information

For further information on a product, technology, the most up-to-date version of a document, or your nearest sales office, please visit:
www.renesas.com/contact/