

Multi-Phase 5A/Phase DC-DC Buck Converter

General Description

DA9213, DA9214, and DA9215 are PMUs optimized for the supply of CPUs, GPUs, and DDR memory rails in smartphones, tablets and other portable applications. The fast transient response (10 A/ μ s) and load regulation are optimized for the latest generation of multi core application processors.

DA9213 operates as a single four-phase buck converter delivering up to 20 A output current.

DA9214 integrates two dual-phase buck converters, capable of delivering 2 x10 A output current.

DA9215 integrates a three-phase buck converter capable of delivering 15 A and a single-phase buck converter delivering 5 A output current.

Each buck regulates a programmable output voltage in the range 0.3 to 1.57 V. With an external resistor divider the output voltage can be set to any voltage between 1.57 V and 4.3 V. The input voltage range of 2.8 to 5.5 V makes it suited for a wide variety of low voltage systems, including all Li-Ion battery powered applications.

To guarantee the highest accuracy and to support multiple PCB routing scenarios without loss of performance, a remote sensing capability is implemented in DA9213, DA9214, and DA9215.

The power devices are fully integrated, so no external FETs or Schottky diodes are needed.

A programmable soft start-up can be enabled, which limits the inrush current from the input node and secures a slope controlled activation of the rail.

The Dynamic Voltage Control (DVC) supports adaptive adjustment of the supply voltage depending on the processor load, either via direct register writes through the communication interface (I²C or SPI compatible) or via an input pin.

DA9213, DA9214, and DA9215 feature integrated over-temperature and over-current protection for increased system reliability without the need for external sensing components. The safety feature set is completed by a VDDIO under-voltage lockout.

The configurable I²C address selection via GPI allows multiple instances of DA9213, DA9214, and DA9215 or both to be placed in the application sharing the same communication interface with different addresses.

Key Features

- 2.8 V to 5.5 V input voltage
- 0.3 V to 1.57 V output voltage
- 1.57 to 4.3 V with resistor divider
- 20 A DA9213
- 2 x 10 A DA9214
- 1 x 15 A + 1x 5 A DA9215
- 3 MHz nominal switching frequency (allows use of low profile [1 mm] inductors)
- ± 1 % accuracy (static)
- ± 3 % accuracy (dynamic)
- Dynamic Voltage Control (DVC)
- Automatic phase shedding
- Integrated power switches
- Remote sensing at point of load
- I²C/SPI compatible interface
- Adjustable soft start
- -40 to +85 °C temperature range
- Package 66 WL-CSP 0.4 mm pitch or 66 VFBGA 0.5 mm pitch

Multi-Phase 5A/Phase DC-DC Buck Converter

Applications

- TV/media players
- Smartphones
- Tablet PCs
- Ultrabooks
- Mobile computing

System Diagrams

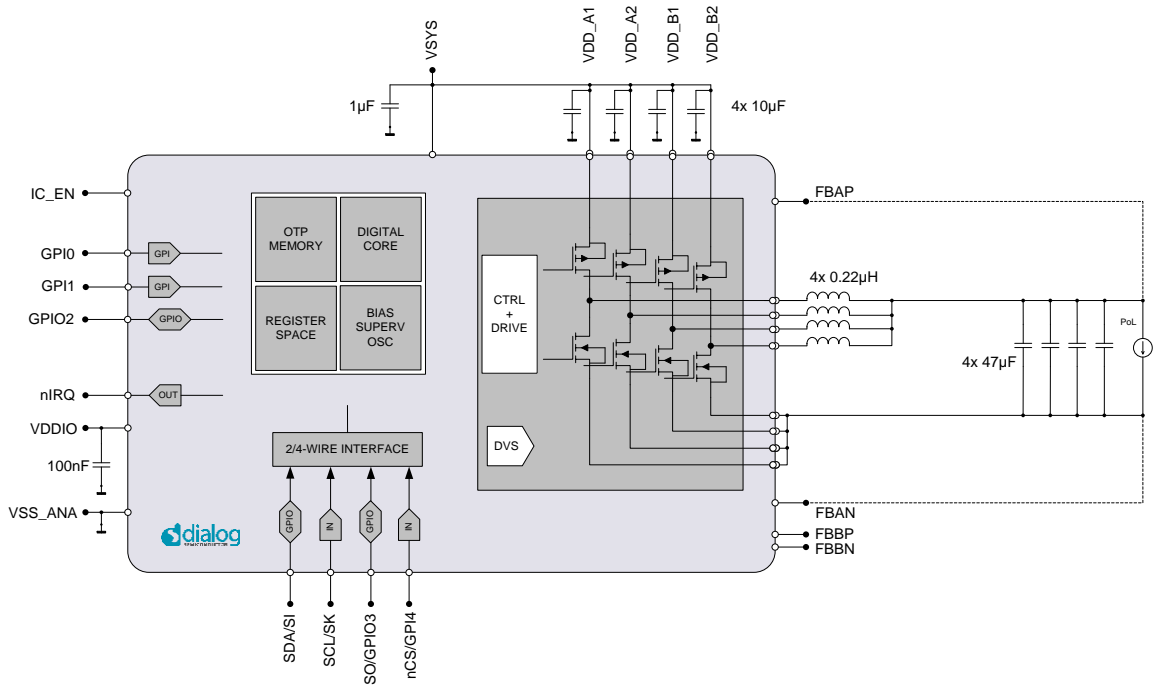

Figure 1: DA9213 System Diagram

Multi-Phase 5A/Phase DC-DC Buck Converter

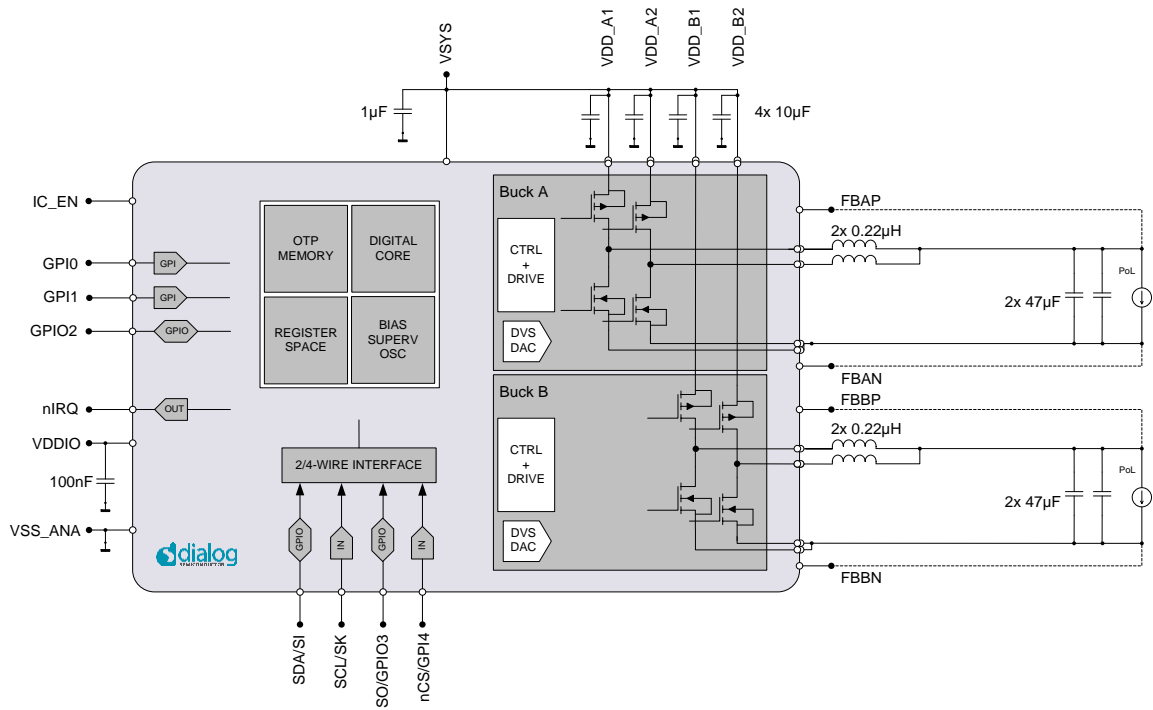

Figure 2: DA9214 System Diagram

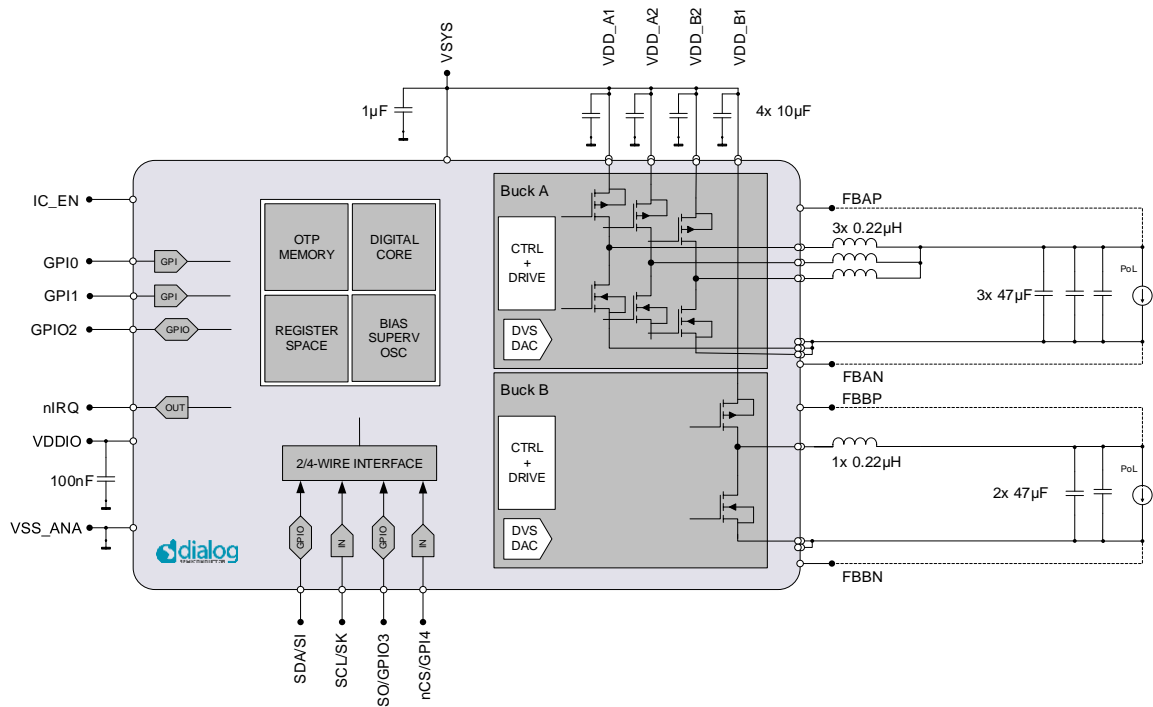

Figure 3: DA9215 System Diagram

Multi-Phase 5A/Phase DC-DC Buck Converter

Contents

General Description	1
Key Features	1
Applications	2
System Diagrams	2
Contents	4
Figures	5
Tables	5
1 Terms and Definitions	7
2 Pinout	8
3 Absolute Maximum Ratings	12
4 Recommended Operating Conditions	12
5 Electrical Characteristics	13
6 Efficiency Measurements	20
7 Functional Description	21
7.1 DC_DC Buck Converter	23
7.1.1 Switching Frequency	25
7.1.2 Operation Modes and Phase Selection	25
7.1.3 Output Voltage Selection	25
7.1.4 Soft Start-Up	26
7.1.5 Current Limit	26
7.1.6 Variable VOUT above 1.57 V	27
7.2 Ports Description	28
7.2.1 VDDIO.....	28
7.2.2 IC_EN	28
7.2.3 nIRQ.....	28
7.2.4 GPIO Extender	29
7.3 Operating Modes.....	31
7.3.1 ON Mode	31
7.3.2 OFF Mode.....	31
7.4 Control Interfaces.....	31
7.4.1 4-WIRE Communication	31
7.4.2 2-WIRE Communication	35
7.4.3 Details of the 2-WIRE Control Bus Protocol	36
7.5 Internal Temperature Supervision.....	39
8 Register Definitions	40
8.1 Register Map.....	40
8.1.1 Register Page Control	42
8.1.2 Register Page 0	42
8.1.2.1 System Control and Event	42
8.1.2.2 GPIO Control	44
8.1.2.3 Regulators Control.....	46

Multi-Phase 5A/Phase DC-DC Buck Converter

8.1.3	Register Page 1	47
8.1.3.1	Regulators Settings	47
8.1.4	Register Page 2	52
8.1.4.1	Interface and OTP Settings (shared with DA9063)	52
8.1.4.2	Application Configuration Settings.....	53
9	Application Information	57
9.1	Capacitor Selection	57
9.2	Inductor Selection	58
10	Package Information	59
10.1	Package Outlines	59
11	Ordering Information	61

Figures

Figure 1:	DA9213 System Diagram.....	2
Figure 2:	DA9214 System Diagram.....	3
Figure 3:	DA9215 System Diagram.....	3
Figure 4:	DA9213/14/15 66 WL-CSP Ball Map	8
Figure 5:	DA9213/14/15 66 VFBGA Ball Map	9
Figure 6:	2-WIRE Bus Timing.....	18
Figure 7:	4-WIRE Bus Timing.....	19
Figure 8:	2 Phase Auto-Mode, 0 to 10 A	20
Figure 9:	2 Phase Auto-Mode, 0 to 10 A	20
Figure 10:	4 Phase Auto-Mode, 0 to 20 A (Linear)	20
Figure 11:	4 Phase Auto-Mode, 0 to 20 A (Logarithmic)	20
Figure 12:	4 Phase Auto-Mode, 0 to 20 A	20
Figure 13:	1, 2, 3, and 4 Phase Modes	20
Figure 14:	Interface of DA9213/14/15 with DA9063 and the Host Processor	21
Figure 15:	Typical Application of DA9213	22
Figure 16:	Typical Application of DA9214	23
Figure 17:	Concept of Control of the Buck's Output Voltage	26
Figure 18:	Resistive Divider from VOUT to FBAN	27
Figure 19:	GPIO Principle of Operation (Example Paths).....	30
Figure 20:	Schematic of 4-WIRE and 2-WIRE Power Manager Bus	32
Figure 21:	4-WIRE Host Write and Read Timing (nCS_POL = 0, CPOL = 0, CPHA = 0)	33
Figure 22:	4-WIRE Host Write and Read Timing (nCS_POL = 0, CPOL = 0, CPHA = 1)	33
Figure 23:	4-WIRE Host Write and Read Timing (nCS_POL = 0, CPOL = 1, CPHA = 0)	34
Figure 24:	4-WIRE Host Write and Read Timing (nCS_POL = 0, CPOL = 1, CPHA = 1)	34
Figure 25:	Timing of 2-WIRE START and STOP Condition.....	36
Figure 26:	2-WIRE Byte Write (SDA Line)	37
Figure 27:	Examples of 2-WIRE Byte Read (SDA Line)	37
Figure 28:	Examples of 2-WIRE Page Read (SDA Line)	37
Figure 29:	2-WIRE Page Write (SDA Line)	38
Figure 30:	2-WIRE Repeated Write (SDA Line)	38
Figure 31:	DA9213/14/15 66 WL-CSP Package Outline Drawing	59
Figure 32:	DA9213/14/15 66 VFBGA Package Outline Drawing	60

Tables

Table 1:	Pin Description	10
Table 2:	Pin Type Definition	11

Multi-Phase 5A/Phase DC-DC Buck Converter

Table 3: Absolute Maximum Ratings.....	12
Table 4: Recommended Operating Conditions (Note 1)	12
Table 5: Buck Converters Characteristics	13
Table 6: IC Performance and Supervision	16
Table 7: Digital I/O Characteristics	16
Table 8: 2-WIRE Control Bus Characteristics	17
Table 9: 4-WIRE Control Bus Characteristics	19
Table 10: 4-WIRE Clock Configurations.....	32
Table 11: 4-WIRE Interface Summary	35
Table 12: Over-Temperature Thresholds	39
Table 13: Register Map	41
Table 14: Recommended Capacitor Types.....	57
Table 15: Recommended Inductor Types	58
Table 16: Ordering Information	61

Multi-Phase 5A/Phase DC-DC Buck Converter**1 Terms and Definitions**

AP	Application Processor
CPU	Central Processing Unit
DDR	Double Data Rate (type of SDRAM memory for PCs)
DVC	Dynamic Voltage Control
GPU	Graphic Processing Unit
IC	Integrated Circuit
OTP	One Time Programmable memory
PCB	Printed Circuit Board
PMIC	Power Management Integrated Circuit
POL	Point Of Load
SDRAM	Synchronous Dynamic Random Access Memory

Multi-Phase 5A/Phase DC-DC Buck Converter

2 Pinout

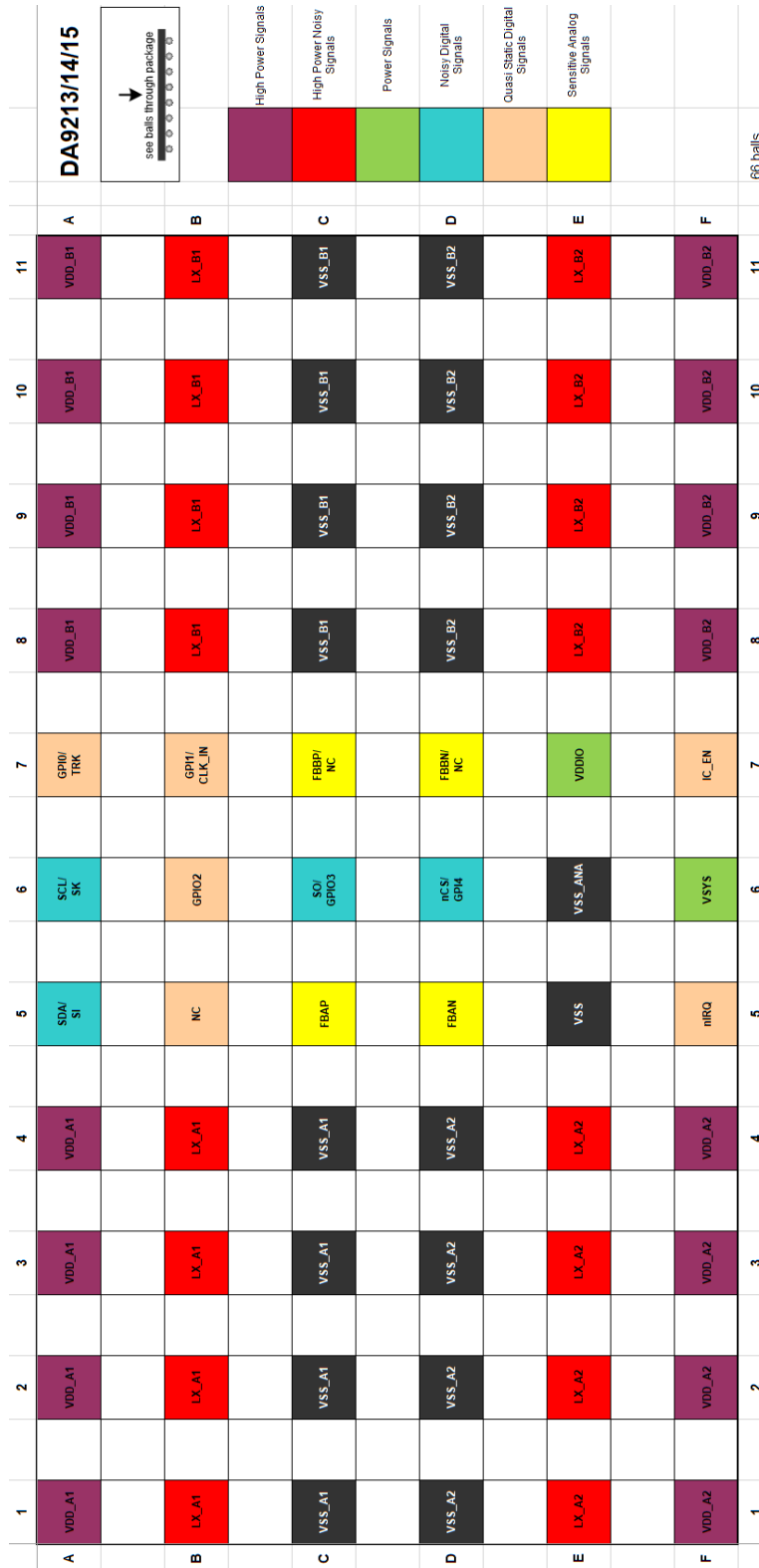

Figure 4: DA9213/14/15 66 WL-CSP Ball Map

Multi-Phase 5A/Phase DC-DC Buck Converter



Figure 5: DA9213/14/15 66 VFBGA Ball Map

Multi-Phase 5A/Phase DC-DC Buck Converter

Table 1: Pin Description

Pin Name	Signal Name	Second Function	Type (Table 2)	Description
B1, B2, B3, B4	LX_A1		AO	Switching node for Buck A phase 1
E1, E2, E3, E4	LX_A2		AO	Switching node for Buck A phase 2
B8, B9, B10, B11	LX_B1		AO	Switching node for Buck B phase 1
E8, E9, E10, E11	LX_B2		AO	Switching node for Buck B phase 2
A1, A2, A3, A4	VDD_A1		PS	Supply voltage for Buck A phase 1 To be connected to VSYS
F1, F2, F3, F4	VDD_A2		PS	Supply voltage for Buck A phase 2 To be connected to VSYS
A8, A9, A10, A11	VDD_B1		PS	Supply voltage for Buck B phase 1 To be connected to VSYS
F8, F9, F10, F11	VDD_B2		PS	Supply voltage for Buck B phase 2 To be connected to VSYS
F7	IC_EN		DI	Integrated Circuit (IC) Enable Signal
F5	nIRQ		DO	Interrupt line towards the host
E7	VDDIO		PS	I/O Voltage Rail
C5	FBAP		AI	Positive sense node for Buck A
D5	FBAN		AI	Negative sense node for Buck A
C7	FBBP		AI	Positive sense node for Buck B of DA9214 or DA9215
	NC		AO	Do not connect for DA9213
D7	FBBN		AI	Negative sense node for Buck B of DA9214 or DA9215
	NC		AO	Do not connect for DA9213
A7	GPIO	TRK	DI/AI	General purpose input, input track
B7	GPIO1		DI	General purpose input
B6	GPIO2		DIO	General purpose input/output
A5	SDA	SI	DIO	2-WIRE data, 4-WIRE data input/output
A6	SCL	SK	DI	2-WIRE clock, 4-WIRE clock
D6	nCS	GPI4	DI	4-WIRE chip select, general purpose input
C6	SO	GPIO3	DIO	4-WIRE data output, general purpose input/output
B5	NC		AO	Do not connect and leave floating. This pin is used for the supply of internal circuits.
	VDDCORE		AO	Regulated supply (typical 2.5 V) for internal circuitry. On VFBGA package, decouple with 150 nF (or 220 nF).
F6	VSYS		PS	Supply for IC and input for voltage supervision
E5	VSS		VSS	
E6	VSS_ANA		VSS	

Multi-Phase 5A/Phase DC-DC Buck Converter

Pin Name	Signal Name	Second Function	Type (Table 2)	Description
C1, C2, C3, C4, D1, D2, D3, D4, C8, C9, C10, C11, D8, D9, D10, D11	VSS_A1, VSS_A2 VSS_B1 VSS_B2		VSS	Connect together

Table 2: Pin Type Definition

Pin Type	Description	Pin Type	Description
DI	Digital Input	AI	Analog Input
DO	Digital Output	AO	Analog Output
DIO	Digital Input/Output	AIO	Analog Input/Output
PS	Power Supply	VSS	Ground

Multi-Phase 5A/Phase DC-DC Buck Converter

3 Absolute Maximum Ratings

Table 3: Absolute Maximum Ratings

Symbol	Parameter	Conditions (Note 1)	Min	Typ	Max	Unit
T _{STG}	Storage temperature		-65		+150	°C
T _J	Junction temperature		-40		+150	°C
V _{DD_LIM}	Limiting supply voltage		-0.3		6.0	V
V _{PIN}	Limiting voltage at all pins except above		-0.3		V _{DD} + 0.3 (max 6.0)	V
V _{ESD_HBM}	Electrostatic discharge voltage	Human Body Model			2	kV

Note 1 Stresses beyond those listed under Absolute Maximum Ratings may cause permanent damage to the device. These are stress ratings only, so functional operation of the device at these or any other conditions beyond those indicated in the operational sections of the specification are not implied. Exposure to absolute maximum rating conditions for extended periods may affect device reliability.

4 Recommended Operating Conditions

Table 4: Recommended Operating Conditions (Note 1)

Parameter	Description	Conditions	Min	Typ	Max	Unit
V _{DD}	Supply voltage		2.8		5.5	V
T _{J_OP}	Operating junction temperature				125	°C
T _A	Ambient temperature		-40		85	°C
V _{DDIO}	Input/output supply voltage		1.2		3.6 Note 2	
P _{TOT}	Total power dissipation Note 3	66 WL-CSP Derating factor above T _A = 70 °C: 37 mW/°C		2035		mW
P _{TOT}	Total power dissipation Note 3	66 VFBGA Derating factor above T _A = 70 °C: 34.8 mW/°C		1920		mW

Note 1 Within the specified limits, a lifetime of 10 years is guaranteed.

Note 2 V_{DDIO} is not allowed to be higher than V_{DD}.

Note 3 Obtained from simulation on a 2S2P 4L JEDEC Board (EIA/JESD51-2). Influenced by PCB technology and layout.

Multi-Phase 5A/Phase DC-DC Buck Converter

5 Electrical Characteristics

Unless otherwise noted, the following is valid for $T_J = -40$ to $+125$ °C, $V_{DD} = 2.8$ V to 5.5 V, $C_{OUT} = 47$ μ F per phase, local sensing.

Table 5: Buck Converters Characteristics

Parameter	Description	Conditions	Min	Typ	Max	Unit
External Component Electrical Conditions						
C_{OUT}	Output capacitance (per phase)	Including voltage and temperature coefficient	23	47	62	μ F
ESR_{COUT}	Equivalent series resistance (per phase)	$f > 100$ kHz			10	m Ω
L_{PHASE}	Inductance (per phase)	Including current and temperature dependence	0.11	0.22	0.29	μ H
DCR_{LPHASE}	Inductor resistance				100	m Ω
Electrical Characteristics						
V_{DD}	Supply voltage	$V_{DD_X} = V_{SYS}$	2.8		5.5	V
V_{BUCK}	Buck output voltage Note 1	$I_O = 0$ to I_{O_MAX}	0.3		1.57	V
V_{OACC}	Output voltage accuracy PWM mode	Incl. static line/load reg and voltage ripple $V_{BUCK} \geq 1$ V	-2.0		+2.0	%
		Incl. static line/load reg and voltage ripple $V_{BUCK} < 1$ V		± 20		mV
		$V_{BUCK} = 1$ V $V_{DD} = 3.8$ V no load	-1.0		+1.0	%
		$V_{BUCK} = 1$ V $V_{DD} = 3.8$ V no load $T_A = 27$ °C	-0.5		+0.5	%
V_{TR_LOAD}	Load regulation transient voltage Note 2	DA9213 $I_O = 0$ to 5 A, $t_R = 500$ ns PWM 4-phase $V_{BUCK} \geq 1$ V $V_{BUCK} < 1$ V				%
			-2		+2	
			-20 mV		+20 mV	
		DA9213 $I_O = 0$ to 5 A, $t_R = 500$ ns auto mode, ph shedding $V_{BUCK} = 1$ V	-3.5		+3.5	%
		DA9214 $I_O = 0$ to 5 A, $t_R = 500$ ns PWM 2-phase $V_{BUCK} = 1$ V		± 3.5		%
DA9215 Buck A		± 2.5		%		

Multi-Phase 5A/Phase DC-DC Buck Converter

Parameter	Description	Conditions	Min	Typ	Max	Unit
		$I_O = 0$ to 5 A, $t_R = 500$ ns PWM 3-phase $V_{BUCK} = 1$ V				
		DA9215 Buck B $I_O = 0$ to 2.5 A, $t_R = 200$ ns PWM, $2 \times 47 \mu\text{F}$ $V_{BUCK} = 1$ V		± 2.5		%
V_{TR_LINE}	Line regulation transient voltage	$V_{DD} = 3.0$ to 3.6 V $dt = 10 \mu\text{s}$ $I_O = I_{O(MAX)}/2$		15		mV
I_{O_MAX}	Maximum output current	Per phase	5000			mA
I_{LIM_MIN}	Minimum current limit per phase (programmable)	BUCKA_ILIM = 0000 BUCKB_ILIM = 0000 Note 3	-20%	4000	20%	mA
I_{LIM_MAX}	Maximum current limit per phase (programmable)	BUCKA_ILIM = 1111 BUCKB_ILIM = 1111 Note 3	-20%	7000	20%	mA
I_{Q_PWM}	Quiescent current at synchronous rectification mode	Per phase No load $V_{DD} = 3.7$ V		17		mA
f_{SW}	Switching frequency			3		MHz
t_{STUP}	Start-up time	$V_{OUT} = 1.0$ V BUCKA_UP_CTRL = 100 BUCKB_UP_CTRL = 100		50 Note 4		μs
R_{O_PD}	Output pull-down resistance	For each phase at the LX node at 0.5 V, (see BUCKx_PD_DIS)		150	200	Ω
R_{ON_PMOS}	PMOS on-resistance	66 WL-CSP incl. pin and routing $V_{DD} = 3.7$ V per phase		26		m Ω
		66 VFBGA incl. pin and routing $V_{DD} = 3.7$ V per phase		27		m Ω
R_{ON_NMOS}	NMOS on-resistance	66 WL-CSP incl. pin and routing $V_{DD} = 3.7$ V per phase		18		m Ω
		66 VFBGA incl. pin and routing $V_{DD} = 3.7$ V per phase		19		m Ω

Multi-Phase 5A/Phase DC-DC Buck Converter

Parameter	Description	Conditions	Min	Typ	Max	Unit
PFM Mode						
V _{BUCK_PFM}	Buck output voltage in PFM	I _O = 0 mA to I _{O_MAX}	0.3		1.57	V
I _{MIN_PFM}	Minimum output current in PFM	Static output voltage, no DVC	2			mA
I _{Q_PFM_A2}	DA9214 quiescent current Buck A enabled	No switching V _{DD} = 3.7 V Note 5		58		μA
I _{Q_PFM_A4}	DA9213 quiescent current Buck enabled	No switching V _{DD} = 3.7 V Note 5		72		μA
I _{Q_PFM_A2B2}	DA9214 quiescent current Buck A enabled Buck B enabled	No switching V _{DD} = 3.7 V Note 5		106		μA
I _{Q_PFM_A3B1}	DA9215 quiescent current Buck A enabled Buck B enabled	No switching V _{DD} = 3.7 V Note 5		130		μA

Note 1 Programmable in 10 mV increments.

Note 2 Additional to the dc accuracy. The value is intended to be measured directly at C_{OUT(EXT)}. In case of remote sensing, parasitics of PCB and external components may affect this value.

Note 3 On-time > 50 ns.

Note 4 Time from beginning to end of the voltage ramp. Additional 10 μs typical delay, plus internal sync to the enable port.

Note 5 For the total quiescent current of the IC, the I_{DD_ON} should be added.

Multi-Phase 5A/Phase DC-DC Buck Converter

Table 6: IC Performance and Supervision

Parameter	Description	Conditions	Min	Typ	Max	Unit
I _{DD_OFF}	Off state supply current	IC_EN = 0 T _A = 27 °C		0.1	1	μA
I _{DD_ON}	On state supply current	IC_EN = 1 Buck A/B off T _A = 27 °C		14		μA
V _{TH_PG}	Power good threshold voltage	referred to V _{BUCK}		-50		mV
V _{HYS_PG}	Power good hysteresis voltage			50		mV
V _{TH_UVLO_VDD}	Under-voltage lockout threshold at V _{DD}	66 WL-CSP		2.0		V
	Under-voltage lockout threshold at V _{DD}	66 VFBGA BUCK_EN = 0		2.0		V
	Under-voltage lockout threshold at V _{DD}	66 VFBGA BUCK_EN = 1		2.55		V
V _{TH_UVLO_IO}	Under-voltage lockout threshold at V _{DDIO}		1.35	1.45	1.55	V
V _{HYS_UVLO_IO}	Under-voltage lockout hysteresis at V _{DDIO}			70		mV
T _{TH_WARN}	Thermal warning threshold temperature		110	125	140	°C
T _{TH_CRIT}	Thermal critical threshold temperature		125	140	155	°C
T _{TH_POR}	Thermal power on reset threshold temperature		135	150	165	°C
f _{OSC}	Internal oscillator frequency		-7%	6.0	+7%	MHz

Table 7: Digital I/O Characteristics

T_A = -40 to +85 °C

Parameter	Description	Conditions	Min	Typ	Max	Unit
V _{IH_EN}	HIGH level input voltage	At pin IC_EN	1.1			V
V _{IL_EN}	LOW level input voltage	At pin IC_EN			0.35	V
t _{EN}	Enable time	I/F operating		750		μs
R _{O_PU_GPO}	Pull up resistor at GPO	V _{DDIO} = 1.8 V V _{GPO} = 0 V		100		kΩ
R _{I_PD_GPI}	Pull down resistor at GPI	V _{DDIO} = 1.8 V V _{GPO} = 0 V		150		kΩ
V _{IH}	GPI0-4, SCL, SDA, (2-WIRE mode) HIGH level input voltage	VDDCORE mode VDDIO mode	1.75 0.7 * V _{DDIO}			V
V _{IL}	GPI0-4, SCL, SDA,	VDDCORE mode			0.75	V

Multi-Phase 5A/Phase DC-DC Buck Converter

Parameter	Description	Conditions	Min	Typ	Max	Unit
	(2-WIRE mode) LOW level input voltage	VDDIO mode			0.3 * V _{DDIO}	
V _{IH_4WIRE}	SK, nCS, SI (4-WIRE Mode) HIGH level input voltage		0.7* V _{DDIO}			V
V _{IL_4WIRE}	SK, nCS, SI (4-WIRE Mode) LOW level input voltage				0.3*V _{DDIO}	V
V _{OH}	GPO2-3, SO (4-WIRE mode) HIGH level output voltage	push-pull mode at 1 mA V _{DDIO} ≥ 1.5 V	0.8*V _{DDIO}			V
V _{OL1}	GPO2-3, SDA (2-WIRE mode) SO (4-WIRE mode) LOW level output voltage at I _{OL} = 1 mA				0.3	V
V _{OL3}	SDA (2-WIRE Mode) LOW level output voltage at I _{OL} = 3 mA				0.24	V
V _{OL20}	SDA (2-WIRE Mode) LOW level output voltage at I _{OL} = 20 mA				0.4	V
C _{IN}	CLK, SDA (2-WIRE Mode) input capacitance			2.5	10	pF
t _{SP}	CLK, SDA (2-WIRE Mode) spike suppression pulse width	Fast/Fast+ mode High Speed mode	0 0		50 10	ns
t _{rDA}	Fall time of SDA signal (2-WIRE Mode)	Fast at C _B < 550 pF HS at 10 < C _B < 100 pF HS at C _B < 400 pF	20+0.1C _B 10 20		120 80 160	ns

Table 8: 2-WIRE Control Bus Characteristics

T_A = -40 to +85 °C

Parameter	Description	Conditions	Min	Typ	Max	Unit
t _{BUF}	Bus free time from STOP to START condition		0.5			μs
C _B	Bus line capacitive load				150	pF
Standard/Fast/Fast+ Mode						
f _{SCL}	Clock frequency	At pin SCL	0 Note 1		1000	kHz
t _{SU_STA}	START condition set-up time		0.26			μs
t _{H_STA}	START condition hold time		0.26			μs

Multi-Phase 5A/Phase DC-DC Buck Converter

Parameter	Description	Conditions	Min	Typ	Max	Unit
t_{W_CL}	Clock LOW duration		0.5			μ s
t_{W_CH}	Clock HIGH duration		0.26			μ s
t_R	Rise time	Input requirement. At pin CLK and DATA			1000	ns
t_F	Fall time	Input requirement. At pin CLK and DATA			300	ns
t_{SU_D}	Data set-up time		50			ns
t_{H_D}	Data hold time		0			ns
High Speed Mode						
f_{SCL_HS}	Clock frequency	At pin SCL	0 Note 1		3400	kHz
$t_{SU_STA_HS}$	START condition set-up time		160			ns
$t_{H_STA_HS}$	START condition hold time		160			ns
$t_{W_CL_HS}$	Clock LOW duration		160			ns
$t_{W_CH_HS}$	Clock HIGH duration		60			ns
t_{R_HS}	Rise time	Input requirement. At pin CLK and DATA			160	ns
t_{F_HS}	Fall time	Input requirement. At pin CLK and DATA			160	ns
$t_{SU_D_HS}$	Data set-up time		10			ns
$t_{H_D_HS}$	Data hold time		0			ns
$t_{SU_STO_HS}$	STOP condition set-up time		160			ns

Note 1 Minimum clock frequency is 10 kHz if 2WIRE_TO is enabled

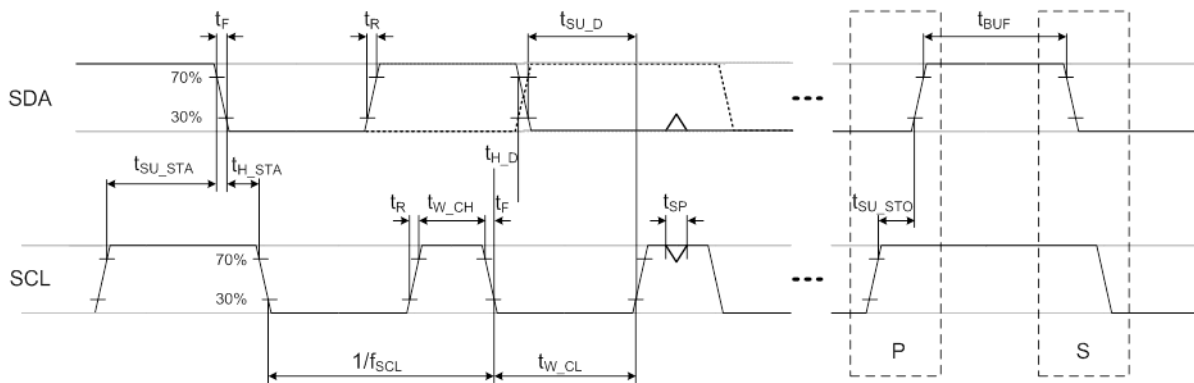

Figure 6: 2-WIRE Bus Timing

Multi-Phase 5A/Phase DC-DC Buck Converter

Table 9: 4-WIRE Control Bus Characteristics

T_A = -40 to +85 °C

Parameter	Description	Conditions	Min	Typ	Max	Unit
C _B	Bus line capacitive load				100	pF
t _c	Cycle time	1	70			ns
t _{SU_CS}	Chip select setup time	2, from CS active to first SK edge	20			ns
t _{H_CS}	Chip select hold time	3, from last SK edge to CS idle	20			ns
t _{W_CL}	Clock LOW duration	4	0.4 x t _c			ns
t _{W_CH}	Clock HIGH duration	5	0.4 x t _c			ns
t _{SU_SI}	Data input setup time	6	10			ns
t _{H_SI}	Data input hold time	7	10			ns
t _{V_SO}	Data output valid time	8			22	ns
t _{H_SO}	Data output hold time	9	6			ns
t _{W_CS}	Chip select HIGH duration	10	20			ns

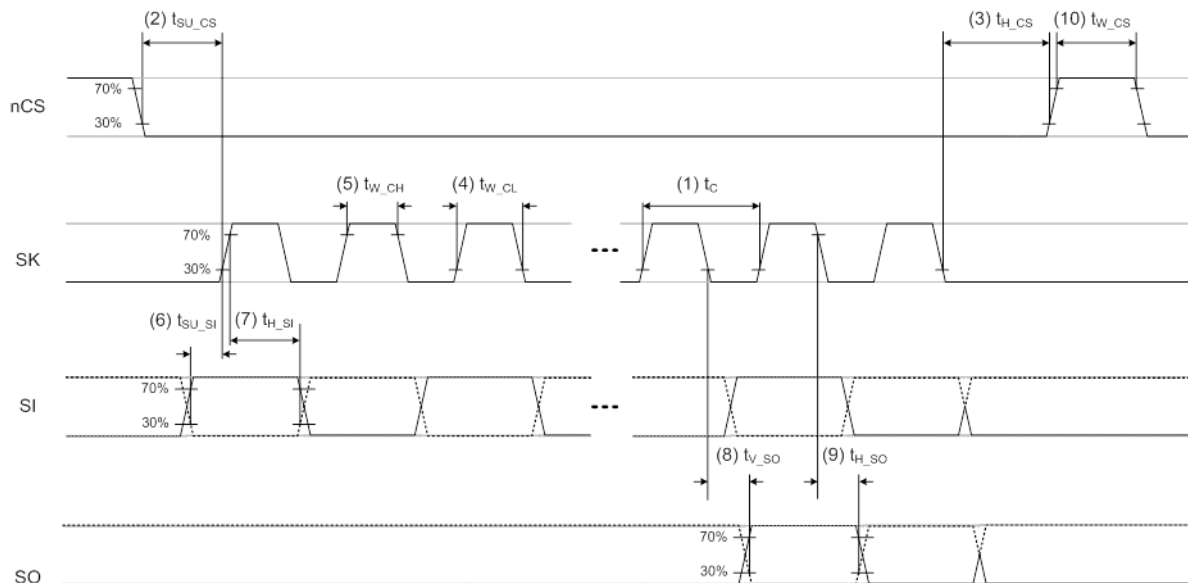

Figure 7: 4-WIRE Bus Timing

Multi-Phase 5A/Phase DC-DC Buck Converter

6 Efficiency Measurements

Note: 66 WL-CSP, phase shedding is enabled.

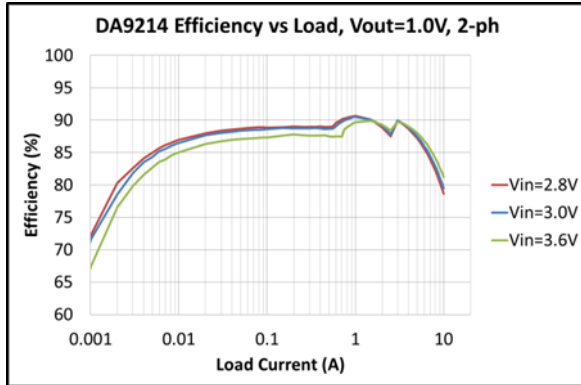

Figure 8: 2 Phase Auto-Mode, 0 to 10 A

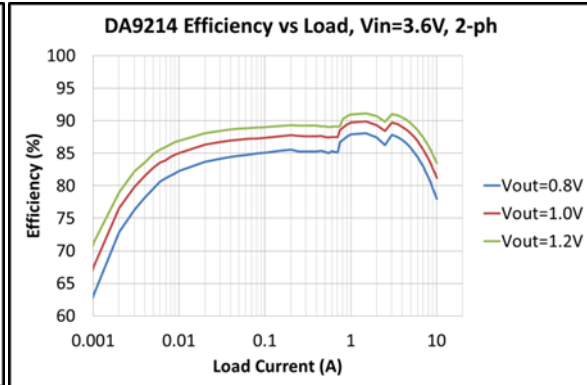

Figure 9: 2 Phase Auto-Mode, 0 to 10 A

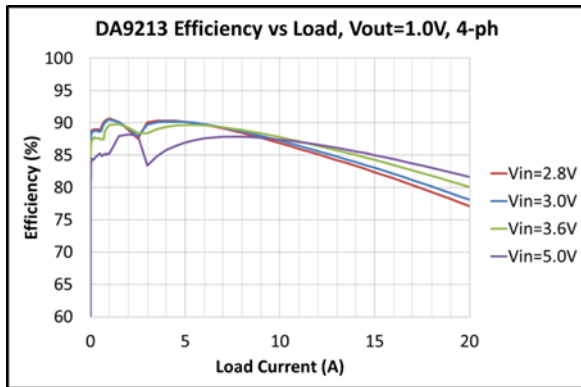

Figure 10: 4 Phase Auto-Mode, 0 to 20 A (Linear)

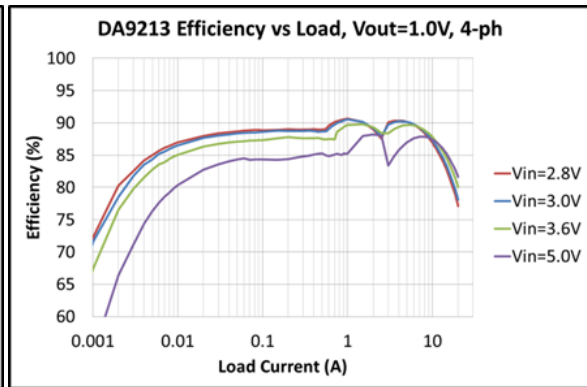

Figure 11: 4 Phase Auto-Mode, 0 to 20 A (Logarithmic)

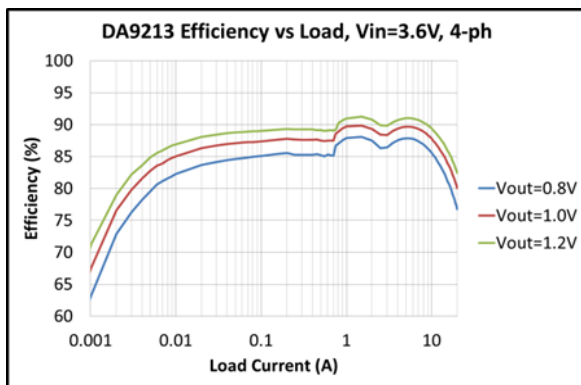

Figure 12: 4 Phase Auto-Mode, 0 to 20 A

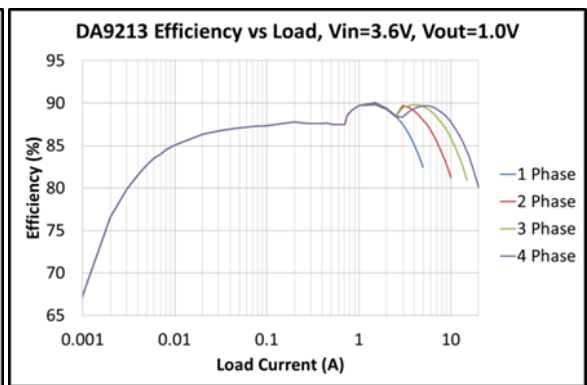

Figure 13: 1, 2, 3, and 4 Phase Modes

Multi-Phase 5A/Phase DC-DC Buck Converter

7 Functional Description

Flexible configurability and the availability of different control schemes make both DA9213, DA9214, and DA9215 the ideal single/dual buck companion ICs to expand the existing capabilities of a master PMIC.

Due to the advanced compatibility between both DA9213, DA9214, and DA9215 and the DA9063, they offer several advantages when they are operated together. These advantages include:

- DA9213, DA9214, and DA9215 can be enabled and controlled by DA9063 during the power up sequence, thanks to DA9063's dedicated output signals during power up, and compatible input controls in both DA9213, DA9214, and DA9215.
- DA9213, DA9214, and DA9215 can be used in a completely transparent way for the host processor and can share the same Control Interface (same SPI chip select or I²C address), thanks to the compatible registers map. DA9213, DA9214, and DA9215 have a dedicated register space for configuration and control which does not conflict with DA9063.
- DA9213, DA9214, and DA9215 support a power good configurable port for enhanced communication to the host processor and improved power up sequencing.
- DA9213, DA9214, and DA9215 can share the same interrupt line with DA9063.

In addition, the 2-WIRE / 4-WIRE interfaces allow DA9213, DA9214, and DA9215 to fit many standard PMU parts and power applications.

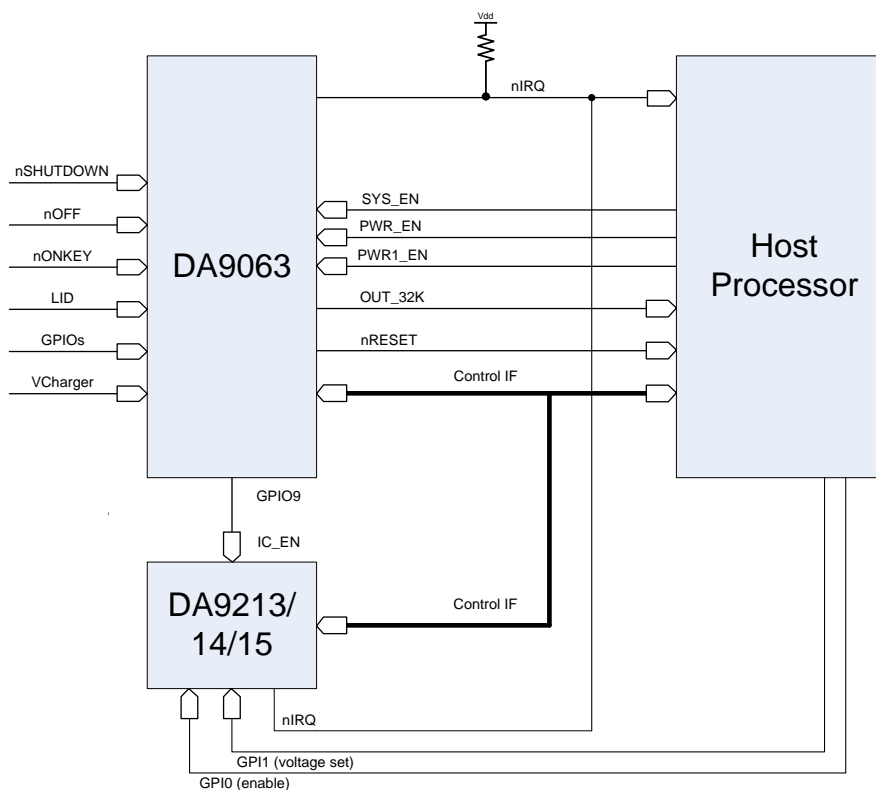

Figure 14: Interface of DA9213/14/15 with DA9063 and the Host Processor

As shown in [Figure 14](#), a typical application case includes a host processor, a Main PMIC (for example, DA9063) and DA9213 or DA9214 or DA9215 used as companion IC for the high power core supply.

The easiest way of controlling DA9213, DA9214, and DA9215 is through the Control Interface. The master initiating the communication must always be the host processor that reads and writes to the main PMIC, and to the DA9213, DA9214, and DA9215 registers. To poll the status of DA9213 or

Multi-Phase 5A/Phase DC-DC Buck Converter

DA9214, the host processor must access the dedicated register area through the Control Interface. DA9213, DA9214, and DA9215 can be additionally controlled by means of hardware inputs.

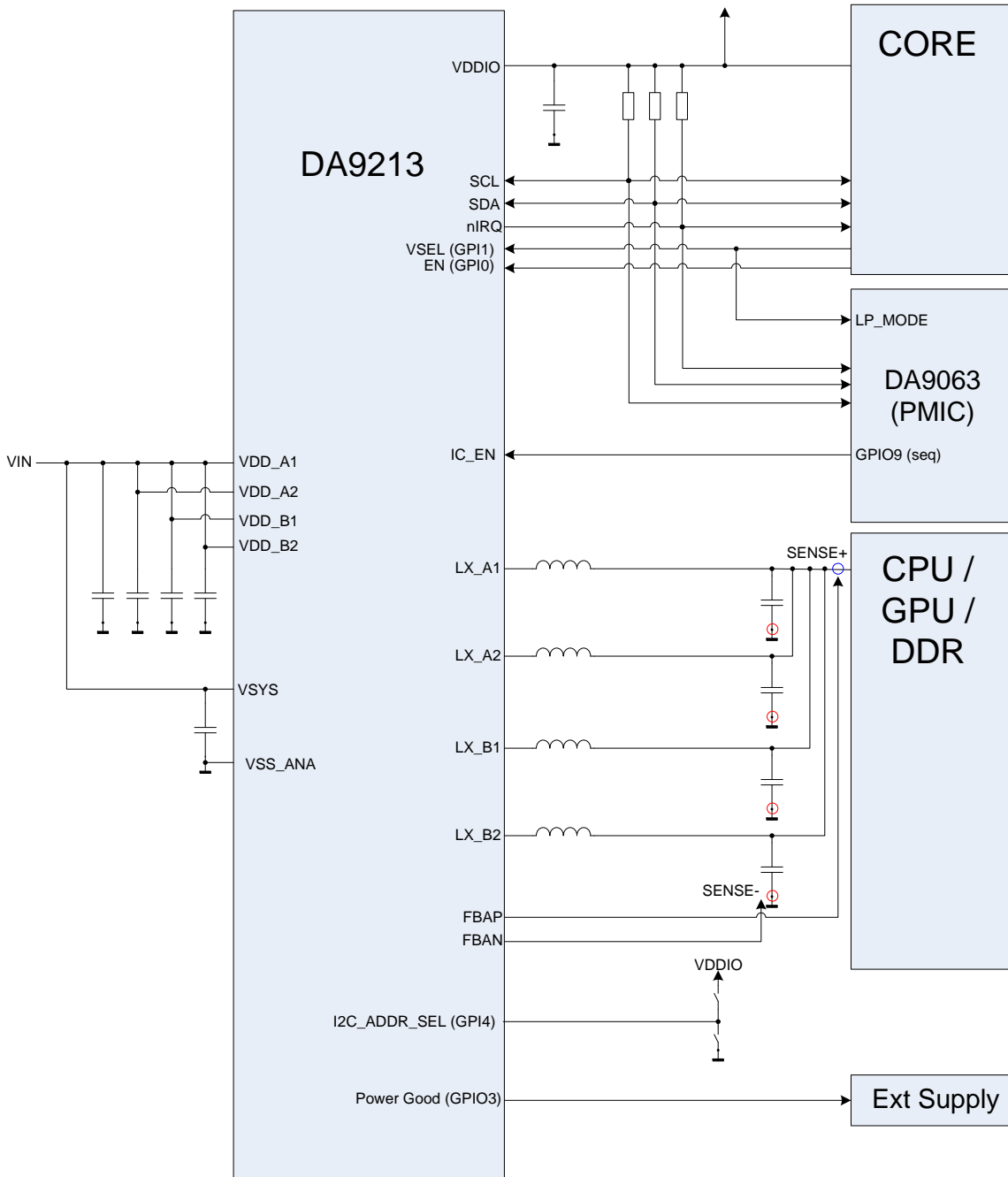

Figure 15: Typical Application of DA9213

Figure 15 shows a typical use case of DA9213 for the supply of CPU, GPU, or DDR rails. The IC is enabled and disabled by the main PMIC via IC_EN port as part of its sequencer. Once the IC is enabled, the CORE application processor enables the buck converter with the EN1 signal and manages the output voltage selection with the VSEL signal.

The VSEL signal can be shared between the main PMIC and the DA9213. Three GPI/GPIOs embedded in DA9213 are used in this case:

Multi-Phase 5A/Phase DC-DC Buck Converter

- GPIO2 signals the insertion of an external charger in the application (through interrupt to the host processor)
- GPIO3 indicates a power good condition, either to proceed with the power up sequence or to enable an external supply connected to the port
- GPI4 is used for the I²C interface address hardware selection

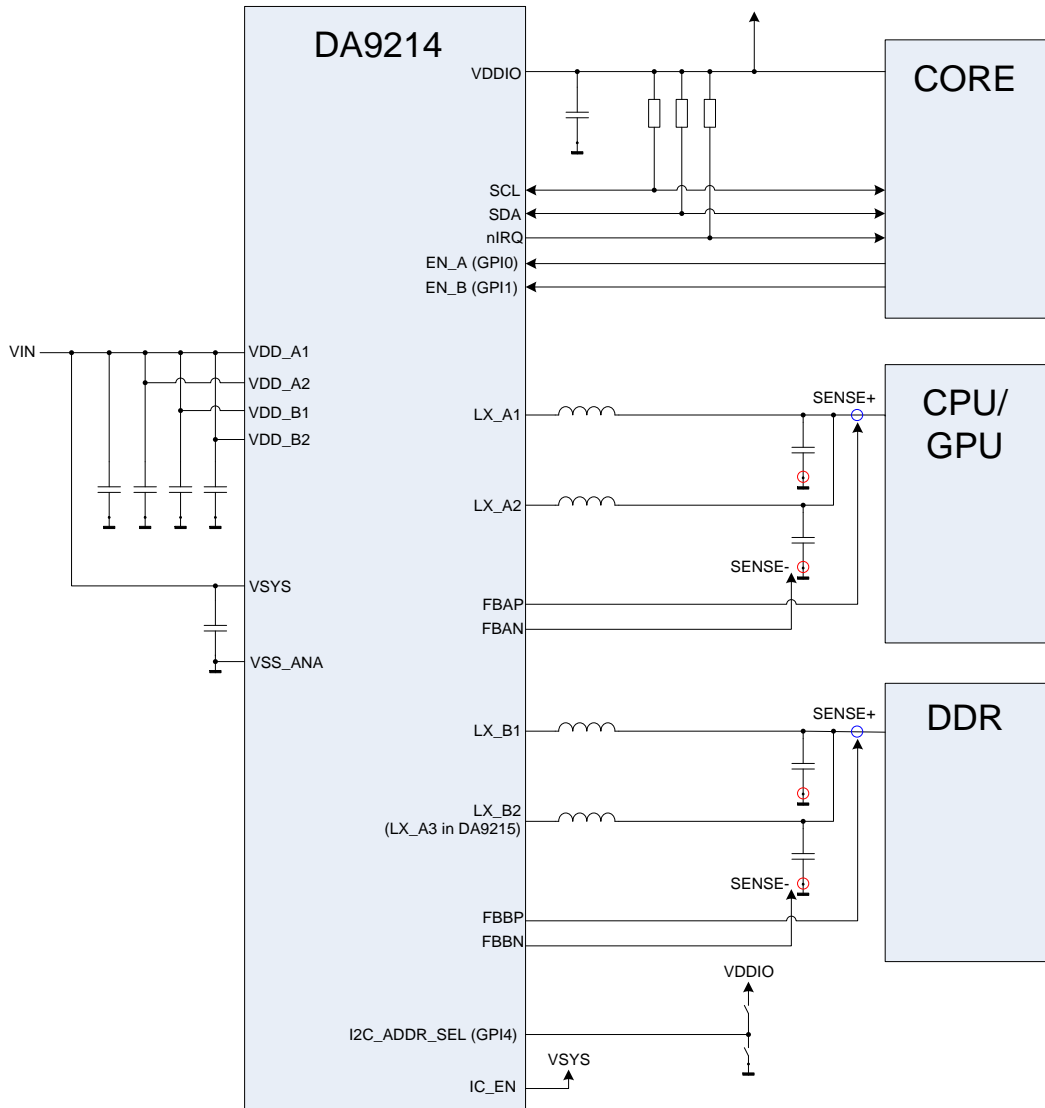

Figure 16: Typical Application of DA9214

Figure 16 shows a typical use case of DA9214 for the simultaneous supply of a CPU and a GPU rail. The IC is always enabled because IC_EN is shorted to the battery voltage. The CORE application processor enables and disables the CPU/GPU and the DDR individually via dedicated ports on DA9214.

7.1 DC_DC Buck Converter

DA9213 is a four phase 20 A high efficiency synchronous step down DVC regulator, operating at a high frequency of typically 3 MHz. It supplies an output voltage of typically 1.0 V for a CPU rail, configurable in the range 0.3 to 1.57 V, with high accuracy in steps of 10 mV.

DA9214 contains two buck converters, Buck A and Buck B, each capable of delivering 10 A.

Multi-Phase 5A/Phase DC-DC Buck Converter

DA9215 contains also two buck converters, Buck A capable of 15 A and Buck B capable of 5 A.

To improve the accuracy of the delivered voltage, each buck converter is able to support a differential sensing of the configured voltage directly at the point of load via dedicated positive and negative sense pins.

Both Buck A and Buck B have two voltage registers each. One defines the normal output voltage, while the other offers an alternative retention voltage. In this way different application power modes can easily be supported. The voltage selection can be operated either via GPI or via control interface to guarantee the maximum flexibility according to the specific host processor status in the application.

When a buck is enabled, its output voltage is monitored and a power good signal indicates that the buck output voltage has reached a level higher than the $V_{TH(PG)}$ threshold. The power good is lost when the voltage drops below $V_{TH(PG)} - V_{HYS(PG)}$, which is the level at which the signal is de-asserted. The power good signaling should not be used in conjunction with fast start up rates, configured in BUCKx_UP_CTRL register fields and can be individually masked during DVC transitions using the [PGA_DVC_MASK](#) and [PGB_DVC_MASK](#) bits. For each of the buck converters the status of the power good indicator can be read back via I²C from the [PWRGOOD_A](#) and [PWRGOOD_B](#) status bits. It can be also individually assigned to either GPIO2 or GPIO3 using [BUCKA_PG_SEL](#) and [BUCKB_PG_SEL](#). For correct functionality, the GPIO ports need to be configured as output. An I²C write in GPIOx_MODE can overwrite the internal configuration so that a new update will be automatically done only when the internal power good indicator changes status.

The buck converters are capable of supporting DVC transitions that occur:

- When the active and selected A-voltage or B-voltage is updated to a new target value.
- When the voltage selection is changed from the A-voltage to the B-voltage (or B-voltage to the A voltage) using [VBUCKA_SEL](#) and [VBUCKB_SEL](#).

The DVC controller operates in Pulse Width Modulation (PWM) mode with synchronous rectification. When the host processor changes the output voltage, the voltage transition of each buck converter can be individually signaled with a READY signal routed to either GPIO2 or GPIO3. The port has to be configured as GPO and selected for the functionality via [READYA_CONF](#) or [READYB_CONF](#). In contrast to the power good signal, the READY only informs the host processor about the completion of the digital DVC ramp without confirming that the target voltage has actually been reached.

The slew rate of the DVC transition is individually programmed for each buck converter at 10 mV per (4, 2, 1, or 0.5 μ s) via control bit [SLEW_RATE_A](#) and [SLEW_RATE_B](#).

The typical supply current is in the order of 17 mA per phase (quiescent current and charge/discharge current) and drops to <1 μ A when the buck is turned off.

When the buck is disabled, a pull down resistor (typically 150 Ω) for each phase is activated depending of the value stored in register bits [BUCKA_PD_DIS](#) and [BUCKB_PD_DIS](#). Phases disabled using [PHASE_SEL_A](#) and [PHASE_SEL_B](#) will not have any pull down. The pull-down resistor is always disabled at all phases when DA9213, DA9214, and DA9215 are OFF.

Multi-Phase 5A/Phase DC-DC Buck Converter

7.1.1 Switching Frequency

The switching frequency is chosen to be high enough to allow the use of a small 0.22 μH inductor (see a complete list of coils in the Application Information, Section 0). The buck switching frequency can be tuned using register bit [OSC_TUNE](#). The internal 6 MHz oscillator frequency is tuned in steps of 180 kHz. This impacts the buck converter frequency in steps of 90 kHz and helps to mitigate possible disturbances to other HF systems in the application.

7.1.2 Operation Modes and Phase Selection

The buck converters can operate in synchronous PWM mode and PFM mode. The operating mode is selected using register bits [BUCKA_MODE](#) and [BUCKB_MODE](#).

An automatic phase shedding can be enabled for each buck converter in PWM mode via [PH_SH_EN_A](#), [PH_SH_EN_B](#), thereby automatically reducing or increasing the number of active phases depending on the output load current. For DA9214 the phase shedding will automatically change between 1-phase and 2-phase operation at a typical current of 2.0 A. For DA9213 the phase shedding will automatically change between 1-phase and 4-phase operation at a typical current of 2.5 A. The [PHASE_SEL_A](#) and [PHASE_SEL_B](#) register fields limit the maximum number of active phases under any conditions.

If the automatic operation mode is selected on [BUCKA_MODE](#) or [BUCKB_MODE](#), the buck converters will automatically change between synchronous PWM mode and PFM depending on the load current. This improves the efficiency of the converters across the whole range of output load currents.

7.1.3 Output Voltage Selection

The switching converter can be configured using either a 2-WIRE or a 4-WIRE interface. For security reasons, the re-programming of registers that can cause damage when wrongly programmed (for example, the voltage settings) can be disabled by asserting the control [V_LOCK](#). When [V_LOCK](#) is asserted, reprogramming the registers 0xD0 to 0x14F from control interfaces is disabled.

For each buck converter two output voltages can be pre-configured inside registers [VBUCKA_A](#) and [VBUCKB_A](#), and registers [VBUCKA_B](#) and [VBUCKB_B](#). The output voltage can be selected by either toggling register bits [VBUCKA_SEL](#) and [VBUCKB_SEL](#) or by re-programming the selected voltage control register. Both changes will result into ramped voltage transitions, during which the [READY](#) signal is asserted. After being enabled, the buck converter will by default use the register settings in [VBUCKA_A](#) and [VBUCKB_A](#) unless the output voltage selection is configured via the GPI port.

If "00" has been selected in [BUCKA_MODE](#) or [BUCKB_MODE](#), A-/B- voltage selection registers [VBUCKx_x](#) control the operation of the PWM and PFM modes.

Regardless of the values programmed in the [VBUCKx_A](#) and [VBUCKx_B](#) registers, the registers [VBUCKA_MAX](#), [VBUCKB_MAX](#) will individually limit the output voltage that can be set for each of the buck converters.

The buck converter provides an optional hardware enable/disable via selectable GPI, and configured via control register bits [BUCKA_GPI](#) and [BUCKB_GPI](#). A change of the output voltage from the state of a GPI is enabled via control register bits [VBUCKA_GPI](#) and [VBUCKB_GPI](#). After detecting a rising or falling edge at the related GPIs, DA9213, DA9214, and DA9215 will configure the buck converters according to their status.

In addition to selecting between the A/B voltages, a track mode can be activated for Buck A to set the output voltage. In the DA9213, the track mode is applied to the 4-phase buck converter. This feature can be enabled on GPIO via [GPIO_PIN](#). The output voltage will be configured to follow the value applied at a selected GPI pin. The voltage applied at GPIO must be in the same range as the nominal output voltage selectable for the buck rail (see [VBUCKA_A](#) and [VBUCKA_B](#) registers). In Track Mode, only single ended remote sensing is possible.

Multi-Phase 5A/Phase DC-DC Buck Converter

In Track Mode, the content of the `VBUCKA_SEL` bit is ignored, as well as `VBUCKA_A` and `VBUCKA_B` bits. They will become active again once the voltage track mode is disabled. The GPIO does not generate any event in this case.

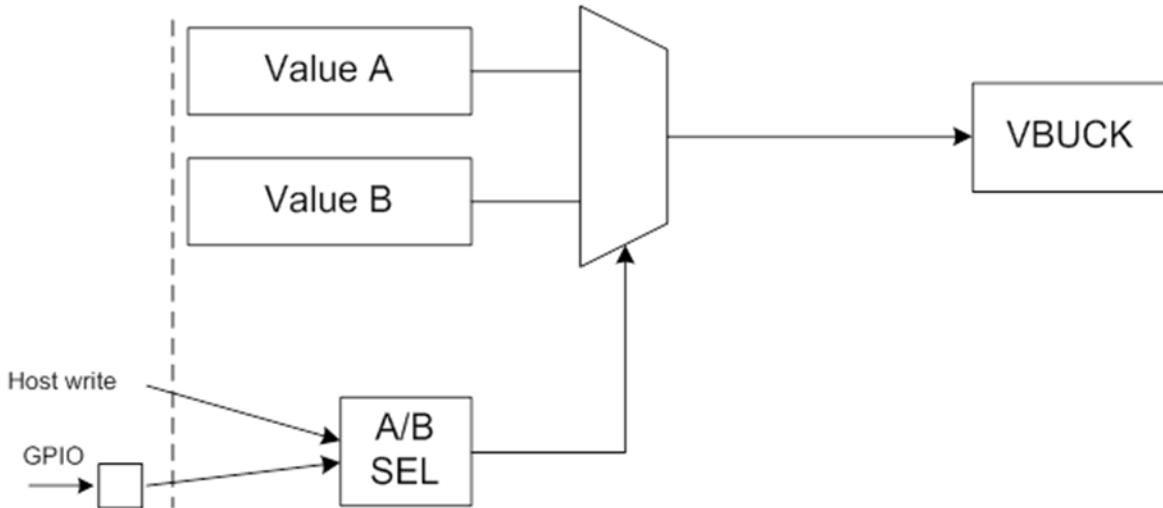

Figure 17: Concept of Control of the Buck's Output Voltage

7.1.4 Soft Start-Up

To limit in-rush current from `VSYS`, the buck converters can perform a soft start after being enabled. The start-up behavior is a compromise between acceptable inrush current from the battery and turn on time. In DA9213, DA9214, and DA9215, different ramp times can be individually configured for each buck converter on register `BUCKA_UP_CTRL` and `BUCKB_UP_CTRL`. Rates higher than 20 mV/ μ s may produce overshoot during the start-up phase, so they should be considered carefully.

A ramped power down can be selected on register bits `BUCKA_DOWN_CTRL` and `BUCKB_DOWN_CTRL`. When no ramp is selected, the output node will be discharged only by the pull down resistor, if enabled via `BUCKA_PD_DIS` and `BUCKB_PD_DIS`.

7.1.5 Current Limit

The integrated current limit is meant to protect DA9213, DA9214, and DA9215's power stages and the external coil from excessive current. The bucks' current limit should be configured to be at least 40 % higher than the required maximum continuous output current.

When reaching the current limit, each buck converter generates an event and an interrupt to the host processor unless the interrupt has been masked using the `OCx_MASK` controls. These `OCA_MASK` and `OCB_MASK` control bits can be used to mask the generation of over current events during DVC transitions. An extra masking time as defined in `OCx_MASK` will be automatically added to the DVC interval after the DVC has finished in order to ensure that the possible high current levels needed for DVC do not influence the event generation.

Multi-Phase 5A/Phase DC-DC Buck Converter

7.1.6 Variable V_{OUT} above 1.57 V

The whole product family is also available with an adjustable output voltage up to 4.3V. A resistive divider from V_{OUT} to FBAN (or FBAN) can be used to set the output voltage higher than 1.57 V, see Figure 18.

The value of the output voltage V_{OUT} is set by the selection of the resistive divider shown in equation 1. The total resistance of the divider resistors (R1+R2) should be less than 40 kΩ.

$$V_{OUT} = \left(1 + \frac{R1}{R2}\right) \cdot V_{REF}$$

Equation 1

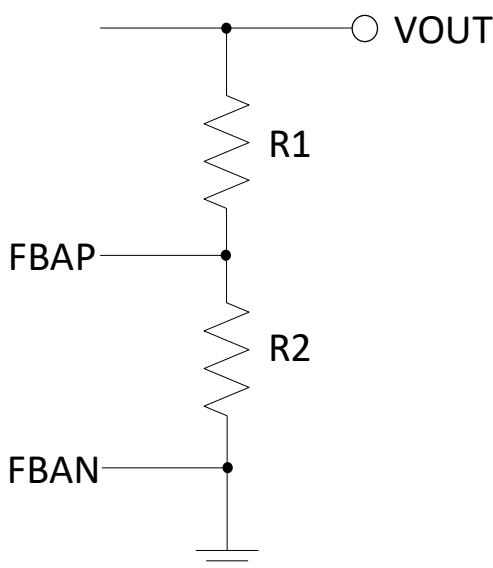

Figure 18: Resistive Divider from V_{OUT} to FBAN

For example, to program the output voltage V_{OUT} to 1.8 V, with V_{REF} set to 1.2 V, suggest 10 kΩ on R1 and 20 kΩ on R2.

Note 1 The resistors need to be properly selected since the output voltage accuracy will be directly affected by any errors on the resistors. The voltage across FBAP and FBAN (V_{REF}) is guaranteed, but not the output voltage accuracy.

CAUTION
<p>The followings are important notes that need to be considered before using resistive divider on DA9213, DA9214, and DA9215:</p> <ol style="list-style-type: none"> 1. Please contact your region's Dialog representative when adopting the resistive divider technique. Dialog need to prepare a special OTP because incorrect OTP settings may result in a different output voltage than expected. 2. The voltage difference between input voltage and output voltage needs to be: above 1.2 V, V_{IN}-V_{OUT} > 1.2 V. 3. The total resistance (R1+R2) is less than 40 kΩ. 4. It is recommended that the device is operated in PWM mode only.

Multi-Phase 5A/Phase DC-DC Buck Converter

7.2 Ports Description

This section describes the functionality of each input / output port.

7.2.1 VDDIO

VDDIO is an independent IO supply rail input to DA9213, DA9214, and DA9215 that can be assigned to the power manager interface and to the GPIOs (see control [PM_IF_V](#) and [GPI_V](#)). The rail assignment determines the IO voltage levels and logical thresholds (see also the Digital I/O Characteristics in [Table 7](#)).

An integrated under-voltage lockout circuit for the VDDIO prevents internal errors by disabling the I²C communication when the voltage drops below V_{ULO_IO} . In that case the buck converters are also disabled and cannot be re-enabled (even via input port) until the VDDIO under-voltage condition has been resolved. At the exit of the VDDIO under-voltage condition an event [E_UVLO_IO](#) is generated and the nIRQ line is driven active if the event is not masked.

The VDDIO under-voltage circuit monitors voltages relative to a nominal voltage of 1.8V. If a different rail voltage is being used, the under-voltage circuit can be disabled via [UVLO_IO_DIS](#).

Note that the maximum speed at 4-WIRE interface is only available if the selected supply rail is greater than 1.6 V.

7.2.2 IC_EN

IC_EN is a general enable signal for DA9213, DA9214, and DA9215, turning on and off the internal circuitry (for example, the reference, the digital core, etc.). Correct control of this port has a direct impact on the quiescent current of the whole application. A low level of IC_EN allows the device to reach the minimum quiescent current. The voltage at this pin is continuously sensed by a dedicated analog circuit.

The host processor will be allowed to start the communication with DA9213, DA9214, and DA9215 through the Control Interface and, for example to turn on the buck converters, a delay time of t_{EN} after assertion of the IC_EN pin. If the bucks are enabled via OTP (see [BUCKA_EN](#) and [BUCKB_EN](#) controls), they will start up automatically after assertion of IC_EN.

The IC_EN activation threshold is defined with a built-in hysteresis to avoid glitching transitions that take place with unstable rising or falling edges.

7.2.3 nIRQ

The nIRQ port indicates that an interrupt causing event has occurred and that the event/status information is available in the related registers. The nIRQ is an output signal that can either be push pull or open drain (selected via [IRQ_TYPE](#)). If an active high IRQ signal is required, it can be achieved by asserting control [IRQ_LEVEL](#) (recommended for push-pull mode).

Examples of this type of information can be critical temperature and voltage, fault conditions, status changes at GPI ports, and so forth. The event registers hold information about the events that have occurred. Events are triggered by a status change at the monitored signals. When an event bit is set, the nIRQ signal is asserted unless this interrupt is masked by a bit in the IRQ mask register. The nIRQ will not be released until all event registers with asserted bits have been read and cleared. New events that occur during reading an event register are held until the event register has been cleared, ensuring that the host processor does not miss them.

Multi-Phase 5A/Phase DC-DC Buck Converter

7.2.4 GPIO Extender

DA9213, DA9214, and DA9215 include a GPIO extender that offers up to five 5 V-tolerant general purpose input/output ports. Each port is controlled via registers from the host processor.

The GPIO3 and GPI4 ports are pin-shared with the 4-WIRE Control Interface. For instance, if `GPIO3_PIN = 01`, `GPI4_PIN = 01` (Interface selected), the GPIO3 and GPI4 ports will be exclusively dedicated to output and chip select signaling for 4-WIRE purposes. If the alternative function is selected, all GPIOs configuration as per registers 0x58 to 0x5A and 0x145 will be ignored.

GPIs are supplied from the internal rail VDDCORE or VDDIO (selected via `GPI_V`) and can be configured to be active high or active low (selected via `GPIOx_TYPE`). The input signals can be debounced or directly change the state of the assigned status register GPIx to high or low, according to the setting of `GPIOx_MODE`. The debouncing time is configurable via control `DEBOUNCE` (10 ms default).

Whenever the status has changed to its configured active state (edge sensitive), the assigned event register is set and the nIRQ signal is asserted (unless this nIRQ is masked, see also [Figure 19](#)).

Whenever DA9213, DA9214, and DA9215 is enabled and enters ON mode (also when enabled changing the setting of `GPIOx_PIN`) the GPI status bits are initiated towards their configured passive state. This ensures that already active signals are detected, and that they create an event immediately after the GPI comparators are enabled.

The buck enable signal (`BUCKx_EN`) can be controlled directly via a GPI, if so configured in the `BUCKA_GPI` and `BUCKB_GPI` registers. If it is required that GPI ports do not generate an event when configured for the HW control of the switching regulator, the relative mask bit should be set.

GPIs can alternatively be selected to toggle the `VBUCKA_SEL` and `VBUCKB_SEL` from rising and falling edges at these inputs. Apart from changing the regulator output voltage this also provides hardware control of the regulator mode (normal/low power mode) from the settings of `BUCKA_SL_A`, `BUCKA_SL_B`, `BUCKB_SL_A`, and `BUCKB_SL_B` (enabled if `BUCKA_MODE` or `BUCKB_MODE = 00`).

All GPI ports have the additional option of activating a 100 kΩ pull-down resistor via `GPIOx_PUPD`, which ensures a well-defined level in case the input is not actively driven.

If enabled via `ADDR_SEL_CONF`, the I²C address selection can be assigned to a specific GPI. An active voltage level at the selected GPI configures the slave address of DA9213, DA9214, and DA9215 to `IF_BASE_ADDR1` while a passive voltage level configures the slave address to `IF_BASE_ADDR2`. If no GPI is selected then the `IF_BASE_ADDR1` is automatically used.

If defined as an output, GPIOs can be configured to be open-drain or push-pull. If configured as push pull, the supply rail is VDDIO. By disabling the internal 120 kΩ pull-up resistor in open-drain mode, the GPO can also be supplied from an external rail. The output state will be assigned as configured by the GPIO register bit `GPIOx_MODE`.

A specific power good port for each of the buck converters can be configured via `BUCKA_PG_SEL` and `BUCKB_PG_SEL`. The respective port must be configured as GPO for correct operation. If assigned to the same GPO, it is necessary that the power good indicators for Buck A and Buck B are both active (supply voltages in range) to assert the overall power good. The signal will be released as soon as one of the single power good signals is not active (that is, at least one supply is out of range).

The power good signaling should not be used in conjunction with fast start up rates, configured in `BUCKx_UP_CTRL` register fields.

Once enabled via `RELOAD_FUNC_EN` the GPIO0 can be used as input port to operate a partial OTP download. When the input level is changed to active, the registers 0x5D, 0x5E, 0xD1 to 0xDA are updated to their OTP default. This allows a complete buck re-configuration that resets all the changes done to those registers previously (soft reset). If the buck should be kept on during the soft reset, the OTP values for the enable bits should be asserted because they are also part of the re-load.

Multi-Phase 5A/Phase DC-DC Buck Converter

Whenever the GPIO unit is off (POR or OFF Mode) all ports are configured as open drain active high (pass device switched off, high impedance state). When leaving POR the pull-up or pull-down resistors will be configured from register GPIOx_PUPD.

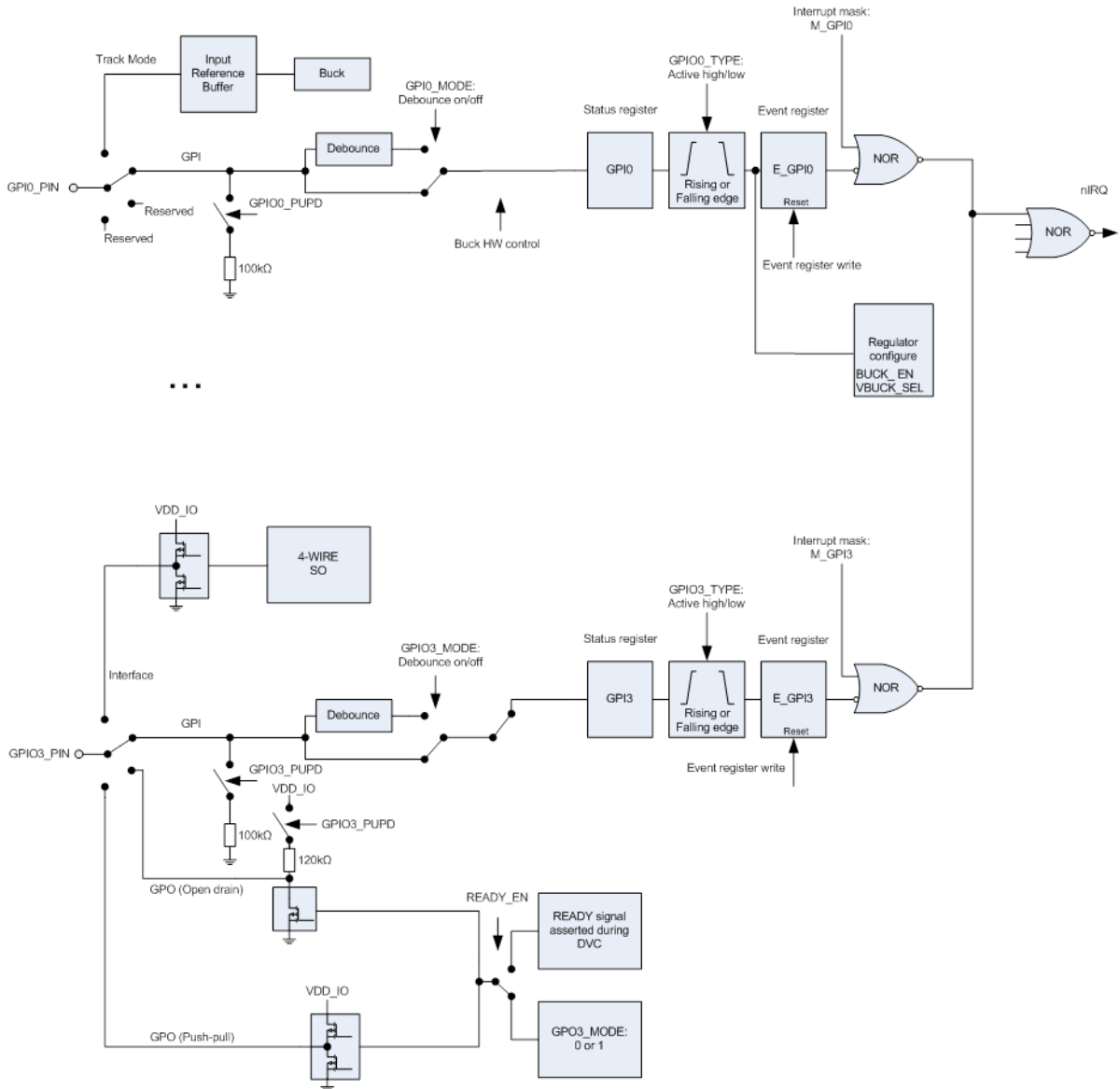

Figure 19: GPIO Principle of Operation (Example Paths)

Multi-Phase 5A/Phase DC-DC Buck Converter

7.3 Operating Modes

7.3.1 ON Mode

DA9213, DA9214, and DA9215 are in ON Mode when the IC_EN port is higher than EN_ON and the supply voltage is higher than $V_{TH(UVLO)(VDD)}$. Once enabled, the host processor can start the communication with DA9213, DA9214, and DA9215 via Control Interface after the t_{EN} delay needed for internal circuit start up.

If **BUCKA_EN** or **BUCKB_EN** is asserted when DA9213, DA9214, and DA9215 is in ON Mode the power up of the related buck converter is initiated. If the bucks are controlled via GPI, the level of the controlling ports is checked when entering ON mode, so that an active level will immediately have effect on the buck. If **BUCKA_EN** or **BUCKB_EN** are not asserted and all controlling GPI ports are inactive, the buck converter will stay off with the output pull down resistor enabled/disabled according to the setting of **BUCKA_PD_DIS** and **BUCKB_PD_DIS**.

7.3.2 OFF Mode

DA9213, DA9214, and DA9215 are in OFF Mode when the IC_EN port is lower than EN_OFF. In OFF Mode, the bucks are always disabled and the output pull down resistors are disabled independently of **BUCKA_PD_DIS** and **BUCKB_PD_DIS**. All I/O ports of DA9213, DA9214, and DA9215 are configured as high impedance.

7.4 Control Interfaces

All the features of DA9213, DA9214, and DA9215 can be controlled by SW through a serial control interfaces. The communication is selectable to be either a 2-WIRE (I²C compliant) or a 4-WIRE connection (SPI compliant) via control **IF_TYPE**, which will be selected during the initial OTP read. If 4-WIRE is selected, the GPIO3 and GPI4 are automatically configured as interface pins. Data is shifted into or out of DA9213, DA9214, and DA9215 under the control of the host processor, which also provides the serial clock. In a normal application case, the interface is only configured once from OTP values, which are loaded during the initial start-up of DA9213, DA9214, and DA9215.

DA9213, DA9214, and DA9215 reacts only on read/write commands where the transmitted register address (using the actual page bits as a MSB address range extensions) is within 0x50 to 0x67, 0xD0 to DF, 0x140 to 0x14F and (read only) 0x200 to 0x27F. Host access to registers outside these ranges will be ignored. This means there will be no acknowledge after receiving the register address in 2-WIRE Mode, and SO stays HI-Z in 4-WIRE Mode. During debug and production modes write access is available to page 4 (0x200 to 0x27F). DA9213, DA9214, and DA9215 will react only on write commands where the transmitted register address is 0x00, 0x80, 0x100 to 0x106. The host processor must read the content of those registers before writing, thereby changing only the bit fields that are not marked as reserved (the content of the read back comes from the compatible PMIC, for example DA9063).

If the **STAND_ALONE** bit is asserted (OTP bit), DA9213, DA9214, and DA9215 will also react to read commands.

7.4.1 4-WIRE Communication

In 4-WIRE Mode the interface uses a chip-select line (nCS/nSS), a clock line (SK), data input (SI) and data output line (SO).

The DA9213, DA9214, and DA9215 register map is split into four pages that each contain up to 128 registers. The register at address zero on each page is used as a page control register. The default active page after turn on includes registers 0x50 to 0x6F. Writing to the page control register changes the active page for all subsequent read/write operations unless an automatic return to page 0 was selected by asserting bit **REVERT**. Unless the **REVERT** bit was asserted after modifying the active page, it is recommended to read back the page control register to ensure that future data exchange is accessing the intended registers.

Multi-Phase 5A/Phase DC-DC Buck Converter

All registers outside the DA9213, DA9214, and DA9215 range are write only, that is, the DA9213, DA9214, and DA9215 will not answer to a read command and the data bus is tristate (they are implicitly directed to DA9063). In particular the information contained in registers 0x105 and 0x106 is used by DA9213, DA9214, and DA9215 to configure the control interface. They must be the same as the main PMIC (DA9063), so that a write to those registers configures both the main PMIC and DA9213, DA9214, and DA9215 at the same time. The default OTP settings also need to be identical for a correct operation of the system.

The 4-WIRE interface features a half-duplex operation, that is, data can be transmitted and received within a single 16-bit frame at enhanced clock speed (up to 14 MHz). It operates at the clock frequencies provided by the host.

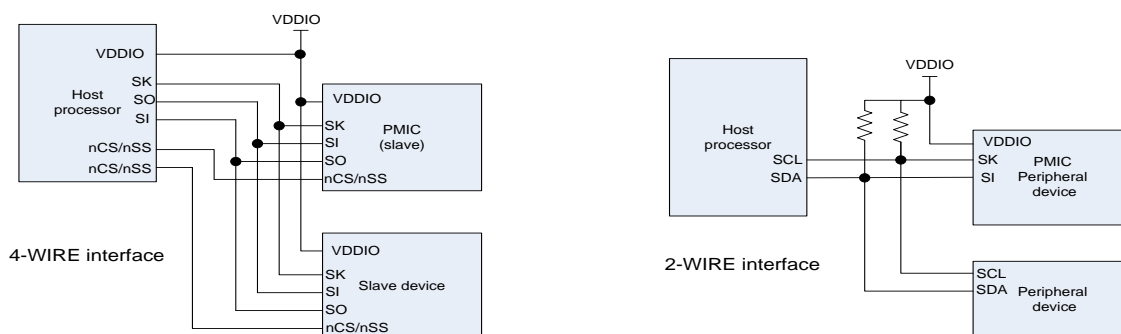

Figure 20: Schematic of 4-WIRE and 2-WIRE Power Manager Bus

A transmission begins when initiated by the host. Reading and writing is accomplished by the use of an 8-bit command, which is sent by the host prior to the exchanged 8-bit data. The byte from the host begins shifting in on the SI pin under the control of the serial clock SK provided from the host. The first seven bits specify the register address (0x01 to 0x07) that will be written or read by the host. The register address is automatically decoded after receiving the seventh address bit. The command word ends with an R/W bit, which together with the control bit R/W_POL specifies the direction of the following data exchange. During register writing the host continues sending out data during the following eight SK clocks. For reading, the host stops transmitting and the 8-bit register is clocked out of DA9213, DA9214, and DA9215 during the consecutive eight SK clocks of the frame. Address and data are transmitted with MSB first. The polarity (active state) of nCS is defined by control bit nCS_POL. nCS resets the interface when inactive and it has to be released between successive cycles.

The SO output from DA9213, DA9214, and DA9215 is normally in high-impedance state and active only during the second half of read cycles. A pull-up or pull-down resistor may be needed at the SO line if a floating logic signal can cause unintended current consumption inside other circuits.

Table 10: 4-WIRE Clock Configurations

CPHA Clock Polarity	CPOL Clock Phase	Output Data is Updated at SK Edge	Input Data is Registered at SK Edge
0 (idle low)	0	Falling	Rising
0 (idle low)	1	Rising	Falling
1 (idle high)	0	Rising	Falling
1 (idle high)	1	Falling	Rising

DA9213, DA9214, and DA9215's 4-WIRE interface offers two further configuration bits. Clock polarity (CPOL) and clock phase (CPHA) define when the interface will latch the serial data bits. CPOL determines whether SK idles high (CPOL = 1) or low (CPOL = 0). CPHA determines on which SK edge data is shifted in and out. With CPOL = 0 and CPHA = 0, DA9213, DA9214, and DA9215 latch data on the SK rising edge. If the CPHA is set to 1 the data is latched on the SK falling edge. CPOL

Multi-Phase 5A/Phase DC-DC Buck Converter

and **CPHA** states allow four different combinations of clock polarity and phase. Each setting is incompatible with the other three. The host and DA9213, DA9214, and DA9215 must be set to the same **CPOL** and **CPHA** states to communicate with each other.

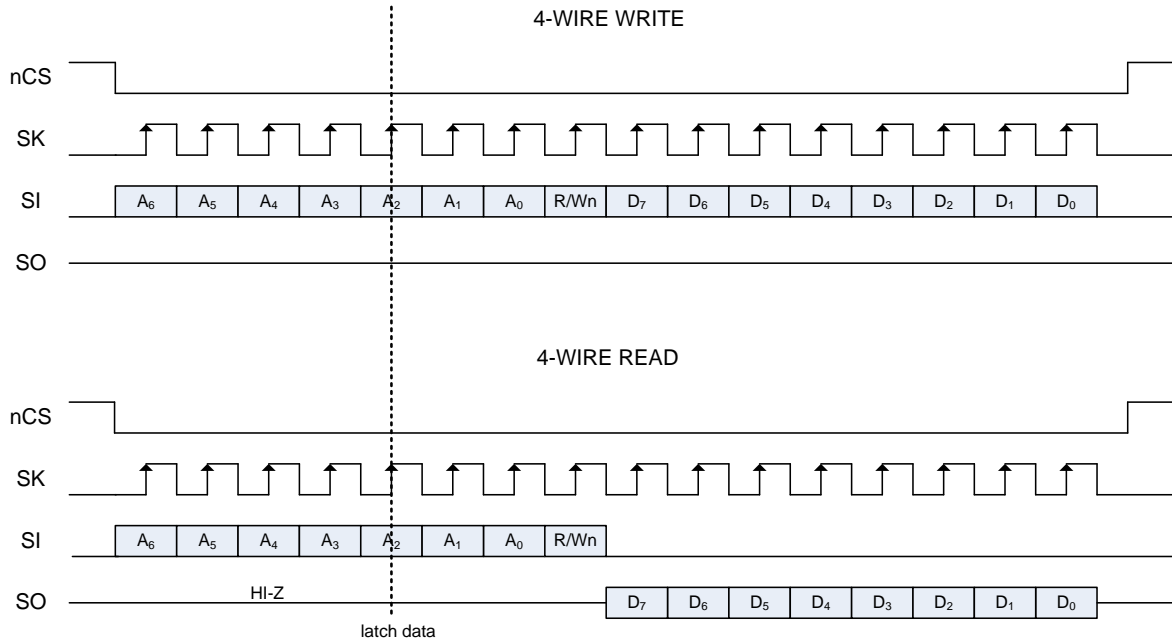

Figure 21: 4-WIRE Host Write and Read Timing (nCS_POL = 0, CPOL = 0, CPHA = 0)

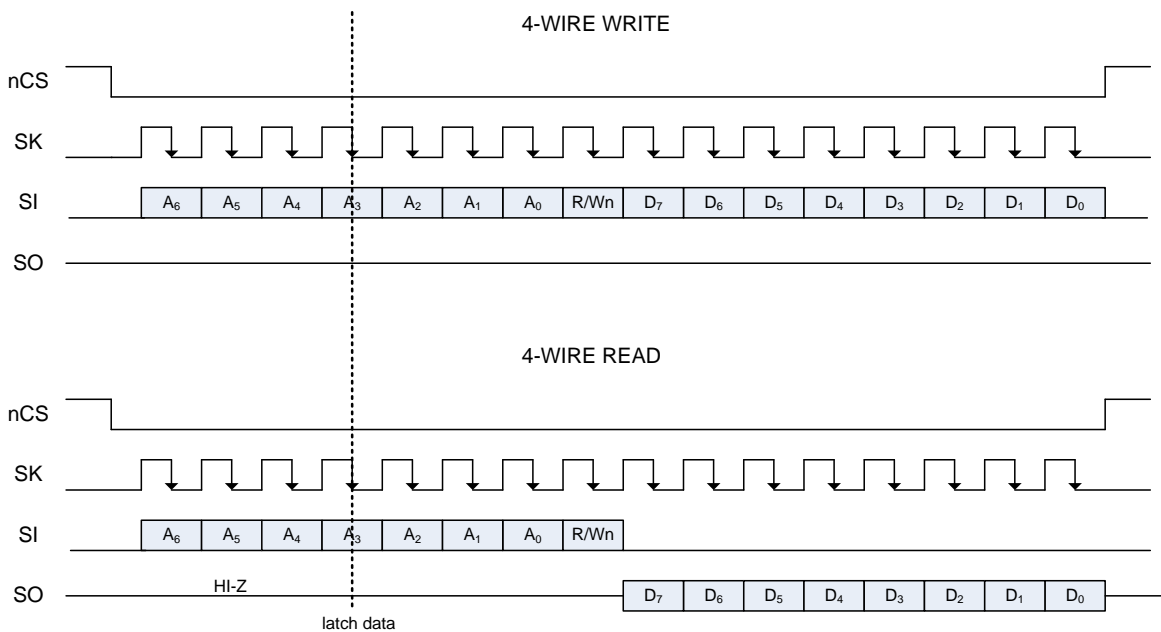

Figure 22: 4-WIRE Host Write and Read Timing (nCS_POL= 0, CPOL = 0, CPHA = 1)

Multi-Phase 5A/Phase DC-DC Buck Converter

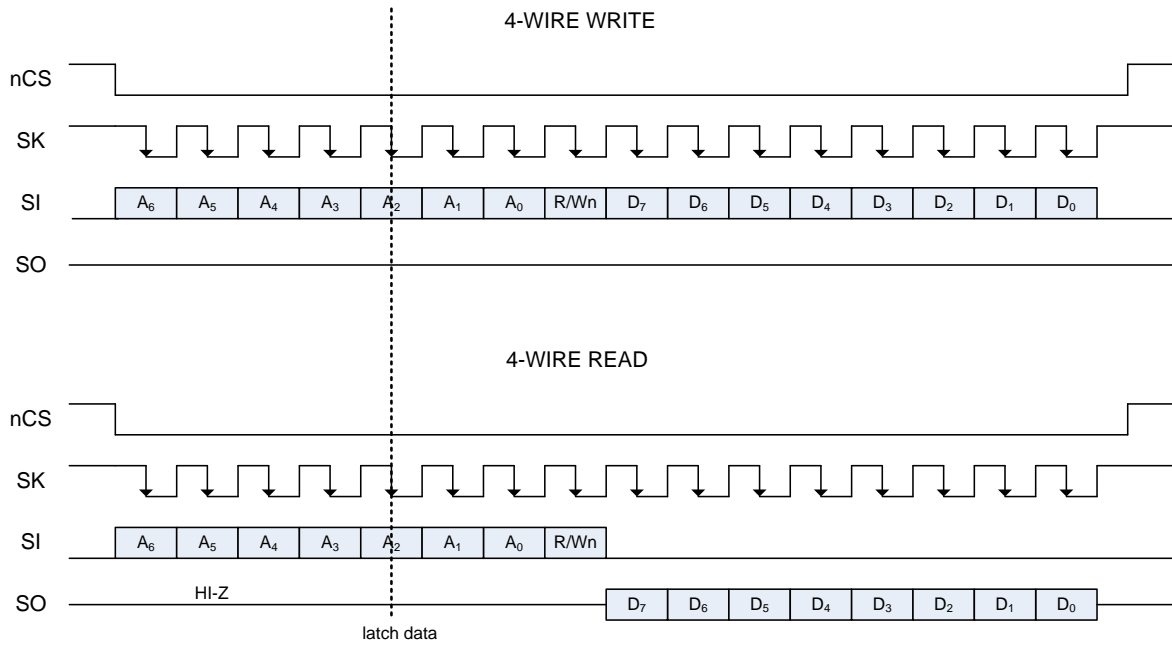

Figure 23: 4-WIRE Host Write and Read Timing (nCS_POL = 0, CPOL = 1, CPHA = 0)

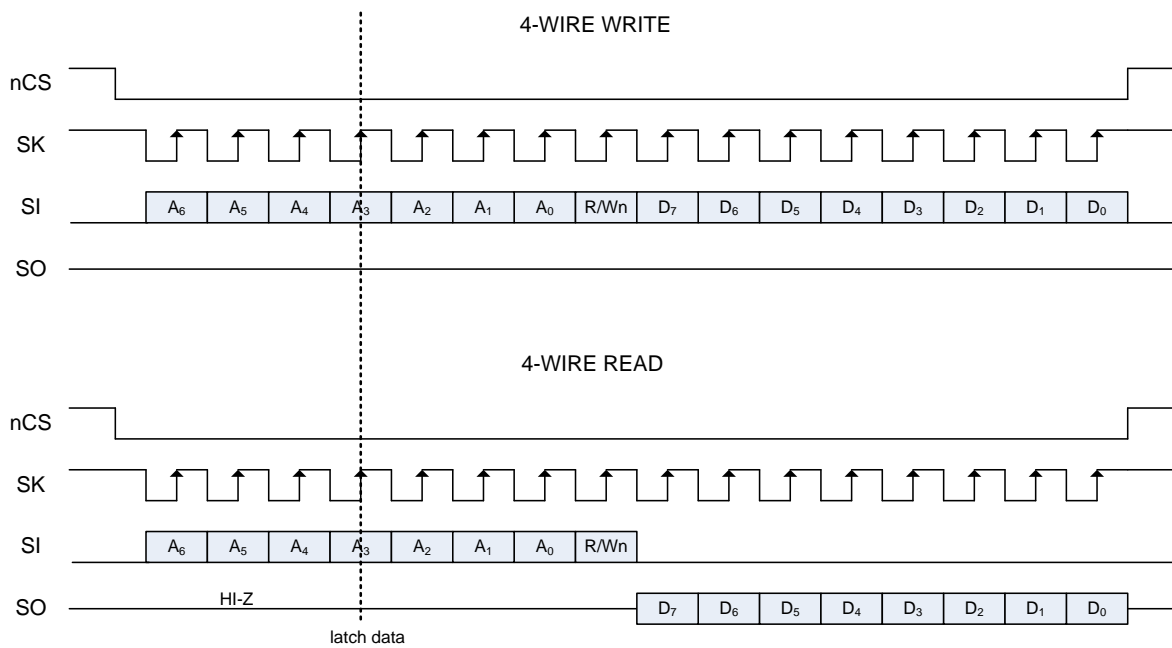

Figure 24: 4-WIRE Host Write and Read Timing (nCS_POL = 0, CPOL = 1, CPHA = 1)

Multi-Phase 5A/Phase DC-DC Buck Converter

Table 11: 4-WIRE Interface Summary

Parameters		
Signal lines	nCS	Chip select
	SI Serial input data	Master out Slave in
	SO Serial output data	Master in Slave out
	SK	Transmission clock
Interface	Push-pull with tristate	
Supply voltage	Selected from VDDIO	1.6 V to 3.3 V
Data rate	Effective read/write data	Up to 7 Mbps
Transmission	Half-duplex	MSB first
	16-bit cycles	7-bit address, 1-bit read/write, 8-bit data
Configuration	CPOL	Clock polarity
	CPHA	Clock phase
	nCS_POL	nCS is active low/high

Note 1 Reading the same register at high clock rates directly after writing it does not guarantee a correct value. It is recommended to keep a delay of one frame until re-accessing a register that has just been written (for example, by writing/reading another register address in-between).

7.4.2 2-WIRE Communication

The **IF_TYPE** bit in the **INTERFACE2** register can be used to configure the DA9213, DA9214, and DA9215 control interface as a 2-WIRE serial data interface. In this case the GPIO3 and GPI4 are free for regular input/output functions. DA9213, DA9214, and DA9215 has a configurable device write address (default: 0xD0) and a configurable device read address (default: 0xD1). See control **IF_BASE_ADDR1** for details of configurable addresses. The **ADDR_SEL_CONF** bit is used to configure the device address as **IF_BASE_ADDR1** or **IF_BASE_ADDR2** depending on the voltage level applied at a configurable GPI port (see Section 7.2.4).

The SK port functions as the 2-WIRE clock and the SI port carries all the power manager bidirectional 2-WIRE data. The 2-WIRE interface is open-drain supporting multiple devices on a single line. The bus lines have to be pulled HIGH by external pull-up resistors (in the 2 kΩ to 20 kΩ range). The attached devices only drive the bus lines LOW by connecting them to ground. As a result two devices cannot conflict if they drive the bus simultaneously. In standard/fast mode the highest frequency of the bus is 400 kHz. The exact frequency can be determined by the application and does not have any relation to the DA9213, DA9214, and DA9215 internal clock signals. DA9213, DA9214, and DA9215 will follow the host clock speed within the described limitations, and does not initiate any clock arbitration or slow down. An automatic interface reset can be triggered using control **2WIRE_TO** if the clock signal stops to toggle for more than 35 ms.

The interface supports operation compatible to Standard, Fast, Fast-Plus and High Speed mode of the I²C-bus specification Rev 4. Operation in high speed mode at 3.4 MHz requires mode changing in order to set spike suppression and slope control characteristics to be compatible with the I²C-bus specification. The high speed mode can be enabled on a transfer by transfer basis by sending the master code (0000 1XXX) at the beginning of the transfer. DA9213, DA9214, and DA9215 do not make use of clock stretching, and deliver read data without additional delay up to 3.4 MHz.

Alternatively, **PM_IF_HSM** configures the interface to use high speed mode continuously. In this case, the master code is not required at the beginning of every transfer. This reduces the communication overhead on the bus but limits the slaves attachable to the bus to compatible devices.

Multi-Phase 5A/Phase DC-DC Buck Converter

The communication on the 2-WIRE bus always takes place between two devices, one acting as the master and the other as the slave. The DA9213, DA9214, and DA9215 will only operate as a SLAVE.

In contrast to the 4-WIRE mode, the 2-WIRE interface has direct access to two pages of the register map (up to 256 addresses). The register at address zero on each page is used as a page control register (with the 2-WIRE bus ignoring the LSB of control `REG_PAGE`). Writing to the page control register changes the active page for all subsequent read/write operations unless an automatic return to page 0 was selected by asserting control `REVERT`. Unless `REVERT` was asserted after modifying the active page, it is recommended to read back the page control register to ensure that future data exchange is accessing the intended registers.

In 2-WIRE operation DA9213, DA9214, and DA9215 offer an alternative way to access register page 2 and page 3. It removes the need for preceding page selection writes by incrementing the device write/read address by one (default 0xD2/0xD3) for any direct access of page 2 and page 3 (page 0 and 1 access requires the basic write/read device address with the MSB of `REG_PAGE` to be 0).

7.4.3 Details of the 2-WIRE Control Bus Protocol

All data is transmitted across the 2-WIRE bus in groups of eight bits. To send a bit the SDA line is driven towards the intended state while the SCL is LOW (a low on SDA indicates a zero bit). Once the SDA has settled, the SCL line is brought HIGH and then LOW. This pulse on SCL clocks the SDA bit into the receiver's shift register.

A two-byte serial protocol is used containing one byte for address and one byte data. Data and address transfer are transmitted MSB first for both read and write operations. All transmissions begin with the START condition from the master while the bus is in IDLE state (the bus is free). It is initiated by a high to low transition on the SDA line while the SCL is in the high state (a STOP condition is indicated by a low to high transition on the SDA line while the SCL is in the high state).



Figure 25: Timing of 2-WIRE START and STOP Condition

The 2-WIRE bus is monitored by DA9213, DA9214, and DA9215 for a valid SLAVE address whenever the interface is enabled. It responds immediately when it receives its own slave address. The acknowledge is done by pulling the SDA line low during the following clock cycle (white blocks marked with A in [Figure 26](#) to [Figure 30](#)).

The protocol for a register write from master to slave consists of a start condition, a slave address with read/write bit and the 8-bit register address followed by eight bits of data terminated by a STOP condition. DA9213, DA9214, and DA9215 respond to all bytes with Acknowledge. This is illustrated in [Figure 26](#).

Multi-Phase 5A/Phase DC-DC Buck Converter

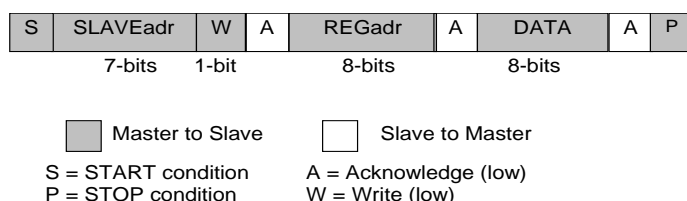

Figure 26: 2-WIRE Byte Write (SDA Line)

When the host reads data from a register it first has to write to DA9213, DA9214, and DA9215 with the target register address and then read from DA9213, DA9214, and DA9215 with a Repeated START or alternatively a second START condition. After receiving the data, the host sends No Acknowledge and terminates the transmission with a STOP condition. This is illustrated in Figure 27.

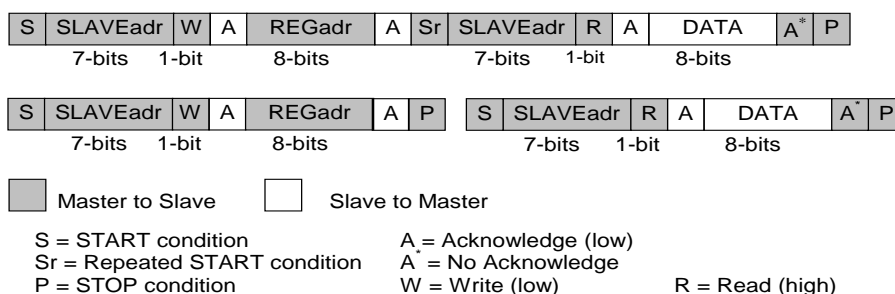

Figure 27: Examples of 2-WIRE Byte Read (SDA Line)

Consecutive (page) read out mode is initiated from the master by sending an Acknowledge instead of Not acknowledge after receipt of the data word. The 2-WIRE control block then increments the address pointer to the next 2-WIRE address and sends the data to the master. This enables an unlimited read of data bytes until the master sends a Not acknowledge directly after the receipt of data, followed by a subsequent STOP condition. If a non-existent 2-WIRE address is read out, the DA9213, DA9214, and DA9215 will return code zero. This is illustrated in Figure 28.

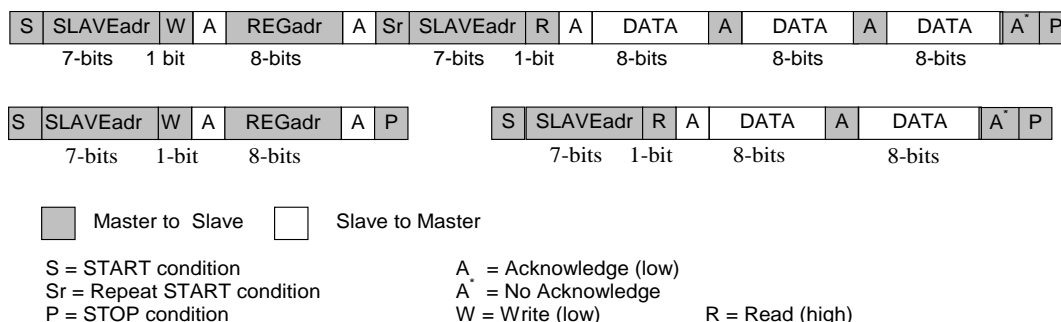

Figure 28: Examples of 2-WIRE Page Read (SDA Line)

Note that the slave address after the Repeated START condition must be the same as the previous slave address.

Consecutive (page) write mode is supported if the Master sends several data bytes following a slave register address. The 2-WIRE control block then increments the address pointer to the next 2-WIRE address, stores the received data and sends an Acknowledge until the master sends the STOP condition. This is illustrated in Figure 29.

Multi-Phase 5A/Phase DC-DC Buck Converter

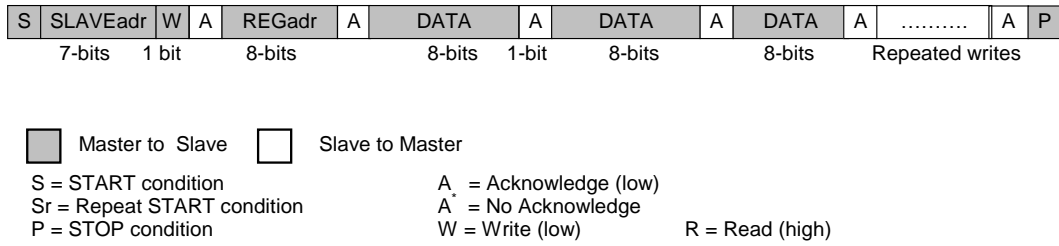

Figure 29: 2-WIRE Page Write (SDA Line)

Via control [WRITE_MODE](#) an alternate write mode can be configured. Register addresses and data are sent in alternation like in [Figure 30](#) to support host repeated write operations that access several non-consecutive registers. Data will be stored at the previously received register address.

An update of [WRITE_MODE](#) cannot be done without interruption within a transmission frame. Thus, if not previously selected or not set as OTP default, the activation of Repeated Write must be done with a regular write on [WRITE_MODE](#) followed by a stop condition. The next frame after a start condition can be written in Repeated Write.

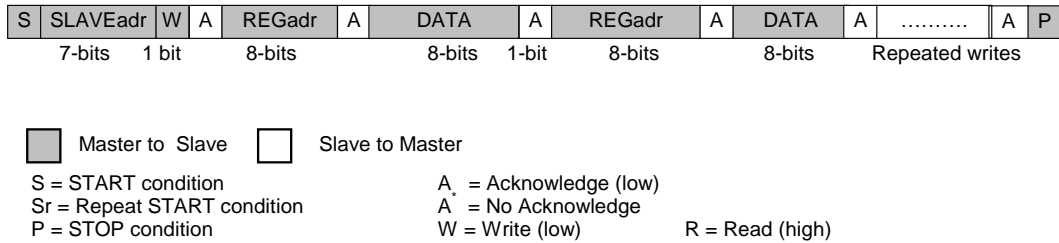

Figure 30: 2-WIRE Repeated Write (SDA Line)

If a new START or STOP condition occurs within a message, the bus will return to IDLE mode.

Multi-Phase 5A/Phase DC-DC Buck Converter

7.5 Internal Temperature Supervision

To protect DA9213, DA9214, and DA9215 from damage due to excessive power dissipation, the internal temperature is continuously monitored. There are three temperature thresholds, as shown in Table 12.

Table 12: Over-Temperature Thresholds

Temperature Threshold	Typical Temperature Setting	Interrupt Event	Status Bit	Masking Bit
TEMP_WARN	125 °C	E_TEMP_WARN	TEMP_WARN	M_TEMP_WARN
TEMP_CRIT	140 °C	E_TEMP_CRIT	TEMP_CRIT	M_TEMP_CRIT
TEMP_POR	150 °C			

When the junction temperature reaches the TEMP_WARN threshold, DA9213, DA9214, and DA9215 will assert the bit TEMP_WARN and will generate the event E_TEMP_WARN. If not masked using bit M_TEMP_WARN, the output port nIRQ will be asserted. The status bit TEMP_WARN will remain asserted as long as the junction temperature remains higher than TEMP_WARN.

When the junction temperature increases further to TEMP_CRIT, DA9213, DA9214, and DA9215 will immediately disable the buck converter, assert the bit TEMP_CRIT, and will generate the event E_TEMP_CRIT. If not masked via bit M_TEMP_CRIT, the output port nIRQ will be asserted. The status bit TEMP_CRIT will remain asserted as long as the junction temperature remains higher than TEMP_CRIT. The buck converter will be kept disabled as long as the junction temperature is above TEMP_CRIT. It will not be automatically re-enabled even after the temperature drops below the valid threshold (even if the controlling GPI is asserted). A direct write into [BUCKA_EN](#) or [BUCKB_EN](#), or a toggling of the controlling GPI, is needed to enable the buck converter.

Whenever the junction temperature exceeds TEMP_POR, a power on reset to the digital core is immediately asserted, which stops all functionalities of DA9213, DA9214, and DA9215. This is needed to prevent possible permanent damage in the case of a rapid temperature increase.

Register Definitions

8.1 Register Map

Table 13 displays the register map, where all bits loaded from OTP are marked in bold.

DA9213, DA9214, and DA9215

Multi-Phase 5A/Phase DC-DC Buck Converter

Table 13: Register Map

Addr	Function	7	6	5	4	3	2	1	0
Register Page 0									
0x00	PAGE_CON	REVERT	WRITE_MODE	Reserved	Reserved	REG_PAGE			
0x50	STATUS_A	Reserved	Reserved	Reserved	GPIO4	GPIO3	GPIO2	GPIO1	GPIO0
0x51	STATUS_B	RAMP_READY_B	RAMP_READY_A	OV_CURR_B	OV_CURR_A	TEMP_CRIT	TEMP_WARN	PWRGOOD_B	PWRGOOD_A
0x52	EVENT_A	Reserved	E_UVLO_IO	Reserved	E_GPIO4	E_GPIO3	E_GPIO2	E_GPIO1	E_GPIO0
0x53	EVENT_B	Reserved	Reserved	E_OV_CURR_B	E_OV_CURR_A	E_TEMP_CRIT	E_TEMP_WARN	E_PWRGOODB	E_PWRGOOD_A
0x54	MASK_A	Reserved	M_UVLO_IO	Reserved	M_GPIO4	M_GPIO3	M_GPIO2	M_GPIO1	M_GPIO0
0x55	MASK_B	Reserved	Reserved	M_OV_CURR_B	M_OV_CURR_A	M_TEMP_CRIT	M_TEMP_WARN	M_PWRGOOD_B	M_PWRGOOD_A
0x56	CONTROL_A	V_LOCK	SLEW_RATE_B		SLEW_RATE_A		DEBOUNCING		
0x57	Reserved	Reserved	Reserved	Reserved	Reserved	Reserved	Reserved	Reserved	Reserved
0x58	GPIO0-1	GPIO0_MODE	GPIO1_TYPE	GPIO1_PIN		GPIO0_MODE	GPIO1_TYPE	GPIO0_PIN	
0x59	GPIO2-3	GPIO3_MODE	GPIO3_TYPE	GPIO3_PIN		GPIO2_MODE	GPIO2_TYPE	GPIO2_PIN	
0x5A	GPIO4	Reserved	Reserved	Reserved		GPIO4_MODE	GPIO4_TYPE	GPIO4_PIN	
0x5B	Reserved	Reserved	Reserved	Reserved		Reserved	Reserved	Reserved	
0x5C	Reserved	Reserved	Reserved	Reserved	Reserved	Reserved	Reserved	Reserved	Reserved
0x5D	BUCKA_CONT	Reserved	YBUCKA_GPI		YBUCKA_SEL	BUCKA_PD_DIS	BUCKA_GPI		BUCKA_EN
0x5E	BUCKB_CONT	Reserved	YBUCKB_GPI		YBUCKB_SEL	BUCKB_PD_DIS	BUCKB_GPI		BUCKB_EN
Register Page 1									
0x80	PAGE_CON	REVERT	WRITE_MODE	Reserved	Reserved	Reserved	REG_PAGE		
0xD0	BUCK_ILIM	BUCKB_ILIM				BUCKA_ILIM			
0xD1	BUCKA_CONF	BUCKA_DOWN_CTRL			BUCKA_UP_CTRL			BUCKA_MODE	
0xD2	BUCKB_CONF	BUCKB_DOWN_CTRL			BUCKB_UP_CTRL			BUCKB_MODE	
0xD3	BUCK_CONF	Reserved	Reserved	Reserved	PH_SH_EN_B	PH_SH_EN_A	PHASE_SEL_B	PHASE_SEL_A	
0xD4	Reserved	Reserved	Reserved	Reserved	Reserved	Reserved	Reserved	Reserved	Reserved
0xD5	YBUCKA_MAX	Reserved					YBUCKA_MAX		
0xD6	YBUCKB_MAX	Reserved					YBUCKB_MAX		
0xD7	YBUCKA_A	BUCKA_SL_A						YBUCKA_A	
0xD8	YBUCKA_B	BUCKA_SL_B						YBUCKA_B	
0xD9	YBUCKB_A	BUCKB_SL_A						YBUCKB_A	
0xDA	YBUCKB_B	BUCKB_SL_B						YBUCKB_B	
Register Page 2									
0x100	PAGE_CON	REVERT	WRITE_MODE	Reserved	Reserved	Reserved	REG_PAGE		
0x101	Reserved	Reserved	Reserved	Reserved	Reserved	Reserved	Reserved	Reserved	Reserved
0x102	Reserved	Reserved	Reserved	Reserved	Reserved	Reserved	Reserved	Reserved	Reserved
0x103	Reserved	Reserved	Reserved	Reserved	Reserved	Reserved	Reserved	Reserved	Reserved
0x104	Reserved	Reserved	Reserved	Reserved	Reserved	Reserved	Reserved	Reserved	Reserved
0x105	INTERFACE	IF_BASE_ADDR1				RIV_POL	CPHA	CPOL	nCS_POL
0x106	INTERFACE2	IF_TYPE	PM_IF_HSM	PM_IF_FMP	PM_IF_V	Reserved	Reserved	Reserved	Reserved
0x140	Reserved	Reserved	Reserved	Reserved	Reserved	Reserved	Reserved	Reserved	Reserved
0x141	Reserved	Reserved							
0x142	Reserved	Reserved							
0x143	CONFIG_A	Reserved	Reserved	Reserved	2WIRE_TO	GPIO_V	Reserved	IRQ_TYPE	IRQ_LEVEL
0x144	CONFIG_B	UVLO_IO_DIS	PGB_DVC_MASK	PGA_DVC_MASK	OCB_MASK		OCA_MASK		RELOAD_FUNC_EN
0x145	CONFIG_C	Reserved	Reserved	Reserved	GPIO_PUPD	GPIO3_PUPD	GPIO2_PUPD	GPIO1_PUPD	GPIO0_PUPD
0x146	CONFIG_D	BUCKB_PG_SEL			BUCKA_PG_SEL		READYB_CONF		READYA_CONF
0x147	CONFIG_E	STAND_ALONE	Reserved	Reserved	Reserved	Reserved	OSC_TUNE		
0x148	CONFIG_F	IF_BASE_ADDR2				Reserved	Reserved	ADDR_SEL_CONF	

Multi-Phase 5A/Phase DC-DC Buck Converter

8.1.1 Register Page Control

Register	Bit	Type	Label	Description
0x00 PAGE_CON	7	R/W	REVERT	Resets REG_PAGE to 000 after read/write access has finished
	6	R/W	WRITE_MODE	2-WIRE multiple write mode (Note 1) 0: Page Write Mode 1: Repeated Write Mode
	5:3	R/W	(reserved)	
	2:0	R/W	REG_PAGE	I ² C 00x: Selects Register 0x00 to 0xFF 01x: Selects Register 0x100 to 0x17F SPI 000: Selects Register 0x00 to 0x7F 001: Selects Register 0x80 to 0xFF 010: Selects Register 0x100 to 0x17F >010: Reserved for production and test

Note 1 Not used for 4-WIRE-IF

8.1.2 Register Page 0

8.1.2.1 System Control and Event

The STATUS registers report the current value of the various signals at the time that it is read out.

Register	Bit	Type	Label	Description
0x50 STATUS_A	7:5	R	(reserved)	
	4	R	GPI4	GPI4 level
	3	R	GPI3	GPI3 level
	2	R	GPI2	GPI2 level
	1	R	GPI1	GPI1 level
	0	R	GPI0	GPI0 level

Register	Bit	Type	Label	Description
0x51 STATUS_B	7	R	RAMP_READY_B	De-asserted during Buck A DVC, power up and power down
	6	R	RAMP_READY_A	De-asserted during Buck B DVC, power up and power down
	5	R	OV_CURR_B	Asserted as long as the current limit for Buck B is hit
	4	R	OV_CURR_A	Asserted as long as the current limit for Buck A is hit
	3	R	TEMP_CRIT	Asserted as long as the thermal shutdown threshold is reached
	2	R	TEMP_WARN	Asserted as long as the thermal warning threshold is reached
	1	R	PWRGOOD_B	Asserted as long as the Buck B output voltage is in range

Multi-Phase 5A/Phase DC-DC Buck Converter

Register	Bit	Type	Label	Description
	0	R	PWRGOOD_A	Asserted as long as the Buck A output voltage is in range

The EVENT registers hold information about events that have occurred in DA9213, DA9214, and DA9215. Events are triggered by a change in the status register which contains the status of monitored signals. When an EVENT bit is set in the event register, the IRQ signal is asserted unless the event is masked by a bit in the mask register. **The IRQ triggering event register will be cleared from the host by writing back its read value.** New events occurring during clearing will be delayed before they are passed to the event register, ensuring that the host controller does not miss them.

Register	Bit	Type	Label	Description
0x52 EVENT_A	7	R	(reserved)	
	6	R	E_UVLO_IO	UVLO_IO caused event
	5	R	(reserved)	
	4	R	E_GPI4	GPI4 event according to active state setting
	3	R	E_GPI3	GPI3 event according to active state setting
	2	R	E_GPI2	GPI2 event according to active state setting
	1	R	E_GPI1	GPI1 event according to active state setting
	0	R	E_GPI0	GPI0 event according to active state setting

Register	Bit	Type	Label	Description
0x53 EVENT_B	7:6	R	(reserved)	
	5	R	E_OV_CURR_B	OV_CURR Buck B caused event
	4	R	E_OV_CURR_A	OV_CURR Buck A caused event
	3	R	E_TEMP_CRIT	TEMP_CRIT caused event
	2	R	E_TEMP_WARN	TEMP_WARN caused event
	1	R	E_PWRGOOD_B	PWRGOOD loss at Buck B caused event
	0	R	E_PWRGOOD_A	PWRGOOD loss at Buck A caused event

Register	Bit	Type	Label	Description
0x54 MASK_A	7	R/W	(reserved)	
	6	R/W	M_UVLO_IO	Mask UVLO_IO caused nIRQ
	5	R/W	(reserved)	
	4	R/W	M_GPI4	Mask nIRQ interrupt at GPI4
	3	R/W	M_GPI3	Mask nIRQ interrupt at GPI3
	2	R/W	M_GPI2	Mask nIRQ interrupt at GPI2
	1	R/W	M_GPI1	Mask nIRQ interrupt at GPI1
	0	R/W	M_GPI0	Mask nIRQ interrupt at GPI0

Register	Bit	Type	Label	Description
0x55	7:6	R/W	(reserved)	

Multi-Phase 5A/Phase DC-DC Buck Converter

Register	Bit	Type	Label	Description
MASK_B	5	R/W	M_OV_CURR_B	Mask OV_CURR Buck B caused nIRQ and event
	4	R/W	M_OV_CURR_A	Mask OV_CURR Buck A caused nIRQ and event
	3	R/W	M_TEMP_CRIT	Mask TEMP_CRIT caused nIRQ
	2	R/W	M_TEMP_WARN	Mask TEMP_WARN caused nIRQ
	1	R/W	M_PWRGOOD_B	Mask PWRGOOD Buck B caused nIRQ
	0	R/W	M_PWRGOOD_A	Mask PWRGOOD Buck A caused nIRQ

Register	Bit	Type	Label	Description
0x56 CONTROL_A	7	R/W	V_LOCK	0: Allows host writes into registers 0xD0 to 0x14F 1: Disables register 0xD0 to 0x14F re-programming from control interfaces
	6:5	R/W	SLEW_RATE_B	Buck B DVC slewing is executed at 00: 10 mV every 4.0 μ s 01: 10 mV every 2.0 μ s 10: 10 mV every 1.0 μs 11: 10 mV every 0.5 μ s
	4:3	R/W	SLEW_RATE_A	Buck A DVC slewing is executed at 00: 10 mV every 4.0 μ s 01: 10 mV every 2.0 μ s 10: 10 mV every 1.0 μs 11: 10 mV every 0.5 μ s
	0:2	R/W	DEBOUNCE	Input signals debounce time: 000: no debounce time 001: 0.1 ms 010: 1.0 ms 011: 10 ms 100: 50 ms 101: 250 ms 110: 500 ms 111: 1000 ms

8.1.2.2 GPIO Control

Register	Bit	Type	Label	Description
0x58 GPIO-1	7	R/W	GPI1_MODE	0: GPI: debouncing off 1: GPI: debouncing on
	6	R/W	GPI1_TYPE	0: GPI: active low 1: GPI: active high
	5:4	R/W	GPI1_PIN	PIN assigned to: 00: GPI >00: Reserved
	3	R/W	GPIO_MODE	0: GPI: debouncing off

Multi-Phase 5A/Phase DC-DC Buck Converter

Register	Bit	Type	Label	Description
				1: GPI: debouncing on
	2	R/W	GPI0_TYPE	0: GPI: active low 1: GPI: active high
	1:0	R/W	GPI0_PIN	PIN assigned to: 00: GPI 01: Track enable 1x: Reserved

Register	Bit	Type	Label	Description
0x59 GPIO2-3	7	R/W	GPIO3_MODE	0: GPI: debouncing off GPO: Sets output to passive level 1: GPI: debouncing on GPO: Sets output to active level
	6	R/W	GPIO3_TYPE	0: GPI/GPO: active low 1: GPI/GPO: active high
	5:4	R/W	GPIO3_PIN	PIN assigned to: 00: GPI 01: Reserved 10: GPO (Open drain) 11: GPO (Push-pull)
	3	R/W	GPIO2_MODE	0: GPI: debouncing off GPO: Sets output to passive level 1: GPI: debouncing on GPO: Sets output to active level
	2	R/W	GPIO2_TYPE	0: GPI/GPO: active low 1: GPI/GPO: active high
	1:0	R/W	GPIO2_PIN	PIN assigned to: 00: GPI 01: Reserved 10: GPO (Open drain) 11: GPO (Push-pull)

Register	Bit	Type	Label	Description
0x5A GPI4	7:4	R/W	(reserved)	
	3	R/W	GPI4_MODE	0: GPI: debouncing off 1: GPI: debouncing on
	2	R/W	GPI4_TYPE	0: GPI: active low 1: GPI: active high
	1:0	R/W	GPI4_PIN	PIN assigned to: 00: GPI 01: Reserved 1x: Reserved

Multi-Phase 5A/Phase DC-DC Buck Converter

8.1.2.3 Regulators Control

Register	Bit	Type	Label	Description
0x5D BUCKA_CONT	7	R/W	(reserved)	
	6:5	R/W	VBUCKA_GPI	Selects the GPI that specifies the target voltage of VBUCKA. This is VBUCKA_A on active to passive transition, VBUCKA_B on passive to active transition. Active high/low is controlled by GPIx_TYPE. 00: Not controlled by GPIO 01: GPIO1 controlled 10: GPIO2 controlled 11: GPIO4 controlled
	4	R/W	VBUCKA_SEL	Buck A voltage is selected from (ramping): 0: VBUCKA_A 1: VBUCKA_B
	3	R/W	BUCKA_PD_DIS	0: Enable pull-down resistor of Buck A when the buck is disabled 1: Disable pull-down resistor of Buck A when the buck is disabled
	2:1	R/W	BUCKA_GPI	GPIO enables the Buck A on passive to active state transition, disables the Buck A on active to passive state transition 00: Not controlled by GPIO 01: GPIO0 controlled 10: GPIO1 controlled 11: GPIO3 controlled
	0	R/W	BUCKA_EN	0: Buck A disabled 1: Buck A enabled

Register	Bit	Type	Label	Description
0x5E BUCKB_CONT	7	R/W	(reserved)	
	6:5	R/W	VBUCKB_GPI	Selects the GPI that specifies the target voltage of VBUCKB. This is VBUCKB_A on active to passive transition, VBUCKB_B on passive to active transition. Active high/low is controlled by GPIx_TYPE. 00: Not controlled by GPIO 01: GPIO1 controlled 10: GPIO2 controlled 11: GPIO4 controlled
	4	R/W	VBUCKB_SEL	Buck A voltage is selected from (ramping): 0: VBUCKB_A 1: VBUCKB_B
	3	R/W	BUCKB_PD_DIS	0: Enable pull-down resistor of Buck B when the buck is disabled 1: Disable pull-down resistor of Buck B when the buck is disabled

Multi-Phase 5A/Phase DC-DC Buck Converter

Register	Bit	Type	Label	Description
	2:1	R/W	BUCKB_GPI	GPIO enables the Buck B on passive to active state transition, disables the Buck B on active to passive state transition 00: Not controlled by GPIO 01: GPIO0 controlled 10: GPIO1 controlled 11: GPIO3 controlled
	0	R/W	BUCKB_EN	0: Buck B disabled 1: Buck B enabled

8.1.3 Register Page 1

Register	Bit	Type	Label	Description
0x80 PAGE_CON	7	R/W	REVERT	Resets REG_PAGE to 000 after read/write access has finished
	6	R/W	WRITE_MODE	2-WIRE multiple write mode 0: Page Write Mode 1: Repeated Write Mode
	5:3	R/W	(reserved)	
	2:0	R/W	REG_PAGE	I ² C 00x: Selects Register 0x00 to 0xFF 01x: Selects Register 0x100 to 0x17F SPI 000: Selects Register 0x00 to 0x7F 001: Selects Register 0x80 to 0xFF 010: Selects Register 0x100 to 0x17F >010: Reserved for production and test

8.1.3.1 Regulators Settings

Register	Bit	Type	Label	Description
0xD0 BUCK_ILIM	7:4	R/W	BUCKB_ILIM	Current limit per phase: 0000: 4000 mA 0001: 4200 mA 0010: 4400 mA Continuing through... 1001: 5800 mA to... 1110: 6800 mA 1111: 7000 mA
	3:0	R/W	BUCKA_ILIM	Current limit per phase: 0000: 4000 mA 0001: 4200 mA 0010: 4400 mA

Multi-Phase 5A/Phase DC-DC Buck Converter

Register	Bit	Type	Label	Description
				Continuing through... 1001: 5800 mA to... 1110: 6800 mA 1111: 7000 mA

Register	Bit	Type	Label	Description			
0xD1 BUCKA_CONF	7:5	R/W	BUCKA_DOW N_CTRL	Buck A voltage ramping during power down 000: 1.25 mV/μs 001: 2.5 mV/μs 010: 5 mV/μs 011: 10 mV/μs 100: 20 mV/μs 101: 30 mV/μs 110: 40 mV/μs 111: no ramped power down			
				4:2	R/W	BUCKA_UP_C TRL	Buck A voltage ramping during start up 000: 1.25 mV/μs 001: 2.5 mV/μs 010: 5 mV/μs 011: 10 mV/μs 100: 20 mV/μs (Note 1) 101: 30 mV/μs 110: 40 mV/μs 111: target voltage applied immediately (no soft start)
							1:0

Note 1 Settings higher than 20 mV/μs may cause significant overshoot

Register	Bit	Type	Label	Description
0xD2 BUCKB_CONF	7:5	R/W	BUCKB_DOW N_CTRL	Buck B voltage ramping during power down 000: 1.25 mV/μs 001: 2.5 mV/μs 010: 5 mV/μs 011: 10 mV/μs 100: 20 mV/μs 101: 30 mV/μs 110: 40 mV/μs 111: no ramped power down
				4:2

Multi-Phase 5A/Phase DC-DC Buck Converter

Register	Bit	Type	Label	Description
				001: 2.5 mV/μs 010: 5 mV/μs 011: 10 mV/μs 100: 20 mV/μs (Note 2) 101: 30 mV/μs 110: 40 mV/μs 111: target voltage applied immediately (no soft start)
	1:0	R/W	BUCKB_MODE	00: PFM/PWM mode controlled via voltage A and B registers 01: Automatic mode (1-phase) 10: Buck B always operates in PWM mode 11: Automatic mode

Note 2 Settings higher than 20 mV/μs may cause significant overshoot

Register	Bit	Type	Label	Description
0xD3 BUCK_CONF	7:5	R/W	(reserved)	
	4	R/W	PH_SH_EN_B	Enable current dependent phase shedding in PWM for Buck B
	3	R/W	PH_SH_EN_A	Enable current dependent phase shedding in PWM for Buck A
	2	R/W	PHASE_SEL_B	Phase selection for Buck B in PWM 0: 1 phase is selected 1: 2 phases are selected
	1:0	R/W	PHASE_SEL_A	Phase selection for Buck A in PWM mode. Settings >01 apply only for DA9213 otherwise the number of phases is limited to max 2 00: 1 phase is selected 01: 2 phases are selected 10: 3 phases are selected (uneven 0/90/180 phase shift) 11: 4 phases are selected

Register	Bit	Type	Label	Description
0xD5 VBUCKA_MAX	7	R/W	(reserved)	
	6:0	R	VBUCKA_MAX	Sets the maximum voltage allowed for Buck A (OTP programmed, access only in test mode) 0000000: 0.30 V 0000001: 0.31 V 0000010: 0.32 V Continuing through... 1000110: 1.0 V to...

Multi-Phase 5A/Phase DC-DC Buck Converter

Register	Bit	Type	Label	Description
				1111101: 1.55 V 1111110: 1.56 V 1111111: 1.57 V

Register	Bit	Type	Label	Description
0xD6 VBUCKB_MAX	7	R/W	(reserved)	
	6:0	R	VBUCKB_MAX	Sets the maximum voltage allowed for Buck B (OTP programmed, access only in test mode) 0000000: 0.30 V 0000001: 0.31 V 0000010: 0.32 V Continuing through... 1000110: 1.0 V to... 1111101: 1.55 V 1111110: 1.56 V 1111111: 1.57 V

Register	Bit	Type	Label	Description
0xD7 VBUCKA_A	7	R/W	BUCKA_SL_A	0: Configures Buck A to PWM mode whenever selecting A voltage setting 1: Configures Buck A to automatic mode whenever selecting A voltage setting
	6:0	R/W	VBUCKA_A	0000000: 0.30 V 0000001: 0.31 V 0000010: 0.32 V Continuing through... 1000110: 1.0 V to... 1111101: 1.55 V 1111110: 1.56 V 1111111: 1.57 V

Register	Bit	Type	Label	Description
0xD8 VBUCKA_B	7	R/W	BUCKA_SL_B	0: Configures Buck A to PWM mode, whenever selecting B voltage setting 1: Configures Buck A to automatic mode, whenever selecting B voltage setting

Multi-Phase 5A/Phase DC-DC Buck Converter

Register	Bit	Type	Label	Description
	6:0	R/W	VBUCKA_B	0000000: 0.30 V 0000001: 0.31 V 0000010: 0.32 V Continuing through... 1000110: 1.0 V to... 1111101: 1.55 V 1111110: 1.56 V 1111111: 1.57 V

Register	Bit	Type	Label	Description
0xD9 VBUCKB_A	7	R/W	BUCKB_SL_A	0: Configures Buck B to PWM mode, whenever selecting A voltage setting 1: Configures Buck B to automatic mode, whenever selecting A voltage setting
	6:0	R/W	VBUCKB_A	0000000: 0.30 V 0000001: 0.31 V 0000010: 0.32 V Continuing through... 1000110: 1.0 V to... 1111101: 1.55 V 1111110: 1.56 V 1111111: 1.57 V

Register	Bit	Type	Label	Description
0xDA VBUCKB_B	7	R/W	BUCKB_SL_B	0: Configures Buck B to PWM mode, whenever selecting B voltage setting 1: Configures Buck B to automatic mode, whenever selecting B voltage setting
	6:0	R/W	VBUCKB_B	0000000: 0.30 V 0000001: 0.31 V 0000010: 0.32 V Continuing through... 1000110: 1.0 V to... 1111101: 1.55 V 1111110: 1.56 V

Multi-Phase 5A/Phase DC-DC Buck Converter

Register	Bit	Type	Label	Description
				1111111: 1.57 V

8.1.4 Register Page 2

Register	Bit	Type	Label	Description
0x100 PAGE_CON	7	R/W	REVERT	Resets REG_PAGE to 000 after read/write access has finished
	6	R/W	WRITE_MODE	2-WIRE multiple write mode 0: Page Write Mode 1: Repeated Write Mode
	5:3	R/W	(reserved)	
	2:0	R/W	REG_PAGE	I ² C 00x: Selects Register 0x00 to 0xFF 01x: Selects Register 0x100 to 0x17F SPI 000: Selects Register 0x00 to 0x7F 001: Selects Register 0x80 to 0xFF 010: Selects Register 0x100 to 0x17F >010: Reserved for production and test

8.1.4.1 Interface and OTP Settings (shared with DA9063)

Register	Bit	Type	Label	Description
0x105 INTERFACE	7:4	R/W	IF_BASE_ADD R1	4 MSB of 2-WIRE control interfaces base address XXXX0000 11010000 = 0xD0 write address of PM 2-WIRE interface (page 0 and 1) 11010001 = 0xD1 read address of PM 2-WIRE interface (page 0 and 1) 11010010 = 0xD2 write address of PM-2-WIRE interface (page 2 and 3) 11010011 = 0xD3 read address of PM-2-WIRE interface (page 2 and 3) Code 0000 is reserved for unprogrammed OTP (triggers start-up with hardware default interface address)
	3	R/W	R/W_POL	4-WIRE: Read/Write bit polarity 0: Host indicates reading access via R/W bit = 0 1: Host indicates reading access via R/W bit = 1
	2	R/W	CPHA	4-WIRE interface clock phase (see Table 10)
	1	R/W	CPOL	4-WIRE interface clock polarity 0: SK is low during idle 1: SK is high during idle
	0	R/W	nCS_POL	4-WIRE chip select polarity 0: nCS is low active 1: nCS is high active

Multi-Phase 5A/Phase DC-DC Buck Converter

Register	Bit	Type	Label	Description
0x106 INTERFACE2	7	R/W	IF_TYPE	0: Power manager interface is 4-WIRE. Automatically configures GPIO3 and GPI4 as interface signals. The GPIO configuration is overruled. 1: Power manager interface is 2-WIRE
	6	R/W	PM_IF_HSM	Enables continuous high speed mode on 2-WIRE interface if asserted (no master code required)
	5	R/W	PM_IF_FMP	Enables 2-WIRE interface operating with fast mode+ timings if asserted
	4	R/W	PM_IF_V	0: Power manager interface in 2-WIRE mode is supplied from VDDCORE (4-WIRE always from VDDIO) 1: Power manager interface in 2-WIRE mode is supplied from VDDIO (4-WIRE always from VDDIO)
	0:3	R/W	(reserved)	

8.1.4.2 Application Configuration Settings

Register	Bit	Type	Label	Description
0x143 CONFIG_A	7:5	R/W	(reserved)	
	4	R/W	2WIRE_TO	Enables automatic reset of 2-WIRE interface if the clock stays low for >35 ms 0: Disabled 1: Enabled
	3	R/W	GPI_V	GPIs are supplied from: 0: VDDCORE 1: VDDIO
	2	R/W	(reserved)	
	1	R/W	IRQ_TYPE	nIRQ output port is: 0: Push-pull 1: Open drain (requires external pull-up resistor)
	0	R/W	IRQ_LEVEL	nIRQ output port is: 0: Active low 1: Active high

Register	Bit	Type	Label	Description
0x144 CONFIG_B	7	R/W	UVLO_IO_DIS	Disable the UVLO for the VDDIO rail and its comparator (suggested for rail voltages different to 1.8 V and to save quiescent current)
	6	R/W	PGB_DVC_MASK	Power-good configuration for Buck B 0: Power-good signal not masked during DVC transitions 1: Power-good signal masked during DVC transitions (keep previous status)
	5	R/W	PGA_DVC_MASK	Power-good configuration for Buck A

Multi-Phase 5A/Phase DC-DC Buck Converter

Register	Bit	Type	Label	Description
				0: Power-good signal not masked during DVC transitions 1: Power-good signal masked during DVC transitions (keep previous status)
	4:3	R/W	OCB_MASK	Over Current configuration for Buck B 00: Event generation due to over current hit is always active during DVC transitions of the Buck converter 01: Event generation due to over current hit is masked during DVC transitions of the buck converter + 2 μ s extra masking at the end 10: Event generation due to over current hit is masked during DVC transitions of the buck converter + 10 μ s extra masking at the end 11: Event generation due to over current hit is masked during DVC transitions of the buck converter + 50 μ s extra masking at the end
	2:1	R/W	OCA_MASK	Over Current configuration for Buck A 00: Event generation due to over current hit is always active during DVC transitions of the buck converter 01: Event generation due to over current hit is masked during DVC transitions of the buck converter + 2 μ s extra masking at the end 10: Event generation due to over current hit is masked during DVC transitions of the buck converter + 10 μ s extra masking at the end 11: Event generation due to over current hit is masked during DVC transitions of the buck converter + 50 μ s extra masking at the end
	0	R/W	RELOAD_FUNC_EN	Enable the OTP re-load function for GPIO0 when configured as input port

Register	Bit	Type	Label	Description
0x145 CONFIG_C	7:5	R/W	(reserved)	
	4	R/W	GPI4_PUPD	0: GPI: pull-down resistor disabled 1: GPI: pull-down resistor enabled
	3	R/W	GPIO3_PUPD	0: GPI: pull-down resistor disabled GPO (open drain): pull up resistor disabled (external pull-up resistor) 1: GPI: pull-down resistor enabled GPO (open drain): pull up resistor
	2	R/W	GPIO2_PUPD	0: GPI: pull-down resistor disabled GPO (open drain): pull up resistor disabled (external pull-up resistor) 1: GPI: pull-down resistor enabled GPO (open drain): pull up resistor enabled
	1	R/W	GPI1_PUPD	0: GPI: pull-down resistor disabled 1: GPI: pull-down resistor enabled

Multi-Phase 5A/Phase DC-DC Buck Converter

Register	Bit	Type	Label	Description
	0	R/W	GPI0_PUPD	0: GPI: pull-down resistor disabled 1: GPI: pull-down resistor enabled

Register	Bit	Type	Label	Description
0x146 CONFIG_D	7:6	R/W	BUCKB_PG_SEL	Selection of the PG signal for Buck B 00: none 01: GPO2 10: GPO3 11: reserved
	5:4	R/W	BUCKA_PG_SEL	Selection of the PG signal for Buck A 00: none 01: GPO2 10: GPO3 11: reserved
	3:2	R/W	READYB_CONF	Selection of the READY signal for Buck B 00: none 01: GPO2 10: GPO3 11: reserved
	1:0	R/W	READYA_CONF	Selection of the READY signal for Buck A 00: none 01: GPO2 10: GPO3 11: reserved

Register	Bit	Type	Label	Description
0x147 CONFIG_E	7	R/W	STAND_ALONE	0: DA9213, DA9214, and DA9215 is used as companion IC to DA9063 or DA9063-compliant 1: DA9213, DA9214, and DA9215 is standalone or as companion IC with another PMU not DA9063-compliant
	6:5	R/W	(reserved)	
	4:3	R/W	(reserved)	
	2:0	R/W	OSC_TUNE	Tune the main 6 MHz oscillator frequency: 000: no tune 001: +180 kHz 010: +360 kHz 011: +540 kHz 100: +720 kHz 101: +900 kHz 110: +1080 kHz 111: +1260 kHz

Multi-Phase 5A/Phase DC-DC Buck Converter

Register	Bit	Type	Label	Description
0x148 CONFIG_F	7:4	R/W	IF_BASE_ADDR2	<p>If a second I²C address is to be selected on ADDR_SEL_CONF, this field configures the second address.</p> <p>4 MSB of 2-WIRE control interfaces base address XXXX0000</p> <p>11010000 = 0xD0 write address of PM 2-WIRE interface (page 0 and 1)</p> <p>11010001 = 0xD1 read address of PM 2-WIRE interface (page 0 and 1)</p> <p>11010010 = 0xD2 write address of PM-2-WIRE interface (page 2 and 3)</p> <p>11010011 = 0xD3 read address of PM-2-WIRE interface (page 2 and 3)</p> <p>Code 0000 is reserved for unprogrammed OTP (triggers start-up with hardware default interface address)</p>
	3:2	R	(reserved)	
	1	R/W	ADDR_SEL_CONF	<p>Selects the GPI for the alternative I²C address selection:</p> <p>00: none</p> <p>01: GPIO</p> <p>10: GPI1</p> <p>11: GPI4</p>

Multi-Phase 5A/Phase DC-DC Buck Converter

9 Application Information

The following recommended components are examples selected from requirements of a typical application.

9.1 Capacitor Selection

Ceramic capacitors are used as bypass capacitors at all VDD and output rails. When selecting a capacitor, especially for types with high capacitance at smallest physical dimension, the DC bias characteristic has to be taken into account.

Table 14: Recommended Capacitor Types

Application	Value	Size	Temp Char	Tol (%)	V-Rate	Type
VOUT output bypass	47 μ F	0603	X5R \pm 15 %	\pm 20	6.3 V	Murata GRM188R60J476ME15
	47 μ F	0805	X5R \pm 15 %	\pm 20	10 V	Murata GRM21BR61A476ME15
	22 μ F	0603	X5R \pm 15 %	\pm 20	10 V	Murata GRM188R61A226ME15
VDDx bypass	22 μ F	0402	X5R \pm 15 %	\pm 20	4 V	Semco CL05A226MR5NZNC
	10 μ F	0402	X5R \pm 15 %	\pm 20	10 V	Semco CL05A106MP5NUNC
	10 μ F	0603	X5R \pm 15 %	\pm 10	10 V	Murata GRM188R61A105KAAL
VSYS bypass	1 μ F	0402	X5R \pm 15 %	\pm 10	10 V	Murata GRM155R61A105KE15
VDDIO bypass	100 nF	01005	X5R \pm 15 %	\pm 10	6.3 V	Semco CL02A104KQ2NNN

Multi-Phase 5A/Phase DC-DC Buck Converter

9.2 Inductor Selection

Inductors should be selected based upon the following parameters:

- Rated max. current: usually a coil provides two current limits: The I_{sat} specifies the maximum current at which the inductance drops by 30 % of the nominal value. The I_{max} is defined by the maximum power dissipation and is applied to the effective current.
- DC resistance: critical for the converter efficiency and should therefore be minimized.
- The typical recommended output inductance is 0.22 μH per phase. Use of larger output inductance degrades the load transient performance of the buck converter.

Table 15: Recommended Inductor Types

Value (μH)	Size (mm)	$I_{max}(dc)$ (A)	I_{sat} (A)	Tol (%)	DC Res ($m\Omega$)	Type
0.47	2.0 x 1.6 x 1.0	4.7	6.2	± 20	26	Semco CIGT201610EHR47MLE
0.47	2.5 x 2.0 x 0.8	5.5	5.5	± 20	15	Semco CIGT252008 EHR47MNE
0.24	2.5 x 2.0 x 1.0	5.7	5.7	± 20	10	Semco CIGT252010 LMR24MNE
0.24	2.5 x 2.0 x 1.2	6.6	6.6	± 20	8	Semco CIGT252012 LMR24MNE
0.47	2.5 x 2.0 x 1.0	4.1	5.3	± 20	28	TOKO DFE252010P-H-R47M
0.47	2.5 x 2.0 x 1.2	4.7	6.1	± 20	21	TOKO DFE252012P-H-R47M
0.33	2.5 x 2.0 x 1.0	4.4	5.8	± 20	22	TOKO DFE252010P-H-R33M
0.33	2.5 x 2.0 x 1.2	5.0	6.4	± 20	18	TOKO DFE252012P-H-R33M
0.47	2.5 x 2.0 x 1.2	4.7	5.2	± 20	19	Cyntec HMLE25201B-R47MS
0.22	2.5 x 2.0 x 1.2	7.3	7.0	± 20	8	Cyntec PIFE25201B
0.22	2.5 x 2.0 x 1.0	6.6	5.8	± 20	10	Cyntec PIFE25201T-R22MS
0.47	4 x 4 x 1.0	9.0	10.5	± 20	17	Cyntec PIME041B-R47MS-11
0.47	2.5 x 2.0 x 1.2	3.9	4.8	± 20	30	Taiyo Yuden MAMK2520T R47M
0.47	4 x 4 x 1.2	8.7	6.7	± 20	14	Coilcraft XFL4012-471ME

Multi-Phase 5A/Phase DC-DC Buck Converter

10 Package Information

10.1 Package Outlines

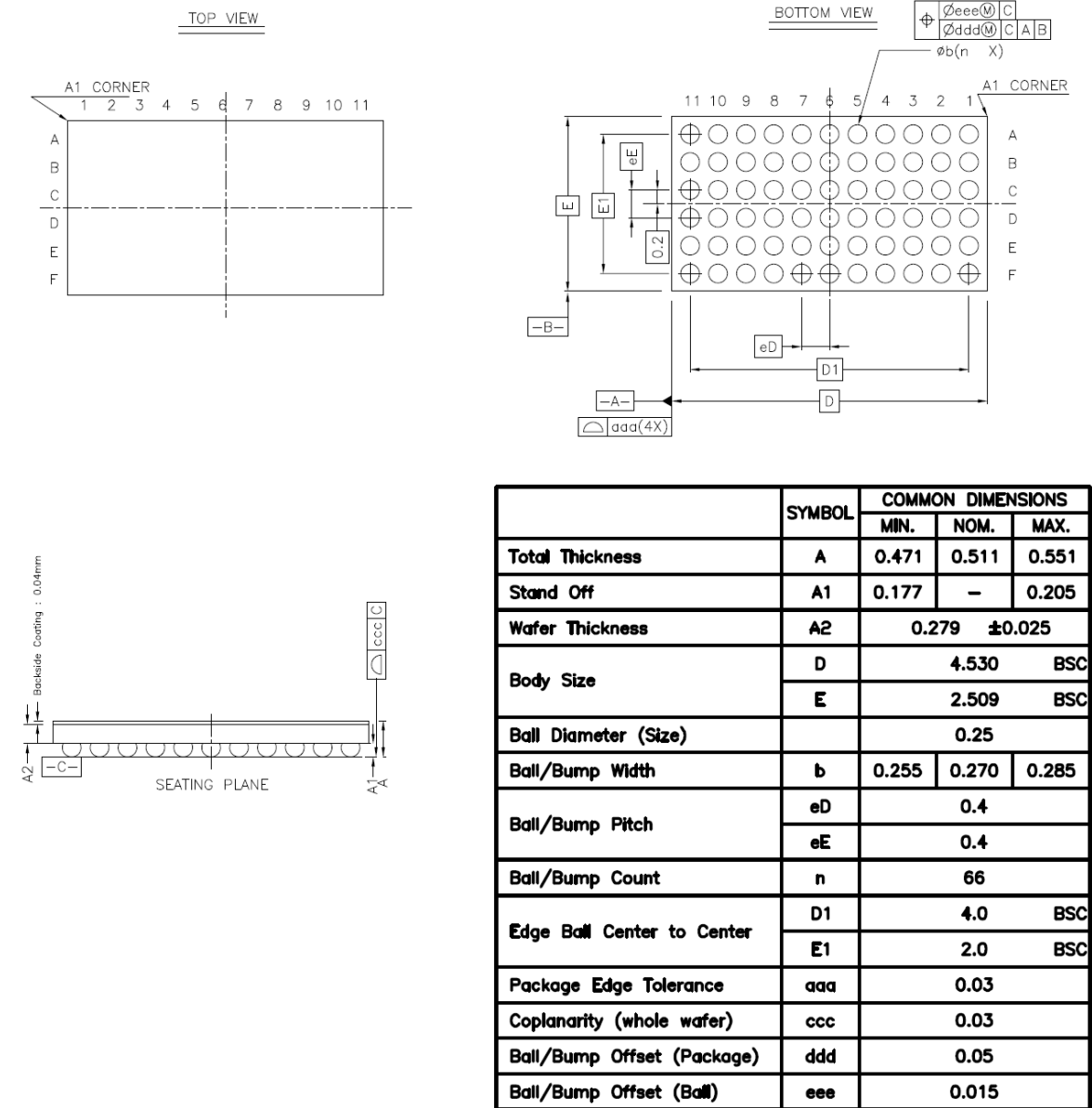

Figure 31: DA9213/14/15 66 WL-CSP Package Outline Drawing

Multi-Phase 5A/Phase DC-DC Buck Converter

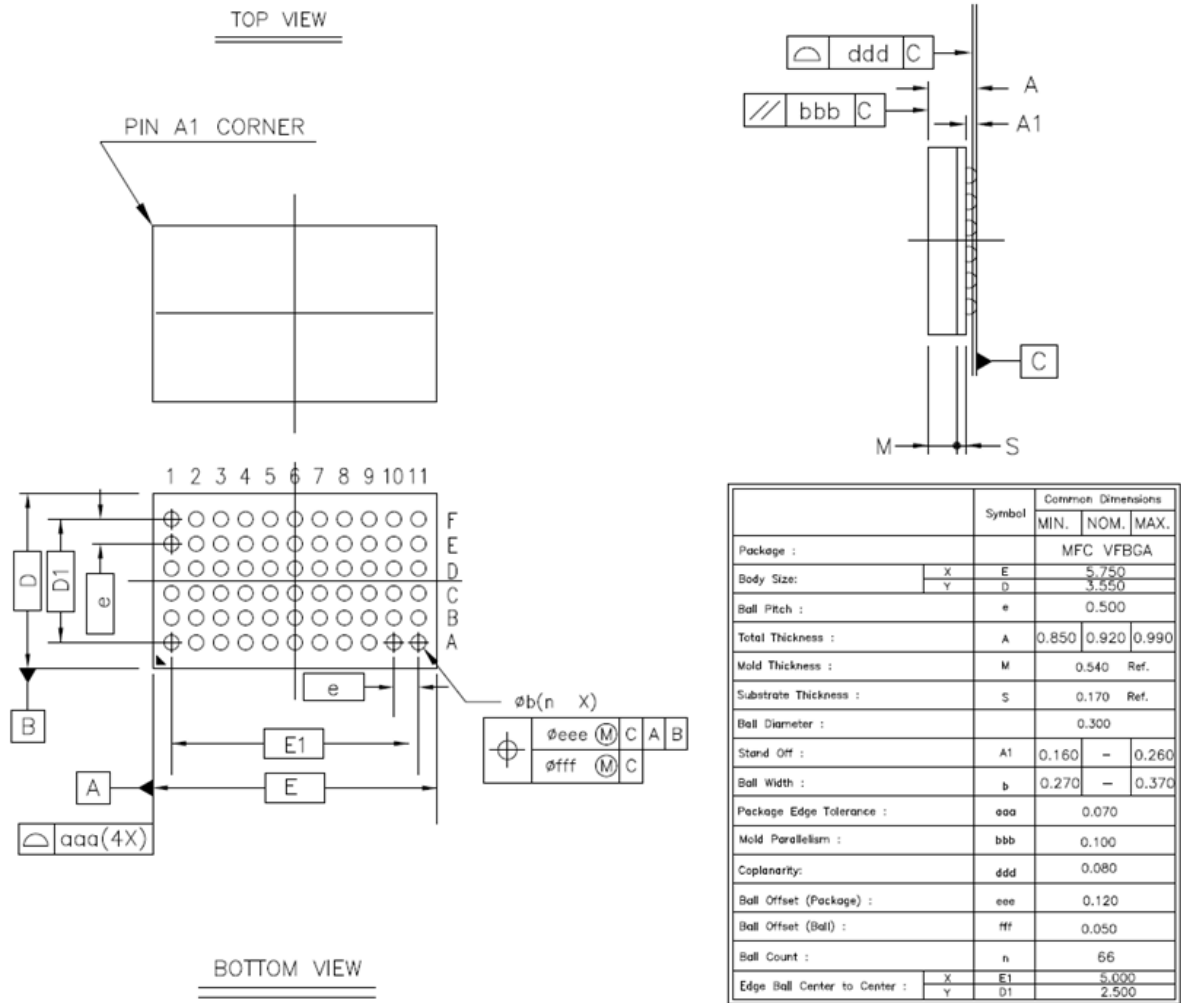

Figure 32: DA9213/14/15 66 VFBGA Package Outline Drawing

Multi-Phase 5A/Phase DC-DC Buck Converter

11 Ordering Information

The ordering number consists of the part number followed by a suffix indicating the packing method. For details and availability, please consult Dialog Semiconductor's [website](#) or your local sales representative.

Table 16: Ordering Information

Part Number	Package	Package Description	Package Outline
DA9213-xxUP2	66 WL-CSP	T&R, 5000pcs	Figure 31
DA9213-xxUP6	66 WL-CSP	Waffle	
DA9214-xxUP2	66 WL-CSP	T&R, 5000pcs	
DA9214-xxUP6	66 WL-CSP	Waffle	
DA9215-xxUP2	66 WL-CSP	T&R, 5000pcs	
DA9215-xxUP6	66 WL-CSP	Waffle	
DA9213-xxFS1BB	66 VFBGA	Tray	Figure 32
DA9213-xxFS2BB, Note 1	66 VFBGA	T&R, 5000pcs	
DA9213-xxFSBB	66 VFBGA	T&R, 1100pcs	
DA9214-xxFS1BB	66 VFBGA	Tray	
DA9214-xxFS2BB, Note 1	66 VFBGA	T&R, 5000pcs	
DA9214-xxFSCBB	66 VFBGA	T&R, 1100pcs	
DA9215-xxFS1BB	66 VFBGA	Tray	
DA9215-xxFS2BB, Note 1	66 VFBGA	T&R, 5000pcs	
DA9215-xxFSCBB	66 VFBGA	T&R, 1100pcs	

Note 1 Large reel sizes are no longer supported, contact sales for further information

Multi-Phase 5A/Phase DC-DC Buck Converter**Status Definitions**

Revision	Datasheet Status	Product Status	Definition
1.<n>	Target	Development	This datasheet contains the design specifications for product development. Specifications may be changed in any manner without notice.
2.<n>	Preliminary	Qualification	This datasheet contains the specifications and preliminary characterization data for products in pre-production. Specifications may be changed at any time without notice in order to improve the design.
3.<n>	Final	Production	This datasheet contains the final specifications for products in volume production. The specifications may be changed at any time in order to improve the design, manufacturing and supply. Major specification changes are communicated via Customer Product Notifications. Datasheet changes are communicated via www.dialog-semiconductor.com .
4.<n>	Obsolete	Archived	This datasheet contains the specifications for discontinued products. The information is provided for reference only.

RoHS Compliance

Dialog Semiconductor's suppliers certify that its products are in compliance with the requirements of Directive 2011/65/EU of the European Parliament on the restriction of the use of certain hazardous substances in electrical and electronic equipment. RoHS certificates from our suppliers are available on request.

IMPORTANT NOTICE AND DISCLAIMER

RENESAS ELECTRONICS CORPORATION AND ITS SUBSIDIARIES (“RENESAS”) PROVIDES TECHNICAL SPECIFICATIONS AND RELIABILITY DATA (INCLUDING DATASHEETS), DESIGN RESOURCES (INCLUDING REFERENCE DESIGNS), APPLICATION OR OTHER DESIGN ADVICE, WEB TOOLS, SAFETY INFORMATION, AND OTHER RESOURCES “AS IS” AND WITH ALL FAULTS, AND DISCLAIMS ALL WARRANTIES, EXPRESS OR IMPLIED, INCLUDING, WITHOUT LIMITATION, ANY IMPLIED WARRANTIES OF MERCHANTABILITY, FITNESS FOR A PARTICULAR PURPOSE, OR NON-INFRINGEMENT OF THIRD-PARTY INTELLECTUAL PROPERTY RIGHTS.

These resources are intended for developers who are designing with Renesas products. You are solely responsible for (1) selecting the appropriate products for your application, (2) designing, validating, and testing your application, and (3) ensuring your application meets applicable standards, and any other safety, security, or other requirements. These resources are subject to change without notice. Renesas grants you permission to use these resources only to develop an application that uses Renesas products. Other reproduction or use of these resources is strictly prohibited. No license is granted to any other Renesas intellectual property or to any third-party intellectual property. Renesas disclaims responsibility for, and you will fully indemnify Renesas and its representatives against, any claims, damages, costs, losses, or liabilities arising from your use of these resources. Renesas' products are provided only subject to Renesas' Terms and Conditions of Sale or other applicable terms agreed to in writing. No use of any Renesas resources expands or otherwise alters any applicable warranties or warranty disclaimers for these products.

(Disclaimer Rev.1.01 Jan 2024)

Corporate Headquarters

TOYOSU FORESIA, 3-2-24 Toyosu,
Koto-ku, Tokyo 135-0061, Japan
www.renesas.com

Trademarks

Renesas and the Renesas logo are trademarks of Renesas Electronics Corporation. All trademarks and registered trademarks are the property of their respective owners.

Contact Information

For further information on a product, technology, the most up-to-date version of a document, or your nearest sales office, please visit www.renesas.com/contact-us/.