

To our customers,

Old Company Name in Catalogs and Other Documents

On April 1st, 2010, NEC Electronics Corporation merged with Renesas Technology Corporation, and Renesas Electronics Corporation took over all the business of both companies. Therefore, although the old company name remains in this document, it is a valid Renesas Electronics document. We appreciate your understanding.

Renesas Electronics website: <http://www.renesas.com>

April 1st, 2010
Renesas Electronics Corporation

Issued by: Renesas Electronics Corporation (<http://www.renesas.com>)

Send any inquiries to <http://www.renesas.com/inquiry>.

Notice

1. All information included in this document is current as of the date this document is issued. Such information, however, is subject to change without any prior notice. Before purchasing or using any Renesas Electronics products listed herein, please confirm the latest product information with a Renesas Electronics sales office. Also, please pay regular and careful attention to additional and different information to be disclosed by Renesas Electronics such as that disclosed through our website.
2. Renesas Electronics does not assume any liability for infringement of patents, copyrights, or other intellectual property rights of third parties by or arising from the use of Renesas Electronics products or technical information described in this document. No license, express, implied or otherwise, is granted hereby under any patents, copyrights or other intellectual property rights of Renesas Electronics or others.
3. You should not alter, modify, copy, or otherwise misappropriate any Renesas Electronics product, whether in whole or in part.
4. Descriptions of circuits, software and other related information in this document are provided only to illustrate the operation of semiconductor products and application examples. You are fully responsible for the incorporation of these circuits, software, and information in the design of your equipment. Renesas Electronics assumes no responsibility for any losses incurred by you or third parties arising from the use of these circuits, software, or information.
5. When exporting the products or technology described in this document, you should comply with the applicable export control laws and regulations and follow the procedures required by such laws and regulations. You should not use Renesas Electronics products or the technology described in this document for any purpose relating to military applications or use by the military, including but not limited to the development of weapons of mass destruction. Renesas Electronics products and technology may not be used for or incorporated into any products or systems whose manufacture, use, or sale is prohibited under any applicable domestic or foreign laws or regulations.
6. Renesas Electronics has used reasonable care in preparing the information included in this document, but Renesas Electronics does not warrant that such information is error free. Renesas Electronics assumes no liability whatsoever for any damages incurred by you resulting from errors in or omissions from the information included herein.
7. Renesas Electronics products are classified according to the following three quality grades: “Standard”, “High Quality”, and “Specific”. The recommended applications for each Renesas Electronics product depends on the product’s quality grade, as indicated below. You must check the quality grade of each Renesas Electronics product before using it in a particular application. You may not use any Renesas Electronics product for any application categorized as “Specific” without the prior written consent of Renesas Electronics. Further, you may not use any Renesas Electronics product for any application for which it is not intended without the prior written consent of Renesas Electronics. Renesas Electronics shall not be in any way liable for any damages or losses incurred by you or third parties arising from the use of any Renesas Electronics product for an application categorized as “Specific” or for which the product is not intended where you have failed to obtain the prior written consent of Renesas Electronics. The quality grade of each Renesas Electronics product is “Standard” unless otherwise expressly specified in a Renesas Electronics data sheets or data books, etc.
 - “Standard”: Computers; office equipment; communications equipment; test and measurement equipment; audio and visual equipment; home electronic appliances; machine tools; personal electronic equipment; and industrial robots.
 - “High Quality”: Transportation equipment (automobiles, trains, ships, etc.); traffic control systems; anti-disaster systems; anti-crime systems; safety equipment; and medical equipment not specifically designed for life support.
 - “Specific”: Aircraft; aerospace equipment; submersible repeaters; nuclear reactor control systems; medical equipment or systems for life support (e.g. artificial life support devices or systems), surgical implantations, or healthcare intervention (e.g. excision, etc.), and any other applications or purposes that pose a direct threat to human life.
8. You should use the Renesas Electronics products described in this document within the range specified by Renesas Electronics, especially with respect to the maximum rating, operating supply voltage range, movement power voltage range, heat radiation characteristics, installation and other product characteristics. Renesas Electronics shall have no liability for malfunctions or damages arising out of the use of Renesas Electronics products beyond such specified ranges.
9. Although Renesas Electronics endeavors to improve the quality and reliability of its products, semiconductor products have specific characteristics such as the occurrence of failure at a certain rate and malfunctions under certain use conditions. Further, Renesas Electronics products are not subject to radiation resistance design. Please be sure to implement safety measures to guard them against the possibility of physical injury, and injury or damage caused by fire in the event of the failure of a Renesas Electronics product, such as safety design for hardware and software including but not limited to redundancy, fire control and malfunction prevention, appropriate treatment for aging degradation or any other appropriate measures. Because the evaluation of microcomputer software alone is very difficult, please evaluate the safety of the final products or system manufactured by you.
10. Please contact a Renesas Electronics sales office for details as to environmental matters such as the environmental compatibility of each Renesas Electronics product. Please use Renesas Electronics products in compliance with all applicable laws and regulations that regulate the inclusion or use of controlled substances, including without limitation, the EU RoHS Directive. Renesas Electronics assumes no liability for damages or losses occurring as a result of your noncompliance with applicable laws and regulations.
11. This document may not be reproduced or duplicated, in any form, in whole or in part, without prior written consent of Renesas Electronics.
12. Please contact a Renesas Electronics sales office if you have any questions regarding the information contained in this document or Renesas Electronics products, or if you have any other inquiries.

(Note 1) “Renesas Electronics” as used in this document means Renesas Electronics Corporation and also includes its majority-owned subsidiaries.

(Note 2) “Renesas Electronics product(s)” means any product developed or manufactured by or for Renesas Electronics.

HA17901A Series

Quadruple Comparators

REJ03D0806-0100

Rev.1.00

Mar 10, 2006

Description

The HA17901A series products are comparators designed for general purpose, especially for power control systems.

These ICs operate from a single power-supply voltage over a wide range of voltages, and feature a reduced power-supply current since the supply current is independent of the supply voltage.

These comparators have the merit which ground is included in the common-mode input voltage range at a single-voltage power supply operation. These products have a wide range of applications, including limit comparators, simple A/D converters, pulse/square-wave/time delay generators, wide range VCO circuits, MOS clock timers, multivibrators, and high-voltage logic gates.

Features

- Wide power-supply voltage range : 2 to 36 V
- Very low supply current : 0.8 mA Typ.
- Low input bias current : 25 nA Typ.
- Low input offset current : 5 nA Typ.
- Low input offset voltage : 2 mV Typ.
- The common-mode input voltage range includes ground
- Output voltages compatible with CMOS logic systems

- Low electro-magnetic susceptibility

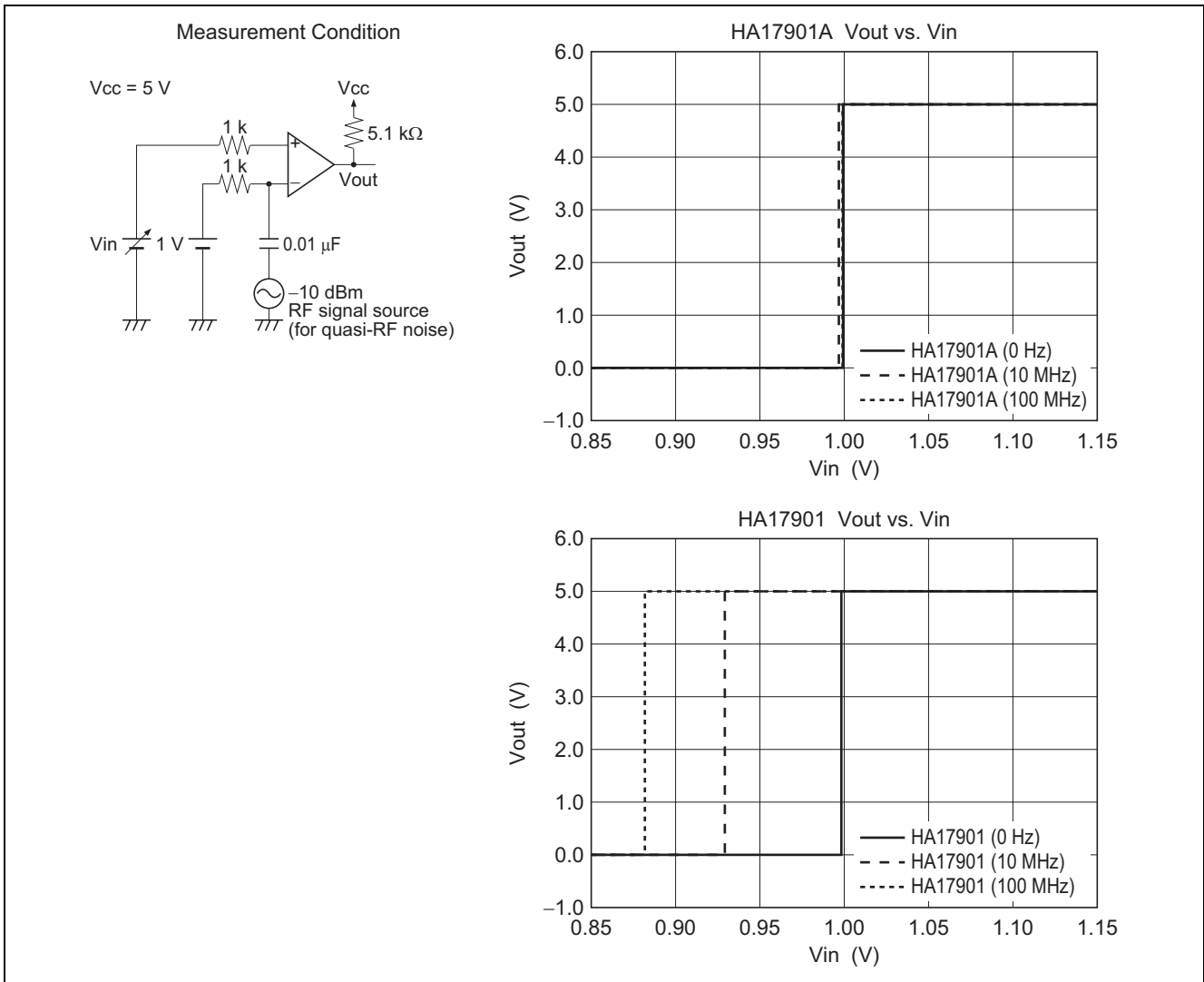

Ordering Information

Type No.	Application	Package Name	Package Code
HA17901AP	Industry use	DIP-14 pin	PRDP0014AB-B
HA17901AFP		SOP-14 pin (JEITA)	PRSP0014DF-B
HA17901ARP		SOP-14 pin (JEDEC)	PRSP0014DE-A
HA17901AT		TSSOP-14 pin	PTSP0014JA-B

Pin Arrangement

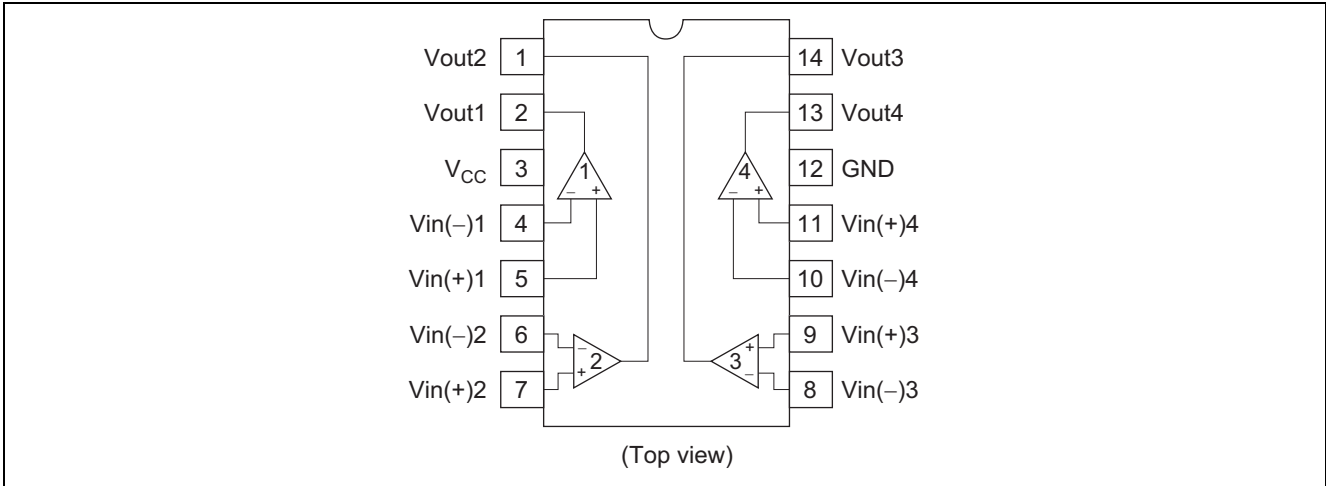

Circuit Structure (1/4)

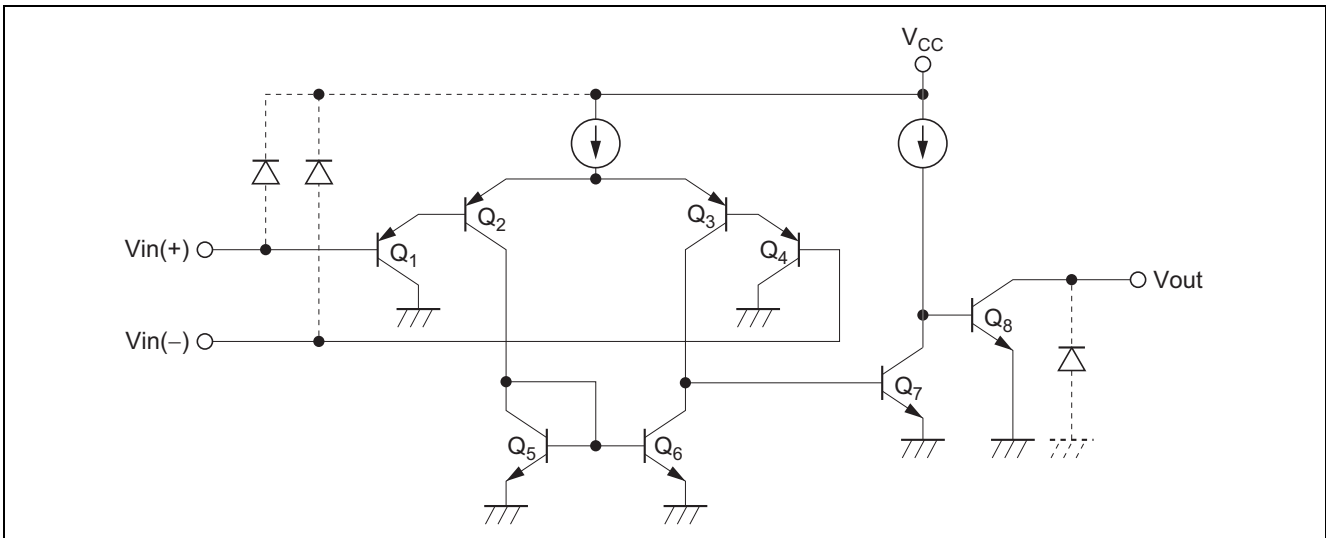

Note: If Input/Output terminals voltage over the absolute maximum ratings, there is possibility of mis-operation, characteristics deterioration and destruction, because of the current's flowing to parasitic diode in IC. The Input/Output terminals are recommended to be protected with the clamp circuit which using the diode with low forward voltage (like schottky barrier diode) when there is a possibility for the Input/Output terminals voltage exceeds the absolute maximum ratings.

Absolute Maximum Ratings

(Ta = 25°C)

Item	Symbol	Ratings	Unit
Power supply voltage	V _{CC}	36	V
Differential input voltage	V _{in(diff)}	±V _{CC}	V
Input voltage	V _{in}	-0.3 to +V _{CC}	V
Output pin voltage	V _{out}	-0.3 to +36	V
Output current	I _{out} *1	20	mA
Allowable power dissipation	DIP	P _T	625 *2
	SOP		625 *3
	TSSOP		400 *4
Operating temperature	Topr	-40 to +85	°C
Storage temperature	Tstg	-55 to +125	°C

- Notes: 1. These products can be destroyed if the output and V_{CC} are shorted together. The maximum output current is the allowable value for continuous operation.
2. HA17901AP:
These are the allowable values up to Ta = 50°C. Derate by 8.3 mW/°C above that temperature.
3. HA17901AFP/ARP:
When it is mounted on glass epoxy board of 40 mm × 40 mm × 1.6 mm with 10% wiring density, value at Ta ≤ 25°C. If Ta > 25°C, derated by 6.25 mW/°C.
When it is mounted on glass epoxy board of 40 mm × 40 mm × 1.6 mm with 30% wiring density. If Ta > 32°C, derated by 6.70 mW/°C.
4. HA17901AT:
These are the allowable values up to Ta = 25°C. Derate by 4 mW/°C above that temperature.

Electrical Characteristics

(V_{CC} = 5 V, Ta = 25°C)

Item	Symbol	Min	Typ	Max	Unit	Test Conditions
Input offset voltage	V _{IO}	—	2	7	mV	Output switching point: when V _O = 1.4V, R _S = 0Ω
Input offset current	I _{IO}	—	5	50	nA	I _{IN(+)} - I _{IN(-)}
Input bias current	I _{IB}	—	25	250	nA	I _{IN(+)} or I _{IN(-)}
Common-mode input voltage *1	V _{CM}	0	—	V _{CC} -1.5	V	
Supply current	I _{CC}	—	0.8	2	mA	R _L = ∞
Voltage Gain *3	A _V	—	(200)	—	V/mV	R _L = 15kΩ
Response time *2,3	t _R	—	(1.3)	—	μs	V _{RL} = 5V, R _L = 5.1kΩ
Output sink current	I _{O(sink)}	6	16	—	mA	V _{IN(-)} = 1V, V _{IN(+)} = 0, V _O ≤ 1.5V
Output saturation voltage	V _{O(sat)}	—	200	400	mV	V _{IN(-)} = 1V, V _{IN(+)} = 0, I _{osink} = 3mA
Output leakage current *3	I _{LO}	—	(0.1)	—	nA	V _{IN(+)} = 1V, V _{IN(-)} = 0, V _O = 5V

- Notes: 1. Voltages more negative than -0.3 V are not allowed for the common-mode input voltage or for either one of the input signal voltages.
2. The stipulated response time is the value for a 100 mV input step voltage that has a 5 mV overdrive.
3. Design spec.

Test Circuits

1. Input offset voltage (V_{IO}), input offset current (I_{IO}), and Input bias current (I_{IB}) test circuit

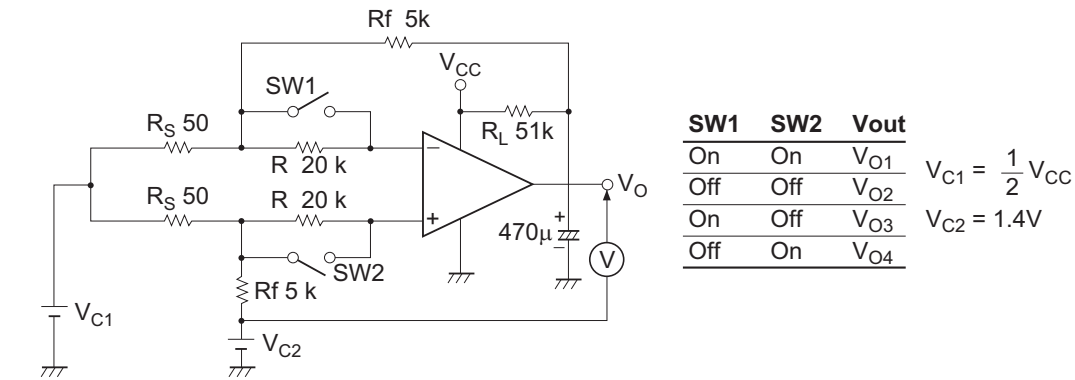

SW1	SW2	Vout
On	On	V_{O1}
Off	Off	V_{O2}
On	Off	V_{O3}
Off	On	V_{O4}

$$V_{C1} = \frac{1}{2} V_{CC}$$

$$V_{C2} = 1.4V$$

$$V_{IO} = \frac{|V_{O1}|}{1 + R_f / R_S} \quad (\text{mV})$$

$$I_{IO} = \frac{|V_{O2} - V_{O1}|}{R(1 + R_f / R_S)} \quad (\text{nA})$$

$$I_{IB} = \frac{|V_{O4} - V_{O3}|}{2 \cdot R(1 + R_f / R_S)} \quad (\text{nA})$$

2. Output saturation voltage ($V_{O\text{ sat}}$) output sink current (I_{osink}), and common-mode input voltage (V_{CM}) test circuit

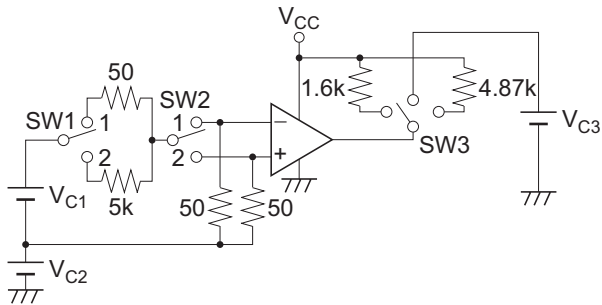

Item	V_{C1}	V_{C2}	V_{C3}	SW1	SW2	SW3	Unit
$V_{\text{O sat}}$	2V	0V	—	1	1	1 at $V_{CC} = 5V$ 3 at $V_{CC} = 15V$	V
I_{osink}	2V	0V	1.5V	1	1	2	mA
V_{CM}	2V	-1 to V_{CC}	—	2	Switched between 1 and 2	3	V

3. Supply current (I_{CC}) test circuit

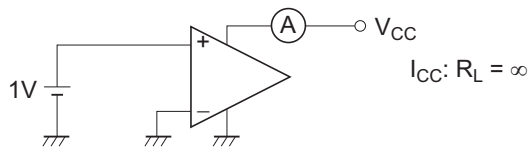

4. Voltage gain (A_V) test circuit ($R_L = 15\text{ k}\Omega$)

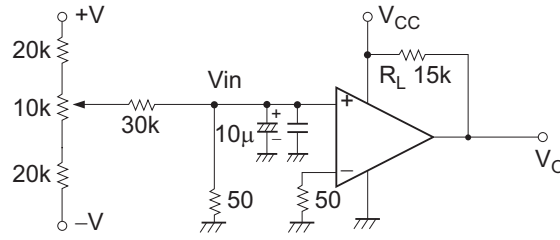

$$A_V = 20 \log \frac{V_{O1} - V_{O2}}{V_{IN1} - V_{IN2}} \quad (\text{dB})$$

5. Response time (t_R) test circuit

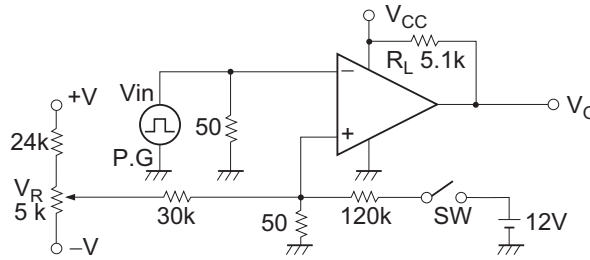

t_R : $R_L = 5.1\text{ k}\Omega$, a 100 mV input step voltage that has a 5 mV overdrive

- With V_{IN} not applied, set the switch SW to the off position and adjust V_R so that V_O is in the vicinity of 1.4 V.
- Apply V_{IN} and turn the switch SW on.

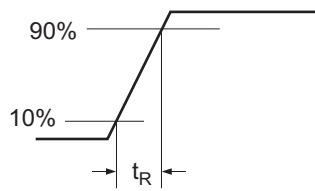

Characteristic Curves

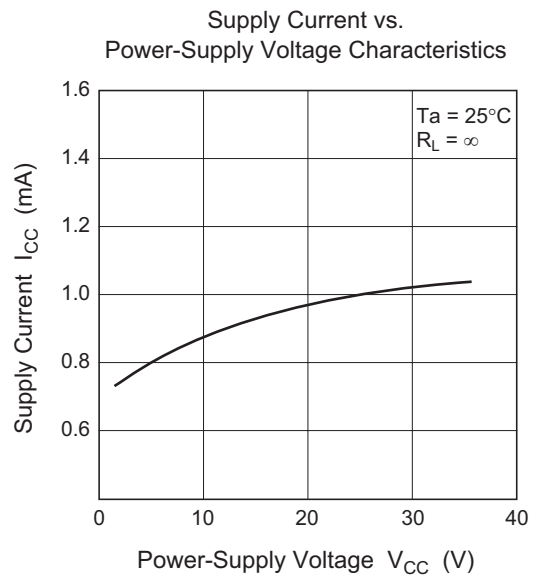
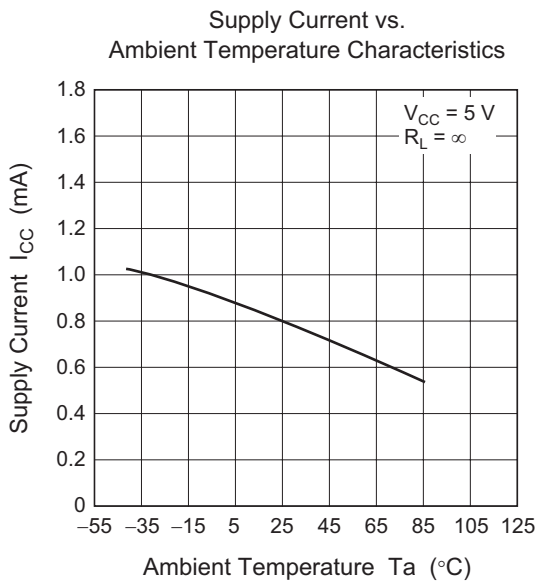
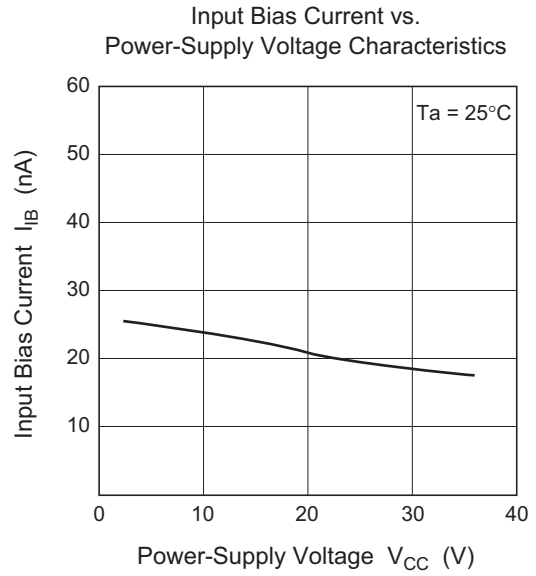
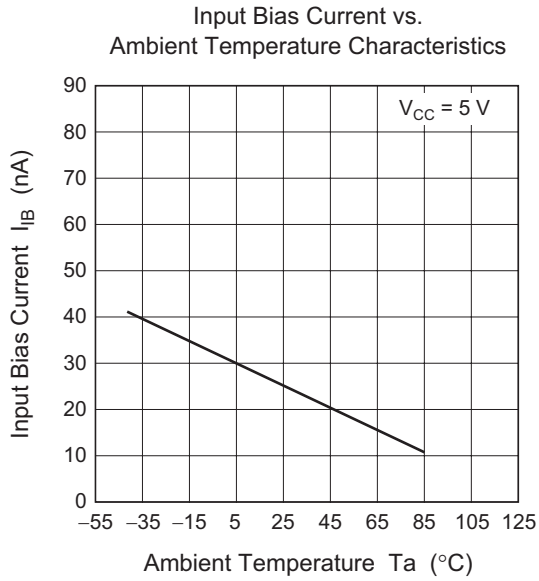

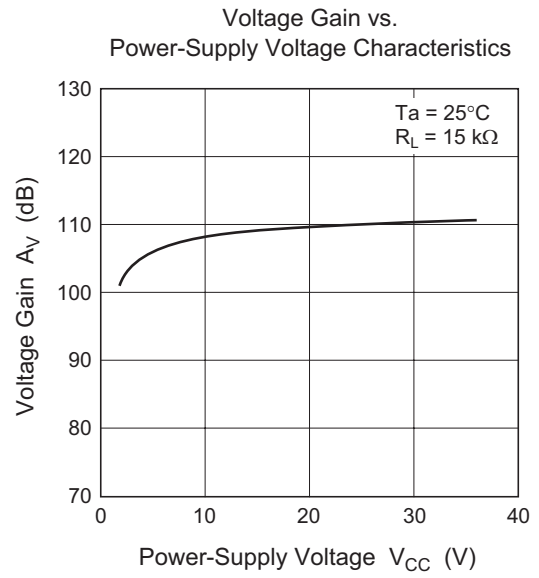
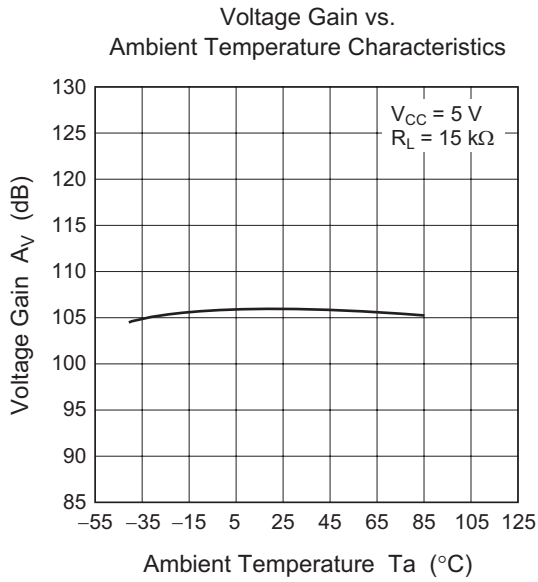
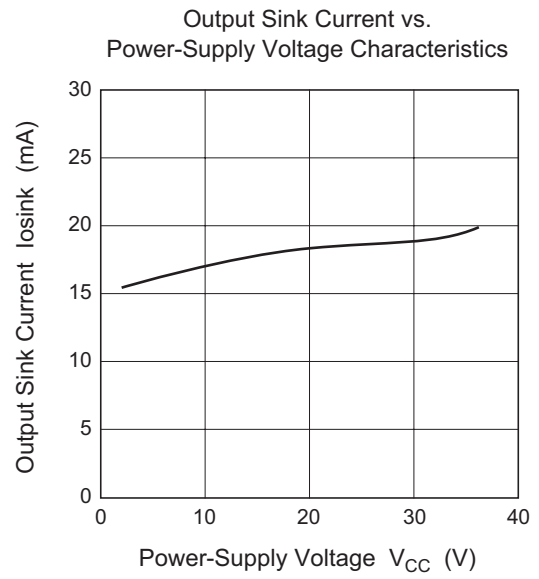
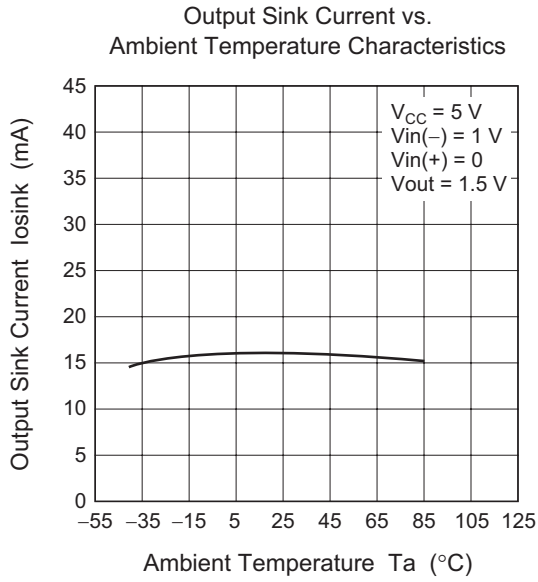

HA17901A Application Examples

The HA17901A houses four independent comparators in a single package, and operates over a wide voltage range at low power from a single-voltage power supply. Since the common-mode input voltage range starts at the ground potential, the HA17901A is particularly suited for single-voltage power supply applications. This section presents several sample HA17901A applications.

1. Square-Wave Oscillator

The circuit shown in figure 1 has the same structure as a single-voltage power supply astable multivibrator. Figure 2 shows the waveforms generated by this circuit.

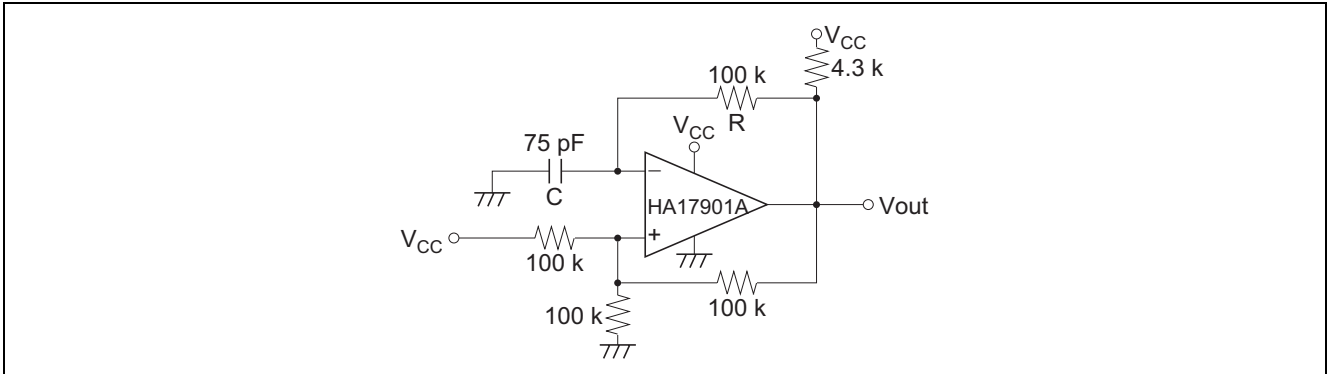

Figure 1 Square-Wave Oscillator

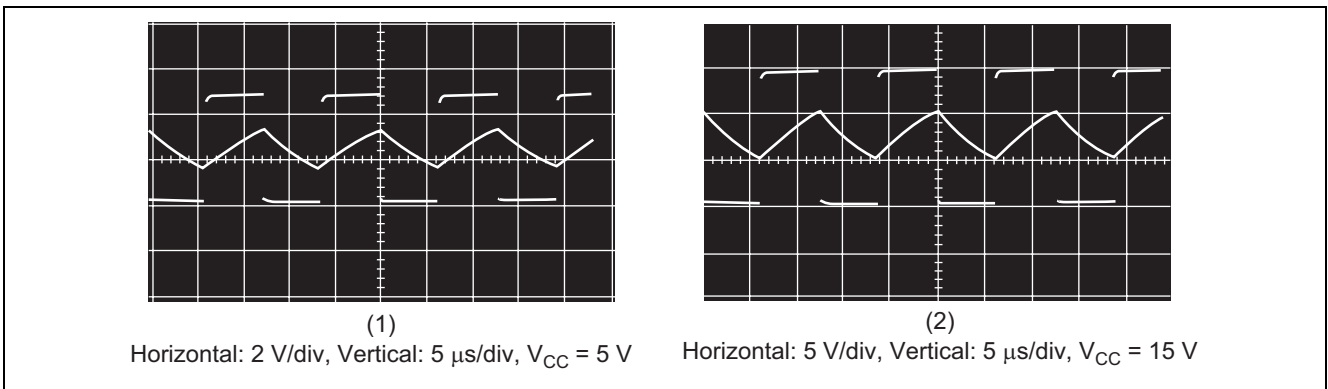

Figure 2 Operating Waveforms

2. Pulse Generator

The charge and discharge circuits in the circuit from figure 1 are separated by diodes in this circuit. (See figure 3.) This allows the pulse width and the duty cycle to be set independently. Figure 4 shows the waveforms generated by this circuit.

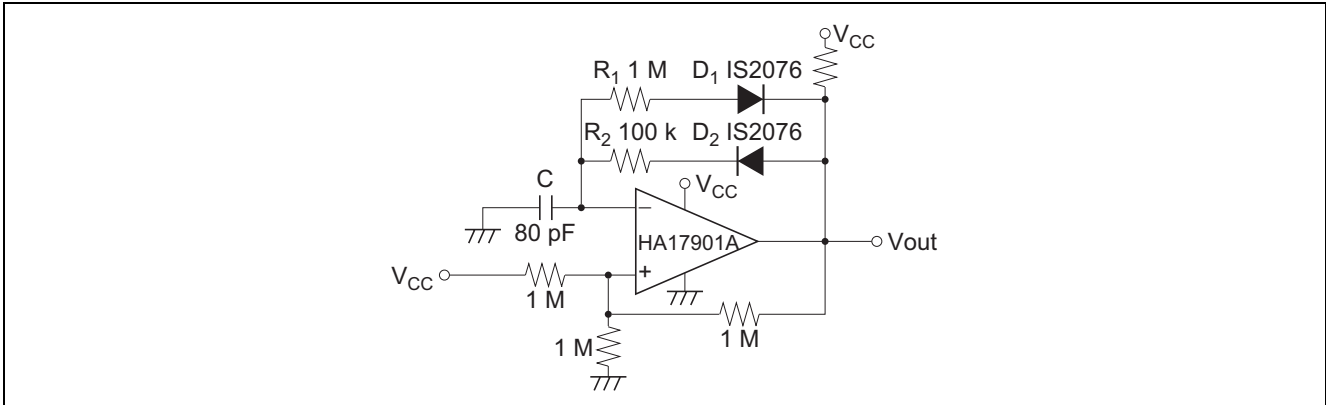

Figure 3 Pulse Generator

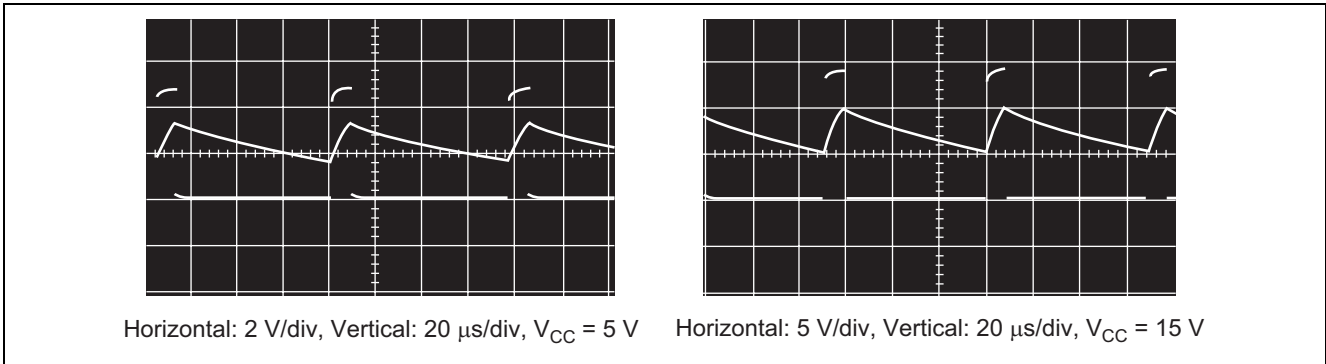

Figure 4 Operating Waveforms

3. Voltage Controlled Oscillator

In the circuit in figure 5, comparator A₁ operates as an integrator, A₂ operates as a comparator with hysteresis, and A₃ operates as the switch that controls the oscillator frequency. If the output Vout1 is at the low level, the A₃ output will go to the low level and the A₁ inverting input will become a lower level than the A₁ noninverting input. The A₁ output will integrate this state and its output will increase towards the high level. When the output of the integrator A₁ exceeds the level on the comparator A₂ inverting input, A₂ inverts to the high level and both the output Vout1 and the A₃ output go to the high level. This causes the integrator to integrate a negative state, resulting in its output decreasing towards the low level. Then, when the A₁ output level becomes lower than the level on the A₂ noninverting input, the output Vout1 is once again inverted to the low level. This operation generates a square wave on Vout1 and a triangular wave on Vout2.

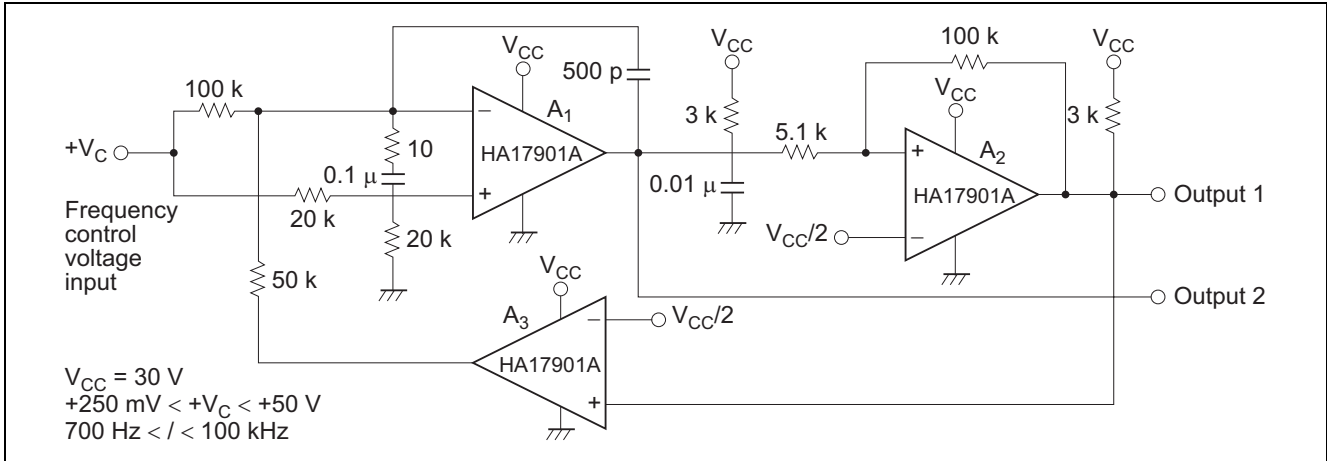

Figure 5 Voltage Controlled Oscillator

4. Basic Comparator

The circuit shown in figure 6 is a basic comparator. When the input voltage V_{IN} exceeds the reference voltage V_{REF}, the output goes to the high level.

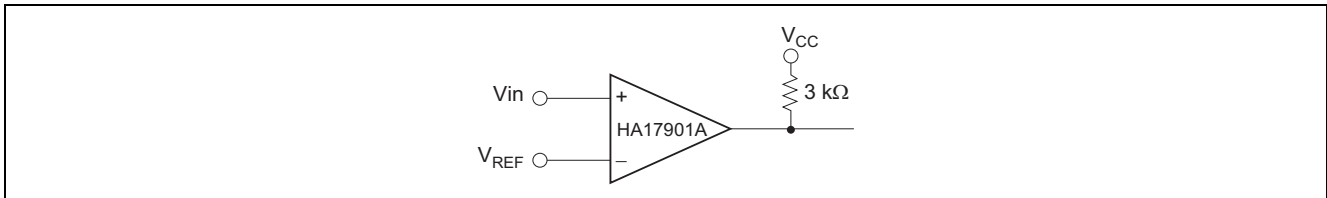

Figure 6 Basic Comparator

5. Noninverting Comparator (with Hysteresis)

Assuming $+V_{IN}$ is 0 V, when V_{REF} is applied to the inverting input, the output will go to the low level (approximately 0 V). If the voltage applied to $+V_{IN}$ is gradually increased, the output will go high when the value of the noninverting input, $+V_{IN} \times R_2 / (R_1 + R_2)$, exceeds $+V_{REF}$. Next, if $+V_{IN}$ is gradually lowered, V_{out} will be inverted to the low level once again when the value of the noninverting input, $(V_{out} - V_{IN}) \times R_1 / (R_1 + R_2)$, becomes lower than V_{REF} . With the circuit constants shown in figure 7, assuming $V_{CC} = 15$ V and $+V_{REF} = 6$ V, the following formula can be derived, i.e. $+V_{IN} \times 10 \text{ M} / (5.1 \text{ M} + 10 \text{ M}) > 6$ V, and V_{out} will invert from low to high when $+V_{IN}$ is > 9.06 V.

$$(V_{out} - V_{IN}) \times \frac{R_1}{R_1 + R_2} + V_{IN} < 6V$$

(Assuming $V_{out} = 15V$)

When $+V_{IN}$ is lowered, the output will invert from high to low when $+V_{IN} < 1.41$ V. Therefore this circuit has a hysteresis of 7.65 V. Figure 8 shows the input characteristics.

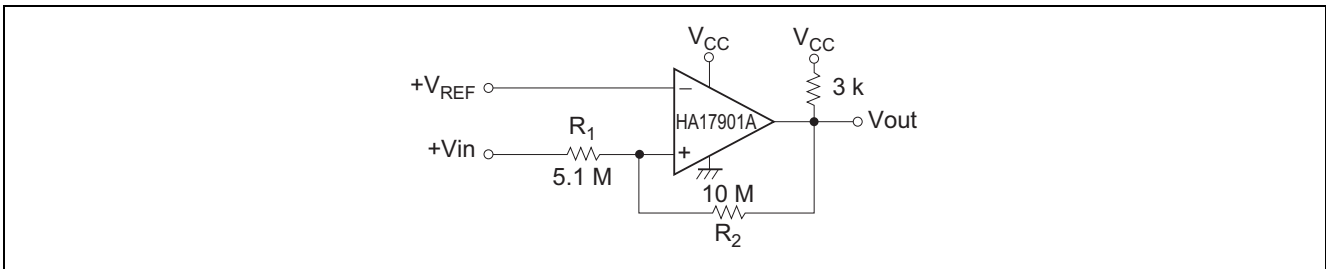

Figure 7 Noninverting Comparator

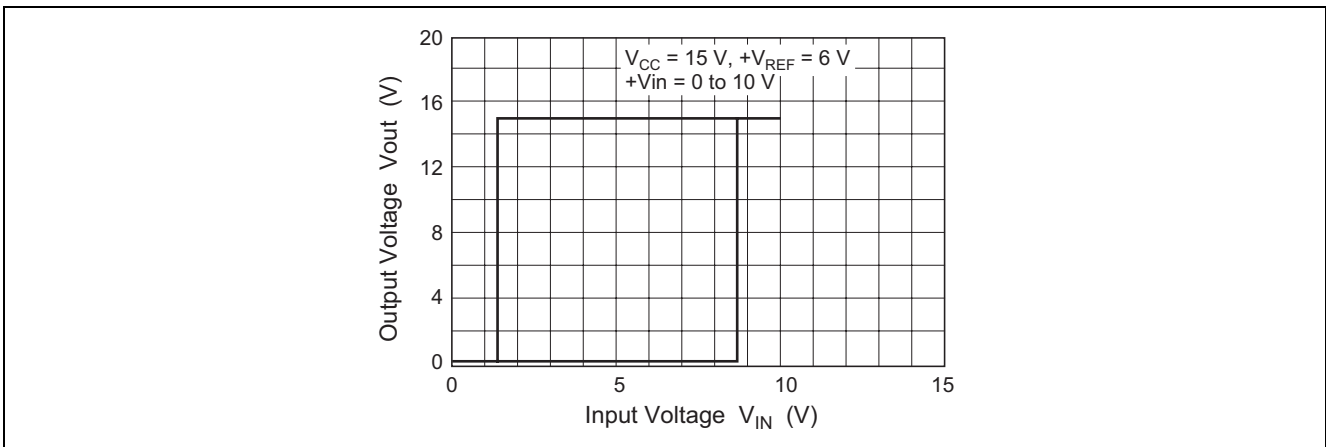

Figure 8 Noninverting Comparator I/O Transfer Characteristics

6. Inverting Comparator (with Hysteresis)

In this circuit, the output V_{out} inverts from high to low when $+V_{IN} > (V_{CC} + V_{out})/3$. Similarly, the output V_{out} inverts from low to high when $+V_{IN} < V_{CC}/3$. With the circuit constants shown in figure 9, assuming $V_{CC} = 15\text{ V}$ and $V_{out} = 15\text{ V}$, this circuit will have a 5 V hysteresis. Figure 10 shows the I/O characteristics for the circuit in figure 9.

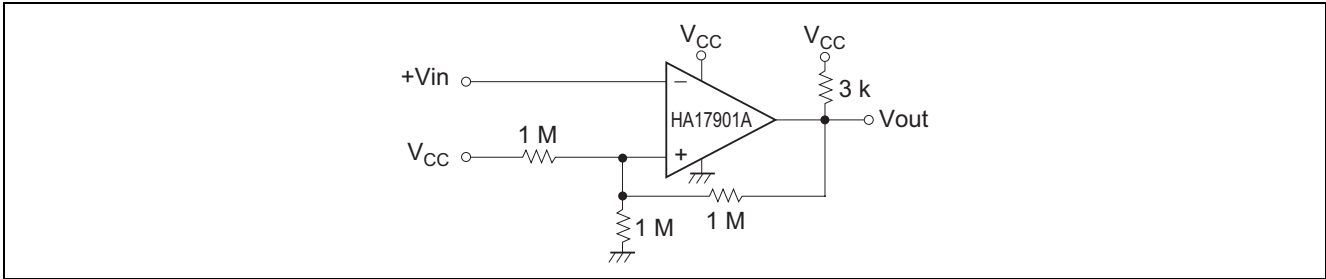

Figure 9 Inverting Comparator

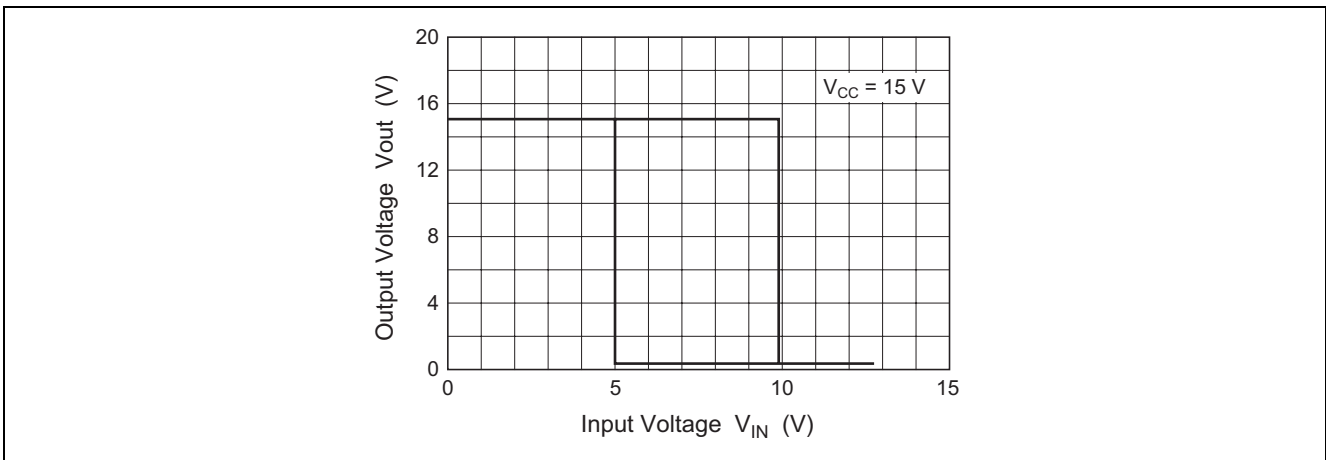

Figure 10 Inverting Comparator I/O Transfer Characteristics

7. Zero-Cross Detector (Single-Voltage Power Supply)

In this circuit, the noninverting input will essentially be held at the potential determined by dividing V_{CC} with 100 kΩ and 10 kΩ resistors. When V_{IN} is 0 V or higher, the output will be low, and when V_{IN} is negative, V_{out} will invert to the high level. (See figure 11.)

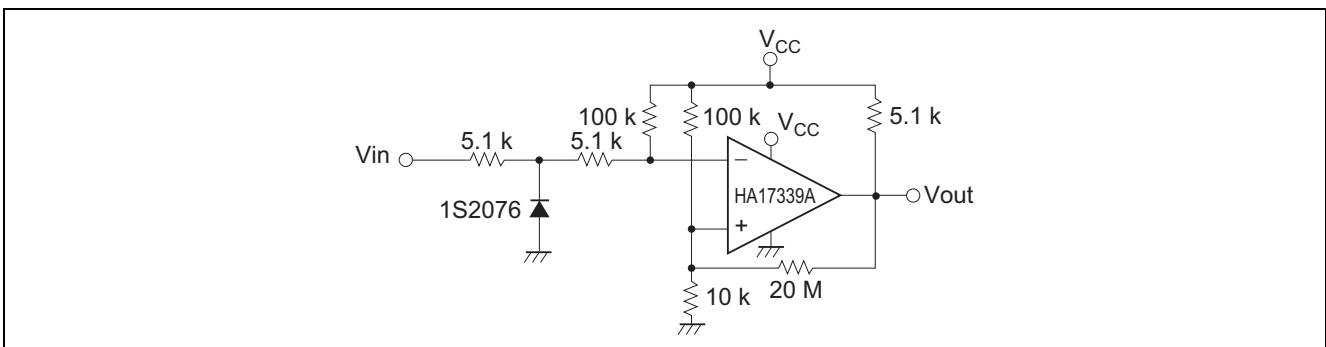
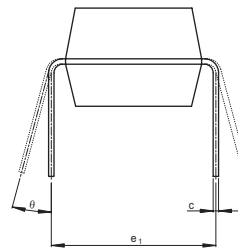
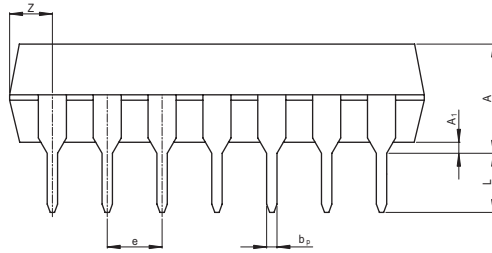
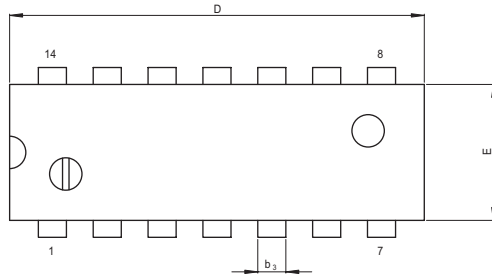

Figure 11 Zero-Cross Detector

Package Dimensions

JEITA Package Code	RENESAS Code	Previous Code	MASS[Typ.]
P-DIP14-6.3x19.2-2.54	PRDP0014AB-B	DP-14AV	0.97g



(Ni/Pd/Au plating)

Reference Symbol	Dimension in Millimeters		
	Min	Nom	Max
e ₁	—	7.62	—
D	—	19.2	20.32
E	—	6.3	7.4
A	—	—	5.06
A ₁	0.51	—	—
b _p	0.40	0.48	0.56
b ₃	—	1.30	—
c	0.19	0.25	0.31
θ	0°	—	15°
e	2.29	2.54	2.79
Z	—	—	2.39
L	2.54	—	—

JEITA Package Code	RENESAS Code	Previous Code	MASS[Typ.]
P-SOP14-5.5x10.06-1.27	PRSP0014DF-B	FP-14DAV	0.23g

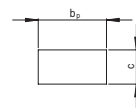
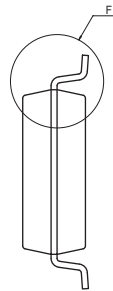
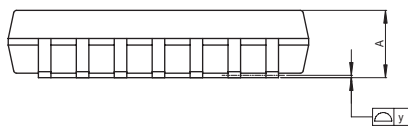
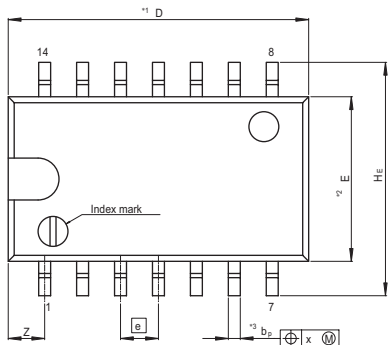

Terminal cross section (Ni/Pd/Au plating)

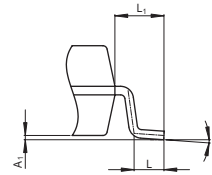

Detail F

NOTE)
 1. DIMENSIONS**1 (Nom)**AND**2* DO NOT INCLUDE MOLD FLASH.
 2. DIMENSION**3* DOES NOT INCLUDE TRIM OFFSET.

Reference Symbol	Dimension in Millimeters		
	Min	Nom	Max
D	—	10.06	10.5
E	—	5.50	—
A ₂	—	—	—
A ₁	0.00	0.10	0.20
A	—	—	2.20
b _p	0.34	0.40	0.46
b ₁	—	—	—
c	0.15	0.20	0.25
c ₁	—	—	—
θ	0°	—	8°
H _E	7.50	7.80	8.00
Ⓜ	—	1.27	—
x	—	—	0.12
y	—	—	0.15
Z	—	—	1.42
L	0.50	0.70	0.90
L ₁	—	1.15	—

HA17901A Series

JEITA Package Code	RENESAS Code	Previous Code	MASS[Typ.]
P-SOP14-3.95x8.65-1.27	PRSP0014DE-A	FP-14DNV	0.13g

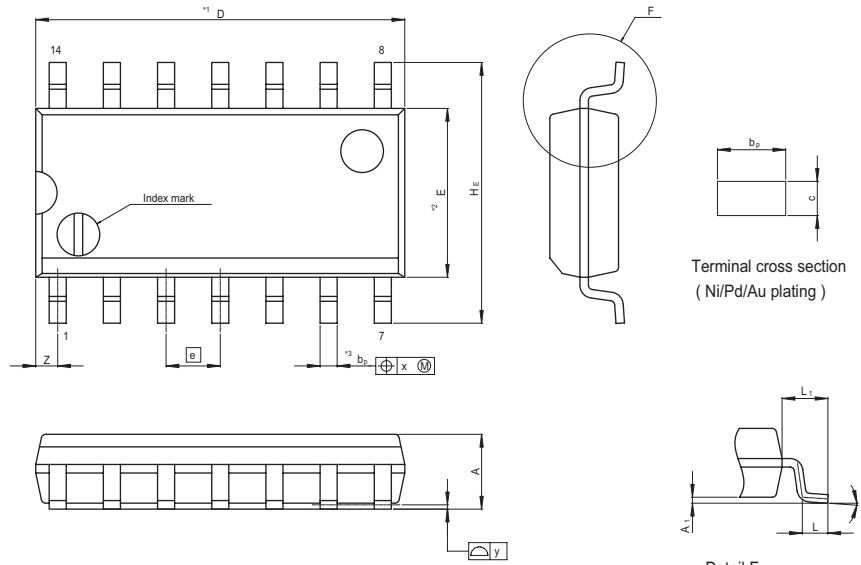

NOTE)
 1. DIMENSIONS**1 (Nom)**AND**2*
 DO NOT INCLUDE MOLD FLASH.
 2. DIMENSION**3*DOES NOT
 INCLUDE TRIM OFFSET.

Reference Symbol	Dimension in Millimeters		
	Min	Nom	Max
D	—	8.65	9.05
E	—	3.95	—
A ₂	—	—	—
A ₁	0.10	0.14	0.25
A	—	—	1.75
b _p	0.34	0.40	0.46
b ₁	—	—	—
c	0.15	0.20	0.25
c ₁	—	—	—
θ	0°	—	8°
H _E	5.80	6.10	6.20
Ⓜ	—	1.27	—
x	—	—	0.25
y	—	—	0.15
Z	—	—	0.635
L	0.40	0.60	1.27
L ₁	—	1.08	—

JEITA Package Code	RENESAS Code	Previous Code	MASS[Typ.]
P-TSSOP14-4.4x5-0.65	PTSP0014JA-B	TTP-14DV	0.05g

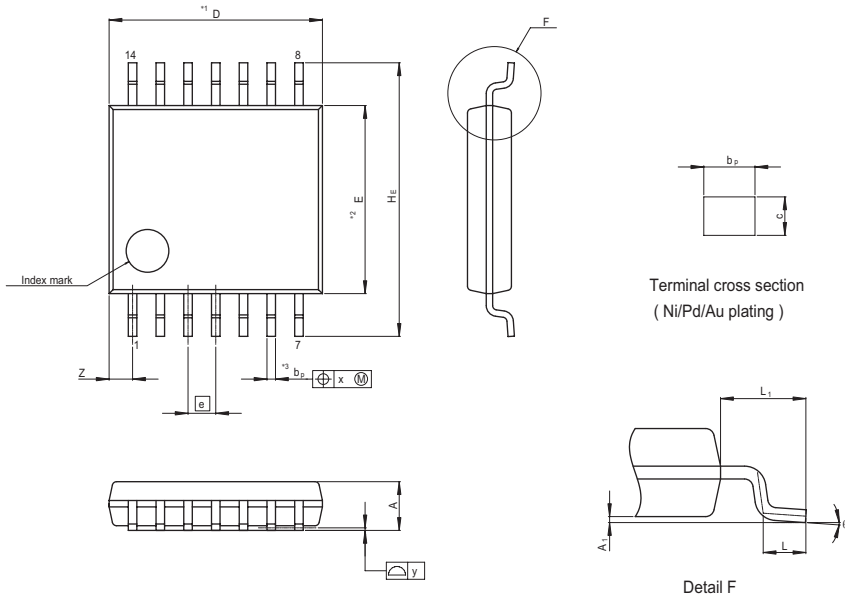

NOTE)
 1. DIMENSIONS**1 (Nom)**AND**2*
 DO NOT INCLUDE MOLD FLASH.
 2. DIMENSION**3*DOES NOT
 INCLUDE TRIM OFFSET.

Reference Symbol	Dimension in Millimeters		
	Min	Nom	Max
D	—	5.00	5.30
E	—	4.40	—
A ₂	—	—	—
A ₁	0.03	0.07	0.10
A	—	—	1.10
b _p	0.15	0.20	0.25
b ₁	—	—	—
c	0.10	0.15	0.20
c ₁	—	—	—
θ	0°	—	8°
H _E	6.20	6.40	6.60
Ⓜ	—	0.65	—
x	—	—	0.13
y	—	—	0.10
Z	—	—	0.83
L	0.4	0.5	0.6
L ₁	—	1.0	—

Keep safety first in your circuit designs!

1. Renesas Technology Corp. puts the maximum effort into making semiconductor products better and more reliable, but there is always the possibility that trouble may occur with them. Trouble with semiconductors may lead to personal injury, fire or property damage. Remember to give due consideration to safety when making your circuit designs, with appropriate measures such as (i) placement of substitutive, auxiliary circuits, (ii) use of nonflammable material or (iii) prevention against any malfunction or mishap.

Notes regarding these materials

1. These materials are intended as a reference to assist our customers in the selection of the Renesas Technology Corp. product best suited to the customer's application; they do not convey any license under any intellectual property rights, or any other rights, belonging to Renesas Technology Corp. or a third party.
 2. Renesas Technology Corp. assumes no responsibility for any damage, or infringement of any third-party's rights, originating in the use of any product data, diagrams, charts, programs, algorithms, or circuit application examples contained in these materials.
 3. All information contained in these materials, including product data, diagrams, charts, programs and algorithms represents information on products at the time of publication of these materials, and are subject to change by Renesas Technology Corp. without notice due to product improvements or other reasons. It is therefore recommended that customers contact Renesas Technology Corp. or an authorized Renesas Technology Corp. product distributor for the latest product information before purchasing a product listed herein.
The information described here may contain technical inaccuracies or typographical errors.
Renesas Technology Corp. assumes no responsibility for any damage, liability, or other loss rising from these inaccuracies or errors.
Please also pay attention to information published by Renesas Technology Corp. by various means, including the Renesas Technology Corp. Semiconductor home page (<http://www.renesas.com>).
 4. When using any or all of the information contained in these materials, including product data, diagrams, charts, programs, and algorithms, please be sure to evaluate all information as a total system before making a final decision on the applicability of the information and products. Renesas Technology Corp. assumes no responsibility for any damage, liability or other loss resulting from the information contained herein.
 5. Renesas Technology Corp. semiconductors are not designed or manufactured for use in a device or system that is used under circumstances in which human life is potentially at stake. Please contact Renesas Technology Corp. or an authorized Renesas Technology Corp. product distributor when considering the use of a product contained herein for any specific purposes, such as apparatus or systems for transportation, vehicular, medical, aerospace, nuclear, or undersea repeater use.
 6. The prior written approval of Renesas Technology Corp. is necessary to reprint or reproduce in whole or in part these materials.
 7. If these products or technologies are subject to the Japanese export control restrictions, they must be exported under a license from the Japanese government and cannot be imported into a country other than the approved destination.
Any diversion or reexport contrary to the export control laws and regulations of Japan and/or the country of destination is prohibited.
 8. Please contact Renesas Technology Corp. for further details on these materials or the products contained therein.
-



RENESAS SALES OFFICES

<http://www.renesas.com>

Refer to "<http://www.renesas.com/en/network>" for the latest and detailed information.

Renesas Technology America, Inc.

450 Holger Way, San Jose, CA 95134-1368, U.S.A
Tel: <1> (408) 382-7500, Fax: <1> (408) 382-7501

Renesas Technology Europe Limited

Dukes Meadow, Millboard Road, Bourne End, Buckinghamshire, SL8 5FH, U.K.
Tel: <44> (1628) 585-100, Fax: <44> (1628) 585-900

Renesas Technology (Shanghai) Co., Ltd.

Unit 204, 205, AZIACenter, No.1233 Lujiazui Ring Rd, Pudong District, Shanghai, China 200120
Tel: <86> (21) 5877-1818, Fax: <86> (21) 6887-7898

Renesas Technology Hong Kong Ltd.

7th Floor, North Tower, World Finance Centre, Harbour City, 1 Canton Road, Tsimshatsui, Kowloon, Hong Kong
Tel: <852> 2265-6688, Fax: <852> 2730-6071

Renesas Technology Taiwan Co., Ltd.

10th Floor, No.99, Fushing North Road, Taipei, Taiwan
Tel: <886> (2) 2715-2888, Fax: <886> (2) 2713-2999

Renesas Technology Singapore Pte. Ltd.

1 Harbour Front Avenue, #06-10, Keppel Bay Tower, Singapore 098632
Tel: <65> 6213-0200, Fax: <65> 6278-8001

Renesas Technology Korea Co., Ltd.

Kukje Center Bldg. 18th Fl., 191, 2-ka, Hangang-ro, Yongsan-ku, Seoul 140-702, Korea
Tel: <82> (2) 796-3115, Fax: <82> (2) 796-2145

Renesas Technology Malaysia Sdn. Bhd

Unit 906, Block B, Menara Amcorp, Amcorp Trade Centre, No.18, Jalan Persiaran Barat, 46050 Petaling Jaya, Selangor Darul Ehsan, Malaysia
Tel: <603> 7955-9390, Fax: <603> 7955-9510