

ISL91127IR

High Efficiency Buck-Boost Regulator with 4.5A Switches

FN8859  
Rev 1.01  
Aug 26, 2022

The [ISL91127IR](#) is a high-current buck-boost switching regulator for systems using new battery chemistries. It uses Renesas' proprietary buck-boost algorithm to maintain voltage regulation while providing excellent efficiency and very low output voltage ripple when the input voltage is close to the output voltage.

The ISL91127IR is capable of delivering at least 2A continuous output current ( $V_{OUT} = 3.3V$ ) over a battery voltage range of 2.5V to 4.35V. This maximizes the energy utilization of advanced single-cell Li-ion battery chemistries that have significant capacity left at voltages below the system voltage. Its fully synchronous low ON-resistance, 4-switch architecture and a low quiescent current of only 30 $\mu$ A optimize efficiency under all load conditions.

The ISL91127IR supports stand-alone applications with a fixed 3.3V or 3.5V output voltage or adjustable output voltage with an external resistor divider. Output voltages as low as 1.0V or as high as 5.2V are supported.

The ISL91127IR is available in a 20 Ld, 0.5mm pitch QFN (4mmx4mm) package. The 2.5MHz switching frequency further reduces the size of external components.

Features

- Accepts input voltages above or below regulated output voltage
- Automatic and seamless transitions between buck and boost modes
- Input voltage range: 1.8V to 5.5V
- Output current: up to 2A ( $P_{VIN} = 2.5V, V_{OUT} = 3.3V$ )
- High efficiency: up to 96%
- 30 $\mu$ A quiescent current maximizes light-load efficiency
- 2.5MHz switching frequency minimizes external component size
- Fully protected for short-circuit, over-temperature and undervoltage
- 20 Ld 4mmx4mm QFN package

Applications

- Handheld and battery powered consumer and medical devices
- Brownout free system voltage for smartphones and tablet PCs
- Wireless communication devices
- 2G/3G/4G RF power amplifiers

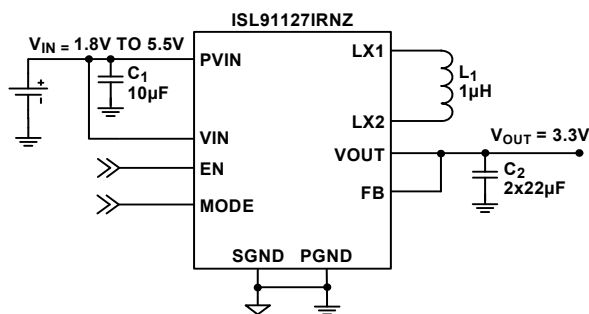

FIGURE 1. TYPICAL APPLICATION:  $V_{OUT} = 3.3V$

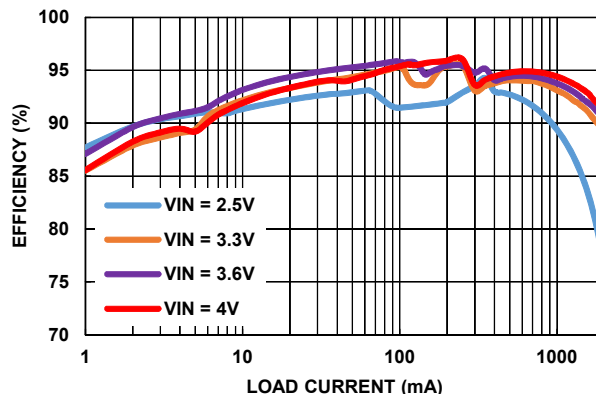

FIGURE 2. EFFICIENCY:  $V_{OUT} = 3.3V, T_A = +25^\circ C$

# Block Diagram

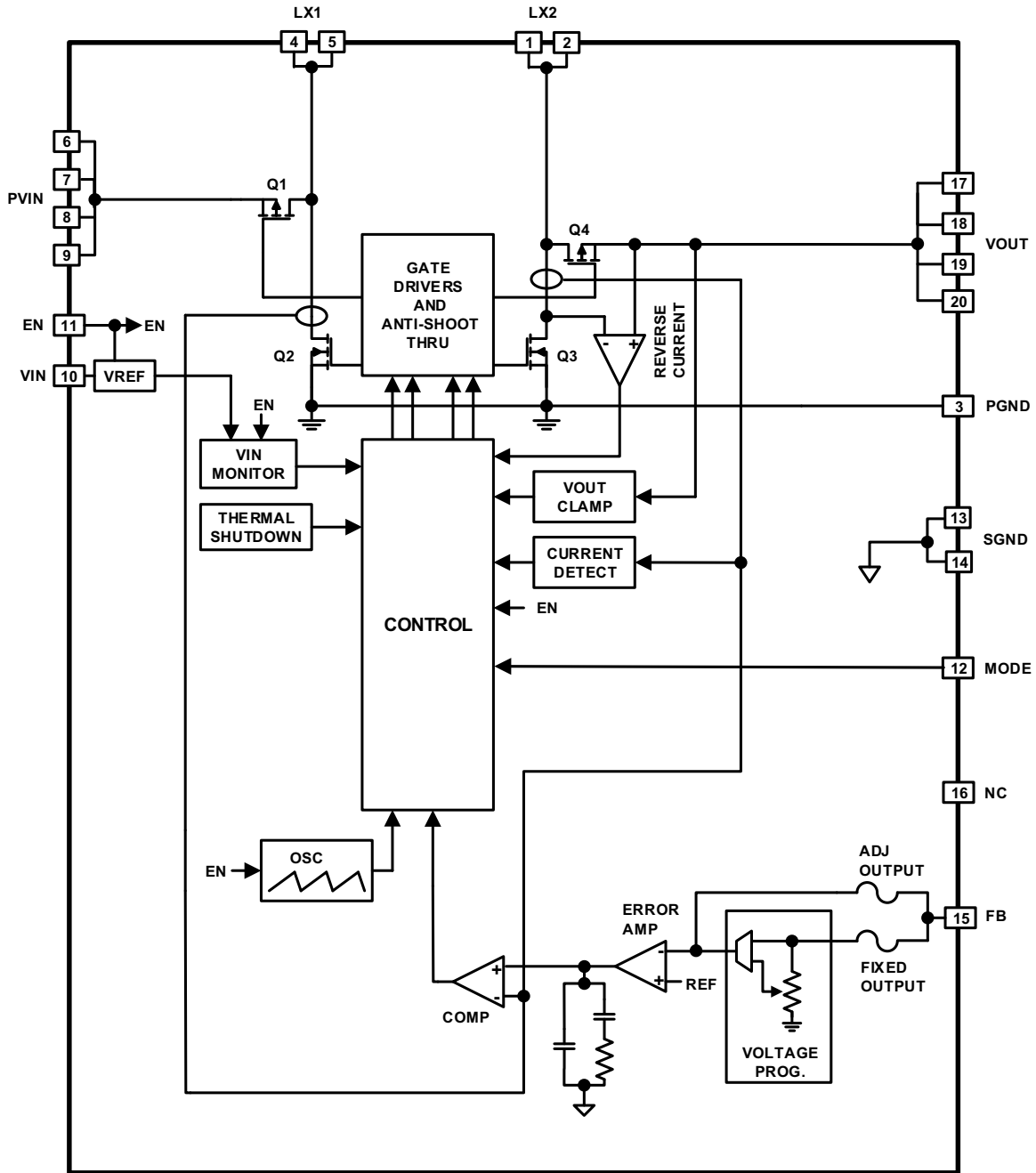
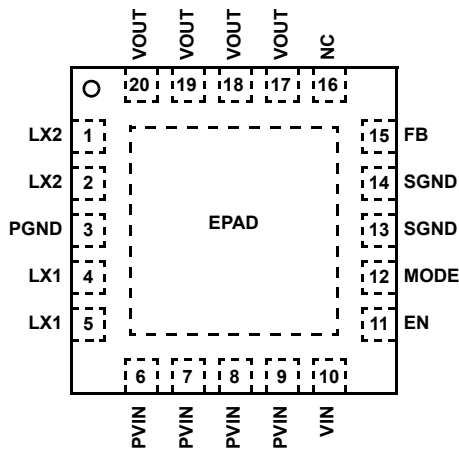

FIGURE 3. BLOCK DIAGRAM

## Pin Configuration

ISL91127IR  
(20 LD, 4x4 QFN)  
TOP VIEW



## Pin Descriptions

PIN #	PIN NAMES	DESCRIPTION
6, 7, 8, 9	PVIN	Power input. Range: 1.8V to 5.5V. Connect 2x10 $\mu$ F capacitors to PGND.
4, 5	LX1	Inductor connection, input side
3	PGND	Power ground for high switching current
1, 2	LX2	Inductor connection, output side
17, 18, 19, 20	VOUT	Buck-boost regulator output. Connect 2x22 $\mu$ F capacitors to PGND.
12	MODE	Logic input, HIGH for auto PFM mode. LOW for forced PWM operation. Also, this pin can be used with an external clock sync input. Range: 2.75MHz to 3.25MHz.
10	VIN	Supply input. Range: 1.8V to 5.5V.
11	EN	Logic input, drive HIGH to enable device.
13, 14	SGND	Analog ground pin
15	FB	Voltage feedback pin
16	NC	No connect pin
	EPAD	Thermal pad, connect to PGND

## Ordering Information

PART NUMBER (Notes 2, 3)	PART MARKING	OUTPUT VOLTAGE (V)	PACKAGE (RoHS COMPLIANT)	PKG. DWG. #	CARRIER TYPE (Note 1)	TEMP. RANGE
ISL91127IRNZ-T	1127N	3.3	20 Ld 4x4 QFN	L20.4x4C	Reel, 6k	-40 to +85°C
ISL91127IRNZ-T7A					Reel, 250	
ISL91127IRAZ-T	1127A	ADJ			Reel, 6k	
ISL91127IRAZ-T7A					Reel, 250	
ISL91127IRN-EVZ	Evaluation Board for ISL91127IRNZ					
ISL91127IRA-EVZ	Evaluation Board for ISL91127IRAZ					

### NOTES:

- Please refer to [TB347](#) for details on reel specifications.
- These Pb-free plastic packaged products employ special Pb-free material sets, molding compounds/die attach materials, and 100% matte tin plate plus anneal (e3 termination finish, which is RoHS compliant and compatible with both SnPb and Pb-free soldering operations). Pb-free products are MSL classified at Pb-free peak reflow temperatures that meet or exceed the Pb-free requirements of IPC/JEDEC J STD-020.
- For Moisture Sensitivity Level (MSL), please see product information page for [ISL91127IR](#). For more information on MSL please see techbrief [TB363](#).

TABLE 1. KEY DIFFERENCES BETWEEN FAMILY OF PARTS

PART NUMBER	BUCK-BOOST REGULATION	BYPASS	VSEL	I <sup>2</sup> C AND DVS	PACKAGE
ISL91127	Yes	No	No	No	WLCSP
ISL91127IR	Yes	No	No	No	QFN
ISL91128	Yes	Yes	No	Yes	WLCSP

NOTE: For the full family of ISL911xx buck-boost regulators, see the Buck-boost Regulator [website](#).

## Absolute Maximum Ratings

PVIN, VIN	-0.3V to 6.5V
LX1, LX2	-0.3V to 6.5V
FB (Adjustable Version)	-0.3V to 2.7V
FB (Fixed V <sub>OUT</sub> Versions)	-0.3V to 6.5V
GND, PGND	-0.3V to 0.3V
All Other Pins	-0.3V to 6.5V
ESD Rating	
Human Body Model (Tested per JS-001-2010)	2.5kV
Machine Model (Tested per JESD22-A115C)	250V
Charged Device Model (Tested per JS-002-2014)	1kV
Latch-Up (Tested per JESD-78B; Class 2, Level A)	100mA

## Thermal Information

Thermal Resistance (Typical)	$\theta_{JA}$ (°C/W)	$\theta_{JC}$ (°C/W)
20 Ld 4x4 QFN Package (Notes 4, 5)	40	5
Maximum Junction Temperature	+125°C	
Storage Temperature Range	-65°C to +150°C	
Pb-Free Reflow Profile	see <a href="#">TB493</a>	

## Recommended Operating Conditions

Ambient Temperature Range	-40°C to +85°C
Supply Voltage Range	1.8V to 5.5V
Maximum Load Current	
V <sub>IN</sub> = 2.5V V <sub>OUT</sub> = 3.3V	2ADC

CAUTION: Do not operate at or near the maximum ratings listed for extended periods of time. Exposure to such conditions can adversely impact product reliability and result in failures not covered by warranty.

### NOTES:

- $\theta_{JA}$  is measured in free air with the component mounted on a high effective thermal conductivity test board with "direct attach" features. See [TB379](#)
- For  $\theta_{JC}$ , the "case temp" location is the center of the exposed metal pad on the package underside.

**Analog Specifications** V<sub>IN</sub> = V<sub>PVIN</sub> = V<sub>EN</sub> = 3.6V, V<sub>OUT</sub> = 3.3V, L<sub>1</sub> = 1μH, C<sub>1</sub> = 10μF, C<sub>2</sub> = 2x22μF, T<sub>A</sub> = +25°C. **Boldface limits apply across the operating temperature range, -40°C to +85°C and input voltage range (1.8V to 5.5V) unless specified otherwise.**

SYMBOL	PARAMETER	TEST CONDITIONS	MIN (Note 6)	TYP (Note 7)	MAX (Note 6)	UNIT
<b>POWER SUPPLY</b>						
V <sub>IN</sub>	Input Voltage Range		<b>1.8</b>		<b>5.5</b>	V
V <sub>UVLO</sub>	V <sub>IN</sub> Undervoltage Lockout Threshold	Rising		1.725	<b>1.795</b>	V
		Falling	<b>1.55</b>	1.65		V
I <sub>VIN</sub>	V <sub>IN</sub> Supply Current	PFM mode, 1.8V ≤ V <sub>IN</sub> ≤ 5V, no external load on V <sub>OUT</sub> (Note 8)		30	<b>55</b>	μA
I <sub>SD</sub>	V <sub>IN</sub> Supply Current, Shutdown	EN = GND, V <sub>IN</sub> = 3.6V		0.05	<b>1.00</b>	μA
<b>OUTPUT VOLTAGE REGULATION</b>						
V <sub>OUT</sub>	Output Voltage Range	ISL91127IIAZ, I <sub>OUT</sub> = 100mA, V <sub>IN</sub> = 3.6V	<b>1.0</b>		<b>5.2</b>	V
	Output Voltage Accuracy	V <sub>IN</sub> = 3.7V, V <sub>OUT</sub> = 3.3V, I <sub>OUT</sub> = 0mA, PWM mode	<b>-2</b>		<b>+2</b>	%
		V <sub>IN</sub> = 3.7V, V <sub>OUT</sub> = 3.3V, I <sub>OUT</sub> = 1mA, PFM mode	<b>-3</b>		<b>+4</b>	%
V <sub>FB</sub>	FB Pin Voltage Regulation	For adjustable output version, V <sub>IN</sub> = 3.6V	<b>0.783</b>	0.800	<b>0.813</b>	V
I <sub>FB</sub>	FB Pin Bias Current	For adjustable output version			<b>20</b>	nA
$\frac{\Delta V_{OUT}}{\Delta V_{IN}}$	Line Regulation, PWM Mode	I <sub>OUT</sub> = 500mA, V <sub>OUT</sub> = 3.3V, V <sub>IN</sub> step from 2.3V to 5.5V		±5		mV/V
$\frac{\Delta V_{OUT}}{\Delta I_{OUT}}$	Load Regulation, PWM Mode	V <sub>IN</sub> = 3.7V, V <sub>OUT</sub> = 3.3V, I <sub>OUT</sub> step from 0mA to 1000mA		±0.005		mV/mA
$\frac{\Delta V_{OUT}}{\Delta V_I}$	Line Regulation, PFM Mode	I <sub>OUT</sub> = 100mA, V <sub>OUT</sub> = 3.3V, V <sub>IN</sub> step from 2.3V to 5.5V		±12.5		mV/V
$\frac{\Delta V_{OUT}}{\Delta I_{OUT}}$	Load Regulation, PFM Mode	V <sub>IN</sub> = 3.7V, V <sub>OUT</sub> = 3.3V, I <sub>OUT</sub> step from 0mA to 100mA		±0.4		mV/mA
V <sub>CLAMP</sub>	Output Voltage Clamp	Rising	<b>5.25</b>		<b>5.95</b>	V
	Output Voltage Clamp Hysteresis			400		mV

**Analog Specifications**  $V_{IN} = V_{PVIN} = V_{EN} = 3.6V$ ,  $V_{OUT} = 3.3V$ ,  $L_1 = 1\mu H$ ,  $C_1 = 10\mu F$ ,  $C_2 = 2 \times 22\mu F$ ,  $T_A = +25^\circ C$ . **Boldface limits apply across the operating temperature range,  $-40^\circ C$  to  $+85^\circ C$  and input voltage range (1.8V to 5.5V) unless specified otherwise. (Continued)**

SYMBOL	PARAMETER	TEST CONDITIONS	MIN (Note 6)	TYP (Note 7)	MAX (Note 6)	UNIT
<b>DC/DC SWITCHING SPECIFICATIONS</b>						
$f_{SW}$	Oscillator Frequency		<b>2.1</b>	2.5	<b>2.9</b>	MHz
$t_{ONMIN}$	Minimum On-Time			80		ns
$I_{PFETLEAK}$	LX1 Pin Leakage Current	$V_{IN} = 3.6V$	<b>-1</b>		<b>1</b>	$\mu A$
$I_{NFETLEAK}$	LX2 Pin Leakage Current	$V_{IN} = 3.6V$	<b>-1</b>		<b>1</b>	$\mu A$
<b>SOFT-START AND SOFT DISCHARGE</b>						
$t_{SS}$	Soft-Start Time	Time from when EN signal asserts to when output voltage ramp starts.		1		ms
		Time from when output voltage ramp starts to when output voltage reaches 95% of its nominal value with device operating in buck mode. $V_{IN} = 4V$ , $V_{OUT} = 3.3V$ , $I_O = 200mA$		1		ms
		Time from when output voltage ramp starts to when output voltage reaches 95% of its nominal value with device operating in boost mode. $V_{IN} = 2V$ , $V_{OUT} = 3.3V$ , $I_O = 200mA$		2		ms
$r_{DISCHG}$	$V_{OUT}$ Soft-Discharge ON-Resistance	$EN < V_{IL}$		120		$\Omega$
<b>POWER MOSFET</b>						
$r_{DS0N\_P}$	P-Channel MOSFET ON-Resistance	$V_{IN} = 3.6V$ , $I_O = 200mA$		32		$m\Omega$
$r_{DS0N\_N}$	N-Channel MOSFET ON-Resistance	$V_{IN} = 3.6V$ , $I_O = 200mA$		37		$m\Omega$
$I_{PK\_LMT}$	P-Channel MOSFET Peak Current Limit	$V_{IN} = 3.6V$	<b>3.7</b>	4.5	<b>5</b>	A
<b>PFM/PWM TRANSITION</b>						
	Load Current Threshold, PFM to PWM	$V_{IN} = 3.6V$ , $V_{OUT} = 3.3V$		200		mA
	Load Current Threshold, PWM to PFM	$V_{IN} = 3.6V$ , $V_{OUT} = 3.3V$		75		mA
	Thermal Shutdown			155		$^\circ C$
	Thermal Shutdown Hysteresis			30		$^\circ C$
<b>LOGIC INPUTS</b>						
$I_{LEAK}$	Input Leakage	$V_{IN} = 3.6V$		0.05	<b>1</b>	$\mu A$
$V_{IH}$	Input HIGH Voltage	$V_{IN} = 3.6V$	<b>1.4</b>			V
$V_{IL}$	Input LOW Voltage	$V_{IN} = 3.6V$			<b>0.4</b>	V

## NOTES:

- Parameters with MIN and/or MAX limits are 100% tested at  $+25^\circ C$ , unless otherwise specified. Temperature limits established by characterization and are not production tested.
- Typical values are for  $T_A = +25^\circ C$  and  $V_{IN} = 3.6V$ .
- Quiescent current measurements are taken when the output is not switching.

# Typical Performance Curves

Unless otherwise noted, operating conditions are:  $T_A = +25^\circ\text{C}$ ,  $V_{IN} = EN = 3.6\text{V}$ ,  $L = 1\mu\text{H}$ ,  $C_1 = 10\mu\text{F}$ ,  $C_2 = 2 \times 22\mu\text{F}$ ,  $V_{OUT} = 3.3\text{V}$ ,  $I_{OUT} = 0\text{A to } 3\text{A}$

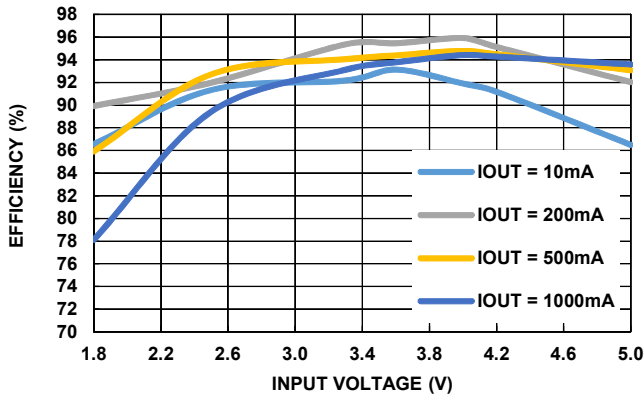

FIGURE 4. EFFICIENCY vs INPUT VOLTAGE

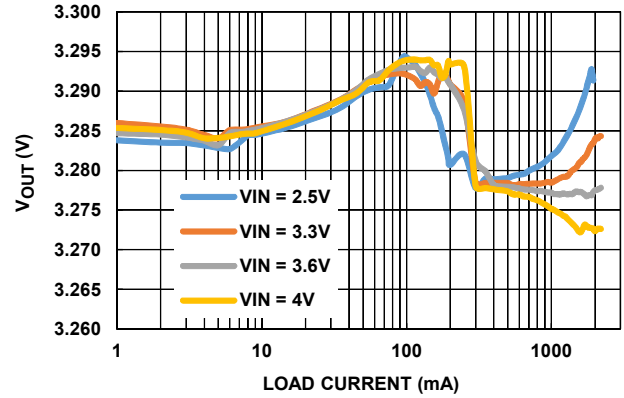

FIGURE 5. OUTPUT VOLTAGE vs LOAD CURRENT

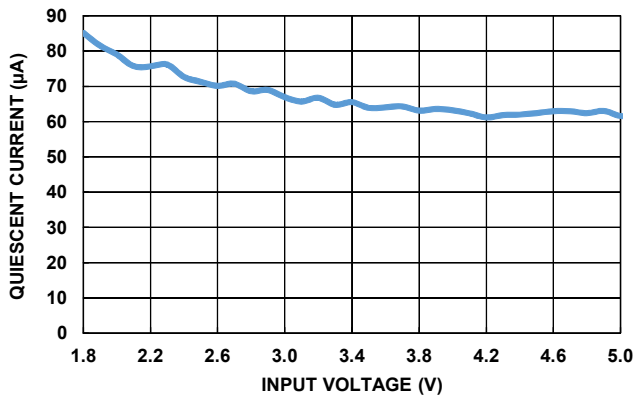

FIGURE 6. QUIESCENT CURRENT vs INPUT VOLTAGE ( $V_{OUT} = 3.3\text{V}$ , MODE = HIGH)

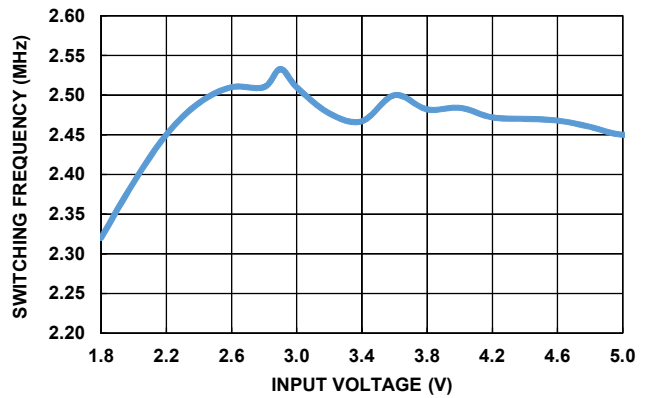

FIGURE 7. SWITCHING FREQUENCY vs INPUT VOLTAGE

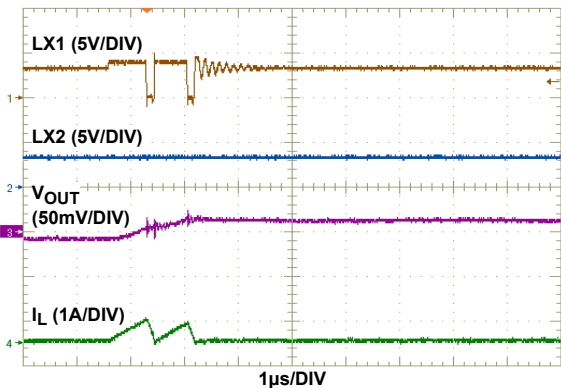

FIGURE 8. STEADY STATE OPERATION IN PFM ( $V_{IN} = 4\text{V}$ ,  $V_{OUT} = 3.3\text{V}$ , NO LOAD)

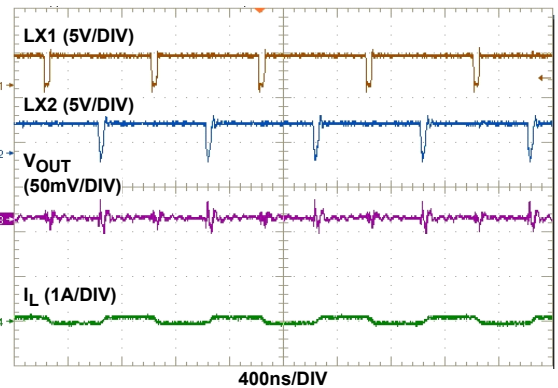

FIGURE 9. STEADY STATE OPERATION IN PWM ( $V_{IN} = 3.3\text{V}$ ,  $V_{OUT} = 3.3\text{V}$ , NO LOAD)

## Typical Performance Curves

Unless otherwise noted, operating conditions are:  $T_A = +25^\circ\text{C}$ ,  $V_{IN} = EN = 3.6\text{V}$ ,  $L = 1\mu\text{H}$ ,  $C_1 = 10\mu\text{F}$ ,  $C_2 = 2 \times 22\mu\text{F}$ ,  $V_{OUT} = 3.3\text{V}$ ,  $I_{OUT} = 0\text{A to } 3\text{A}$  (Continued)

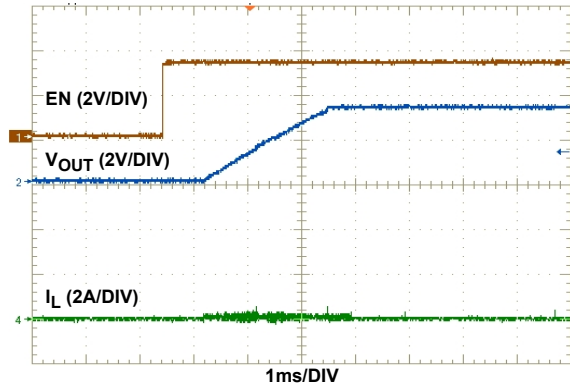

FIGURE 10. SOFT-START ( $V_{IN} = 3.6\text{V}$ ,  $V_{OUT} = 3.3\text{V}$ , NO LOAD)

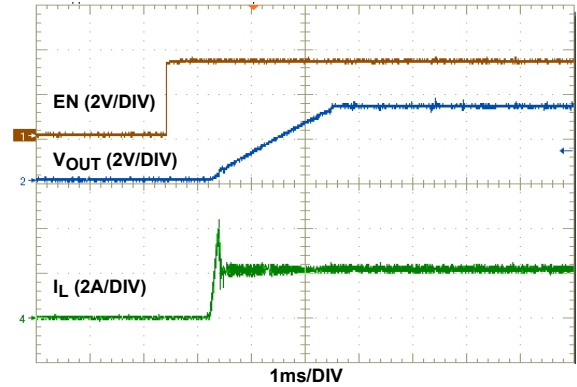

FIGURE 11. SOFT-START ( $V_{IN} = 3.6\text{V}$ ,  $V_{OUT} = 3.3\text{V}$ , 1A R-LOAD)

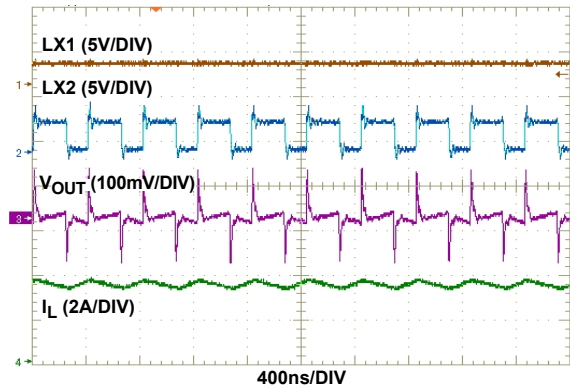

FIGURE 12. STEADY STATE OPERATION ( $V_{IN} = 2.5\text{V}$ ,  $V_{OUT} = 3.3\text{V}$ , 2A LOAD)

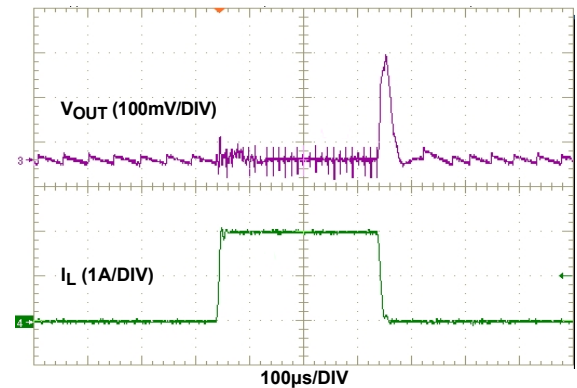

FIGURE 13. 0A TO 2A LOAD TRANSIENT ( $V_{IN} = 3.6\text{V}$ ,  $V_{OUT} = 3.3\text{V}$ )

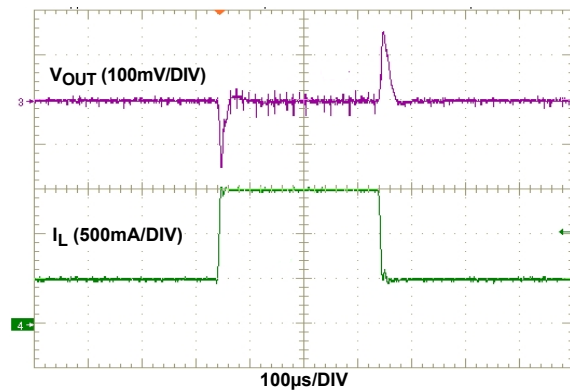

FIGURE 14. 0.5A TO 1.5A LOAD TRANSIENT ( $V_{IN} = 3.6\text{V}$ ,  $V_{OUT} = 3.3\text{V}$ )

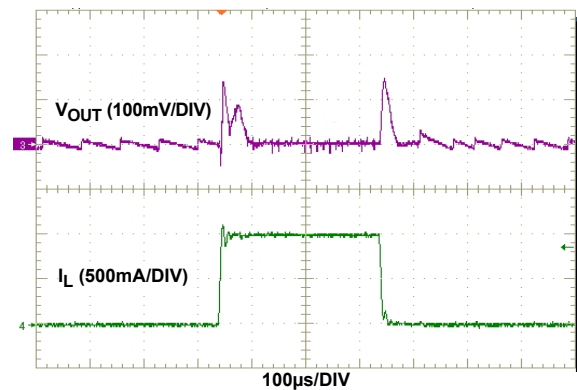

FIGURE 15. 0A TO 1A LOAD TRANSIENT ( $V_{IN} = 3.6\text{V}$ ,  $V_{OUT} = 3.3\text{V}$ )

## Typical Performance Curves

Unless otherwise noted, operating conditions are:  $T_A = +25^\circ\text{C}$ ,  $V_{IN} = V_{EN} = 3.6\text{V}$ ,  $L = 1\mu\text{H}$ ,  $C_1 = 10\mu\text{F}$ ,  $C_2 = 2 \times 22\mu\text{F}$ ,  $V_{OUT} = 3.3\text{V}$ ,  $I_{OUT} = 0\text{A}$  to  $3\text{A}$  (Continued)

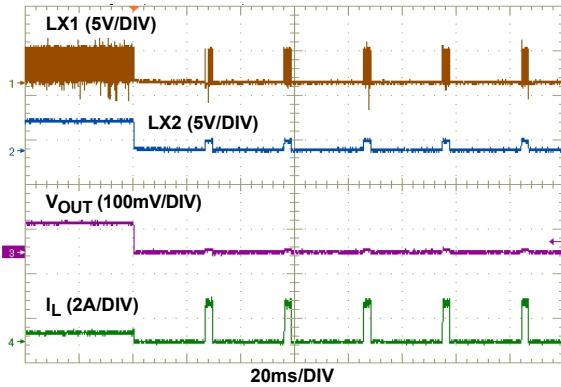

FIGURE 16. OUTPUT SHORT-CIRCUIT BEHAVIOR ( $V_{IN} = 3.6\text{V}$ ,  $V_{OUT} = 3.3\text{V}$ )

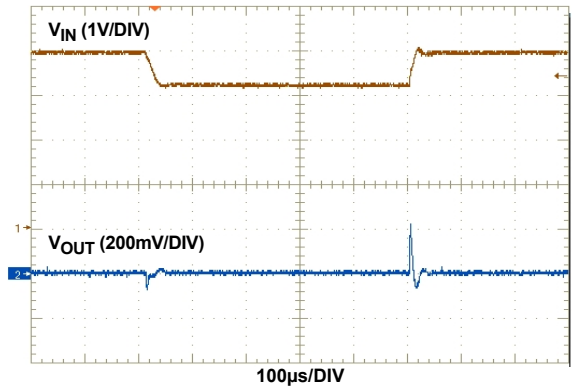

FIGURE 17. 4V TO 3.2V LINE TRANSIENT ( $V_{OUT} = 3.3\text{V}$ , LOAD = 1A)

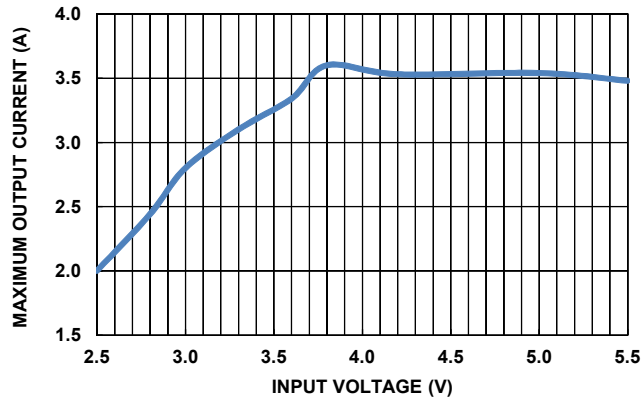

FIGURE 18. OUTPUT CURRENT CAPABILITY:  $V_{OUT} = 3.3\text{V}$ ,  $T_A = +25^\circ\text{C}$

## Functional Description

### Functional Overview

Refer to the [“Block Diagram” on page 2](#). The ISL91127IR implements a complete buck-boost switching regulator, with PWM controller, internal switches, references, protection circuitry and control inputs.

The PWM controller automatically switches between buck and boost modes as necessary to maintain a steady output voltage, with changing input voltages and dynamic external loads.

### Internal Supply and References

Referring to the [“Block Diagram” on page 2](#), the ISL91127IR provides four power input pins. The PVIN pin supplies input power to the DC/DC converter, while the VIN pin provides operating voltage source required for stable  $V_{REF}$  generation. Separate ground pins (GND and PGND) are provided to avoid problems caused by ground shift due to the high switching currents.

### Enable Input

The device is enabled by asserting the EN pin HIGH. Driving EN LOW invokes a power-down mode, where most internal device functions are disabled.

### Soft Discharge

When the device is disabled by driving EN LOW, an internal resistor between VOUT and GND is activated to slowly discharge the output capacitor. This internal resistor has a typical  $120\Omega$  resistance.

### POR Sequence and Soft-Start

Asserting the EN pin HIGH allows the device to power up. A number of events occur during the start-up sequence. The internal voltage reference powers up and stabilizes. The device then starts operating. There is a typical  $1\text{ms}$  delay between assertion of the EN pin and the start of the switching regulator soft-start ramp.

The soft-start feature minimizes output voltage overshoot and input inrush currents. During soft-start, the reference voltage is ramped to provide a ramping  $V_{OUT}$  voltage. While the output



voltage is lower than approximately 20% of the target output voltage, switching frequency is reduced to a fraction of the normal switching frequency to aid in producing low duty cycles necessary to avoid input inrush current spikes. Once the output voltage exceeds 20% of the target voltage, switching frequency is increased to its nominal value.

When the target output voltage is higher than the input voltage, there will be a transition from buck mode to boost mode during the soft-start sequence. At the time of this transition, the ramp rate of the reference voltage is decreased, such that the output voltage slew rate is decreased. This provides a slower output voltage slew rate.

The  $V_{OUT}$  ramp time is not constant for all operating conditions. Soft-start into boost mode will take longer than soft-start into buck mode. The total soft-start time into buck operating mode is typically 2ms, whereas the typical soft-start time into boost mode operating mode is typically 3ms. Increasing the load current will increase these typical soft-start times.

### Short-Circuit Protection

The ISL91127IR provides short-circuit protection by monitoring the feedback voltage. When feedback voltage is sensed to be lower than a certain threshold, the PWM oscillator frequency is reduced in order to protect the device from damage. The P-channel MOSFET peak current limit remains active during this state.

### Thermal Shutdown

A built-in thermal protection feature protects the ISL91127IR, if the die temperature reaches  $+155^{\circ}\text{C}$  (typical). At this die temperature, the regulator is completely shut down. The die temperature continues to be monitored in this thermal shutdown mode. When the die temperature falls to  $+125^{\circ}\text{C}$  (typical), the device will resume normal operation. When exiting thermal shutdown, the ISL91127IR will execute its soft-start sequence.

### Buck-Boost Conversion Topology

The ISL91127IR operates in either buck or boost mode. When operating in conditions where  $PV_{IN}$  is close to  $V_{OUT}$ , ISL91127IR alternates between buck and boost mode as necessary to provide a regulated output voltage.

[Figure 19](#) shows a simplified diagram of the internal switches and external inductor.

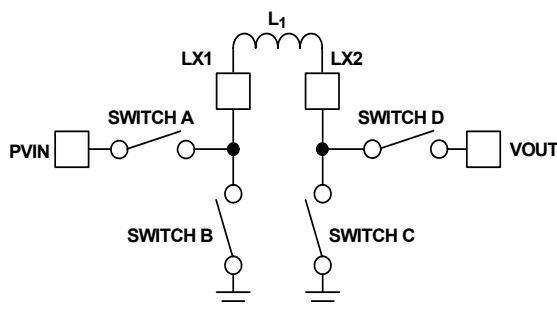

FIGURE 19. BUCK-BOOST TOPOLOGY

### PWM Operation

In Buck PWM mode, Switch D is continuously closed and Switch C is continuously open. Switches A and B operate as a synchronous buck converter when in this mode.

In Boost PWM mode, Switch A remains closed and Switch B remains open. Switches C and D operate as a synchronous boost converter when in this mode.

### PFM Operation

During PFM operation in buck mode, Switch D is continuously closed and Switch C is continuously open. Switches A and B operate in discontinuous mode during PFM operation. During PFM operation in boost mode, the ISL91127IR closes Switch A and Switch C to ramp up the current in the inductor. When the inductor current reaches a certain threshold, the device turns off Switches A and C, then turns on Switches B and D. With Switches B and D closed, output voltage increases as the inductor current ramps down.

In most operating conditions, there will be multiple PFM pulses to charge up the output capacitor. These pulses continue until  $V_{OUT}$  has achieved the upper threshold of the PFM hysteretic controller. Switching then stops, and remains stopped until  $V_{OUT}$  decays to the lower threshold of the hysteretic PFM controller.

### Operation with $V_{IN}$ Close to $V_{OUT}$

When the output voltage is close to the input voltage, the ISL91127IR will rapidly and smoothly switch from boost to buck mode as needed to maintain the regulated output voltage. This behavior provides excellent efficiency and very low output voltage ripple.

### Output Voltage Programming

The ISL91127IR is available in fixed and adjustable output voltage versions. To use the fixed output version, the  $V_{OUT}$  pin must be connected directly to FB.

In the adjustable output voltage version (ISL91127IIAZ), an external resistor divider is required to program the output voltage. The FB pin has very low input leakage current, so it is possible to use large value resistors (e.g.,  $R_1 = 1\text{M}\Omega$  and  $R_2 = 324\text{k}\Omega$  for  $V_{OUT} = 3.3\text{V}$ ) in the resistor divider connected to the FB input.

## Applications Information

### Component Selection

The fixed-output version of ISL91127IR requires only three external power components to implement the buck-boost converter: an inductor, an input capacitor and an output capacitor.

The adjustable output version of ISL91127IR requires three additional components to program the output voltage, as shown in [Figure 20](#). Two external resistors program the output voltage, and a small capacitor is added to improve stability and response.

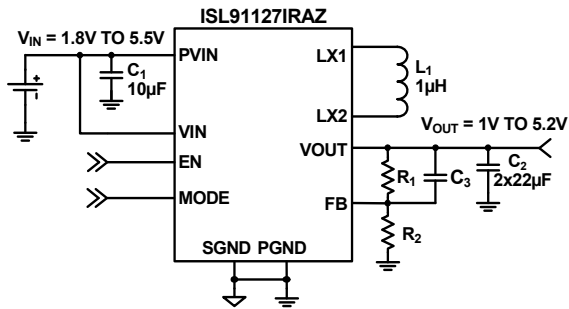

FIGURE 20. ADJUSTABLE OUTPUT APPLICATION

## Output Voltage Programming, Adjustable Version

Setting and controlling the output voltage of the ISL91127IRAZ (adjustable output version) can be accomplished by selecting the external resistor values.

Equation 1 can be used to derive the  $R_1$  and  $R_2$  resistor values:

$$V_{OUT} = 0.8V \cdot \left(1 + \frac{R_1}{R_2}\right) \quad (\text{EQ. 1})$$

When designing a PCB, include a GND guard band around the feedback resistor network to reduce noise and improve accuracy and stability. Resistors  $R_1$  and  $R_2$  should be positioned close to the FB pin.

## Feed-Forward Capacitor Selection

A small capacitor ( $C_3$  in Figure 20) in parallel with resistor  $R_1$  is required to provide the specified load and line regulation. The suggested value of this capacitor is 56pF for  $R_1 = 1M\Omega$ . An NPO type capacitor is recommended.

## Inductor Selection

An inductor with high frequency core material (e.g., ferrite core) should be used to minimize core losses and provide good efficiency. The inductor must be able to handle the peak switching currents without saturating.

A 1µH inductor with  $\geq 4A$  saturation current rating is recommended. Select an inductor with low DCR to provide good efficiency. In applications where radiated noise must be minimized, a toroidal or shielded inductor can be used.

## PVIN and VOUT Capacitor Selection

The input and output capacitors should be ceramic X5R type with low ESL and ESR. The recommended input capacitor value is 2x10µF. The recommended  $V_{OUT}$  capacitor value is 2x22µF.

TABLE 2. CAPACITOR VENDOR INFORMATION

MANUFACTURER	SERIES	WEBSITE
AVX	X5R	<a href="http://www.avx.com">www.avx.com</a>
Murata	X5R	<a href="http://www.murata.com">www.murata.com</a>
Taiyo Yuden	X5R	<a href="http://www.t-yuden.com">www.t-yuden.com</a>
TDK	X5R	<a href="http://www.tdk.com">www.tdk.com</a>

## Recommended PCB Layout

Correct PCB layout is critical for proper operation of the ISL91127IR. The input and output capacitors should be positioned as closely to the IC as possible. The ground connections of the input and output capacitors should be kept as short as possible, and should be on the component layer to avoid problems that are caused by high switching currents flowing through PCB vias.

TABLE 3. INDUCTOR VENDOR INFORMATION

MANUFACTURER	MFR. PART NUMBER	DESCRIPTION	DIMENSION (mm)	WEBSITE
Toko	1277AS-H-1R0M	1µH, 20%, DCR = 34mΩ (typical), $I_{SAT} = 4.6A$ (typical)	3.2x2.5x1.2	<a href="http://www.toko.com">www.toko.com</a>
	FDSD0312-H-1R0M	1µH, 20%, DCR = 43mΩ (typical), $I_{SAT} = 4.5A$ (typical)	3.2x3.0x1.2	
Coilcraft	XFL4020-102ME	1µH, 20%, DCR = 11mΩ (typical), $I_{SAT} = 5.1A$ (typical)	4.0x4.0x2.1	<a href="http://www.coilcraft.com">www.coilcraft.com</a>

## Revision History

The revision history provided is for informational purposes only and is believed to be accurate, but not warranted. Please go to web to make sure you have the latest revision.

DATE	REVISION	CHANGE
Aug 26, 2022	1.01	Removed Related Literature section. Updated Ordering Information table formatting. Removed About Intersil section. Updated first sentence in the Output Voltage Programming, Adjustable Version section.
Aug 3, 2016	1.00	Page 1, Features - removed Burst current bullet Page 1, Applications - added "Handheld and battery powered consumer and medical devices" bullet Page 4, Recommended Operating Conditions - removed: $V_{IN} = 3.0V$ $V_{OUT} = 3.3V$ , $t_{ON} = 600\mu s$ , $t = 4.6ms$ . . . 3A Page 8, Typical Performance Curves - added Figure 18, Output Current Capability chart.
Jun 23, 2016	0.00	Initial Release

# Package Outline Drawing

For the most recent package outline drawing, see [L20.4x4C](#).

## L20.4x4C

20 LEAD QUAD FLAT NO-LEAD PLASTIC PACKAGE

Rev 0, 11/06

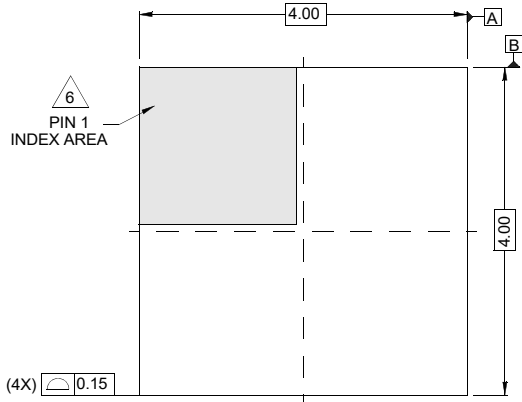

TOP VIEW

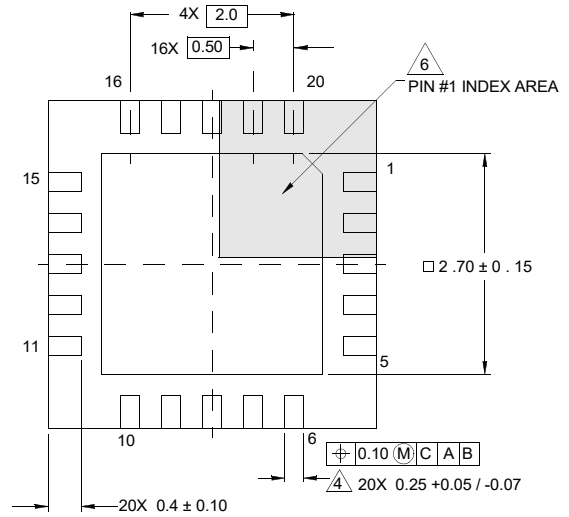

BOTTOM VIEW

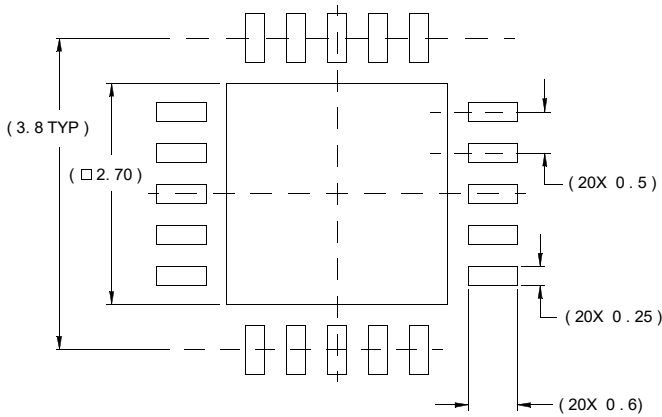

TYPICAL RECOMMENDED LAND PATTERN

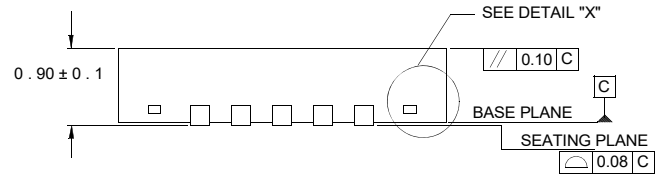

SIDE VIEW

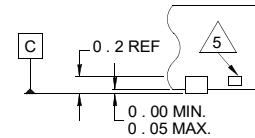

DETAIL "X"

NOTES:

1. Dimensions are in millimeters.  
Dimensions in ( ) for Reference Only.
2. Dimensioning and tolerancing conform to AMSE Y14.5m-1994.
3. Unless otherwise specified, tolerance : Decimal ± 0.05
4. Dimension b applies to the metallized terminal and is measured between 0.15mm and 0.30mm from the terminal tip.
5. Tiebar shown (if present) is a non-functional feature.
6. The configuration of the pin #1 identifier is optional, but must be located within the zone indicated. The pin #1 identifier may be either a mold or mark feature.

## IMPORTANT NOTICE AND DISCLAIMER

RENESAS ELECTRONICS CORPORATION AND ITS SUBSIDIARIES (“RENESAS”) PROVIDES TECHNICAL SPECIFICATIONS AND RELIABILITY DATA (INCLUDING DATASHEETS), DESIGN RESOURCES (INCLUDING REFERENCE DESIGNS), APPLICATION OR OTHER DESIGN ADVICE, WEB TOOLS, SAFETY INFORMATION, AND OTHER RESOURCES “AS IS” AND WITH ALL FAULTS, AND DISCLAIMS ALL WARRANTIES, EXPRESS OR IMPLIED, INCLUDING, WITHOUT LIMITATION, ANY IMPLIED WARRANTIES OF MERCHANTABILITY, FITNESS FOR A PARTICULAR PURPOSE, OR NON-INFRINGEMENT OF THIRD PARTY INTELLECTUAL PROPERTY RIGHTS.

These resources are intended for developers skilled in the art designing with Renesas products. You are solely responsible for (1) selecting the appropriate products for your application, (2) designing, validating, and testing your application, and (3) ensuring your application meets applicable standards, and any other safety, security, or other requirements. These resources are subject to change without notice. Renesas grants you permission to use these resources only for development of an application that uses Renesas products. Other reproduction or use of these resources is strictly prohibited. No license is granted to any other Renesas intellectual property or to any third party intellectual property. Renesas disclaims responsibility for, and you will fully indemnify Renesas and its representatives against, any claims, damages, costs, losses, or liabilities arising out of your use of these resources. Renesas' products are provided only subject to Renesas' Terms and Conditions of Sale or other applicable terms agreed to in writing. No use of any Renesas resources expands or otherwise alters any applicable warranties or warranty disclaimers for these products.

(Rev.1.0 Mar 2020)

### Corporate Headquarters

TOYOSU FORESIA, 3-2-24 Toyosu,  
Koto-ku, Tokyo 135-0061, Japan  
[www.renesas.com](http://www.renesas.com)

### Contact Information

For further information on a product, technology, the most up-to-date version of a document, or your nearest sales office, please visit:  
[www.renesas.com/contact/](http://www.renesas.com/contact/)

### Trademarks

Renesas and the Renesas logo are trademarks of Renesas Electronics Corporation. All trademarks and registered trademarks are the property of their respective owners.