

## Features

- **This fully integrated radio transceiver covers 863 to 928 MHz, which includes the following bands:**
  - European bands: 863 to 870, and 870 to 876 MHz
  - North American band: 902 to 928 MHz
  - Brazilian band: 902 to 907.5, and 915 to 928 MHz
  - Japanese band: 920 to 928 MHz
- **Supported types of PHY layer**
  - SUN FSK
    - Symbol rates: 10, 20, 50, 100, 150, 200 kbps
    - Forward error correction (FEC)
    - Modulation methods: 2FSK, GFSK
  - SUN OFDM
    - Option 1: 100, 200, 400, 800, 1200, 1600, 2400 kbps
    - Option 2: 50, 100, 200, 400, 600, 800, 1200 kbps
    - Option 3: 25, 50, 100, 200, 300, 400, 600 kbps
    - Option 4: 12.5, 25, 50, 100, 150, 200, 300 kbps
- **MAC**
  - 32-bit timer
  - Transmission RAM, reception RAM: 2 Kbytes each
  - Interrupt
  - 16- or 32-bit auto CRC
  - Address filtering with automatic acknowledgement reply
  - Antenna diversity
  - Auto CSMA-CA
- **Transceiver control interface: Serial peripheral interface (SPI)**
- **Radio transceiver features**
  - Programmable Tx output power up to +15 dBm in SUN FSK
  - Programmable Tx output power up to +11 dBm in SUN OFDM
  - Receiver sensitive down to -109 dBm in 50-kbps SUN-FSK reception
  - Receiver sensitive down to -119 dBm in option-4 MCS0 SUN OFDM

- Received signal strength indicator, energy detection
- Internal voltage regulators
- Operating voltage: 2.7 to 3.6 V
- Low power consumption (incl. for baseband processing)
  - Standby: 0.5  $\mu$ A
  - Rx active: 16.7 mA for SUN FSK (2GFSK) at 100 kbps
  - Rx active: 21.5 mA for SUN OFDM, option 1, MCS6
  - Tx active: 62.0 mA for SUN-FSK +15-dBm output power
  - Tx active: 68.0 mA for SUN-OFDM +10-dBm output power
- Operating ambient temperature: -40 to +85°C
- Package: 40-pin HVQFN (6 x 6, 0.5-mm pitch)

## Applications

- Smart meter (electricity, gas, tap water) supporting products IEEE 802.15.4, Wi-SUN™
- HEMS controller
- Security and building automation
- Industrial monitoring and control
- Wireless sensor networks
- Energy-harvesting applications, and others

## Contents

<b>1. Overview</b>	<b>13</b>
1.1 Block Diagram	13
<b>2. Pin Information</b>	<b>14</b>
2.1 Pin Assignments	14
2.2 Pin Descriptions	15
<b>3. Specifications</b>	<b>17</b>
3.1 Absolute Maximum Ratings	17
3.2 Recommended Operating Conditions	17
3.3 Specifications of the Crystal Resonator	18
3.4 DC Characteristics	18
3.4.1 Digital input/output pins	18
3.5 AC Characteristics	19
3.5.1 Serial peripheral interface (SPI)	19
3.6 Characteristics of the Power Supply Current	20
3.7 Characteristics of the Transceiver Reception	21
3.7.1 Reception sensitivity for SUN FSK	21
3.7.2 Adjacent channel rejection ratio for SUN FSK	22
3.7.3 Alternate channel rejection ratio for SUN FSK	23
3.7.4 Characteristics of the SUN-FSK reception	23
3.7.5 Reception sensitivity for SUN OFDM	24
3.7.6 Adjacent channel rejection ratio for SUN OFDM	24
3.7.7 Alternate channel rejection ratio for SUN OFDM	24
3.7.8 Co-channel rejection ratio for SUN OFDM	25
3.7.9 Characteristics of the SUN-OFDM reception	25
3.8 Characteristics of Transceiver Transmission	26
3.8.1 Characteristics of the SUN-FSK transmission	26
3.8.2 Characteristics of the SUN-OFDM transmission	27
3.9 Specifications of the Data Rate	28
3.10 Compliant Standard	28
<b>4. Registers</b>	<b>29</b>
4.1 Register Map	29
4.2 Register Descriptions	37
4.2.1 RF start register (BBRFCON)	37
4.2.2 Transmission and reception reset register (BBTXRXRST)	39
4.2.3 Transmission and reception mode register 0 (BBTXRXMODE0)	40
4.2.4 Transmission and reception mode register 1 (BBTXRXMODE1)	42
4.2.5 RXIDLE mode register (BBRXIDLE)	43
4.2.6 High-speed reception switching mode register (BBRXMODE)	44
4.2.7 Enhanced ACK mode register (BBEACKMODE)	45
4.2.8 Transmission and reception status register 0 (BBTXRXST0)	46
4.2.9 Transmission and reception mode register 2 (BBTXRXMODE2)	48
4.2.10 Transmission and reception mode register 3 (BBTXRXMODE3)	49
4.2.11 Transmission and reception status register 1 (BBTXRXST1)	51

4.2.12	Transmission and reception control register (BBTXRXCON) .....	52
4.2.13	CSMA control register 0 (BBCSMACON0) .....	53
4.2.14	Transmission and reception status register 2 (BBTXRXST2).....	55
4.2.15	Transmission and reception mode register 4 (BBTXRXMODE4) .....	56
4.2.16	CSMA control register 1 (BBCSMACON1) .....	57
4.2.17	CSMA control register 2 (BBCSMACON2) .....	58
4.2.18	PAN identifier register 0 (BBPANID0).....	59
4.2.19	Short address register 0 (BBSHORTAD0).....	60
4.2.20	Extended address registers 0 (BBEXTENDAD00 to BBEXTENDAD03).....	61
4.2.21	Timer read registers 0 and 1 (BBTIMEREAD0 and BBTIMEREAD1) .....	63
4.2.22	Timer comparison registers 0 and 1 (BBTCOMP0REG0 to BBTCOMP2REG0 and BBTCOMP0REG1 to BBTCOMP2REG1).....	64
4.2.23	Timestamp registers 0 and 1 (BBTSTAMP0 and BBTSTAMP1).....	66
4.2.24	Timer control register (BBTIMECON) .....	67
4.2.25	Backoff period register (BBBOFFPROD).....	69
4.2.26	Timing parameter data rate setting register (BBPARAMRATE) .....	70
4.2.27	Extended data rate setting register (BBEXTRATE) .....	71
4.2.28	CSMA control register 3 (BBCSMACON3) .....	72
4.2.29	Calibration register (BBCAL).....	73
4.2.30	ACK reply time setting register (ACKRTNTIM) .....	74
4.2.31	Automatic switching to reception comparison register (AUTORCVCNT) .....	75
4.2.32	Backoff cycle register (BOFFPERIOD) .....	76
4.2.33	CSMA-CA end count register (CSMAENDCOUNT) .....	77
4.2.34	CSMA-CA start count register (CSMASTACOUNT) .....	78
4.2.35	Communication status register 1 (COMSTATE1).....	79
4.2.36	Communication status register 2 (COMSTATE2).....	80
4.2.37	Evaluation control register (BBEVAREG) .....	81
4.2.38	Backoff period register 2 (BBBOFFPROD2).....	82
4.2.39	Communication status register 3 (COMSTATE3).....	83
4.2.40	ACK reception wait time setting register (ACKRCVWIT).....	84
4.2.41	Retransmission start comparison register (RETRNWUP) .....	85
4.2.42	Received frame length register (BBRXFLEN).....	86
4.2.43	Received data counter register (BBRXCOUNT) .....	87
4.2.44	Transmitted frame length register (BBTXFLEN) .....	88
4.2.45	Frequency setting register (BBFREQ) .....	89
4.2.46	IF frequency setting register (BBIFSET) .....	90
4.2.47	SX shift frequency setting register (BBSXSFTFREQ) .....	91
4.2.48	CCA time register (CCATIME) .....	92
4.2.49	IF frequency offset setting register 0 (BBIFOFST0) .....	93
4.2.50	IF frequency offset setting register 1 (BBIFOFST1) .....	94
4.2.51	Transmitted data counter register (BBTXCOUNT) .....	95
4.2.52	External device control register 0 (BBEXTCON0) .....	96
4.2.53	External device control register 1 (BBEXTCON1) .....	98
4.2.54	CTX set timing register (BBCTXSET) .....	99
4.2.55	CTX clear timing register (BBCTXCLR).....	100
4.2.56	CPS set timing register (BBCPSSET).....	101

4.2.57	CPS clear timing register (BBCPSCLR) .....	102
4.2.58	CSD set timing register (BBCSDSET) .....	103
4.2.59	CSD clear timing register (BBCSDCLR) .....	104
4.2.60	Number-of-received-byte interrupt comparison register (BBRCVINTCOMP).....	105
4.2.61	Backoff period total number register (BBBOPTOTAL) .....	106
4.2.62	CCA total number register (BBCCATOTAL) .....	107
4.2.63	Address filter extension address control register (BBADFCON) .....	108
4.2.64	PAN identifier register 1 (BBPANID1).....	110
4.2.65	Short address register 1 (BBSHORTAD1).....	111
4.2.66	Extended address registers 1 (BBEXTENDAD10 to BBEXTENDAD13).....	112
4.2.67	Reception timeout register (BBTIMEOUT).....	114
4.2.68	INTOUT mode register (BBINTOUTMODE) .....	115
4.2.69	INTOUT0 interrupt source register 0 (BBINT0REQ0).....	117
4.2.70	INTOUT0 interrupt source register 1 (BBINT0REQ1).....	119
4.2.71	INTOUT0 interrupt source register 2 (BBINT0REQ2).....	121
4.2.72	INTOUT0 interrupt source register 3 (BBINT0REQ3).....	123
4.2.73	INTOUT0 interrupt source register 4 (BBINT0REQ4).....	125
4.2.74	INTOUT0 interrupt source register 5 (BBINT0REQ5).....	127
4.2.75	INTOUT0 interrupt source register 6 (BBINT0REQ6).....	129
4.2.76	INTOUT0 interrupt source register 7 (BBINT0REQ7).....	131
4.2.77	INTOUT0 interrupt enable register 0 (BBINT0EN0) .....	133
4.2.78	INTOUT0 interrupt enable register 1 (BBINT0EN1) .....	135
4.2.79	INTOUT0 interrupt enable register 2 (BBINT0EN2) .....	137
4.2.80	INTOUT0 interrupt enable register 3 (BBINT0EN3) .....	139
4.2.81	INTOUT0 interrupt enable register 4 (BBINT0EN4) .....	140
4.2.82	INTOUT0 interrupt enable register 5 (BBINT0EN5) .....	142
4.2.83	INTOUT0 interrupt enable register 6 (BBINT0EN6) .....	144
4.2.84	INTOUT0 interrupt enable register 7 (BBINT0EN7) .....	146
4.2.85	INTOUT0 interrupt source enable register 0 (BBINT0REQEN0).....	148
4.2.86	INTOUT0 interrupt source enable register 1 (BBINT0REQEN1).....	150
4.2.87	INTOUT0 interrupt source enable register 2 (BBINT0REQEN2).....	152
4.2.88	INTOUT0 interrupt source enable register 3 (BBINT0REQEN3).....	154
4.2.89	INTOUT0 interrupt source enable register 4 (BBINT0REQEN4).....	156
4.2.90	INTOUT0 interrupt source enable register 5 (BBINT0REQEN5).....	158
4.2.91	INTOUT0 interrupt source enable register 6 (BBINT0REQEN6).....	160
4.2.92	INTOUT0 interrupt source enable register 7 (BBINT0REQEN7).....	162
4.2.93	Number-of-transmitted-byte interrupt comparison register (BBTRNINTCOMP).....	164
4.2.94	CCA mode register (BBCCAMODE).....	165
4.2.95	Receive mode register (BBRCVMODE) .....	167
4.2.96	Frame cancellation minimum length register (BBFLCNCLMIN) .....	168
4.2.97	Frame cancellation maximum length register (BBFLCNCLMAX) .....	169
4.2.98	Number-of-byte interrupt mode register (BBBYTEINTMODE) .....	170
4.2.99	RSSI result register (BBRSSIRSLT) .....	171
4.2.100	RCPI result register (BBRCPIRSLT).....	172
4.2.101	RSSI result 2 register (BBRSSIRSLT2) .....	173
4.2.102	RCPI result 2 register (BBRCPIRSLT2).....	174

4.2.103	ED1 result register (BBED1RSLT).....	175
4.2.104	ED2 result register (BBED2RSLT).....	176
4.2.105	ED1 result 2 register (BBED1RSLT2).....	177
4.2.106	ED2 result 2 register (BBED2RSLT2).....	178
4.2.107	CCA clearance count register (BBCCACLRCOUNT) .....	179
4.2.108	CCA limit setting register (BBCCALIMIT) .....	180
4.2.109	Comparison 0 setting excess time registers (BBPASSTIME0 and BBPASSTIME1) .....	181
4.2.110	Frame synchronization power value read register (BBFSYNCPOWRD) .....	182
4.2.111	Frame synchronization power value 2 read register (BBFSYNCPOWRD2) .....	183
4.2.112	RSSI read register (BBRSSIRD).....	184
4.2.113	RCPI read register (BBRCPIRD) .....	185
4.2.114	RSSI read 2 register (BBRSSIRD2).....	186
4.2.115	RCPI read 2 register (BBRCPIRD2) .....	187
4.2.116	Transmission and reception method selection register (BBTRXSEL) .....	188
4.2.117	Reception method check register (BBRXMODEMONI) .....	189
4.2.118	Reception prohibition register (BBRXPROHIBIT) .....	190
4.2.119	Received frame counter control register (BBRCVCOUNTCNT).....	191
4.2.120	Total reception counter (BBRCVCOUNT).....	193
4.2.121	PHR error counter (BBPHRERRCOUNT).....	194
4.2.122	Number-of-successful-receptions counter (BBRCVOKCOUNT) .....	195
4.2.123	Number-of-unsuccessful-receptions counter (BBRCVNGCOUNT) .....	196
4.2.124	Frame synchronization power value result register (BBFSYNCPOWRSLT) .....	197
4.2.125	Frame synchronization power value result 2 register (BBFSYNCPOWRSLT2) .....	198
4.2.126	CCA data rate control register (BBCCARATECON) .....	199
4.2.127	FSK control register 0 (BBFSKCON0) .....	201
4.2.128	FSK control register 1 (BBFSKCON1) .....	202
4.2.129	FSK control register 2 (BBFSKCON2) .....	204
4.2.130	FSKFEC control register (BBFSKFECCON).....	205
4.2.131	Mode switch frame transmission register (BBTXMODESW) .....	207
4.2.132	Mode switch frame reception register (BBRXMODESW) .....	208
4.2.133	Mode switch status register (BBMSSTATE) .....	209
4.2.134	Mode switch frame control register (BBMSSCON) .....	210
4.2.135	FSKCCA level threshold setting register (BBFSKCCAETH) .....	211
4.2.136	FSK reception level threshold setting register (BBFSKLVLVTH) .....	212
4.2.137	FSKPHR reception register (BBFSKPHRRX).....	213
4.2.138	OFDM control register (BBOFDMCON).....	214
4.2.139	OFDMPHR transmission register 0 (BBOFDMPHRTX0) .....	215
4.2.140	OFDMPHR transmission register 1 (BBOFDMPHRTX1) .....	216
4.2.141	OFDMPHRACK reply register 0 (BBOFDMPHRACK0).....	217
4.2.142	OFDMPHRACK reply register 1 (BBOFDMPHRACK1).....	218
4.2.143	OFDMPHR reception register 0 (BBOFDMPHRRX0) .....	219
4.2.144	OFDMPHR reception register 1 (BBOFDMPHRRX1) .....	220
4.2.145	OFDMPHR reception register 2 (BBOFDMPHRRX2) .....	221
4.2.146	OFDMCCA level threshold setting register (BBOFDMCCAETH) .....	223
4.2.147	OFDM reception level threshold setting register (BBOFDMMLLVTH) .....	224
4.2.148	Port direction register 0 (GPIODIR0) .....	225

4.2.149	Port direction register 1 (GPIODIR1) .....	226
4.2.150	Port data register 0 (GPIODATA0) .....	227
4.2.151	Port data register 1 (GPIODATA1) .....	229
4.2.152	Port output driving capability switching register 0 (GPIODRV0).....	230
4.2.153	Port output driving capability switching register 1 (GPIODRV1).....	231
4.2.154	Pull-up/pull-down selection register 0 (PULLSEL0).....	232
4.2.155	Pull-up/pull-down selection register 1 (PULLSEL1).....	234
4.2.156	Pull-up/pull-down selection register 2 (PULLSEL2).....	236
4.2.157	Pull-up/pull-down selection register 3 (PULLSEL3).....	238
4.2.158	GPIO function selection register 0 (BBGPIOFUNCSEL0) .....	240
4.2.159	GPIO function selection register 1 (BBGPIOFUNCSEL1) .....	241
4.2.160	GPIO function selection register 2 (BBGPIOFUNCSEL2) .....	242
4.2.161	GPIO function selection register 3 (BBGPIOFUNCSEL3) .....	243
4.2.162	GPIO function selection register 4 (BBGPIOFUNCSEL4) .....	244
4.2.163	GPIO function selection register 5 (BBGPIOFUNCSEL5) .....	245
4.2.164	GPIO function selection register 6 (BBGPIOFUNCSEL6) .....	246
4.2.165	RX-state OSC setting register (BBRXOSC).....	247
4.2.166	NEWMODE transmission control register (BBNMTXCON) .....	248
4.2.167	NEWMODE Transmission SX shift frequency setting register (BBNMTXSXSFTFREQ) ...	250
4.2.168	NEWMODE transmission frequency setting register (BBNMTXFREQ).....	251
4.2.169	NEWMODE transmission FSK control register 0 (BBNMTXFSKCON0) .....	252
4.2.170	NEWMODE transmission FSK control register 1 (BBNMTXFSKCON1) .....	253
4.2.171	NEWMODE reception control register 0 (BBNMRXCON0) .....	255
4.2.172	NEWMODE reception control register 1 (BBNMRXCON1) .....	256
4.2.173	NEWMODE reception control register 2 (BBNMRXCON2) .....	257
4.2.174	NEWMODE reception frequency setting register (BBNMRXBBFREQ).....	259
4.2.175	NEWMODE reception FSK control register 0 (BBNMRXFSKCON0) .....	260
4.2.176	NEWMODE reception FSK control register 1 (BBNMRXFSKCON1) .....	261
4.2.177	NEWMODE reception OFDM control register (BBNMRXOFDMCON).....	263
4.2.178	Preamble length setting register (BBPAMBL).....	265
4.2.179	Preamble setting register (BBPABL).....	266
4.2.180	TXSFD setting register (BBTXSFD).....	267
4.2.181	TXSFD setting register 2 (BBTXSFD2).....	268
4.2.182	TXSFD setting register 3 (BBTXSFD3).....	269
4.2.183	TXSFD setting register 4 (BBTXSFD4).....	270
4.2.184	SHR control register (BBSHRCON).....	271
4.2.185	NEWMODE transmission FSK preamble length setting register (BBMSPAMBL) .....	272
4.2.186	Version code read control register (VERCNT).....	273
4.2.187	Version registers (VERR0 to VERR7).....	274
4.2.188	RXSFD setting register 2 (BBRXSFD2).....	276
4.2.189	RXSFD setting register (BBRXSFD).....	277
4.2.190	RXSFD setting register 4 (BBRXSFD4).....	278
4.2.191	RXSFD setting register 3 (BBRXSFD3).....	279
<b>5.</b>	<b>Package Outline Drawings.....</b>	<b>280</b>
<b>6.</b>	<b>Ordering Information.....</b>	<b>281</b>

## Figures

Figure 1-1 Block diagram.....	13
Figure 2-1 Pin Assignments – Top View .....	14
Figure 4-1 Format of RF Start Register (BBRFCON).....	37
Figure 4-2 Areas Switched by the Register Access Area Switch Bit.....	38
Figure 4-3 Format of Transmission and Reception Reset Register (BBTXRXRST) .....	39
Figure 4-4 Format of Transmission and Reception Mode Register 0 (BBTXRXMODE0).....	41
Figure 4-5 Format of Transmission and Reception Mode Register 1 (BBTXRXMODE1).....	42
Figure 4-6 Format of RXIDLE Mode Register (BBRXIDLE) .....	43
Figure 4-7 Format of High-Speed Reception Switching Mode Register (BBRXMODE) .....	44
Figure 4-8 Format of Enhanced ACK Mode Register (BBEACKMODE).....	45
Figure 4-9 Format of Transmission and Reception Status Register 0 (BBTXRXST0).....	47
Figure 4-10 Format of Transmission and Reception Mode Register 2 (BBTXRXMODE2).....	48
Figure 4-11 Format of Transmission and Reception Mode Register 3 (BBTXRXMODE3).....	50
Figure 4-12 Format of Transmission and Reception Status Register 1 (BBTXRXST1).....	51
Figure 4-13 Format of Transmission and Reception Control Register (BBTXRXCON).....	52
Figure 4-14 Format of CSMA Control Register 0 (BBCSMACON0).....	54
Figure 4-15 Format of Transmission and Reception Status Register 2 (BBTXRXST2).....	55
Figure 4-16 Format of Transmission and Reception Mode Register 4 (BBTXRXMODE4).....	56
Figure 4-17 Format of CSMA Control Register 1 (BBCSMACON1).....	57
Figure 4-18 Format of CSMA Control Register 2 (BBCSMACON2).....	58
Figure 4-19 Format of PAN Identifier Register 0 (BBPANID0) .....	59
Figure 4-20 Format of Short Address Register 0 (BBSHORTAD0).....	60
Figure 4-21 Format of Extended Address Registers 0 (BBEXTENDAD00 to BBEXTENDAD03) (1/2) .....	61
Figure 4-22 Format of Extended Address Registers 0 (BBEXTENDAD00 to BBEXTENDAD03) (2/2) .....	62
Figure 4-23 Format of Timer Read Register 0 (BBTIMEREAD0).....	63
Figure 4-24 Format of Timer Read Register 1 (BBTIMEREAD1).....	63
Figure 4-25 Format of Timer Comparison Registers 0 (BBTCOMPnREG0).....	64
Figure 4-26 Format of Timer Comparison Registers 1 (BBTCOMPnREG1).....	65
Figure 4-27 Format of Timestamp Register 0 (BBTSTAMP0).....	66
Figure 4-28 Format of Timestamp Register 1 (BBTSTAMP1).....	66
Figure 4-29 Format of Timer Control Register (BBTIMECON).....	68
Figure 4-30 Format of Backoff Period Register (BBBOFFPROD).....	69
Figure 4-31 Format of Timing Parameter Data Rate Setting Register (BBPARAMRATE) .....	70
Figure 4-32 Format of Extended Data Rate Setting Register (BBEXTRATE).....	71
Figure 4-33 Format of CSMA Control Register 3 (BBCSMACON3).....	72
Figure 4-34 Format of Calibration Register (BBCAL) .....	73
Figure 4-35 Format of ACK Reply Time Setting Register (ACKRTNTIM) .....	74
Figure 4-36 Count Operation in the Non-Beacon Mode.....	74
Figure 4-37 Format of Automatic Switching to Reception Comparison Register (AUTORCVCNT) .....	75
Figure 4-38 Count Operation Specified by the Automatic Switching to Reception Comparison Register .....	75
Figure 4-39 Format of Backoff Cycle Register (BOFFPERIOD) .....	76
Figure 4-40 Format of CSMA-CA End Count Register (CSMAENDCOUNT) .....	77
Figure 4-41 Format of CSMA-CA Start Count Register (CSMASTACOUNT).....	78
Figure 4-42 Format of Communication Status Register 1 (COMSTATE1) .....	79

Figure 4-43 Format of Communication Status Register 2 (COMSTATE2) .....	80
Figure 4-44 Format of Evaluation Control Register (BBEVAREG).....	81
Figure 4-45 Format of Backoff Period Register 2 (BBBOFFPROD2).....	82
Figure 4-46 Format of Communication Status Register 3 (COMSTATE3) .....	83
Figure 4-47 Format of ACK Reception Wait Time Setting Register (ACKRCVWIT) .....	84
Figure 4-48 Format of Retransmission Start Comparison Register (RETRNWUP) .....	85
Figure 4-49 Format of Received Frame Length Register (BBRXFLEN) .....	86
Figure 4-50 Format of Received Data Counter Register (BBRXCOUNT).....	87
Figure 4-51 Format of Transmitted Frame Length Register (BBTXFLEN).....	88
Figure 4-52 Format of Frequency Setting Register (BBFREQ).....	89
Figure 4-53 Format of IF Frequency Setting Register (BBIFSET) .....	90
Figure 4-54 Format of SX Shift Frequency Setting Register (BBSXSFTFREQ) .....	91
Figure 4-55 Format of CCA Time Register (CCATIME) .....	92
Figure 4-56 Format of IF Frequency Offset Setting Register 0 (BBIFOFS0) .....	93
Figure 4-57 Format of IF Frequency Offset Setting Register 1 (BBIFOFS1) .....	94
Figure 4-58 Format of Transmitted Data Counter Register (BBTXCOUNT) .....	95
Figure 4-59 Format of External Device Control Register 0 (BBEXTCON0) .....	97
Figure 4-60 Format of External Device Control Register 1 (BBEXTCON1) .....	98
Figure 4-61 Format of CTX Set Timing Register (BBCTXSET) .....	99
Figure 4-62 Format of CTX Clear Timing Register (BBCTXCLR) .....	100
Figure 4-63 Format of CPS Set Timing Register (BBCPSSET) .....	101
Figure 4-64 Format of CPS Clear Timing Register (BBCPSCLR).....	102
Figure 4-65 Format of CSD Set Timing Register (BBCSDSET).....	103
Figure 4-66 Format of CSD Clear Timing Register (BBCSDCLR) .....	104
Figure 4-67 Format of Number-of-Received-Byte Interrupt Comparison Register (BBRCVINTCOMP) .....	105
Figure 4-68 Format of Backoff Period Total Number Register (BBBOPTOTAL) .....	106
Figure 4-69 Format of CCA Total Number Register (BBCCATOTAL) .....	107
Figure 4-70 Format of Address Filter Extension Address Control Register (BBADFCON).....	109
Figure 4-71 Format of PAN Identifier Register 1 (BBPANID1).....	110
Figure 4-72 Format of Short Address Register 1 (BBSHORTAD1).....	111
Figure 4-73 Format of Extended Address Registers 1 (BBEXTENDAD10 to BBEXTENDAD13) (1/2) .....	112
Figure 4-74 Format of Extended Address Registers 1 (BBEXTENDAD10 to BBEXTENDAD13) (2/2).....	113
Figure 4-75 Format of Reception Timeout Register (BBTIMEOUT).....	114
Figure 4-76 Format of INTOOUT Mode Register (BBINTOUTMODE) .....	116
Figure 4-77 Format of INTOOUT0 Interrupt Source Register 0 (BBINT0REQ0) (1/2).....	117
Figure 4-78 Format of INTOOUT0 Interrupt Source Register 0 (BBINT0REQ0) (2/2).....	118
Figure 4-79 Format of INTOOUT0 Interrupt Source Register 1 (BBINT0REQ1) (1/2).....	119
Figure 4-80 Format of INTOOUT0 Interrupt Source Register 1 (BBINT0REQ1) (2/2).....	120
Figure 4-81 Format of INTOOUT0 Interrupt Source Register 2 (BBINT0REQ2) (1/2).....	121
Figure 4-82 Format of INTOOUT0 Interrupt Source Register 2 (BBINT0REQ2) (2/2).....	122
Figure 4-83 Format of INTOOUT0 Interrupt Source Register 3 (BBINT0REQ3) (1/2).....	123
Figure 4-84 Format of INTOOUT0 Interrupt Source Register 3 (BBINT0REQ3) (2/2).....	124
Figure 4-85 Format of INTOOUT0 Interrupt Source Register 4 (BBINT0REQ4) (1/2).....	125
Figure 4-86 Format of INTOOUT0 Interrupt Source Register 4 (BBINT0REQ4) (2/2).....	126
Figure 4-87 Format of INTOOUT0 Interrupt Source Register 5 (BBINT0REQ5) (1/2).....	127
Figure 4-88 Format of INTOOUT0 Interrupt Source Register 5 (BBINT0REQ5) (2/2).....	128



---

Figure 4-89 Format of INTOOUT0 Interrupt Source Register 6 (BBINT0REQ6) (1/2).....	129
Figure 4-90 Format of INTOOUT0 Interrupt Source Register 6 (BBINT0REQ6) (2/2).....	130
Figure 4-91 Format of INTOOUT0 Interrupt Source Register 7 (BBINT0REQ7) (1/2).....	131
Figure 4-92 Format of INTOOUT0 Interrupt Source Register 7 (BBINT0REQ7) (2/2).....	132
Figure 4-93 Format of INTOOUT0 Interrupt Enable Register 0 (BBINT0EN0) (1/2).....	133
Figure 4-94 Format of INTOOUT0 Interrupt Enable Register 0 (BBINT0EN0) (2/2).....	134
Figure 4-95 Format of INTOOUT0 Interrupt Enable Register 1 (BBINT0EN1) (1/2).....	135
Figure 4-96 Format of INTOOUT0 Interrupt Enable Register 1 (BBINT0EN1) (2/2).....	136
Figure 4-97 Format of INTOOUT0 Interrupt Enable Register 2 (BBINT0EN2) (1/2).....	137
Figure 4-98 Format of INTOOUT0 Interrupt Enable Register 2 (BBINT0EN2) (2/2).....	138
Figure 4-99 Format of INTOOUT0 Interrupt Enable Register 3 (BBINT0EN3) .....	139
Figure 4-100 Format of INTOOUT0 Interrupt Enable Register 4 (BBINT0EN4) (1/2).....	140
Figure 4-101 Format of INTOOUT0 Interrupt Enable Register 4 (BBINT0EN4) (2/2).....	141
Figure 4-102 Format of INTOOUT0 Interrupt Enable Register 5 (BBINT0EN5) (1/2).....	142
Figure 4-103 Format of INTOOUT0 Interrupt Enable Register 5 (BBINT0EN5) (2/2).....	143
Figure 4-104 Format of INTOOUT0 Interrupt Enable Register 6 (BBINT0EN6) (1/2).....	144
Figure 4-105 Format of INTOOUT0 Interrupt Enable Register 6 (BBINT0EN6) (2/2).....	145
Figure 4-106 Format of INTOOUT0 Interrupt Enable Register 7 (BBINT0EN7) (1/2).....	146
Figure 4-107 Format of INTOOUT0 Interrupt Enable Register 7 (BBINT0EN7) (2/2).....	147
Figure 4-108 Format of INTOOUT0 Interrupt Source Enable Register 0 (BBINT0REQEN0) (1/2) .....	148
Figure 4-109 Format of INTOOUT0 Interrupt Source Enable Register 0 (BBINT0REQEN0) (2/2) .....	149
Figure 4-110 Format of INTOOUT0 Interrupt Source Enable Register 1 (BBINT0REQEN1) (1/2) .....	150
Figure 4-111 Format of INTOOUT0 Interrupt Source Enable Register 1 (BBINT0REQEN1) (2/2) .....	151
Figure 4-112 Format of INTOOUT0 Interrupt Source Enable Register 2 (BBINT0REQEN2) (1/2) .....	152
Figure 4-113 Format of INTOOUT0 Interrupt Source Enable Register 2 (BBINT0REQEN2) (2/2) .....	153
Figure 4-114 Format of INTOOUT0 Interrupt Source Enable Register 3 (BBINT0REQEN3) (1/2) .....	154
Figure 4-115 Format of INTOOUT0 Interrupt Source Enable Register 3 (BBINT0REQEN3) (2/2) .....	155
Figure 4-116 Format of INTOOUT0 Interrupt Source Enable Register 4 (BBINT0REQEN4) (1/2) .....	156
Figure 4-117 Format of INTOOUT0 Interrupt Source Enable Register 4 (BBINT0REQEN4) (2/2) .....	157
Figure 4-118 Format of INTOOUT0 Interrupt Source Enable Register 5 (BBINT0REQEN5) (1/2) .....	158
Figure 4-119 Format of INTOOUT0 Interrupt Source Enable Register 5 (BBINT0REQEN5) (2/2) .....	159
Figure 4-120 Format of INTOOUT0 Interrupt Source Enable Register 6 (BBINT0REQEN6) (1/2) .....	160
Figure 4-121 Format of INTOOUT0 Interrupt Source Enable Register 6 (BBINT0REQEN6) (2/2) .....	161
Figure 4-122 Format of INTOOUT0 Interrupt Source Enable Register 7 (BBINT0REQEN7) (1/2) .....	162
Figure 4-123 Format of INTOOUT0 Interrupt Source Enable Register 7 (BBINT0REQEN7) (2/2) .....	163
Figure 4-124 Format of Number-of-Transmitted-Byte Interrupt Comparison Register (BBTRNINTCOMP) .....	164
Figure 4-125 Format of CCA Mode Register (BBCCAMODE) (1/2).....	165
Figure 4-126 Format of CCA Mode Register (BBCCAMODE) (2/2).....	166
Figure 4-127 Format of Receive Mode Register (BBRCVMODE).....	167
Figure 4-128 Format of Frame Cancellation Minimum Length Register (BBFLCNCLMIN) .....	168
Figure 4-129 Format of Frame Cancellation Maximum Length Register (BBFLCNCLMAX) .....	169
Figure 4-130 Format of Number-of-Byte Interrupt Mode Register (BBBYTEINTMODE) .....	170
Figure 4-131 Format of RSSI Result Register (BBRSSIRSLT) .....	171
Figure 4-132 Format of RCPI Result Register (BBRCPIRSLT) .....	172
Figure 4-133 Format of RSSI Result 2 Register (BBRSSIRSLT2).....	173
Figure 4-134 Format of RCPI Result 2 Register (BBRCPIRSLT2) .....	174

---

Figure 4-135 Format of ED1 Result Register (BBED1RSLT).....	175
Figure 4-136 Format of ED2 Result Register (BBED2RSLT).....	176
Figure 4-137 Format of ED1 Result 2 Register (BBED1RSLT2).....	177
Figure 4-138 Format of ED2 Result 2 Register (BBED2RSLT2).....	178
Figure 4-139 Format of CCA Clearance Count Register (BBCCACLRCOUNT).....	179
Figure 4-140 Format of CCA Limit Setting Register (BBCCALIMIT).....	180
Figure 4-141 Format of Comparison 0 Setting Excess Time Registers (BBPASSTIME0 and BBPASSTIME1) .	181
Figure 4-142 Format of Frame Synchronization Power Value Read Register (BBFSYNCPOWRD).....	182
Figure 4-143 Format of Frame Synchronization Power Value 2 Read Register (BBFSYNCPOWRD2).....	183
Figure 4-144 Format of RSSI Read Register (BBRSSIRD) .....	184
Figure 4-145 Format of RCPI Read Register (BBRCPIRD) .....	185
Figure 4-146 Format of RSSI Read 2 Register (BBRSSIRD2) .....	186
Figure 4-147 Format of RCPI Read 2 Register (BBRCPIRD2) .....	187
Figure 4-148 Format of Transmission and Reception Method Selection Register (BBTRXSEL) .....	188
Figure 4-149 Format of Reception Method Check Register (BBRXMODEMONI) .....	189
Figure 4-150 Format of Reception Prohibition Register (BBRXPROHIBIT).....	190
Figure 4-151 Format of Received Frame Counter Control Register (BBRCVCOUNTCNT) (1/2).....	191
Figure 4-152 Format of Received Frame Counter Control Register (BBRCVCOUNTCNT) (2/2).....	192
Figure 4-153 Format of Total Reception Counter (BBRCVCOUNT) .....	193
Figure 4-154 Format of PHR Error Counter (BBPHRERRCOUNT) .....	194
Figure 4-155 Format of Number-of-Successful-Receptions Counter (BBRCVOKCOUNT).....	195
Figure 4-156 Format of Number-of-Unsuccessful-Receptions Counter (BBRCVNGCOUNT).....	196
Figure 4-157 Format of Frame Synchronization Power Value Result Register (BBFSYNCPOWRSLT) .....	197
Figure 4-158 Format of Frame Synchronization Power Value Result 2 Register (BBFSYNCPOWRSLT2) .....	198
Figure 4-159 Format of CCA Data Rate Control Register (BBCCARATECON) (1/2).....	199
Figure 4-160 Format of CCA Data Rate Control Register (BBCCARATECON) (2/2).....	200
Figure 4-161 Format of FSK Control Register 0 (BBFSKCON0) .....	201
Figure 4-162 Format of FSK Control Register 1 (BBFSKCON1) (1/2).....	202
Figure 4-163 Format of FSK Control Register 1 (BBFSKCON1) (2/2).....	203
Figure 4-164 Format of FSK Control Register 2 (BBFSKCON2) .....	204
Figure 4-165 Format of FSKFEC Control Register (BBFSKFECCON) (1/2) .....	205
Figure 4-166 Format of FSKFEC Control Register (BBFSKFECCON) (2/2) .....	206
Figure 4-167 Format of Mode Switch Frame Transmission Register (BBTXMODESW) .....	207
Figure 4-168 Format of Mode Switch Frame Reception Register (BBRXMODESW) .....	208
Figure 4-169 Format of Mode Switch Status Register (BBMSSTATE) .....	209
Figure 4-170 Format of Mode Switch Frame Control Register (BBMCON).....	210
Figure 4-171 Format of FSKCCA Level Threshold Setting Register (BBFSKCCAETH).....	211
Figure 4-172 Format of FSK Reception Level Threshold Setting Register (BBFSKLVLVTH) .....	212
Figure 4-173 Format of FSKPHR Reception Register (BBFSKPHRRX) .....	213
Figure 4-174 Format of OFDM Control Register (BBOFDMCON) .....	214
Figure 4-175 Format of OFDMPHR Transmission Register 0 (BBOFDMPHRTX0) .....	215
Figure 4-176 Format of OFDMPHR Transmission Register 1 (BBOFDMPHRTX1) .....	216
Figure 4-177 Format of OFDMPHRACK Reply Register 0 (BBOFDMPHRACK0) .....	217
Figure 4-178 Format of OFDMPHRACK Reply Register 1 (BBOFDMPHRACK1) .....	218
Figure 4-179 Format of OFDMPHR Reception Register 0 (BBOFDMPHRRX0) .....	219
Figure 4-180 Format of OFDMPHR Reception Register 1 (BBOFDMPHRRX1) .....	220

Figure 4-181 Format of OFDMPHR Reception Register 2 (BBOFDMPHRRX2) (1/2)	221
Figure 4-182 Format of OFDMPHR Reception Register 2 (BBOFDMPHRRX2) (2/2)	222
Figure 4-183 Format of OFDMCCA Level Threshold Setting Register (BBOFDMCCAETH)	223
Figure 4-184 Format of OFDM Reception Level Threshold Setting Register (BBOFDMLVLVTH)	224
Figure 4-185 Format of Port Direction Register 0 (GPIODIR0)	225
Figure 4-186 Format of Port Direction Register 1 (GPIODIR1)	226
Figure 4-187 Format of Port Data Register 0 (GPIODATA0) (1/2)	227
Figure 4-188 Format of Port Data Register 0 (GPIODATA0) (2/2)	228
Figure 4-189 Format of Port Data Register 1 (GPIODATA1)	229
Figure 4-190 Format of Port Output Driving Capability Switching Register 0 (GPIODRV0)	230
Figure 4-191 Format of Port Output Driving Capability Switching Register 1 (GPIODRV1)	231
Figure 4-192 Format of Pull-Up/Pull-Down Selection Register 0 (PULLSEL0) (1/2)	232
Figure 4-193 Format of Pull-Up/Pull-Down Selection Register 0 (PULLSEL0) (2/2)	233
Figure 4-194 Format of Pull-Up/Pull-Down Selection Register 1 (PULLSEL1) (1/2)	234
Figure 4-195 Format of Pull-Up/Pull-Down Selection Register 1 (PULLSEL1) (2/2)	235
Figure 4-196 Format of Pull-Up/Pull-Down Selection Register 2 (PULLSEL2) (1/2)	236
Figure 4-197 Format of Pull-Up/Pull-Down Selection Register 2 (PULLSEL2) (2/2)	237
Figure 4-198 Format of Pull-Up/Pull-Down Selection Register 3 (PULLSEL3) (1/2)	238
Figure 4-199 Format of Pull-Up/Pull-Down Selection Register 3 (PULLSEL3) (2/2)	239
Figure 4-200 Format of GPIO Function Selection Register 0 (BBGPIOFUNCSEL0)	240
Figure 4-201 Format of GPIO Function Selection Register 1 (BBGPIOFUNCSEL1)	241
Figure 4-202 Format of GPIO Function Selection Register 2 (BBGPIOFUNCSEL2)	242
Figure 4-203 Format of GPIO Function Selection Register 3 (BBGPIOFUNCSEL3)	243
Figure 4-204 Format of GPIO Function Selection Register 4 (BBGPIOFUNCSEL4)	244
Figure 4-205 Format of GPIO Function Selection Register 5 (BBGPIOFUNCSEL5)	245
Figure 4-206 Format of GPIO Function Selection Register 6 (BBGPIOFUNCSEL6)	246
Figure 4-207 Format of RX-State OSC Setting Register (BBRXOSC)	247
Figure 4-208 Format of NEWMODE Transmission Control Register (BBNMTXCON)	249
Figure 4-209 Format of NEWMODE Transmission SX Shift Frequency Setting Register (BBNMTXSXSFTFREQ)	250
Figure 4-210 Format of NEWMODE Transmission Frequency Setting Register (BBNMTXFREQ)	251
Figure 4-211 Format of NEWMODE Transmission FSK Control Register 0 (BBNMTXFSKCON0)	252
Figure 4-212 Format of NEWMODE Transmission FSK Control Register 1 (BBNMTXFSKCON1) (1/2)	253
Figure 4-213 Format of NEWMODE Transmission FSK Control Register 1 (BBNMTXFSKCON1) (2/2)	254
Figure 4-214 Format of NEWMODE Reception Control Register 0 (BBNMRXCON0)	255
Figure 4-215 Format of NEWMODE Reception Control Register 1 (BBNMRXCON1)	256
Figure 4-216 Format of NEWMODE Reception Control Register 2 (BBNMRXCON2) (1/2)	257
Figure 4-217 Format of NEWMODE Reception Control Register 2 (BBNMRXCON2) (2/2)	258
Figure 4-218 Format of NEWMODE Reception Frequency Setting Register (BBNMRXBBFREQ)	259
Figure 4-219 Format of NEWMODE Reception FSK Control Register 0 (BBNMRXFSKCON0)	260
Figure 4-220 Format of NEWMODE Reception FSK Control Register 1 (BBNMRXFSKCON1) (1/2)	261
Figure 4-221 Format of NEWMODE Reception FSK Control Register 1 (BBNMRXFSKCON1) (2/2)	262
Figure 4-222 Format of NEWMODE Reception OFDM Control Register (BBNMRXOFDMCON) (1/2)	263
Figure 4-223 Format of NEWMODE Reception OFDM Control Register (BBNMRXOFDMCON) (2/2)	264
Figure 4-224 Format of Preamble Length Setting Register (BBPAMBL)	265
Figure 4-225 Format of Preamble Setting Register (BBPABL)	266

Figure 4-226 Format of TXSFD Setting Register (BBTXSFD) .....267

Figure 4-227 Format of TXSFD Setting Register 2 (BBTXSFD2) .....268

Figure 4-228 Format of TXSFD Setting Register 3 (BBTXSFD3) .....269

Figure 4-229 Format of TXSFD Setting Register 4 (BBTXSFD4) .....270

Figure 4-230 Format of SHR Control Register (BBSHRCON) .....271

Figure 4-231 Format of NEWMODE Transmission FSK Preamble Length Setting Register (BBMSPAMBL).....272

Figure 4-232 Format of Version Code Read Control Register (VERCNT) .....273

Figure 4-233 Procedure for Reading the Version Registers (VERR0 to VERR7) .....274

Figure 4-234 Format of Version Registers (VERR0 to VERR7) .....274

Figure 4-235 Format of RXSFD Setting Register 2 (BBRXSFD2) .....276

Figure 4-236 Format of RXSFD Setting Register (BBRXSFD) .....277

Figure 4-237 Format of RXSFD Setting Register 4 (BBRXSFD4) .....278

Figure 4-238 Format of RXSFD Setting Register 3 (BBRXSFD3) .....279

## Tables

Table 4-1 Register Map .....29

Table 4-2 Data Rate Setting .....70

Table 4-3 Settings of NEWMODE Transmit Registers .....248

# 1. Overview

The R9A06G062GNP delivers Sub-GHz wireless communication with OFDM and FSK modulations compliant with IEEE 802.15.4-2020 and Wi-SUN FAN1.1 profile; OFDM modulation provides high speed and robust communication for IoT devices, while FSK modulation ensures compatibility with the conventional FAN1.0 profile, making the R9A06G062GNP an essential product for IoT networks.

The R9A06G062GNP is ideal for wireless communication applications in a wide range of IoT devices including smart meters and sensor networks within the 863MHz to 928MHz band.

## 1.1 Block Diagram

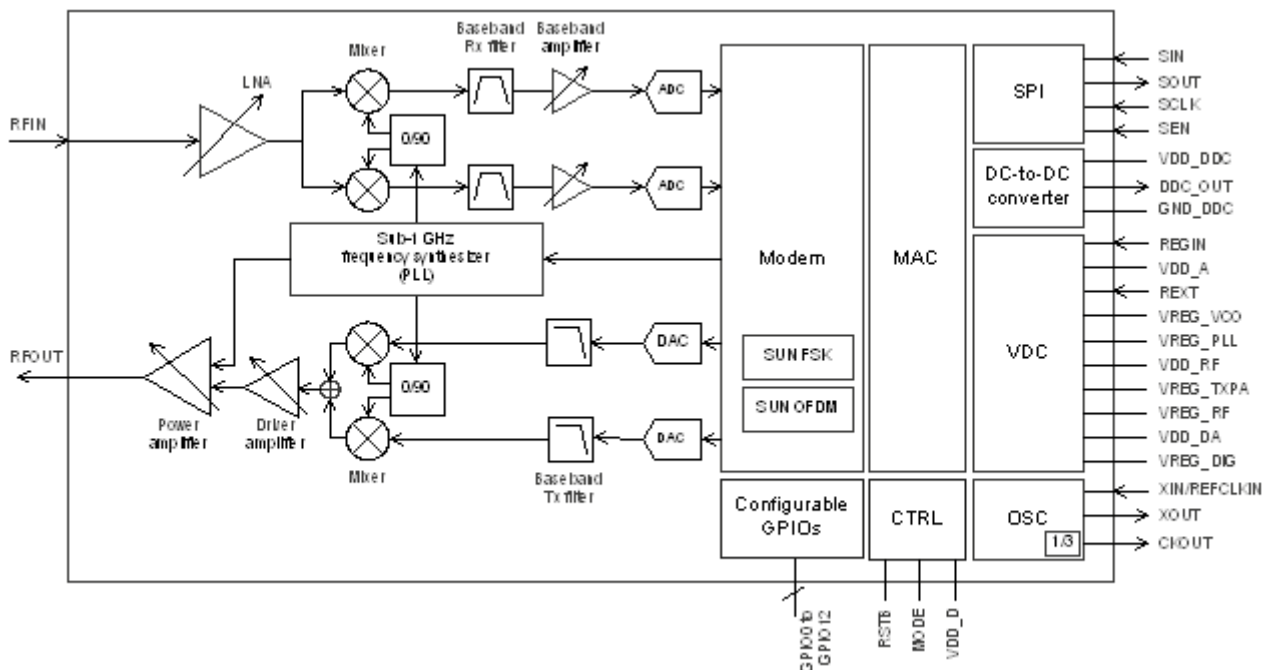

Figure 1-1 Block diagram

## 2. Pin Information

### 2.1 Pin Assignments

40-pin plastic HVQFN (6 × 6 mm, 0.5-mm pitch, NiPdAu substrate)

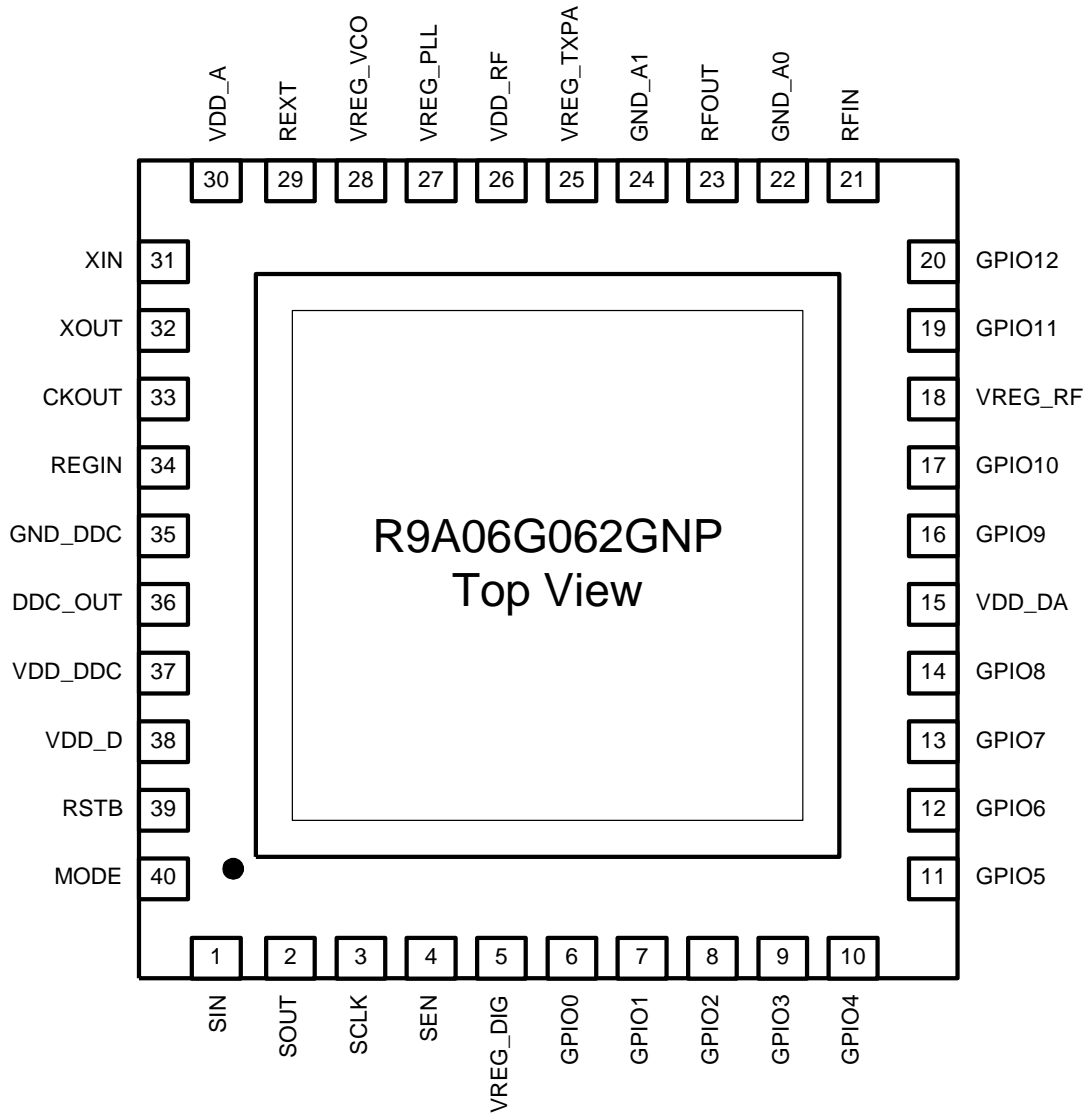

Figure 2-1 Pin Assignments – Top View

## 2.2 Pin Descriptions

Pin Number	Pin Name	I/O	A/D	Description
1	SIN	I	D	Serial input
2	SOUT	O	D	Serial output
3	SCLK	I	D	Serial clock
4	SEN	I	D	Serial enable
5	VREG_DIG	O	A	Internally regulated analog 1.1-V supply output voltage for digital circuits
6	GPIO0	I/O	D	General-purpose digital I/O 0
7	GPIO1	I/O	D	General-purpose digital I/O 1
8	GPIO2	I/O	D	General-purpose digital I/O 2
9	GPIO3	I/O	D	General-purpose digital I/O 3
10	GPIO4	I/O	D	General-purpose digital I/O 4
11	GPIO5	I/O	D	General-purpose digital I/O 5
12	GPIO6	I/O	D	General-purpose digital I/O 6
13	GPIO7	I/O	D	General-purpose digital I/O 7
14	GPIO8	I/O	D	General-purpose digital I/O 8
15	VDD_DA	I	A	3.3-V power supply voltage for the digital and analog circuits
16	GPIO9	I/O	D	General-purpose digital I/O 9
17	GPIO10	I/O	D	General-purpose digital I/O 10
18	VREG_RF	O	A	Internally regulated analog 1.1-V supply output voltage for RF section
19	GPIO11	I/O	D	General-purpose digital I/O 11
20	GPIO12	I/O	D	General-purpose digital I/O 12
21	RFIN	I	A	Rx input
22	GND_A0	I	A	Analog ground
23	RFOUT	O	A	Tx output
24	GND_A1	I	A	Analog ground
25	VREG_TXPA	O	A	Internally regulated analog 1.1-V supply output voltage for the power amplifier (PA)
26	VDD_RF	I	A	3.3-V RF power supply voltage
27	VREG_PLL	O	A	Internally regulated analog 1.1-V supply output voltage for PLL
28	VREG_VCO	O	A	Internally regulated analog 1.1-V supply output voltage for VCO
29	REXT	I	A	External reference resistor connection port

30	VDD_A	I	A	3.3-V power supply voltage for the analog circuits
31	XIN	I	A	Crystal oscillator input
32	XOUT	I/O	A	Crystal oscillator output
33	CKOUT	O	A	Clock output (16 MHz)
34	REGIN	I	A	1.4- to 1.8-V DDC_OUT voltage input
35	GND_DDC	I	A	DC-to-DC converter ground
36	DDC_OUT	O	A	1.4- to 1.8-V DC-to-DC converter output voltage
37	VDD_DDC	I	A	3.3-V DC-to-DC converter power supply voltage
38	VDD_D	I	A	3.3-V power supply voltage for the digital circuits
39	RSTB	I	D	Reset-bar input (active-low)
40	MODE	I	D	Mode switch (always low)
	EPAD			Exposed Pad. Connect the exposed pad to the ground.



## 3. Specifications

### 3.1 Absolute Maximum Ratings

The listed values are AC ratings. Applying a DC voltage on the RFIN or RFOUT pin is prohibited.

**Caution:** Product quality may suffer if the absolute maximum rating is exceeded even momentarily for any parameter. That is, the absolute maximum ratings are rated values at which the product is on the verge of suffering physical damage, and therefore the product must be used under conditions that ensure that the absolute maximum ratings are not exceeded.

Item	Symbol	Min.	Typ.	Max.	Unit	Condition
Power supply voltage	VDD	-0.5		3.8	V	VDD_A, VDD_D, VDD_AD, VDD_RF, VDD_DDC
Analog input voltage	V <sub>REGIN</sub>	-0.3		2.8	V	REGIN
Analog output voltage	V <sub>DDCOUT</sub>	-0.3		3.8	V	DDCOUT
	V <sub>REGOUT</sub>	-0.3		1.25	V	VREG_DIG, VREG_RF, VREG_PLL, VREG_VCO
	V <sub>REGRFO</sub>	-0.3		3.8	V	VREG_TXPA
RF input level	Rfin			16	dBm	RFIN
Voltage on the digital pins	Vd	-0.3		3.8	V	
Voltage on the analog pins	Va	-0.3		1.25	V	
Operating ambient temperature	Ta	-40	25	85	°C	
Storage temperature	Tstg	-65	25	150	°C	
Characteristics of electro-static discharge (ESD)	Human-body model (HBM)	-2000		2000	V	
	Charged device model (CDM)	-500		500	V	

### 3.2 Recommended Operating Conditions

Item	Symbol	Condition	Min.	Typ.	Max.	Unit
Power supply voltage	Vdd		2.7	3.3	3.6	V
Crystal resonator/oscillator oscillation frequency	Frefclk			48		MHz
Operating frequency	Frf		863		928	MHz
RFIN pin (input impedance)	Zin			50		Ω
RFOUT pin (output impedance)	Zout			50		Ω

### 3.3 Specifications of the Crystal Resonator

Item	Symbol	Condition	Min.	Typ.	Max.	Unit
Frequency	F_xtal			48		MHz
Equivalent series resistance (ESR)	ESR_xtal			20	80	$\Omega$
Load capacitance (CL)	CL_xtal		5		9	pF

### 3.4 DC Characteristics

#### 3.4.1 Digital input/output pins

VDD = 3.3 V, 25°C

Parameter	Symbol	Condition	Minimum	Typical	Maximum	Unit
High-level input voltage	V <sub>IHRF</sub>	RSTB, SIN, SCLK, SEN, GPIO0 to GPIO12	2.4		VDD	V
Low-level input voltage	V <sub>ILRF</sub>	RSTB, MODE, SIN, SCLK, SEN, GPIO0 to GPIO12	0		0.1 × VDD	V
High-level output voltage	V <sub>OHRF</sub>	I <sub>oh</sub> = 0 mA, SOUT, GPIO0 to GPIO12	VDD - 0.1		VDD	V
Low-level output voltage	V <sub>OLRF</sub>	I <sub>ol</sub> = 0 mA, SOUT, GPIO0 to GPIO12	0		0.1	V
High-level output current	I <sub>OHRF</sub>	V <sub>OHRF</sub> = VDD - 0.4 V, SOUT, GPIO0 to GPIO12			-4	mA
Low-level output current	I <sub>OLRF</sub>	V <sub>OLRF</sub> = 0.4 V, SOUT, GPIO0 to GPIO12			+4	mA
High-level input leakage current	I <sub>LIHRF1</sub>	V <sub>in</sub> = VDD, SIN, SCLK, SEN, GPIO0 to GPIO12, RSTB			200	$\mu$ A
Low-level input leakage current 1	I <sub>LILRF1</sub>	V <sub>in</sub> = GND, SIN, SCLK, SEN, GPIO0 to GPIO12			-200	$\mu$ A
High-level input leakage current 2 (with no pulling-up)	I <sub>LIHRF2</sub>	V <sub>in</sub> = VDD, SIN, SCLK, SEN, GPIO0 to GPIO12			10	$\mu$ A
Low-level input leakage current 2 (with no pulling-up)	I <sub>LILRF2</sub>	V <sub>in</sub> = GND, SIN, SCLK, SEN, GPIO0 to GPIO12			-10	$\mu$ A

## 3.5 AC Characteristics

### 3.5.1 Serial peripheral interface (SPI)

VDD = 3.3 V, 25°C

Item	Symbol	Condition	Min.	Typ.	Max.	Unit
SCLK cycle time	$t_{\text{scyc}}$		41.67			ns
SCLK high-level width	$t_{\text{sch}}$		18.5			ns
SCLK low-level width	$t_{\text{scl}}$		18.5			ns
SIN setup time	$t_{\text{sisu}}$		15			ns
SIN hold time	$t_{\text{sihd}}$		15			ns
SOUT output delay time	$t_{\text{sody}}$				14.8	ns
SEN setup time	$t_{\text{sesu}}$		33.3			ns
SEN hold time	$t_{\text{sehd}}$		200			ns

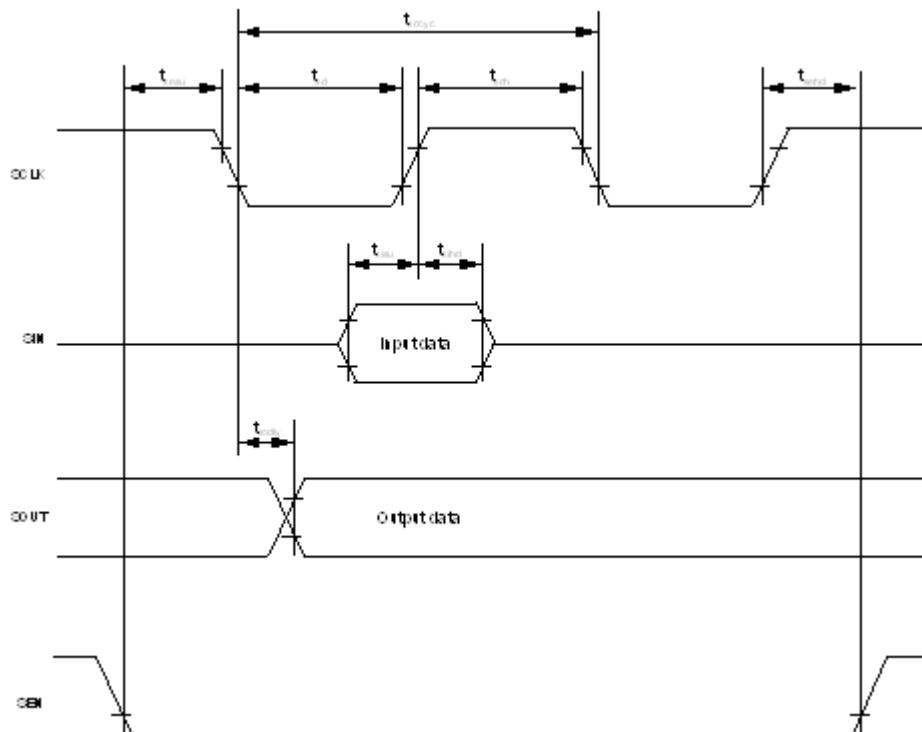

### 3.6 Characteristics of the Power Supply Current

Data rate = 100 kbps, 2-FSK, modulation index = 1.0, frequency = 920.6 MHz, VDD = 3.3 V, 25°C

Item	Condition	Min.	Typ.	Max.	Unit
SUN-FSK transmission supply current	+15.0 dBm		62		mA
	+10.0 dBm		41		
	+8.0 dBm		36		
	+0.0 dBm		23		

Data rate = 100 kbps (MCS2), band width = 400 kHz (option 3), frequency = 920.6 MHz, VDD = 3.3 V, 25°C

Item	Condition	Min.	Typ.	Max.	Unit
SUN-OFDM transmission supply current	+10.0 dBm		68.0		mA

Data rate = 100 kbps, 2-FSK, modulation index = 1.0, frequency = 920.6 MHz, VDD = 3.3 V, 25°C

Item	Condition	Min.	Typ.	Max.	Unit
SUN-FSK reception supply current	RF input at reception: -95 dBm		16.7		mA
	No RF input while waiting for reception		16.8		

Data rate = 100 kbps (MCS2), band width = 400 kHz (option 3), frequency = 920.6 MHz, VDD = 3.3 V, 25°C

Item	Condition	Min.	Typ.	Max.	Unit
SUN-OFDM reception supply current	RF input at reception: -95 dBm		21.5		mA
	No RF input while waiting for reception		21.7		

VDD = 3.3 V, 25°C

Item	Condition	Min.	Typ.	Max.	Unit
SLEEP			0.5		μA
IDLE			5.5		mA

### 3.7 Characteristics of the Transceiver Reception

#### 3.7.1 Reception sensitivity for SUN FSK

Packet length = 250 bytes, packet error rate (PER) = 10%, with no forward error correction (FEC), VDD = 3.3 V, 25°C

- North America (Frequency: 920.6 MHz)

Modulation Parameter	Channel Spacing [kHz]	Data Rate [kbps]	Modulation Index	Modulation Method	Min.	Typ.	Max.	Unit
Operating mode #1a	50	10	1	2-GFSK		-116		dBm
Operating mode #1b	100	20	1	2-GFSK		-113		dBm
Operating mode #1	200	50	1	2-GFSK		-109		dBm
Operating mode #2	400	150	0.5	2-GFSK		-105		dBm
Operating mode #3	400	200	0.5	2-GFSK		-104		dBm

- Europe (Frequency: 870.6 MHz)

Modulation Parameter	Channel Spacing [kHz]	Data Rate [kbps]	Modulation Index	Modulation Method	Min.	Typ.	Max.	Unit
Operating mode #1a	50	10	1	2-GFSK		-115		dBm
Operating mode #1b	100	20	1	2-GFSK		-112		dBm
Operating mode #1	100	50	0.5	2-GFSK		-109		dBm
Operating mode #2	200	100	0.5	2-GFSK		-106		dBm
Operating mode #3	200	150	0.5	2-GFSK		-104		dBm

- Japan (Frequency: 920.6 MHz)

Modulation Parameter	Channel Spacing [kHz]	Data Rate [kbps]	Modulation Index	Modulation Method	Min.	Typ.	Max.	Unit
Operating mode #1a	50	10	1	2-GFSK		-116		dBm
Operating mode #1b	100	20	1	2-GFSK		-113		dBm
Operating mode #1	200	50	1	2-GFSK		-109		dBm
Operating mode #2	400	100	1	2-GFSK		-105		dBm
Operating mode #3	600	200	1	2-GFSK		-102		dBm

### 3.7.2 Adjacent channel rejection ratio for SUN FSK

Packet length = 250 bytes, packet error rate (PER) = 10%, with no forward error correction (FEC), VDD = 3.3 V, 25°C, desired wave input level: sensitivity specified in the standard<sup>[1]</sup> + 3 dB

- North America (Frequency: 920.6 MHz)

Modulation Parameter	Channel Spacing [kHz]	Data Rate [kbps]	Modulation Index	Modulation Method	Min. (-1ch/+1ch)	Typ. (-1ch/+1ch)	Max. (-1ch/+1ch)	Unit
Operating mode #1a	50	10	1	2-GFSK		47/47		dB
Operating mode #1b	100	20	1	2-GFSK		44/44		dB
Operating mode #1	200	50	1	2-GFSK		44/44		dB
Operating mode #2	400	150	0.5	2-GFSK		48/48		dB
Operating mode #3	400	200	0.5	2-GFSK		41/42		dB

- Europe (Frequency: 863.1 MHz)

Modulation Parameter	Channel Spacing [kHz]	Data Rate [kbps]	Modulation Index	Modulation Method	Min. (-1ch/+1ch)	Typ. (-1ch/+1ch)	Max. (-1ch/+1ch)	Unit
Operating mode #1a	50	10	1	2-GFSK		45/45		dB
Operating mode #1b	100	20	1	2-GFSK		42/42		dB
Operating mode #1	100	50	0.5	2-GFSK		38/38		dB
Operating mode #2	200	100	0.5	2-GFSK		41/40		dB
Operating mode #3	200	150	0.5	2-GFSK		34/34		dB

- Japan (Frequency: 920.6 MHz)

Modulation Parameter	Channel Spacing [kHz]	Data Rate [kbps]	Modulation Index	Modulation Method	Min. (-1ch/+1ch)	Typ. (-1ch/+1ch)	Max. (-1ch/+1ch)	Unit
Operating mode #1a	50	10	1	2-GFSK		47/47		dB
Operating mode #1b	100	20	1	2-GFSK		44/44		dB
Operating mode #1	200	50	1	2-GFSK		44/45		dB
Operating mode #2	400	100	1	2-GFSK		49/49		dB
Operating mode #3	600	200	1	2-GFSK		48/49		dB

### 3.7.3 Alternate channel rejection ratio for SUN FSK

Packet length = 250 bytes, packet error rate (PER) = 10%, with no forward error correction (FEC), VDD = 3.3 V, 25°C, desired wave input level: sensitivity specified in the standard<sup>[1]</sup> + 3 dB

- North America (Frequency: 920.6 MHz)

Modulation Parameter	Channel Spacing [kHz]	Data Rate [kbps]	Modulation Index	Modulation Method	Min. (-2ch/+2ch)	Typ. (-2ch/+2ch)	Max. (-2ch/+2ch)	Unit
Operating mode #1a	50	10	1	2-GFSK		48/48		dB
Operating mode #1b	100	20	1	2-GFSK		49/49		dB
Operating mode #1	200	50	1	2-GFSK		53/53		dB
Operating mode #2	400	150	0.5	2-GFSK		57/58		dB
Operating mode #3	400	200	0.5	2-GFSK		55/55		dB

- Europe (Frequency: 863.1 MHz)

Modulation Parameter	Channel Spacing [kHz]	Data Rate [kbps]	Modulation Index	Modulation Method	Min. (-2ch/+2ch)	Typ. (-2ch/+2ch)	Max. (-2ch/+2ch)	Unit
Operating mode #1a	50	10	1	2-GFSK		45/45		dB
Operating mode #1b	100	20	1	2-GFSK		45/46		dB
Operating mode #1	100	50	0.5	2-GFSK		44/44		dB
Operating mode #2	200	100	0.5	2-GFSK		51/51		dB
Operating mode #3	200	150	0.5	2-GFSK		46/38		dB

- Japan (Frequency: 920.6 MHz)

Modulation Parameter	Channel Spacing [kHz]	Data Rate [kbps]	Modulation Index	Modulation Method	Min. (-2ch/+2ch)	Typ. (-2ch/+2ch)	Max. (-2ch/+2ch)	Unit
Operating mode #1a	50	10	1	2-GFSK		48/48		dB
Operating mode #1b	100	20	1	2-GFSK		49/49		dB
Operating mode #1	200	50	1	2-GFSK		53/53		dB
Operating mode #2	400	100	1	2-GFSK		59/60		dB
Operating mode #3	600	200	1	2-GFSK		47/58		dB

### 3.7.4 Characteristics of the SUN-FSK reception

Frequency = 920.6 MHz, 2-GFSK, 50 kbps, modulation index = 1.0, VDD = 3.3 V, 25°C

Item	Condition	Min.	Typ.	Max.	Unit
Maximum RF input voltage	Packet length = 250 bytes Packet error rate (PER) = 10%			+10	dBm
RSSI range		-108		-5	dBm
RSSI resolution			1		dB
RSSI precision		-5		5	dB
Frequency deviation tolerance	Sensitivity degradation: 1 dB	-10		10	ppm
Modulation quality tolerance (fdev_error)	Sensitivity degradation: 3 dB	-20		20	%

### 3.7.5 Reception sensitivity for SUN OFDM

- North America and Japan

Frequency = 920.6 MHz, packet length = 250 bytes, packet error rate (PER) = 10%, VDD = 3.3 V, 25°C, typical values

Modulation Parameter	Option 1	Option 2	Option 3	Option 4	Unit
MCS0 (BPSK 1/2 w/ 4xfreq.rep)	-113	-116	-118	-119	dBm
MCS1 (BPSK 1/2 w/ 2xfreq.rep)	-110	-114	-117	-118	
MCS2 (QPSK 1/2 w/ 2xfreq.rep)	-107	-110	-114	-112	
MCS3 (QPSK 1/2)	-104	-107	-111	-111	
MCS4 (QPSK 3/4)	-102	-104	-108	-109	
MCS5 (16QAM 1/2)	-99	-101	-105	-106	
MCS6 (16QAM 3/4)	-95	-98	-101	-103	

### 3.7.6 Adjacent channel rejection ratio for SUN OFDM

- North America and Japan

Frequency = 920.6 MHz, packet length = 250 bytes, packet error rate (PER) = 10%, VDD = 3.3 V, 25°C, typical values, desired wave input level: sensitivity specified in the standard<sup>[1]</sup> + 3 dB

Parameter	Option 1	Option 2	Option 3	Option 4	Unit
	-1.2/+1.2 MHz	-0.8/+0.8 MHz	-0.4/+0.4 MHz	-0.2/+0.2 MHz	
MCS0 (BPSK 1/2 w/ 4xfreq.rep)	33/31	44/48	49/45	34/31	dB
MCS1 (BPSK 1/2 w/ 2xfreq.rep)	33/31	43/53	46/44	34/31	
MCS2 (QPSK 1/2 w/ 2xfreq.rep)	34/31	40/52	47/45	33/31	
MCS3 (QPSK 1/2)	33/31	37/49	42/45	33/31	
MCS4 (QPSK 3/4)	31/30	33/46	46/45	33/31	
MCS5 (16QAM 1/2)	28/28	31/44	44/42	32/31	
MCS6 (16QAM 3/4)	23/23	28/41	41/39	31/30	

### 3.7.7 Alternate channel rejection ratio for SUN OFDM

- North America and Japan

Frequency = 920.6 MHz, packet length = 250 bytes, packet error rate (PER) = 10%, VDD = 3.3 V, 25°C, typical values, desired wave input level: sensitivity specified in the standard<sup>[1]</sup> + 3 dB

Parameter	Option 1	Option 2	Option 3	Option 4	Unit
	-2.4/+2.4 MHz	-1.6/+1.6 MHz	-0.8/+0.8 MHz	-0.4/+0.4 MHz	
MCS0 (BPSK 1/2 w/ 4xfreq.rep)	50/48	54/58	60/63	49/49	dB
MCS1 (BPSK 1/2 w/ 2xfreq.rep)	47/46	52/62	60/63	50/50	
MCS2 (QPSK 1/2 w/ 2xfreq.rep)	54/55	54/58	59/59	48/48	
MCS3 (QPSK 1/2)	52/53	52/52	56/56	47/48	
MCS4 (QPSK 3/4)	47/51	51/51	53/53	47/48	
MCS5 (16QAM 1/2)	46/48	48/50	50/50	47/48	
MCS6 (16QAM 3/4)	42/44	45/47	47/47	46/46	



### 3.7.8 Co-channel rejection ratio for SUN OFDM

- North America and Japan

Frequency = 920.6 MHz, packet length = 250 bytes, packet error rate (PER) = 10%, VDD = 3.3 V, 25°C, typical values, desired wave input level: sensitivity specified in the standard<sup>[1]</sup> + 3 dB

Parameter	Option 1	Option 2	Option 3	Option 4	Unit
	±0 kHz	±0 kHz	±0 kHz	±0 kHz	
MCS0 (BPSK 1/2 w/ 4xfreq.rep)	4	3	2	-1	dB
MCS1 (BPSK 1/2 w/ 2xfreq.rep)	2	2	1	-1	
MCS2 (QPSK 1/2 w/ 2xfreq.rep)	-2	-2	-3	-9	
MCS3 (QPSK 1/2)	-5	-5	-4	-7	
MCS4 (QPSK 3/4)	-7	-7	-7	-8	
MCS5 (16QAM 1/2)	-10	-12	-10	-11	
MCS6 (16QAM 3/4)	-13	-13	-13	-13	

### 3.7.9 Characteristics of the SUN-OFDM reception

Frequency = 920.6 MHz, option 1, MCS6, VDD = 3.3 V, 25°C

Item	Condition	Min.	Typ.	Max.	Unit
Maximum RF input power	Packet length = 250 bytes Packet error rate (PER): 10%		+5		dBm
RSSI range		-97		-5	dBm
RSSI resolution			1		dB
RSSI accuracy		-5		5	dB
Frequency deviation tolerance	Sensibility degradation: 1 dB	-20		20	ppm
Modulation quality tolerance (degradation of sensitivity)	Error vector magnitude (EVM): IEEE802.15.4-2020 <sup>[1]</sup>		2		dB

### 3.8 Characteristics of Transceiver Transmission

#### 3.8.1 Characteristics of the SUN-FSK transmission

Frequency = 920.6 MHz, VDD = 3.3 V, 25°C

Item		Condition	Min.	Typ.	Max.	Unit
Maximum transmission output power		CW		+15.0		dBm
Minimum transmission output power		CW		-15.0		dBm
Adjustable step size for transmission output power		CW		1.0		dB
Deviation of the output power depending on the temperature		Ta: -40°C to +85°C			2	dB
Harmonics	Second	Output power level = +15 dBm		-41.3		dBm
	Third			-41.3		dBm
	Fourth to seventh			-41.3		dBm
Frequency deviation error		Output power level = +15 dBm			30	%
Maximum zero crossing offset		Output power level = +15 dBm	-12.5		12.5	%
Transmission frequency deviation		Output power level = +15 dBm	-20		20	ppm
Adjacent channel leakage ratio		Output power level = +15 dBm	50 kbps, MI = 0.5		-49	dB
			50 kbps, MI = 1.0		-50	
			100 kbps, MI = 0.5		-50	
			100 kbps, MI = 1.0		-47	

### 3.8.2 Characteristics of the SUN-OFDM transmission

Frequency = 920.6 MHz, option 1, VDD = 3.3 V, 25°C

Item		Condition	Min.	Typ.	Max.	Unit
Maximum transmission output power		BPSK, R = 1/2, (MCS0,1), EVM = -10 dB		11		dBm
		QPSK, R = 1/2, (MCS2,3), EVM = -13 dB		10		
		QPSK, R = 3/4, (MCS4), EVM = -13 dB		10		
		16QAM, R = 1/2, (MCS5), EVM = -19 dB		9		
		16QAM, R = 3/4, (MCS6), EVM = -19 dB		9		
Minimum transmission output power		BPSK, R = 1/2, (MCS0,1), EVM = -10 dB		-19		dBm
		QPSK, R = 1/2, (MCS2,3), EVM = -13 dB		-19		
		QPSK, R = 3/4, (MCS4), EVM = -13 dB		-19		
		16QAM, R = 1/2, (MCS5), EVM = -19 dB		-19		
		16QAM, R = 3/4, (MCS6), EVM = -19 dB		-19		
Adjustable step size for transmission output power				1.0		dB
Deviation of the output power depending on the temperature		Ta: -40°C to +85°C		2		dB
Harmonic	Second harmonic	The transmission output power is at its maximum.		-41.3		dBm
	Third harmonic			-41.3		dBm
	Fourth to seventh harmonic			-41.3		dBm
Adjacent channel leakage ratio		BPSK, R = 1/2 (MCS0,1), +11 dBm output		-29		dB
		QPSK, R = 1/2 (MCS2,3), +10 dBm output		-31		
		QPSK, R = 3/4 (MCS4), +10 dBm output		-31		
		16QAM, R = 1/2 (MCS5), +9 dBm output		-33		
		16QAM, R = 3/4 (MCS6), +9 dBm output		-33		

### 3.9 Specifications of the Data Rate

- SUN FSK

Data Rate [kbps]	Modulation Method	Modulation Index	Descriptions
10	2-GFSK	1.0	
20	2-GFSK	1.0	
50	2-GFSK	0.5	
50	2-GFSK	1.0	
100	2-GFSK	0.5	
100	2-GFSK	1.0	
150	2-GFSK	0.5	
200	2-GFSK	0.5	
200	2-GFSK	1.0	

- SUN OFDM

Parameter	Option 1 Band Width: 1200 kHz	Option 2 Band Width: 800 kHz	Option 3 Band Width: 400 kHz	Option 4 Band Width: 200 kHz	Unit	Descriptions
MCS0	100	50	25	12.5	kbps	BPSK CR = 1/2 with 4xFreq. repetition
MCS1	200	100	50	25		BPSK CR = 1/2 with 2xFreq. repetition
MCS2	400	200	100	50		QPSK CR = 1/2 with 2xFreq. repetition
MCS3	800	400	200	100		QPSK CR = 1/2
MCS4	1200	600	300	150		QPSK CR = 3/4
MCS5	1600	800	400	200		16-QAM CR = 1/2
MCS6	2400	1200	600	300		16-QAM CR = 3/4

### 3.10 Compliant Standard

[1] IEEE Std 802.15.4™ -2020: IEEE Standard for Low-Rate Wireless Networks

## 4. Registers

### 4.1 Register Map

Table 4-1 Register Map

Address	Abbreviation	Attribute	Description
0000H	BBRFCON	R/W	RF start register
0001H	BBTXRXRST	R/W	Transmission and reception reset register
0002H	BBTXRXMODE0	R/W	Transmission and reception mode register 0
0003H	BBTXRXMODE1	R/W	Transmission and reception mode register 1
0004H	BBRXIDLE	R/W	RXIDLE mode register
0005H	BBRXMODE	R/W	High-speed reception switching mode register
0006H	BBEACKMODE	R/W	Enhanced ACK mode register
0007H	BBTXRXST0	R/W	Transmission and reception status register 0
0009H	BBTXRXMODE2	R/W	Transmission and reception mode register 2
000AH	BBTXRXMODE3	R/W	Transmission and reception mode register 3
000BH	BBTXRXST1	R	Transmission and reception status register 1
000CH	BBTXRXCON	R/W	Transmission and reception control register
000DH	BBCSMACON0	R/W	CSMA control register 0
0010H	BBTXRXST2	R/W	Transmission and reception status register 2
0011H	BBTXRXMODE4	R/W	Transmission and reception mode register 4
0012H	BBCSMACON1	R/W	CSMA control register 1
0013H	BBCSMACON2	R/W	CSMA control register 2
0015H, 0014H	BBPANID0	R/W	PAN identifier register 0
0017H, 0016H	BBSHORTAD0	R/W	Short address register 0
0019H, 0018H	BBEXTENDAD00	R/W	Extended address registers 0 [Bits 15 to 0]
001BH, 001AH	BBEXTENDAD01	R/W	Extended address registers 0 [Bits 31 to 16]
001DH, 001CH	BBEXTENDAD02	R/W	Extended address registers 0 [Bits 47 to 32]
001FH, 001EH	BBEXTENDAD03	R/W	Extended address registers 0 [Bits 63 to 48]
0021H, 0020H	BBTIMEREAD0	R	Timer read registers 0
0023H, 0022H	BBTIMEREAD1	R	Timer read registers 1

0025H, 0024H	BBTCOMP0REG0	R/W	Timer comparison registers 0 index 0
0027H, 0026H	BBTCOMP0REG1	R/W	Timer comparison registers 1 index 0
0029H, 0028H	BBTCOMP1REG0	R/W	Timer comparison registers 0 index 1
002BH, 002AH	BBTCOMP1REG1	R/W	Timer comparison registers 1 index 1
002DH, 002CH	BBTCOMP2REG0	R/W	Timer comparison registers 0 index 2
002FH, 002EH	BBTCOMP2REG1	R/W	Timer comparison registers 1 index 2
0031H, 0030H	BBTSTAMP0	R	Timestamp registers 0
0033H, 0032H	BBTSTAMP1	R	Timestamp registers 1
0034H	BBTIMECON	R/W	Timer control register
0035H	BBBOFFPROD	R/W	Backoff period register
0036H	BBPARAMRATE	R/W	Timing parameter data rate setting register
0039H, 0038H	BBEXTRATE	R/W	Extended data rate setting register
003EH	BBCSMACON3	R/W	CSMA control register 3
003FH	BBCAL	R/W	Calibration register
0047H, 0046H	ACKRTNTIM	R/W	ACK reply time setting register
0049H, 0048H	AUTORCVCNT	R/W	Automatic switching to reception comparison register
004BH, 004AH	BOFFPERIOD	R/W	Backoff cycle register
004DH, 004CH	CSMAENDCOUNT	R/W	CSMA-CA end count register
004FH, 004EH	CSMASTACOUNT	R/W	CSMA-CA start count register
0066H	COMSTATE1	R	Communication status register 1
0067H	COMSTATE2	R	Communication status register 2
0068H	BBEVAREG	R/W	Evaluation control register
0069H	BBBOFFPROD2	R/W	Backoff period register 2
006FH	COMSTATE3	R	Communication status register 3
0071H, 0070H	ACKRCVWIT	R/W	ACK reception wait time setting register
0073H, 0072H	RETRNWUP	R/W	Retransmission start comparison register
00A1H, 00A0H	BBRXFLEN	R	Received frame length register
00A3H, 00A2H	BBRXCOUNT	R	Received data counter register
00A5H, 00A4H	BBTXFLEN	R/W	Transmitted frame length register
00ABH to 00A8H	BBFREQ	R/W	Frequency setting register

00ACH	BBIFSET	R/W	IF frequency setting register
00AEH, 00ADH	BBSXSFTFREQ	R/W	SX shift frequency setting register
00B3H, 00B2H	CCATIME	R/W	CCA time register
00B6H to 00B4H	BBIFOFS0	R/W	IF frequency offset setting register 0
00BAH to 00B8H	BBIFOFS1	R/W	IF frequency offset setting register 1
00BDH, 00BCH	BBTXCOUNT	R	Transmitted data counter register
00BEH	BBEXTCON0	R/W	External device control register 0
00BFH	BBEXTCON1	R/W	External device control register 1
00C1H, 00C0H	BBCTXSET	R/W	CTX set timing register
00C3H, 00C2H	BBCTXCLR	R/W	CTX clear timing register
00C5H, 00C4H	BBCPSSET	R/W	CPS set timing register
00C7H, 00C6H	BBCPSCLR	R/W	CPS clear timing register
00C9H, 00C8H	BBCSDSET	R/W	CSD set timing register
00CBH, 00CAH	BBCSDCLR	R/W	CSD clear timing register
00D3H, 00D2H	BBRCVINTCOMP	R/W	Number-of-received-byte interrupt comparison register
00D5H, 00D4H	BBBOPTOTAL	R	Backoff period total number register
00D6H	BBCCATOTAL	R	CCA total number register
00DFH	BBADFCON	R/W	Address filter extension address control register
00E1H, 00E0H	BBPANID1	R/W	PAN identifier register 1
00E3H, 00E2H	BBSHORTAD1	R/W	Short address register 1
00E5H, 00E4H	BBEXTENDAD10	R/W	Extended address registers 1 [Bits 15 to 0]
00E7H, 00E6H	BBEXTENDAD11	R/W	Extended address registers 1 [Bits 31 to 16]
00E9H, 00E8H	BBEXTENDAD12	R/W	Extended address registers 1 [Bits 47 to 32]
00EBH, 00EAH	BBEXTENDAD13	R/W	Extended address registers 1 [Bits 63 to 48]
00EDH, 00ECH	BBTIMEOUT	R/W	Reception timeout register
00F2H	BBINTOUTMODE	R/W	INTOUT mode register
00F4H	BBINT0REQ0	R	INTOUT0 interrupt source register 0
00F5H	BBINT0REQ1	R	INTOUT0 interrupt source register 1
00F6H	BBINT0REQ2	R	INTOUT0 interrupt source register 2
00F7H	BBINT0REQ3	R	INTOUT0 interrupt source register 3

00F8H	BBINT0REQ4	R	INTOUT0 interrupt source register 4
00F9H	BBINT0REQ5	R	INTOUT0 interrupt source register 5
00FAH	BBINT0REQ6	R	IINTOUT0 interrupt source register 6
00FBH	BBINT0REQ7	R	INTOUT0 interrupt source register 7
00FCH	BBINT0EN0	R/W	INTOUT0 interrupt enable register 0
00FDH	BBINT0EN1	R/W	INTOUT0 interrupt enable register 1
00FEH	BBINT0EN2	R/W	INTOUT0 interrupt enable register 2
00FFH	BBINT0EN3	R/W	INTOUT0 interrupt enable register 3
0100H	BBINT0EN4	R/W	INTOUT0 interrupt enable register 4
0101H	BBINT0EN5	R/W	INTOUT0 interrupt enable register 5
0102H	BBINT0EN6	R/W	INTOUT0 interrupt enable register 6
0103H	BBINT0EN7	R/W	INTOUT0 interrupt enable register 7
0104H	BBINT0REQEN0	R/W	INTOUT0 interrupt source enable register 0
0105H	BBINT0REQEN1	R/W	INTOUT0 interrupt source enable register 1
0106H	BBINT0REQEN2	R/W	INTOUT0 interrupt source enable register 2
0107H	BBINT0REQEN3	R/W	INTOUT0 interrupt source enable register 3
0108H	BBINT0REQEN4	R/W	INTOUT0 interrupt source enable register 4
0109H	BBINT0REQEN5	R/W	INTOUT0 interrupt source enable register 5
010AH	BBINT0REQEN6	R/W	INTOUT0 interrupt source enable register 6
010BH	BBINT0REQEN7	R/W	INTOUT0 interrupt source enable register 7
0117H, 0116H	BBTRNINTCOMP	R/W	Number-of-transmitted-byte interrupt comparison register
0118H	BBCCAMODE	R/W	CCA mode register
0119H	BBRCVMODE	R/W	Receive mode register
011BH, 011AH	BBFLCNCLMIN	R/W	Frame cancellation minimum length register
011DH, 011CH	BBFLCNCLMAX	R/W	Frame cancellation maximum length register
011EH	BBBYTEINTMODE	R/W	Number-of-byte interrupt mode register
0121H, 0120H	BBRSSIRSLT	R	RSSI result register
0123H, 0122H	BBRCPIRSLT	R	RCPI result register
0124H	BBRSSIRSLT2	R	RSSI result 2 register
0125H	BBRCPIRSLT2	R	RCPI result 2 register



0127H, 0126H	BBED1RSLT	R	ED1 result register
0129H, 0128H	BBED2RSLT	R	ED2 result register
012AH	BBED1RSLT2	R	ED1 result 2 register
012BH	BBED2RSLT2	R	ED2 result 2 register
012DH	BBCCACLRCOUNT	R/W	CCA clearance count register
012FH, 012EH	BBCCALIMIT	R/W	CCA limit setting register
0131H, 0130H	BBPASSTIME0	R/W	Comparison 0 setting excess time register 0
0133H, 0132H	BBPASSTIME1	R/W	Comparison 0 setting excess time register 1
0135H, 0134H	BBFSYNCPowRD	R	Frame synchronization power value read register
0136H	BBFSYNCPowRD2	R	Frame synchronization power value 2 read register
0139H, 0138H	BBRSSIRD	R	RSSI read register
013BH, 013AH	BBRCPIRD	R	RCPI read register
013CH	BBRSSIRD2	R	RSSI read 2 register
013DH	BBRCPIRD2	R	RCPI read 2 register
0140H	BBTRXSEL	R/W	Transmission and reception method selection register
0141H	BBRXMODEMONI	R	Reception method check register
0142H	BBRXPROHIBIT	R/W	Reception prohibition register
0143H	BBRCVCOUNTCNT	R/W	Received frame counter control register
0147H to 0144H	BBRCVCOUNT	R	Total reception counter
014BH to 0148H	BBPHRERRCOUNT	R	PHR error counter
014FH to 014CH	BBRCVOKCOUNT	R	Number-of-successful-receptions counter
0153H to 0150H	BBRCVNGCOUNT	R	Number-of-unsuccessful-receptions counter
0159H, 0158H	BBFSYNCPowRSL T	R	Frame synchronization power value result register
015AH	BBFSYNCPowRSL T2	R	Frame synchronization power value result 2 register
015EH	BBCCARATECON	R/W	CCA data rate control register
0160H	BBFSKCON0	R/W	FSK control register 0
0161H	BBFSKCON1	R/W	FSK control register 1
0162H	BBFSKCON2	R/W	FSK control register 2
0163H	BBFSKFECCON	R/W	FSKFEC control register
0165H, 0164H	BBTXMODESW	R/W	Mode switch frame transmission register

0167H, 0166H	BBRXMODESW	R	Mode switch frame reception register
0168H	BBMSSTATE	R	Mode switch status register
0169H	BBMSCON	R/W	Mode switch frame control register
016BH, 016AH	BBFSKCCAVTH	R/W	FSKCCA level threshold setting register
016DH, 016CH	BBFSKLVLVTH	R/W	FSK reception level threshold setting register
016EH	BBFSKPHRRX	R	FSKPHR reception register
0170H	BBOFDMCON	R/W	OFDM control register
0172H	BBOFDMPHRTX0	R/W	OFDMPHR transmission register 0
0173H	BBOFDMPHRTX1	R/W	OFDMPHR transmission register 1
0174H	BBOFDMPHRACK0	R/W	OFDMPHRACK reply register 0
0175H	BBOFDMPHRACK1	R/W	OFDMPHRACK reply register 1
0176H	BBOFDMPHRRX0	R	OFDMPHR reception register 0
0177H	BBOFDMPHRRX1	R	OFDMPHR reception register 1
0178H	BBOFDMPHRRX2	R	OFDMPHR reception register 2
017BH, 017AH	BBOFDMCCAETH	R/W	OFDMCCA level threshold setting register
017DH, 017CH	BBOFDMMLVLVTH	R/W	OFDM reception level threshold setting register
0190H	GPIODIR0	R/W	Port direction register 0
0191H	GPIODIR1	R/W	Port direction register 1
0192H	GPIODATA0	R/W	Port data register 0
0193H	GPIODATA1	R/W	Port data register 1
0194H	GPIODRV0	R/W	Port output driving capability switching register 0
0195H	GPIODRV1	R/W	Port output driving capability switching register 1
0198H	PULLSEL0	R/W	Pull-up/pull-down selection register 0
0199H	PULLSEL1	R/W	Pull-up/pull-down selection register 1
019AH	PULLSEL2	R/W	Pull-up/pull-down selection register 2
019BH	PULLSEL3	R/W	Pull-up/pull-down selection register 3
01A0H	BBGPIOFUNCSEL0	R/W	GPIO function selection register 0
01A1H	BBGPIOFUNCSEL1	R/W	GPIO function selection register 1
01A2H	BBGPIOFUNCSEL2	R/W	GPIO function selection register 2
01A3H	BBGPIOFUNCSEL3	R/W	GPIO function selection register 3

01A4H	BBGPIOFUNCSEL4	R/W	GPIO function selection register 4
01A5H	BBGPIOFUNCSEL5	R/W	GPIO function selection register 5
01A6H	BBGPIOFUNCSEL6	R/W	GPIO function selection register 6
01C8H	BBRXOSC	R/W	RX-state OSC setting register
01E8H	BBNMTXCON	R/W	NEWMODE transmission control register
01EBH, 01EAH	BBNMTXSXSFTFR EQ	R/W	NEWMODE Transmission SX shift frequency setting register
01EFH to 01ECH	BBNMTXFREQ	R/W	NEWMODE transmission frequency setting register
01F0H	BBNMTXFSKCON0	R/W	NEWMODE transmission FSK control register 0
01F1H	BBNMTXFSKCON1	R/W	NEWMODE transmission FSK control register 1
01F2H	BBNMRXCON0	R/W	NEWMODE reception control register 0
01F3H	BBNMRXCON1	R/W	NEWMODE reception control register 1
01F4H	BBNMRXCON2	R/W	NEWMODE reception control register 2
01F8H to 01F5H	BBNMRXBBFREQ	R/W	NEWMODE reception frequency setting register
01F9H	BBNMRXFSKCON0	R/W	NEWMODE reception FSK control register 0
01FAH	BBNMRXFSKCON1	R/W	NEWMODE reception FSK control register 1
01FBH	BBNMRXOFDMCO N	R/W	NEWMODE reception OFDM control register
0446H, 0445H	BBPAMBL	R/W	Preamble length setting register
0447H	BBPABL	R/W	Preamble setting register
044BH to 0448H	BBTXSFD	R/W	TXSFD setting register
044FH to 044CH	BBTXSFD2	R/W	TXSFD setting register 2
0453H to 0450H	BBTXSFD3	R/W	TXSFD setting register 3
0460H to 045EH, 0454H	BBTXSFD4	R/W	TXSFD setting register 4
0461H	BBSHRCON	R/W	SHR control register
0475H, 0474H	BBMSPAMBL	R/W	NEWMODE transmission FSK preamble length setting register
04DEH	VERCNT	R/W	Version code read control register
04E0H	VERR0	R	Version register 0
04E1H	VERR1	R	Version register 1
04E2H	VERR2	R	Version register 2
04E3H	VERR3	R	Version register 3

04E4H	VERR4	R	Version register 4
04E5H	VERR5	R	Version register 5
04E6H	VERR6	R	Version register 6
04E7H	VERR7	R	Version register 7
08F0H to 08F3H (*)	BBRXSFD2	R/W	RXSFD setting register 2
08F4H to 08F7H (*)	BBRXSFD	R/W	RXSFD setting register
08F8H to 08FBH (*)	BBRXSFD4	R/W	RXSFD setting register 4
08FCH to 08FFH (*)	BBRXSFD3	R/W	RXSFD setting register 3

(\*): Big endian.

## 4.2 Register Descriptions

### 4.2.1 RF start register (BBRFCON)

The RF function is enabled by setting the RF function enable bit to 1. Calibration is enabled by setting the calibration control bit to 1. Clear this bit to 0 after calibration is completed. The register access area switch bit switches the area to be allocated to addresses 0600H to 0FFFH as shown in Figure 4-2. Transition to the STANDBY state is allowed by the STANDBY transition enable bit. Set this bit to 1 to make a transition from the IDLE state to the STANDBY state. The value of this register following a reset is 01H.

**Figure 4-1 Format of RF Start Register (BBRFCON)**

Address: 0000H After reset: 01H R/W

Symbol	7	6	5	4	3	2	1	0
BBRFCON	0	0	STANDBY EN	0	REG ACCESS	CSONSET	0	RFSTART

STANDBY EN	STANDBY transition enable
0	Transition to the STANDBY state is allowed. Set this bit to 1 to move from the IDLE state to the STANDBY state.
1	

REG ACCESS	Register access area switch
0	The area allocated to addresses 0600H to 0FFFH is switched.
1	

CSONSET	Calibration control
0	Calibration is disabled.
1	Calibration is enabled.

RFSTART	RF function enable
0	RF function is disabled.
1	RF function is enabled.

**Caution** When writing to this register, set bits 7, 6, 4, and 1 to the value 0.

Figure 4-2 Areas Switched by the Register Access Area Switch Bit

Address	Register access area switch bit = 0	Register access area switch bit = 1
0 0 0 0 to 0 0 F F	Register area (no bank)	
0 1 0 0 to 0 1 F F		
0 2 0 0 to 0 2 F F		
0 3 0 0 to 0 3 F F		
0 4 0 0 to 0 4 F F		
0 5 0 0 to 0 5 F F		
0 6 0 0 to 0 6 F F	Register area (bank 0)	Register area (bank 1)
0 7 0 0 to 0 7 F F		
0 8 0 0 to 0 8 F F		Transmission/reception RAM (2 Kbytes)  Write access = Transmission RAM values Read access = Reception RAM values
0 9 0 0 to 0 9 F F		
0 A 0 0 to 0 A F F		
0 B 0 0 to 0 B F F		
0 C 0 0 to 0 C F F		
0 D 0 0 to 0 D F F		
0 E 0 0 to 0 E F F		
0 F 0 0 to 0 F F F		

### 4.2.2 Transmission and reception reset register (BBTXRXRST)

This register is used to stop the RF communications. The processes of transmission, reception, CCA, and calibration can be stopped by setting the RF communication stop bit to 1. This device enters the IDLE state after the stop. The processes of automatic ACK reply and the automatic receive switch mode function are also canceled. Note that 0 is always read from this bit. However, the values of the other registers are retained. The value of this register following a reset is 00H.

**Figure 4-3 Format of Transmission and Reception Reset Register (BBTXRXRST)**

Address: 0001H After reset: 00H R/W

Symbol	7	6	5	4	3	2	1	0
BBTXRX RST	0	0	0	0	0	0	0	RFSTOP

RFSTOP	RF communication stop
0	Even though the RF communications are enabled, nothing proceeds.
1	The RF communications are stopped. This device enters the IDLE state after the stop.

**Caution** When writing to this register, set bits 7 to 1 to the value 0.

### 4.2.3 Transmission and reception mode register 0 (BBTXRXMODE0)

This register is used to set various modes of the RF transmission and reception. The automatic ACK mode enable bit selects whether to proceed the automatic ACK reply operation after the completion of reception. The automatic receive switch mode 0 enable bit enables the automatic transition to the receive state after the completion of transition. The automatic receive switch mode 1 enable bit enables the automatic transition to the receive state after the completion of reception. Note that the ACK reply operation takes precedence over the receive operation if the automatic ACK mode enable bit is set to 1 (enabled) and the conditions for returning ACK are satisfied. The battery life extension mode, which is a condition for branching in the CSMA-CA processing, can be enabled by the battery life extension mode bit. The beacon mode bit is used to switch between the non-beacon mode and beacon mode. The intraPAN enable bit enables or disables the intraPAN bit in the received frame when the address filter is enabled. The value of this register following a reset is 00H.



Figure 4-4 Format of Transmission and Reception Mode Register 0 (BBTXRXMODE0)

Address: 0002H After reset: 00H R/W

Symbol	7	6	5	4	3	2	1	0
BBTXRX MODE0	INTRAPAN EN	BEACON	BATLIFE EXT	AUTORCV1	AUTORCV0	AUTOACK EN	0	0

INTRAPAN EN	intraPAN enable
0	intraPAN is disabled.
1	intraPAN is enabled.

BEACON	Beacon mode
0	Non-beacon mode
1	Beacon mode

BATLIFE EXT	Battery life extension mode
0	Battery life extension mode is disabled.
1	Battery life extension mode is enabled.

AUTORCV1	Automatic receive switch mode 1 enable (reception → reception)
0	Automatic switch to reception is disabled.
1	Automatic switch to reception is enabled.

AUTORCV0	Automatic receive switch mode 0 enable (transmission → reception)
0	Automatic switch to reception is disabled.
1	Automatic switch to reception is enabled.

AUTOACK EN	Automatic ACK mode enable
0	Automatic ACK reply is disabled.
1	Automatic ACK reply is enabled.

**Caution** When writing to this register, set bits 1 and 0 to the value 0.

#### 4.2.4 Transmission and reception mode register 1 (BBTXRXMODE1)

This register is used to set various modes of the RF transmission and reception. The ACK reply frame version setting enable bit switches the value of the frame version for automatic ACK reply between the version of the received frame and the value of the ACK reply frame version setting bits 0 and 1. The ACK reply frame version setting bits 0 and 1 are respectively used to set the values of bits 12 and 13 of the frame version for automatic ACK reply when the ACK reply frame version setting enable bit is set to 1. The sequence number suppress enable bit enables or disables the sequence number suppress in the received frame. While sequence number suppression is enabled by this bit, the sequence number is omitted from the ACK frame in automatic ACK reply when no sequence number is present in the received frame. The ACK receive point setting bit is used to select whether ACK reception in the ACK receive wait time is detected upon completion of the reception or upon reception of the PHR. The value of this register following a reset is C0H.

**Figure 4-5 Format of Transmission and Reception Mode Register 1 (BBTXRXMODE1)**

Address: 0003H After reset: C0H R/W

Symbol	7	6	5	4	3	2	1	0
BBTXRX MODE1	ACKRCV POINT	SQCNUM SUPEN	ACKFV1	ACKFV0	ACKFVEN	0	0	0

ACKRCV POINT	ACK receive point setting
0	ACK reception is recognized upon completion of the reception.
1	ACK reception is recognized upon reception of the PHR.

SQCNUM SUPEN	Sequence number suppress enable
0	Sequence number suppression is enabled.
1	Sequence number suppression is disabled.

ACKFV1	ACK reply frame version setting 1
0	Frame version bit 13 = 0
1	Frame version bit 13 = 1

ACKFV0	ACK reply frame version setting 0
0	Frame version bit 12 = 0
1	Frame version bit 12 = 1

ACKFVEN	ACK reply frame version setting enable
0	Value of the Frame Version field in the received frame
1	Value of the ACK reply frame version setting bits 0 and 1

**Caution** When writing to this register, set bits 2 to 0 to the value 0.

### 4.2.5 RXIDLE mode register (BBRXIDLE)

The RXIDLE mode bit is used to place this device in the RX\_IDLE state. Set this bit to 1 while the device is in the RX state. To move from the RX\_IDLE state to the RX state, clear this bit to 0. Do not make a transition from the RX\_IDLE state to the TX state or CCA state. The RF communication stop bit must not be set to 1 in the RX\_IDLE state. The value of this register following a reset is 00H.

**Figure 4-6 Format of RXIDLE Mode Register (BBRXIDLE)**

Address: 0004H After reset: 00H R/W

Symbol	7	6	5	4	3	2	1	0
BBRXIDLE	0	0	0	0	0	0	0	RXIDLE MODE

RXIDLE MODE	RXIDLE mode
0	Normal operation
1	RX_IDLE state

**Caution** When writing to this register, set bits 7 to 1 to the value 0.

### 4.2.6 High-speed reception switching mode register (BBRXMODE)

The HISPRX mode bit is used to place this device directly in the receive wait state without going through the IDLE state when reception is stopped and then the receive wait state is automatically entered.

0: RX state → Stop trigger → IDLE state → RX state

1: RX state → Stop trigger → RX state

The high-speed reception switch is effective in any of the following cases.

- Transition to the receive wait state after a frame is discarded by the address filter function
- Transition to the receive wait state after a frame is discarded due to the illegal frame length
- Transition to the receive wait state after a frame is discarded by the receive level filter function
- Transition to the receive wait state after a frame is discarded by the reception overwriting function
- Transition to the receive wait state after reception is abandoned due to the detection of a reception level error, that is, a communications error such as no signal being received during frame reception.
- Transition to the receive wait state after an HCS error (for OFDM modulation)
- Transition to the receive wait state after reception is canceled while reception is prohibited
- Transition to the receive wait state after a mode switch frame is discarded (for FSK modulation)
- Transition to the receive wait state when automatic switch to reception is enabled by automatic receive switch mode bit 1

The value of this register following a reset is 00H.

**Figure 4-7 Format of High-Speed Reception Switching Mode Register (BBRXMODE)**

Address: 0005H After reset: 00H R/W

Symbol	7	6	5	4	3	2	1	0
BBRX MODE	0	0	0	0	0	0	0	HISPRX MODE

HISPRX MODE	HISPRX mode
0	Receive state is entered via the IDLE state.
1	Receive state is directly entered without going through the IDLE state.

**Caution** When writing to this register, set bits 7 to 1 to the value 0.

### 4.2.7 Enhanced ACK mode register (BBEACKMODE)

This register is used to set the enhanced ACK mode. The value of this register following a reset is 01H.

**Figure 4-8 Format of Enhanced ACK Mode Register (BBEACKMODE)**

Address: 0006H After reset: 01H R/W

Symbol	7	6	5	4	3	2	1	0
BBEACK MODE	0	0	0	0	0	0	0	ENHACK MODE

ENHACK MODE	Enhanced ACK mode
0	Enhanced ACK mode is disabled.
1	Enhanced ACK mode is enabled.

**Caution** When writing to this register, set bits 7 to 1 to the value 0.

#### 4.2.8 Transmission and reception status register 0 (BBTXRXST0)

This register holds various information on the states of the RF transmission and reception. The CCA judge result is stored in bit 0. The CRC judge result is stored in bit 1. The CRC result corresponding to the save bank specified by the receive data save bank select bit is read from this bit. The CSMA-CA judge result is stored in bit 2. Only 0 can be written to this bit. The result of transmission and reception sequence (CSMA-CA → transmission → ACK reception → retransmission → ACK reception, and so on) is stored in the transmission and reception completion judge result bit when the sequence is completed. This device reports "Not completed" when ACK is not received even after the sequence from the transmission to the ACK reception is repeated the specified number of times. Only 0 can be written to this bit. The reception RAM bank 0 status bit and reception RAM bank 1 status bit can be used as flags of data capturing in the respective reception RAM banks 0 and 1. Each flag is automatically set to 1 upon completion of data reception in the respective RAM. After reading data from the reception RAM, clear the flag to 0 by software. Only 0 can be written to clear these flags; set to 1 when writing to the other bits of this register. A receive overrun interrupt occurs when a frame is received again and written to a reception RAM bank while the flag for the respective RAM is set to 1. The reception pending bit holds the data of the pending bit in the received ACK data upon completion of the reception of ACK data only. The reception RAM bank pointer bit is used to check which reception RAM bank has completed data reception. The bit is set to 1 after a reset. The value of the bit changes when a reception RAM bank becomes full or when frame reception is completed. The value of this register following a reset is 80H.

Figure 4-9 Format of Transmission and Reception Status Register 0 (BBTXRXST0)

Address: 0007H After reset: 80H R/W<sup>Note</sup>

Symbol	7	6	5	4	3	2	1	0
BBTXRXST0	RCVRAMST	RCVPEND	RCVBANK1	RCVBANK0	TRNRCVSQC	CSMACA	CRC	CCA
RCVRAMST		Reception RAM bank pointer						
0	Reception RAM bank 0							
1	Reception RAM bank 1							
RCVPEND		Reception pending						
0	Pending bit is not set.							
1	Pending bit is set.							
RCVBANK1		Reception RAM bank 1 status						
0	Reception is enabled.							
1	Data have been stored in the RAM.							
RCVBANK0		Reception RAM bank 0 status						
0	Reception is enabled.							
1	Data have been stored in the RAM.							
TRNRCVSQC		Transmission and reception completion judge result						
0	Completed							
1	Not completed							
CSMACA		CSMA-CA judge result						
0	Passed							
1	Failed							
CRC		CRC judge result						
0	Successful reception							
1	Unsuccessful reception							
CCA		CCA judge result						
0	The frequency channel is cleared.							
1	The frequency channel is busy.							

**Note:** Bits 7, 6, 1, and 0 are read-only.

### 4.2.9 Transmission and reception mode register 2 (BBTXRXMODE2)

This register is used to set various modes of the RF transmission and reception. The automatic CRC disable bit selects whether to add the result of automatic CRC calculation to the transmit data or send RAM data only. The frame pending setting bit sets the value of the frame pending bit in the ACK data to be returned when the first address match is detected. The information selected by this bit is included in the ACK data in automatic ACK reply. The frame pending status bit indicates whether the ACK has been returned with frame pending enabled in automatic ACK reply. This value is updated at the same time as the occurrence of an interrupt request upon completion of transmission. As the results of automatic ACK reply are retained for individual receive data save banks, the information on the frame pending in ACK reply for the save bank selected by the receive data save bank select bit is read from this bit. The enhanced ACK enable bit enables or disables the enhanced ACK reply function. The retransmission count bits are used to set the maximum number of retransmissions until ACK is received when the automatic ACK receive mode is enabled. Set a value from 0000B to 1000B. The value of this register following a reset is 30H.

**Figure 4-10 Format of Transmission and Reception Mode Register 2 (BBTXRXMODE2)**

Address: 0009H After reset: 30H R/W<sup>Note</sup>

Symbol	7	6	5	4	3	2	1	0
BBTXRX MODE2	RETRN3	RETRN2	RETRN1	RETRN0	ENHACKEN	FLMPEND ST	FLMPEND	NOCRC

RETRN3 to RETRN0	Retransmission count (A value from 0000B to 1000B is specifiable.)

ENHACKEN	Enhanced ACK enable
0	Enhanced ACK reply is disabled.
1	Enhanced ACK reply is enabled.

FLMPEND ST	Frame pending status
0	Frame pending bit is cleared.
1	Frame pending bit is set.

FLMPEND	Frame pending setting
0	Frame pending bit = 0
1	Frame pending bit = 1

NOCRC	Automatic CRC disable
0	Enabled, i.e., the result of CRC calculation is transmitted.
1	Disabled, i.e., data on the RAM are transmitted.

**Note: Bit 2 is read-only.**



#### 4.2.10 Transmission and reception mode register 3 (BBTXRXMODE3)

This register is used to set various modes of the RF transmission and reception. The address filter enable bit enables the address filter function for reception. Setting this bit to 1 enables the address filter for the first address. The PAN coordinator bit selects whether the received address matches the PAN coordinator address as an address filter condition for the first address. The receive level filter enable bit enables reception of only the input level equal to or higher than the threshold specified in the FSK reception level threshold setting register or OFDM reception level threshold setting register. The receive data save bank select bit specifies the save bank from which the data related to reception are read (except for the reception RAM data). The reception RAM overwrite enable bit controls overwriting to the reception RAM. If write access to a reception RAM is attempted while this bit is 0 and the respective reception RAM bank n status bit is 1, the reception RAM is not overwritten by the received data. If write access to a reception RAM is attempted while this enable bit is 1, the reception RAM is overwritten by the received data even when the reception RAM bank n status bit is 1. The address filter address extension bit is used to specify whether the second address is used as a condition of the address filter in addition to the first address. The address filter general mode bit selects the general mode for the address filter operation. The value of this register following a reset is 00H.

Figure 4-11 Format of Transmission and Reception Mode Register 3 (BBTXRXMODE3)

Address: 000AH After reset: 00H R/W

Symbol	7	6	5	4	3	2	1	0
BBTXRX MODE3	ADFGEN MODE	ADFEXTEN	RCVOVERW REN	RCVBANK SEL	0	LVLFILEN	PANCORD	ADRSFILEN

ADFGEN MODE	Address filter general mode
0	WiSUN mode
1	General mode

ADFEXTEN	Address filter address extension
0	PAN ID and address extension are disabled.
1	PAN ID and address extension are enabled.

RCVOVERW REN	Reception RAM overwrite enable
0	Overwriting is disabled.
1	Overwriting is enabled.

RCVBANK SEL	Receive data save bank select
0	Receive data save bank 0 is selected.
1	Receive data save bank 1 is selected.

LVLFILEN	Receive level filter enable
0	Filter is disabled.
1	Filter is enabled.

PANCORD	PAN coordinator
0	The address is not for the PAN coordinator.
1	The address is for the PAN coordinator.

ADRSFILEN	Address filter enable
0	Address filter is disabled.
1	Address filter is enabled.

**Caution** When writing to this register, set bit 3 to the value 0.

### 4.2.11 Transmission and reception status register 1 (BBTXRXST1)

The receive data save bank pointer bit indicates the bank that holds the data related to the received frame such as the frame length. The value of this register following a reset is 02H.

**Figure 4-12 Format of Transmission and Reception Status Register 1 (BBTXRXST1)**

Address: 000BH After reset: 0000001XB R

Symbol	7	6	5	4	3	2	1	0
BBTXRXST 1	0	0	0	0	0	0	RCVSTORE ST	X

RCVSTORE ST	Receive data save bank pointer
0	Receive data save bank 0
1	Receive data save bank 1

**Caution** An undefined value (X) is read from bit 0.

### 4.2.12 Transmission and reception control register (BBTXRXCON)

This register is used to control the RF transmission and reception. Setting the receive trigger bit to 1 starts warm-up of the RF circuit. Reception becomes ready in 185  $\mu$ s. Setting the transmit trigger bit to 1 starts warm-up of the RF circuit. Transmission begins in 335  $\mu$ s. Setting the CCA trigger bit to 1 starts warm-up of the RF circuit. The CCA operation begins in 185  $\mu$ s. To proceed CCA, specify a value other than 0H in the BEMIN bits. Be sure to set these bits in the IDLE state. Note that each bit is automatically cleared to 0 upon completion of the respective operation (transmission, reception, or CCA). To stop reception while it is in progress, use the RF communication stop bit. Do not stop transmission before it is completed. The automatic ACK receive mode bit selects whether to proceed the automatic ACK receive operation. The value of this register following a reset is 00H.

**Figure 4-13 Format of Transmission and Reception Control Register (BBTXRXCON)**

Address: 000CH After reset: 00H R/W<sup>Note</sup>

Symbol	7	6	5	4	3	2	1	0
BBTXRX CON	0	0	0	0	ACKRCVEN	CCATRG	TRNTRG	RCVTRG

ACKRCVEN	Automatic ACK receive mode
0	Automatic ACK receive operation is disabled.
1	Automatic ACK receive operation is enabled.

CCATRG	CCA trigger
0	Nothing proceeds.
1	CCA is started.

TRNTRG	Transmit trigger
0	Nothing proceeds.
1	Transmission is started.

RCVTRG	Receive trigger
0	Nothing proceeds.
1	Reception is started.

**Note:** Bits 2 to 0 are write-only.

**Caution** When writing to this register, set bits 7 to 4 to the value 0.

#### 4.2.13 CSMA control register 0 (BBCSMACON0)

This register is used to control the CSMA-CA operation. Setting the automatic CSMA-CA start bit to 1 starts the CSMA-CA operation. Be sure to set this bit in the IDLE state. Note that this bit is automatically cleared to 0 upon completion of the CSMA-CA operation. This bit cannot be cleared by writing 0 to it. To stop the CSMA-CA operation while it is in progress, use the RF communication stop bit. Setting the transmission-after-automatic-CSMA-CA bit to 1 automatically starts transmission when the frequency channel is cleared in accordance with the CCA judge result after the completion of the CSMA-CA operation. Setting the reception-during-CSMA-CA enable bit to 1 enables reception during the wait time in the CCA operation in the CSMA-CA operation. Counting of the backoff period stops while a frame is being received. The unicast frame bit is used to set the unicast frame value. The function of this bit is enabled by setting the unicast frame enable bit to 1. The wait time until transmission after CCA can be minimized by setting the transmission-after-automatic-CSMA-CA mode bit to 1. The value of this register following a reset is 00H.

Figure 4-14 Format of CSMA Control Register 0 (BBCSMACON0)

Address: 000DH After reset: 00H R/W<sup>Note</sup>

Symbol	7	6	5	4	3	2	1	0
BBCSMA CON0	0	0	CSMATRN MODE	UNICAST FRM	0	CSMARCV EN	CSMATRN ST	CSMAST

CSMATRN MODE	Transmission-after-automatic-CSMA-CA mode
0	Wait timer is inserted (normal operation).
1	Wait time is minimized.

UNICAST FRM	Unicast frame
0	Unicast frame value = 0
1	Unicast frame value = 1

CSMARCV EN	Reception-during-CSMA-CA enable
0	Reception is disabled.
1	Reception is enabled.

CSMATRN ST	Transmission-after-automatic-CSMA-CA
0	Nothing proceeds.
1	Transmission proceeds after CSMA-CA.

CSMAST	Automatic CSMA-CA start
0	Nothing proceeds.
1	CSMA-CA is automatically started.

**Note:** Bit 0 is write-only.**Caution** When writing to this register, set bits 7, 6, and 3 to the value 0.

#### 4.2.14 Transmission and reception status register 2 (BBTXRXST2)

This register holds various information on the states of the RF transmission and reception. The reception RAM bank flag indicates the reception RAM bank used at the start of the reception. The receive data save bank flag indicates the receive data save bank at the start of the reception. The value of this register following a reset is 03H.

**Figure 4-15 Format of Transmission and Reception Status Register 2 (BBTXRXST2)**

Address: 0010H After reset: 03H R

Symbol	7	6	5	4	3	2	1	0
BBTXRXST 2	0	0	0	0	0	0	RCVSTORE FLG	RCVBANK FLG

RCVSTORE FLG	Receive data save bank flag
0	Receive data save bank 0
1	Receive data save bank 1

RCVBANK FLG	Reception RAM bank flag
0	Reception RAM bank 0
1	Reception RAM bank 1

### 4.2.15 Transmission and reception mode register 4 (BBTXRXMODE4)

The automatic-receive-with-timeout-after-transmission enable bit is used to specify whether to use the timeout function in the automatic receive operation after transmission when the automatic receive operation is enabled by the automatic receive switch mode 0 enable bit. The value of this register following a reset is 00H.

**Figure 4-16 Format of Transmission and Reception Mode Register 4 (BBTXRXMODE4)**

Address: 0011H After reset: 00H R/W

Symbol	7	6	5	4	3	2	1	0
BBTXRX MODE4	0	0	0	0	0	0	0	TIMEOUT RCV

TIMEOUT RCV	Automatic-receive-with-timeout-after-transmission enable
0	Normal automatic receive mode
1	Automatic receive mode with timeout function

**Caution** When writing to this register, set bits 7 to 1 to the value 0.



### 4.2.16 CSMA control register 1 (BBCSMA CON1)

This register is used to control the CSMA-CA operation. The macMaxCSMABackoff value is specified in the NB bits. Set a value from 0H to 5H. The CW value is specified in the CW bits. Set a value from 1H to 3H. The value of this register following a reset is 20H.

**Figure 4-17 Format of CSMA Control Register 1 (BBCSMA CON1)**

Address: 0012H After reset: 20H R/W

Symbol	7	6	5	4	3	2	1	0
BBCSMA CON1	0	0	CW1	CW0	0	NB2	NB1	NB0

CW1, CW0	CW value
----------	----------

NB2 to NB0	macMaxCSMABackoff value
------------	-------------------------

**Caution** When writing to this register, set bits 7, 6, and 3 to the value 0.

### 4.2.17 CSMA control register 2 (BBCSMA CON2)

This register is used to control the CSMA-CA operation. The macMaxBE value is specified in the BEMAX bits. Set the BEMAX bits to a greater value than that of the BEMIN bits. The maximum value is EH. The MacMinBE control bit selects whether to proceed the CCA operation when macMinBE is set to 000b, which is a parameter of automatic CSMA-CA. The unicast frame enable bit enables the operation specified by the unicast frame bit. The value of this register following a reset is 05H.

**Figure 4-18 Format of CSMA Control Register 2 (BBCSMA CON2)**

Address: 0013H After reset: 05H R/W

Symbol	7	6	5	4	3	2	1	0
BBCSMA CON2	0	0	UNICAST FRMEN	MACMINBE CON	BEMAX3	BEMAX2	BEMAX1	BEMAX0

UNICAST FRMEN	Unicast frame enable
0	Unicast frame is disabled.
1	Unicast frame is enabled.

MACMINBE CON	MacMinBE control
0	CCA operation does not proceed.
1	CCA operation proceeds.

BEMAX3 to BEMAX0	MacMaxBE value

**Caution** When writing to this register, set bits 7 and 6 to the value 0.

### 4.2.18 PAN identifier register 0 (BBPANID0)

This register is used to set the PAN identifier as a condition for filtering of the first address. It consists of 16 bits and the specified value is compared with the received PAN identifier to detect an address match. Set a value from 0000H to FFFFH in this register. The value of this register following a reset is FFFFH.

**Figure 4-19 Format of PAN Identifier Register 0 (BBPANID0)**

Address: 0015H, 0014H After reset: FFFFH R/W

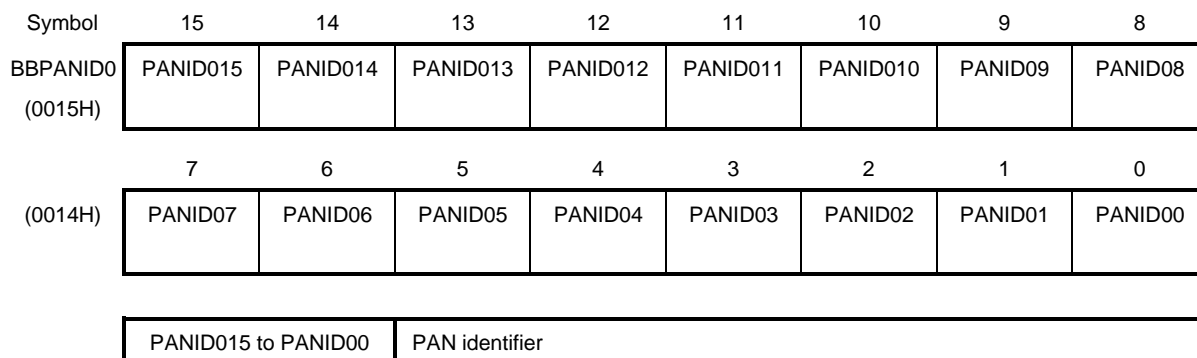

### 4.2.19 Short address register 0 (BBSHORTAD0)

This register is used to set the short address as a condition for filtering of the first address. It consists of 16 bits and the specified value is compared with the received short address to detect an address match. Set a value from 0000H to FFFFH in this register. The value of this register following a reset is FFFFH.

**Figure 4-20 Format of Short Address Register 0 (BBSHORTAD0)**

Address: 0017H, 0016H After reset: FFFFH R/W

Symbol	15	14	13	12	11	10	9	8
BBSHORTAD0 (0017H)	SHORTAD0 15	SHORTAD0 14	SHORTAD0 13	SHORTAD0 12	SHORTAD0 11	SHORTAD0 10	SHORTAD0 9	SHORTAD0 8
	7	6	5	4	3	2	1	0
(0016H)	SHORTAD0 7	SHORTAD0 6	SHORTAD0 5	SHORTAD0 4	SHORTAD0 3	SHORTAD0 2	SHORTAD0 1	SHORTAD0 0
	SHORTAD015 to SHORTAD00		Short address					

### 4.2.20 Extended address registers 0 (BBEXTENDAD00 to BBEXTENDAD03)

These registers are used to set the extended address as a condition for filtering of the first address. Four 16-bit registers are provided to specify a 64-bit address and the specified value is compared with the received extended address to detect an address match. Set a value from 0000H to FFFFH in these registers. The value of these registers following a reset is 0000H.

**Figure 4-21 Format of Extended Address Registers 0 (BBEXTENDAD00 to BBEXTENDAD03) (1/2)**

Address: 001FH, 001EH After reset: 0000H R/W

Symbol	15	14	13	12	11	10	9	8
BBEXTEN DAD03 (001FH)	EXTENDAD 0315	EXTENDAD 0314	EXTENDAD 0313	EXTENDAD 0312	EXTENDAD 0311	EXTENDAD 0310	EXTENDAD 039	EXTENDAD 038
	7	6	5	4	3	2	1	0
(001EH)	EXTENDAD 037	EXTENDAD 036	EXTENDAD 035	EXTENDAD 034	EXTENDAD 033	EXTENDAD 032	EXTENDAD 031	EXTENDAD 030
EXTENDAD0315 to EXTENDAD030		Bits 63 to 48 of extended address						

Address: 001DH, 001CH After reset: 0000H R/W

Symbol	15	14	13	12	11	10	9	8
BBEXTEN DAD02 (001DH)	EXTENDAD 0215	EXTENDAD 0214	EXTENDAD 0213	EXTENDAD 0212	EXTENDAD 0211	EXTENDAD 0210	EXTENDAD 029	EXTENDAD 028
	7	6	5	4	3	2	1	0
(001CH)	EXTENDAD 027	EXTENDAD 026	EXTENDAD 025	EXTENDAD 024	EXTENDAD 023	EXTENDAD 022	EXTENDAD 021	EXTENDAD 020
EXTENDAD0215 to EXTENDAD020		Bits 47 to 32 of extended address						

**Figure 4-22 Format of Extended Address Registers 0 (BBEXTENDAD00 to BBEXTENDAD03) (2/2)**

Address: 001BH, 001AH After reset: 0000H R/W

Symbol	15	14	13	12	11	10	9	8
BBEXTEN DAD01 (001BH)	EXTENDAD 0115	EXTENDAD 0114	EXTENDAD 0113	EXTENDAD 0112	EXTENDAD 0111	EXTENDAD 0110	EXTENDAD 019	EXTENDAD 018
	7	6	5	4	3	2	1	0
(001AH)	EXTENDAD 017	EXTENDAD 016	EXTENDAD 015	EXTENDAD 014	EXTENDAD 013	EXTENDAD 012	EXTENDAD 011	EXTENDAD 010
EXTENDAD0115 to EXTENDAD010		Bits 31 to 16 of extended address						

Address: 0019H, 0018H After reset: 0000H R/W

Symbol	15	14	13	12	11	10	9	8
BBEXTEN DAD00 (0019H)	EXTENDAD 0015	EXTENDAD 0014	EXTENDAD 0013	EXTENDAD 0012	EXTENDAD 0011	EXTENDAD 0010	EXTENDAD 009	EXTENDAD 008
	7	6	5	4	3	2	1	0
(0018H)	EXTENDAD 007	EXTENDAD 006	EXTENDAD 005	EXTENDAD 004	EXTENDAD 003	EXTENDAD 002	EXTENDAD 001	EXTENDAD 000
EXTENDAD0015 to EXTENDAD000		Bits 15 to 0 of extended address						

### 4.2.21 Timer read registers 0 and 1 (BBTIMEREAD0 and BBTIMEREAD1)

These registers are used to read the current value of the 32-bit timer. Be sure to start reading from the lowest-order byte. The counted value is latched when the lowest-order byte at address 0020H is read, so continue by reading the higher-order bytes. When the value read from the lowest-order byte at address 0020H is 00H, re-read from the lowest-order byte at the given address. Note that re-reading from the lowest-order byte should be done before the counter has counted to 256 so that the value of the lowest-order byte becomes 00H. The value of these registers following a reset is 0000H.

**Figure 4-23 Format of Timer Read Register 0 (BBTIMEREAD0)**

Address: 0021H, 0020H After reset: 0000H R

Symbol	15	14	13	12	11	10	9	8
BBTIMEREAD0	TIMEREAD0	TIMEREAD0	TIMEREAD0	TIMEREAD0	TIMEREAD0	TIMEREAD0	TIMEREAD0	TIMEREAD0
AD0 (0021H)	15	14	13	12	11	10	9	8
	7	6	5	4	3	2	1	0
(0020H)	TIMEREAD0	TIMEREAD0	TIMEREAD0	TIMEREAD0	TIMEREAD0	TIMEREAD0	TIMEREAD0	TIMEREAD0
	7	6	5	4	3	2	1	0
TIMEREAD015 to TIMEREAD00		Lower-order bits of 32-bit timer value (bits 15 to 0)						

**Figure 4-24 Format of Timer Read Register 1 (BBTIMEREAD1)**

Address: 0023H, 0022H After reset: 0000H R

Symbol	15	14	13	12	11	10	9	8
BBTIMEREAD1	TIMEREAD1	TIMEREAD1	TIMEREAD1	TIMEREAD1	TIMEREAD1	TIMEREAD1	TIMEREAD1	TIMEREAD1
AD1 (0023H)	15	14	13	12	11	10	9	8
	7	6	5	4	3	2	1	0
(0022H)	TIMEREAD1	TIMEREAD1	TIMEREAD1	TIMEREAD1	TIMEREAD1	TIMEREAD1	TIMEREAD1	TIMEREAD1
	7	6	5	4	3	2	1	0
TIMEREAD115 to TIMEREAD10		Higher-order bits of 32-bit timer value (bits 31 to 16)						

#### 4.2.22 Timer comparison registers 0 and 1 (BBTCOMP0REG0 to BBTCOMP2REG0 and BBTCOMP0REG1 to BBTCOMP2REG1)

These registers are used to specify the values to be compared with the 32-bit timer. There are three channels of registers. All channels are individually compared with the 32-bit timer. The value of these registers following a reset is 0000H.

**Figure 4-25 Format of Timer Comparison Registers 0 (BBTCOMPnREG0)**

Address: 002DH, 002CH (BBTCOMP2REG0), 0029H, 0028H (BBTCOMP1REG0), 0025H, 0024H (BBTCOMP0REG0)

After reset: 0000H R/W

Symbol	15	14	13	12	11	10	9	8
BBTCOMP nREG0 (002DH) (0029H) (0025H)	TCOMPn REG015	TCOMPn REG014	TCOMPn REG013	TCOMPn REG012	TCOMPn REG011	TCOMPn REG010	TCOMPn REG09	TCOMPn REG08
	7	6	5	4	3	2	1	0
(002CH) (0028H) (0024H)	TCOMPn REG07	TCOMPn REG06	TCOMPn REG05	TCOMPn REG04	TCOMPn REG03	TCOMPn REG02	TCOMPn REG01	TCOMPn REG00
	TCOMPnREG015 to TCOMPnREG00		Lower-order bits of 32-bit comparison value (bits 15 to 0)					

**Caution** n = 0 to 2



Figure 4-26 Format of Timer Comparison Registers 1 (BBTCOMPnREG1)

Address: 002FH, 002EH (BBTCOMP2REG1), 002BH, 002AH (BBTCOMP1REG1), 0027H, 0026H (BBTCOMP0REG1)

After reset: 0000H R/W

Symbol	15	14	13	12	11	10	9	8
BBTCOMP nREG1 (002FH) (002BH) (0027H)	TCOMPn REG115	TCOMPn REG114	TCOMPn REG113	TCOMPn REG112	TCOMPn REG111	TCOMPn REG110	TCOMPn REG19	TCOMPn REG18
	7	6	5	4	3	2	1	0
(002EH) (002AH) (0026H)	TCOMPn REG17	TCOMPn REG16	TCOMPn REG15	TCOMPn REG14	TCOMPn REG13	TCOMPn REG12	TCOMPn REG11	TCOMPn REG10
	TCOMPnREG115 to TCOMPnREG10		Higher-order bits of 32-bit comparison value (bits 31 to 16)					

**Caution n = 0 to 2**

### 4.2.23 Timestamp registers 0 and 1 (BBTSTAMP0 and BBTSTAMP1)

These registers hold the timer count value that is stored when reception of packet data is started or completed or when transmission of packet data is completed. The timestamps of reception and transmission are separately stored, and the stamp value read switch bits are used to select the value to be read from these registers from among the reception start stamp, reception completion stamp, and transmission stamp. The timer value upon starting of the reception is automatically stored as a timestamp and it is retained until the reception of the next packet is started. The timer value upon completion of the reception is automatically stored as a timestamp and it is retained until the reception of the next packet is completed. The timestamp value corresponding to the save bank specified by the receive data save bank select bit is read from these registers. The timer value upon completion of the transmission is automatically stored as another timestamp and it is retained until the transmission of the next packet is completed. However, the transmission timestamp value is not updated during automatic ACK reply. The value of these registers following a reset is 0000H.

**Figure 4-27 Format of Timestamp Register 0 (BBTSTAMP0)**

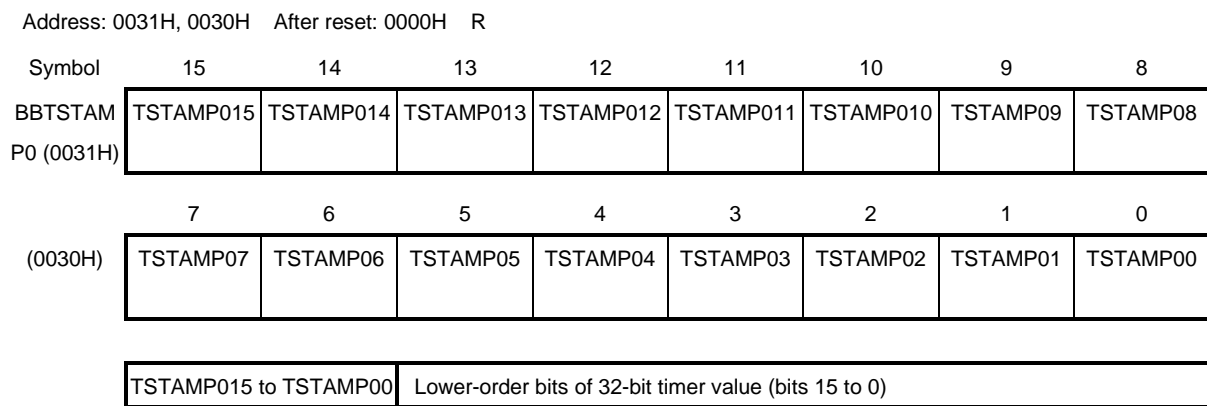

**Figure 4-28 Format of Timestamp Register 1 (BBTSTAMP1)**

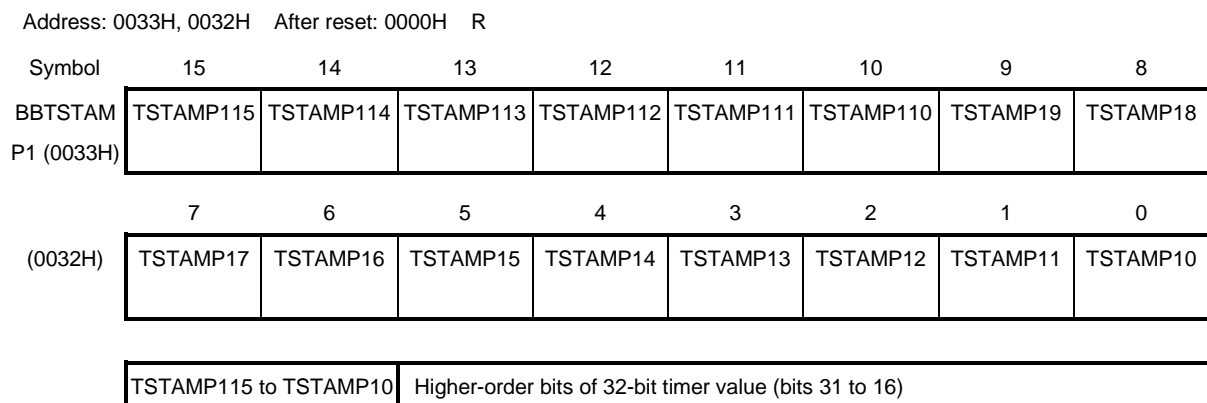

#### 4.2.24 Timer control register (BBTIMECON)

This register is used to control the timer in this device. The timer count enable bit controls the count operation of the 32-bit timer. Setting this bit to 1 enables the count operation. Clearing it to 0 stops the timer and initializes the timer count value to 00000000H. The COMP0 transmit trigger enable bit enables the start of RF transmission when the timer count value matches the value of the timer comparison registers 0 and 1 (BBTCOMP1REG0 and BBTCOMP1REG1). Transmission starts in 335  $\mu$ s after the match. Be sure to set this bit in the IDLE state. The stamp timing switch bit selects the timing of getting the stamp of the timer count value. The value is updated upon the start of reception regardless of the address filter function when the start of reception is selected as the stamp timing. The COMP0 trigger select bit selects CSMA-CA as the function to be started when the COMP0 transmit trigger enable bit is enabled. The stamp value read switch bits select the value to be read from the time stamp registers from among the reception start stamp value, reception completion stamp value, and the transmission completion stamp value. The count source switch bit switches the count source for the timer between the prescaler output and the data rate specified in the timing parameter data rate setting register. The COMP0-excess transmission enable bit is used to immediately place this device in the transmission start state if the timer count has already exceeded the comp 0 value when the value is specified in timer comparison registers 0 and 1 (BBTCOMP1REG0 and BBTCOMP1REG1) while the COMP0 transmit trigger enable bit is set (enabled). The value of this register following a reset is 00H.

Figure 4-29 Format of Timer Control Register (BBTIMECON)

Address: 0034H After reset: 00H R/W

Symbol	7	6	5	4	3	2	1	0
BBTIME	PASSSTART	CNTSRC	STAMPRD	STAMPRD	COMP0TRG	STAMPTIM	COMP0TRG	TIMEEN
CON	EN	SEL	SEL1	SEL0	SEL	SEL		

PASSSTART EN	COMP0-excess transmission enable	
0	Transmission is disabled.	
1	Transmission is enabled.	

CNTSRC SEL	Count source switch	
0	Prescaler output (1 $\mu$ s)	
1	Data rate specified in the timing parameter data rate setting register	

STAMPRD SEL1	STAMPRD SEL0	Stamp value read switch	
0	0	Reception start stamp value	
0	1	Reception completion stamp value	
1	0	Transmission completion stamp value	
1	1		

COMP0TRG SEL	COMP0 trigger select	
0	Transmit trigger	
1	CSMA-CA trigger	

STAMPTIM SEL	Stamp timing switch	
0	Start of reception	
1	Generation of frame length interrupt	

COMP0TRG	COMP0 transmit trigger enable	
0	Transmit trigger is disabled.	
1	Transmit trigger is enabled.	

TIMEEN	Timer count enable	
0	Counting by the timer is stopped.	
1	Counting by the timer is enabled.	

### 4.2.25 Backoff period register (BBOFFPROD)

This register is used to control the backoff period. The automatic random backoff period enable bit is used to automatically generate random values by using the value specified in the backoff period register 2 as the initial value to set the backoff period value in the CSMA-CA circuit. Set a random value in backoff period register 2 and then set the automatic random backoff period enable bit in the backoff period register to 1. The value of this register following a reset is 00H.

**Figure 4-30 Format of Backoff Period Register (BBOFFPROD)**

Address: 0035H After reset: 00H R/W

Symbol	7	6	5	4	3	2	1	0
BBOFF PROD	0	0	0	0	0	0	0	BOFFPROD EN

BOFFPROD EN	Automatic random backoff period enable
0	Automatic generation of random values is disabled.
1	Automatic generation of random values is enabled.

**Caution** When writing to this register, set bits 7 to 1 to the value 0.

### 4.2.26 Timing parameter data rate setting register (BBPARAMRATE)

This register is used to set the data rate for timing parameters such as the count sources of the timer and backoff period. Specify the value corresponding to the desired data rate shown in Table 4-2. The extended data rate enable bit enables the setting of the data rate in the extended data rate setting register. The value of this register following a reset is 00H.

**Figure 4-31 Format of Timing Parameter Data Rate Setting Register (BBPARAMRATE)**

Address: 0036H After reset: 00H R/W

Symbol	7	6	5	4	3	2	1	0
BBPARAM RATE	0	0	0	0	EXTRATE EN	PARAM RATE2	PARAM RATE1	PARAM RATE0

EXTRATE EN	Extended data rate enable
0	Extended data rate is disabled.
1	Extended data rate is enabled.

PARAMRATE2 to PARAMRATE0	Timing parameter data rate setting
—	These bits set the data rate for timing parameters.

**Caution** When writing to this register, set bits 7 to 4 to the value 0.

**Table 4-2 Data Rate Setting**

Value			Data Rate	Cycle
PARAM RATE2	PARAM RATE1	PARAM RATE0		
0	0	0	1000 kbps	1 $\mu$ s
0	0	1	100 kchip/s	320 $\mu$ s
0	1	0	10 kbps	100 $\mu$ s
0	1	1	20 kbps	50 $\mu$ s
1	0	0	50 kbps	20 $\mu$ s
1	0	1	100 kbps	10 $\mu$ s
1	1	0	150 kbps	6.667 $\mu$ s
1	1	1	200 kbps	5 $\mu$ s

### 4.2.27 Extended data rate setting register (BBEXTRATE)

This register is used to set the value other than those set by the PARAMRATE2 to PARAMRATE0 bits in the timing parameter data rate setting register (BBPARAMRATE). The extended data rate enable bit enables the setting of this register.

Data rate [bps] = (48 MHz / 2) / the extended data rate

The value of this register following a reset is 00F0H.

**Figure 4-32 Format of Extended Data Rate Setting Register (BBEXTRATE)**

Address: 0039H, 0038H After reset: 00F0H R/W

Symbol	15	14	13	12	11	10	9	8
BBEXT RATE (0039H)	EXTRATE 15	EXTRATE 14	EXTRATE 13	EXTRATE 12	EXTRATE 11	EXTRATE 10	EXTRATE 9	EXTRATE 8
	7	6	5	4	3	2	1	0
(0038H)	EXTRATE 7	EXTRATE 6	EXTRATE 5	EXTRATE 4	EXTRATE 3	EXTRATE 2	EXTRATE 1	EXTRATE 0
EXTRATE15 to EXTRATE0		Bits 15 to 0 of the extended data rate						

### 4.2.28 CSMA control register 3 (BBCSMA CON3)

This register is used to control the CSMA-CA operation. The macMinBE value is specified in the BEMIN bits. Set the BEMIN bits to a smaller value than that of the BEMAX bits. The minimum value is 0H. To proceed CCA, specify a value other than 0H. The value of this register following a reset is 03H.

**Figure 4-33 Format of CSMA Control Register 3 (BBCSMA CON3)**

Address: 003EH After reset: 03H R/W

Symbol	7	6	5	4	3	2	1	0
BBCSMA CON3	0	0	0	0	BEMIN3	BEMIN2	BEMIN1	BEMIN0

BEMIN3 to BEMIN0	BEMIN (macMinBE value)
---------------------	------------------------

**Caution** When writing to this register, set bits 7 to 4 to the value 0.



### 4.2.29 Calibration register (BBCAL)

This register is used to control calibration. Set the calibration start bit to start calibration. The value of this register following a reset is 00H.

**Figure 4-34 Format of Calibration Register (BBCAL)**

Address: 003FH After reset: 00H R/W

Symbol	7	6	5	4	3	2	1	0
BBCAL	0	0	0	0	0	0	0	CALSTART

CALSTART	Calibration start
0	Nothing proceeds.
1	Calibration is started.

**Caution** When writing to this register, set bits 7 to 1 to the value 0.

### 4.2.30 ACK reply time setting register (ACKRTNTIM)

This register is used to set the ACK reply time in the non-beacon mode. Set a value from 0001H to FFFFH in this register. The value of this register following a reset is 0002H.

**Figure 4-35 Format of ACK Reply Time Setting Register (ACKRTNTIM)**

Address: 0047H, 0046H After reset: 0002H R/W

Symbol	15	14	13	12	11	10	9	8
ACKRTNTIM (0047H)	ACKRTNTIM15	ACKRTNTIM14	ACKRTNTIM13	ACKRTNTIM12	ACKRTNTIM11	ACKRTNTIM10	ACKRTNTIM9	ACKRTNTIM8
(0046H)	ACKRTNTIM7	ACKRTNTIM6	ACKRTNTIM5	ACKRTNTIM4	ACKRTNTIM3	ACKRTNTIM2	ACKRTNTIM1	ACKRTNTIM0

ACKRTNTIM15 to ACKRTNTIM0	ACK reply time in the non-beacon mode
---------------------------	---------------------------------------

**Example of setting:** Non-beacon mode

Only use the ACK reply time setting register to set the time from the completion of packet reception to the assertion of the transmission trigger signal. The initial value is 0002H, that is, 2 data rate time<sup>Note</sup>. The setting is possible in 1 data rate time<sup>Note</sup> units (1H = 1 data rate time<sup>Note</sup>).

Note: The rate time depends on the value specified in the timing parameter data rate setting register.

In the non-beacon mode, the 10-bit timer counter for ACK reply mode starts counting from 000H when reception is completed, and the counter stops and the transmission trigger signal is asserted when the timer count reaches the value specified in the ACK reply time setting register.

**Figure 4-36 Count Operation in the Non-Beacon Mode**

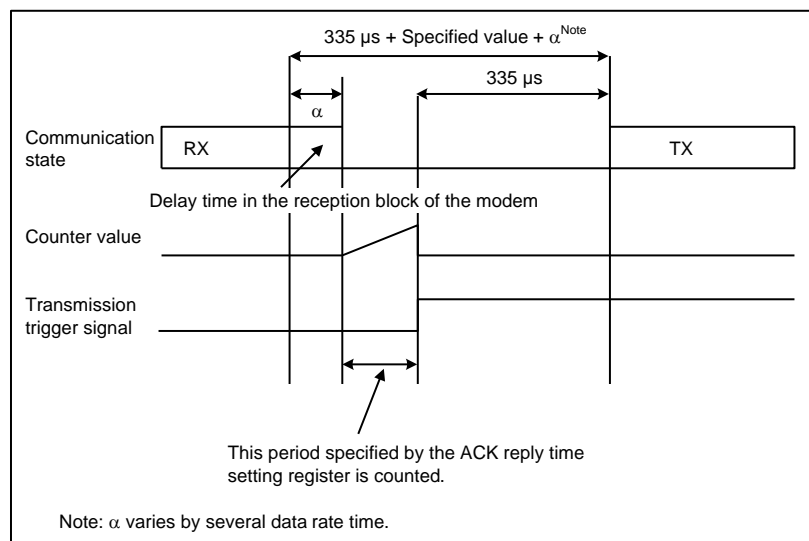

### 4.2.31 Automatic switching to reception comparison register (AUTORCVCNT)

This register is used to set the time until the reception trigger signal is asserted for automatic switching to reception after the completion of transmission or reception when the automatic receive switch mode is specified. The initial value is 000AH, that is, 10 data rate time<sup>Note</sup>. The setting is possible in 1 data rate time<sup>Note</sup> units (1H = 1 data rate time<sup>Note</sup>).

Note: The rate time depends on the value specified in the timing parameter data rate setting register.

Set a value from 0001H to FFFFH in this register. The value of this register following a reset is 000AH.

**Figure 4-37 Format of Automatic Switching to Reception Comparison Register (AUTORCVCNT)**

Address: 0049H, 0048H After reset: 000AH R/W

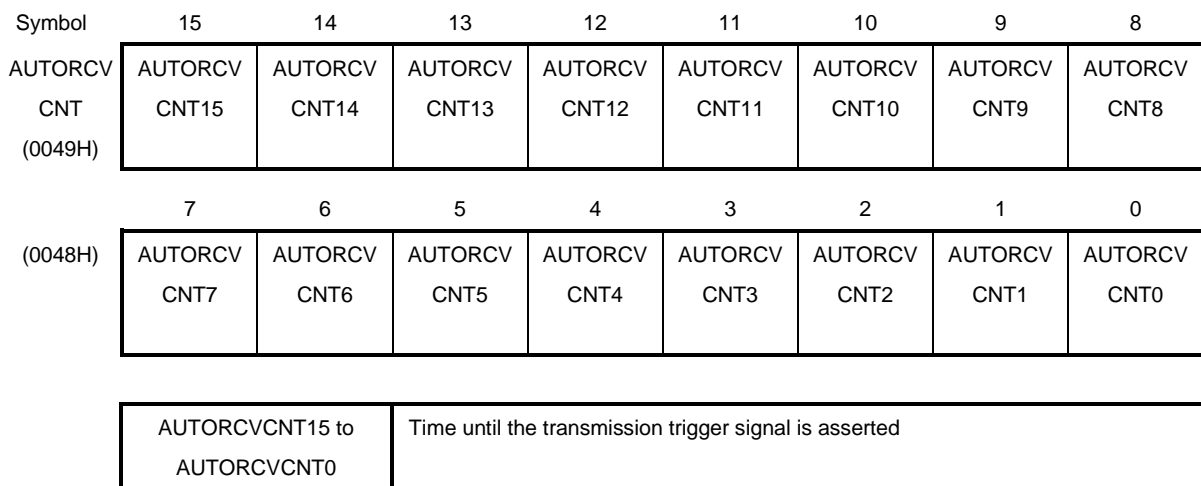

**Figure 4-38 Count Operation Specified by the Automatic Switching to Reception Comparison Register**

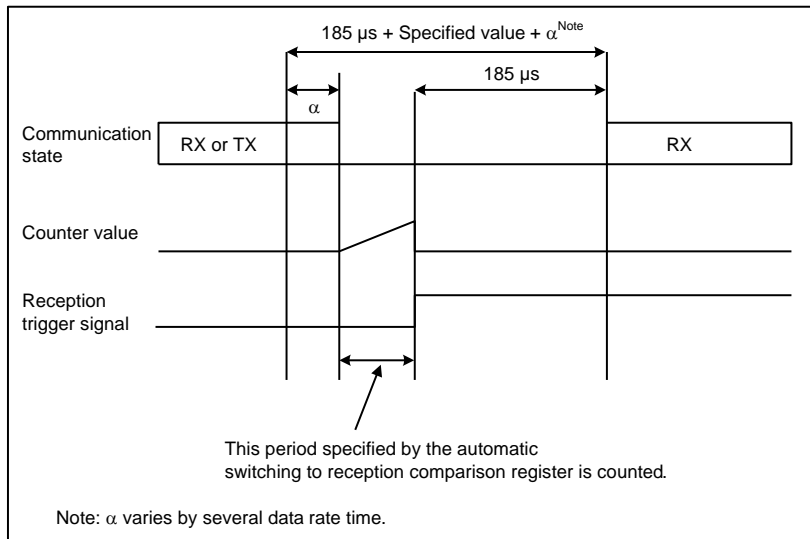

### 4.2.32 Backoff cycle register (BOFFPERIOD)

This register is used to set the backoff cycle. The initial value is 0071H, that is, 113 data rate time<sup>Note</sup>. The setting is possible in 1 data rate time<sup>Note</sup> units (1H = 1 data rate time<sup>Note</sup>).

Note: The rate time depends on the value specified in the timing parameter data rate setting register.

Set a value from 000FH to FFFFH in this register. The value of this register following a reset is 0071H.

**Figure 4-39 Format of Backoff Cycle Register (BOFFPERIOD)**

Address: 004BH, 004AH After reset: 0071H R/W

Symbol	15	14	13	12	11	10	9	8
BOFFPERIOD (004BH)	BOFF PERIOD15	BOFF PERIOD14	BOFF PERIOD13	BOFF PERIOD12	BOFF PERIOD11	BOFF PERIOD10	BOFF PERIOD9	BOFF PERIOD8
	7	6	5	4	3	2	1	0
(004AH)	BOFF PERIOD7	BOFF PERIOD6	BOFF PERIOD5	BOFF PERIOD4	BOFF PERIOD3	BOFF PERIOD2	BOFF PERIOD1	BOFF PERIOD0
	BOFFPERIOD15 to BOFFPERIOD0		Backoff cycle value					

### 4.2.33 CSMA-CA end count register (CSMAENDCOUNT)

This register is used to set the time between the completion of CCA and the transition to the idle state when the automatic CSMA/CA sequence is used. The initial value is 0080H, that is, 128  $\mu$ s. The setting is possible in 1- $\mu$ s units (1H = 1  $\mu$ s). Set a value from 0002H to FFFFH in this register. The value of this register following a reset is 0080H.

**Figure 4-40 Format of CSMA-CA End Count Register (CSMAENDCOUNT)**

Address: 004DH, 004CH After reset: 0080H R/W

Symbol	15	14	13	12	11	10	9	8
CSMAEND COUNT (004DH)	CSMAEND COUNT15	CSMAEND COUNT14	CSMAEND COUNT13	CSMAEND COUNT12	CSMAEND COUNT11	CSMAEND COUNT10	CSMAEND COUNT9	CSMAEND COUNT8
	7	6	5	4	3	2	1	0
(004CH)	CSMAEND COUNT7	CSMAEND COUNT6	CSMAEND COUNT5	CSMAEND COUNT4	CSMAEND COUNT3	CSMAEND COUNT2	CSMAEND COUNT1	CSMAEND COUNT0
CSMAENDCOUNT15 to CSMAENDCOUNT0		Time between the completion of CCA and the transition to the idle state						

### 4.2.34 CSMA-CA start count register (CSMASTACOUNT)

This register is used to adjust the timing of starting CCA when the automatic CSMA-CA sequence is in use. The initial value is 000EH, that is, 14 data rate time<sup>Note</sup>. The setting is possible in 1 data rate time<sup>Note</sup> units (1H = 1 data rate time<sup>Note</sup>).

Note: The rate time depends on the value specified in the timing parameter data rate setting register.

Set a value from 0002H to FFFFH in this register. The value of this register following a reset is 000EH.

**Figure 4-41 Format of CSMA-CA Start Count Register (CSMASTACOUNT)**

Address: 004FH, 004EH After reset: 000EH R/W

Symbol	15	14	13	12	11	10	9	8
CSMASTA COUNT (004FH)	CSMASTA COUNT15	CSMASTA COUNT14	CSMASTA COUNT13	CSMASTA COUNT12	CSMASTA COUNT11	CSMASTA COUNT10	CSMASTA COUNT9	CSMASTA COUNT8
	7	6	5	4	3	2	1	0
(004EH)	CSMASTA COUNT7	CSMASTA COUNT6	CSMASTA COUNT5	CSMASTA COUNT4	CSMASTA COUNT3	CSMASTA COUNT2	CSMASTA COUNT1	CSMASTA COUNT0
CSMASTACOUNT15 to CSMASTACOUNT0		Warm-up time before CCA is started						

### 4.2.35 Communication status register 1 (COMSTATE1)

This register is used to check various information on communication states. The transmission status, CCA status, and frame reception status bits indicate whether this device is in the transmission, CCA, and frame reception states, respectively.

**Figure 4-42 Format of Communication Status Register 1 (COMSTATE1)**

Address: 0066H After reset: XXXX000XB R

Symbol	7	6	5	4	3	2	1	0
COMSTAT E1	X	X	X	X	FRCVSTATE	CCASTATE	TRNSTATE	X

FRCVSTATE	Frame reception status
0	Reception has not started.
1	Reception is in progress.

CCASTATE	CCA status
0	CCA has not started.
1	CCA is in progress.

TRNSTATE	Transmission status
0	Transmission has not started.
1	Transmission is in progress.

**Caution** An undefined value (X) is read from bits 0 and 7 to 4.

### 4.2.36 Communication status register 2 (COMSTATE2)

This register is used to check various information on communication states. The ACK reply status bit indicates whether this device is in the ACK reply operation state.

**Figure 4-43 Format of Communication Status Register 2 (COMSTATE2)**

Address: 0067H After reset: XXXXXX0B R

Symbol	7	6	5	4	3	2	1	0
COMSTAT E2	X	X	X	X	X	X	X	ACKSTATE

ACKSTATE	ACK reply status
0	ACK reply has not started.
1	ACK reply is in progress.

**Caution** An undefined value (X) is read from bits 7 to 1.



### 4.2.37 Evaluation control register (BBEVAREG)

This register is used to set the evaluation mode required to obtain the certification of conformance to technical standards. Setting both the continuous transmit mode bit and transmit trigger bit to 1 places this device in the continuous transmit mode. In this mode, data transmission is repeated for the number of data bytes specified in the transmitted frame length register minus the number of CRC bytes. Note that the data written to the transmission RAM are transmitted. The non-modulation switch bit can select the modulation signal or non-modulation signal. When using this bit, be sure to set the transmission method to FSK by the transmission method selection bit. Setting both the continuous receive mode bit and receive trigger bit to 1 places the device in the continuous receive mode. In this mode, the device does not enter the IDLE state but remains in the receive state after completing data reception. The value of this register following a reset is 00H.

**Figure 4-44 Format of Evaluation Control Register (BBEVAREG)**

Address: 0068H After reset: 00H R/W

Symbol	7	6	5	4	3	2	1	0
BBEVA REG	0	0	0	0	0	CONTRX	NOMOD	CONTTX

CONTRX	Continuous receive mode
0	Normal operation
1	Continuous receive operation

NOMOD	Non-modulation switch
0	Modulation signal
1	Non-modulation signal

CONTTX	Continuous transmit mode
0	Normal operation
1	Continuous transmit operation

**Caution** When writing to this register, set bits 7 to 3 to the value 0.

### 4.2.38 Backoff period register 2 (BBBOFFPROD2)

This register is used to set a random value for the backoff period of CSMA-CA. Set a random value in backoff period bits 0 to 7, and then set the automatic random backoff period enable bit of the backoff period register to 1. Set a value from 01H to FFH in this register. The value of this register following a reset is 00H.

**Figure 4-45 Format of Backoff Period Register 2 (BBBOFFPROD2)**

Address: 0069H After reset: 00H R/W

Symbol	7	6	5	4	3	2	1	0
BBBOFF PROD2	BOFFPROD 7	BOFFPROD 6	BOFFPROD 5	BOFFPROD 4	BOFFPROD 3	BOFFPROD 2	BOFFPROD 1	BOFFPROD 0

BOFFPROD7 to BOFFPROD0	Backoff period value
---------------------------	----------------------

### 4.2.39 Communication status register 3 (COMSTATE3)

This register indicates the communication state. The number of retransmissions can be read from the RETRNRD3 to RETRNRD0 bits when the automatic ACK receive mode is enabled. The number of times the last CCA was handled can be read from the CCARD2 to CCARD0 bits. The value of this register following a reset is 00H.

**Figure 4-46 Format of Communication Status Register 3 (COMSTATE3)**

Address: 006FH After reset: 00H R

Symbol	7	6	5	4	3	2	1	0
COMSTAT E3	0	CCARD2	CCARD1	CCARD0	RETRNRD3	RETRNRD2	RETRNRD1	RETRNRD0
	CCARD2 to CCARD0			Number of times the last CCA proceeds (3 bits).				
	RETRNRD3 to RETRNRD0				Number of retransmissions when the automatic ACK receive mode is enabled (4 bits).			

#### 4.2.40 ACK reception wait time setting register (ACKRCVWIT)

This register is used to set the ACK receive wait time after the data transmission. Data are retransmitted when there is no ACK reply even after a wait for the specified time. The initial value is 0300H, that is, 768 data rate time<sup>Note</sup>. The setting is possible in 1 data rate time<sup>Note</sup> units (1H = 1 data rate time<sup>Note</sup>).

Note: The rate time depends on the value specified in the timing parameter data rate setting register.

The timing to detect ACK reception is switched by the ACK receive point setting bit. Set a value from 0001H to FFFFH in this register. The value of this register following a reset is 0300H.

**Figure 4-47 Format of ACK Reception Wait Time Setting Register (ACKRCVWIT)**

Address: 0071H, 0070H After reset: 0300H R/W

Symbol	15	14	13	12	11	10	9	8
ACKRCVWIT (0071H)	ACKRCV WIT15	ACKRCV WIT14	ACKRCV WIT13	ACKRCV WIT12	ACKRCV WIT11	ACKRCV WIT10	ACKRCV WIT9	ACKRCV WIT8
	7	6	5	4	3	2	1	0
(0070H)	ACKRCV WIT7	ACKRCV WIT6	ACKRCV WIT5	ACKRCV WIT4	ACKRCV WIT3	ACKRCV WIT2	ACKRCV WIT1	ACKRCV WIT0
ACKRCVWIT15 to ACKRCVWIT0		ACK receive wait time						

#### 4.2.41 Retransmission start comparison register (RETRNWUP)

This register is used to set the wait time until a trigger for retransmission is generated. The initial value is 0004H, that is, 4 data rate time<sup>Note</sup>. The setting is possible in 1 data rate time<sup>Note</sup> units (1H = 1 data rate time<sup>Note</sup>).

Note: The rate time depends on the value specified in the timing parameter data rate setting register.

Set a value from 0001H to FFFFH in this register. The value of this register following a reset is 0004H.

**Figure 4-48 Format of Retransmission Start Comparison Register (RETRNWUP)**

Address: 0073H, 0072H After reset: 0004H R/W

Symbol	15	14	13	12	11	10	9	8
RETRNWUP (0073H)	RETRNWUP 15	RETRNWUP 14	RETRNWUP 13	RETRNWUP 12	RETRNWUP 11	RETRNWUP 10	RETRNWUP 9	RETRNWUP 8
	7	6	5	4	3	2	1	0
(0072H)	RETRNWUP 7	RETRNWUP 6	RETRNWUP 5	RETRNWUP 4	RETRNWUP 3	RETRNWUP 2	RETRNWUP 1	RETRNWUP 0
	RETRNWUP15 to RETRNWUP0		Wait time until a trigger for retransmission is generated					

#### 4.2.42 Received frame length register (BBRXFLEN)

This register holds the received frame length value. The value is stored once the packet data reception is started. The value is retained until the start of the next packet data reception. However, the register is updated when the address match is detected if the address filter is enabled. The value corresponding to the save bank specified by the receive data save bank select bit is read from this register. The value of this register following a reset is 0000H.

**Figure 4-49 Format of Received Frame Length Register (BBRXFLEN)**

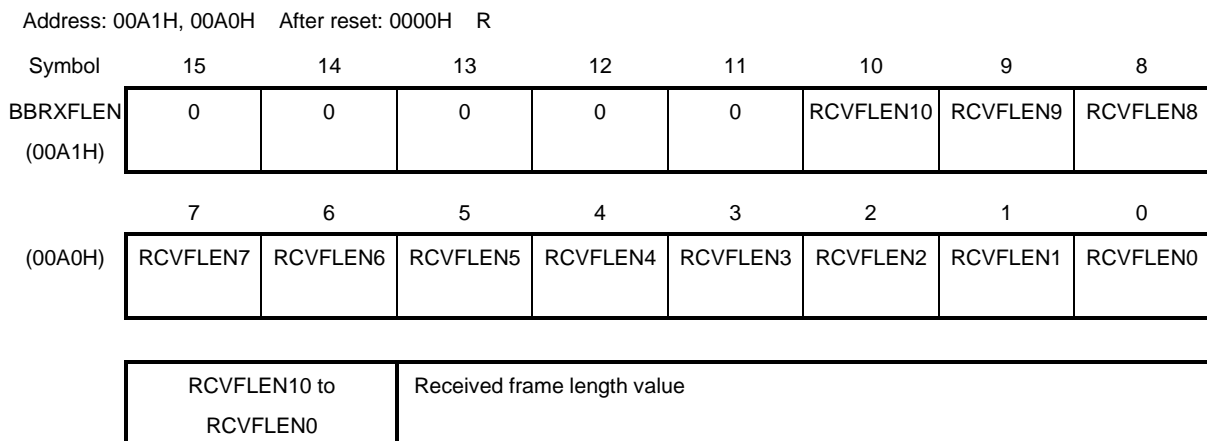

#### 4.2.43 Received data counter register (BBRXCOUNT)

This register indicates the received data counter value. The number of received data bytes that have been stored in the reception RAM can be read from this register. The value is cleared to 0 when packet reception ends. When the value read from the lower-order byte at address 00A2H is 00H, re-read from the lower-order byte at the given address. Note that re-reading from the lower-order byte should be done before the counter has counted to 256 so that the value of the lower-order byte becomes 00H. The value of this register following a reset is 0000H.

**Figure 4-50 Format of Received Data Counter Register (BBRXCOUNT)**

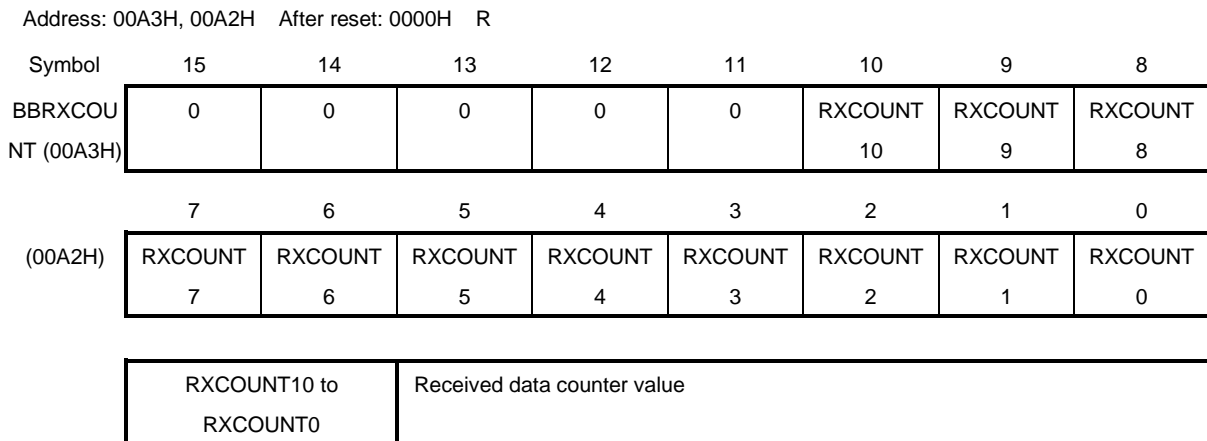

#### 4.2.44 Transmitted frame length register (BBTXFLEN)

This register is used to set the frame length for transmission. Set the sum of the payload data length and CRC length (2 bytes or 4 bytes). When the automatic ACK reply function is enabled, ACK is automatically transmitted regardless of the frame length. Set a value from 0003H to 07FFH in this register. The value of this register following a reset is 0000H.

**Figure 4-51 Format of Transmitted Frame Length Register (BBTXFLEN)**

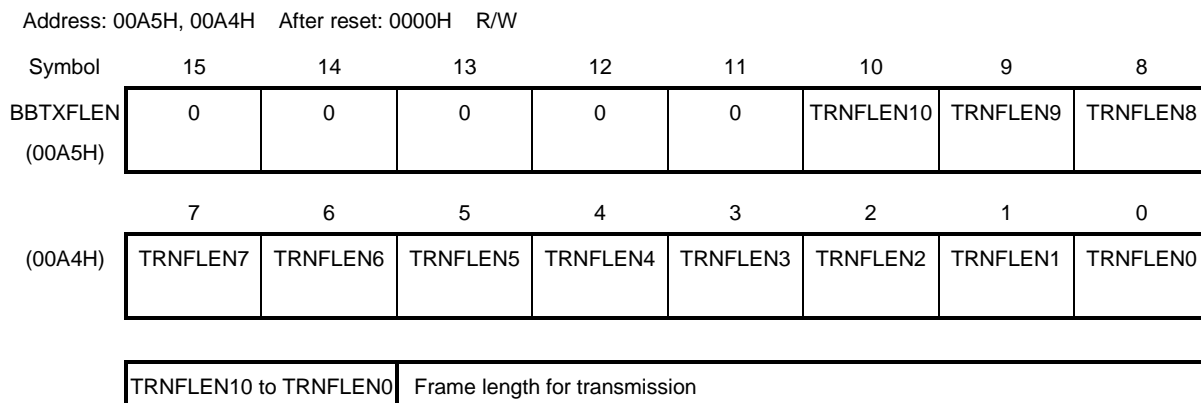

**Caution** When writing to this register, set bits 15 to 11 to the value 0.



#### 4.2.45 Frequency setting register (BBFREQ)

This register is used to set a frequency. This register consists of 30 bits. The frequency ranged from 100 MHz to 1000 MHz can be set in 1-Hz steps. The initial value is 36FC3BA0H, that is, 922.5 MHz. Set a value from 337055C0H (863 MHz) to 37502800H (928 MHz) in this register. All four bytes should be specified in the order from the lowest to the highest address. The value of this register following a reset is 36FC3BA0H.

**Figure 4-52 Format of Frequency Setting Register (BBFREQ)**

Address: 00ABH to 00A8H After reset: 36FC3BA0H R/W

Symbol	31	30	29	28	27	26	25	24
BBFREQ (00ABH)	0	0	FREQ29	FREQ28	FREQ27	FREQ26	FREQ25	FREQ24
	23	22	21	20	19	18	17	16
(00AAH)	FREQ23	FREQ22	FREQ21	FREQ20	FREQ19	FREQ18	FREQ17	FREQ16
	15	14	13	12	11	10	9	8
(00A9H)	FREQ15	FREQ14	FREQ13	FREQ12	FREQ11	FREQ10	FREQ9	FREQ8
	7	6	5	4	3	2	1	0
(00A8H)	FREQ7	FREQ6	FREQ5	FREQ4	FREQ3	FREQ2	FREQ1	FREQ0
	FREQ29 to FREQ0		Frequency value					

**Caution** When writing to this register, set bits 31 and 30 to the value 0.

#### 4.2.46 IF frequency setting register (BBIFSET)

The IF frequency setting bit is used to set the IF frequency. The frequency offset enable bit enables the function of the SX shift frequency setting register. The IF frequency offset enable bit enables or disables the setting of the offset value for the IF frequency. The offset value is set according to the setting in IF frequency offset setting register 0 or 1. The IF frequency offset selection bit is used to select whether the value in IF frequency offset setting register 0 or 1 is to be used. The value of this register following a reset is 00H.

**Figure 4-53 Format of IF Frequency Setting Register (BBIFSET)**

Address: 00ACH After reset: 00H R/W

Symbol	7	6	5	4	3	2	1	0
BBIFSET	0	0	0	0	IFOFSTSEL	IFOFSTEN	SFOFSET EN	IFSET

IFOFSTSEL	IF frequency offset selection
0	The value in IF frequency offset setting register 0 is to be used.
1	The value in IF frequency offset setting register 1 is to be used.

IFOFSTEN	IF frequency offset enable
0	IF frequency offset value setting is disabled.
1	IF frequency offset value setting is enabled.

SFOFSET EN	Frequency offset enable
0	Frequency shift setting is disabled.
1	Frequency shift setting is enabled.

IFSET	IF frequency setting
0	550 kHz
1	750 kHz

**Caution** When writing to this register, set bits 7 to 4 to the value 0.

#### 4.2.47 SX shift frequency setting register (BBSXSFTFREQ)

The SX shift frequency setting bits are used to set the amount of SX frequency shifting (1H = 1 kHz). The frequency offset enable bit enables the setting of this register.

000H: 0 kHz

001H: 1 kHz

002H: 2 kHz

:

0C8H: 200 kHz

:

7FFH: 2047 kHz

800H: 0 kHz

801H: -1 kHz

802H: -2 kHz

:

8C8H: -200 kHz

:

FFFH: -2047 kHz

The value of this register following a reset is 0000H.

**Figure 4-54 Format of SX Shift Frequency Setting Register (BBSXSFTFREQ)**

Address: 00AEH, 00ADH After reset: 0000H R/W

Symbol	15	14	13	12	11	10	9	8
BBSXSFTF REQ (00AEH)	0	0	0	0	SXSFTF REQ11	SXSFTF REQ10	SXSFT FREQ9	SXSFTF REQ8
(00ADH)	7	6	5	4	3	2	1	0
	SXSFTF REQ7	SXSFTF REQ6	SXSFTF REQ5	SXSFTF REQ4	SXSFTF REQ3	SXSFTF REQ2	SXSFTF REQ1	SXSFTF REQ0
	SXSFTFREQ11 to SXSFTFREQ0		SX shift frequency setting					
	—		These bits set the amount of SX frequency shifting.					

**Caution** When writing to this register, set bits 15 to 12 to the value 0.

#### 4.2.48 CCA time register (CCATIME)

This register is used to set the time taken for the CCA processing. The initial value is 000DH, that is, 13 data rate time<sup>Note</sup>. The setting is possible in 1 data rate time<sup>Note</sup> units (1H = 1 data rate time<sup>Note</sup>).

Note: The rate time depends on the value specified in the timing parameter data rate setting register.

Control applied by the setting of this register includes the time for auto gain control (AGC) processing. Up to 2000 data rate time can be specified. The value of this register following a reset is 000DH.

**Figure 4-55 Format of CCA Time Register (CCATIME)**

Address: 00B3H, 00B2H After reset: 000DH R/W

Symbol	15	14	13	12	11	10	9	8
CCATIME (00B3H)	CCATIME15	CCATIME14	CCATIME13	CCATIME12	CCATIME11	CCATIME10	CCATIME9	CCATIME8
	7	6	5	4	3	2	1	0
(00B2H)	CCATIME7	CCATIME6	CCATIME5	CCATIME4	CCATIME3	CCATIME2	CCATIME1	CCATIME0
	CCATIME15 to CCATIME0		CCA time					

**Caution** The minimum value that can be specified in this register depends on the data rate.  
See the latest application note which specifies the recommended register settings for use with this product.

#### 4.2.49 IF frequency offset setting register 0 (BBIFOFST0)

The IF frequency offset 0 setting bits are used to set the offset value for the IF frequency. Specify a value in 2's complement representation. For example, 1H indicates 1 Hz. The specified value must be within the applicable range below.

- If the setting of the IF frequency setting bit is 0, that is, selecting 550 kHz: From -550 kHz to 1 MHz
- If the setting of the IF frequency setting bit is 1, that is, selecting 750 kHz: From -750 kHz to 1 MHz

The value of this register following a reset is 000000H.

**Figure 4-56 Format of IF Frequency Offset Setting Register 0 (BBIFOFST0)**

Address: 00B6H to 00B4H After reset: 000000H R/W

Symbol	23	22	21	20	19	18	17	16
BBIFOFST 0 (00B6H)	0	0	0	IFOFS0 SET20	IFOFS0 SET19	IFOFS0 SET18	IFOFS0 SET17	IFOFS0 SET16
	15	14	13	12	11	10	9	8
(00B5H)	IFOFS0 SET15	IFOFS0 SET14	IFOFS0 SET13	IFOFS0 SET12	IFOFS0 SET11	IFOFS0 SET10	IFOFS0 SET9	IFOFS0 SET8
	7	6	5	4	3	2	1	0
(00B4H)	IFOFS0 SET7	IFOFS0 SET6	IFOFS0 SET5	IFOFS0 SET4	IFOFS0 SET3	IFOFS0 SET2	IFOFS0 SET1	IFOFS0 SET0
	IFOFS0SET20 to IFOFS0SET0			IF frequency offset 0 setting				
	—			The offset value for the IF frequency				

**Caution** When writing to this register, set bits 23 to 21 to the value 0.

### 4.2.50 IF frequency offset setting register 1 (BBIFOFST1)

The IF frequency offset 1 setting bits are used to set the offset value for the IF frequency. Specify a value in 2's complement representation. For example, 1H indicates 1 Hz. The specified value must be within the applicable range below.

- If the setting of the IF frequency setting bit is 0, that is, selecting 550 kHz: From -550 kHz to 1 MHz
- If the setting of the IF frequency setting bit is 1, that is, selecting 750 kHz: From -750 kHz to 1 MHz

The value of this register following a reset is 000000H.

**Figure 4-57 Format of IF Frequency Offset Setting Register 1 (BBIFOFST1)**

Address: 00BAH to 00B8H After reset: 000000H R/W

Symbol	23	22	21	20	19	18	17	16
BBIFOFST 1 (00BAH)	0	0	0	IFOFS1 SET20	IFOFS1 SET19	IFOFS1 SET18	IFOFS1 SET17	IFOFS1 SET16
	15	14	13	12	11	10	9	8
(00B9H)	IFOFS1 SET15	IFOFS1 SET14	IFOFS1 SET13	IFOFS1 SET12	IFOFS1 SET11	IFOFS1 SET10	IFOFS1 SET9	IFOFS1 SET8
	7	6	5	4	3	2	1	0
(00B8H)	IFOFS1 SET7	IFOFS1 SET6	IFOFS1 SET5	IFOFS1 SET4	IFOFS1 SET3	IFOFS1 SET2	IFOFS1 SET1	IFOFS1 SET0
	IFOFS1SET20 to IFOFS1SET0			IF frequency offset 1 setting				
	—			The offset value for the IF frequency				

**Caution** When writing to this register, set bits 23 to 21 to the value 0.

### 4.2.51 Transmitted data counter register (BBTXCOUNT)

This register indicates the transmitted data counter value. The number of transmit data bytes that have been transferred from the transmission RAM to the transmitter can be read from this register. The value is cleared to 0 when packet transmission ends. Be sure to read data in the order from the lower-order byte to the higher-order byte because the higher-order three bits are stored in this register at the timing when the lower eight bits are read. When the value read from the lower-order byte at address 00BCH is 00H, re-read from the lower-order byte at the given address. Note that re-reading from the lower-order byte should be done before the counter has counted to 256 so that the value of the lower-order byte becomes 00H. The value of this register following a reset is 0000H.

**Figure 4-58 Format of Transmitted Data Counter Register (BBTXCOUNT)**

Address: 00BDH, 00BCH After reset: 0000H R

Symbol	15	14	13	12	11	10	9	8
BBTX COUNT (00BDH)	0	0	0	0	0	TRNCOUNT 10	TRNCOUNT 9	TRNCOUNT 8
	7	6	5	4	3	2	1	0
(00BCH)	TRNCOUNT 7	TRNCOUNT 6	TRNCOUNT 5	TRNCOUNT 4	TRNCOUNT 3	TRNCOUNT 2	TRNCOUNT 1	TRNCOUNT 0
	TRNCOUNT10 to TRNCOUNT0		Transmitted data counter value					

### 4.2.52 External device control register 0 (BBEXTCON0)

The CTX, CPS, and CSD signals can be output through GPIO port pins to control an external device such as a power amplifier. Output of the CTX, CPS, and CSD signals is enabled by the following bits in this register.

- Transmit CTX enable bit: CTX signal for transmission
- Receive CTX enable bit: CTX signal for reception
- Transmit CPS enable bit: CPS signal for transmission
- Receive CPS enable bit: CPS signal for reception
- Transmit CSD enable bit: CSD signal for transmission
- Receive CSD enable bit: CSD signal for reception

The output pins can be selected from among GPIO0 to GPIO12 by GPIO function selection registers 0 to 7.

The value of this register following a reset is 00H.

#### 4.2.52.1 CTX signal

Setting the transmit CTX enable bit to 1 drives the CTX signal high once the time specified in the CTX set timing register has elapsed since a transmission trigger is set. The signal is driven low once the time specified in the CTX clear timing register has elapsed since the completion of transmission. Setting the receive CTX enable bit to 1 drives the signal high once a receive trigger is set, and it is driven low upon completion of the reception.

#### 4.2.52.2 CPS signal

Setting the transmit CPS enable bit to 1 drives the CPS signal high once the time specified in the CPS set timing register has elapsed since a transmission trigger is set. The signal is driven low once the time specified in the CPS clear timing register has elapsed since the completion of transmission. Setting the receive CPS enable bit to 1 drives the signal high once a receive trigger is set, and it is driven low upon completion of the reception.

#### 4.2.52.3 CSD signal

Setting the transmit CSD enable bit to 1 drives the CSD signal high once the time specified in the CSD set timing register has elapsed since a transmission trigger is set. The signal is driven low once the time specified in the CSD clear timing register has elapsed since the completion of transmission. Setting the receive CSD enable bit to 1 drives the signal high once a receive trigger is set, and it is driven low upon completion of the reception.



Figure 4-59 Format of External Device Control Register 0 (BBEXTCON0)

Address: 00BEH After reset: 00H R/W

Symbol	7	6	5	4	3	2	1	0
BBEXT CON0	0	0	RXCSDEN	TXCSDEN	RXCPSEN	TXCPSEN	RXCTXEN	TXCTXEN

RXCSDEN	Receive CSD enable
0	Signal is disabled.
1	Signal is enabled.

TXCSDEN	Transmit CSD enable
0	Signal is disabled.
1	Signal is enabled.

RXCPSEN	Receive CPS enable
0	Signal is disabled.
1	Signal is enabled.

TXCPSEN	Transmit CPS enable
0	Signal is disabled.
1	Signal is enabled.

RXCTXEN	Receive CTX enable
0	Signal is disabled.
1	Signal is enabled.

TXCTXEN	Transmit CTX enable
0	Signal is disabled.
1	Signal is enabled.

**Caution** When writing to this register, set bits 7 and 6 to the value 0.

### 4.2.53 External device control register 1 (BBEXTCON1)

The CTX, CPS, and CSD inversion bits are used to invert the CTX, CPS, and CSD signals, respectively. The value of this register following a reset is 00H.

**Figure 4-60 Format of External Device Control Register 1 (BBEXTCON1)**

Address: 00BFH After reset: 00H R/W

Symbol	7	6	5	4	3	2	1	0
BBEXT CON1	0	0	0	0	0	CSDRVS	CPSRVS	CTXRVS

CSDRVS	CSD inversion
0	Normal operation.
1	Signal is inverted.

CPSRVS	CPS inversion
0	Normal operation.
1	Signal is inverted.

CTXRVS	CTX inversion
0	Normal operation.
1	Signal is inverted.

**Caution** When writing to this register, set bits 7 to 3 to the value 0.

#### 4.2.54 CTX set timing register (BBCTXSET)

This register is used to set the timing to drive the CTX signal for transmission to the high level when the transmit CTX enable bit is set (signal is enabled). The setting is possible in 1- $\mu$ s units (1H = 1  $\mu$ s). The value of this register following a reset is 0001H.

Figure 4-61 Format of CTX Set Timing Register (BBCTXSET)

Address: 00C1H, 00C0H After reset: 0001H R/W

Symbol	15	14	13	12	11	10	9	8
BBCTXSET (00C1H)	CTXSET15	CTXSET14	CTXSET13	CTXSET12	CTXSET11	CTXSET10	CTXSET9	CTXSET8
	7	6	5	4	3	2	1	0
(00C0H)	CTXSET7	CTXSET6	CTXSET5	CTXSET4	CTXSET3	CTXSET2	CTXSET1	CTXSET0
	CTXSET15 to CTXSET0		CTX set timing					
	—		Time for driving CTX for transmission to the high level					

### 4.2.55 CTX clear timing register (BBCTXCLR)

This register is used to set the timing to drive the CTX signal for transmission to the low level when the transmit CTX enable bit is set (signal is enabled). The setting is possible in 1- $\mu$ s units (1H = 1  $\mu$ s). The value of this register following a reset is 0001H.

**Figure 4-62 Format of CTX Clear Timing Register (BBCTXCLR)**

Address: 00C3H, 00C2H After reset: 0001H R/W

Symbol	15	14	13	12	11	10	9	8
BBCTXCLR (00C3H)	CTXCLR15	CTXCLR14	CTXCLR13	CTXCLR12	CTXCLR11	CTXCLR10	CTXCLR9	CTXCLR8
	7	6	5	4	3	2	1	0
(00C2H)	CTXCLR7	CTXCLR6	CTXCLR5	CTXCLR4	CTXCLR3	CTXCLR2	CTXCLR1	CTXCLR0

CTXCLR15 to CTXCLR0	CTX clear timing
—	Time for driving CTX for transmission to the low level

### 4.2.56 CPS set timing register (BBCPSSET)

This register is used to set the timing to drive the CPS signal for transmission to the high level when the transmit CPS enable bit is set (signal is enabled). The setting is possible in 1- $\mu$ s units (1H = 1  $\mu$ s). The value of this register following a reset is 0001H.

**Figure 4-63 Format of CPS Set Timing Register (BBCPSSET)**

Address: 00C5H, 00C4H After reset: 0001H R/W

Symbol	15	14	13	12	11	10	9	8
BBCPSSET (00C5H)	CPSSET15	CPSSET14	CPSSET13	CPSSET12	CPSSET11	CPSSET10	CPSSET9	CPSSET8
	7	6	5	4	3	2	1	0
(00C4H)	CPSSET7	CPSSET6	CPSSET5	CPSSET4	CPSSET3	CPSSET2	CPSSET1	CPSSET0
CPSSET15 to CPSSET0		CPS set timing						
—		These bits set the timing to drive the CPS signal for transmission to the high level.						

### 4.2.57 CPS clear timing register (BBCPSCLR)

This register is used to set the timing to drive the CPS signal for transmission to the low level when the transmit CPS enable bit is set (signal is enabled). The setting is possible in 1- $\mu$ s units (1H = 1  $\mu$ s). The value of this register following a reset is 0001H.

**Figure 4-64 Format of CPS Clear Timing Register (BBCPSCLR)**

Address: 00C7H, 00C6H After reset: 0001H R/W

Symbol	15	14	13	12	11	10	9	8
BBCPSCLR (00C7H)	CPSCLR15	CPSCLR14	CPSCLR13	CPSCLR12	CPSCLR11	CPSCLR10	CPSCLR9	CPSCLR8
	7	6	5	4	3	2	1	0
(00C6H)	CPSCLR7	CPSCLR6	CPSCLR5	CPSCLR4	CPSCLR3	CPSCLR2	CPSCLR1	CPSCLR0
	CPSCLR15 to CPSCLR0		CPS clear timing					
	—		These bits set the timing to drive the CPS signal for transmission to the low level.					

### 4.2.58 CSD set timing register (BBCSDSET)

This register is used to set the timing to drive the CSD signal for transmission to the high level when the transmit CSD enable bit is set (signal is enabled). The setting is possible in 1- $\mu$ s units (1H = 1  $\mu$ s). The value of this register following a reset is 0001H.

Figure 4-65 Format of CSD Set Timing Register (BBCSDSET)

Address: 00C9H, 00C8H After reset: 0001H R/W

Symbol	15	14	13	12	11	10	9	8
BBCSDSET (00C9H)	CSDSET15	CSDSET14	CSDSET13	CSDSET12	CSDSET11	CSDSET10	CSDSET9	CSDSET8
	7	6	5	4	3	2	1	0
(00C8H)	CSDSET7	CSDSET6	CSDSET5	CSDSET4	CSDSET3	CSDSET2	CSDSET1	CSDSET0
	CSDSET15 to CSDSET0		CSD set timing					
	—		These bits set the timing to drive the CSD signal for transmission to the high level.					

### 4.2.59 CSD clear timing register (BBCSDCLR)

This register is used to set the timing to drive the CSD signal for transmission to the low level when the transmit CSD enable bit is set (signal is enabled). The setting is possible in 1- $\mu$ s units (1H = 1  $\mu$ s). The value of this register following a reset is 0001H.

**Figure 4-66 Format of CSD Clear Timing Register (BBCSDCLR)**

Address: 00CBH, 00CAH After reset: 0001H R/W

Symbol	15	14	13	12	11	10	9	8
BBCSDCLR R (00CBH)	CSDCLR15	CSDCLR14	CSDCLR13	CSDCLR12	CSDCLR11	CSDCLR10	CSDCLR9	CSDCLR8
(00CAH)	7	6	5	4	3	2	1	0
	CSDCLR7	CSDCLR6	CSDCLR5	CSDCLR4	CSDCLR3	CSDCLR2	CSDCLR1	CSDCLR0
	CSDCLR15 to CSDCLR0		CSD clear timing					
	—		These bits set the timing to drive the CSD signal for transmission to the low level.					



#### 4.2.60 Number-of-received-byte interrupt comparison register (BBRCVINTCOMP)

This register is used to generate interrupts depending on the number of received bytes. An interrupt request is generated when the number of received bytes stored in the reception RAM reaches the specified number. When a number-of-receive-byte interrupt is generated while the address filter is enabled, the received data are not stored in the reception RAM until an address filter interrupt is generated. Set a value from 0001H to 07FFH in this register. The value of this register following a reset is 0010H.

**Figure 4-67 Format of Number-of-Received-Byte Interrupt Comparison Register (BBRCVINTCOMP)**

Address: 00D3H, 00D2H After reset: 0010H R/W

Symbol	15	14	13	12	11	10	9	8
BBRCVINT COMP (00D3H)	0	0	0	0	0	RCVINT COMP10	RCVINT COMP9	RCVINT COMP8
(00D2H)	7	6	5	4	3	2	1	0
	RCVINT COMP7	RCVINT COMP6	RCVINT COMP5	RCVINT COMP4	RCVINT COMP3	RCVINT COMP2	RCVINT COMP1	RCVINT COMP0
RCVINTCOMP10 to RCVINTCOMP0		Number of bytes that generates a number-of-receive-byte interrupt						

**Caution** When writing to this register, set bits 15 to 11 to the value 0.

### 4.2.61 Backoff period total number register (BBBOPTOTAL)

This register indicates the total number of backoff periods in CSMA-CA. The maximum value to be counted is FFFFH. The value of this register following a reset is 0000H.

**Figure 4-68 Format of Backoff Period Total Number Register (BBBOPTOTAL)**

Address: 00D5H, 00D4H After reset: 0000H R

Symbol	15	14	13	12	11	10	9	8
BBBOPTOTAL (00D5H)	BOPTOTAL	BOPTOTAL	BOPTOTAL	BOPTOTAL	BOPTOTAL	BOPTOTAL	BOPTOTAL	BOPTOTAL
	15	14	13	12	11	10	9	8
	7	6	5	4	3	2	1	0
(00D4H)	BOPTOTAL	BOPTOTAL	BOPTOTAL	BOPTOTAL	BOPTOTAL	BOPTOTAL	BOPTOTAL	BOPTOTAL
	7	6	5	4	3	2	1	0
	BOPTOTAL15 to BOPTOTAL0		Total number of backoff periods					

### 4.2.62 CCA total number register (BBCCATOTAL)

This register indicates the total number of CCA operations in CSMA-CA. The maximum value to be counted is FFH. The value of this register following a reset is 00H.

**Figure 4-69 Format of CCA Total Number Register (BBCCATOTAL)**

Address: 00D6H After reset: 00H R

Symbol	7	6	5	4	3	2	1	0
BBCCATOTAL	CCATOTAL	CCATOTAL	CCATOTAL	CCATOTAL	CCATOTAL	CCATOTAL	CCATOTAL	CCATOTAL
	7	6	5	4	3	2	1	0
CCATOTAL7 to CCATOTAL0		Total number of CCA operations						

#### 4.2.63 Address filter extension address control register (BBADFCON)

The PAN coordinator 2 bit selects whether the received address matches the PAN coordinator address as an address filter condition for the second address. The frame pending 2 setting bit sets the value of the frame pending bit in the ACK data to be returned for the second address. The first address filter match monitor bit and second address filter match monitor bit are used to monitor the first address match and second address match, respectively. The values corresponding to the save bank specified by the receive data save bank select bit is read from these registers. When address extension is disabled by the address filter address extension bit, the values in the first and second address filter match monitor bits are invalid. When address extension is enabled by the address filter address extension bit, the values in the first and second address filter match monitor bits are invalid under the following conditions.

- Frame version: 00 or 01
- Frame type: Beacon frame
- No destination PAN ID or destination address
- The source PAN ID matches the value of either of the PAN identifier register 0 or 1, or either of the value of the PAN identifier register 0 or 1 is FFFFH.
- PANCORD bit = 0

The value of this register following a reset is 00H.

**Figure 4-70 Format of Address Filter Extension Address Control Register (BBADFCON)**Address: 00DFH After reset: 00H R/W<sup>Note</sup>

Symbol	7	6	5	4	3	2	1	0
BBADF CON	0	0	0	0	ADFMONI2	ADFMONI1	FLMPEND2	PANCORD2

ADFMONI2	Second address filter match monitor
0	Second address mismatch
1	Second address match

ADFMONI1	First address filter match monitor
0	First address mismatch
1	First address match

FLMPEND2	Frame pending 2 setting
0	Frame pending bit = 0
1	Frame pending bit = 1

PANCORD2	PAN coordinator 2
0	The address is not for the PAN coordinator.
1	The address is for the PAN coordinator.

**Note:** Bits 3 and 2 are read-only.**Caution** When writing to this register, set bits 7 to 4 to the value 0.

#### 4.2.64 PAN identifier register 1 (BBPANID1)

This register is used to set the PAN identifier as a condition for filtering of the second address. It consists of 16 bits and the specified value is compared with the received PAN identifier to detect an address match. Set a value from 0000H to FFFFH in this register. The value of this register following a reset is FFFFH.

**Figure 4-71 Format of PAN Identifier Register 1 (BBPANID1)**

Address: 00E1H, 00E0H After reset: FFFFH R/W

Symbol	15	14	13	12	11	10	9	8
BBPANID1 (00E1H)	PANID115	PANID114	PANID113	PANID112	PANID111	PANID110	PANID19	PANID18
	7	6	5	4	3	2	1	0
(00E0H)	PANID17	PANID16	PANID15	PANID14	PANID13	PANID12	PANID11	PANID10
	PANID115 to PANID10		PAN identifier					

### 4.2.65 Short address register 1 (BBSHORTAD1)

This register is used to set the short address as a condition for filtering of the second address. It consists of 16 bits and the specified value is compared with the received short address to detect an address match. Set a value from 0000H to FFFFH in this register. The value of this register following a reset is FFFFH.

**Figure 4-72 Format of Short Address Register 1 (BBSHORTAD1)**

Address: 00E3H, 00E2H After reset: FFFFH R/W

Symbol	15	14	13	12	11	10	9	8
BBSHORT AD1 (00E3H)	SHORTAD1 15	SHORTAD1 14	SHORTAD1 13	SHORTAD1 12	SHORTAD1 11	SHORTAD1 10	SHORTAD1 9	SHORTAD1 8
	7	6	5	4	3	2	1	0
(00E2H)	SHORTAD1 7	SHORTAD1 6	SHORTAD1 5	SHORTAD1 4	SHORTAD1 3	SHORTAD1 2	SHORTAD1 1	SHORTAD1 0
	SHORTAD115 to SHORTAD10		Short address					

#### 4.2.66 Extended address registers 1 (BBEXTENDAD10 to BBEXTENDAD13)

These registers are used to set the extended address as a condition for filtering of the second address. Four 16-bit registers are provided to specify a 64-bit address and the specified value is compared with the received extended address to detect an address match. Set a value from 0000H to FFFFH in these registers. The value of these registers following a reset is 0000H.

**Figure 4-73 Format of Extended Address Registers 1 (BBEXTENDAD10 to BBEXTENDAD13) (1/2)**

Address: 00EBH, 00EAH After reset: 0000H R/W

Symbol	15	14	13	12	11	10	9	8
BBEXTEN DAD13 (00EBH)	EXTENDAD 1315	EXTENDAD 1314	EXTENDAD 1313	EXTENDAD 1312	EXTENDAD 1311	EXTENDAD 1310	EXTENDAD 139	EXTENDAD 138
	7	6	5	4	3	2	1	0
(00EAH)	EXTENDAD 137	EXTENDAD 136	EXTENDAD 135	EXTENDAD 134	EXTENDAD 133	EXTENDAD 132	EXTENDAD 131	EXTENDAD 130
EXTENDAD1315 to EXTENDAD130		Bits 63 to 48 of extended address						

Address: 00E9H, 00E8H After reset: 0000H R/W

Symbol	15	14	13	12	11	10	9	8
BBEXTEN DAD12 (00E9H)	EXTENDAD 1215	EXTENDAD 1214	EXTENDAD 1213	EXTENDAD 1212	EXTENDAD 1211	EXTENDAD 1210	EXTENDAD 129	EXTENDAD 128
	7	6	5	4	3	2	1	0
(00E8H)	EXTENDAD 127	EXTENDAD 126	EXTENDAD 125	EXTENDAD 124	EXTENDAD 123	EXTENDAD 122	EXTENDAD 121	EXTENDAD 120
EXTENDAD1215 to EXTENDAD120		Bits 47 to 32 of extended address						



Figure 4-74 Format of Extended Address Registers 1 (BBEXTENDAD10 to BBEXTENDAD13) (2/2)

Address: 00E7H, 00E6H After reset: 0000H R/W

Symbol	15	14	13	12	11	10	9	8
BBEXTEN DAD11 (00E7H)	EXTENDAD 1115	EXTENDAD 1114	EXTENDAD 1113	EXTENDAD 1112	EXTENDAD 1111	EXTENDAD 1110	EXTENDAD 119	EXTENDAD 118
	7	6	5	4	3	2	1	0
(00E6H)	EXTENDAD 117	EXTENDAD 116	EXTENDAD 115	EXTENDAD 114	EXTENDAD 113	EXTENDAD 112	EXTENDAD 111	EXTENDAD 110
EXTENDAD1115 to EXTENDAD110		Bits 31 to 16 of extended address						

Address: 00E5H, 00E4H After reset: 0000H R/W

Symbol	15	14	13	12	11	10	9	8
BBEXTEN DAD10 (00E5H)	EXTENDAD 1015	EXTENDAD 1014	EXTENDAD 1013	EXTENDAD 1012	EXTENDAD 1011	EXTENDAD 1010	EXTENDAD 109	EXTENDAD 108
	7	6	5	4	3	2	1	0
(00E4H)	EXTENDAD 107	EXTENDAD 106	EXTENDAD 105	EXTENDAD 104	EXTENDAD 103	EXTENDAD 102	EXTENDAD 101	EXTENDAD 100
EXTENDAD1015 to EXTENDAD100		Bits 15 to 0 of extended address						

### 4.2.67 Reception timeout register (BBTIMEOUT)

This register is used to set the time until a timeout occurs when ACK is not returned (PHR reception is not started) while the automatic receive mode with the timeout function is enabled. This register consists of 12 bits. Set a value from 0001H to 0FFFH in this register. The setting is possible in 1- $\mu$ s units (1H = 1  $\mu$ s). The value of this register following a reset is 07D0H, that is, 2 ms.

**Figure 4-75 Format of Reception Timeout Register (BBTIMEOUT)**

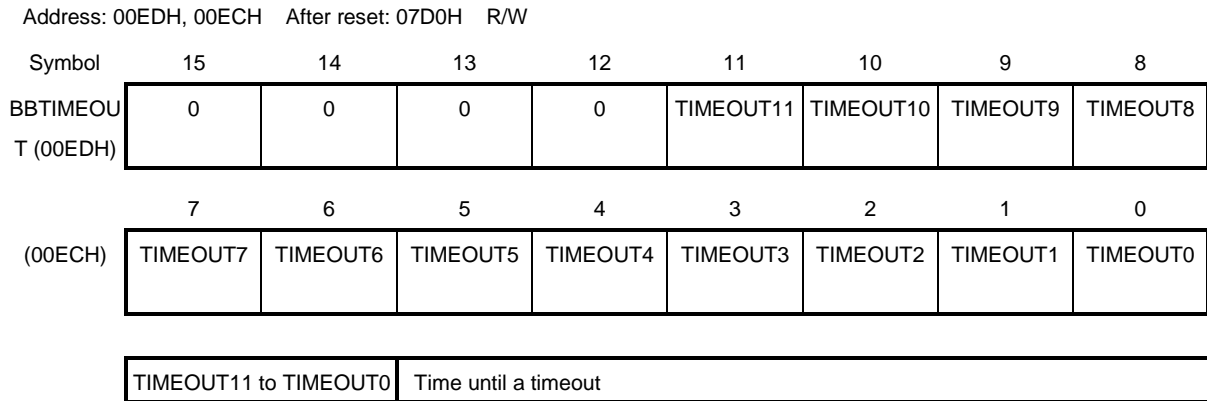

**Caution** When writing to this register, set bits 15 to 12 to the value 0.

#### 4.2.68 INTOUT mode register (BBINTOUTMODE)

The INTOUT0 output sense switching bit can select the interrupt sense (high or low level) of the interrupt output from the port pin selected as the INTOUT0 output pin. The following interrupt source flags are automatically cleared upon completion of reception by setting the reception completion synchronized clearing bit.

- Frame length
- Address filtering
- Start reception
- AGC completion
- Preamble detection
- Carrier sense

The INTREQ0 selection bit can select whether the CSMA-CA completion interrupt or the CCA completion interrupt is the interrupt source assigned to the following bits.

- Respective bits 4 in the registers at 00F8H, 0100H, and 0108H

The INTREQ1 selection bit can select the frame length interrupt or the address filtering interrupt as the interrupt source assigned to the following bits.

- Respective bits 4 in the registers at 00F9H, 0101H, and 0109H
- Respective bits 5 in the registers at 00FAH, 0102H, and 010AH
- Respective bits 5 in the registers at 00FBH, 0103H, and 010BH

The INTREQ2 selection bit can select the CCA clearance interrupt or the reception canceled interrupt as the interrupt source assigned to the following bits.

- Respective bits 2 in the registers at 00FAH, 0102H, and 010AH

The following interrupt source flags are automatically cleared upon cancellation of reception if the setting of the reception canceling synchronized clearing bit is 1.

- Bank 0 reception completion
- Bank 1 reception completion
- Frame length
- Address filtering
- Start reception
- Number of received bytes
- AGC completion
- Preamble detection
- Carrier sense

The value of this register following a reset is 00H.

Figure 4-76 Format of INTOUT Mode Register (BBINTOUTMODE)

Address: 00F2H After reset: 00H R/W

Symbol	7	6	5	4	3	2	1	0
BBINTOUT MODE	RCVCANCE LCLR	INTREQ2 SEL	INTREQ1 SEL	INTREQ0 SEL	RCVFINCLR	0	0	INTOUT0 SEL

RCVCANCE LCLR	Reception canceling synchronized clearing
0	Interrupt source flags are not automatically cleared upon cancellation of reception.
1	Interrupt source flags are automatically cleared upon cancellation of reception.

INTREQ2 SEL	INTREQ2 selection
0	The CCA clearance interrupt is selected.
1	The reception canceled interrupt is selected.

INTREQ1 SEL	INTREQ1 selection
0	The frame length interrupt is selected.
1	The address filtering interrupt is selected.

INTREQ0 SEL	INTREQ0 selection
0	The CSMA-CA completion interrupt is selected.
1	The CCA completion interrupt is selected.

RCVFINCLR	Reception completion synchronized clearing
0	Interrupt source flags are not automatically cleared upon completion of reception.
1	Interrupt source flags are automatically cleared upon completion of reception.

INTOUT0 SEL	INTOUT0 output sense switching
0	High level is an interrupt request.
1	Low level is an interrupt request.

**Caution** When writing to this register, set bits 2 and 1 to the value 0.

#### 4.2.69 INTOUT0 interrupt source register 0 (BBINT0REQ0)

Upon the generation of an interrupt request due to a given interrupt source condition being satisfied while the corresponding interrupt request is enabled, the corresponding interrupt source flag is set to 1 to indicate generation of the interrupt request. Reading this bit only clears it to 0 after it has been read as 1. Dummy-read the bit to clear it because it is not writable. When the setting of at least one of the interrupt source flags in the INTOUT0 interrupt source registers 0 to 7 is 1, and the generation of the corresponding interrupt request is enabled, the 8 bytes of the INTOUT0 interrupt source registers 0 to 7 must be read consecutively with the SEN pin remaining at the low level. The values of these registers following a reset are undefined.

**Figure 4-77 Format of INTOUT0 Interrupt Source Register 0 (BBINT0REQ0) (1/2)**

Address: 00F4H After reset: XXH R

Symbol	7	6	5	4	3	2	1	0
BBINT0	CSMA	FSYNC	TRN1	TRN0	CAL	TIM2	TIM1	TIM0
REQ0	INTREQ	INTREQ	INTREQ	INTREQ	INTREQ	INTREQ	INTREQ	INTREQ

CSMA INTREQ	CSMA-CA completion interrupt source flag
0	No interrupt request has been generated.
1	An interrupt request has been generated.

FSYNC INTREQ	Frame synchronization transmission completion interrupt source flag
0	No interrupt request has been generated.
1	An interrupt request has been generated.

TRN1 INTREQ	Bank 1 transmission completion interrupt source flag
0	No interrupt request has been generated.
1	An interrupt request has been generated.

TRN0 INTREQ	Bank 0 transmission completion interrupt source flag
0	No interrupt request has been generated.
1	An interrupt request has been generated.

CAL INTREQ	Calibration completion interrupt source flag
0	No interrupt request has been generated.
1	An interrupt request has been generated.

Figure 4-78 Format of INTOUT0 Interrupt Source Register 0 (BBINT0REQ0) (2/2)

TIM2 INTREQ	Timer comparison 2 interrupt source flag
0	No interrupt request has been generated.
1	An interrupt request has been generated.

TIM1 INTREQ	Timer comparison 1 interrupt source flag
0	No interrupt request has been generated.
1	An interrupt request has been generated.

TIM0 INTREQ	Timer comparison 0 interrupt source flag
0	No interrupt request has been generated.
1	An interrupt request has been generated.

#### 4.2.70 INTOUT0 interrupt source register 1 (BBINT0REQ1)

Upon the generation of an interrupt request due to a given interrupt source condition being satisfied while the corresponding interrupt request is enabled, the corresponding interrupt source flag is set to 1 to indicate generation of the interrupt request. Reading this bit only clears it to 0 after it has been read as 1. Dummy-read the bit to clear it because it is not writable. When the setting of at least one of the interrupt source flags in the INTOUT0 interrupt source registers 0 to 7 is 1, and the generation of the corresponding interrupt request is enabled, the 8 bytes of the INTOUT0 interrupt source registers 0 to 7 must be read consecutively with the SEN pin remaining at the low level. The values of these registers following a reset are undefined.

**Figure 4-79 Format of INTOUT0 Interrupt Source Register 1 (BBINT0REQ1) (1/2)**

Address: 00F5H After reset: XXH R

Symbol	7	6	5	4	3	2	1	0
BBINT0	TRNFIN	RCVLVL	MODESW	ROVR	ADRS	FL	RCV1	RCV0
REQ1	INTREQ	INTREQ	INTREQ	INTREQ	INTREQ	INTREQ	INTREQ	INTREQ

TRNFIN INTREQ	Frame transmission completion interrupt source flag
0	No interrupt request has been generated.
1	An interrupt request has been generated.

RCVLVL INTREQ	Reception level interrupt source flag
0	No interrupt request has been generated.
1	An interrupt request has been generated.

MODESW INTREQ	Mode switch reception completion interrupt source flag
0	No interrupt request has been generated.
1	An interrupt request has been generated.

ROVR INTREQ	Reception overrun interrupt source flag
0	No interrupt request has been generated.
1	An interrupt request has been generated.

ADRS INTREQ	Address filtering interrupt source flag
0	No interrupt request has been generated.
1	An interrupt request has been generated.

Figure 4-80 Format of INTOUT0 Interrupt Source Register 1 (BBINT0REQ1) (2/2)

FL INTREQ	Frame length interrupt source flag
0	No interrupt request has been generated.
1	An interrupt request has been generated.

RCV1 INTREQ	Bank 1 reception completion interrupt source flag
0	No interrupt request has been generated.
1	An interrupt request has been generated.

RCV0 INTREQ	Bank 0 reception completion interrupt source flag
0	No interrupt request has been generated.
1	An interrupt request has been generated.



### 4.2.71 INTOUT0 interrupt source register 2 (BBINT0REQ2)

Upon the generation of an interrupt request due to a given interrupt source condition being satisfied while the corresponding interrupt request is enabled, the corresponding interrupt source flag is set to 1 to indicate generation of the interrupt request. Reading this bit only clears it to 0 after it has been read as 1. Dummy-read the bit to clear it because it is not writable. When the setting of at least one of the interrupt source flags in the INTOUT0 interrupt source registers 0 to 7 is 1, and the generation of the corresponding interrupt request is enabled, the 8 bytes of the INTOUT0 interrupt source registers 0 to 7 must be read consecutively with the SEN pin remaining at the low level. The values of these registers following a reset are undefined.

**Figure 4-81 Format of INTOUT0 Interrupt Source Register 2 (BBINT0REQ2) (1/2)**

Address: 00F6H After reset: XXH R

Symbol	7	6	5	4	3	2	1	0
BBINT0	PREAMBL	CCA	AGC	RCVBYTE	RCVFIN	RCVSTA	TRNSTART	TRNBYTE
REQ2	INTREQ	INTREQ	INTREQ	INTREQ	INTREQ	INTREQ	INTREQ	INTREQ

PREAMBL INTREQ	Preamble detection interrupt source flag
0	No interrupt request has been generated.
1	An interrupt request has been generated.

CCA INTREQ	CCA completion interrupt source flag
0	No interrupt request has been generated.
1	An interrupt request has been generated.

AGC INTREQ	AGC completion interrupt source flag
0	No interrupt request has been generated.
1	An interrupt request has been generated.

RCVBYTE INTREQ	Number of received bytes interrupt source flag
0	No interrupt request has been generated.
1	An interrupt request has been generated.

RCVFIN INTREQ	Frame reception completion interrupt source flag
0	No interrupt request has been generated.
1	An interrupt request has been generated.

Figure 4-82 Format of INTOUT0 Interrupt Source Register 2 (BBINT0REQ2) (2/2)

RCVSTA INTREQ	Reception start interrupt source flag
0	No interrupt request has been generated.
1	An interrupt request has been generated.

TRNSTAR TINTREQ	Transmission start interrupt source flag
0	No interrupt request has been generated.
1	An interrupt request has been generated.

TRNBYTE INTREQ	Number of transmitted bytes interrupt source flag
0	No interrupt request has been generated.
1	An interrupt request has been generated.

### 4.2.72 INTOUT0 interrupt source register 3 (BBINT0REQ3)

Upon the generation of an interrupt request due to a given interrupt source condition being satisfied while the corresponding interrupt request is enabled, the corresponding interrupt source flag is set to 1 to indicate generation of the interrupt request. Reading this bit only clears it to 0 after it has been read as 1. Dummy-read the bit to clear it because it is not writable. When the setting of at least one of the interrupt source flags in the INTOUT0 interrupt source registers 0 to 7 is 1, and the generation of the corresponding interrupt request is enabled, the 8 bytes of the INTOUT0 interrupt source registers 0 to 7 must be read consecutively with the SEN pin remaining at the low level. The values of these registers following a reset are undefined.

**Figure 4-83 Format of INTOUT0 Interrupt Source Register 3 (BBINT0REQ3) (1/2)**

Address: 00F7H After reset: XXH R

Symbol	7	6	5	4	3	2	1	0
BBINT0	CANCEL	X	X	TRNUNDRR	RCVTOUT	CCACLR	CCALIMIT	CS
REQ3	INTREQ			UNINTREQ	INTREQ	INTREQ	INTREQ	INTREQ

CANCEL INTREQ	Reception canceled interrupt source flag
0	No interrupt request has been generated.
1	An interrupt request has been generated.

TRNUNDRR UNINTREQ	Transmission underrun interrupt source flag
0	No interrupt request has been generated.
1	An interrupt request has been generated.

RCVTOUT INTREQ	Automatic reception timeout interrupt source flag
0	No interrupt request has been generated.
1	An interrupt request has been generated.

CCACLR INTREQ	CCA clearance interrupt source flag
0	No interrupt request has been generated.
1	An interrupt request has been generated.

CCALIMIT INTREQ	CCA limitation interrupt source flag
0	No interrupt request has been generated.
1	An interrupt request has been generated.

Figure 4-84 Format of INTOUT0 Interrupt Source Register 3 (BBINT0REQ3) (2/2)

CS INTREQ	Carrier sense interrupt source flag
0	No interrupt request has been generated.
1	An interrupt request has been generated.

### 4.2.73 INTOUT0 interrupt source register 4 (BBINT0REQ4)

Upon the generation of an interrupt request due to a given interrupt source condition being satisfied while the corresponding interrupt request is enabled, the corresponding interrupt source flag is set to 1 to indicate generation of the interrupt request. Reading this bit only clears it to 0 after it has been read as 1. Dummy-read the bit to clear it because it is not writable. When the setting of at least one of the interrupt source flags in the INTOUT0 interrupt source registers 0 to 7 is 1, and the generation of the corresponding interrupt request is enabled, the 8 bytes of the INTOUT0 interrupt source registers 0 to 7 must be read consecutively with the SEN pin remaining at the low level. The values of these registers following a reset are undefined.

Figure 4-85 Format of INTOUT0 Interrupt Source Register 4 (BBINT0REQ4) (1/2)

Address: 00F8H After reset: XXH R

Symbol	7	6	5	4	3	2	1	0
BBINT0	TRNFIN	TRNFSYNC	TRNSTART	CSMA	TRNUNDRR	TRNBYTE	TRN1	TRN0
REQ4	INTREQ	INTREQ	INTREQ	INTREQ	UNINTREQ	INTREQ	INTREQ	INTREQ

TRNFIN INTREQ	Frame transmission completion interrupt source flag
0	No interrupt request has been generated.
1	An interrupt request has been generated.

TRNFSYNC INTREQ	Frame synchronization transmission completion interrupt source flag
0	No interrupt request has been generated.
1	An interrupt request has been generated.

TRNSTART INTREQ	Transmission start interrupt source flag
0	No interrupt request has been generated.
1	An interrupt request has been generated.

CSMA INTREQ	CSMA-CA completion or CCA completion interrupt source flag
0	No interrupt request has been generated.
1	An interrupt request has been generated.

TRNUNDRR UNINTREQ	Transmission underrun interrupt source flag
0	No interrupt request has been generated.
1	An interrupt request has been generated.

Figure 4-86 Format of INTOUT0 Interrupt Source Register 4 (BBINT0REQ4) (2/2)

TRNBYTE INTREQ	Number of transmitted bytes interrupt source flag
0	No interrupt request has been generated.
1	An interrupt request has been generated.

TRN1 INTREQ	Bank 1 transmission completion interrupt source flag
0	No interrupt request has been generated.
1	An interrupt request has been generated.

TRN0 INTREQ	Bank 0 transmission completion interrupt source flag
0	No interrupt request has been generated.
1	An interrupt request has been generated.

#### 4.2.74 INTOUT0 interrupt source register 5 (BBINT0REQ5)

Upon the generation of an interrupt request due to a given interrupt source condition being satisfied while the corresponding interrupt request is enabled, the corresponding interrupt source flag is set to 1 to indicate generation of the interrupt request. Reading this bit only clears it to 0 after it has been read as 1. Dummy-read the bit to clear it because it is not writable. When the setting of at least one of the interrupt source flags in the INTOUT0 interrupt source registers 0 to 7 is 1, and the generation of the corresponding interrupt request is enabled, the 8 bytes of the INTOUT0 interrupt source registers 0 to 7 must be read consecutively with the SEN pin remaining at the low level. The values of these registers following a reset are undefined.

**Figure 4-87 Format of INTOUT0 Interrupt Source Register 5 (BBINT0REQ5) (1/2)**

Address: 00F9H After reset: XXH R

Symbol	7	6	5	4	3	2	1	0
BBINT0	RCVTOUT	RCVLVL	RCVFIN	FL	RCVSTART	PREAMBL	CS	AGC
REQ5	INTREQ	INTREQ	INTREQ	INTREQ	INTREQ	INTREQ	INTREQ	INTREQ

RCVTOUT INTREQ	Automatic reception timeout interrupt source flag
0	No interrupt request has been generated.
1	An interrupt request has been generated.

RCVLVL INTREQ	Reception level interrupt source flag
0	No interrupt request has been generated.
1	An interrupt request has been generated.

RCVFIN INTREQ	Frame reception completion interrupt source flag
0	No interrupt request has been generated.
1	An interrupt request has been generated.

FL INTREQ	Frame length or address filtering interrupt source flag
0	No interrupt request has been generated.
1	An interrupt request has been generated.

RCVSTART INTREQ	Reception start interrupt source flag
0	No interrupt request has been generated.
1	An interrupt request has been generated.

Figure 4-88 Format of INTOUT0 Interrupt Source Register 5 (BBINT0REQ5) (2/2)

PREAMBL INTREQ	Preamble detection interrupt source flag
0	No interrupt request has been generated.
1	An interrupt request has been generated.

CS INTREQ	Carrier sense interrupt source flag
0	No interrupt request has been generated.
1	An interrupt request has been generated.

AGC INTREQ	AGC completion interrupt source flag
0	No interrupt request has been generated.
1	An interrupt request has been generated.



### 4.2.75 INTOUT0 interrupt source register 6 (BBINT0REQ6)

Upon the generation of an interrupt request due to a given interrupt source condition being satisfied while the corresponding interrupt request is enabled, the corresponding interrupt source flag is set to 1 to indicate generation of the interrupt request. Reading this bit only clears it to 0 after it has been read as 1. Dummy-read the bit to clear it because it is not writable. When the setting of at least one of the interrupt source flags in the INTOUT0 interrupt source registers 0 to 7 is 1, and the generation of the corresponding interrupt request is enabled, the 8 bytes of the INTOUT0 interrupt source registers 0 to 7 must be read consecutively with the SEN pin remaining at the low level. The values of these registers following a reset are undefined.

**Figure 4-89 Format of INTOUT0 Interrupt Source Register 6 (BBINT0REQ6) (1/2)**

Address: 00FAH After reset: XXH R

Symbol	7	6	5	4	3	2	1	0
BBINT0	RCVLVL	RCVFIN	FL	RCVSTART	CCALIMIT	CCACLR	CCA	CSMA
REQ6	INTREQ	INTREQ	INTREQ	INTREQ	INTREQ	INTREQ	INTREQ	INTREQ

RCVLVL INTREQ	Reception level interrupt source flag
0	No interrupt request has been generated.
1	An interrupt request has been generated.

RCVFIN INTREQ	Frame reception completion interrupt source flag
0	No interrupt request has been generated.
1	An interrupt request has been generated.

FL INTREQ	Frame length or address filtering interrupt source flag
0	No interrupt request has been generated.
1	An interrupt request has been generated.

RCVSTART INTREQ	Reception start interrupt source flag
0	No interrupt request has been generated.
1	An interrupt request has been generated.

CCALIMIT INTREQ	CCA limitation interrupt source flag
0	No interrupt request has been generated.
1	An interrupt request has been generated.

Figure 4-90 Format of INTOUT0 Interrupt Source Register 6 (BBINT0REQ6) (2/2)

CCACLR INTREQ	CCA clearance or reception canceled interrupt source flag
0	No interrupt request has been generated.
1	An interrupt request has been generated.

CCA INTREQ	CCA completion interrupt source flag
0	No interrupt request has been generated.
1	An interrupt request has been generated.

CSMA INTREQ	CSMA-CA completion interrupt source flag
0	No interrupt request has been generated.
1	An interrupt request has been generated.

#### 4.2.76 INTOUT0 interrupt source register 7 (BBINT0REQ7)

Upon the generation of an interrupt request due to a given interrupt source condition being satisfied while the corresponding interrupt request is enabled, the corresponding interrupt source flag is set to 1 to indicate generation of the interrupt request. Reading this bit only clears it to 0 after it has been read as 1. Dummy-read the bit to clear it because it is not writable. When the setting of at least one of the interrupt source flags in the INTOUT0 interrupt source registers 0 to 7 is 1, and the generation of the corresponding interrupt request is enabled, the 8 bytes of the INTOUT0 interrupt source registers 0 to 7 must be read consecutively with the SEN pin remaining at the low level. The values of these registers following a reset are undefined.

Figure 4-91 Format of INTOUT0 Interrupt Source Register 7 (BBINT0REQ7) (1/2)

Address: 00FBH After reset: XXH R

Symbol	7	6	5	4	3	2	1	0
BBINT0	RCVLVL	RCVFI	FL	RCVSTART	ROVR	RCVBYTE	RCV1	RCV0
REQ7	INTREQ	NINTREQ	INTREQ	INTREQ	INTREQ	INTREQ	INTREQ	INTREQ

RCVLVL	Reception level interrupt source flag
INTREQ	
0	No interrupt request has been generated.
1	An interrupt request has been generated.

RCVFIN	Frame reception completion interrupt source flag
INTREQ	
0	No interrupt request has been generated.
1	An interrupt request has been generated.

FL	Frame length or address filtering interrupt source flag
INTREQ	
0	No interrupt request has been generated.
1	An interrupt request has been generated.

RCVSTART	Reception start interrupt source flag
INTREQ	
0	No interrupt request has been generated.
1	An interrupt request has been generated.

ROVR	Reception overrun interrupt source flag
INTREQ	
0	No interrupt request has been generated.
1	An interrupt request has been generated.

Figure 4-92 Format of INTOUT0 Interrupt Source Register 7 (BBINT0REQ7) (2/2)

RCVBYTE INTREQ	Number of received bytes interrupt source flag
0	No interrupt request has been generated.
1	An interrupt request has been generated.

RCV1 INTREQ	Bank 1 reception completion interrupt source flag
0	No interrupt request has been generated.
1	An interrupt request has been generated.

RCV0 INTREQ	Bank 0 reception completion interrupt source flag
0	No interrupt request has been generated.
1	An interrupt request has been generated.

### 4.2.77 INTOUT0 interrupt enable register 0 (BBINT0EN0)

An interrupt enable bit enables the output of an interrupt signal on the GPIO port pin selected as the INTOUT0 output pin upon the generation of the corresponding interrupt request. To enable the output of an interrupt signal, set the corresponding interrupt enable bit. The value of this register following a reset is 00H.

Figure 4-93 Format of INTOUT0 Interrupt Enable Register 0 (BBINT0EN0) (1/2)

Address: 00FCH After reset: 00H R/W

Symbol	7	6	5	4	3	2	1	0
BBINT0	CSMA	FSYNC	TRN1	TRN0	CAL	TIM2	TIM1	TIM0
EN0	INTEN	INTEN	INTEN	INTEN	INTEN	INTEN	INTEN	INTEN

CSMA INTEN	CSMA-CA completion interrupt enable
0	Interrupt signal output is disabled.
1	Interrupt signal output is enabled.

FSYNC INTEN	Frame synchronization transmission completion interrupt enable
0	Interrupt signal output is disabled.
1	Interrupt signal output is enabled.

TRN1 INTEN	Bank 1 transmission completion interrupt enable
0	Interrupt signal output is disabled.
1	Interrupt signal output is enabled.

TRN0 INTEN	Bank 0 transmission completion interrupt enable
0	Interrupt signal output is disabled.
1	Interrupt signal output is enabled.

CAL INTEN	Calibration completion interrupt enable
0	Interrupt signal output is disabled.
1	Interrupt signal output is enabled.

TIM2 INTEN	Timer comparison 2 interrupt enable
0	Interrupt signal output is disabled.
1	Interrupt signal output is enabled.

Figure 4-94 Format of INTOUT0 Interrupt Enable Register 0 (BBINT0EN0) (2/2)

TIM1 INTEN	Timer comparison 1 interrupt enable
0	Interrupt signal output is disabled.
1	Interrupt signal output is enabled.

TIM0 INTEN	Timer comparison 0 interrupt enable
0	Interrupt signal output is disabled.
1	Interrupt signal output is enabled.

### 4.2.78 INTOUT0 interrupt enable register 1 (BBINT0EN1)

An interrupt enable bit enables the output of an interrupt signal on the GPIO port pin selected as the INTOUT0 output pin upon the generation of the corresponding interrupt request. To enable the output of an interrupt signal, set the corresponding interrupt enable bit. The value of this register following a reset is 00H.

Figure 4-95 Format of INTOUT0 Interrupt Enable Register 1 (BBINT0EN1) (1/2)

Address: 00FDH After reset: 00H R/W

Symbol	7	6	5	4	3	2	1	0
BBINT0	TRNFIN	RCVLVL	MODESW	ROVR	ADRS	FL	RCV1	RCV0
EN1	INTEN	INTEN	INTEN	INTEN	INTEN	INTEN	INTEN	INTEN

TRNFIN INTEN	Frame transmission completion interrupt enable
0	Interrupt signal output is disabled.
1	Interrupt signal output is enabled.

RCVLVL INTEN	Reception level interrupt enable
0	Interrupt signal output is disabled.
1	Interrupt signal output is enabled.

MODESW INTEN	Mode switch reception completion interrupt enable
0	Interrupt signal output is disabled.
1	Interrupt signal output is enabled.

ROVR INTEN	Reception overrun interrupt enable
0	Interrupt signal output is disabled.
1	Interrupt signal output is enabled.

ADRS INTEN	Address filtering interrupt enable
0	Interrupt signal output is disabled.
1	Interrupt signal output is enabled.

FL INTEN	Frame length interrupt enable
0	Interrupt signal output is disabled.
1	Interrupt signal output is enabled.

Figure 4-96 Format of INTOUT0 Interrupt Enable Register 1 (BBINT0EN1) (2/2)

RCV1 INTEN	Bank 1 reception completion interrupt enable
0	Interrupt signal output is disabled.
1	Interrupt signal output is enabled.

RCV0 INTEN	Bank 0 reception completion interrupt enable
0	Interrupt signal output is disabled.
1	Interrupt signal output is enabled.



### 4.2.79 INTOUT0 interrupt enable register 2 (BBINT0EN2)

An interrupt enable bit enables the output of an interrupt signal on the GPIO port pin selected as the INTOUT0 output pin upon the generation of the corresponding interrupt request. To enable the output of an interrupt signal, set the corresponding interrupt enable bit. The value of this register following a reset is 00H.

Figure 4-97 Format of INTOUT0 Interrupt Enable Register 2 (BBINT0EN2) (1/2)

Address: 00FEH After reset: 00H R/W

Symbol	7	6	5	4	3	2	1	0
BBINT0	PREAMBL	CCA	AGC	RCVBYTE	RCVFIN	RCVSTA	TRNSTART	TRNBYTE
EN2	INTEN	INTEN	INTEN	INTEN	INTEN	INTEN	INTEN	INTEN

PREAMBL INTEN	Preamble detection interrupt enable
0	Interrupt signal output is disabled.
1	Interrupt signal output is enabled.

CCA INTEN	CCA completion interrupt enable
0	Interrupt signal output is disabled.
1	Interrupt signal output is enabled.

AGC INTEN	AGC completion interrupt enable
0	Interrupt signal output is disabled.
1	Interrupt signal output is enabled.

RCVBYTE INTEN	Number of received bytes interrupt enable
0	Interrupt signal output is disabled.
1	Interrupt signal output is enabled.

RCVFIN INTEN	Frame reception completion interrupt enable
0	Interrupt signal output is disabled.
1	Interrupt signal output is enabled.

RCVSTA INTEN	Reception start interrupt enable
0	Interrupt signal output is disabled.
1	Interrupt signal output is enabled.

Figure 4-98 Format of INTOUT0 Interrupt Enable Register 2 (BBINT0EN2) (2/2)

TRNSTART INTEN	Transmission start interrupt enable
0	Interrupt signal output is disabled.
1	Interrupt signal output is enabled.

TRNBYTE INTEN	Number of transmitted bytes interrupt enable
0	Interrupt signal output is disabled.
1	Interrupt signal output is enabled.

### 4.2.80 INTOUT0 interrupt enable register 3 (BBINT0EN3)

An interrupt enable bit enables the output of an interrupt signal on the GPIO port pin selected as the INTOUT0 output pin upon the generation of the corresponding interrupt request. To enable the output of an interrupt signal, set the corresponding interrupt enable bit. The value of this register following a reset is 00H.

Figure 4-99 Format of INTOUT0 Interrupt Enable Register 3 (BBINT0EN3)

Address: 00FFH After reset: 00H R/W<sup>Note</sup>

Symbol	7	6	5	4	3	2	1	0
BBINT0	CANCEL	0	0	TRNUNDRR	RCVTOUT	CCACLR	CCALIMIT	CS
EN3	INTEN			UNINTEN	INTEN	INTEN	INTEN	INTEN

CANCEL INTEN	Reception canceled interrupt enable
0	Interrupt signal output is disabled.
1	Interrupt signal output is enabled.

TRNUNDRR UNINTEN	Transmission underrun interrupt enable
0	Interrupt signal output is disabled.
1	Interrupt signal output is enabled.

RCVTOUT INTEN	Automatic reception timeout interrupt enable
0	Interrupt signal output is disabled.
1	Interrupt signal output is enabled.

CCACLR INTEN	CCA clearance interrupt enable
0	Interrupt signal output is disabled.
1	Interrupt signal output is enabled.

CCALIMIT INTEN	CCA limitation interrupt enable
0	Interrupt signal output is disabled.
1	Interrupt signal output is enabled.

CS INTEN	Carrier sense interrupt enable
0	Interrupt signal output is disabled.
1	Interrupt signal output is enabled.

**Caution** When writing to this register, set bits 6 and 5 to the value 0.

### 4.2.81 INTOUT0 interrupt enable register 4 (BBINT0EN4)

An interrupt enable bit enables the output of an interrupt signal on the GPIO port pin selected as the INTOUT0 output pin upon the generation of the corresponding interrupt request. To enable the output of an interrupt signal, set the corresponding interrupt enable bit. The value of this register following a reset is 00H.

**Figure 4-100 Format of INTOUT0 Interrupt Enable Register 4 (BBINT0EN4) (1/2)**

Address: 0100H After reset: 00H R/W

Symbol	7	6	5	4	3	2	1	0
BBINT0	TRNFIN	TRNFSYNC	TRNSTART	CSMA	TRNUNDRR	TRNBYTE	TRN1	TRN0
EN4	INTEN	INTEN	INTEN	INTEN	UNINTEN	INTEN	INTEN	INTEN

TRNFIN INTEN	Frame transmission completion interrupt enable
0	Interrupt signal output is disabled.
1	Interrupt signal output is enabled.

TRNFSYNC INTEN	Frame synchronization transmission completion interrupt enable
0	Interrupt signal output is disabled.
1	Interrupt signal output is enabled.

TRNSTART INTEN	Transmission start interrupt enable
0	Interrupt signal output is disabled.
1	Interrupt signal output is enabled.

CSMA INTEN	CSMA-CA completion or CCA completion interrupt enable
0	Interrupt signal output is disabled.
1	Interrupt signal output is enabled.

TRNUNDRR UNINTEN	Transmission underrun interrupt enable
0	Interrupt signal output is disabled.
1	Interrupt signal output is enabled.

TRNBYTE INTEN	Number of transmitted bytes interrupt enable
0	Interrupt signal output is disabled.
1	Interrupt signal output is enabled.

Figure 4-101 Format of INTOUT0 Interrupt Enable Register 4 (BBINT0EN4) (2/2)

TRN1 INTEN	Bank 1 transmission completion interrupt enable
0	Interrupt signal output is disabled.
1	Interrupt signal output is enabled.

TRN0 INTEN	Bank 0 transmission completion interrupt enable
0	Interrupt signal output is disabled.
1	Interrupt signal output is enabled.

### 4.2.82 INTOUT0 interrupt enable register 5 (BBINT0EN5)

An interrupt enable bit enables the output of an interrupt signal on the GPIO port pin selected as the INTOUT0 output pin upon the generation of the corresponding interrupt request. To enable the output of an interrupt signal, set the corresponding interrupt enable bit. The value of this register following a reset is 00H.

**Figure 4-102 Format of INTOUT0 Interrupt Enable Register 5 (BBINT0EN5) (1/2)**

Address: 0101H After reset: 00H R/W

Symbol	7	6	5	4	3	2	1	0
BBINT0	RCVTOUT	RCVLVL	RCVFIN	FL	RCVSTART	PREAMBL	CS	AGC
EN5	INTEN	INTEN	INTEN	INTEN	INTEN	INTEN	INTEN	INTEN

RCVTOUT INTEN	Automatic reception timeout interrupt enable
0	Interrupt signal output is disabled.
1	Interrupt signal output is enabled.

RCVLVL INTEN	Reception level interrupt enable
0	Interrupt signal output is disabled.
1	Interrupt signal output is enabled.

RCVFIN INTEN	Frame reception completion interrupt enable
0	Interrupt signal output is disabled.
1	Interrupt signal output is enabled.

FL INTEN	Frame length or address filtering interrupt enable
0	Interrupt signal output is disabled.
1	Interrupt signal output is enabled.

RCVSTART INTEN	Reception start interrupt enable
0	Interrupt signal output is disabled.
1	Interrupt signal output is enabled.

PREAMBL INTEN	Preamble detection interrupt enable
0	Interrupt signal output is disabled.
1	Interrupt signal output is enabled.

Figure 4-103 Format of INTOUT0 Interrupt Enable Register 5 (BBINT0EN5) (2/2)

CS INTEN	Carrier sense interrupt enable
0	Interrupt signal output is disabled.
1	Interrupt signal output is enabled.

AGC INTEN	AGC completion interrupt enable
0	Interrupt signal output is disabled.
1	Interrupt signal output is enabled.

### 4.2.83 INTOUT0 interrupt enable register 6 (BBINT0EN6)

An interrupt enable bit enables the output of an interrupt signal on the GPIO port pin selected as the INTOUT0 output pin upon the generation of the corresponding interrupt request. To enable the output of an interrupt signal, set the corresponding interrupt enable bit. The value of this register following a reset is 00H.

**Figure 4-104 Format of INTOUT0 Interrupt Enable Register 6 (BBINT0EN6) (1/2)**

Address: 0102H After reset: 00H R/W

Symbol	7	6	5	4	3	2	1	0
BBINT0	RCVLVL	RCVFIN	FL	RCVSTART	CCALIMIT	CCACLR	CCA	CSMA
EN6	INTEN	INTEN	INTEN	INTEN	INTEN	INTEN	INTEN	INTEN

RCVLVL INTEN	Reception level interrupt enable
0	Interrupt signal output is disabled.
1	Interrupt signal output is enabled.

RCVFIN INTEN	Frame reception completion interrupt enable
0	Interrupt signal output is disabled.
1	Interrupt signal output is enabled.

FL INTEN	Frame length or address filtering interrupt enable
0	Interrupt signal output is disabled.
1	Interrupt signal output is enabled.

RCVSTART INTEN	Reception start interrupt enable
0	Interrupt signal output is disabled.
1	Interrupt signal output is enabled.

CCALIMIT INTEN	CCA limitation interrupt enable
0	Interrupt signal output is disabled.
1	Interrupt signal output is enabled.

CCACLR INTEN	CCA clearance or reception canceled interrupt enable
0	Interrupt signal output is disabled.
1	Interrupt signal output is enabled.



Figure 4-105 Format of INTOUT0 Interrupt Enable Register 6 (BBINT0EN6) (2/2)

CCA INTEN	CCA completion interrupt enable
0	Interrupt signal output is disabled.
1	Interrupt signal output is enabled.

CSMA INTEN	CSMA-CA completion interrupt enable
0	Interrupt signal output is disabled.
1	Interrupt signal output is enabled.

#### 4.2.84 INTOUT0 interrupt enable register 7 (BBINT0EN7)

An interrupt enable bit enables the output of an interrupt signal on the GPIO port pin selected as the INTOUT0 output pin upon the generation of the corresponding interrupt request. To enable the output of an interrupt signal, set the corresponding interrupt enable bit. The value of this register following a reset is 00H.

**Figure 4-106 Format of INTOUT0 Interrupt Enable Register 7 (BBINT0EN7) (1/2)**

Address: 0103H After reset: 00H R/W

Symbol	7	6	5	4	3	2	1	0
BBINT0	RCVLVL	RCVFIN	FL	RCVSTART	ROVR	RCVBYTE	RCV1	RCV0
EN7	INTEN	INTEN	INTEN	INTEN	INTEN	INTEN	INTEN	INTEN

RCVLVL INTEN	Reception level interrupt enable
0	Interrupt signal output is disabled.
1	Interrupt signal output is enabled.

RCVFIN INTEN	Frame reception completion interrupt enable
0	Interrupt signal output is disabled.
1	Interrupt signal output is enabled.

FL INTEN	Frame length or address filtering interrupt enable
0	Interrupt signal output is disabled.
1	Interrupt signal output is enabled.

RCVSTART INTEN	Reception start interrupt enable
0	Interrupt signal output is disabled.
1	Interrupt signal output is enabled.

ROVR INTEN	Reception overrun interrupt enable
0	Interrupt signal output is disabled.
1	Interrupt signal output is enabled.

RCVBYTE INTEN	Number of received bytes interrupt enable
0	Interrupt signal output is disabled.
1	Interrupt signal output is enabled.

**Figure 4-107 Format of INTOUT0 Interrupt Enable Register 7 (BBINT0EN7) (2/2)**

RCV1 INTEN	Bank 1 reception completion interrupt enable
0	Interrupt signal output is disabled.
1	Interrupt signal output is enabled.

RCV0 INTEN	Bank 0 reception completion interrupt enable
0	Interrupt signal output is disabled.
1	Interrupt signal output is enabled.

### 4.2.85 INTOUT0 interrupt source enable register 0 (BBINT0REQEN0)

An interrupt source enable bit enables the generation of interrupt requests in response to the corresponding sources. Upon the generation of an interrupt request while the setting of the corresponding interrupt source enable bit is 1, the corresponding interrupt source flag is set to 1. The value of this register following a reset is 00H.

**Figure 4-108 Format of INTOUT0 Interrupt Source Enable Register 0 (BBINT0REQEN0) (1/2)**

Address: 0104H After reset: 00H R/W

Symbol	7	6	5	4	3	2	1	0
BBINT0	CSMA	FSYNC	TRN1	TRN0	CAL	TIM2	TIM1	TIM0
REQEN0	INTREQEN	INTREQEN	INTREQEN	INTREQEN	INTREQEN	INTREQEN	INTREQEN	INTREQEN

CSMA INTREQEN	CSMA-CA completion interrupt source enable
0	Interrupt request generation is disabled.
1	Interrupt request generation is enabled.

FSYNC INTREQEN	Frame synchronization transmission completion interrupt source enable
0	Interrupt request generation is disabled.
1	Interrupt request generation is enabled.

TRN1 INTREQEN	Bank 1 transmission completion interrupt source enable
0	Interrupt request generation is disabled.
1	Interrupt request generation is enabled.

TRN0 INTREQEN	Bank 0 transmission completion interrupt source enable
0	Interrupt request generation is disabled.
1	Interrupt request generation is enabled.

CAL INTREQEN	Calibration completion interrupt source enable
0	Interrupt request generation is disabled.
1	Interrupt request generation is enabled.

TIM2 INTREQEN	Timer comparison 2 interrupt source enable
0	Interrupt request generation is disabled.
1	Interrupt request generation is enabled.

Figure 4-109 Format of INTOUT0 Interrupt Source Enable Register 0 (BBINT0REQEN0) (2/2)

TIM1 INTREQEN	Timer comparison 1 interrupt source enable
0	Interrupt request generation is disabled.
1	Interrupt request generation is enabled.

TIM0 INTREQEN	Timer comparison 0 interrupt source enable
0	Interrupt request generation is disabled.
1	Interrupt request generation is enabled.

#### 4.2.86 INTOUT0 interrupt source enable register 1 (BBINT0REQEN1)

An interrupt source enable bit enables the generation of interrupt requests in response to the corresponding sources. Upon the generation of an interrupt request while the setting of the corresponding interrupt source enable bit is 1, the corresponding interrupt source flag is set to 1. The value of this register following a reset is 00H.

Figure 4-110 Format of INTOUT0 Interrupt Source Enable Register 1 (BBINT0REQEN1) (1/2)

Address: 0105H After reset: 00H R/W

Symbol	7	6	5	4	3	2	1	0
BBINT0 REQEN1	TRNFINT REQEN	RCVLVL INTREQEN	MODESW INTREQEN	ROVR INTREQEN	ADRS INTREQEN	FL INTREQEN	RCV1 INTREQEN	RCV0 INTREQEN

TRNFINT REQEN	Frame transmission completion interrupt source enable
0	Interrupt request generation is disabled.
1	Interrupt request generation is enabled.

RCVLVL INTREQEN	Reception level interrupt source enable
0	Interrupt request generation is disabled.
1	Interrupt request generation is enabled.

MODESW INTREQEN	Mode switch reception completion interrupt source enable
0	Interrupt request generation is disabled.
1	Interrupt request generation is enabled.

ROVR INTREQEN	Reception overrun interrupt source enable
0	Interrupt request generation is disabled.
1	Interrupt request generation is enabled.

ADRS INTREQEN	Address filtering interrupt source enable
0	Interrupt request generation is disabled.
1	Interrupt request generation is enabled.

FL INTREQEN	Frame length interrupt source enable
0	Interrupt request generation is disabled.
1	Interrupt request generation is enabled.

Figure 4-111 Format of INTOUT0 Interrupt Source Enable Register 1 (BBINT0REQEN1) (2/2)

RCV1 INTREQEN	Bank 1 reception completion interrupt source enable
0	Interrupt request generation is disabled.
1	Interrupt request generation is enabled.

RCV0 INTREQEN	Bank 0 reception completion interrupt source enable
0	Interrupt request generation is disabled.
1	Interrupt request generation is enabled.

#### 4.2.87 INTOUT0 interrupt source enable register 2 (BBINT0REQEN2)

An interrupt source enable bit enables the generation of interrupt requests in response to the corresponding sources. Upon the generation of an interrupt request while the setting of the corresponding interrupt source enable bit is 1, the corresponding interrupt source flag is set to 1. The value of this register following a reset is 00H.

**Figure 4-112 Format of INTOUT0 Interrupt Source Enable Register 2 (BBINT0REQEN2) (1/2)**

Address: 0106H After reset: 00H R/W

Symbol	7	6	5	4	3	2	1	0
BBINT0	PREAMBL	CCA	AGC	RCVBYTE	RCVFIN	RCVSTA	TRNSTART	TRNBYTE
REQEN2	INTREQEN	INTREQEN	INTREQEN	INTREQEN	INTREQEN	INTREQEN	INTREQEN	INTREQEN

PREAMBL INTREQEN	Preamble detection interrupt source enable
0	Interrupt request generation is disabled.
1	Interrupt request generation is enabled.

CCA INTREQEN	CCA completion interrupt source enable
0	Interrupt request generation is disabled.
1	Interrupt request generation is enabled.

AGC INTREQEN	AGC completion interrupt source enable
0	Interrupt request generation is disabled.
1	Interrupt request generation is enabled.

RCVBYTE INTREQEN	Number of received bytes interrupt source enable
0	Interrupt request generation is disabled.
1	Interrupt request generation is enabled.

RCVFIN INTREQEN	Frame reception completion interrupt source enable
0	Interrupt request generation is disabled.
1	Interrupt request generation is enabled.

RCVSTA INTREQEN	Reception start interrupt source enable
0	Interrupt request generation is disabled.
1	Interrupt request generation is enabled.



Figure 4-113 Format of INTOUT0 Interrupt Source Enable Register 2 (BBINT0REQEN2) (2/2)

TRNSTART INTREQEN	Transmission start interrupt source enable
0	Interrupt request generation is disabled.
1	Interrupt request generation is enabled.

TRNBYTE INTREQEN	Number of transmitted bytes interrupt source enable
0	Interrupt request generation is disabled.
1	Interrupt request generation is enabled.

### 4.2.88 INTOUT0 interrupt source enable register 3 (BBINT0REQEN3)

An interrupt source enable bit enables the generation of interrupt requests in response to the corresponding sources. Upon the generation of an interrupt request while the setting of the corresponding interrupt source enable bit is 1, the corresponding interrupt source flag is set to 1. The value of this register following a reset is 00H.

Figure 4-114 Format of INTOUT0 Interrupt Source Enable Register 3 (BBINT0REQEN3) (1/2)

Address: 0107H After reset: 00H R/W

Symbol	7	6	5	4	3	2	1	0
BBINT0 REQEN3	CANCEL INTREQEN	0	0	TRNUNDRR UN INTREQEN	RCVTOUT INTREQEN	CCA CLR INTREQEN	CCALIMIT INTREQEN	CS INTREQEN

CANCEL INTREQEN	Reception canceled interrupt source enable
0	Interrupt request generation is disabled.
1	Interrupt request generation is enabled.

TRNUNDRR UN INTREQEN	Transmission underrun interrupt source enable
0	Interrupt request generation is disabled.
1	Interrupt request generation is enabled.

RCVTOUT INTREQEN	Automatic reception timeout interrupt source enable
0	Interrupt request generation is disabled.
1	Interrupt request generation is enabled.

CCA CLR INTREQEN	CCA clearance interrupt source enable
0	Interrupt request generation is disabled.
1	Interrupt request generation is enabled.

CCALIMIT INTREQEN	CCA limitation interrupt source enable
0	Interrupt request generation is disabled.
1	Interrupt request generation is enabled.

Figure 4-115 Format of INTOUT0 Interrupt Source Enable Register 3 (BBINT0REQEN3) (2/2)

CS INTREQEN	Carrier sense interrupt source enable
0	Interrupt request generation is disabled.
1	Interrupt request generation is enabled.

**Caution** When writing to this register, set bits 6 and 5 to the value 0.

#### 4.2.89 INTOUT0 interrupt source enable register 4 (BBINT0REQEN4)

An interrupt source enable bit enables the generation of interrupt requests in response to the corresponding sources. Upon the generation of an interrupt request while the setting of the corresponding interrupt source enable bit is 1, the corresponding interrupt source flag is set to 1. The value of this register following a reset is 00H.

Figure 4-116 Format of INTOUT0 Interrupt Source Enable Register 4 (BBINT0REQEN4) (1/2)

Address: 0108H After reset: 00H R/W

Symbol	7	6	5	4	3	2	1	0
BBINT0 REQEN4	TRNFIN INTREQEN	TRNFSYNC INTREQEN	TRNSTART INTREQEN	CSMA INTREQEN	TRNUNDRR UN INTREQEN	TRNBYTE INTREQEN	TRN1 INTREQEN	TRN0 INTREQEN

TRNFIN INTREQEN	Frame transmission completion interrupt source enable
0	Interrupt request generation is disabled.
1	Interrupt request generation is enabled.

TRNFSYNC INTREQEN	Frame synchronization transmission completion interrupt source enable
0	Interrupt request generation is disabled.
1	Interrupt request generation is enabled.

TRNSTART INTREQEN	Transmission start interrupt source enable
0	Interrupt request generation is disabled.
1	Interrupt request generation is enabled.

CSMA INTREQEN	CSMA-CA completion or CCA completion interrupt source enable
0	Interrupt request generation is disabled.
1	Interrupt request generation is enabled.

TRNUNDRR UN INTREQEN	Transmission underrun interrupt source enable
0	Interrupt request generation is disabled.
1	Interrupt request generation is enabled.

Figure 4-117 Format of INTOUT0 Interrupt Source Enable Register 4 (BBINT0REQEN4) (2/2)

TRNBYTE INTREQEN	Number of transmitted bytes interrupt source enable
0	Interrupt request generation is disabled.
1	Interrupt request generation is enabled.

TRN1 INTREQEN	Bank 1 transmission completion interrupt source enable
0	Interrupt request generation is disabled.
1	Interrupt request generation is enabled.

TRN0 INTREQEN	Bank 0 transmission completion interrupt source enable
0	Interrupt request generation is disabled.
1	Interrupt request generation is enabled.

#### 4.2.90 INTOUT0 interrupt source enable register 5 (BBINT0REQEN5)

An interrupt source enable bit enables the generation of interrupt requests in response to the corresponding sources. Upon the generation of an interrupt request while the setting of the corresponding interrupt source enable bit is 1, the corresponding interrupt source flag is set to 1. The value of this register following a reset is 00H.

Figure 4-118 Format of INTOUT0 Interrupt Source Enable Register 5 (BBINT0REQEN5) (1/2)

Address: 0109H After reset: 00H R/W

Symbol	7	6	5	4	3	2	1	0
BBINT0	RCVTOUT	RCVLVL	RCVFIN	FL	RCVSTART	PREAMBL	CS	AGC
REQEN5	INTREQEN	INTREQEN	INTREQEN	INTREQEN	INTREQEN	INTREQEN	INTREQEN	INTREQEN

RCVTOUT INTREQEN	Automatic reception timeout interrupt source enable
0	Interrupt request generation is disabled.
1	Interrupt request generation is enabled.

RCVLVL INTREQEN	Reception level interrupt source enable
0	Interrupt request generation is disabled.
1	Interrupt request generation is enabled.

RCVFIN INTREQEN	Frame reception completion interrupt source enable
0	Interrupt request generation is disabled.
1	Interrupt request generation is enabled.

FL INTREQEN	Frame length or address filtering interrupt source enable
0	Interrupt request generation is disabled.
1	Interrupt request generation is enabled.

RCVSTART INTREQEN	Reception start interrupt source enable
0	Interrupt request generation is disabled.
1	Interrupt request generation is enabled.

Figure 4-119 Format of INTOUT0 Interrupt Source Enable Register 5 (BBINT0REQEN5) (2/2)

PREAMBL INTREQEN	Preamble detection interrupt source enable
0	Interrupt request generation is disabled.
1	Interrupt request generation is enabled.

CS INTREQEN	Carrier sense interrupt source enable
0	Interrupt request generation is disabled.
1	Interrupt request generation is enabled.

AGC INTREQEN	AGC completion interrupt source enable
0	Interrupt request generation is disabled.
1	Interrupt request generation is enabled.

#### 4.2.91 INTOUT0 interrupt source enable register 6 (BBINT0REQEN6)

An interrupt source enable bit enables the generation of interrupt requests in response to the corresponding sources. Upon the generation of an interrupt request while the setting of the corresponding interrupt source enable bit is 1, the corresponding interrupt source flag is set to 1. The value of this register following a reset is 00H.

Figure 4-120 Format of INTOUT0 Interrupt Source Enable Register 6 (BBINT0REQEN6) (1/2)

Address: 010AH After reset: 00H R/W

Symbol	7	6	5	4	3	2	1	0
BBINT0 REQEN6	RCVLVL INTREQEN	RCVFIN INTREQEN	FL INTREQEN	RCVSTART INTREQEN	CCALIMIT INTREQEN	CCACLR INTREQEN	CCA INTREQEN	CSMA INTREQEN

RCVLVL INTREQEN	Reception level interrupt source enable
0	Interrupt request generation is disabled.
1	Interrupt request generation is enabled.

RCVFIN INTREQEN	Frame reception completion interrupt source enable
0	Interrupt request generation is disabled.
1	Interrupt request generation is enabled.

FL INTREQEN	Frame length or address filtering interrupt source enable
0	Interrupt request generation is disabled.
1	Interrupt request generation is enabled.

RCVSTART INTREQEN	Reception start interrupt source enable
0	Interrupt request generation is disabled.
1	Interrupt request generation is enabled.

CCALIMIT INTREQEN	CCA limitation interrupt source enable
0	Interrupt request generation is disabled.
1	Interrupt request generation is enabled.



Figure 4-121 Format of INTOUT0 Interrupt Source Enable Register 6 (BBINT0REQEN6) (2/2)

CCACLR INTREQEN	CCA clearance or reception canceled interrupt source enable
0	Interrupt request generation is disabled.
1	Interrupt request generation is enabled.

CCA INTREQEN	CCA completion interrupt source enable
0	Interrupt request generation is disabled.
1	Interrupt request generation is enabled.

CSMA INTREQEN	CSMA-CA completion interrupt source enable
0	Interrupt request generation is disabled.
1	Interrupt request generation is enabled.

#### 4.2.92 INTOUT0 interrupt source enable register 7 (BBINT0REQEN7)

An interrupt source enable bit enables the generation of interrupt requests in response to the corresponding sources. Upon the generation of an interrupt request while the setting of the corresponding interrupt source enable bit is 1, the corresponding interrupt source flag is set to 1. The value of this register following a reset is 00H.

Figure 4-122 Format of INTOUT0 Interrupt Source Enable Register 7 (BBINT0REQEN7) (1/2)

Address: 010BH After reset: 00H R/W

Symbol	7	6	5	4	3	2	1	0
BBINT0	RCVLVL	RCVFIN	FL	RCVSTART	ROVR	RCVBYTE	RCV1	RCV0
REQEN7	INTREQEN	INTREQEN	INTREQEN	INTREQEN	INTREQEN	INTREQEN	INTREQEN	INTREQEN

RCVLVL INTREQEN	Reception level interrupt source enable
0	Interrupt request generation is disabled.
1	Interrupt request generation is enabled.

RCVFIN INTREQEN	Frame reception completion interrupt source enable
0	Interrupt request generation is disabled.
1	Interrupt request generation is enabled.

FL INTREQEN	Frame length or address filtering interrupt source enable
0	Interrupt request generation is disabled.
1	Interrupt request generation is enabled.

RCVSTART INTREQEN	Reception start interrupt source enable
0	Interrupt request generation is disabled.
1	Interrupt request generation is enabled.

ROVR INTREQEN	Reception overrun interrupt source enable
0	Interrupt request generation is disabled.
1	Interrupt request generation is enabled.

Figure 4-123 Format of INTOUT0 Interrupt Source Enable Register 7 (BBINT0REQEN7) (2/2)

RCVBYTE INTREQEN	Number of received bytes interrupt source enable
0	Interrupt request generation is disabled.
1	Interrupt request generation is enabled.

RCV1 INTREQEN	Bank 1 reception completion interrupt source enable
0	Interrupt request generation is disabled.
1	Interrupt request generation is enabled.

RCV0 INTREQEN	Bank 0 reception completion interrupt source enable
0	Interrupt request generation is disabled.
1	Interrupt request generation is enabled.

### 4.2.93 Number-of-transmitted-byte interrupt comparison register (BBTRNINTCOMP)

This register is used to generate interrupts depending on the number of transmitted bytes. An interrupt request is generated when the specified number of bytes are transferred from the transmission RAM to the transmitter. The value specified in this register can be modified even while transmission is in progress. In this case, the new value takes effect after an interrupt is generated based on the old value. The value of this register following a reset is 0010H.

**Figure 4-124 Format of Number-of-Transmitted-Byte Interrupt Comparison Register (BBTRNINTCOMP)**

Address: 0117H, 0116H After reset: 0010H R/W

Symbol	15	14	13	12	11	10	9	8
BBTRNINT COMP (0117H)	0	0	0	0	TRNINT COMP11	TRNINT COMP10	TRNINT COMP9	TRNINT COMP8
	7	6	5	4	3	2	1	0
(0116H)	TRNINT COMP7	TRNINT COMP6	TRNINT COMP5	TRNINT COMP4	TRNINT COMP3	TRNINT COMP2	TRNINT COMP1	TRNINT COMP0
	TRNINTCOMP11 to TRNINTCOMP0		Number-of-transmit-byte interrupt compare					
	—		These bits set the number of bytes that generates a number-of-transmit-byte interrupt.					

**Caution** When writing to this register, set bits 15 to 12 to the value 0.

#### 4.2.94 CCA mode register (BBCCAMODE)

The CCA mode can be specified by the CCA mode bits.

1. CCA mode bits = 00B: CCA proceeds by comparing the detected power value with the CCAVTH value.
2. CCA mode bits = 01B: CCA proceeds by checking whether the sensed carrier signal is detected.
3. CCA mode bits = 10B: CCA proceeds by the logical OR of the results of (1) and (2).
4. CCA mode bits = 11B: CCA proceeds by the logical AND of the results of (1) and (2).

The CCA continuation enable bit is used to continue CCA until the frequency channel is found to be cleared, instead of terminating the operation after CCA. When CCA is proceeds in this continuation enabled mode, this device updates the values in the CCA judge result bit, and ED1 result register and ED2 result register on detection of power value and continues CCA until the frequency channel is found to be cleared. To stop CCA, use the RF communication stop bit. CCA also stops after the frequency channel is found to be cleared (including the case when the frequency channel is cleared at the start of CCA). Be sure to use the continuation mode only while the CCA mode bits are set to 00B. Note that, when the setting of the CCA mode bit is 1, do not set the mid-CCA reception enable bit or the automatic CSMA-CA start bit to 1. This mode cannot be used together with the mid-CCA reception enable mode or the automatic CSMA-CA mode. The CCA continuation mode bit switches the operating mode when CCA continuation is enabled. While this bit is set to 1, CCA stops when the number of CCA repetitions reaches the value specified in the CCA limit setting register. While this bit is set to 0, CCA stops after the frequency channel is found to be cleared. The mid-CCA reception enable bit is used to stop CCA and proceed to frame reception when signal reception is detected during CCA. This mode cannot be used together with the automatic CSMA-CA mode. In addition, the automatic receive switch mode or high-speed receive switch function cannot be used. Once the reception start operation begins, a CCA completion interrupt is generated. As the receive operation is triggered by the reception start signal, the hardware may cancel the reception — for example, if an illegal frame length is detected. In this case, a reception cancellation interrupt is generated. If reception is canceled in this mode, this device does not return to the receive wait state. The value of this register following a reset is 00H.

**Figure 4-125 Format of CCA Mode Register (BBCCAMODE) (1/2)**

Address: 0118H After reset: 00H R/W

Symbol	7	6	5	4	3	2	1	0
BBCCA MODE	0	0	0	CCA RCVEN	CCACONT INUESEL	CCACONT INUEEN	CCA MODE1	CCA MODE0

CCA RCVEN	Mid-CCA reception enable
0	Normal operation.
1	Reception is enabled during CCA.

CCACON TINUESEL	CCA continuation mode
0	CCA continues until the frequency channel is found to be cleared.
1	CCA continues until the specified count is reached.

Figure 4-126 Format of CCA Mode Register (BBCCAMODE) (2/2)

CCACON TINUEEN	CCA continuation enable
0	Normal operation (CCA stops after execution).
1	CCA is continued.

CCA MODE1	CCA MODE0	CCA mode
0	0	Power value is compared with CCAVTH.
0	1	Whether the sensed carrier signal is detected is checked.
1	0	Logical OR of the results of the above checks.
1	1	Logical AND of the results of the above checks.

**Caution** When writing to this register, set bits 7 to 5 to the value 0.

### 4.2.95 Receive mode register (BBRCVMODE)

The MS frame discard bit is used to discard the mode switch frame received. When a mode switch frame is received while this bit is set to 1, this device automatically enters the IDLE state and then returns to the receive wait state again. Note that a mode switch reception completion interrupt does not occur even if a mode switch frame is received. In this case, the mode switch frame reception register is not updated. The value of this register following a reset is 00H.

**Figure 4-127 Format of Receive Mode Register (BBRCVMODE)**

Address: 0119H After reset: 00H R/W

Symbol	7	6	5	4	3	2	1	0
BBRCV MODE	0	0	0	0	0	0	0	MSCANCEL EN

MSCANCEL EN	MS frame discard
0	Mode switch frame is not discarded.
1	Mode switch frame is discarded.

**Caution** When writing to this register, set bits 7 to 1 to the value 0.

### 4.2.96 Frame cancellation minimum length register (BBFLCNCLMIN)

This register is used to set the length of the received frame to be discarded. When the length of the received frame is equal to or smaller than the value specified in this register, this device discards the frame. Set a value from 0002H to 07FFH. Note that the received frame is always discarded regardless of this setting if its length is 4 bytes or smaller for a frame with the 32-bit CRC or 2 bytes or smaller for a frame with the 16-bit CRC. The value of this register following a reset is 0002H.

**Figure 4-128 Format of Frame Cancellation Minimum Length Register (BBFLCNCLMIN)**

Address: 011BH, 011AH After reset: 0002H R/W

Symbol	15	14	13	12	11	10	9	8
BBFLCNCL MIN (011BH)	0	0	0	0	0	FLCNCL MIN10	FLCNCL MIN9	FLCNCL MIN8
	7	6	5	4	3	2	1	0
(011AH)	FLCNCL MIN7	FLCNCL MIN6	FLCNC LMIN5	FLCNCL MIN4	FLCNCL MIN3	FLCNCL MIN2	FLCNCL MIN1	FLCNCL MIN0
	FLCNCLMIN10 to FLCNCLMIN0		Minimum frame length for comparison					
	—		These bits set the length of the received frame to be discarded.					

**Caution** When writing to this register, set bits 15 to 11 to the value 0.



### 4.2.97 Frame cancellation maximum length register (BBFLCNCLMAX)

This register is used to set the length of the received frame to be discarded. When the length of the received frame is equal to or greater than the value specified in this register, this device discards the frame. Set a value from 0008H to 0800H. To stop discarding a frame, specify 0800H. The value of this register following a reset is 0800H.

**Figure 4-129 Format of Frame Cancellation Maximum Length Register (BBFLCNCLMAX)**

Address: 011DH, 011CH After reset: 0800H R/W

Symbol	15	14	13	12	11	10	9	8
BBFLCNCL MAX (011DH)	0	0	0	0	FLCNCL MAX11	FLCNCL MAX10	FLCNCL MAX9	FLCNCL MAX8
(011CH)	7	6	5	4	3	2	1	0
	FLCNCL MAX7	FLCNCL MAX6	FLCNCL MAX5	FLCNCL MAX4	FLCNCL MAX3	FLCNCL MAX2	FLCNCL MAX1	FLCNCL MAX0
FLCNCLMAX11 to FLCNCLMAX0		Frame cancellation maximum length for comparison						
—		These bits set the length of the received frame to be discarded.						

**Caution** When writing to this register, set bits 15 to 11 to the value 0.

#### 4.2.98 Number-of-byte interrupt mode register (BBYTEINTMODE)

The number-of-transmit-byte interrupt mode bit and number-of-receive-byte interrupt mode bit are used to specify the conditions for generating number-of-transmit-byte interrupts and number-of-receive-byte interrupts, respectively. The ADF link bit for the number-of-receive-byte interrupt is used to link the address match detected by the address filter (when enabled) to the condition for the number-of-receive-byte interrupt when the number-of-receive-byte interrupt mode bit is set to 1. When this link is enabled, a number-of-receive-byte interrupt is generated only after the reception of a byte following the detection of an address match. The value of this register following a reset is 07H.

**Figure 4-130 Format of Number-of-Byte Interrupt Mode Register (BBYTEINTMODE)**

Address: 011EH After reset: 07H R/W

Symbol	7	6	5	4	3	2	1	0
BBBYTE INTMODE	0	0	0	0	0	RXCOUNT INTADF	RXCOUNT INTSEL	TXCOUNT INTSEL

RXCOUNT INTADF	ADF link with the number-of-receive-byte interrupt
0	Interrupt generation is independent of the address match detected by the address filter.
1	Interrupt generation is linked with the address match detected by the address filter.

RXCOUNT INTSEL	Number-of-receive-byte interrupt mode
0	An interrupt is generated only one time after the number of bytes is specified.
1	An interrupt is generated every time the specified number of bytes is reached.

TXCOUNT INTSEL	Number-of-transmit-byte interrupt mode
0	An interrupt is generated only one time after the number of bytes is specified.
1	An interrupt is generated every time the specified number of bytes is reached.

**Caution** When writing to this register, set bits 7 to 3 to the value 0.

#### 4.2.99 RSSI result register (BBRSSIRSLT)

This register holds the RSSI result value. The 10-bit power value at the start of reception is stored in the RSSIRSLT bits. The RSSI result corresponding to the save bank specified by the receive data save bank select bit is read from this register. The read value is a 2's complement indicating a value from -256.0 dBm to +255.5 dBm in steps of 0.5 dBm. The unit of indication is dBm. For example, 33DH indicates -97.5 dBm. The value of this register following a reset is 0200H.

Figure 4-131 Format of RSSI Result Register (BBRSSIRSLT)

Address: 0121H, 0120H After reset: 0200H R

Symbol	15	14	13	12	11	10	9	8
BBRSSIRSLT (0121H)	0	0	0	0	0	0	RSSIRSLT 9	RSSIRSLT 8
	7	6	5	4	3	2	1	0
(0120H)	RSSIRSLT 7	RSSIRSLT 6	RSSIRSLT 5	RSSIRSLT 4	RSSIRSLT 3	RSSIRSLT 2	RSSIRSLT 1	RSSIRSLT 0

  

RSSIRSLT9 to RSSIRSLT0	RSSI result value
—	10-bit RSSI result value

### 4.2.100 RCPI result register (BBRCPIRSLT)

This register holds the RCPI result value. The 10-bit average of the received power values is stored in the RCPIRSLT bits. The RCPI result corresponding to the save bank specified by the receive data save bank select bit is read from this register. The read value is a 2's complement indicating a value from -256.0 dBm to +255.5 dBm in steps of 0.5 dBm. The unit of indication is dBm. For example, 33DH indicates -97.5 dBm. The value of this register following a reset is 0200H.

Figure 4-132 Format of RCPI Result Register (BBRCPIRSLT)

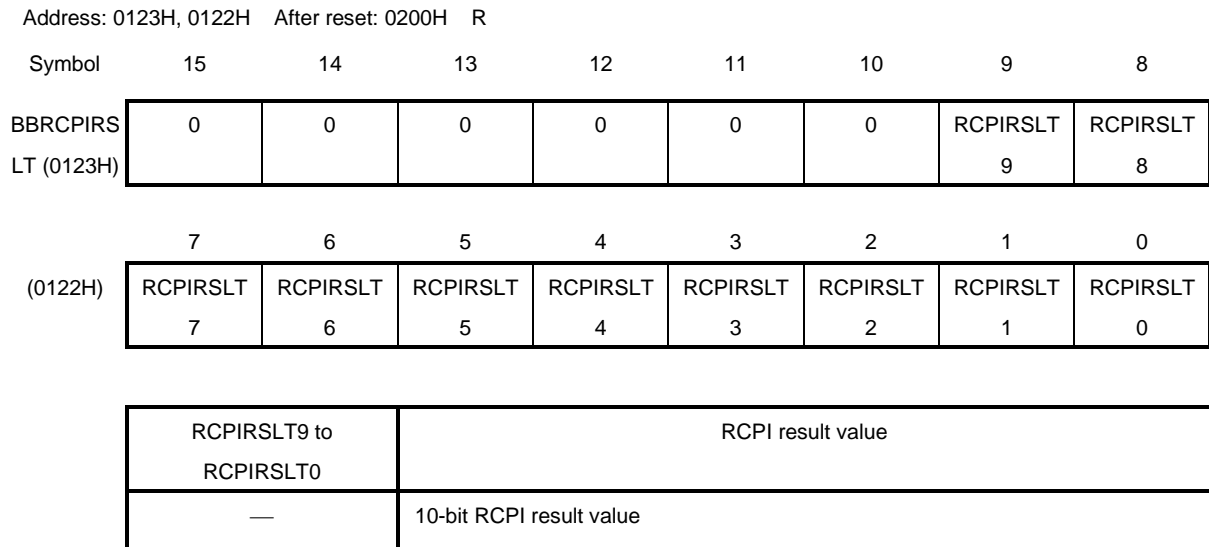

### 4.2.101 RSSI result 2 register (BBRSSIRSLT2)

This register holds the RSSI result value. The 8-bit power value at the start of reception is stored in the RSSIRSLT2 bits. The RSSI result corresponding to the save bank specified by the receive data save bank select bit is read from this register. The read value is a 2's complement indicating a value from -128 dBm to +127 dBm in steps of 1 dBm. The unit of indication is dBm. For example, 9EH indicates -98 dBm. The value of this register following a reset is 80H.

Figure 4-133 Format of RSSI Result 2 Register (BBRSSIRSLT2)

Address: 0124H After reset: 80H R

Symbol	7	6	5	4	3	2	1	0
BBRSSIRSLT2	RSSIRSLT2	RSSIRSLT2	RSSIRSLT2	RSSIRSLT2	RSSIRSLT2	RSSIRSLT2	RSSIRSLT2	RSSIRSLT2
LT2	7	6	5	4	3	2	1	0

RSSIRSLT27 to RSSIRSLT20	RSSI result value 2
—	8-bit RSSI result value

### 4.2.102 RCPI result 2 register (BBRCPIRSLT2)

This register holds the RCPI result value. The 8-bit average of the received power values is stored in the RCPIRSLT2 bits. The RCPI result corresponding to the save bank specified by the receive data save bank select bit is read from this register. The read value is a 2's complement indicating a value from -128 dBm to +127 dBm in steps of 1 dBm. The unit of indication is dBm. For example, 9EH indicates -98 dBm. The value of this register following a reset is 80H.

**Figure 4-134 Format of RCPI Result 2 Register (BBRCPIRSLT2)**

Address: 0125H After reset: 80H R

Symbol	7	6	5	4	3	2	1	0
BBRCPIRS LT2	RCPIRSLT2 7	RCPIRSLT2 6	RCPIRSLT2 5	RCPIRSLT2 4	RCPIRSLT2 3	RCPIRSLT2 2	RCPIRSLT2 1	RCPIRSLT2 0
RCPIRSLT27 to RCPIRSLT20		RCPI result value 2						
—		8-bit RCPI result value						

### 4.2.103 ED1 result register (BBED1RSLT)

This register holds the ED result value in FSK modulation. The value is retained until the next CCA operation begins. A 10-bit power value is stored in the ED1RSLT bits. The read value is a 2's complement indicating a value from -256.0 dBm to +255.5 dBm in steps of 0.5 dBm. The unit of indication is dBm. For example, 33DH indicates -97.5 dBm. The value of this register following a reset is 0200H.

**Figure 4-135 Format of ED1 Result Register (BBED1RSLT)**

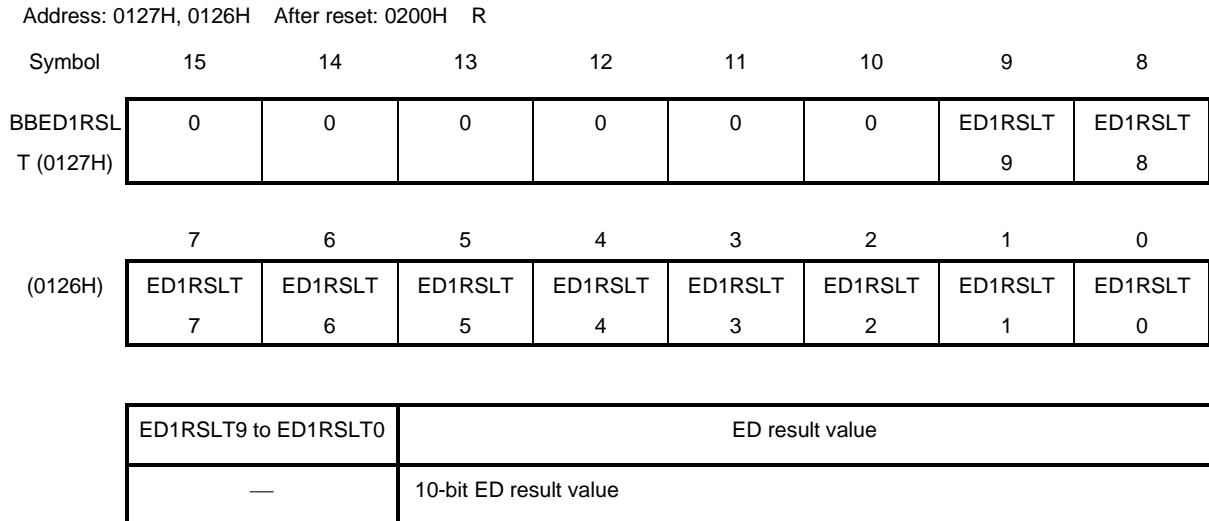

#### 4.2.104 ED2 result register (BBED2RSLT)

This register holds the ED result value in OFDM modulation. The value is retained until the next CCA operation begins. A 10-bit power value is stored in the ED2RSLT bits. The read value is a 2's complement indicating a value from -256.0 dBm to +255.5 dBm in steps of 0.5 dBm. The unit of indication is dBm. For example, 33DH indicates -97.5 dBm. The value of this register following a reset is 0200H.

**Figure 4-136 Format of ED2 Result Register (BBED2RSLT)**

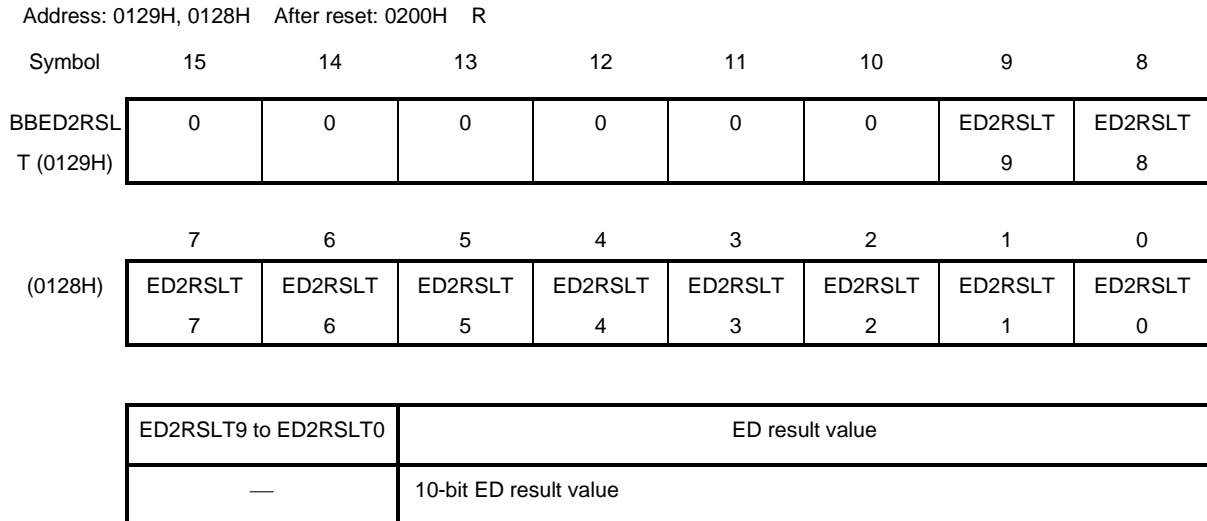



### 4.2.105 ED1 result 2 register (BBED1RSLT2)

This register holds the ED result value in FSK modulation. The value is retained until the next CCA operation begins. An 8-bit power value is stored in the ED1RSLT2 bits. The read value is a 2's complement indicating a value from -128 dBm to +127 dBm in steps of 1 dBm. The unit of indication is dBm. For example, 9EH indicates -98 dBm. The value of this register following a reset is 80H.

Figure 4-137 Format of ED1 Result 2 Register (BBED1RSLT2)

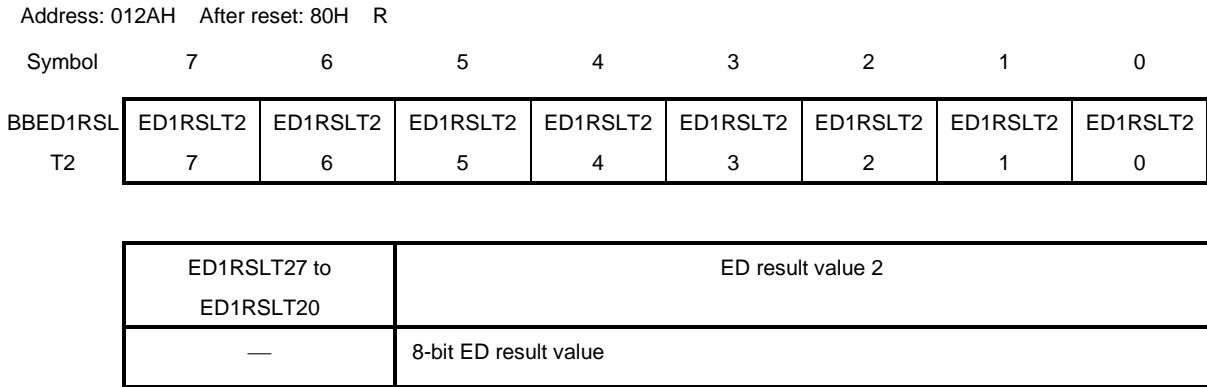

### 4.2.106 ED2 result 2 register (BBED2RSLT2)

This register holds the ED result value in OFDM modulation. The value is retained until the next CCA operation begins. An 8-bit power value is stored in the ED2RSLT2 bits. The read value is a 2's complement indicating a value from -128 dBm to +127 dBm in steps of 1 dBm. The unit of indication is dBm. For example, 9EH indicates -98 dBm. The value of this register following a reset is 80H.

**Figure 4-138 Format of ED2 Result 2 Register (BBED2RSLT2)**

Address: 012BH After reset: 80H R

Symbol	7	6	5	4	3	2	1	0
BBED1RSLT2	ED2RSLT2	ED2RSLT2	ED2RSLT2	ED2RSLT2	ED2RSLT2	ED2RSLT2	ED2RSLT2	ED2RSLT2
T2	7	6	5	4	3	2	1	0

ED2RSLT27 to ED2RSLT20	ED result value 2
—	8-bit ED result value

### 4.2.107 CCA clearance count register (BBCCACLRCOUNT)

This register is used to set the maximum number of clear operations while the CCA continuation enable bit is set to 1. When the number of clear operations reaches the value specified in this register, a CCA clearance interrupt is generated and the CCA operation is stopped. Set a value from 01H to 03H. The value of this register following a reset is 01H.

Figure 4-139 Format of CCA Clearance Count Register (BBCCACLRCOUNT)

Address: 012DH After reset: 01H R/W

Symbol	7	6	5	4	3	2	1	0
BBCCACLR RCOUNT	0	0	0	0	0	0	CCACLR COUNT1	CCACLR COUNT0

CCACLR COUNT1, 0	Number of CCA clear operations
—	Maximum number of CCA clear operations

**Caution** When writing to this register, set bits 7 to 2 to the value 0.

### 4.2.108 CCA limit setting register (BCCALIMIT)

This register is used to set the limit on the number of CCA repetitions when the CCA continuation mode bit is set to 1. This device stops the continuation of CCA operation when the number of CCA repetitions reaches the value specified in this register. In this case, a CCA limit interrupt is generated. The value of this register following a reset is 0100H.

Figure 4-140 Format of CCA Limit Setting Register (BCCALIMIT)

Address: 012FH, 012EH After reset: 0100H R/W

Symbol	15	14	13	12	11	10	9	8
BCCALIMIT (012FH)	CCALIMIT 15	CCALIMIT 14	CCALIMIT 13	CCALIMIT 12	CCALIMIT 11	CCALIMIT 10	CCALIMIT 9	CCALIMIT 8
(012EH)	7	6	5	4	3	2	1	0
	CCALIMIT 7	CCALIMIT 6	CCALIMIT 5	CCALIMIT 4	CCALIMIT 3	CCALIMIT 2	CCALIMIT 1	CCALIMIT 0

CCALIMIT15 to CCALIMIT0	CCA repetition limit
—	Maximum number of CCA repetitions until the frequency channel is found to be cleared

#### 4.2.109 Comparison 0 setting excess time registers (BBPASSTIME0 and BBPASSTIME1)

These registers are used to set the maximum elapsed time after the time specified in timer comparison register 0 is reached while both the COMP0 transmit trigger enable bit and the COMP0-excess transmission enable bit are set enabled. This device transmits data when the difference between the timer count value and the value specified in the timer comparison registers 0 and 1 (BBTCOMP0REG0 and BBTCOMP0REG1) is equal to or smaller than the time specified in these registers. The value of these registers following a reset is 80000000H.

Figure 4-141 Format of Comparison 0 Setting Excess Time Registers (BBPASSTIME0 and BBPASSTIME1)

Address: 0131H, 0130H After reset: 0000H R/W

Symbol	15	14	13	12	11	10	9	8
BBPASS TIME0 (0131H)	PASSTIME0	PASSTIME0	PASSTIME0	PASSTIME0	PASSTIME0	PASSTIME0	PASSTIME0	PASSTIME0
	15	14	13	12	11	10	9	8
(0130H)	7	6	5	4	3	2	1	0
	PASSTIME0	PASSTIME0	PASSTIME0	PASSTIME0	PASSTIME0	PASSTIME0	PASSTIME0	PASSTIME0
	7	6	5	4	3	2	1	0
PASSTIME015 to PASSTIME00		Comparison 0 setting excess time register 0						

Address: 0133H, 0132H After reset: 8000H R/W

Symbol	15	14	13	12	11	10	9	8
BBPASS TIME1 (0133H)	PASSTIME1	PASSTIME1	PASSTIME1	PASSTIME1	PASSTIME1	PASSTIME1	PASSTIME1	PASSTIME1
	15	14	13	12	11	10	9	8
(0132H)	7	6	5	4	3	2	1	0
	PASSTIME1	PASSTIME1	PASSTIME1	PASSTIME1	PASSTIME1	PASSTIME1	PASSTIME1	PASSTIME1
	7	6	5	4	3	2	1	0
PASSTIME115 to PASSTIME10		Comparison 0 setting excess time register 1						

### 4.2.110 Frame synchronization power value read register (BBFSYNCPOWRD)

This register holds the power value of the frame synchronization section of the frame being received. The 10-bit power value of the frame synchronization section is stored in the FSYNCPOWRD bits. The receive level filter function uses this power value. The read value is a 2's complement indicating a value from -256.0 dBm to +255.5 dBm in steps of 0.5 dBm. The unit of indication is dBm. For example, 33DH indicates -97.5 dBm. The value of this register following a reset is 0200H.

**Figure 4-142 Format of Frame Synchronization Power Value Read Register (BBFSYNCPOWRD)**

Address: 0135H, 0134H After reset: 0200H R

Symbol	15	14	13	12	11	10	9	8
BBFSYNC POWRD (0135H)	0	0	0	0	0	0	FSYNCPOW RD9	FSYNCPOW RD8
	7	6	5	4	3	2	1	0
(0134H)	FSYNCPOW RD7	FSYNCPOW RD6	FSYNCPOW RD5	FSYNCPOW RD4	FSYNCPOW RD3	FSYNCPOW RD2	FSYNCPOW RD1	FSYNCPOW RD0
FSYNCPOWRD9 to FSYNCPOWRD0		Frame synchronization power value read						
—		10-bit power value of the frame synchronization section in the frame being received						

### 4.2.111 Frame synchronization power value 2 read register (BBFSYNCPOWRD2)

This register holds the power value of the frame synchronization section of the frame being received. The 8-bit power value at the start of reception is stored in the FSYNCPOWRD2 bits. The read value is a 2's complement indicating a value from -128 dBm to +127 dBm in steps of 1 dBm. The unit of indication is dBm. For example, 9EH indicates -98 dBm. The value of this register following a reset is 80H.

**Figure 4-143 Format of Frame Synchronization Power Value 2 Read Register (BBFSYNCPOWRD2)**

Address: 0136H After reset: 80H R

Symbol	7	6	5	4	3	2	1	0
BBFSYNC POWRD2	FSYNCPOW RD27	FSYNCPOW RD26	FSYNCPOW RD25	FSYNCPOW RD24	FSYNCPOW RD23	FSYNCPOW RD22	FSYNCPOW RD21	FSYNCPOW RD20
	FSYNCPOWRD27 to FSYNCPOWRD20		Frame synchronization power value read					
	—		8-bit power value of the frame synchronization section in the frame being received					

### 4.2.112 RSSI read register (BBRSSIRD)

This register holds the RSSI value of the frame being received. The 10-bit power value at the start of reception is stored in the RSSIRD bits. The read value is a 2's complement indicating a value from -256.0 dBm to +255.5 dBm in steps of 0.5 dBm. The unit of indication is dBm. For example, 33DH indicates -97.5 dBm. The value of this register following a reset is 0200H.

**Figure 4-144 Format of RSSI Read Register (BBRSSIRD)**

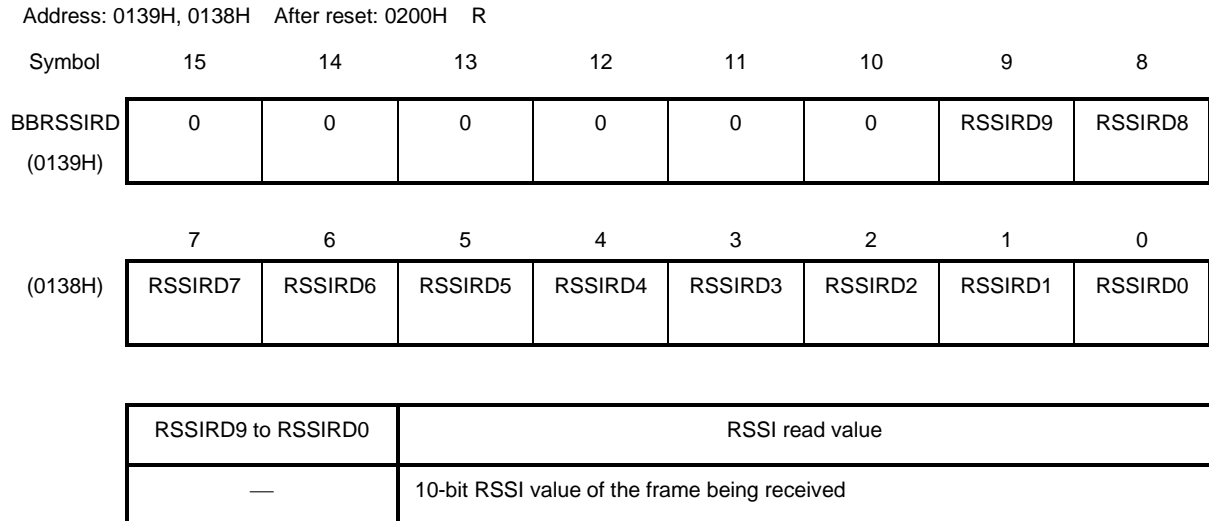



### 4.2.113 RCPI read register (BBRCPIRD)

This register holds the RCPI value of the frame being received. The 10-bit average of the received power values is stored in the RCPIRD bits. The read value is a 2's complement indicating a value from -256.0 dBm to +255.5 dBm in steps of 0.5 dBm. The unit of indication is dBm. For example, 33DH indicates -97.5 dBm. The value of this register following a reset is 0200H.

**Figure 4-145 Format of RCPI Read Register (BBRCPIRD)**

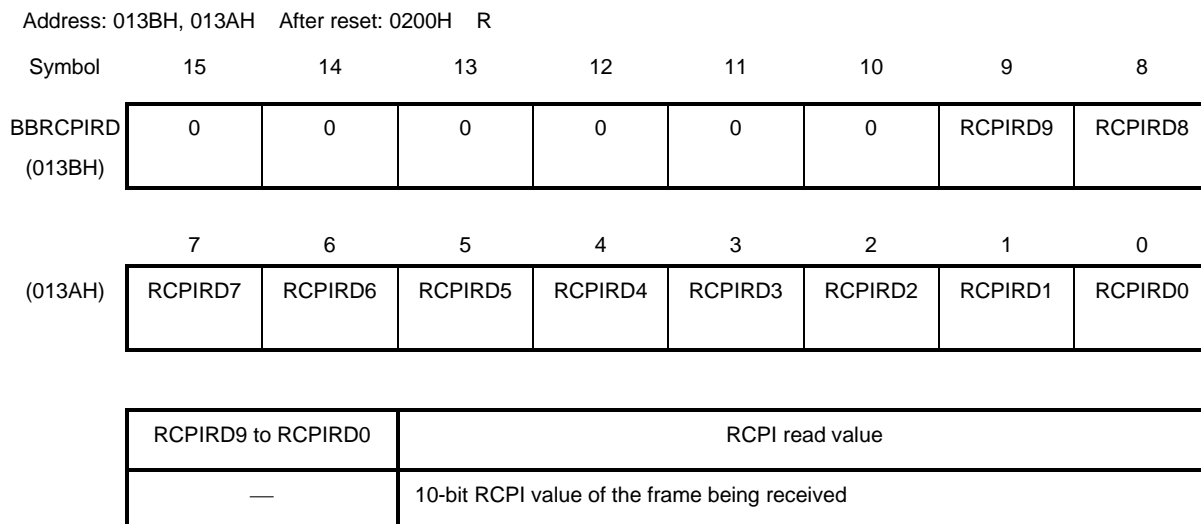

#### 4.2.114 RSSI read 2 register (BBRSSIRD2)

This register holds the RSSI value of the frame being received. The 8-bit power value at the start of reception is stored in the RSSIRD2 bits. The read value is a 2's complement indicating a value from -128 dBm to +127 dBm in steps of 1 dBm. The unit of indication is dBm. For example, 9EH indicates -98 dBm. The value of this register following a reset is 80H.

**Figure 4-146 Format of RSSI Read 2 Register (BBRSSIRD2)**

Address: 013CH After reset: 80H R

Symbol	7	6	5	4	3	2	1	0
BBRSSI	RSSIRD2	RSSIRD2	RSSIRD2	RSSIRD2	RSSIRD2	RSSIRD2	RSSIRD2	RSSIRD2
RD2	7	6	5	4	3	2	1	0

RSSIRD27 to RSSIRD20	RSSI read value
—	8-bit RSSI value of the frame being received

### 4.2.115 RCPI read 2 register (BBRCPIRD2)

This register holds the RCPI value of the frame being received. The 8-bit average of the received power values is stored in the RCPIRD2 bits. The read value is a 2's complement indicating a value from -128 dBm to +127 dBm in steps of 1 dBm. The unit of indication is dBm. For example, 9EH indicates -98 dBm. The value of this register following a reset is 80H.

**Figure 4-147 Format of RCPI Read 2 Register (BBRCPIRD2)**

Address: 013DH After reset: 80H R

Symbol            7            6            5            4            3            2            1            0

BBRCPI	RCPIRD2	RCPIRD2	RCPIRD2	RCPIRD2	RCPIRD2	RCPIRD2	RCPIRD2	RCPIRD2
RD2	7	6	5	4	3	2	1	0

RCPIRD27 to RCPIRD20	RCPI read value
—	8-bit RCPI value of the frame being received

### 4.2.116 Transmission and reception method selection register (BBTRXSEL)

The transmission method selection bit and reception method selection bit are used to select the transmission and reception methods, respectively. The CCA method selection bits select the CCA method. The value of this register following a reset is 00H.

**Figure 4-148 Format of Transmission and Reception Method Selection Register (BBTRXSEL)**

Address: 0140H After reset: 00H R/W

Symbol	7	6	5	4	3	2	1	0
BBTRXSEL	0	0	CCAMODE1	CCAMODE0	RXMODE1	RXMODE0	0	TXMODE

CCAMODE1	CCAMODE0	CCA method selection
0	0	FSK
0	1	OFDM
1	0	Setting prohibited
1	1	FSK and OFDM

RXMODE1	RXMODE0	Reception method selection
0	0	FSK
0	1	OFDM
1	0	Setting prohibited
1	1	FSK and OFDM

TXMODE	Transmission method selection
0	FSK
1	OFDM

**Caution** When writing to this register, set bits 7, 6, and 1 to the value 0.

### 4.2.117 Reception method check register (BBRXMODEMONI)

This register is used to check the current reception method. The reception method is stored in this register at the same time as the frame length value is stored. The reception method value corresponding to the save bank specified by the receive data save bank select bit is read from this register. The value of this register following a reset is 00H.

Figure 4-149 Format of Reception Method Check Register (BBRXMODEMONI)

Address: 0141H After reset: 00H R

Symbol	7	6	5	4	3	2	1	0
BBRXMODEMONI	0	0	0	0	0	0	0	RXMODE MONI

RXMODE MONI	Reception method check
0	FSK
1	OFDM

### 4.2.118 Reception prohibition register (BBRXPROHIBIT)

The reception prohibition bit is used to prohibit reception. The reception prohibition bit is set to 1 upon reception of every frame while the reception prohibition enable bit is set to 1. In this state, this device does not receive but discards the next frame and the MODEM circuit block is reset. To receive the next frame, clear the prohibition bit to 0. This bit can also be set to 1 by writing 1 to the bit. The reception prohibition enable bit enables the function of the reception prohibition bit. While the enable bit is set to 1, the prohibition bit can be used to prohibit reception. The value of this register following a reset is 00H.

**Figure 4-150 Format of Reception Prohibition Register (BBRXPROHIBIT)**

Address: 0142H After reset: 00H R/W

Symbol	7	6	5	4	3	2	1	0
BBRXPROHIBIT	0	0	0	0	0	0	RXPROHIBITEN	RXPROHIBIT

RXPROHIBITEN	Reception prohibition bit enable
0	Reception prohibition bit is disabled.
1	Reception prohibition bit is enabled.

RXPROHIBIT	Reception prohibition
0	Reception is allowed.
1	Reception is prohibited.

**Caution** When writing to this register, set bits 7 to 2 to the value 0.

### 4.2.119 Received frame counter control register (BBRCVCOUNTCNT)

The receive frame counter reset bit is used to reset the total reception counter, PHR error count register, number-of-successful-receptions counter, and number-of-unsuccessful-receptions counter to 00000000H together. After 1 is written, this bit is automatically cleared to 0. The counting of discarded frames by the PHR error counter can be enabled or disabled by the respective bits as follows.

MS discard count enable bit: Counting of discarded mode switch frames

Minimum value FL cancellation count enable bit: Counting of received frames discarded due to the frame length equal to or smaller than the value specified in the frame cancellation minimum length register

Maximum value FL cancellation count enable bit: Counting of received frames discarded due to the frame length equal to or greater than the value specified in the frame cancellation maximum length register

MS error count enable bit: Counting of received mode switch frames including a PC error

HCS error count enable bit: Counting of received frames including an HCS check error in the PHR, which is detected by the MODEM block

The value of this register following a reset is 00H.

**Figure 4-151 Format of Received Frame Counter Control Register (BBRCVCOUNTCNT) (1/2)**

Address: 0143H After reset: 00H R/W

Symbol	7	6	5	4	3	2	1	0
BBRCVCO UNTCNT	0	0	HCSERR COUNTEN	MSERR COUNTEN	FLMAX COUNTEN	FLMIN COUNTEN	MS COUNTEN	RCV COUNTRST

HCSERR COUNTEN	HCS error count enable
0	Counting is disabled.
1	Counting is enabled.

MSERR COUNTEN	MS error count enable
0	Counting is disabled.
1	Counting is enabled.

FLMAX COUNTEN	Maximum value FL cancellation count enable
0	Counting is disabled.
1	Counting is enabled.

Figure 4-152 Format of Received Frame Counter Control Register (BBRCVCOUNTCNT) (2/2)

FLMIN COUNTEN	Minimum value FL cancellation count enable
0	Counting is disabled.
1	Counting is enabled.

MS COUNTEN	MS discard count enable
0	Counting is disabled.
1	Counting is enabled.

RCV COUNTRST	Receive frame counter reset
0	No operation
1	Counters are reset.

**Caution** When writing to this register, set bits 7 and 6 to the value 0.



### 4.2.120 Total reception counter (BBRCVCOUNT)

This counter indicates the total number of received frames from which frame synchronization is detected. When the value read from the lowest-order byte at address 0144H is 00H in a state other than IDLE, re-read from the lowest-order byte at the given address. Note that re-reading from the lowest-order byte should be done before the counter has counted to 256 so that the value of the lowest-order byte becomes 00H. This counter can be reset by setting the receive frame counter reset bit. The value of this register following a reset is 00000000H.

**Figure 4-153 Format of Total Reception Counter (BBRCVCOUNT)**

Address: 0147H to 0144H After reset: 00000000H R

Symbol	31	30	29	28	27	26	25	24
BBRCV COUNT (0147H)	RCVCOUNT 31	RCVCOUNT 30	RCVCOUNT 29	RCVCOUNT 28	RCVCOUNT 27	RCVCOUNT 26	RCVCOUNT 25	RCVCOUNT 24
	23	22	21	20	19	18	17	16
(0146H)	RCVCOUNT 23	RCVCOUNT 22	RCVCOUNT 21	RCVCOUNT 20	RCVCOUNT 19	RCVCOUNT 18	RCVCOUNT 17	RCVCOUNT 16
	15	14	13	12	11	10	9	8
(0145H)	RCVCOUNT 15	RCVCOUNT 14	RCVCOUNT 13	RCVCOUNT 12	RCVCOUNT 11	RCVCOUNT 10	RCVCOUNT 9	RCVCOUNT 8
	7	6	5	4	3	2	1	0
(0144H)	RCVCOUNT 7	RCVCOUNT 6	RCVCOUNT 5	RCVCOUNT 4	RCVCOUNT 3	RCVCOUNT 2	RCVCOUNT 1	RCVCOUNT 0
	RCVCOUNT31 to RCVCOUNT0		Total number of received frames					
	—		These bits indicate the total number of received frames.					

### 4.2.121 PHR error counter (BBPHRERRCOUNT)

This counter indicates the number of the received frames that are discarded as a result of the PHR validation. The frames that match the following check conditions are counted. Each check can be enabled or disabled individually.

- Received frames whose MS bit is set to 1 when the MS frame discard bit is set to 1 (frame is discarded).
- Received frames that are discarded because the frame length value is equal to or smaller than the value specified in the frame cancellation minimum length register
- Received frames that are discarded because the frame length value is equal to or greater than the value specified in the frame cancellation maximum length register
- Received mode switch frames that include a PC error
- Received frames that include an HCS check error in the PHR, which is detected in the MODEM block.

When the value read from the lowest-order byte at address 0148H is 00H in a state other than IDLE, re-read from the lowest-order byte at the given address. Note that re-reading from the lowest-order byte should be done before the counter has counted to 256 so that the value of the lowest-order byte becomes 00H. The value of this register following a reset is 00000000H.

**Figure 4-154 Format of PHR Error Counter (BBPHRERRCOUNT)**

Address: 014BH to 0148H After reset: 00000000H R

Symbol	31	30	29	28	27	26	25	24
BBPHRERRCOUNT (014BH)	PHRERR COUNT31	PHRERR COUNT30	PHRERR COUNT29	PHRERR COUNT28	PHRERR COUNT27	PHRERR COUNT26	PHRERR COUNT25	PHRERR COUNT24
	23	22	21	20	19	18	17	16
(014AH)	PHRERR COUNT23	PHRERR COUNT22	PHRERR COUNT21	PHRERR COUNT20	PHRERR COUNT19	PHRERR COUNT18	PHRERR COUNT17	PHRERR COUNT16
	15	14	13	12	11	10	9	8
(0149H)	PHRERR COUNT15	PHRERR COUNT14	PHRERR COUNT13	PHRERR COUNT12	PHRERR COUNT11	PHRERR COUNT10	PHRERR COUNT9	PHRERR COUNT8
	7	6	5	4	3	2	1	0
(0148H)	PHRERR COUNT7	PHRERR COUNT6	PHRERR COUNT5	PHRERR COUNT4	PHRERR COUNT3	PHRERR COUNT2	PHRERR COUNT1	PHRERR COUNT0
	PHRERRCOUNT31 to PHRERRCOUNT0							
	Number of PHR errors							
	—							
	These bits indicate the number of the received frames that are discarded as a result of the PHR validation.							

### 4.2.122 Number-of-successful-receptions counter (BBRCVOKCOUNT)

This register is used to count the number of frames that have been successfully received after having passed the PHR and CRC validations. When the value read from the lowest-order byte at address 014CH is 00H in a state other than IDLE, re-read from the lowest-order byte at the given address. Note that re-reading from the lowest-order byte should be done before the counter has counted to 256 so that the value of the lowest-order byte becomes 00H. The value of this register following a reset is 00000000H.

**Figure 4-155 Format of Number-of-Successful-Receptions Counter (BBRCVOKCOUNT)**

Address: 014FH to 014CH After reset: 00000000H R

Symbol	31	30	29	28	27	26	25	24
BBRCVOK COUNT (014FH)	RCVOK COUNT31	RCVOK COUNT30	RCVOK COUNT29	RCVOK COUNT28	RCVOK COUNT27	RCVOK COUNT26	RCVOK COUNT25	RCVOK COUNT24
	23	22	21	20	19	18	17	16
(014EH)	RCVOK COUNT23	RCVOK COUNT22	RCVOK COUNT21	RCVOK COUNT20	RCVOK COUNT19	RCVOK COUNT18	RCVOK COUNT17	RCVOK COUNT16
	15	14	13	12	11	10	9	8
(014DH)	RCVOK COUNT15	RCVOK COUNT14	RCVOK COUNT13	RCVOK COUNT12	RCVOK COUNT11	RCVOK COUNT10	RCVOK COUNT9	RCVOK COUNT8
	7	6	5	4	3	2	1	0
(014CH)	RCVOK COUNT7	RCVOK COUNT6	RCVOK COUNT5	RCVOK COUNT4	RCVOK COUNT3	RCVOK COUNT2	RCVOK COUNT1	RCVOK COUNT0
	RCVOKCOUNT31 to RCVOKCOUNT0							
	Number-of-successful-receptions counter value							
	—							
	These bits indicate the number of frames that have been successfully received by this device.							

### 4.2.123 Number-of-unsuccessful-receptions counter (BBRCVNGCOUNT)

This register is used to count the number of frames that have been unsuccessfully received after having passed the PHR validation but failed the CRC validation. When the value read from the lowest-order byte at address 0150H is 00H in a state other than IDLE, re-read from the lowest-order byte at the given address. Note that re-reading from the lowest-order byte should be done before the counter has counted to 256 so that the value of the lowest-order byte becomes 00H. The value of this register following a reset is 00000000H.

**Figure 4-156 Format of Number-of-Unsuccessful-Receptions Counter (BBRCVNGCOUNT)**

Address: 0153H to 0150H After reset: 00000000H R

Symbol	31	30	29	28	27	26	25	24
BBRCVNG COUNT (0153H)	RCVNG COUNT31	RCVNG COUNT30	RCVNG COUNT29	RCVNG COUNT28	RCVNG COUNT27	RCVNG COUNT26	RCVNG COUNT25	RCVNG COUNT24
	23	22	21	20	19	18	17	16
(0152H)	RCVNG COUNT23	RCVNG COUNT22	RCVNG COUNT21	RCVNG COUNT20	RCVNG COUNT19	RCVNG COUNT18	RCVNG COUNT17	RCVNG COUNT16
	15	14	13	12	11	10	9	8
(0151H)	RCVNG COUNT15	RCVNG COUNT14	RCVNG COUNT13	RCVNG COUNT12	RCVNG COUNT11	RCVNG COUNT10	RCVNG COUNT9	RCVNG COUNT8
	7	6	5	4	3	2	1	0
(0150H)	RCVNG COUNT7	RCVNG COUNT6	RCVNG COUNT5	RCVNG COUNT4	RCVNG COUNT3	RCVNG COUNT2	RCVNG COUNT1	RCVNG COUNT0
	RCVNGCOUNT31 to RCVNGCOUNT0							
	Number-of-unsuccessful-receptions counter value							
	—							
	These bits indicate the number of frames that have been unsuccessfully received by this device.							

#### 4.2.124 Frame synchronization power value result register (BBFSYNCPOWRSLT)

This register holds the power value of the frame synchronization section. The 10-bit power value of the frame synchronization section is stored in the FSYNCPOWRSLT bits. The receive level filter function uses this power value. The power value of the frame synchronization section corresponding to the save bank specified by the receive data save bank select bit is read from this register. The read value is a 2's complement indicating a value from -256.0 dBm to +255.5 dBm in steps of 0.5 dBm. The unit of indication is dBm. For example, 33DH indicates -97.5 dBm. The value of this register following a reset is 0200H.

**Figure 4-157 Format of Frame Synchronization Power Value Result Register (BBFSYNCPOWRSLT)**

Address: 0159H, 0158H After reset: 0200H R

Symbol	15	14	13	12	11	10	9	8
BBFSYNC POWRSLT (0159H)	0	0	0	0	0	0	FSYNCPOW RSLT9	FSYNCPOW RSLT8
	7	6	5	4	3	2	1	0
(0158H)	FSYNCPOW RSLT7	FSYNCPOW RSLT6	FSYNCPOW RSLT5	FSYNCPOW RSLT4	FSYNCPOW RSLT3	FSYNCPOW RSLT2	FSYNCPOW RSLT1	FSYNCPOW RSLT0
	FSYNCPOWRSLT9 to FSYNCPOWRSLT0		Frame synchronization power value					
	—		10-bit power value of the frame synchronization section					

#### 4.2.125 Frame synchronization power value result 2 register (BBFSYNCPOWRSLT2)

This register holds the power value of the frame synchronization section. The 8-bit power value of the frame synchronization section is stored in the FSYNCPOWRSLT2 bits. The power value of the frame synchronization section corresponding to the save bank specified by the receive data save bank select bit is read from this register. The read value is a 2's complement indicating a value from -128 dBm to +127 dBm in steps of 1 dBm. The unit of indication is dBm. For example, 9EH indicates -98 dBm. The value of this register following a reset is 80H.

**Figure 4-158 Format of Frame Synchronization Power Value Result 2 Register (BBFSYNCPOWRSLT2)**

Address: 015AH After reset: 80H R

Symbol	7	6	5	4	3	2	1	0
BBFSYNCP OWRSLT2	FSYNCPOW RSLT27	FSYNCPOW RSLT26	FSYNCPOW RSLT25	FSYNCPOW RSLT24	FSYNCPOW RSLT23	FSYNCPOW RSLT22	FSYNCPOW RSLT21	FSYNCPOW RSLT20
	FSYNCPOWRSLT27 to FSYNCPOWRSLT20		Frame synchronization power value					
	—		8-bit power value of the frame synchronization section					

#### 4.2.126 CCA data rate control register (BBCCARATECON)

The data rate for CCA can be set independently of that for transmission and reception by setting the CCA data rate switching bit. While the setting of this bit is 1, the following settings are effective.

- The CCAFSK modulation index setting bit is used to specify the modulation index for CCA in the FSK modulation mode.
- The data rate for CCA in the FSK modulation mode can be selected by the CCAFSK data rate selection bits.
- The CCAOFDMOPTION setting bits are used to set the option value for CCA in the OFDM modulation mode.

The value of this register following a reset is 00H.

**Figure 4-159 Format of CCA Data Rate Control Register (BBCCARATECON) (1/2)**

Address: 015EH After reset: 00H R/W

Symbol	7	6	5	4	3	2	1	0
BBCCA RATECON	CCAOFDM OPTION1	CCAOFDM OPTION0	CCAFSK RATE3	CCAFSK RATE2	CCAFSK RATE1	CCAFSK RATE0	CCAFSK INDEX	CCADATA RATESEL

CCAOFDM OPTION1	CCAOFDM OPTION0	CCAOFDMOPTION setting
0	0	Option 1
0	1	Option 2
1	0	Option 3
1	1	Option 4

CCAFSK RATE3	CCAFSK RATE2	CCAFSK RATE1	CCAFSK RATE0	CCAFSK data rate selection
0	0	0	0	50 kbps
0	0	0	1	100 kbps
0	0	1	0	150 kbps
0	0	1	1	200 kbps
0	1	0	0	10 kbps
0	1	0	1	20 kbps
0	1	1	0	Setting prohibited
0	1	1	1	Setting prohibited
1	0	0	0	9.6 kbps
1	0	0	1	19.2 kbps
1	0	1	0	38.4 kbps
1	0	1	1	115.2 kbps
1	1	0	0	Setting prohibited
1	1	0	1	Setting prohibited
1	1	1	0	Setting prohibited
1	1	1	1	Setting prohibited

Figure 4-160 Format of CCA Data Rate Control Register (BBCCARATECON) (2/2)

CCAFS KINDEX	CCAFSK modulation index setting
0	0.5
1	1.0

CCADATA RATESEL	CCA data rate switching
0	The data rate for CCA is same as that for transmission and reception.
1	The data rate for CCA can be set independently of that for transmission and reception.



### 4.2.127 FSK control register 0 (BBFSKCON0)

The FSK modulation index setting bit is used to specify the modulation index for FSK transmission and reception. The rate of FSK data transmission and reception can be selected by the FSK data rate selection bits. The value of this register following a reset is 00H.

Figure 4-161 Format of FSK Control Register 0 (BBFSKCON0)

Address: 0160H After reset: 00H R/W

Symbol	7	6	5	4	3	2	1	0
BBFSK CON0	0	0	0	FSK RATE3	FSK RATE2	FSK RATE1	FSK RATE0	FSK INDEX

FSK RATE3	FSK RATE2	FSK RATE1	FSK RATE0	FSK data rate selection
0	0	0	0	50 kbps
0	0	0	1	100 kbps
0	0	1	0	150 kbps
0	0	1	1	200 kbps
0	1	0	0	10 kbps
0	1	0	1	20 kbps
0	1	1	0	Setting prohibited
0	1	1	1	Setting prohibited
1	0	0	0	9.6 kbps
1	0	0	1	19.2 kbps
1	0	1	0	38.4 kbps
1	0	1	1	115.2 kbps
1	1	0	0	Setting prohibited
1	1	0	1	Setting prohibited
1	1	1	0	Setting prohibited
1	1	1	1	Setting prohibited

FSK INDEX	FSK modulation index setting
0	0.5
1	1.0

**Caution** When writing to this register, set bits 7 to 5 to the value 0.

### 4.2.128 FSK control register 1 (BBFSKCON1)

The FSK reception FEC enable bit enables FEC for reception. The FSKFEC mode switch bit is used to switch the mode of FEC encoding. The FSKCRC bit count switch bit selects the number of CRC calculation bits for FSK transmission. For auto ACK reply, the number of CRC bits in the received frame is used. The FSKDW enable bit enables data whitening for transmission. The FSKPHR transmission 1 and 2 bits are used to specify the values of bits 1 and 2 of the PHR for FSK transmission, respectively. The FSK interleaving enable bit enables interleaving. Be sure to set this bit to 1 when using the NRNSC encoder. When using the RSC encoder, interleaving can be enabled or disabled as desired. The reception MS bit forcible clear bit is used to forcibly clear the received MS bit to 0. The value of this register following a reset is 8CH.

**Figure 4-162 Format of FSK Control Register 1 (BBFSKCON1) (1/2)**

Address: 0161H After reset: 8CH R/W

Symbol	7	6	5	4	3	2	1	0
BBFSK CON1	RXFORCE MS	FSK INTLVEN	FSKPHR TX2	FSKPHR TX1	FSKDW EN	FSKCRC BIT	FSKFEC MODE	FSKFEC ENRX

RXFORCE MS	Reception MS bit forcible clear
0	The MS bit is not forcibly cleared to 0.
1	The MS bit is forcibly cleared to 0.

FSK INTLVEN	FSK interleaving enable
0	Interleaving is disabled.
1	Interleaving is enabled.

FSKPHR TX2	FSKPHR transmission 2
—	Value to be transmitted.

FSKPHR TX1	FSKPHR transmission 1
—	Value to be transmitted.

Figure 4-163 Format of FSK Control Register 1 (BBFSKCON1) (2/2)

FSKDW EN	FSKDW enable
0	Data whitening is disabled.
1	Data whitening is enabled.

FSKCRC BIT	FSKCRC bit count switch
0	32-bit CRC
1	16-bit CRC

FSKFEC MODE	FSKFEC mode switch
0	NRNSC encoder
1	RSC encoder

FSKFEC ENRX	FSK reception FEC enable
0	FEC is disabled.
1	FEC is enabled.

### 4.2.129 FSK control register 2 (BBFSKCON2)

The GFSK/FSK switch bits for transmission and reception are used to switch between GFSK modulation and FSK modulation for transmission and reception, respectively. The value of this register following a reset is 00H.

**Figure 4-164 Format of FSK Control Register 2 (BBFSKCON2)**

Address: 0162H After reset: 00H R/W

Symbol	7	6	5	4	3	2	1	0
BBFSK CON2	0	0	0	0	0	0	RXFSKSEL	TXFSKSEL

RXFSKSEL	GFSK/FSK switch for reception
0	GFSK
1	FSK

TXFSKSEL	GFSK/FSK switch for transmission
0	GFSK
1	FSK

**Caution** When writing to this register, set bits 7 to 2 to the value 0.

### 4.2.130 FSKFEC control register (BBFSKFECCON)

The automatic FEC detection enable bit is used to detect whether FEC is enabled in reception. The transmission FEC enable bit enables or disables FEC for transmission. The auto ACK reply FEC control bit selects whether the enabling of FEC in auto ACK reply depends on the FEC state (enabled or disabled) in reception or the setting of the auto ACK reply FEC enable bit. When the auto ACK reply FEC control bit is set to 1, FEC in auto ACK reply can be enabled or disabled by the auto ACK reply FEC enable bit. The auto ACK receive FEC control bit selects whether the enabling of FEC in auto ACK reception depends on the setting of the auto ACK receive FEC enable bit. When the auto ACK receive FEC control bit is set to 1, FEC in auto ACK reception can be enabled or disabled by the auto ACK receive FEC enable bit. The MRFSKSFD selection bit is used to specify the phyMRFSKSFD value. The reception FEC monitor bit is used to monitor whether FEC is enabled in the received frame. The value of this register following a reset is 00H.

Figure 4-165 Format of FSKFEC Control Register (BBFSKFECCON) (1/2)

Address: 0163H After reset: 00H R/W<sup>Note</sup>

Symbol	7	6	5	4	3	2	1	0
BBFSKFEC CON	FECMONI	MRFSKSFD	FECEN ACKRCV	FECCON ACKRCV	FECEN ACKRTN	FECCON ACKRTN	FEC ENTX	FEC AUTOEN

FECMONI	Reception FEC monitor
0	Reception without FEC
1	Reception with FEC

MRFSKSFD	MRFSKSFD selection
0	phyMRFSKSFD = 0
1	phyMRFSKSFD = 1

FECEN ACKRCV	Auto ACK receive FEC enable
0	FEC is disabled.
1	FEC is enabled.

FECCON ACKRCV	Auto ACK receive FEC control
0	FEC does not depend on the setting of the auto ACK receive FEC enable bit.
1	FEC depends on the setting of the auto ACK receive FEC enable bit.

Figure 4-166 Format of FSKFEC Control Register (BBFSKFECCON) (2/2)

FECEN ACKRTN	Auto ACK reply FEC enable
0	FEC is disabled.
1	FEC is enabled.

FECCON ACKRTN	Auto ACK reply FEC control
0	FEC depends on the FEC enabled or disabled state in reception.
1	FEC depends on the setting of the auto ACK reply FEC enable bit.

FEC ENTX	Transmission FEC enable
0	FEC is disabled.
1	FEC is enabled.

FEC AUTOEN	Automatic FEC detection enable
0	Automatic detection is disabled.
1	Automatic detection is enabled.

**Caution** Writing to bit 7 has no effect.

### 4.2.131 Mode switch frame transmission register (BBTXMODESW)

The mode switch enable bit enables the transmission of the mode switch frame. Setting this bit to 1 and then setting the transmit trigger to 1 transmits the mode switch frame. Only set this bit to 1 for FSK modulation; do not set to 1 for OFDM modulation. Also set the FSKCRC bit count switch bit (FSKCRCBIT) in the FSK control register 1 (BBFSKCON1) to 1. TXMODESW1 to TXMODESW15 bits are used to specify PHR bits 1 to 15 of the mode switch frame to be transmitted. The value of this register following a reset is 0000H.

**Figure 4-167 Format of Mode Switch Frame Transmission Register (BBTXMODESW)**

Address: 0165H, 0164H After reset: 0000H R/W

Symbol	15	14	13	12	11	10	9	8
BBTXMODESW (0165H)	TXMODE SW15	TXMODE SW14	TXMODE SW13	TXMODE SW12	TXMODE SW11	TXMODE SW10	TXMODE SW9	TXMODE SW8
	7	6	5	4	3	2	1	0
(0164H)	TXMODE SW7	TXMODE SW6	TXMODE SW5	TXMODESW W4	TXMODE SW3	TXMODE SW2	TXMODE SW1	MODESW
TXMODE SW15 to 1	TXMODESW							
—	Value of PHR bits 1 to 15 of the mode switch frame to be transmitted							
MODESW	Mode switch enable							
0	Disabled, i.e., frames other than mode switch frames are transmitted.							
1	Enabled, i.e., the mode switch frame is transmitted.							

### 4.2.132 Mode switch frame reception register (BBRXMODESW)

This register holds the PHY header data (PHR) when a mode switch frame is received. The stored data is retained until the start of the next reception of a mode switch frame. The value of this register following a reset is 0000H.

**Figure 4-168 Format of Mode Switch Frame Reception Register (BBRXMODESW)**

Address: 0167H, 0166H After reset: 0000H R

Symbol	15	14	13	12	11	10	9	8
BBRXMOD	RXMODE	RXMODE	RXMODE	RXMODE	RXMODE	RXMODE	RXMODE	RXMODE
ESW	SW15	SW14	SW13	SW12	SW11	SW10	SW9	SW8
(0167H)								
	7	6	5	4	3	2	1	0
(0166H)	RXMODE	RXMODE	RXMODE	RXMODE	RXMODE	RXMODE	RXMODE	RXMODE
	SW7	SW6	SW5	SW4	SW3	SW2	SW1	SW0
	RXMODESW15 to RXMODESW0		RXMODESW					
	—		Value of PHR bits 0 to 15 of the received mode switch frame					



### 4.2.133 Mode switch status register (BBMSSTATE)

The BCH syndrome calculation result bit is used to check the result of BCH syndrome calculation for the received mode switch frame. The PC error flag is used to check whether a PC error has been found in the received mode switch frame. The received mode switch bit is used to check the value of the mode switch in the received mode switch frame. The value of this register following a reset is 00000X00B.

**Figure 4-169 Format of Mode Switch Status Register (BBMSSTATE)**

Address: 0168H After reset: 00000X00B R

Symbol	7	6	5	4	3	2	1	0
BBMS STATE	0	0	0	0	0	MSFLD	PCERRFLG	BCHSYND

MSFLD	Received mode switch
—	Value of the mode switch in the received mode switch frame

PCERRFLG	PC error flag
0	No PC error has been found.
1	A PC error has been found.

BCHSYND	BCH syndrome calculation result
0	Result of BCH syndrome calculation = 0
1	Result of BCH syndrome calculation = 1

### 4.2.134 Mode switch frame control register (BBMSCON)

The parity check target bits setting bit is used to set the range of bits in received mode switch frames to be parity checked. The value of this register following a reset is 00H.

**Figure 4-170 Format of Mode Switch Frame Control Register (BBMSCON)**

Address: 0169H After reset: 00H R/W

Symbol	7	6	5	4	3	2	1	0
BBMSCON	0	0	0	0	0	0	0	PCSEL

PCSEL	Parity check target bits setting
0	Bits 0 to 10 are to be parity checked.
1	Bits 0 to 14 are to be parity checked.

**Caution** When writing to this register, set bits 7 to 1 to the value 0.

### 4.2.135 FSKCCA level threshold setting register (BBFSKCCA VTH)

This register is used to set the threshold level for CCA in FSK modulation. The frequency channel is judged to be busy when the CCA value is equal to or greater than the setting in this register. This device compares the receive level with the threshold in 10 bits; bits 9 to 0 of this register are used and bit 9 is the sign bit. Specify a value in 2's complement representation. The unit of setting is dBm. For example, 33DH indicates -97.5 dBm. The value of this register following a reset is 0200H.

**Figure 4-171 Format of FSKCCA Level Threshold Setting Register (BBFSKCCA VTH)**

Address: 016BH, 016AH After reset: 0200H R/W

	Symbol	15	14	13	12	11	10	9	8
BBFSKCCA VTH (016BH)		0	0	0	0	0	0	FSKCCA VTH9	FSKCCA VTH8
(016AH)		7	6	5	4	3	2	1	0
		FSKCCA VTH7	FSKCCA VTH6	FSKCCA VTH5	FSKCCA VTH4	FSKCCA VTH3	FSKCCA VTH2	FSKCCA VTH1	FSKCCA VTH0
		FSKCCA VTH9 to FSKCCA VTH0		FSKCCA threshold					
		—		Threshold level for CCA in FSK modulation					

**Caution** When writing to this register, set bits 15 to 10 to the value 0.

### 4.2.136 FSK reception level threshold setting register (BBFSKLVLVTH)

This register is used to set the threshold value for the receive level filter function in FSK modulation. Reception is done for the level higher than the specified value. This device compares the receive level with the threshold in 10 bits; bits 9 to 0 of this register are used and bit 9 is the sign bit. Specify a value in 2's complement representation. The unit of setting is dBm. For example, 33DH indicates -97.5 dBm. The value of this register following a reset is 0200H.

**Figure 4-172 Format of FSK Reception Level Threshold Setting Register (BBFSKLVLVTH)**

Address: 016DH, 016CH After reset: 0200H R/W

Symbol	15	14	13	12	11	10	9	8
BBFSKLVL VTH (016DH)	0	0	0	0	0	0	FSKLVL VTHT9	FSKLVL VTHT8
(016CH)	7	6	5	4	3	2	1	0
	FSKLVL VTHT7	FSKLVL VTHT6	FSKLVL VTHT5	FSKLVL VTHT4	FSKLVL VTHT3	FSKLVL VTHT2	FSKLVL VTHT1	FSKLVL VTHT0
FSKLVLVTHT9 to FSKLVLVTHT0		FSK receive level threshold						
—		Threshold value for the receive level filter function in FSK modulation						

**Caution** When writing to this register, set bits 15 to 10 to the value 0.

### 4.2.137 FSKPHR reception register (BBFSKPHRRX)

This register holds the values of bits 0 to 4 of the PHY header data when a non-mode switch frame is received. The timing of the storage in this register is the same as the timing when the frame length value is stored. The values corresponding to the save bank specified by the receive data save bank select bit is read from this register. The value of this register following a reset is 0200H.

**Figure 4-173 Format of FSKPHR Reception Register (BBFSKPHRRX)**

Address: 016EH After reset: 00H R

Symbol	7	6	5	4	3	2	1	0
BBFSKPHRRX	0	0	0	FSKPHRRX 4	FSKPHRRX 3	FSKPHRRX 2	FSKPHRRX 1	FSKPHRRX 0

FSKPHRRX 4	FSKPHR reception 4
—	Received value (DW)

FSKPHRRX 3	FSKPHR reception 3
—	Received value (FCS)

FSKPHRRX 2	FSKPHR reception 2
—	Received value (Reserved)

FSKPHRRX 1	FSKPHR reception 1
—	Received value (Reserved)

FSKPHRRX 0	FSKPHR reception 0
—	Received value (MS)

### 4.2.138 OFDM control register (BBOFDMCON)

The number-of-OFDMCRC-bit switch bit selects the number of bits for the CRC calculation process in OFDM transmission or reception. The OFDMOPTION setting bits are used to set the option value for OFDM transmission or reception. The OFDM interleaving setting bit is used to set the interleaving value for OFDM transmission or reception. The OFDM extended mode bit is used to select an internal setting for OFDM modulation. When any of option-3 MCS0, option-4 MCS0, or option-4 MCS1 is selected, set this bit to 1. Otherwise, set this bit to 0. The value of this register following a reset is 00H.

Figure 4-174 Format of OFDM Control Register (BBOFDMCON)

Address: 0170H After reset: 00H R/W

Symbol	7	6	5	4	3	2	1	0
BBOFDM CON	0	0	0	OFDMEXT	OFDMINTER LEAVING	OFDM OPTION1	OFDM OPTION0	OFDM CRCBIT

OFDMEXT	OFDM extended mode
0	For other cases than those described below
1	For option-3 MCS0, option-4 MCS0, and option-4 MCS1

OFDMINTER LEAVING	OFDM interleaving setting
—	Interleaving value

OFDM OPTION1	OFDM OPTION0	OFDMOPTION setting
0	0	Option 1
0	1	Option 2
1	0	Option 3
1	1	Option 4

OFDM CRCBIT	Number-of-OFDMCRC-bit switch
0	32-bit CRC
1	16-bit CRC

**Caution** When writing to this register, set bits 7 to 5 to the value 0.

### 4.2.139 OFDMPHR transmission register 0 (BBOFDMPHRTX0)

The OFDMMCSTX setting bits are used to specify the MCS value for OFDM transmission. Specify the values of bits 4 to 2 of the PHR for OFDM transmission in the OFDMMCSTX0 to OFDMMCSTX2 bits, respectively. The OFDMSCBTX setting bits are used to specify the scrambler value for OFDM transmission. Specify the values of bits 20 and 19 of the PHR for OFDM transmission in the OFDMSCBTX0 and OFDMSCBTX1 bits, respectively. Note the correspondence of bit positions between the PHR and this register. The value of this register following a reset is 00H.

**Figure 4-175 Format of OFDMPHR Transmission Register 0 (BBOFDMPHRTX0)**

Address: 0172H After reset: 00H R/W

Symbol	7	6	5	4	3	2	1	0
BBOFDMPHRTX0	0	0	0	OFDM SCBTX1	OFDM SCBTX0	OFDM MCSTX2	OFDM MCSTX1	OFDM MCSTX0

OFDMSCBTX1, OFDMSCBTX0	OFDMSCBTX setting
—	Scrambler value

OFDMMCSTX2 to OFDMMCSTX0	OFDMMCSTX setting
—	MCS value

**Caution** When writing to this register, set bits 7 to 5 to the value 0.

#### 4.2.140 OFDMPHR transmission register 1 (BBOFDMPHRTX1)

Specify the values of bits 5, 17, 18, and 21 of the PHR for OFDM transmission in the OFDMPHRTX5, OFDMPHRTX17, OFDMPHRTX18, and OFDMPHRTX21 bits, respectively. The value of this register following a reset is 00H.

**Figure 4-176 Format of OFDMPHR Transmission Register 1 (BBOFDMPHRTX1)**

Address: 0173H After reset: 00H R/W

Symbol	7	6	5	4	3	2	1	0
BBOFDMPHRTX1	0	0	OFDM PHRTX21	OFDM PHRTX18	OFDM PHRTX17	OFDM PHRTX5	0	0

OFDM PHRTX21	OFDMPHR transmission 21
—	Value to be transmitted

OFDM PHRTX18	OFDMPHR transmission 18
—	Value to be transmitted

OFDM PHRTX17	OFDMPHR transmission 17
—	Value to be transmitted

OFDM PHRTX5	OFDMPHR transmission 5
—	Value to be transmitted

**Caution** When writing to this register, set bits 7, 6, 1, and 0 to the value 0.



#### 4.2.141 OFDMPHRACK reply register 0 (BBOFDMPHRACK0)

The OFDMMCSACK setting bits are used to specify the MCS value in the PHR for OFDM auto ACK reply. Specify the values of bits 4 to 2 of the PHR for OFDM auto ACK reply in the OFDMMCSACK0 to OFDMMCSACK2 bits, respectively. The OFDMSCBACK setting bits are used to specify the scrambler value in the PHR for OFDM auto ACK reply. Specify the values of bits 20 and 19 of the PHR for OFDM auto ACK reply in the OFDMSCBACK0 and OFDMSCBACK1 bits, respectively. Note the correspondence of bit positions between the PHR and this register. The value of this register following a reset is 00H.

**Figure 4-177 Format of OFDMPHRACK Reply Register 0 (BBOFDMPHRACK0)**

Address: 0174H After reset: 00H R/W

Symbol	7	6	5	4	3	2	1	0
BBOFDMPHRACK0	0	0	0	OFDM SCBACK1	OFDM SCBACK0	OFDM MCSACK2	OFDM MCSACK1	OFDM MCSACK0

OFDMSCBACK1, OFDMSCBACK0	OFDMSCBACK setting
—	Scrambler value

OFDMMCSACK2 to OFDMMCSACK0	OFDMMCSACK setting
—	MCS value

**Caution** When writing to this register, set bits 7 to 5 to the value 0.

#### 4.2.142 OFDMPHRACK reply register 1 (BBOFDMPHRACK1)

Specify the values of bits 5, 17, 18, and 21 of the PHR for OFDM auto ACK reply in the OFDMPHRACK5, OFDMPHRACK17, OFDMPHRACK18, and OFDMPHRACK21 bits, respectively. The value of this register following a reset is 00H.

**Figure 4-178 Format of OFDMPHRACK Reply Register 1 (BBOFDMPHRACK1)**

Address: 0175H After reset: 00H R/W

Symbol	7	6	5	4	3	2	1	0
BBOFDMPHRACK1	0	0	OFDM PHRACK21	OFDM PHRACK18	OFDM PHRACK17	OFDM PHRACK5	0	0

OFDM PHRACK21	OFDMPHRACK reply 21
—	Value to be transmitted

OFDM PHRACK18	OFDMPHRACK reply 18
—	Value to be transmitted

OFDM PHRACK17	OFDMPHRACK reply 17
—	Value to be transmitted

OFDM PHRACK5	OFDMPHRACK reply 5
—	Value to be transmitted

**Caution** When writing to this register, set bits 7, 6, 1, and 0 to the value 0.

### 4.2.143 OFDMPHR reception register 0 (BBOFDMPHRRX0)

This register holds the values of bits 2 to 5 of the PHY header data when an OFDM frame is received. The timing of the storage in this register is the same as the timing when the frame length value is stored. The values corresponding to the save bank specified by the receive data save bank select bit is read from this register. The value of this register following a reset is 00H.

Figure 4-179 Format of OFDMPHR Reception Register 0 (BBOFDMPHRRX0)

Address: 0176H After reset: 00H R

Symbol	7	6	5	4	3	2	1	0
BBOFDMPHRRX0	0	0	OFDM PHRRX5	OFDM PHRRX4	OFDM PHRRX3	OFDM PHRRX2	0	0

OFDM PHRRX5	OFDMPHR reception 5
—	Received value (Reserved)

OFDM PHRRX4	OFDMPHR reception 4
—	Received value (RATE0)

OFDM PHRRX3	OFDMPHR reception 3
—	Received value (RATE1)

OFDM PHRRX2	OFDMPHR reception 2
—	Received value (RATE2)

#### 4.2.144 OFDMPHR reception register 1 (BBOFDMPHRRX1)

This register holds the values of bits 17 to 21 of the PHY header data when an OFDM frame is received. The timing of the storage in this register is the same as the timing when the frame length value is stored. The values corresponding to the save bank specified by the receive data save bank select bit is read from this register. The value of this register following a reset is 00H.

**Figure 4-180 Format of OFDMPHR Reception Register 1 (BBOFDMPHRRX1)**

Address: 0177H After reset: 00H R

Symbol	7	6	5	4	3	2	1	0
BBOFDMPHRRX1	0	0	0	OFDM PHRRX21	OFDM PHRRX20	OFDM PHRRX19	OFDM PHRRX18	OFDM PHRRX17

OFDM PHRRX21	OFDMPHR reception 21
—	Received value (Reserved)

OFDM PHRRX20	OFDMPHR reception 20
—	Received value (SCBR0)

OFDM PHRRX19	OFDMPHR reception 19
—	Received value (SCBR1)

OFDM PHRRX18	OFDMPHR reception 18
—	Received value (Reserved)

OFDM PHRRX17	OFDMPHR reception 17
—	Received value (Reserved)

### 4.2.145 OFDMPHR reception register 2 (BBOFDMPHRRX2)

This register holds the values of bits 22 to 29 of the PHY header data when an OFDM frame is received. The timing of the storage in this register is the same as the timing when the frame length value is stored. The values corresponding to the save bank specified by the receive data save bank select bit is read from this register. The value of this register following a reset is 00H.

Figure 4-181 Format of OFDMPHR Reception Register 2 (BBOFDMPHRRX2) (1/2)

Address: 0178H After reset: 00H R

Symbol	7	6	5	4	3	2	1	0
BBOFDMPHRRX2	OFDM PHRRX29	OFDM PHRRX28	OFDM PHRRX27	OFDM PHRRX26	OFDM PHRRX25	OFDM PHRRX24	OFDM PHRRX23	OFDM PHRRX22

OFDM PHRRX29	OFDMPHR reception 29
—	Received value HCS0

OFDM PHRRX28	OFDMPHR reception 28
—	Received value HCS1

OFDM PHRRX27	OFDMPHR reception 27
—	Received value HCS2

OFDM PHRRX26	OFDMPHR reception 26
—	Received value HCS3

OFDM PHRRX25	OFDMPHR reception 25
—	Received value HCS4

OFDM PHRRX24	OFDMPHR reception 24
—	Received value HCS5

Figure 4-182 Format of OFDMPHR Reception Register 2 (BBOFDMPHRRX2) (2/2)

OFDM PHRRX23	OFDMPHR reception 23
—	Received value HCS6

OFDM PHRRX22	OFDMPHR reception 22
—	Received value HCS7

#### 4.2.146 OFDMCCA level threshold setting register (BBOFDMCCA VTH)

This register is used to set the threshold level for CCA in OFDM modulation. The frequency channel is judged to be busy when the CCA value is equal to or greater than the setting in this register. This device compares the receive level with the threshold in 10 bits; bits 9 to 0 of this register are used and bit 9 is the sign bit. Specify a value in 2's complement representation. The unit of setting is dBm. For example, 33DH indicates -97.5 dBm. The value of this register following a reset is 0200H.

Figure 4-183 Format of OFDMCCA Level Threshold Setting Register (BBOFDMCCA VTH)

Address: 017BH, 017AH After reset: 0200H R/W

Symbol	15	14	13	12	11	10	9	8
BBOFDMCCA VTH (017BH)	0	0	0	0	0	0	OFDMCCA VTH9	OFDMCCA VTH8
(017AH)	7	6	5	4	3	2	1	0
	OFDMCCA VTH7	OFDMCCA VTH6	OFDMCCA VTH5	OFDMCCA VTH4	OFDMCCA VTH3	OFDMCCA VTH2	OFDMCCA VTH1	OFDMCCA VTH0
	OFDMCCA VTH9 to OFDMCCA VTH0		OFDMCCA threshold					
	—		Threshold level for CCA in OFDM modulation					

**Caution** When writing to this register, set bits 15 to 10 to the value 0.

### 4.2.147 OFDM reception level threshold setting register (BBOFDMLVLVTH)

This register is used to set the threshold value for the receive level filter function in OFDM modulation. Reception is done for the level higher than the specified value. This device compares the receive level with the threshold in 10 bits; bits 9 to 0 of this register are used and bit 9 is the sign bit. Specify a value in 2's complement representation. The unit of setting is dBm. For example, 33DH indicates -97.5 dBm. The value of this register following a reset is 0200H.

**Figure 4-184 Format of OFDM Reception Level Threshold Setting Register (BBOFDMLVLVTH)**

Address: 017DH, 017CH After reset: 0200H R/W

Symbol	15	14	13	12	11	10	9	8
BBOFDMLVLVTH (017DH)	0	0	0	0	0	0	OFDMLVL VTHT9	OFDMLVL VTHT8
	7	6	5	4	3	2	1	0
(017CH)	OFDMLVL VTHT7	OFDMLVL VTHT6	OFDMLVL VTHT5	OFDMLVL VTHT4	OFDMLVL VTHT3	OFDMLVL VTHT2	OFDMLVL VTHT1	OFDMLVL VTHT0
	OFDMLVLVTHT9 to OFDMLVLVTHT0		OFDM receive level threshold					
	—		Threshold value for the receive level filter function in OFDM modulation					

**Caution** When writing to this register, set bits 15 to 10 to the value 0.



### 4.2.148 Port direction register 0 (GPIODIR0)

This register is used to set the I/O direction of the individual ports of GPIO0 to GPIO7. The value of this register following a reset is 00H.

Figure 4-185 Format of Port Direction Register 0 (GPIODIR0)

Address: 0190H After reset: 00H R/W

Symbol	7	6	5	4	3	2	1	0
GPIODIR0	GPIO7DIR	GPIO6DIR	GPIO5DIR	GPIO4DIR	GPIO3DIR	GPIO2DIR	GPIO1DIR	GPIO0DIR

GPIO7DIR	GPIO7 direction
0	Input port
1	Output port

GPIO6DIR	GPIO6 direction
0	Input port
1	Output port

GPIO5DIR	GPIO5 direction
0	Input port
1	Output port

GPIO4DIR	GPIO4 direction
0	Input port
1	Output port

GPIO3DIR	GPIO3 direction
0	Input port
1	Output port

GPIO2DIR	GPIO2 direction
0	Input port
1	Output port

GPIO1DIR	GPIO1 direction
0	Input port
1	Output port

GPIO0DIR	GPIO0 direction
0	Input port
1	Output port

### 4.2.149 Port direction register 1 (GPIODIR1)

This register is used to set the I/O direction of the individual ports of GPIO8 to GPIO12. The value of this register following a reset is 00H.

**Figure 4-186 Format of Port Direction Register 1 (GPIODIR1)**

Address: 0191H After reset: 00H R/W

Symbol	7	6	5	4	3	2	1	0
GPIODIR1	0	0	0	GPIO12DIR	GPIO11DIR	GPIO10DIR	GPIO9DIR	GPIO8DIR

GPIO12DIR	GPIO12 direction
0	Input port
1	Output port

GPIO11DIR	GPIO11 direction
0	Input port
1	Output port

GPIO10DIR	GPIO10 direction
0	Input port
1	Output port

GPIO9DIR	GPIO9 direction
0	Input port
1	Output port

GPIO8DIR	GPIO8 direction
0	Input port
1	Output port

**Caution** When writing to this register, set bits 7 to 5 to the value 0.

### 4.2.150 Port data register 0 (GPIODATA0)

This register is used to set the values to be output from the individual ports of GPIO0 to GPIO7 when they are set to output. When a GPIO port is set to input, the pin state (high or low) can be read from this register. The value of this register following a reset is 00H.

**Figure 4-187 Format of Port Data Register 0 (GPIODATA0) (1/2)**

Address: 0192H After reset: 00H (when the port is set to output) R/W

Symbol	7	6	5	4	3	2	1	0
GPIODATA	GPIO7DATA	GPIO6DATA	GPIO5DATA	GPIO4DATA	GPIO3DATA	GPIO2DATA	GPIO1DATA	GPIO0DATA
0								

GPIO7DATA	GPIO7 data
—	When the respective port pin is set to input, this bit indicates the value of the port pin. When the respective port pin is set to output, this bit sets the value to be output from the port pin. Set 0 or 1 to respectively output 0 or 1.

GPIO6DATA	GPIO6 data
—	When the respective port pin is set to input, this bit indicates the value of the port pin. When the respective port pin is set to output, this bit sets the value to be output from the port pin. Set 0 or 1 to respectively output 0 or 1.

GPIO5DATA	GPIO5 data
—	When the respective port pin is set to input, this bit indicates the value of the port pin. When the respective port pin is set to output, this bit sets the value to be output from the port pin. Set 0 or 1 to respectively output 0 or 1.

GPIO4DATA	GPIO4 data
—	When the respective port pin is set to input, this bit indicates the value of the port pin. When the respective port pin is set to output, this bit sets the value to be output from the port pin. Set 0 or 1 to respectively output 0 or 1.

GPIO3DATA	GPIO3 data
—	When the respective port pin is set to input, this bit indicates the value of the port pin. When the respective port pin is set to output, this bit sets the value to be output from the port pin. Set 0 or 1 to respectively output 0 or 1.

Figure 4-188 Format of Port Data Register 0 (GPIODATA0) (2/2)

GPIO2DATA	GPIO2 data
—	When the respective port pin is set to input, this bit indicates the value of the port pin. When the respective port pin is set to output, this bit sets the value to be output from the port pin. Set 0 or 1 to respectively output 0 or 1.
GPIO1DATA	GPIO1 data
—	When the respective port pin is set to input, this bit indicates the value of the port pin. When the respective port pin is set to output, this bit sets the value to be output from the port pin. Set 0 or 1 to respectively output 0 or 1.
GPIO0DATA	GPIO0 data
—	When the respective port pin is set to input, this bit indicates the value of the port pin. When the respective port pin is set to output, this bit sets the value to be output from the port pin. Set 0 or 1 to respectively output 0 or 1.

### 4.2.151 Port data register 1 (GPIODATA1)

This register is used to set the values to be output from the individual ports of GPIO8 to GPIO12 when they are set to output. When a GPIO port is set to input, the pin state (high or low) can be read from this register. The value of this register following a reset is 00H.

**Figure 4-189 Format of Port Data Register 1 (GPIODATA1)**

Address: 0193H After reset: 00H (when the port is set to output) R/W

Symbol	7	6	5	4	3	2	1	0
GPIODATA 1	0	0	0	GPIO12 DATA	GPIO11 DATA	GPIO10 DATA	GPIO9 DATA	GPIO8 DATA

GPIO12 DATA	GPIO12 data
—	When the respective port pin is set to input, this bit indicates the value of the port pin. When the respective port pin is set to output, this bit sets the value to be output from the port pin. Set 0 or 1 to respectively output 0 or 1.

GPIO11 DATA	GPIO11 data
—	When the respective port pin is set to input, this bit indicates the value of the port pin. When the respective port pin is set to output, this bit sets the value to be output from the port pin. Set 0 or 1 to respectively output 0 or 1.

GPIO10 DATA	GPIO10 data
—	When the respective port pin is set to input, this bit indicates the value of the port pin. When the respective port pin is set to output, this bit sets the value to be output from the port pin. Set 0 or 1 to respectively output 0 or 1.

GPIO9 DATA	GPIO9 data
—	When the respective port pin is set to input, this bit indicates the value of the port pin. When the respective port pin is set to output, this bit sets the value to be output from the port pin. Set 0 or 1 to respectively output 0 or 1.

GPIO8 DATA	GPIO8 data
—	When the respective port pin is set to input, this bit indicates the value of the port pin. When the respective port pin is set to output, this bit sets the value to be output from the port pin. Set 0 or 1 to respectively output 0 or 1.

**Caution** When writing to this register, set bits 7 to 5 to the value 0.

### 4.2.152 Port output driving capability switching register 0 (GPIODRV0)

This register is used to switch the output driving capability of the individual ports of GPIO0 to GPIO7 when they are set to output. The value of this register following a reset is 00H.

**Figure 4-190 Format of Port Output Driving Capability Switching Register 0 (GPIODRV0)**

Address: 0194H After reset: 00H R/W

Symbol	7	6	5	4	3	2	1	0
GPIODRV0	GPIO7DRV	GPIO6DRV	GPIO5DRV	GPIO4DRV	GPIO3DRV	GPIO2DRV	GPIO1DRV	GPIO0DRV

GPIO7DRV	GPIO7 driving capability
0	Low driving capability
1	High driving capability

GPIO6DRV	GPIO6 driving capability
0	Low driving capability
1	High driving capability

GPIO5DRV	GPIO5 driving capability
0	Low driving capability
1	High driving capability

GPIO4DRV	GPIO4 driving capability
0	Low driving capability
1	High driving capability

GPIO3DRV	GPIO3 driving capability
0	Low driving capability
1	High driving capability

GPIO2DRV	GPIO2 driving capability
0	Low driving capability
1	High driving capability

GPIO1DRV	GPIO1 driving capability
0	Low driving capability
1	High driving capability

GPIO0DRV	GPIO0 driving capability
0	Low driving capability
1	High driving capability

### 4.2.153 Port output driving capability switching register 1 (GPIODRV1)

This register is used to switch the output driving capability of the individual ports of GPIO8 to GPIO12 and SOUT when they are set to output. The value of this register following a reset is 00H.

**Figure 4-191 Format of Port Output Driving Capability Switching Register 1 (GPIODRV1)**

Address: 0195H After reset: 00H R/W

Symbol	7	6	5	4	3	2	1	0
GPIODRV1	0	0	SOUTDRV	GPIO12DRV	GPIO11DRV	GPIO10DRV	GPIO9DRV	GPIO8DRV

SOUTDRV	SOUT driving capability
0	Low driving capability
1	High driving capability

GPIO12DRV	GPIO12 driving capability
0	Low driving capability
1	High driving capability

GPIO11DRV	GPIO11 driving capability
0	Low driving capability
1	High driving capability

GPIO10DRV	GPIO10 driving capability
0	Low driving capability
1	High driving capability

GPIO9DRV	GPIO9 driving capability
0	Low driving capability
1	High driving capability

GPIO8DRV	GPIO8 driving capability
0	Low driving capability
1	High driving capability

**Caution** When writing to this register, set bits 7 and 6 to the value 0.

#### 4.2.154 Pull-up/pull-down selection register 0 (PULLSEL0)

This register is used to enable or disable the pull-up and pull-down of the individual ports of GPIO0 to GPIO3. When the pull-up and pull-down of a port is enabled, the selection of pull-up or pull-down takes effect. Note that the pull-up or pull-down is disabled when a port is set to output. The value of this register following a reset is FFH.

Figure 4-192 Format of Pull-Up/Pull-Down Selection Register 0 (PULLSEL0) (1/2)

Address: 0198H After reset: FFH R/W

Symbol	7	6	5	4	3	2	1	0
PULLSEL0	PULL3SEL	PULL3EN	PULL2SEL	PULL2EN	PULL1SEL	PULL1EN	PULL0SEL	PULL0EN

PULL3SEL	PULL3 selection
0	GPIO3 = Pulled down
1	GPIO3 = Pulled up

PULL3EN	PULL3 enable
0	GPIO3 = Pull-up and pull-down are disabled.
1	GPIO3 = Pull-up and pull-down are enabled.

PULL2SEL	PULL2 selection
0	GPIO2 = Pulled down
1	GPIO2 = Pulled up

PULL2EN	PULL2 enable
0	GPIO2 = Pull-up and pull-down are disabled.
1	GPIO2 = Pull-up and pull-down are enabled.

PULL1SEL	PULL1 selection
0	GPIO1 = Pulled down
1	GPIO1 = Pulled up

PULL1EN	PULL1 enable
0	GPIO1 = Pull-up and pull-down are disabled.
1	GPIO1 = Pull-up and pull-down are enabled.



Figure 4-193 Format of Pull-Up/Pull-Down Selection Register 0 (PULLSEL0) (2/2)

PULL0SEL	PULL0 selection
0	GPIO0 = Pulled down
1	GPIO0 = Pulled up

PULL0EN	PULL0 enable
0	GPIO0 = Pull-up and pull-down are disabled.
1	GPIO0 = Pull-up and pull-down are enabled.

### 4.2.155 Pull-up/pull-down selection register 1 (PULLSEL1)

This register is used to enable or disable the pull-up and pull-down of the individual ports of GPIO4 to GPIO7. When the pull-up and pull-down of a port is enabled, the selection of pull-up or pull-down takes effect. Note that the pull-up or pull-down is disabled when a port is set to output. The value of this register following a reset is FFH.

**Figure 4-194 Format of Pull-Up/Pull-Down Selection Register 1 (PULLSEL1) (1/2)**

Address: 0199H After reset: FFH R/W

Symbol	7	6	5	4	3	2	1	0
PULLSEL1	PULL7SEL	PULL7EN	PULL6SEL	PULL6EN	PULL5SEL	PULL5EN	PULL4SEL	PULL4EN

PULL7SEL	PULL7 selection
0	GPIO7 = Pulled down
1	GPIO7 = Pulled up

PULL7EN	PULL7 enable
0	GPIO7 = Pull-up and pull-down are disabled.
1	GPIO7 = Pull-up and pull-down are enabled.

PULL6SEL	PULL6 selection
0	GPIO6 = Pulled down
1	GPIO6 = Pulled up

PULL6EN	PULL6 enable
0	GPIO6 = Pull-up and pull-down are disabled.
1	GPIO6 = Pull-up and pull-down are enabled.

PULL5SEL	PULL5 selection
0	GPIO5 = Pulled down
1	GPIO5 = Pulled up

PULL5EN	PULL5 enable
0	GPIO5 = Pull-up and pull-down are disabled.
1	GPIO5 = Pull-up and pull-down are enabled.

Figure 4-195 Format of Pull-Up/Pull-Down Selection Register 1 (PULLSEL1) (2/2)

PULL4SEL	PULL4 selection
0	GPIO4 = Pulled down
1	GPIO4 = Pulled up

PULL4EN	PULL4 enable
0	GPIO4 = Pull-up and pull-down are disabled.
1	GPIO4 = Pull-up and pull-down are enabled.

### 4.2.156 Pull-up/pull-down selection register 2 (PULLSEL2)

This register is used to enable or disable the pull-up and pull-down of the individual ports of GPIO8 to GPIO11. When the pull-up and pull-down of a port is enabled, the selection of pull-up or pull-down takes effect. Note that the pull-up or pull-down is disabled when a port is set to output. The value of this register following a reset is FFH.

**Figure 4-196 Format of Pull-Up/Pull-Down Selection Register 2 (PULLSEL2) (1/2)**

Address: 019AH After reset: FFH R/W

Symbol	7	6	5	4	3	2	1	0
PULLSEL2	PULL11SEL	PULL11EN	PULL10SEL	PULL10EN	PULL9SEL	PULL9EN	PULL8SEL	PULL8EN

PULL11SEL	PULL11 selection
0	GPIO11 = Pulled down
1	GPIO11 = Pulled up

PULL11EN	PULL11 enable
0	GPIO11 = Pull-up and pull-down are disabled.
1	GPIO11 = Pull-up and pull-down are enabled.

PULL10SEL	PULL10 selection
0	GPIO10 = Pulled down
1	GPIO10 = Pulled up

PULL10EN	PULL10 enable
0	GPIO10 = Pull-up and pull-down are disabled.
1	GPIO10 = Pull-up and pull-down are enabled.

PULL9SEL	PULL9 selection
0	GPIO9 = Pulled down
1	GPIO9 = Pulled up

PULL9EN	PULL9 enable
0	GPIO9 = Pull-up and pull-down are disabled.
1	GPIO9 = Pull-up and pull-down are enabled.

Figure 4-197 Format of Pull-Up/Pull-Down Selection Register 2 (PULLSEL2) (2/2)

PULL8SEL	PULL8 selection
0	GPIO8 = Pulled down
1	GPIO8 = Pulled up

PULL8EN	PULL8 enable
0	GPIO8 = Pull-up and pull-down are disabled.
1	GPIO8 = Pull-up and pull-down are enabled.

### 4.2.157 Pull-up/pull-down selection register 3 (PULLSEL3)

This register is used to enable or disable the pull-up and pull-down of the individual ports of GPIO12, SEN, SIN, and SCLK. When the pull-up and pull-down of a port is enabled, the selection of pull-up or pull-down takes effect. Note that the pull-up or pull-down is disabled when a port is set to output. The value of this register following a reset is FFH.

Figure 4-198 Format of Pull-Up/Pull-Down Selection Register 3 (PULLSEL3) (1/2)

Address: 019BH After reset: FFH R/W

Symbol	7	6	5	4	3	2	1	0
PULLSEL3	PULLSCLK SEL	PULLSCLK EN	PULLSIN SEL	PULLSIN EN	PULLSEN SEL	PULLSEN EN	PULL12 SEL	PULL12 EN

PULLSCLK SEL	PULLSCLK selection
0	SCLK = Pulled down
1	SCLK = Pulled up

PULLSCLK EN	PULLSCLK enable
0	SCLK = Pull-up and pull-down are disabled.
1	SCLK = Pull-up and pull-down are enabled.

PULLSIN SEL	PULLSIN selection
0	SIN = Pulled down
1	SIN = Pulled up

PULLSIN EN	PULLSIN enable
0	SIN = Pull-up and pull-down are disabled.
1	SIN = Pull-up and pull-down are enabled.

PULLSEN SEL	PULLSEN selection
0	SEN = Pulled down
1	SEN = Pulled up

Figure 4-199 Format of Pull-Up/Pull-Down Selection Register 3 (PULLSEL3) (2/2)

PULLSEN EN	PULLSEN enable
0	SEN = Pull-up and pull-down are disabled.
1	SEN = Pull-up and pull-down are enabled.

PULL12 SEL	PULL12 selection
0	GPIO12 = Pulled down
1	GPIO12 = Pulled up

PULL12 EN	PULL12 enable
0	GPIO12 = Pull-up and pull-down are disabled.
1	GPIO12 = Pull-up and pull-down are enabled.

### 4.2.158 GPIO function selection register 0 (BBGPIOFUNCSEL0)

The pin functions of the port pins GPIO0 and GPIO1 can be selected by setting the GPIO0 and GPIO1 function selection bits, respectively. The value of this register following a reset is 00H.

**Figure 4-200 Format of GPIO Function Selection Register 0 (BBGPIOFUNCSEL0)**

Address: 01A0H After reset: 00H R/W

Symbol	7	6	5	4	3	2	1	0
BBGPIO FUNCSEL0	GPIO1SEL3	GPIO1SEL2	GPIO1SEL1	GPIO1SEL0	GPIO0SEL3	GPIO0SEL2	GPIO0SEL1	GPIO0SEL0

GPIO1SEL3	GPIO1SEL2	GPIO1SEL1	GPIO1SEL0	GPIO1 function selection
0	0	0	0	GPIO
0	0	0	1	INTOUT0
0	0	1	0	Reserved
0	0	1	1	Reserved
0	1	0	0	CTX
0	1	0	1	CPS
0	1	1	0	CSD
0	1	1	1	Reserved
1	0	0	0	Reserved
1	0	0	1	Reserved
1	0	1	0	Reserved
Other than above				Setting prohibited

GPIO0SEL3	GPIO0SEL2	GPIO0SEL1	GPIO0SEL0	GPIO0 function selection
0	0	0	0	GPIO
0	0	0	1	INTOUT0
0	0	1	0	Reserved
0	0	1	1	Reserved
0	1	0	0	CTX
0	1	0	1	CPS
0	1	1	0	CSD
0	1	1	1	Reserved
1	0	0	0	Reserved
1	0	0	1	Reserved
1	0	1	0	Reserved
Other than above				Setting prohibited



### 4.2.159 GPIO function selection register 1 (BBGPIOFUNCSEL1)

The pin functions of the port pins GPIO2 and GPIO3 can be selected by setting the GPIO2 and GPIO3 function selection bits, respectively. The value of this register following a reset is 00H.

Figure 4-201 Format of GPIO Function Selection Register 1 (BBGPIOFUNCSEL1)

Address: 01A1H After reset: 00H R/W

Symbol	7	6	5	4	3	2	1	0
BBGPIO FUNCSEL1	GPIO3SEL3	GPIO3SEL2	GPIO3SEL1	GPIO3SEL0	GPIO2SEL3	GPIO2SEL2	GPIO2SEL1	GPIO2SEL0

GPIO3SEL3	GPIO3SEL2	GPIO3SEL1	GPIO3SEL0	GPIO3 function selection
0	0	0	0	GPIO
0	0	0	1	INTOUT0
0	0	1	0	Reserved
0	0	1	1	Reserved
0	1	0	0	CTX
0	1	0	1	CPS
0	1	1	0	CSD
0	1	1	1	Reserved
1	0	0	0	Reserved
1	0	0	1	Reserved
1	0	1	0	Reserved
Other than above				Setting prohibited

GPIO2SEL3	GPIO2SEL2	GPIO2SEL1	GPIO2SEL0	GPIO2 function selection
0	0	0	0	GPIO
0	0	0	1	INTOUT0
0	0	1	0	Reserved
0	0	1	1	Reserved
0	1	0	0	CTX
0	1	0	1	CPS
0	1	1	0	CSD
0	1	1	1	Reserved
1	0	0	0	Reserved
1	0	0	1	Reserved
1	0	1	0	Reserved
Other than above				Setting prohibited

### 4.2.160 GPIO function selection register 2 (BBGPIOFUNCSEL2)

The pin functions of the port pins GPIO4 and GPIO5 can be selected by setting the GPIO4 and GPIO5 function selection bits, respectively. The value of this register following a reset is 00H.

**Figure 4-202 Format of GPIO Function Selection Register 2 (BBGPIOFUNCSEL2)**

Address: 01A2H After reset: 00H R/W

Symbol	7	6	5	4	3	2	1	0
BBGPIO FUNCSEL2	GPIO5SEL3	GPIO5SEL2	GPIO5SEL1	GPIO5SEL0	GPIO4SEL3	GPIO4SEL2	GPIO4SEL1	GPIO4SEL0

GPIO5SEL3	GPIO5SEL2	GPIO5SEL1	GPIO5SEL0	GPIO5 function selection
0	0	0	0	GPIO
0	0	0	1	INTOUT0
0	0	1	0	Reserved
0	0	1	1	Reserved
0	1	0	0	CTX
0	1	0	1	CPS
0	1	1	0	CSD
0	1	1	1	Reserved
1	0	0	0	Reserved
1	0	0	1	Reserved
1	0	1	0	Reserved
Other than above				Setting prohibited

GPIO4SEL3	GPIO4SEL2	GPIO4SEL1	GPIO4SEL0	GPIO4 function selection
0	0	0	0	GPIO
0	0	0	1	INTOUT0
0	0	1	0	Reserved
0	0	1	1	Reserved
0	1	0	0	CTX
0	1	0	1	CPS
0	1	1	0	CSD
0	1	1	1	Reserved
1	0	0	0	Reserved
1	0	0	1	Reserved
1	0	1	0	Reserved
Other than above				Setting prohibited

### 4.2.161 GPIO function selection register 3 (BBGPIOFUNCSEL3)

The pin functions of the port pins GPIO6 and GPIO7 can be selected by setting the GPIO6 and GPIO7 function selection bits, respectively. The value of this register following a reset is 00H.

**Figure 4-203 Format of GPIO Function Selection Register 3 (BBGPIOFUNCSEL3)**

Address: 01A3H After reset: 00H R/W

Symbol	7	6	5	4	3	2	1	0
BBGPIO FUNCSEL3	GPIO7SEL3	GPIO7SEL2	GPIO7SEL1	GPIO7SEL0	GPIO6SEL3	GPIO6SEL2	GPIO6SEL1	GPIO6SEL0

GPIO7SEL3	GPIO7SEL2	GPIO7SEL1	GPIO7SEL0	GPIO7 function selection
0	0	0	0	GPIO
0	0	0	1	INTOUT0
0	0	1	0	Reserved
0	0	1	1	Reserved
0	1	0	0	CTX
0	1	0	1	CPS
0	1	1	0	CSD
0	1	1	1	Reserved
1	0	0	0	Reserved
1	0	0	1	Reserved
1	0	1	0	Reserved
Other than above				Setting prohibited

GPIO6SEL3	GPIO6SEL2	GPIO6SEL1	GPIO6SEL0	GPIO6 function selection
0	0	0	0	GPIO
0	0	0	1	INTOUT0
0	0	1	0	Reserved
0	0	1	1	Reserved
0	1	0	0	CTX
0	1	0	1	CPS
0	1	1	0	CSD
0	1	1	1	Reserved
1	0	0	0	Reserved
1	0	0	1	Reserved
1	0	1	0	Reserved
Other than above				Setting prohibited

### 4.2.162 GPIO function selection register 4 (BBGPIOFUNCSEL4)

The pin functions of the port pins GPIO8 and GPIO9 can be selected by setting the GPIO8 and GPIO9 function selection bits, respectively. The value of this register following a reset is 00H.

**Figure 4-204 Format of GPIO Function Selection Register 4 (BBGPIOFUNCSEL4)**

Address: 01A4H After reset: 00H R/W

Symbol	7	6	5	4	3	2	1	0
BBGPIO FUNCSEL4	GPIO9SEL3	GPIO9SEL2	GPIO9SEL1	GPIO9SEL0	GPIO8SEL3	GPIO8SEL2	GPIO8SEL1	GPIO8SEL0

GPIO9SEL3	GPIO9SEL2	GPIO9SEL1	GPIO9SEL0	GPIO9 function selection
0	0	0	0	GPIO
0	0	0	1	INTOUT0
0	0	1	0	Reserved
0	0	1	1	Reserved
0	1	0	0	CTX
0	1	0	1	CPS
0	1	1	0	CSD
0	1	1	1	Reserved
1	0	0	0	Reserved
1	0	0	1	Reserved
1	0	1	0	Reserved
Other than above				Setting prohibited

GPIO8SEL3	GPIO8SEL2	GPIO8SEL1	GPIO8SEL0	GPIO8 function selection
0	0	0	0	GPIO
0	0	0	1	INTOUT0
0	0	1	0	Reserved
0	0	1	1	Reserved
0	1	0	0	CTX
0	1	0	1	CPS
0	1	1	0	CSD
0	1	1	1	Reserved
1	0	0	0	Reserved
1	0	0	1	Reserved
1	0	1	0	Reserved
Other than above				Setting prohibited

### 4.2.163 GPIO function selection register 5 (BBGPIOFUNCSEL5)

The pin functions of the port pins GPIO10 and GPIO11 can be selected by setting the GPIO10 and GPIO11 function selection bits, respectively. The value of this register following a reset is 00H.

**Figure 4-205 Format of GPIO Function Selection Register 5 (BBGPIOFUNCSEL5)**

Address: 01A5H After reset: 00H R/W

Symbol	7	6	5	4	3	2	1	0
BBGPIO FUNCSEL5	GPIO11SEL 3	GPIO11SEL 2	GPIO11SEL 1	GPIO11SEL 0	GPIO10SEL 3	GPIO10SEL 2	GPIO10SEL 1	GPIO10SEL 0

GPIO11SEL 3	GPIO11SEL 2	GPIO11SEL 1	GPIO11SEL 0	GPIO11 function selection
0	0	0	0	GPIO
0	0	0	1	INTOUT0
0	0	1	0	Reserved
0	0	1	1	Reserved
0	1	0	0	CTX
0	1	0	1	CPS
0	1	1	0	CSD
0	1	1	1	Reserved
1	0	0	0	Reserved
1	0	0	1	Reserved
1	0	1	0	Reserved
Other than above				Setting prohibited

GPIO10SEL 3	GPIO10SEL 2	GPIO10SEL 1	GPIO10SEL 0	GPIO10 function selection
0	0	0	0	GPIO
0	0	0	1	INTOUT0
0	0	1	0	Reserved
0	0	1	1	Reserved
0	1	0	0	CTX
0	1	0	1	CPS
0	1	1	0	CSD
0	1	1	1	Reserved
1	0	0	0	Reserved
1	0	0	1	Reserved
1	0	1	0	Reserved
Other than above				Setting prohibited

#### 4.2.164 GPIO function selection register 6 (BBGPIOFUNCSEL6)

The pin function of the port pin GPIO12 can be selected by setting the GPIO12 function selection bit. The value of this register following a reset is 00H.

Figure 4-206 Format of GPIO Function Selection Register 6 (BBGPIOFUNCSEL6)

Address: 01A6H After reset: 00H R/W

Symbol	7	6	5	4	3	2	1	0
BBGPIO FUNCSEL6	0	0	0	0	GPIO12SEL 3	GPIO12SEL 2	GPIO12SEL 1	GPIO12SEL 0

GPIO12SEL 3	GPIO12SEL 2	GPIO12SEL 1	GPIO12SEL 0	GPIO12 function selection
0	0	0	0	GPIO
0	0	0	1	INTOUT0
0	0	1	0	Reserved
0	0	1	1	Reserved
0	1	0	0	CTX
0	1	0	1	CPS
0	1	1	0	CSD
0	1	1	1	Reserved
1	0	0	0	Reserved
1	0	0	1	Reserved
1	0	1	0	Reserved
Other than above				Setting prohibited

**Caution** When writing to this register, set bits 7 to 4 to the value 0.

### 4.2.165 RX-state OSC setting register (BBRXOSC)

The RXDDC clock division ratio control bit is used to select the division ratio of the clock for the DDC for reception. The value of this register following a reset is 00H. See the latest application note which specifies the recommended register settings for use with this product.

Figure 4-207 Format of RX-State OSC Setting Register (BBRXOSC)

Address: 01C8H After reset: 00H R/W

Symbol	7	6	5	4	3	2	1	0
BBRXOSC	0	0	0	0	0	RXOSCBFD DCDIVSEL2	RXOSCBFD DCDIVSEL1	RXOSCBFD DCDIVSEL0

RXOSCBFD DCDIVSEL2	RXOSCBFD DCDIVSEL1	RXOSCBFD DCDIVSEL0	RXDDC clock division ratio control
0	0	0	Division ratio is 12.
0	0	1	Division ratio is 13.
0	1	0	Division ratio is 14.
0	1	1	Division ratio is 11.
1	0	0	Division ratio is 10.
1	0	1	Division ratio is 9.
1	1	0	Setting prohibited
1	1	1	Setting prohibited

**Caution** When writing to this register, set bits 7 to 3 to the value 0.

### 4.2.166 NEWMODE transmission control register (BBNMTXCON)

The automatic NEWMODE transmission enable 0 to 2 bits are used to automatically transmit a NEWMODE frame. Setting all bits to 1 transmits a NEWMODE frame after the transmission of a mode switch frame. Be sure to set all bits to the same value. The method of automatic NEWMODE frame transmission can be selected by the NEWMODE transmission method selection bit.

0: FSK transmission

The settings in the NEWMODE transmission frequency setting register and NEWMODE transmission FSK control registers 0 and 1 are used for transmission.

1: OFDM transmission

The settings in the NEWMODE transmission frequency setting register, OFDM control register, and OFDMPHR transmission registers 0 and 1 are used for transmission.

The NEWMODE transmission sequence switch 0 and 1 bits select the operation sequence. Be sure to set both bits to the same value. The NEWMODE transmission enable bit enables or disables the transmission of a NEWMODE frame. While this bit is 0, transmission is not enabled even when the timing of enabling transmission comes in the MODEM block. The NEWMODE transmission completion interrupt selection bit is used to set the number of generation times of frame transmission completion interrupts in automatic NEWMODE transmission.

- When the setting of the NEWMODE transmission completion interrupt selection bit is 0:  
Frame transmission completion interrupts are generated twice, that is, upon completions of the transmission of the mode switch frame and of the transmission of a NEWMODE frame.
- When the setting of the NEWMODE transmission completion interrupt selection bit is 1:  
A frame transmission completion interrupt is only generated once, that is, upon completion of the transmission of a NEWMODE frame. The interrupt is not generated upon completion of the transmission of a mode switch frame.

The value of this register following a reset is 80H.

**Table 4-3 Settings of NEWMODE Transmit Registers**

Register	Address	Bit	Normal Sequence	Shortest Sequence	Remark
Address 057H		b7 to b0	65H	15H	For FSK and OFDM
Address 058H		b7 to b0	8DH	3DH	For FSK and OFDM
Automatic NEWMODE transmission enable 0 bit	01E8H	b0	1 (automatic transmission is enabled)		For FSK and OFDM
NEWMODE transmission method selection bit	01E8H	b1	0 (FSK) or 1 (OFDM)	0 (FSK) or 1 (OFDM)	For FSK and OFDM
Automatic NEWMODE transmission enable 1 bit	01E8H	b2	1 (automatic transmission is enabled)		For FSK and OFDM
Automatic NEWMODE transmission enable 2 bit	01E8H	b3	1 (automatic transmission is enabled)		For FSK and OFDM
NEWMODE transmission sequence switch 0 bit	01E8H	b4	0	1	For FSK and OFDM
NEWMODE transmission enable bit	01E8H	b5	1 (enabled)	1 (enabled)	For FSK and OFDM
NEWMODE transmission sequence switch 1 bit	01E8H	b6	0	1	For FSK and OFDM
NEWMODE transmission SX shift frequency setting bits	01EBH, 01EAH	b11 to b0	0 ( $\pm 0$ )	Value set for the SX shift frequency	For FSK and OFDM
NEWMODE transmission frequency setting bits	01EFH to 01ECH	b29 to b0	Frequency of NEWMODE frame transmission	Setting is ignored.	For FSK and OFDM
NEWMODE transmission FSK control registers 0 and 1	01F1H, 01F0H	—	Desired setting		For FSK
OFDM control register	0170H	—	Desired setting		For OFDM
OFDMPHR transmission registers 0 and 1	0173H, 0172H	—	Desired setting		For OFDM



Figure 4-208 Format of NEWMODE Transmission Control Register (BBNMTXCON)

Address: 01E8H After reset: 80H R/W

Symbol	7	6	5	4	3	2	1	0
BBNMTX	NMTX	NMTX	NMTX	NMTX	NMTX	NMTX	NMTX	NMTX
CON	INTSEL	SQC1	EN	SQC0	ON2	ON1	MODE	ON0

NMTX INTSEL	NEWMODE transmission completion interrupt selection
0	An interrupt is generated upon completion of the transmission of the mode switch frame.
1	No interrupt is generated upon completion of the transmission of the mode switch frame.

NMTX SQC1	NEWMODE transmission sequence switch 1
0	Normal sequence
1	Shortest sequence

NMTXEN	NEWMODE transmission enable
0	NEWMODE transmission is disabled.
1	NEWMODE transmission is enabled.

NMTXSQC0	NEWMODE transmission sequence switch 0
0	Normal sequence
1	Shortest sequence

NMTXON2	Automatic NEWMODE transmission enable 2
0	Automatic transmission is disabled.
1	Automatic transmission is enabled

NMTXON1	Automatic NEWMODE transmission enable 1
0	Automatic transmission is disabled.
1	Automatic transmission is enabled

NMTXMODE	NEWMODE transmission method selection
0	FSK transmission
1	OFDM transmission

NMTXON0	Automatic NEWMODE transmission enable 0
0	Automatic transmission is disabled.
1	Automatic transmission is enabled.

#### 4.2.167 NEWMODE Transmission SX shift frequency setting register (BBNMTXSXSFTFREQ)

The NEWMODE transmission SX shift frequency setting bits are used to set the amount of SX frequency shifting in NEWMODE transmission. The setting is possible in 1-kHz units (1H = 1 kHz).

000H: 0 kHz

001H: 1 kHz

002H: 2 kHz

:

0C8H: 200 kHz

:

7FFH: 2047 kHz

800H: 0 kHz

801H: -1 kHz

802H: -2 kHz

:

8C8H: -200 kHz

:

FFFH: -2047 kHz

This device uses this setting to shift the SX frequency when the NEWMODE transmission sequence switch 0 and 1 bits are set to 1. The device ignores this setting when the switch bits are 0. The value of this register following a reset is 0000H.

**Figure 4-209 Format of NEWMODE Transmission SX Shift Frequency Setting Register (BBNMTXSXSFTFREQ)**

Address: 01EBH, 01EAH After reset: 0000H R/W

Symbol	15	14	13	12	11	10	9	8
BBNMTXSXSFTFREQ (01EBH)	0	0	0	0	NMTXSX SFTFREQ11	NMTXSX SFTFREQ10	NMTXSX SFTFREQ9	NMTXSX SFTFREQ8
(01EAH)	7	6	5	4	3	2	1	0
	NMTXSX SFTFREQ7	NMTXSX SFTFREQ6	NMTXSX SFTFREQ5	NMTXSX SFTFREQ4	NMTXSX SFTFREQ3	NMTXSX SFTFREQ2	NMTXSX SFTFREQ1	NMTXSX SFTFREQ0
NMTXSXSFTFREQ11 to NMTXSXSFTFREQ0		NEWMODE transmission SX shift frequency setting						
—		These bits set the amount of SX frequency shifting.						

**Caution** When writing to this register, set bits 15 to 12 to the value 0.

### 4.2.168 NEWMODE transmission frequency setting register (BBNMTXFREQ)

This register is used to set the frequency of NEWMODE transmission after the transmission of a mode switch frame. This register consists of 30 bits. The frequency can be set in 1-Hz steps. The initial value is 36FC3BA0H, that is, 922.5 MHz. Set a value from 337055C0H (863 MHz) to 37502800H (928 MHz). All four bytes should be specified starting from the lowest-order address. The frequency of NEWMODE transmission is switched to the value specified in this register when the NEWMODE transmission sequence switch 0 and 1 bits are 0. When the switch bits are set to 1, this device ignores the setting in this register and uses the value specified in the frequency setting register. The value of this register following a reset is 36FC3BA0H.

Figure 4-210 Format of NEWMODE Transmission Frequency Setting Register (BBNMTXFREQ)

Address: 01EFH to 01ECH After reset: 36FC3BA0H R/W

Symbol	31	30	29	28	27	26	25	24
BBNMTXFREQ (01EFH)	0	0	NMTXFREQ	NMTXFREQ	NMTXFREQ	NMTXFREQ	NMTXFREQ	NMTXFREQ
			29	28	27	26	25	24
(01EEH)								
	NMTXFREQ	NMTXFREQ	NMTXFREQ	NMTXFREQ	NMTXFREQ	NMTXFREQ	NMTXFREQ	NMTXFREQ
(01EDH)								
	NMTXFREQ	NMTXFREQ	NMTXFREQ	NMTXFREQ	NMTXFREQ	NMTXFREQ	NMTXFREQ	NMTXFREQ
(01ECH)								
	NMTXFREQ	NMTXFREQ	NMTXFREQ	NMTXFREQ	NMTXFREQ	NMTXFREQ	NMTXFREQ	NMTXFREQ
NMTXFREQ29 to NMTXFREQ0			NEWMODE transmission frequency setting					
—			Frequency of NEWMODE transmission					

**Caution** When writing to this register, set bits 31 and 30 to the value 0.

### 4.2.169 NEWMODE transmission FSK control register 0 (BBNMTXFSKCON0)

The NEWMODE transmission FSK modulation index setting bit is used to specify the modulation index for FSK transmission. The rate of FSK data transmission can be selected by the NEWMODE transmission FSK data rate selection bits. The value of this register following a reset is 00H.

**Figure 4-211 Format of NEWMODE Transmission FSK Control Register 0 (BBNMTXFSKCON0)**

Address: 01F0H After reset: 00H R/W

Symbol	7	6	5	4	3	2	1	0
BBNMTX FSKCON0	0	0	0	NMTXFSK RATE3	NMTXFSK RATE2	NMTXFSK RATE1	NMTXFSK RATE0	NMTXFSK INDEX

NMTXFSK RATE3	NMTXFSK RATE2	NMTXFSK RATE1	NMTXFSK RATE0	NEWMODE transmission FSK data rate selection
0	0	0	0	50 kbps
0	0	0	1	100 kbps
0	0	1	0	150 kbps
0	0	1	1	200 kbps
0	1	0	0	10 kbps
0	1	0	1	20 kbps
0	1	1	0	Setting prohibited
0	1	1	1	Setting prohibited
1	0	0	0	9.6 kbps
1	0	0	1	19.2 kbps
1	0	1	0	38.4 kbps
1	0	1	1	115.2 kbps
1	1	0	0	Setting prohibited
1	1	0	1	Setting prohibited
1	1	1	0	Setting prohibited
1	1	1	1	Setting prohibited

NMTXFSK INDEX	NEWMODE transmission FSK modulation index setting
0	0.5
1	1.0

**Caution** When writing to this register, set bits 7 to 5 to the value 0.

### 4.2.170 NEWMODE transmission FSK control register 1 (BBNMTXFSKCON1)

The NEWMODE transmission FEC enable bit enables FEC for NEWMODE transmission. The NEWMODE transmission FSKFEC mode switch bit is used to switch the mode of FEC encoding for NEWMODE transmission. The NEWMODE transmission FSKCRC bit count switch bit selects the number of CRC calculation bits for NEWMODE transmission. The NEWMODE transmission FSKDW enable bit enables data whitening for NEWMODE transmission. The NEWMODE transmission FSKPHR transmission 1 and 2 bits are used to specify the values of bits 1 and 2 of the PHR for NEWMODE transmission, respectively. The NEWMODE transmission FSK interleaving enable bit enables interleaving for NEWMODE transmission. Set this bit to 1 when using the NRNSC encoder. When using the RSC encoder, interleaving can be enabled or disabled as desired. The value of this register following a reset is 0CH.

**Figure 4-212 Format of NEWMODE Transmission FSK Control Register 1 (BBNMTXFSKCON1) (1/2)**

Address: 01F1H After reset: 0CH R/W

Symbol	7	6	5	4	3	2	1	0
BBNMTX FSKCON1	NMTX MRFSKSFD	NMTXFSK INTLVEN	NMTXFSK PHRTX2	NMTXFSK PHRTX1	NMTXFSK DWEN	NMTXFSK CRCBIT	NMTXFSK FECMODE	NMFEC ENTX

NMTX MRFSKSFD	NEWMODE transmission MRFSKSFD selection
0	phyMRFSKSFD = 0
1	phyMRFSKSFD = 1

NMTXFSK INTLVEN	NEWMODE transmission FSK interleaving enable
0	Interleaving is disabled.
1	Interleaving is enabled.

NMTXFSK PHRTX2	NEWMODE transmission FSKPHR transmission 2
—	Value to be transmitted.

NMTXFSK PHRTX1	NEWMODE transmission FSKPHR transmission 1
—	Value to be transmitted.

Figure 4-213 Format of NEWMODE Transmission FSK Control Register 1 (BBNMTXFSKCON1) (2/2)

NMTXFSK DWEN	NEWMODE transmission FSKDW enable
0	Data whitening is disabled.
1	Data whitening is enabled.

NMTXFSK CRCBIT	NEWMODE transmission FSKCRC bit count switch
0	32-bit CRC
1	16-bit CRC

NMTXFSK FECMODE	NEWMODE transmission FSKFEC mode switch
0	NRNSC encoder
1	RSC encoder

NMFEC ENTX	NEWMODE transmission FEC enable
0	FEC is disabled.
1	FEC is enabled.

### 4.2.171 NEWMODE reception control register 0 (BBNMRXCON0)

The NEWMODE reception setting 0 bit is used to switch the reception settings to those in the registers for NEWMODE reception after the reception of a mode switch frame. After a mode switch frame is received while this bit is set to 1, the settings in the following registers for NEWMODE reception take effect when the next receive trigger is set.

Registers for NEWMODE reception:

NEWMODE reception control registers 0 and 1, NEWMODE reception frequency setting register, NEWMODE reception FSK control registers 0 and 1, and NEWMODE reception OFDM control register

Be sure to set the NEWMODE reception setting 1 bit to the same value as the NEWMODE reception setting 0 bit. The NEWMODE reception enable bit enables or disables the reception of a NEWMODE frame. While this bit is 0, reception is not enabled even when the timing of enabling reception comes in the MODEM block. The value of this register following a reset is 00H.

**Figure 4-214 Format of NEWMODE Reception Control Register 0 (BBNMRXCON0)**

Address: 01F2H After reset: 00H R/W

Symbol	7	6	5	4	3	2	1	0
BBNMRX CON0	0	0	0	0	0	NMRX EN	NMRX MODEON1	NMRX MODEON0

NMRXEN	NEWMODE reception enable
0	NEWMODE reception is disabled.
1	NEWMODE reception is enabled.

NMRX MODEON1	NEWMODE reception setting 1
0	NEWMODE reception is disabled.
1	NEWMODE reception is enabled.

NMRX MODEON0	NEWMODE reception setting 0
0	NEWMODE reception is disabled.
1	NEWMODE reception is enabled.

**Caution** When writing to this register, set bits 7 to 3 to the value 0.

### 4.2.172 NEWMODE reception control register 1 (BBNMRXCON1)

The NEWMODE reception setting switch bits are used to select the bank of the NEWMODE reception control register 2, NEWMODE reception frequency setting register, NEWMODE reception FSK control registers 0 and 1, and NEWMODE reception OFDM control register to be used for settings. There are 12 banks for settings. The bank selected by this register is used to make read or write access to registers or make settings of NEWMODE reception. The value of this register following a reset is 00H.

Figure 4-215 Format of NEWMODE Reception Control Register 1 (BBNMRXCON1)

Address: 01F3H After reset: 00H R/W

Symbol	7	6	5	4	3	2	1	0
BBNMRX CON1	0	0	0	0	NMRXBANK 3	NMRXBANK 2	NMRXBANK 1	NMRXBANK 0

NMRXBANK 3	NMRXBANK 2	NMRXBANK 1	NMRXBANK 0	NEWMODE reception setting switch
0	0	0	0	Bank 0 for settings
0	0	0	1	Bank 1 for settings
0	0	1	0	Bank 2 for settings
0	0	1	1	Bank 3 for settings
0	1	0	0	Bank 4 for settings
0	1	0	1	Bank 5 for settings
0	1	1	0	Bank 6 for settings
0	1	1	1	Bank 7 for settings
1	0	0	0	Bank 8 for settings
1	0	0	1	Bank 9 for settings
1	0	1	0	Bank 10 for settings
1	0	1	1	Bank 11 for settings
Other than above				Setting prohibited

**Caution** When writing to this register, set bits 7 to 4 to the value 0.



### 4.2.173 NEWMODE reception control register 2 (BBNMRXCON2)

The NEWMODE reception method selection bits are used to select the method of NEWMODE frame reception.

#### 0: FSK reception

The settings in the NEWMODE reception control register 1, NEWMODE reception frequency setting register, and NEWMODE reception FSK control registers 0 and 1 are used for reception.

#### 1: OFDM reception

The settings in the NEWMODE reception control register 1, NEWMODE reception frequency setting register, and NEWMODE reception OFDM control register are used for reception.

The IF frequency of NEWMODE reception can be specified by the NEWMODE reception IF frequency setting bits. The NEWMODE reception IF frequency offset enable bit enables or disables the setting of the offset value for the IF frequency in NEWMODE reception. The offset value is set according to the setting in IF frequency offset setting register 0 or 1. The NEWMODE reception IF frequency offset selection bit is used to select whether the value in IF frequency offset setting register 0 or 1 is to be used in NEWMODE reception. The NEWMODE reception DDC clock division ratio selection bits are used to select the division ratio of the clock for the DDC for use in NEWMODE reception. See the latest application note which specifies the recommended register settings for use with this product. The value of this register following a reset is 00H.

**Figure 4-216 Format of NEWMODE Reception Control Register 2 (BBNMRXCON2) (1/2)**

Address: 01F4H After reset: 00H R/W

Symbol	7	6	5	4	3	2	1	0
BBNMRX CON2	0	NMRXOSC BFDDC DIVSEL2	NMRXOSC BFDDC DIVSEL1	NMRXOSC BFDDC DIVSEL0	NMIF OFSTSEL	NMIF OFSTEN	NMRX IFSET	NMRX MODE

NMRXOSC BFDDC DIVSEL2	NMRXOSC BFDDC DIVSEL1	NMRXOSC BFDDC DIVSEL0	NEWMODE reception DDC clock division ratio selection
0	0	0	Division ratio is 12.
0	0	1	Division ratio is 13.
0	1	0	Division ratio is 14.
0	1	1	Division ratio is 11.
1	0	0	Division ratio is 10.
1	0	1	Division ratio is 9.
1	1	0	Setting prohibited
1	1	1	Setting prohibited

Figure 4-217 Format of NEWMODE Reception Control Register 2 (BBNMRXCON2) (2/2)

NMIF OFSTSEL	NEWMODE reception IF frequency offset selection
0	The value in IF frequency offset setting register 0 is to be used.
1	The value in IF frequency offset setting register 1 is to be used.

NMIF OFSTEN	NEWMODE reception IF frequency offset enable
0	IF frequency offset value setting is disabled.
1	IF frequency offset value setting is enabled.

NMRX IFSET	NEWMODE reception IF frequency setting
0	550 kHz
1	750 kHz

NMRX MODE	NEWMODE reception method selection
0	FSK reception
1	OFDM reception

**Caution** When writing to this register, set bit 7 to the value 0.

### 4.2.174 NEWMODE reception frequency setting register (BBNMRXBBFREQ)

This register is used to set the frequency of NEWMODE reception after the reception of a mode switch frame. This register consists of 30 bits. The frequency can be set in 1-Hz steps. The initial value is 36FC3BA0H = 922.5 MHz. Set a value from 337055C0H (863 MHz) to 37502800H (928 MHz). All four bytes should be specified starting from the lowest-order address. The value of this register following a reset is 36FC3BA0H.

Figure 4-218 Format of NEWMODE Reception Frequency Setting Register (BBNMRXBBFREQ)

Address: 01F8H to 01F5H After reset: 36FC3BA0H R/W

Symbol	31	30	29	28	27	26	25	24
BBNMRX BBFREQ (01F8H)	0	0	NMRXFREQ	NMRXFREQ	NMRXFREQ	NMRXFREQ	NMRXFREQ	NMRXFREQ
			29	28	27	26	25	24
(01F7H)	23	22	21	20	19	18	17	16
	NMRXFREQ	NMRXFREQ	NMRXFREQ	NMRXFREQ	NMRXFREQ	NMRXFREQ	NMRXFREQ	NMRXFREQ
(01F6H)	15	14	13	12	11	10	9	8
	NMRXFREQ	NMRXFREQ	NMRXFREQ	NMRXFREQ	NMRXFREQ	NMRXFREQ	NMRXFREQ	NMRXFREQ
(01F5H)	7	6	5	4	3	2	1	0
	NMRXFREQ	NMRXFREQ	NMRXFREQ	NMRXFREQ	NMRXFREQ	NMRXFREQ	NMRXFREQ	NMRXFREQ
NMRXFREQ29 to NMRXFREQ0			NEWMODE reception frequency setting					
—			Frequency of NEWMODE reception					

**Caution** When writing to this register, set bits 31 and 30 to the value 0.

### 4.2.175 NEWMODE reception FSK control register 0 (BBNMRXFSKCON0)

The NEWMODE reception FSK modulation index setting bit is used to specify the modulation index for NEWMODE FSK reception. The rate of NEWMODE FSK data reception can be selected by the NEWMODE reception FSK data rate selection bits. The value of this register following a reset is 00H.

**Figure 4-219 Format of NEWMODE Reception FSK Control Register 0 (BBNMRXFSKCON0)**

Address: 01F9H After reset: 00H R/W

Symbol	7	6	5	4	3	2	1	0
BBNMRX FSKCON0	0	0	0	NMRXFSK RATE3	NMRXFSK RATE2	NMRXFSK RATE1	NMRXFSK RATE0	NMRXFSK INDEX

NMRXFSK RATE3	NMRXFSK RATE2	NMRXFSK RATE1	NMRXFSK RATE0	NEWMODE reception FSK data rate selection
0	0	0	0	50 kbps
0	0	0	1	100 kbps
0	0	1	0	150 kbps
0	0	1	1	200 kbps
0	1	0	0	10 kbps
0	1	0	1	20 kbps
0	1	1	0	Setting prohibited
0	1	1	1	Setting prohibited
1	0	0	0	9.6 kbps
1	0	0	1	19.2 kbps
1	0	1	0	38.4 kbps
1	0	1	1	115.2 kbps
1	1	0	0	Setting prohibited
1	1	0	1	Setting prohibited
1	1	1	0	Setting prohibited
1	1	1	1	Setting prohibited

NMRXFSK INDEX	NEWMODE reception FSK modulation index setting
0	0.5
0	1.0

**Caution** When writing to this register, set bits 7 to 5 to the value 0.

#### 4.2.176 NEWMODE reception FSK control register 1 (BBNMRXFSKCON1)

The NEWMODE reception FSK reception FEC enable bit enables FEC (CODE) for NEWMODE FSK reception. The NEWMODE reception FSKFEC mode switch bit is used to switch the mode of FEC encoding for NEWMODE FSK reception. The NEWMODE reception FSK interleaving enable bit enables interleaving for NEWMODE FSK reception. The NEWMODE reception automatic FEC detection enable bit is used to detect whether FEC is enabled in NEWMODE FSK reception. The NEWMODE reception MRFSKSFD selection bit specifies the phyMRFSKSFD value for NEWMODE FSK reception. The NEWMODE reception MS bit forcible clear bit is used to forcibly clear the received MS bit to 0. The value of this register following a reset is 20H.

**Figure 4-220 Format of NEWMODE Reception FSK Control Register 1 (BBNMRXFSKCON1) (1/2)**

Address: 01FAH After reset: 20H R/W

Symbol	7	6	5	4	3	2	1	0
BBNMRX FSKCON1	0	0	NMRX FORCEMS	NMRX MRFSKSFD	NMRXFEC AUTOEN	NMRXFSK INTLVEN	NMRXFSK FECMODE	NMFSK FECENRX

NMRX FORCEMS	NEWMODE reception MS bit forcible clear
0	The MS bit is not forcibly cleared to 0.
1	The MS bit is forcibly cleared to 0.

NMRX MRFSKSFD	NEWMODE reception MRFSKSFD selection
0	phyMRFSKSFD = 0
1	phyMRFSKSFD = 1

NMRXFEC AUTOEN	NEWMODE reception automatic FEC detection enable
0	Detection is disabled.
1	Detection is enabled.

Figure 4-221 Format of NEWMODE Reception FSK Control Register 1 (BBNMRXFSKCON1) (2/2)

NMRXFS KINTLVEN	NEWMODE reception FSK interleaving enable
0	Interleaving is disabled.
1	Interleaving is enabled.

NMRXFSK FECMODE	NEWMODE reception FSKFEC mode switch
0	NRNSC encoder
1	RSC encoder

NMFSK FECENRX	NEWMODE reception FSK reception FEC enable
0	FEC is disabled.
1	FEC is enabled.

**Caution** When writing to this register, set bits 7 and 6 to the value 0.

#### 4.2.177 NEWMODE reception OFDM control register (BBNMRXOFDMCON)

The NEWMODE reception number-of-OFDMCRC-bit switch bit selects the number of bits for the CRC calculation process in OFDM reception. The NEWMODE reception OFDMOPTION setting bits are used to set the option value for OFDM reception as follows.

b1 b0

0 0: Option 1

0 1: Option 2

1 0: Option 3

1 1: Option 4

The NEWMODE reception OFDM interleaving setting bit is used to set the interleaving value for OFDM reception.

The NEWMODE reception OFDM extended mode bit is used to select an internal setting for OFDM modulation in NEWMODE reception. When any of option-3 MCS0, option-4 MCS0, or option-4 MCS1 is selected, set this bit to 1. Otherwise, set this bit to 0. The value of this register following a reset is 00H.

**Figure 4-222 Format of NEWMODE Reception OFDM Control Register (BBNMRXOFDMCON) (1/2)**

Address: 01FBH After reset: 00H R/W

Symbol	7	6	5	4	3	2	1	0
BBNMRX OFDMCON	0	0	0	NMRXOFDM EXT	NMRXOFDM INTERLEAVI NG	NMRXOFDM OPTION1	NMRXOFDM OPTION0	NMRXOFDM CRCBIT

NMRXOFDM EXT	NEWMODE reception OFDM extended mode
0	For other cases than those described below
1	For option-3 MCS0, option-4 MCS0, and option-4 MCS1

NMRXOFDM INTERLEAVING	NEWMODE reception OFDM interleaving setting
—	Interleaving value

NMRXOFDM OPTION1	NMRXOFDM OPTION0	NEWMODE reception OFDMOPTION setting
0	0	Option 1
0	1	Option 2
1	0	Option 3
1	1	Option 4

Figure 4-223 Format of NEWMODE Reception OFDM Control Register (BBNMRXOFDMCON) (2/2)

NMRXOFDM CRCBIT	NEWMODE reception number-of-OFDMCRC-bit switch
0	32-bit CRC
1	16-bit CRC

**Caution** When writing to this register, set bits 7 to 5 to the value 0.



### 4.2.178 Preamble length setting register (BBPAMBL)

This register is used to set the preamble length for transmission. Set a value from 0004H to 03E8H as the number of preamble bytes. The value of this register following a reset is 0004H.

**Figure 4-224 Format of Preamble Length Setting Register (BBPAMBL)**

Address: 0446H, 0445H After reset: 0004H R/W

Symbol	15	14	13	12	11	10	9	8
BBPAMBL (0446H)	0	0	0	0	0	0	PAMBLEN9	PAMBLEN8
	7	6	5	4	3	2	1	0
(0445H)	PAMBLEN7	PAMBLEN6	PAMBLEN5	PAMBLEN4	PAMBLEN3	PAMBLEN2	PAMBLEN1	PAMBLEN0
	PAMBLEN9 to PAMBLEN0		Preamble length					

**Caution** When writing to this register, set bits 15 to 10 to the value 0.

### 4.2.179 Preamble setting register (BBPABL)

This register is used to set the preamble value (LSB first). This register consists of 8 bits. The value of this register following a reset is AAH.

**Figure 4-225 Format of Preamble Setting Register (BBPABL)**

Address: 0447H After reset: AAH R/W

Symbol	7	6	5	4	3	2	1	0
BBPABL	PABL7	PABL6	PABL5	PABL4	PABL3	PABL2	PABL1	PABL0
	PABL7 to PABL0							Preamble value

### 4.2.180 TXSFD setting register (BBTXSFD)

This register is used to set the SFD value for transmission of an FEC disabled frame when the MRFSKSFD bit is 0. This register consists of 32 bits. Set this register to 904E0000H. The value of this register following a reset is 904E0000H.

**Figure 4-226 Format of TXSFD Setting Register (BBTXSFD)**

Address: 044BH to 0448H After reset: 904E0000H R/W

Symbol	31	30	29	28	27	26	25	24
BBTXSFD (044BH)	TSFD31	TSFD30	TSFD29	TSFD28	TSFD27	TSFD26	TSFD25	TSFD24
	23	22	21	20	19	18	17	16
(044AH)	TSFD23	TSFD22	TSFD21	TSFD20	TSFD19	TSFD18	TSFD17	TSFD16
	15	14	13	12	11	10	9	8
(0449H)	TSFD15	TSFD14	TSFD13	TSFD12	TSFD11	TSFD10	TSFD9	TSFD8
	7	6	5	4	3	2	1	0
(0448H)	TSFD7	TSFD6	TSFD5	TSFD4	TSFD3	TSFD2	TSFD1	TSFD0
	TSFD31 to TSFD0		SFD value for transmission					

### 4.2.181 TXSFD setting register 2 (BBTXSFD2)

This register is used to set the SFD value for transmission of an FEC enabled frame when the MRFSKSFD bit is 0. This register consists of 32 bits. Set this register to 6F4E0000H. The value of this register following a reset is 6F4E0000H.

**Figure 4-227 Format of TXSFD Setting Register 2 (BBTXSFD2)**

Address: 044FH to 044CH After reset: 6F4E0000H R/W

Symbol	31	30	29	28	27	26	25	24
BBTXSFD2 (044FH)	TSFD231	TSFD230	TSFD229	TSFD228	TSFD227	TSFD226	TSFD225	TSFD224
	23	22	21	20	19	18	17	16
(044EH)	TSFD223	TSFD222	TSFD221	TSFD220	TSFD219	TSFD218	TSFD217	TSFD216
	15	14	13	12	11	10	9	8
(044DH)	TSFD215	TSFD214	TSFD213	TSFD212	TSFD211	TSFD210	TSFD209	TSFD208
	7	6	5	4	3	2	1	0
(044CH)	TSFD207	TSFD206	TSFD205	TSFD204	TSFD203	TSFD202	TSFD201	TSFD200
	TSFD231 to TSFD200		SFD2 value for transmission					

### 4.2.182 TXSFD setting register 3 (BBTXSFD3)

This register is used to set the SFD value for transmission of an FEC disabled frame when the MRFSKSFDF bit is 1. This register consists of 32 bits. Set this register to 7A0E0000H. The value of this register following a reset is 7A0E0000H.

**Figure 4-228 Format of TXSFD Setting Register 3 (BBTXSFD3)**

Address: 0453H to 0450H After reset: 7A0E0000H R/W

Symbol	31	30	29	28	27	26	25	24
BBTXSFD3 (0453H)	TSFD331	TSFD330	TSFD329	TSFD328	TSFD327	TSFD326	TSFD325	TSFD324
	23	22	21	20	19	18	17	16
(0452H)	TSFD323	TSFD322	TSFD321	TSFD320	TSFD319	TSFD318	TSFD317	TSFD316
	15	14	13	12	11	10	9	8
(0451H)	TSFD315	TSFD314	TSFD313	TSFD312	TSFD311	TSFD310	TSFD309	TSFD308
	7	6	5	4	3	2	1	0
(0450H)	TSFD307	TSFD306	TSFD305	TSFD304	TSFD303	TSFD302	TSFD301	TSFD300
	TSFD331 to TSFD300		SFD3 value for transmission					

### 4.2.183 TXSFD setting register 4 (BBTXSFD4)

This register is used to set the SFD value for transmission of an FEC enabled frame when the MRFSKSFD bit is 1. This register consists of 32 bits. Set this register to 632D0000H. The value of this register following a reset is 632D0000H.

**Figure 4-229 Format of TXSFD Setting Register 4 (BBTXSFD4)**

Address: 0460H to 045EH, 0454H After reset: 632D0000H R/W

Symbol	31	30	29	28	27	26	25	24
BBTXSFD4 (0460H)	TSFD431	TSFD430	TSFD429	TSFD428	TSFD427	TSFD426	TSFD425	TSFD424
	23	22	21	20	19	18	17	16
(045FH)	TSFD423	TSFD422	TSFD421	TSFD420	TSFD419	TSFD418	TSFD417	TSFD416
	15	14	13	12	11	10	9	8
(045EH)	TSFD415	TSFD414	TSFD413	TSFD412	TSFD411	TSFD410	TSFD409	TSFD408
	7	6	5	4	3	2	1	0
(0454H)	TSFD407	TSFD406	TSFD405	TSFD404	TSFD403	TSFD402	TSFD401	TSFD400
	TSFD431 to TSFD400		SFD4 value for transmission					

#### 4.2.184 SHR control register (BBSHRCON)

The number-of-SFD-byte setting bits are used to set the number of bytes in the SFD setting<sup>Note 1</sup> to be output as the SFD pattern.

00: 1 byte (bits 31 to 24 of the SFD setting<sup>Note 1</sup>)

01: 2 bytes (bits 31 to 16 of the SFD setting<sup>Note 1</sup>)

10: 3 bytes (bits 31 to 8 of the SFD setting<sup>Note 1</sup>)

11: 4 bytes (bits 31 to 0 of the SFD setting<sup>Note 1</sup>)

The value of this register following a reset is 01H.

**Note 1. TXSFD setting register, and TXSFD setting registers 2 to 4**

**Figure 4-230 Format of SHR Control Register (BBSHRCON)**

Address: 0461H After reset: 01H R/W

Symbol	7	6	5	4	3	2	1	0
BBSHR CON	0	0	0	0	0	0	SFDBYTE1	SFDBYTE0

SFDBYTE1	SFDBYTE0	Number-of-SFD-byte setting
0	0	1 byte
0	1	2 bytes
1	0	3 bytes
1	1	4 bytes

**Caution** When writing to this register, set bits 7 to 2 to the value 0.

### 4.2.185 NEWMODE transmission FSK preamble length setting register (BBMSPAMBL)

This register is used to set the preamble length for NEWMODE frame transmission after the transmission of a mode switch frame. Set a value from 0004H to 03E8H as the number of preamble bytes. The value of this register following a reset is 0010H.

**Figure 4-231 Format of NEWMODE Transmission FSK Preamble Length Setting Register (BBMSPAMBL)**

Address: 0475H, 0474H After reset: 0010H R/W

Symbol	15	14	13	12	11	10	9	8
BBMSPAMBL (0475H)	0	0	0	0	0	0	MSPAMBL LEN9	MSPAMBL LEN8
(0474H)	7	6	5	4	3	2	1	0
	MSPAMBL LEN7	MSPAMBL LEN6	MSPAMBL LEN5	MSPAMBL LEN4	MSPAMBL LEN3	MSPAMBL LEN2	MSPAMB LLEN1	MSPAMBL LEN0
	MSPAMBLEN9 to MSPAMBLEN0		Preamble length for NEWMODE frame transmission					

**Caution** When writing to this register, set bits 15 to 10 to the value 0.



### 4.2.186 Version code read control register (VERCNT)

This register is used to control the operation of reading the 8-byte version code prepared for identification of the LSI chip through the SPI. The value of this register following a reset is 00H.

Figure 4-232 Format of Version Code Read Control Register (VERCNT)

Address: 04DEH After reset: 00H R/W<sup>Note</sup>

Symbol	7	6	5	4	3	2	1	0
VERCNT	0	0	0	CGCEN	0	0	ENDSEQ	STARTSEQ

CGCEN	Version code read enable
0	Reading is disabled.
1	Reading is enabled.

ENDSEQ	Version code read end flag
0	Reading has not been started or is in progress.
1	Reading has been completed.

STARTSEQ	Version code read operation start
0	Reading is stopped.
1	Reading is started.

**Note:** Bit 1 is read-only.

**Caution** When writing to this register, set bits 7 to 5, 3, and 2 to the value 0.

### 4.2.187 Version registers (VERR0 to VERR7)

An 8-byte version code is stored in these registers. The user cannot modify the register values. The following shows the procedure for reading the version registers. After a command for reading is issued, the values of the version registers are retained until this device is reset.

Figure 4-233 Procedure for Reading the Version Registers (VERR0 to VERR7)

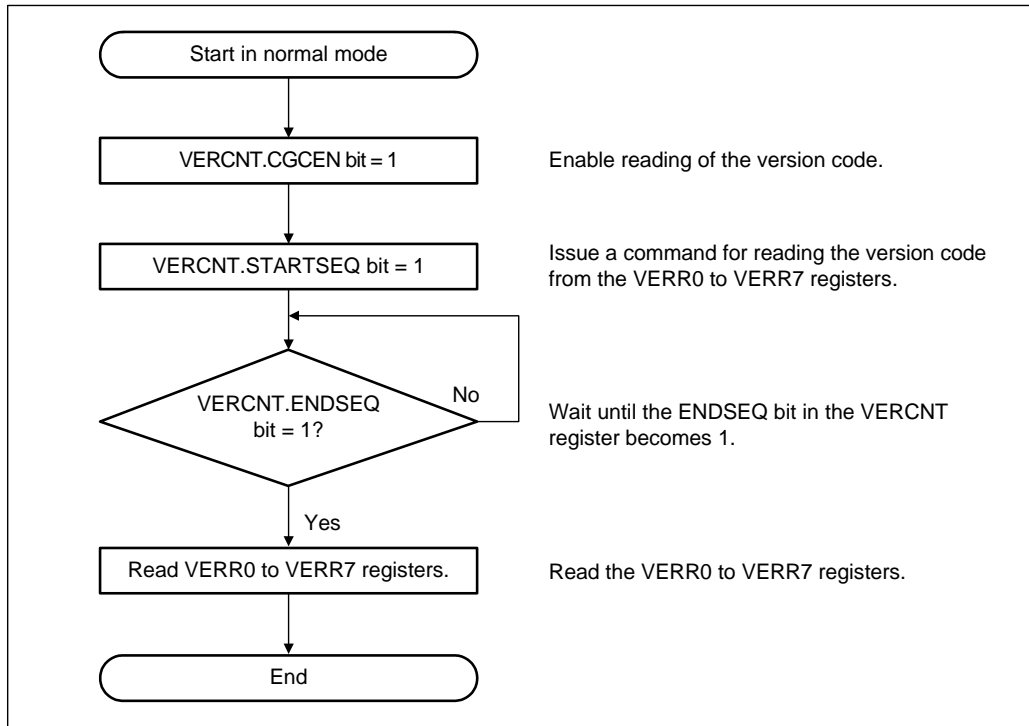
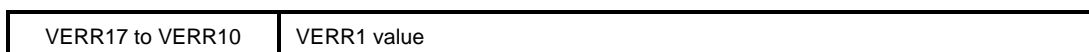
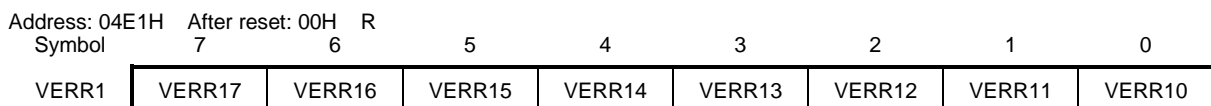
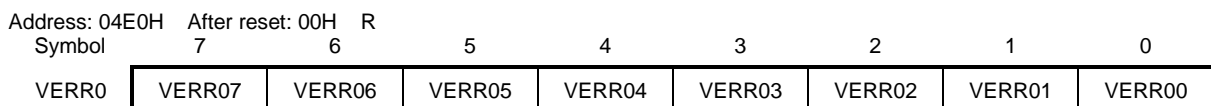

Figure 4-234 Format of Version Registers (VERR0 to VERR7)



Address: 04E2H After reset: 00H R  
Symbol 7 6 5 4 3 2 1 0

VERR2	VERR27	VERR26	VERR25	VERR24	VERR23	VERR22	VERR21	VERR20
VERR27 to VERR20				VERR2 value				

Address: 04E3H After reset: 00H R  
Symbol 7 6 5 4 3 2 1 0

VERR3	VERR37	VERR36	VERR35	VERR34	VERR33	VERR32	VERR31	VERR30
VERR37 to VERR30				VERR3 value				

Address: 04E4H After reset: 00H R  
Symbol 7 6 5 4 3 2 1 0

VERR4	VERR47	VERR46	VERR45	VERR44	VERR43	VERR42	VERR41	VERR40
VERR47 to VERR40				VERR4 value				

Address: 04E5H After reset: 00H R  
Symbol 7 6 5 4 3 2 1 0

VERR5	VERR57	VERR56	VERR55	VERR54	VERR53	VERR52	VERR51	VERR50
VERR57 to VERR50				VERR5 value				

Address: 04E6H After reset: 00H R  
Symbol 7 6 5 4 3 2 1 0

VERR6	VERR67	VERR66	VERR65	VERR64	VERR63	VERR62	VERR61	VERR60
VERR67 to VERR60				VERR6 value				

Address: 04E7H After reset: 00H R  
Symbol 7 6 5 4 3 2 1 0

VERR7	VERR77	VERR76	VERR75	VERR74	VERR73	VERR72	VERR71	VERR70
VERR77 to VERR70				VERR7 value				

#### 4.2.188 RXSFD setting register 2 (BBRXSFD2)

This register is used to set the SFD value for reception of an FEC enabled frame when the MRFSKSFD bit is 0. This register consists of 32 bits. Set this register to 55556F4EH. When using a 16-bit value as the SFD, specify the preamble value (5555H) in the higher-order 16 bits (RSFD231 to RSFD216). When using a 17-bit to 32-bit value as the SFD, specify the preamble value in the higher-order unused bits.

Examples:

17-bit SFD: Specify 5555H in the RSFD231 to RSFD217 bits.

25-bit SFD: Specify 55H in the RSFD231 to RSFD225 bits

Specify an SFD pattern that differs in at least six bits from the SFD value for FEC disabled frames when the MRFSKSFD bit is 0. The value of this register following a reset is 55556F4EH.

**Figure 4-235 Format of RXSFD Setting Register 2 (BBRXSFD2)**

Bank number: 0 Address: 08F0H to 08F3H After reset: 55556F4EH R/W

Symbol	31	30	29	28	27	26	25	24
BBRXSFD2 (08F0H)	RSFD231	RSFD230	RSFD229	RSFD228	RSFD227	RSFD226	RSFD225	RSFD224
	23	22	21	20	19	18	17	16
(08F1H)	RSFD223	RSFD222	RSFD221	RSFD220	RSFD219	RSFD218	RSFD217	RSFD216
	15	14	13	12	11	10	9	8
(08F2H)	RSFD215	RSFD214	RSFD213	RSFD212	RSFD211	RSFD210	RSFD209	RSFD208
	7	6	5	4	3	2	1	0
(08F3H)	RSFD207	RSFD206	RSFD205	RSFD204	RSFD203	RSFD202	RSFD201	RSFD200
	RSFD231 to RSFD200		SFD2 value for reception					

### 4.2.189 RXSFD setting register (BBRXSFD)

This register is used to set the SFD value for reception of an FEC disabled frame when the MRFSKSFD bit is 0. This register consists of 32 bits. Set this register to 5555904EH. When using a 16-bit value as the SFD, specify the preamble value (5555H) in the higher-order 16 bits (SFD31 to SFD16). When using a 17-bit to 32-bit value as the SFD, specify the preamble value in the higher-order unused bits.

Examples:

17-bit SFD: Specify 5555H in the RSFD31 to RSFD17 bits.

25-bit SFD: Specify 55H in the RSFD31 to RSFD25 bits

Specify an SFD pattern that differs in at least six bits from the SFD value for FEC enabled frames when the MRFSKSFD bit is 0. The value of this register following a reset is 5555904EH.

**Figure 4-236 Format of RXSFD Setting Register (BBRXSFD)**

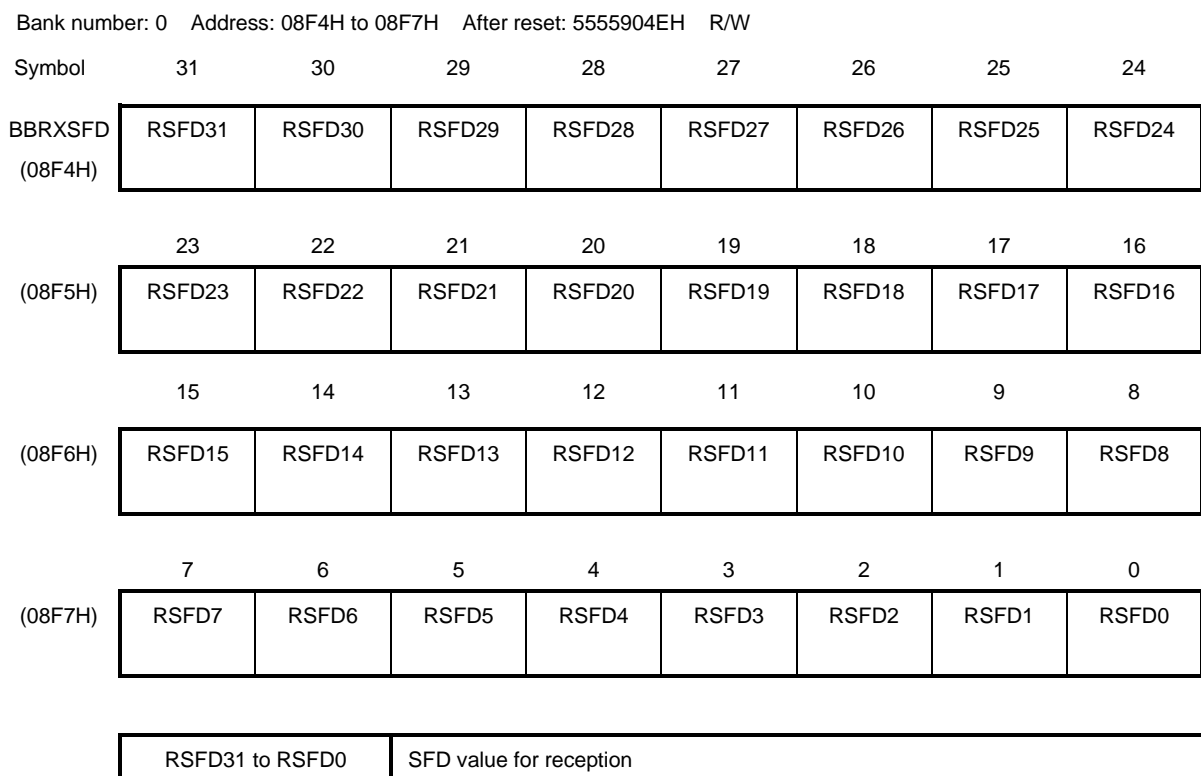

#### 4.2.190 RXSFD setting register 4 (BBRXSFD4)

This register is used to set the SFD value for reception of an FEC enabled frame when the MRFSKSFD bit is 1. This register consists of 32 bits. Set this register to 5555632DH. When using a 16-bit value as the SFD, specify the preamble value (5555H) in the higher-order 16 bits (RSFD431 to RSFD416). When using a 17-bit to 32-bit value as the SFD, specify the preamble value in the higher-order unused bits.

Examples:

17-bit SFD: Specify 5555H in the RSFD431 to RSFD417 bits.

25-bit SFD: Specify 55H in the RSFD431 to RSFD425 bits

Specify an SFD pattern that differs in at least six bits from the SFD value for FEC disabled frames when the MRFSKSFD bit is 1. The value of this register following a reset is 5555632DH.

**Figure 4-237 Format of RXSFD Setting Register 4 (BBRXSFD4)**

Bank number: 0 Address: 08F8H to 08FBH After reset: 5555632DH R/W

Symbol	31	30	29	28	27	26	25	24
BBRXSFD4 (08F8H)	RSFD431	RSFD430	RSFD429	RSFD428	RSFD427	RSFD426	RSFD425	RSFD424
	23	22	21	20	19	18	17	16
(08F9H)	RSFD423	RSFD422	RSFD421	RSFD420	RSFD419	RSFD418	RSFD417	RSFD416
	15	14	13	12	11	10	9	8
(08FAH)	RSFD415	RSFD414	RSFD413	RSFD412	RSFD411	RSFD410	RSFD409	RSFD408
	7	6	5	4	3	2	1	0
(08FBH)	RSFD407	RSFD406	RSFD405	RSFD404	RSFD403	RSFD402	RSFD401	RSFD400
	RSFD431 to RSFD400		SFD4 value for reception					

### 4.2.191 RXSFD setting register 3 (BBRXSFD3)

This register is used to set the SFD value for reception of an FEC disabled frame when the MRFSKSFD bit is 1. This register consists of 32 bits. Set this register to 55557A0EH. When using a 16-bit value as the SFD, specify the preamble value (5555H) in the higher-order 16 bits (RSFD331 to RSFD316). When using a 17-bit to 32-bit value as the SFD, specify the preamble value in the higher-order unused bits.

Examples:

17-bit SFD: Specify 5555H in the RSFD331 to RSFD317 bits.

25-bit SFD: Specify 55H in the RSFD331 to RSFD325 bits

Specify an SFD pattern that differs in at least six bits from the SFD value for FEC enabled frames when the MRFSKSFD bit is 1. The value of this register following a reset is 55557A0EH.

**Figure 4-238 Format of RXSFD Setting Register 3 (BBRXSFD3)**

Bank number: 0 Address: 08FCH to 08FFH After reset: 55557A0EH R/W

Symbol	31	30	29	28	27	26	25	24
BBRXSFD3 (08FCH)	RSFD331	RSFD330	RSFD329	RSFD328	RSFD327	RSFD326	RSFD325	RSFD324
	23	22	21	20	19	18	17	16
(08FDH)	RSFD323	RSFD322	RSFD321	RSFD320	RSFD319	RSFD318	RSFD317	RSFD316
	15	14	13	12	11	10	9	8
(08FEH)	RSFD315	RSFD314	RSFD313	RSFD312	RSFD311	RSFD310	RSFD309	RSFD308
	7	6	5	4	3	2	1	0
(08FFH)	RSFD307	RSFD306	RSFD305	RSFD304	RSFD303	RSFD302	RSFD301	RSFD300
	RSFD331 to RSFD300		SFD3 value for reception					

### 5. Package Outline Drawings

JEITA Package code	RENESAS code	MASS(TYP.)[g]
P-HWQFN040-6x6-0.50	PWQN0040KD-A	0.08

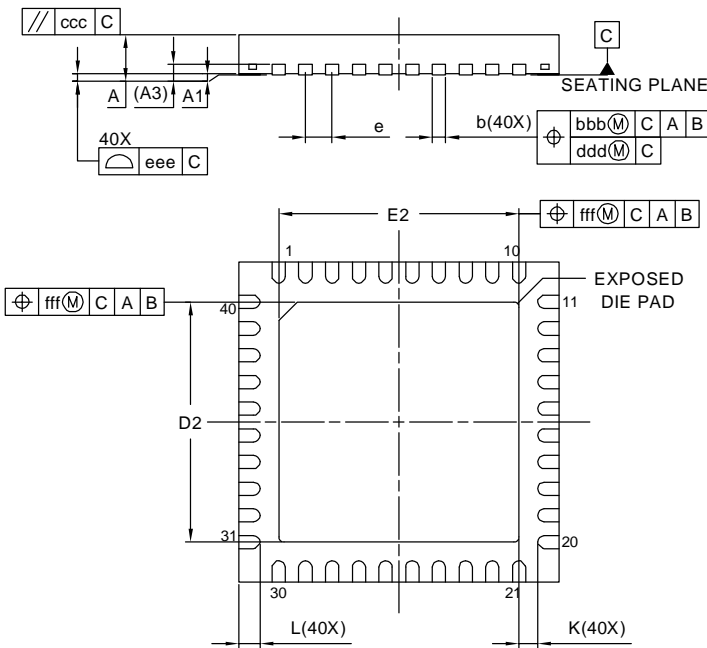
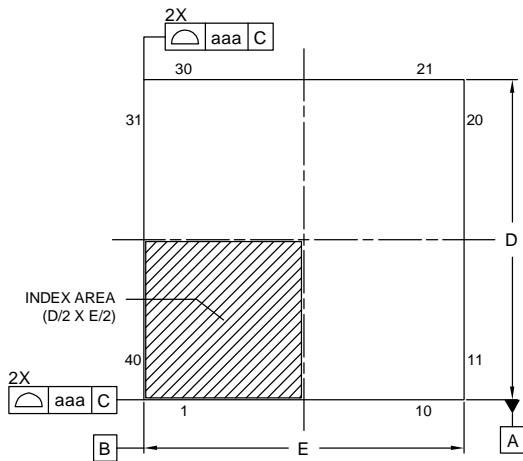

Reference Symbol	Dimension in Millimeters		
	Min.	Nom.	Max.
A	—	—	0.80
A <sub>1</sub>	0.00	0.02	0.05
A <sub>3</sub>	0.203 REF.		
b	0.18	0.25	0.30
D	6.00 BSC		
E	6.00 BSC		
e	0.50 BSC		
L	0.30	0.40	0.50
K	0.20	—	—
D <sub>2</sub>	4.45	4.50	4.55
E <sub>2</sub>	4.45	4.50	4.55
aaa	0.15		
bbb	0.10		
ccc	0.10		
ddd	0.05		
eee	0.08		
fff	0.10		



## 6. Ordering Information

Ordering Part Number	Packaging Specification	Fields of application
R9A06G062GNP#AC1	Tray	Industrial applications

## Revision History

Revision	Date	Description
1.00	June 28, 2024	First edition issued.

## IMPORTANT NOTICE AND DISCLAIMER

RENESAS ELECTRONICS CORPORATION AND ITS SUBSIDIARIES (“RENESAS”) PROVIDES TECHNICAL SPECIFICATIONS AND RELIABILITY DATA (INCLUDING DATASHEETS), DESIGN RESOURCES (INCLUDING REFERENCE DESIGNS), APPLICATION OR OTHER DESIGN ADVICE, WEB TOOLS, SAFETY INFORMATION, AND OTHER RESOURCES “AS IS” AND WITH ALL FAULTS, AND DISCLAIMS ALL WARRANTIES, EXPRESS OR IMPLIED, INCLUDING, WITHOUT LIMITATION, ANY IMPLIED WARRANTIES OF MERCHANTABILITY, FITNESS FOR A PARTICULAR PURPOSE, OR NON-INFRINGEMENT OF THIRD-PARTY INTELLECTUAL PROPERTY RIGHTS.

These resources are intended for developers who are designing with Renesas products. You are solely responsible for (1) selecting the appropriate products for your application, (2) designing, validating, and testing your application, and (3) ensuring your application meets applicable standards, and any other safety, security, or other requirements. These resources are subject to change without notice. Renesas grants you permission to use these resources only to develop an application that uses Renesas products. Other reproduction or use of these resources is strictly prohibited. No license is granted to any other Renesas intellectual property or to any third-party intellectual property. Renesas disclaims responsibility for, and you will fully indemnify Renesas and its representatives against, any claims, damages, costs, losses, or liabilities arising from your use of these resources. Renesas' products are provided only subject to Renesas' Terms and Conditions of Sale or other applicable terms agreed to in writing. No use of any Renesas resources expands or otherwise alters any applicable warranties or warranty disclaimers for these products.

(Disclaimer Rev.1.01 Jan 2024)

### Corporate Headquarters

TOYOSU FORESIA, 3-2-24 Toyosu,  
Koto-ku, Tokyo 135-0061, Japan  
[www.renesas.com](http://www.renesas.com)

### Trademarks

Renesas and the Renesas logo are trademarks of Renesas Electronics Corporation. All trademarks and registered trademarks are the property of their respective owners.

### Contact Information

For further information on a product, technology, the most up-to-date version of a document, or your nearest sales office, please visit [www.renesas.com/contact-us/](http://www.renesas.com/contact-us/).