

RAA211230

24V 3A Integrated Switching Regulator

The RAA211230 is an integrated 24V, 3A synchronous buck regulator with current mode constant on-time (COT) control. The RAA211230 features comprehensive protection that includes input undervoltage lockout (UVLO), overcurrent protection (OCP), output undervoltage protection (OUVP), and over-temperature protection (OTP).

The device is available in a 6 Ld TSOT23 package.

Applications

- General purpose
- Industrial power supplies
- Embedded systems and I/O supplies

Features

- 4.5V to 24V input supply range
- Up to 3A output current
- Integrated high-side (85mΩ) and low-side (45mΩ) MOSFETs
- 400μA quiescent current
- Minimum on-time of 60ns
- Minimum off-time of 275ns
- 0.765V reference voltage with 2% accuracy
- PFM mode under light load condition
- Current mode Constant On-Time (COT) control with internal compensation
- Internal 0.8ms soft-start time
- Protection: Low-Side Overcurrent (LSOC) limit, input Undervoltage Lockout (UVLO), Over-Temperature Protection (OTP), Output Undervoltage Protection (OUVP) with Hiccup Mode
- Accurate EN threshold
- 6 LD TSOT23 package

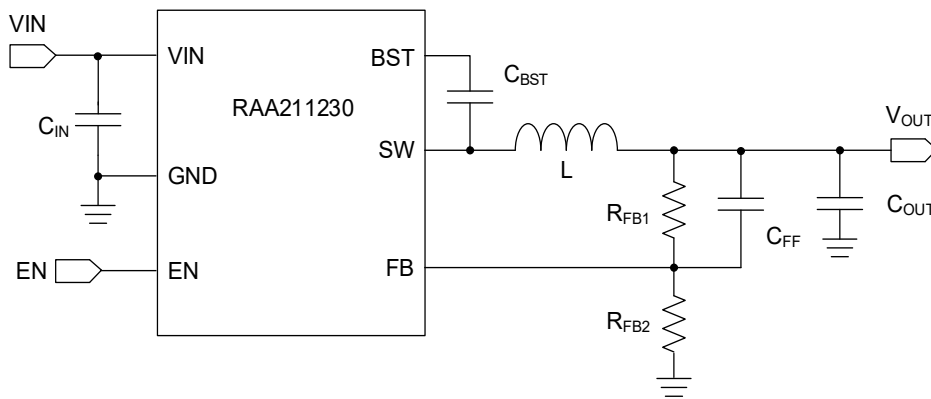

Figure 1. Typical Application Circuit Diagram

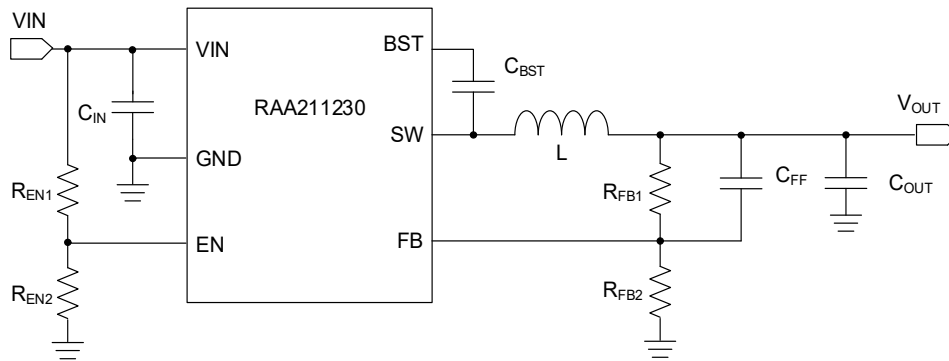

Figure 2. Typical Application Circuit Diagram with  $V_{IN}$  UVLO Programming by ENABLE

Table 1. Bill of Materials for Typical Application Circuit (3.3V  $V_{OUT}$ )

Item	Qty	Reference	Value	Description	Part number
1	1	$C_{IN}$	10 $\mu$ F	CAP CER 10 $\mu$ F 35V X7R 1206	GMK316AB7106KL-TR
2	1	$C_{OUT}$	22 $\mu$ F	CAP CER 22 $\mu$ F 6.3V X7R 0805	GRM21BZ70J226ME44L
3	1	$C_{BST}$	0.1 $\mu$ F	CAP CER 0.1 $\mu$ F 50V X7R 0603	885012206095
4	1	$L_1$	3.3 $\mu$ H	WE-HCI SMD High Current Inductor, 3.3 $\mu$ H, 20%	744311330
5	1	$R_{FB1}$	33.2K	1% resistor 0603	Generic
6	1	$R_{FB2}$	10K	1% resistor 0603	Generic
7		$C_{FF}$	-	DNP	-

## Contents

<b>1. Overview</b>	<b>4</b>
1.1 Block Diagram	4
<b>2. Pin Information</b>	<b>5</b>
2.1 Pin Assignments	5
2.2 Pin Descriptions	5
<b>3. Specifications</b>	<b>6</b>
3.1 Absolute Maximum Ratings	6
3.2 Thermal Information	6
3.3 Recommended Operating Conditions	6
3.4 Electrical Specifications	7
<b>4. Typical Performance Curves</b>	<b>8</b>
<b>5. Faults and Fault Handling Description</b>	<b>15</b>
5.1 System Level Fault Summary	15
<b>6. Functional Description</b>	<b>15</b>
6.1 Soft-Start	15
6.2 Undervoltage Lockout	15
6.3 Enable Control	15
6.4 Overcurrent Protection (OCP) and $V_{OUT}$ Undervoltage Protection	16
6.5 Over-Temperature Protection	16
<b>7. Applications Information</b>	<b>17</b>
7.1 Output Voltage Feedback Resistor Divider	17
7.2 Inductor Selection	18
7.3 Input Capacitor Selection	18
7.4 Output Capacitor Selection	19
7.5 BOOT Refresh and Capacitor Selection	20
<b>8. Component Placement and Layout Suggestions</b>	<b>21</b>
<b>9. Package Outline Drawing</b>	<b>22</b>
<b>10. Ordering Information</b>	<b>23</b>
<b>11. Revision History</b>	<b>23</b>

# 1. Overview

## 1.1 Block Diagram

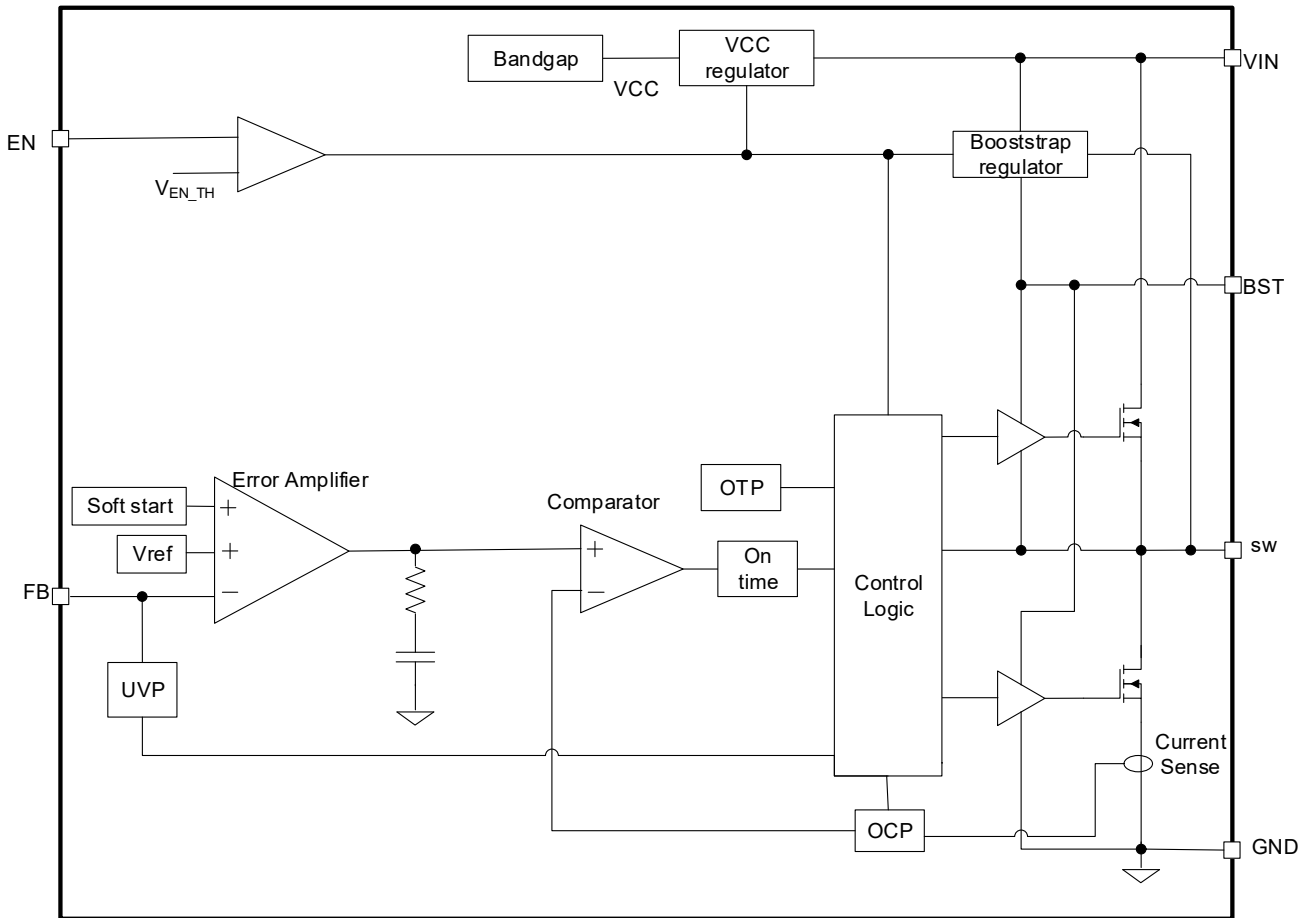
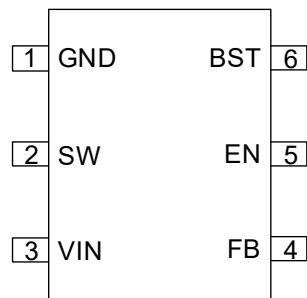

Figure 3. Functional Block Diagram

## 2. Pin Information

### 2.1 Pin Assignments



Top View

### 2.2 Pin Descriptions

Pin Number	Pin Name	Description
1	GND	Ground
2	SW	Switch node pin. Connect this pin to the output inductor and bootstrap capacitor.
3	VIN	Voltage input for the IC. Connect to a suitable voltage source within the IC operating range to this pin. Place a ceramic capacitor from VIN to GND close to the IC for decoupling.
4	FB	Feedback input pin for the regulator. The output voltage is set by an external resistor divider connected to FB. FB voltage is 0.765V during normal operation.
5	EN	Accurate enable signal.
6	BST	Bootstrap supply pin. Connect a 0.1µF capacitor from BST to SW.

### 3. Specifications

#### 3.1 Absolute Maximum Ratings

**Caution:** Do not operate at or near the maximum ratings listed for extended periods of time. Exposure to such conditions can adversely impact product reliability and result in failures not covered by warranty.

Parameter	Minimum	Maximum	Unit
VIN	-0.3	26	V
EN	-0.3	VIN + 0.3	V
SW	-0.7	26.3	V
SW (20ns transient)	-3	28	V
BST	-	SW + 5.5	V
All other pins	-0.3	5	V
Maximum Junction Temperature	-40	+150	°C
Maximum Storage Temperature Range	-65	+150	°C
Human Body Model (Tested per JS-001-2017)	-	2.5	kV
Charged Device Model (Tested per JS-002-2018)	-	1	kV
Latch-Up (Tested per JESD78E; Class 2, Level A)	-	100	mA

#### 3.2 Thermal Information

Parameter	Package	Symbol	Conditions	Typical Value	Unit
Thermal Resistance	6 Ld TSOT23	$\theta_{JA}^{[1]}$	Junction to air	105	°C/W
		$\theta_{JA\_EVB}^{[2]}$	Junction to air, evaluation board	51	°C/W
		$\theta_{JC}^{[3]}$	Junction to case	45	°C/W

- $\theta_{JA}$  is measured in free air with the component mounted on a high-effective thermal conductivity test board with direct attach features. See [TB379](#).
- $\theta_{JA\_EVB}$  is measured in free air with the component mounted on the RTKA211230DE0020BU evaluation board.
- For  $\theta_{JC}$ , the case temperature measurement location is the center of top of package.

#### 3.3 Recommended Operating Conditions

Parameter	Minimum	Maximum	Unit
Input Voltage, V <sub>IN</sub>	4.5	24	V
Output Voltage, V <sub>OUT</sub>	0.765	14	V
Output Current, I <sub>OUT</sub>	0	3	A
Junction Temperature, T <sub>J</sub>	-40	+125	°C

### 3.4 Electrical Specifications

$T_A = T_J = -40^{\circ}\text{C}$  to  $+125^{\circ}\text{C}$ ,  $V_{IN} = 12\text{V}$ , unless otherwise noted. Typical values are at  $T_A = +25^{\circ}\text{C}$ .

Parameter	Symbol	Test Conditions	Minimum <sup>[1]</sup>	Typical	Maximum <sup>[1]</sup>	Unit
<b>Supply Voltage</b>						
$V_{IN}$ Voltage Range	$V_{IN}$	-	4.5	-	24	V
Quiescent Current	$I_Q$	EN = 2V, $V_{FB} = 0.8\text{V}$ , no switching	-	400	-	$\mu\text{A}$
Shutdown Current	$I_{SH}$	EN = 0V, $V_{IN} = 12$ , no switching	-	1.5	5	$\mu\text{A}$
$V_{IN}$ Undervoltage Lockout	-	$V_{IN}$ Rising	-	4.3	4.55	V
$V_{IN}$ Undervoltage Hysteresis	-	$V_{IN}$ Falling	-	425	-	mV
<b>Output Voltage</b>						
$V_{OUT}$ Voltage Range	$V_{OUT}$	Subject to $t_{OFF\_MIN}, t_{ON\_MIN}$	$V_{FB}$	-	14	V
<b>Enable Voltage</b>						
EN Threshold Voltage	VEN	EN rising	1.2	1.3	1.45	V
Enable Voltage Hysteresis	-	-	-	0.1	-	V
Enable Shutdown Threshold	VENL	-	-	0.7	-	V
EN Pin Resistance to GND	REN	VEN = 2V	-	2000	-	k $\Omega$
<b>Switching Frequency and Timer Control</b>						
Switching Frequency Range	$f_{SW}$	$V_{FB} = 0.765\text{V}$ , $V_{OUT} = 1.05\text{V}$ , $I_{OUT} = 1\text{A}$ , $V_{IN} = 12\text{V}$	-	500	-	kHz
Minimum Off-Time	$t_{OFF\_MIN}$	-	-	275	380	ns
Minimum On-Time	$t_{ON\_MIN}$	-	-	60	-	ns
Internal Soft-Start Time	-	-	-	0.8	-	ms
<b>Feedback Voltage</b>						
Feedback Voltage Reference	$V_{FB}$	$V_{IN} = 12\text{V}$ , EN = 2V, $25^{\circ}\text{C}$	0.75	0.765	0.78	V
Feedback Voltage Line Regulation	-	-	-	$\pm 0.005$	-	%/V
<b>Internal Integrated MOSFETs</b>						
High-Side On-Resistance	$r_{DS(ON)_H}$	VBST - VSW = 5.1V	-	85	-	m $\Omega$
Low-Side On-Resistance	$r_{DS(ON)_L}$	-	-	45	-	m $\Omega$
<b>Current Limit and Protection</b>						
Current Limit	$I_{LIM\_L}$	Valley current, low-side FET, valid when $t_{OFF} > 100\text{ns}$	2.7	3.1	3.5	A
UVP	FB_UV	Fault threshold, $V_{FB}$ falling, soft-start completed	-	500	-	mV
Hiccup Soft-Start Done Time	$t_{HICCUP\_ON}$	-	-	1.25	-	ms
Hiccup Power Off-Time	$t_{HICCUP\_OFF}$	-	-	13	-	ms
Thermal Shutdown	TSD	-	-	170	-	$^{\circ}\text{C}$
Thermal hysteresis	$\Delta\text{TSD}$	-	-	20	-	$^{\circ}\text{C}$

1. Parameters with MIN and/or MAX limits are 100% tested at  $+25^{\circ}\text{C}$ , unless otherwise specified. Temperature limits established by characterization and are not production tested.

## 4. Typical Performance Curves

Typical Values are at  $T_A = +25^\circ\text{C}$ ,  $V_{IN} = 12\text{V}$ ,  $V_{OUT} = 3.3\text{V}$ ,  $I_{OUT} = 3\text{A}$ ,  $L = 3.3\mu\text{H}$ , unless otherwise noted.

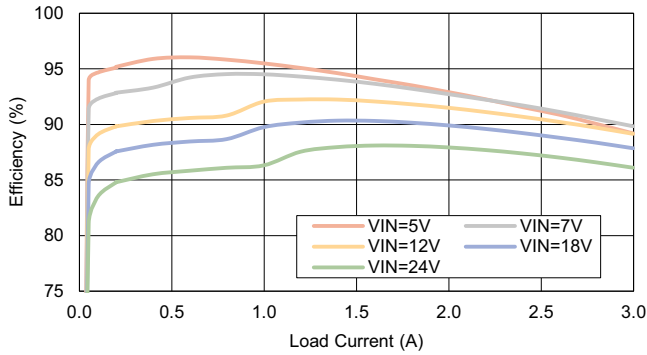

Figure 4. Efficiency vs Load Current ( $V_{OUT} = 3.3\text{V}$ )

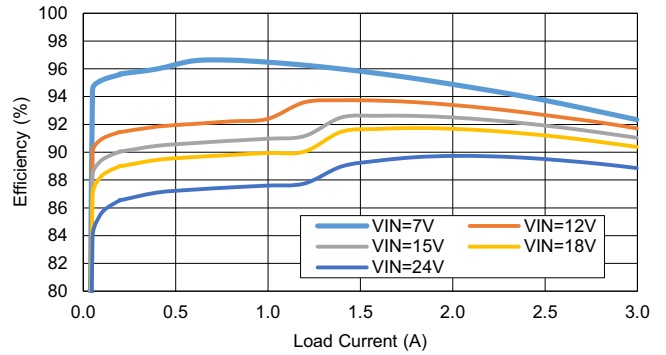

Figure 5. Efficiency vs Load Current ( $V_{OUT} = 5\text{V}$ )

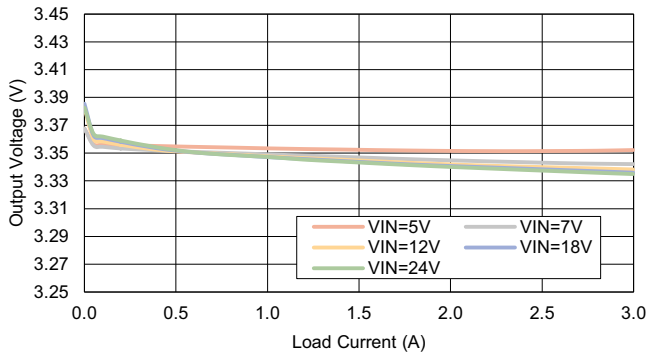

Figure 6. Load Regulation ( $V_{OUT} = 3.3\text{V}$ )

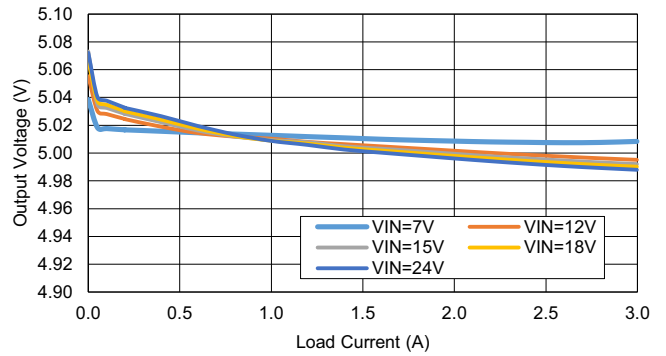

Figure 7. Load Regulation ( $V_{OUT} = 5\text{V}$ )

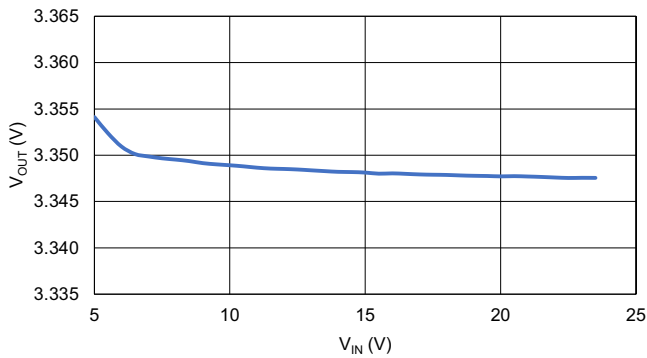

Figure 8. Line Regulation ( $V_{OUT} = 3.3\text{V}$ ,  $I_{OUT} = 1\text{A}$ )

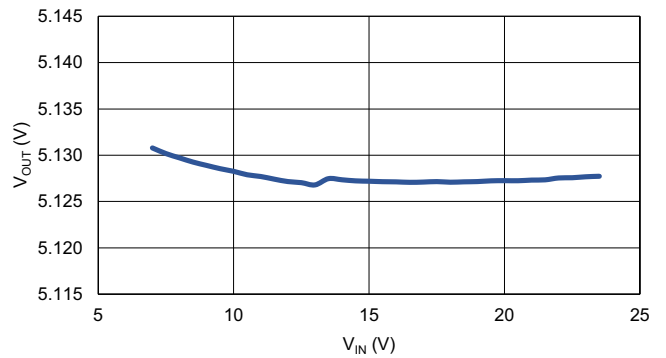

Figure 9. Line Regulation ( $V_{OUT} = 5\text{V}$ ,  $I_{OUT} = 1\text{A}$ )



Typical Values are at  $T_A = +25^\circ\text{C}$ ,  $V_{IN} = 12\text{V}$ ,  $V_{OUT} = 3.3\text{V}$ ,  $I_{OUT} = 3\text{A}$ ,  $L = 3.3\mu\text{H}$ , unless otherwise noted. (Cont.)

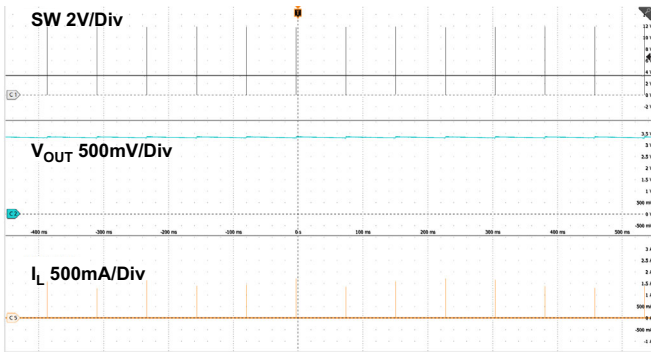

Figure 10. Steady-State Operation,  $I_{OUT} = 0\text{A}$   
( $V_{OUT} = 3.3\text{V}$ )

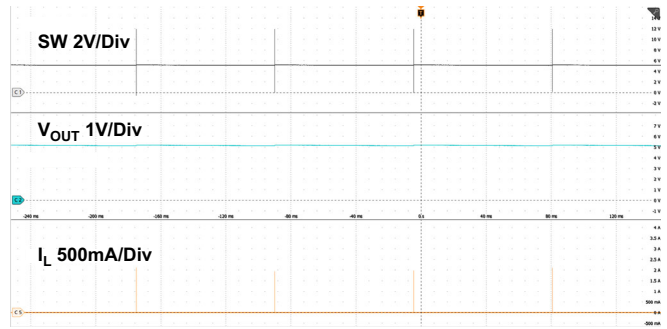

Figure 11. Steady-State Operation,  $I_{OUT} = 0\text{A}$   
( $V_{OUT} = 5\text{V}$ )

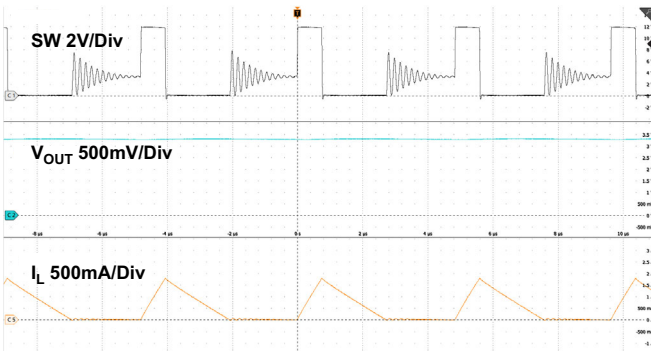

Figure 12. Steady-State Operation,  $I_{OUT} = 1\text{A}$   
( $V_{OUT} = 3.3\text{V}$ )

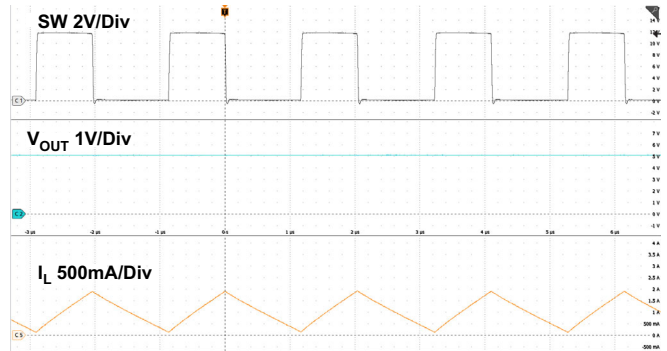

Figure 13. Steady-State Operation,  $I_{OUT} = 1\text{A}$   
( $V_{OUT} = 5\text{V}$ )

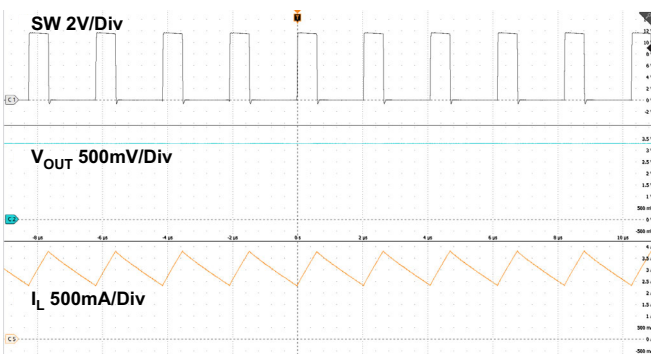

Figure 14. Steady-State Operation,  $I_{OUT} = 3\text{A}$   
( $V_{OUT} = 3.3\text{V}$ )

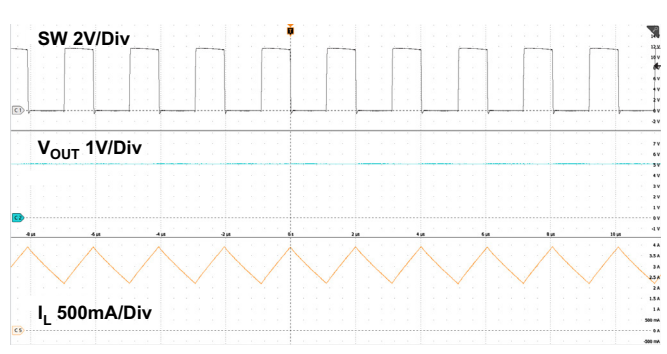

Figure 15. Steady-State Operation,  $I_{OUT} = 3\text{A}$   
( $V_{OUT} = 5\text{V}$ )

Typical Values are at  $T_A = +25^\circ\text{C}$ ,  $V_{IN} = 12\text{V}$ ,  $V_{OUT} = 3.3\text{V}$ ,  $I_{OUT} = 3\text{A}$ ,  $L = 3.3\mu\text{H}$ , unless otherwise noted. (Cont.)

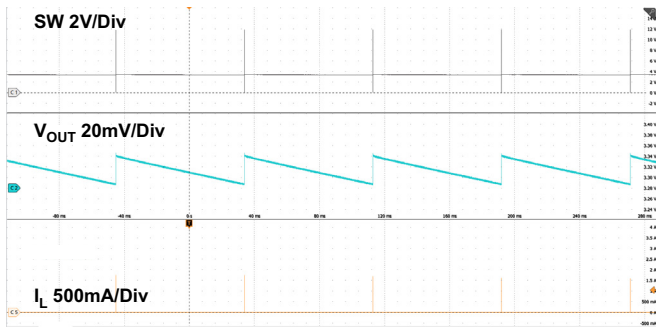

Figure 16.  $V_{OUT}$  Ripple at  $I_{OUT} = 0\text{A}$  ( $V_{OUT} = 3.3\text{V}$ )

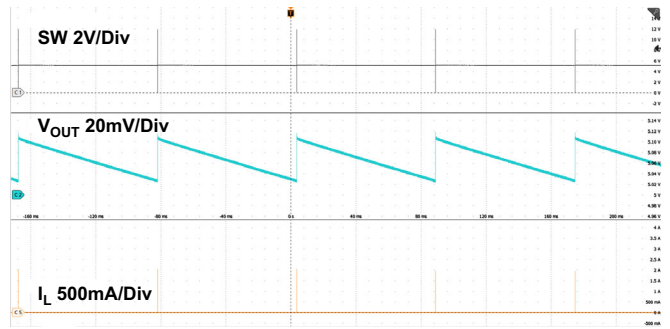

Figure 17.  $V_{OUT}$  Ripple at  $I_{OUT} = 0\text{A}$  ( $V_{OUT} = 5\text{V}$ )

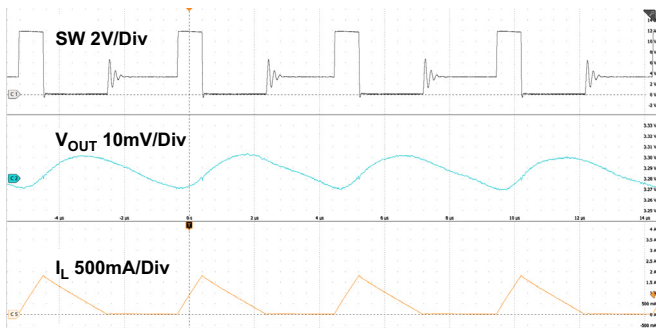

Figure 18.  $V_{OUT}$  Ripple at  $I_{OUT} = 1\text{A}$  ( $V_{OUT} = 3.3\text{V}$ )

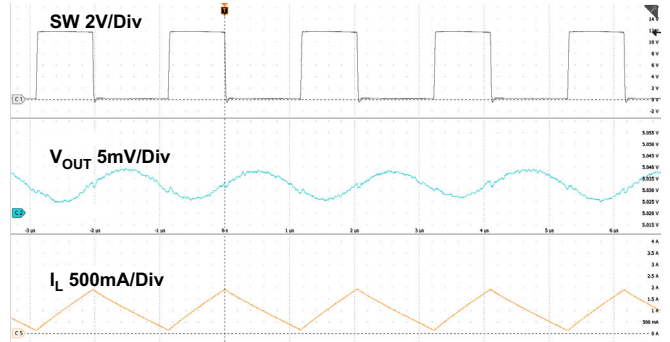

Figure 19.  $V_{OUT}$  Ripple at  $I_{OUT} = 1\text{A}$  ( $V_{OUT} = 5\text{V}$ )

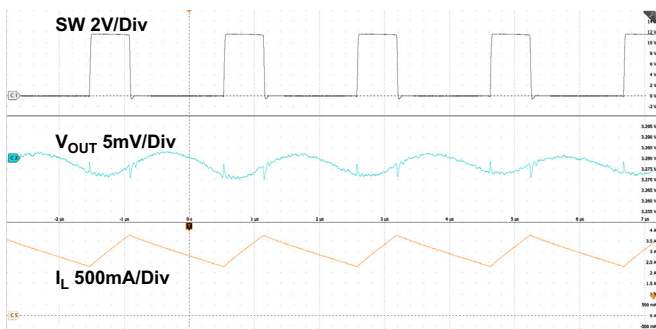

Figure 20.  $V_{OUT}$  Ripple at  $I_{OUT} = 3\text{A}$  ( $V_{OUT} = 3.3\text{V}$ )

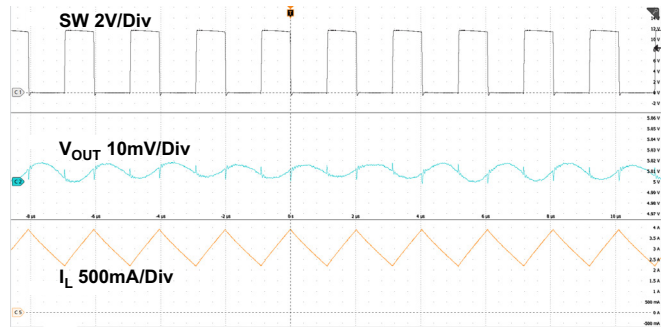

Figure 21.  $V_{OUT}$  Ripple at  $I_{OUT} = 3\text{A}$  ( $V_{OUT} = 5\text{V}$ )

Typical Values are at  $T_A = +25^\circ\text{C}$ ,  $V_{IN} = 12\text{V}$ ,  $V_{OUT} = 3.3\text{V}$ ,  $I_{OUT} = 3\text{A}$ ,  $L = 3.3\mu\text{H}$ , unless otherwise noted. (Cont.)

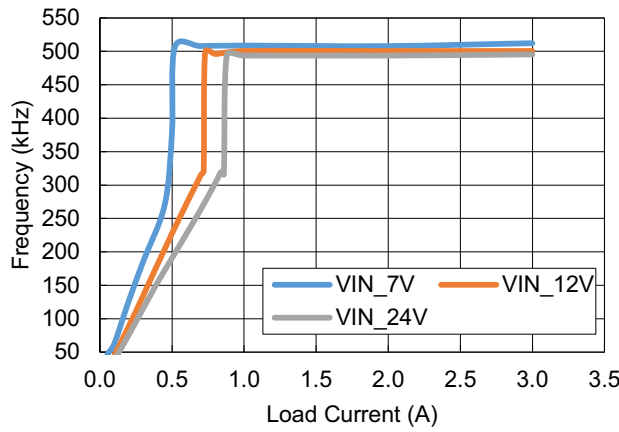

Figure 22. Switching Frequency vs Load Current

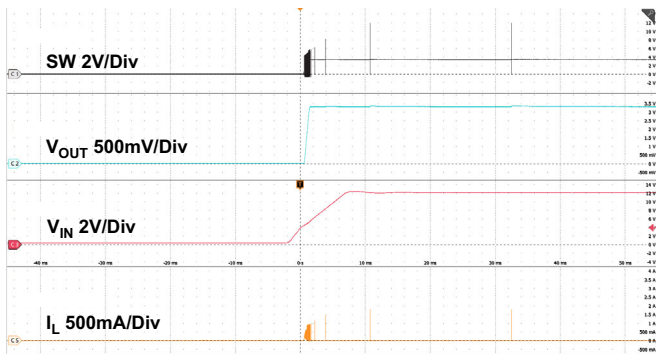

Figure 23. Startup through  $V_{IN}$  ( $I_{OUT} = 0\text{A}$ )

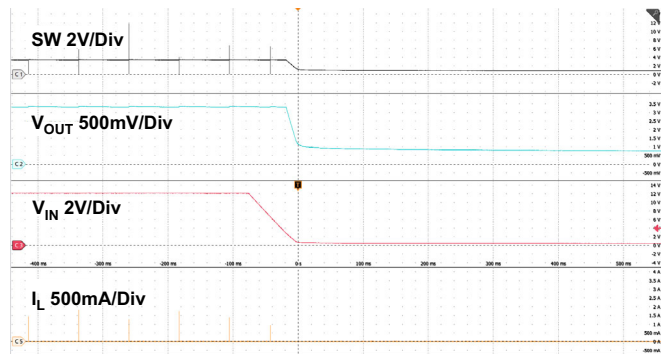

Figure 24. Shutdown through  $V_{IN}$  ( $I_{OUT} = 0\text{A}$ )

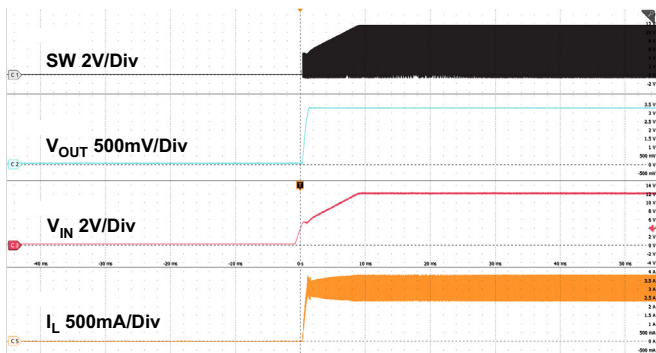

Figure 25. Startup through  $V_{IN}$  ( $I_{OUT} = 3\text{A}$ )

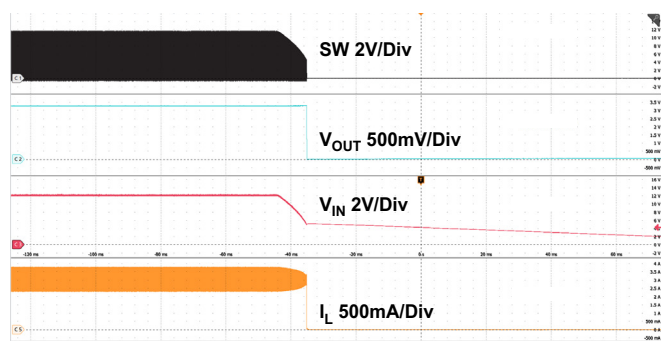

Figure 26. Shutdown through  $V_{IN}$  ( $I_{OUT} = 3\text{A}$ )

Typical Values are at  $T_A = +25^\circ\text{C}$ ,  $V_{IN} = 12\text{V}$ ,  $V_{OUT} = 3.3\text{V}$ ,  $I_{OUT} = 3\text{A}$ ,  $L = 3.3\mu\text{H}$ , unless otherwise noted. (Cont.)

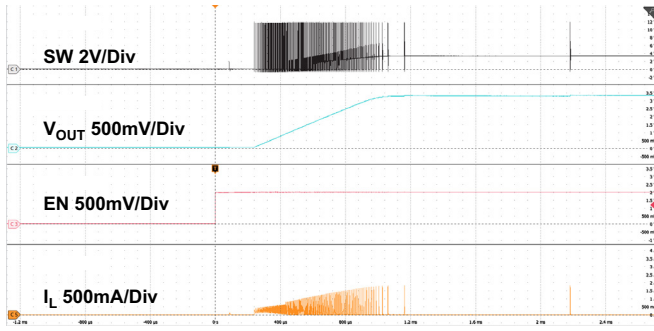

Figure 27. Startup through EN ( $I_{OUT} = 0\text{A}$ )

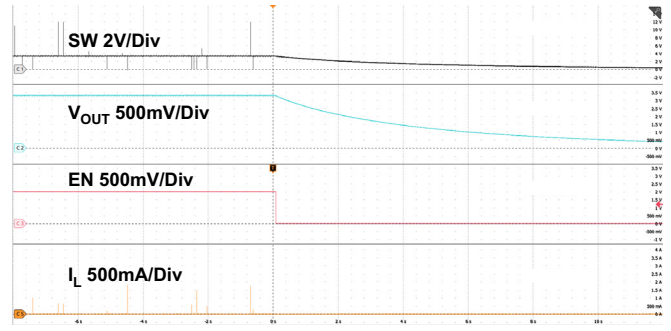

Figure 28. Shutdown through EN ( $I_{OUT} = 0\text{A}$ )

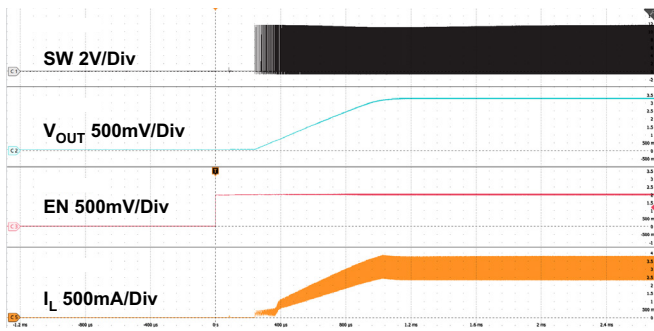

Figure 29. Startup through EN ( $I_{OUT} = 3\text{A}$ )

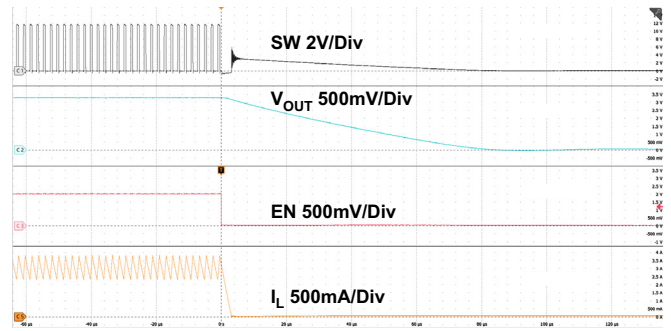

Figure 30. Shutdown through EN ( $I_{OUT} = 3\text{A}$ )

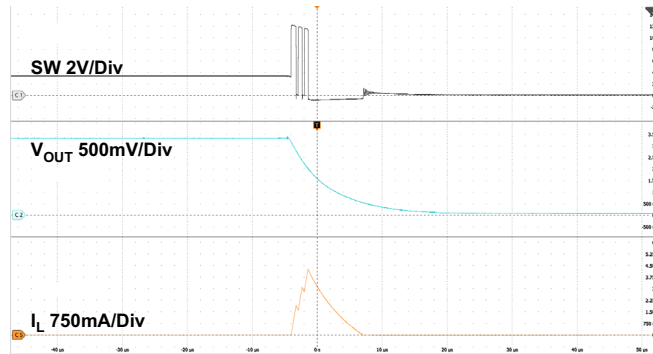

Figure 31.  $I_{OUT} = 0\text{A}$  to Short-Circuit

Typical Values are at  $T_A = +25^\circ\text{C}$ ,  $V_{IN} = 12\text{V}$ ,  $V_{OUT} = 3.3\text{V}$ ,  $I_{OUT} = 3\text{A}$ ,  $L = 3.3\mu\text{H}$ , unless otherwise noted. (Cont.)

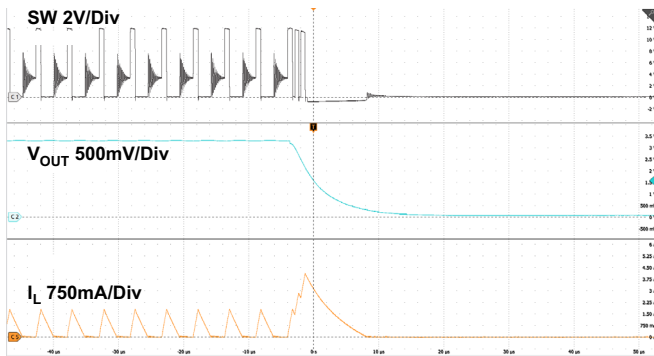

Figure 32.  $I_{OUT} = 1\text{A}$  to Short-Circuit

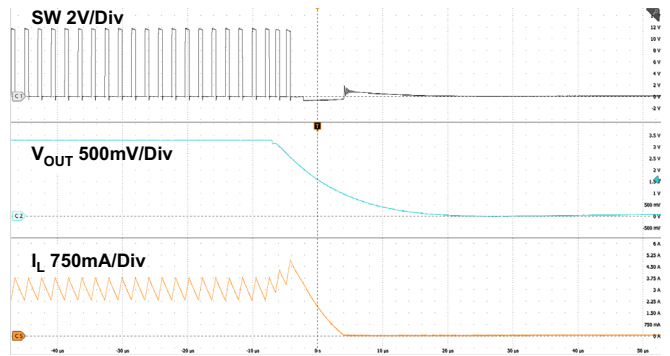

Figure 33.  $I_{OUT} = 3\text{A}$  to Short-Circuit

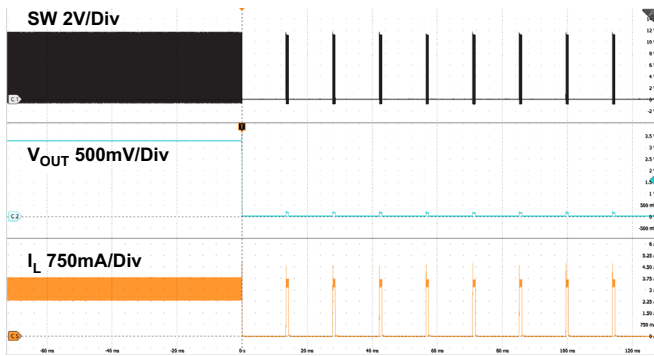

Figure 34. Hiccup after Output Short-Circuit

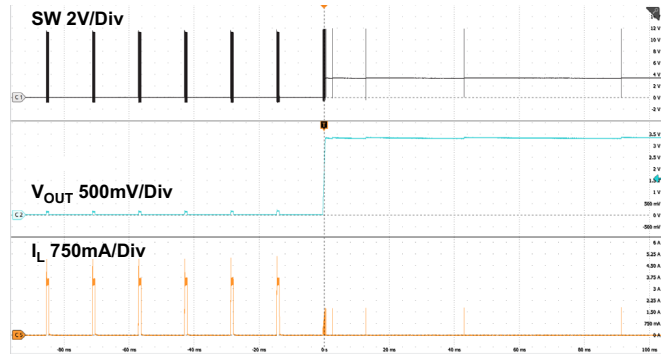

Figure 35. Short-Circuit to 0A Recovery

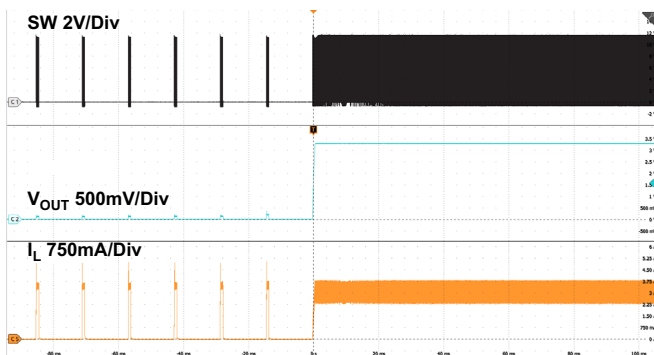

Figure 36. Short-Circuit to 3A Recovery

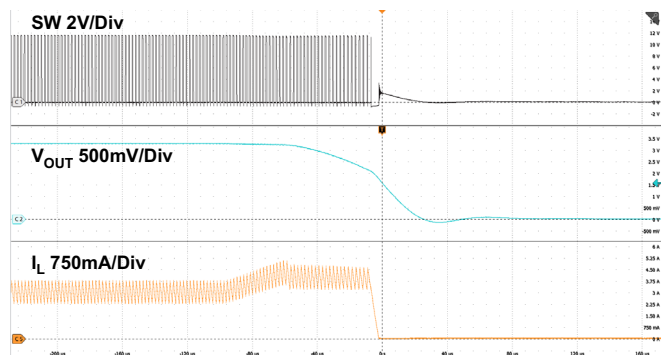

Figure 37. Low-Side Overcurrent (LSOC) Protection

Typical Values are at  $T_A = +25^\circ\text{C}$ ,  $V_{IN} = 12\text{V}$ ,  $V_{OUT} = 3.3\text{V}$ ,  $I_{OUT} = 3\text{A}$ ,  $L = 3.3\mu\text{H}$ , unless otherwise noted. (Cont.)

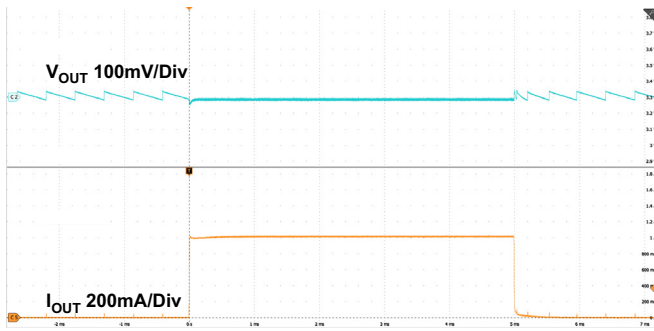

Figure 38. Load Transient, 0A to 1A (0.5A/ $\mu\text{s}$ )

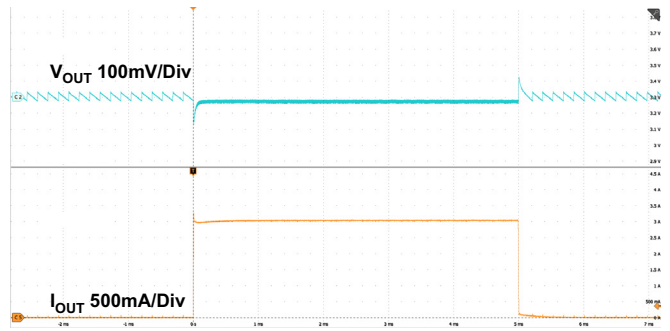

Figure 39. Load Transient, 0A to 3A (0.5A/ $\mu\text{s}$ )

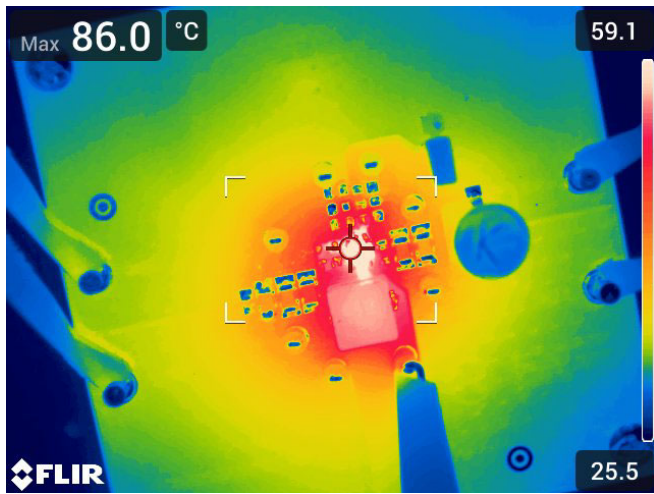

Figure 40.  $12\text{V}_{IN}$ ,  $3.3\text{V}_{OUT}$ , 3A load,  
IC Temperature =  $86^\circ\text{C}$ ,  
Max Ambient Temperature =  $62^\circ\text{C}$

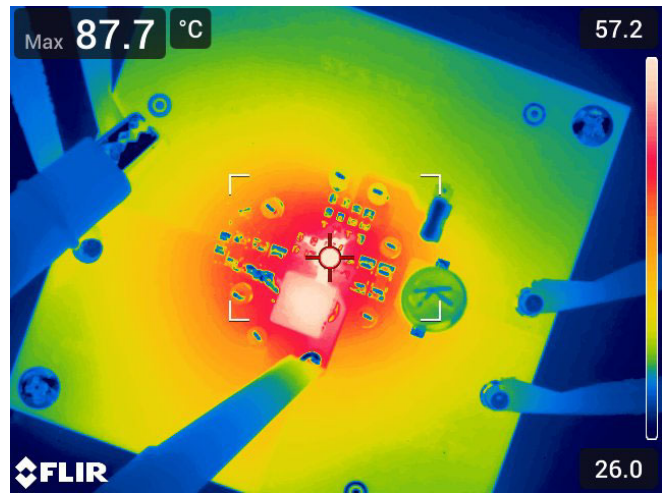

Figure 41.  $12\text{V}_{IN}$ ,  $5\text{V}_{OUT}$ , 3A load,  
IC Temperature =  $87.7^\circ\text{C}$ ,  
Max Ambient Temperature =  $60.3^\circ\text{C}$

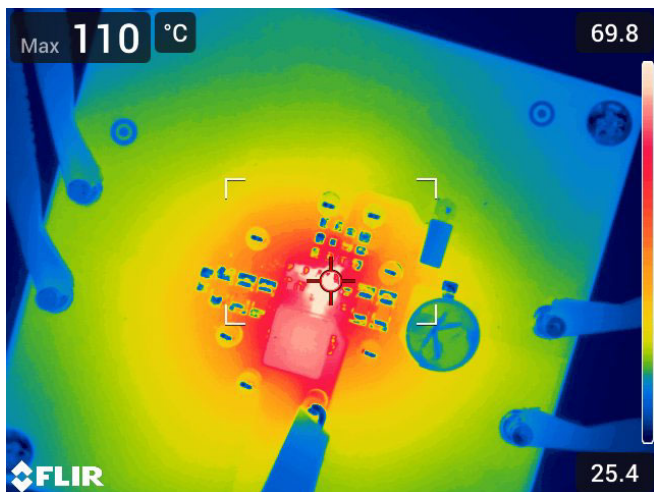

Figure 42.  $24\text{V}_{IN}$ ,  $3.3\text{V}_{OUT}$ , 3A load,  
IC Temperature =  $110^\circ\text{C}$ ,  
Max Ambient Temperature =  $38^\circ\text{C}$

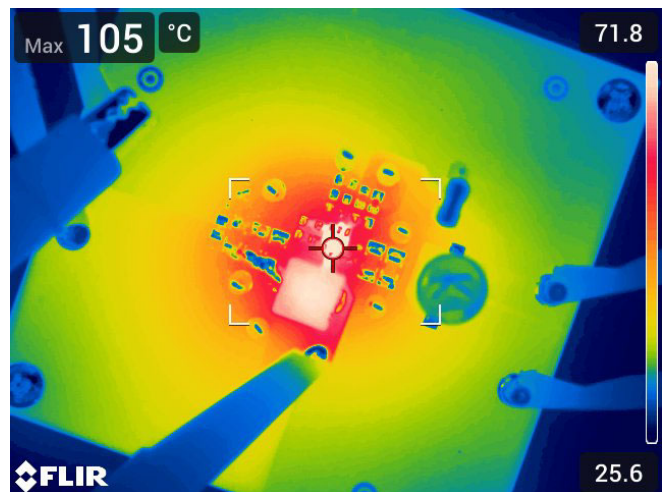

Figure 43.  $24\text{V}_{IN}$ ,  $5\text{V}_{OUT}$ , 3A load,  
IC Temperature =  $105^\circ\text{C}$ ,  
Max Ambient Temperature =  $43^\circ\text{C}$

## 5. Faults and Fault Handling Description

### 5.1 System Level Fault Summary

Top level faults ( $V_{IN}$  UVLO, OTP) disable  $V_{OUT}$  and the IC enters the POR state until the fault is cleared. The device then resumes normal operation according to the state of the EN pin.

Fault Type	Detection Activated When	Detection Delay	Circuit behavior
$V_{IN}$ UVLO Falling	EN is higher than threshold.	2 $\mu$ s	POR (Power on Reset), chip restarts from initial reset state when UVLO is satisfied.
Over-temperature (OT) Shutdown	After EN pin goes high and IC is in active state.	Immediate	POR using internal regulator, hiccup timer is engaged.
$V_{OUT}$ Undervoltage (UV)	After soft-start done, after Hiccup on-time.	Immediate	After Soft-start is done (0.8ms), if $V_{OUT}$ falls to 65% of set value and LSOC limit is reached, hiccup timer is engaged.
Low-Side Overcurrent (LSOC) Limit	Start of buck regulator switching.	Immediate	If LSOC is detected, the device keeps LS FET on until current falls below LSOC limit.

## 6. Functional Description

The RAA211230 is an integrated synchronous buck regulator with current mode constant on-time (COT) control. It can operate across a wide input voltage range from 4.5V to 24V and deliver load current up to 3A across the -40°C to 125°C temperature range. The output voltage is sensed on the FB pin through external feedback resistors and compared with the internal reference of 0.765V to produce the control signal, which decides when to turn on the high-side FET. The internal COT circuit determines the on-time of the high-side FET based on the sensed value of  $V_{IN}$  and  $V_{OUT}$ .

At light load conditions, the regulator operates in DCM mode with a switching frequency determined by the output load (pulse-frequency modulation). At higher loads, the part transitions to CCM mode with constant frequency of 500kHz (see [Figure 22](#)).

### 6.1 Soft-Start

Soft-start forces the regulator to ramp up in a controlled fashion, which prevents high inrush current or output voltage overshoot at startup (see [Figure 29](#)). During soft-start, the reference voltage input of the error amplifier ramps up from 0V to its nominal value of 0.765V in 0.8ms.

### 6.2 Undervoltage Lockout

The regulator has an undervoltage lockout (UVLO) on the  $V_{IN}$  pin that prevents the regulator from starting up until the input voltage exceeds 4.3V (typical). The UVLO threshold has approximately 425mV of hysteresis; therefore, the device continues to operate when  $V_{IN}$  decreases until it drops below 3.875V (typical). Hysteresis prevents the part from turning off during power-up if the  $V_{IN}$  is non-monotonic. Renesas recommends ensuring that the current path length from the  $V_{IN}$  power supply or upstream regulator to the IC is as small as possible to prevent jittering during  $V_{IN}$  turn-off and turn-on.

### 6.3 Enable Control

RAA211230 has an enable pin that turns the device on when pulled high. When EN is low, the IC goes into shutdown mode (see [Figure 27](#) to [Figure 30](#)). RAA211230 has an EN rising threshold voltage of 1.3V (typical). EN threshold hysteresis is 100mV (typical). RAA211230 also has an Enable shutdown threshold of 0.7V; below the threshold, all the internal circuitry of the IC shuts down.

The EN pin can be tied directly to VIN for always-on operation. The device has an accurate Enable threshold that allows you to program the V<sub>IN</sub> UVLO threshold by connecting VIN to EN using a resistor divider. The UVLO can be set with the resistor divider based on Equation 1 where V<sub>INR</sub> is the rising threshold of V<sub>IN</sub> UVLO (see Figure 2).

$$(EQ. 1) \quad \frac{R_{EN1}}{R_{EN2}} = \left( \frac{V_{INR} - 1.3}{1.3} \right)$$

The resulting input voltage for the part to be turned off is calculated using Equation 2:

$$(EQ. 2) \quad V_{INF} = 1.2X \frac{R_{EN1} + R_{EN2}}{R_{EN2}}$$

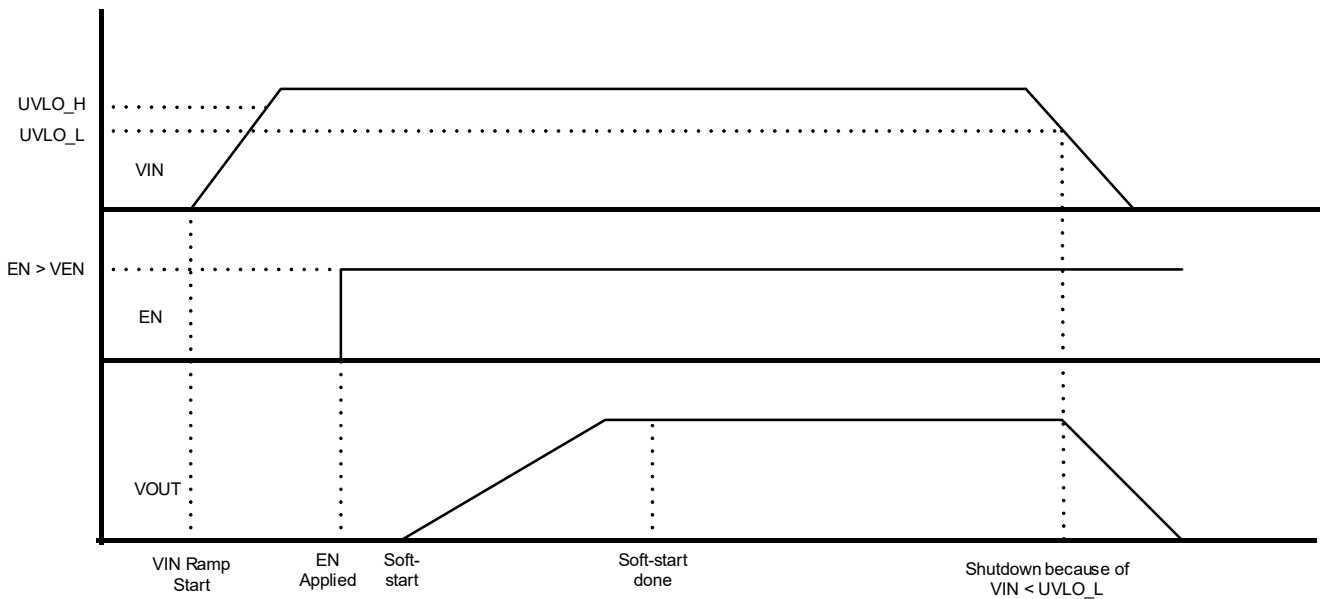

Figure 44. Timing Diagram with EN Turn On and VIN UVLO Turn Off

### 6.4 Overcurrent Protection (OCP) and V<sub>OUT</sub> Undervoltage Protection

RAA211230 has a low-side overcurrent (LSOC) protection feature. After the regulator starts up, if the current through the internal low-side MOSFET exceeds the current limit, the device skips the high-side cycles until the LSOC condition clears.

RAA211230 also has a V<sub>OUT</sub> undervoltage (UV) protection. The internal undervoltage comparator compares the FB pin voltage to 65% of the reference voltage. When LSOC is detected and this voltage drops below 65% of nominal (because of a drop in V<sub>OUT</sub> to below 65% of its set point), the regulator stops switching and engages Hiccup mode operation at an interval of 13ms (see Figure 34).

### 6.5 Over-Temperature Protection

Over-temperature protection (OTP) limits the maximum junction temperature in the RAA211230. This limits total power dissipation by shutting off the regulator when the IC junction temperature exceeds 170°C (typical). There is a 40°C hysteresis for OTP. After the junction temperature drops below 130°C, the RAA211230 resumes operation by stepping through soft-start.



## 7. Applications Information

The recommended component selections for typical applications are listed in [Table 2](#).

**Table 2. Recommended Components Selection for Typical Application**

V <sub>IN</sub> (V)	V <sub>OUT</sub> (V)	R <sub>FB1</sub> (kΩ)	R <sub>FB2</sub> (kΩ)	L(μH)	C <sub>OUT</sub> (μF)
12	1.8	13.7	10	2.2	68
12	3.3	33.2	10	3.3	37
12	5	54.9	10	4.3	25
12	8	95.3	10	4.7	15
5	1.05	3.74	10	1.5	122
5	1.8	13.7	10	2	68
5	3.3	33.2	10	1.8	37
24	1.8	13.7	10	3	68
24	3.3	33.2	10	4.3	37
24	5	54.9	10	5.6	25
24	12	147	10	8.7	10

### 7.1 Output Voltage Feedback Resistor Divider

The output voltage can be programmed down to 0.765V with a resistor divider from V<sub>OUT</sub> to the FB pin to GND based on [Equation 3](#). The recommended R<sub>FB2</sub> (see [Figure 1](#)) resistance is 10kΩ. See [Table 2](#) for R<sub>FB1</sub> and R<sub>FB2</sub> values for typical V<sub>OUT</sub> applications.

$$(EQ. 3) \quad R_{FB1} = R_{FB2} \times \frac{V_{OUT} - 0.765}{0.765}$$

High-impedance nodes are more prone to pickup noise. The recommended range of feedback resistors (R<sub>FB1</sub> + R<sub>FB2</sub>) is 5kΩ to 150kΩ.

Analog circuitry in the Boot regulator outputs 40μA at the SW node. For applications using a zero-load condition, this 40μA must be consumed by the feedback resistors to prevent positive drift of V<sub>OUT</sub>. Renesas recommends the following maximum impedance (R<sub>FB1</sub> + R<sub>FB2</sub>)<sub>max</sub> for applications using zero-load condition, where R<sub>FB1</sub> and R<sub>FB2</sub> are in kΩ:

$$(EQ. 4) \quad (R_{FB1} + R_{FB2})_{max} = 0.8 \times \frac{V_{OUT}}{40} \times 10^3$$

The absolute maximum output voltage for RAA211230 is 14V. [Equation 5](#) calculates the maximum operating output voltage for a given input voltage when the max V<sub>OUT</sub> is less than 14V. Renesas recommends to leave some margin for max V<sub>OUT</sub> calculated in [Equation 5](#) to account for losses in the circuit. [Figure 45](#) shows the operating V<sub>OUT</sub> range across V<sub>IN</sub>.

$$(EQ. 5) \quad V_{OUTmax} = \frac{V_{IN}}{f_{SW}} \times \left( \frac{1}{f_{SW}} - t_{OFFmin} \right)$$

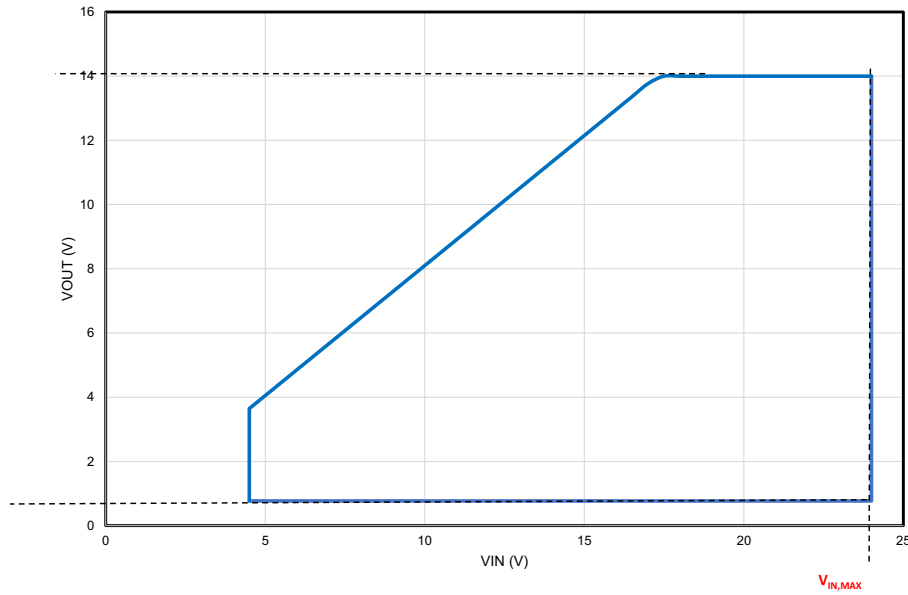

Figure 45. Operating Range for  $V_{IN}$  and  $V_{OUT}$

## 7.2 Inductor Selection

To minimize power losses, select an inductor with the lowest possible DC resistance (DCR). The saturation current rating of the inductor should be high enough to accommodate the DC load current and AC ripple current with an additional margin for overload conditions. The inductor of the buck converter determines its ripple current so that it also determines its output ripple voltage. Selecting a higher inductance value results in lower output ripple voltage, but it may increase the response time and output voltage drop during a load transient. The ripple voltage and current are approximated by Equation 6 and Equation 7:

$$(EQ. 6) \quad \Delta I = \frac{V_{IN} - V_{OUT}}{F_{sw} \times L} \times \frac{V_{OUT}}{V_{IN}}$$

$$(EQ. 7) \quad \Delta V_{OUT} = \Delta I \times ESR$$

A reasonable starting point for the inductor ripple current is 20% to 50% of the maximum output current. Table 2 can be referenced for selecting the inductor value for typical  $V_{OUT}$  applications.

During overcurrent and short-circuit conditions, the peak inductor current becomes higher than the current during normal operation. Renesas recommends using inductors with soft saturation characteristics.

## 7.3 Input Capacitor Selection

The input capacitor in a buck converter maintains the input voltage by suppressing the voltage ripple induced by discontinuous switching current. The required RMS current rating  $I_{IN(RMS)}$  of the input capacitor can be approximated using Equation 8, where  $I_{OUT(MAX)}$  is the maximum average load current and D is the duty ratio:

$$(EQ. 8) \quad I_{IN(RMS)} = I_{OUT(MAX)} \times \sqrt{D \times (1 - D)}$$

When D equals 0.5,  $I_{IN(RMS)}$  has the highest value and that value is  $I_{OUT(MAX)}/2$ .

The voltage rating of the input capacitor should be higher than the maximum input voltage. The required capacitance  $C_{IN}$  of the input capacitor to ensure the expected peak-to-peak input voltage ripple  $\Delta V_{IN}$  is calculated using Equation 9 where  $F_{SW}$  is the switching frequency.

$$(EQ. 9) \quad C_{IN} = I_{OUT(MAX)} \times \frac{D \times (1-D)}{F_{sw} \times \Delta V_{IN}}$$

The required capacitance also has the maximum value when D equals 0.5.

Renesas recommends using low ESR/low ESL ceramic capacitors across the input of the regulator. When selecting the ceramic capacitors for power supply applications, consider that the effective capacitance reduces with DC bias voltage across it. You need to consult the capacitor datasheet to understand the impact of this effect. Renesas also recommends using X5R/X7R dielectric ceramic capacitors because of their small temperature coefficient.

If the input to the regulator is fed through a high-impedance path, Renesas recommends adding an electrolytic capacitor in addition to the ceramic capacitor to dampen the input voltage oscillation effects.

## 7.4 Output Capacitor Selection

Output capacitor selection impacts the steady state and transient performance of the buck converter. Factors such as output ripple voltage, output voltage excursion during transients, and control loop stability should be considered when selecting the output capacitor. Renesas recommends using X5R/X7R dielectric ceramic for the output capacitor. When selecting the ceramic capacitor, consider that the effective capacitance reduces with a DC bias voltage across it.

Use the effective capacitance of the ceramic capacitor when determining the output voltage ripple. The required capacitance  $C_{OUT(RIPPLE)}$  is calculated using Equation 10, where  $\Delta I_L$  is the inductor peak-to-peak current ripple and  $f_{sw}$  is the switching frequency:

$$(EQ. 10) \quad C_{OUT(RIPPLE)} = \frac{\Delta I_L}{8 \times f_{sw} \times \Delta V_{OUT(RIPPLE)}}$$

To meet the output voltage variation requirements during load step-up and load step-down transients, the required capacitance  $C_{OUT(STEPUP)}$  is calculated using Equation 11 and  $C_{OUT(STEPDOWN)}$  is calculated using Equation 12, where  $I_{STEP}$  is the transient load step and  $\Delta V_{OUT}$  is the expected voltage variation during the transient:

$$(EQ. 11) \quad C_{OUT(STEPUP)} = \frac{L \times \left( I_{STEP} + \frac{\Delta I_L}{2} \right)^2}{2 \times (V_{IN} - V_{OUT}) \times \Delta V_{OUT}}$$

$$(EQ. 12) \quad C_{OUT(STEPDOWN)} = \frac{L \times \left( I_{STEP} + \frac{\Delta I_L}{2} \right)^2}{2 \times V_{OUT} \times \Delta V_{OUT}}$$

To have a stable control loop with adequate gain margin, phase margin, and bandwidth, the required capacitance  $C_{OUT(LOOP)}$  is derived using Equation 13, where  $C_{OUT(LOOP)}$  is in  $\mu F$  and  $V_{OUT}$  is in V:

$$(EQ. 13) \quad C_{OUT(LOOP)}(\mu F) = \frac{121.7}{V_{OUT}}$$

The output capacitors should be selected so that previous requirements are met: this means that the total capacitance should be greater than the highest value calculated in [Equation 10](#), [Equation 11](#), [Equation 12](#), or [Equation 13](#).

See [Table 2](#) for recommended values of output capacitor for typical  $V_{OUT}$  applications.

## 7.5 BOOT Refresh and Capacitor Selection

Approximately 85 $\mu$ s after EN is driven high and before the start-up process begins, the RAA211230 turns on the internal BOOT voltage regulator. This action charges the boot capacitor before the start-up process begins. The BOOT UVLO function is provided to prevent turn-on of HS FET at low BOOT Voltages. When the BOOT voltage is below 2.5V, the regulator skips the HS pulse and provides an LS pulse until the BOOT voltage rises above 2.5V.

A capacitor is needed between the BST and SW pins to provide gate voltage for the high-side internal MOSFET. Renesas recommends using a greater than 10V X5R/X7R 0.1 $\mu$ F ceramic capacitor as the bootstrap capacitor for most applications.

## 8. Component Placement and Layout Suggestions

The printed circuit board (PCB) layout is critical for properly operating the RAA211230. The following guidelines are recommended to achieve good performance.

- Use a combination of a bulk capacitor and smaller ceramic capacitors with low ESL for input capacitors and place them as close as possible to the IC. Place the input ceramic capacitor(s) as close as possible to the IC.
- Keep the power loop (input ceramic capacitor, IC VIN, and PGND pins) as small as possible to minimize switch node voltage ringing caused by parasitic inductance in the PCB traces. Minimizing loop size also results in better EMI performance.
- Place bootstrap capacitors close to the IC between BST and SW pins on the same side of the PCB as the IC. Renesas recommends using a 0.1μF ceramic capacitor.
- Keep the phase node copper area small to reduce the parasitic capacitance but large enough to handle the load current. Place the inductor close to the regulator.
- Route the output voltage feedback signal away from SW and BST. Place feedback resistors close to the FB pin of the regulator.
- Place an output capacitor close to the inductor.

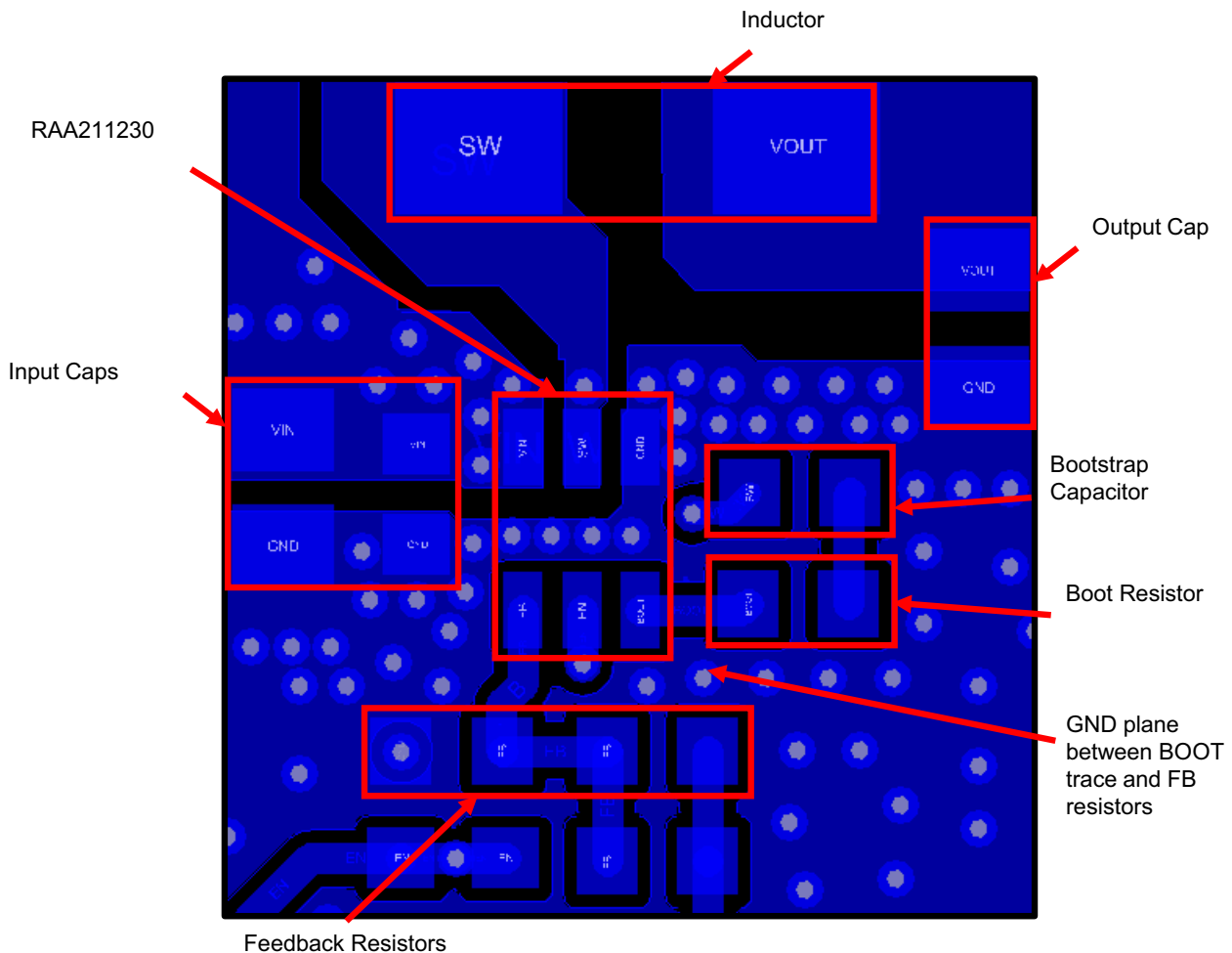

Figure 46. Example Layout for RAA211230

## 9. Package Outline Drawing

For the most recent package outline drawing, see [P6.064C](#).

P6.064C

6 Lead Thin Small Outline Transistor (TSOT) Plastic Package  
Rev 2, 12/20

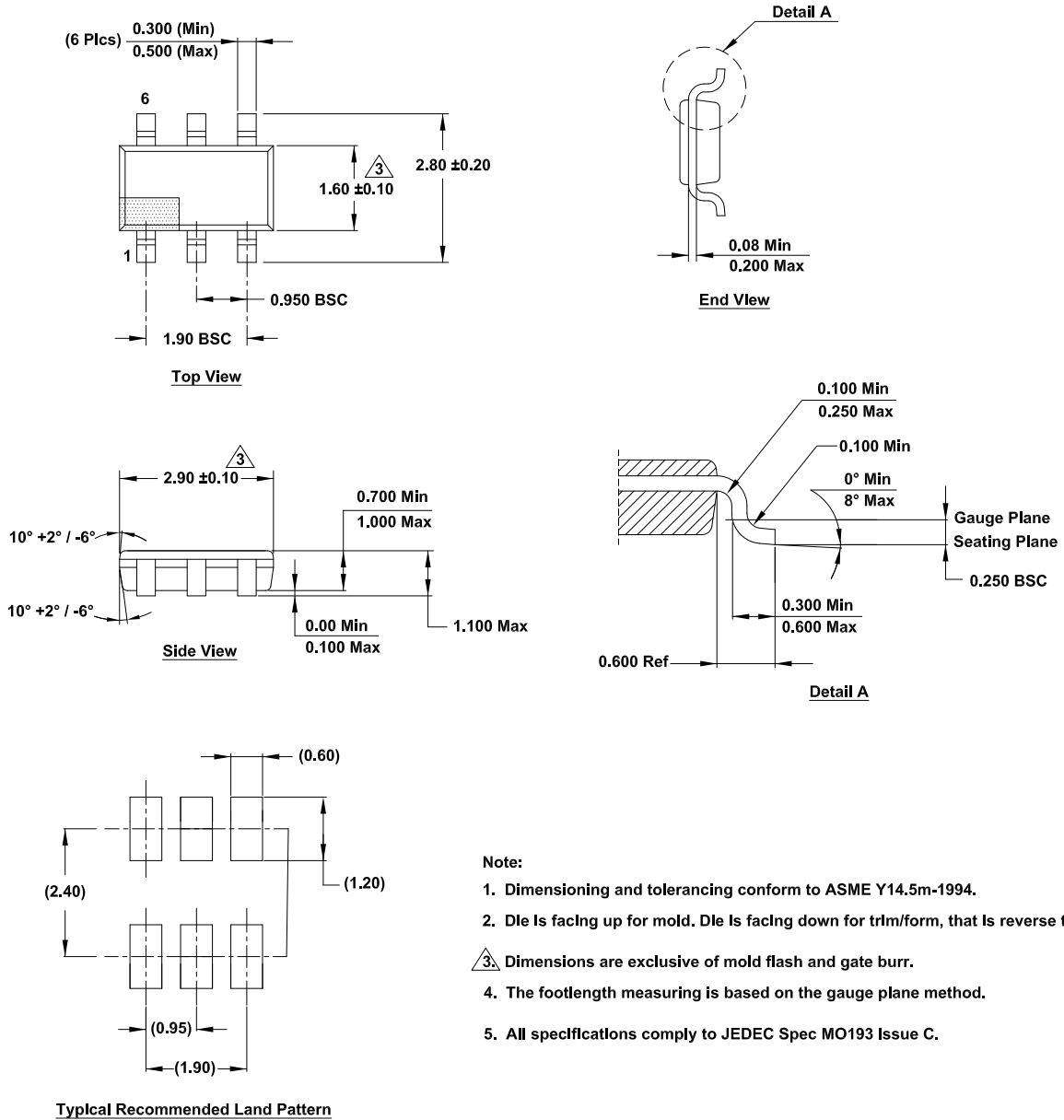

## 10. Ordering Information

Part Number <sup>[1][2]</sup>	Part Marking <sup>[3]</sup>	Package Description <sup>[4]</sup> (RoHS Compliant)	Pkg. Dwg. #	Carrier Type <sup>[5]</sup>	Temp Range
RAA2112304GP3#JA0	230	6Ld TSOT-23	<a href="#">P6.064C</a>	Reel, 3k	-40 to +125°C
RTKA211230DE0020BU	Evaluation Board				

1. These Pb-free plastic packaged products employ special Pb-free material sets, molding compounds/die attach materials, and 100% matte tin plate plus anneal (e3 termination finish, which is RoHS compliant and compatible with both SnPb and Pb-free soldering operations). Pb-free products are MSL classified at Pb-free peak reflow temperatures that meet or exceed the Pb-free requirements of IPC/JEDEC J-STD-020.
2. For Moisture Sensitivity Level (MSL), see the [RAA211230](#) device page. For more information about MSL, see [TB363](#).
3. The part marking is located on the bottom of the part.
4. For the Pb-Free Reflow Profile, see [TB493](#).
5. See [TB347](#) for details about reel specifications.

## 11. Revision History

Revision	Date	Description
1.02	Oct 17, 2023	Changed the typical value to 3.875V in the Undervoltage Lockout section.
1.01	Jul 11, 2023	Corrected the description for Item 3 in Table 1. Updated the values for the Human Body Model and Charged Device Model in the Absolute Maximum Ratings.
1.00	Jun 21, 2023	Initial release.

## IMPORTANT NOTICE AND DISCLAIMER

RENESAS ELECTRONICS CORPORATION AND ITS SUBSIDIARIES (“RENESAS”) PROVIDES TECHNICAL SPECIFICATIONS AND RELIABILITY DATA (INCLUDING DATASHEETS), DESIGN RESOURCES (INCLUDING REFERENCE DESIGNS), APPLICATION OR OTHER DESIGN ADVICE, WEB TOOLS, SAFETY INFORMATION, AND OTHER RESOURCES “AS IS” AND WITH ALL FAULTS, AND DISCLAIMS ALL WARRANTIES, EXPRESS OR IMPLIED, INCLUDING, WITHOUT LIMITATION, ANY IMPLIED WARRANTIES OF MERCHANTABILITY, FITNESS FOR A PARTICULAR PURPOSE, OR NON-INFRINGEMENT OF THIRD PARTY INTELLECTUAL PROPERTY RIGHTS.

These resources are intended for developers skilled in the art designing with Renesas products. You are solely responsible for (1) selecting the appropriate products for your application, (2) designing, validating, and testing your application, and (3) ensuring your application meets applicable standards, and any other safety, security, or other requirements. These resources are subject to change without notice. Renesas grants you permission to use these resources only for development of an application that uses Renesas products. Other reproduction or use of these resources is strictly prohibited. No license is granted to any other Renesas intellectual property or to any third party intellectual property. Renesas disclaims responsibility for, and you will fully indemnify Renesas and its representatives against, any claims, damages, costs, losses, or liabilities arising out of your use of these resources. Renesas' products are provided only subject to Renesas' Terms and Conditions of Sale or other applicable terms agreed to in writing. No use of any Renesas resources expands or otherwise alters any applicable warranties or warranty disclaimers for these products.

(Disclaimer Rev.1.0 Mar 2020)

### Corporate Headquarters

TOYOSU FORESIA, 3-2-24 Toyosu,  
Koto-ku, Tokyo 135-0061, Japan  
[www.renesas.com](http://www.renesas.com)

### Contact Information

For further information on a product, technology, the most up-to-date version of a document, or your nearest sales office, please visit:  
[www.renesas.com/contact/](http://www.renesas.com/contact/)

### Trademarks

Renesas and the Renesas logo are trademarks of Renesas Electronics Corporation. All trademarks and registered trademarks are the property of their respective owners.