

SLG46827-A

Auto AEC-Q100 Qualified GreenPAK Programmable Mixed-Signal Matrix with In-System Debug

General Description

The SLG46827-A provides a small, low power component for commonly used Mixed-Signal functions. The user creates the circuit design by programming the multiple time Non-Volatile Memory (NVM) to configure the interconnect logic, the IOs, and the macrocells of the SLG46827-A. Dual power supply allows to flexibly interface two independent voltage domains. This highly versatile device allows a wide variety of Mixed-Signal functions to be designed within a very small, low power single integrated circuit.

Key Features

- Two High Speed General Purpose Rail-to-Rail Analog Comparators (ACMPxH)
- Two Low Power General Purpose Rail-to-Rail Analog Comparators (ACMPxL)
- Two Voltage References
 - Two Vref Outputs
- Eleven Combination Function Macrocells
 - Three Selectable DFF/LATCH or 2-bit LUTs
 - One Selectable Programmable Pattern Generator or 2-bit LUT
 - Six Selectable DFF/LATCH or 3-bit LUTs
 - One Selectable Pipe Delay or Ripple Counter, or 3-bit LUT
- Eight Multi-Function Macrocells
 - Seven Selectable DFF/LATCH or 3-bit LUTs + 8-bit Delay/Counters
 - One Selectable DFF/LATCH or 4-bit LUT + 16-bit Delay/Counter
- Serial Communications
 - I²C Protocol Interface
- Programmable Delay with Edge Detector Output
- Deglitch Filter or Edge Detector
- Three Oscillators
 - 2.048 kHz Oscillator
 - 2.048 MHz Oscillator
 - 25 MHz Oscillator
- Analog Temperature Sensor
- Power-On Reset
- In-System Debug
- Multiple Time Programmable Memory in Development
- Wide Range Power Supply
 - 2.5 V (±8 %) to 5 V (±10 %) V_{DD}
 - 1.8 V (±5 %) to 5 V (±10 %) V_{DD2} (V_{DD2} ≤ V_{DD})
- Ambient Operating Temperature Range: -40 °C to +105 °C
- RoHS Compliant/Halogen-Free
- Packages Available
 - 20-pin TSSOP: 6.5 mm x 6.4 mm x 1.2 mm, 0.65 mm pitch
- AEC-Q100 (T_A = -40°C to 105°C) Qualified

Applications

- Car Navigation and Telematics
- In-Car Infotainment/Dashboard
- Automotive Display Clusters
- Advanced Driver Assistance Systems (ADAS)

SLG46827-A

Auto AEC-Q100 Qualified GreenPAK Programmable Mixed-Signal Matrix with In-System Debug

Contents

General Description	1
Key Features	1
Applications	1
1 Block Diagram	7
2 Pinout	8
2.1 Pin Configuration - TSSOP-20L	8
3 Characteristics	12
3.1 Absolute Maximum Ratings	12
3.2 Electrostatic Discharge Ratings	12
3.3 Recommended Operating Conditions	12
3.4 Electrical Characteristics	13
3.5 Timing Characteristics	21
3.6 OSC Characteristics	26
3.7 ACMP Specifications	26
3.8 Analog Temperature Sensor Characteristics	30
4 In-System Debug	32
5 IO Pins	33
5.1 IO Pins	33
5.2 GPIO Pins	33
5.3 GPO Pins	33
5.4 GPI Pins	33
5.5 Pull-Up/Down Resistors	33
5.6 Fast Pull-up/down during Power-up	33
5.7 I ² C Mode IO Structure (VDD or VDD2)	34
5.8 Matrix OE IO Structure (VDD or VDD2)	35
5.9 Register OE IO Structure (VDD or VDD2)	36
5.10 Register OE IO Structure (VDD or VDD2)	37
5.11 IO Typical Performance	38
6 Connection Matrix	40
6.1 Matrix Input Table	41
6.2 Matrix Output Table	42
6.3 Connection Matrix Virtual Inputs	45
6.4 Connection Matrix Virtual Outputs	46
7 Combination Function Macrocells	47
7.1 2-Bit LUT or D Flip-Flop Macrocells	47
7.2 2-bit LUT or Programmable Pattern Generator	50
7.3 3-Bit LUT or D Flip-Flop with Set/Reset Macrocells	52
7.4 3-Bit LUT or Pipe Delay/Ripple Counter Macrocell	59
8 Multi-Function Macrocells	64
8.1 3-Bit LUT or DFF/LATCH with 8-Bit Counter/Delay Macrocells	64
8.2 CNT/DLY/FSM Timing Diagrams	73
8.3 4-Bit LUT or DFF/LATCH with 16-Bit Counter/Delay Macrocell	82
8.4 Wake and Sleep Controller	85
9 Analog Comparators	89
9.1 ACMP0H Block Diagram	90
9.2 ACMP1H Block Diagram	91
9.3 ACMP2L Block Diagram	92
9.4 ACMP3L Block Diagram	93
9.5 ACMP Typical Performance	94
10 Programmable Delay/Edge Detector	98
10.1 Programmable Delay Timing Diagram - Edge Detector Output	98
11 Additional Logic Function. Deglitch Filter	99
12 Voltage Reference	100
12.1 Voltage Reference Overview	100
12.2 Vref Selection Table	100
12.3 Vref Block Diagram	101

SLG46827-A

Auto AEC-Q100 Qualified GreenPAK Programmable Mixed-Signal Matrix with In-System Debug

12.4 Vref Load Regulation	102
13 Clocking	104
13.1 Oscillator general description	104
13.2 Oscillator0 (2.048 kHz)	105
13.3 Oscillator1 (2.048 MHz)	106
13.4 Oscillator2 (25 MHz)	107
13.5 CNT/DLY Clock Scheme	108
13.6 External Clocking	108
13.7 Oscillators Power-On Delay	109
13.8 Oscillators Accuracy	111
14 Power-On Reset	114
14.1 General Operation	114
14.2 POR Sequence	115
14.3 Macrocells Output States During POR Sequence	115
15 I²C Serial Communications Macrocell	118
15.1 I ² C Serial Communications Macrocell Overview	118
15.2 I ² C Serial Communications Device Addressing	118
15.3 I ² C Serial General Timing	119
15.4 I ² C Serial Communications Commands	119
15.5 Chip Configuration Data Protection	122
15.6 I ² C Serial Command Register Map	123
15.7 I ² C Additional Options	124
16 Non-Volatile Memory	127
16.1 Serial NVM Write Operations	127
16.2 Serial NVM Read Operations	129
16.3 Serial NVM Erase Operations	129
17 Analog Temperature Sensor	130
18 Register Definitions	133
18.1 Register Map	133
19 Package Top Marking System Definition	172
19.1 TSSOP-20	172
20 Package Information	173
20.1 Package outlines for TSSOP 20L 173 MIL Green Package	173
20.2 TSSOP Handling	173
20.3 Soldering Information	174
21 Ordering Information	174
21.1 Tape and Reel Specifications	174
21.2 Carrier Tape Drawing and Dimensions	174
21.3 TSSOP-20L	174
22 Layout Guidelines	175
22.1 TSSOP-20	175
Glossary	176
Revision History	179

Figures

Figure 1: Block Diagram.....	7
Figure 2: Steps to Create a Custom GreenPAK Device.....	32
Figure 3: IO with I ² C Mode IO Structure Diagram.....	34
Figure 4: Matrix OE IO Structure Diagram.....	35
Figure 5: GPIO Register OE IO Structure Diagram.....	36
Figure 6: GPIO Register OE IO Structure Diagram.....	37
Figure 7: Typical High Level Output Current vs. High Level Output Voltage.....	38
Figure 8: Typical Low Level Output Current vs. Low Level Output Voltage (for 1x Drive).....	38
Figure 9: Typical Low Level Output Current vs. Low Level Output Voltage (for 2x Drive).....	39
Figure 10: Connection Matrix.....	40
Figure 11: Connection Matrix Example.....	40
Figure 12: 2-bit LUT0 or DFF0.....	47
Figure 13: 2-bit LUT1 or DFF1.....	48
Figure 14: 2-bit LUT2 or DFF2.....	48
Figure 15: DFF Polarity Operations.....	50
Figure 16: 2-bit LUT3 or PGen.....	51
Figure 17: PGen Timing Diagram.....	51
Figure 18: 3-bit LUT0 or DFF3.....	53
Figure 19: 3-bit LUT1 or DFF4.....	53
Figure 20: 3-bit LUT2 or DFF5.....	54
Figure 21: 3-bit LUT3 or DFF6.....	54
Figure 22: 3-bit LUT4 or DFF7.....	55
Figure 23: 3-bit LUT5 or DFF8.....	55
Figure 24: DFF Polarity Operations with nReset.....	58
Figure 25: DFF Polarity Operations with nSet.....	59
Figure 26: 3-bit LUT6/Pipe Delay/Ripple Counter.....	61
Figure 27: Example: Ripple Counter Functionality.....	62
Figure 28: Possible Connections Inside Multi-Function Macrocell.....	64
Figure 29: 8-bit Multi-Function Macrocells Block Diagram (3-bit LUT7/DFF10, CNT/DLY1).....	65
Figure 30: 8-bit Multi-Function Macrocells Block Diagram (3-bit LUT8/DFF11, CNT/DLY2).....	66
Figure 31: 8-bit Multi-Function Macrocells Block Diagram (3-bit LUT9/DFF12, CNT/DLY3).....	67
Figure 32: 8-bit Multi-Function Macrocells Block Diagram (3-bit LUT10/DFF13, CNT/DLY4).....	68
Figure 33: 8-bit Multi-Function Macrocells Block Diagram (3-bit LUT11/DFF14, CNT/DLY5).....	69
Figure 34: 8-bit Multi-Function Macrocells Block Diagram (3-bit LUT12/DFF15, CNT/DLY6).....	70
Figure 35: 8-bit Multi-Function Macrocells Block Diagram (3-bit LUT13/DFF16, CNT/DLY7).....	71
Figure 36: Delay Mode Timing Diagram, Edge Select: Both, Counter Data: 3.....	73
Figure 37: Delay Mode Timing Diagram for Different Edge Select Modes.....	74
Figure 38: Counter Mode Timing Diagram without Two DFFs Synced Up.....	74
Figure 39: Counter Mode Timing Diagram with Two DFFs Synced Up.....	75
Figure 40: One-Shot Function Timing Diagram.....	76
Figure 41: Frequency Detection Mode Timing Diagram.....	77
Figure 42: Edge Detection Mode Timing Diagram.....	78
Figure 43: Delayed Edge Detection Mode Timing Diagram.....	79
Figure 44: CNT/FSM Timing Diagram (Reset Rising Edge Mode, Oscillator is Forced On, UP = 0) for Counter Data = 3.....	80
Figure 45: CNT/FSM Timing Diagram (Set Rising Edge Mode, Oscillator is Forced On, UP = 0) for Counter Data = 3.....	80
Figure 46: CNT/FSM Timing Diagram (Reset Rising Edge Mode, Oscillator is Forced On, UP = 1) for Counter Data = 3.....	81
Figure 47: CNT/FSM Timing Diagram (Set Rising Edge Mode, Oscillator is Forced On, UP = 1) for Counter Data = 3.....	81
Figure 48: Counter Value, Counter Data = 3.....	82
Figure 49: 4-bit LUT0 or CNT/DLY0.....	83
Figure 50: Wake and Sleep Controller.....	85
Figure 51: Wake and Sleep Timing Diagram, Normal Wake Mode, Counter Reset is Used.....	86
Figure 52: Wake and Sleep Timing Diagram, Short Wake Mode, Counter Reset is Used.....	86
Figure 53: Wake and Sleep Timing Diagram, Normal Wake Mode, Counter Set is Used.....	87
Figure 54: Wake and Sleep Timing Diagram, Short Wake Mode, Counter Set is Used.....	87
Figure 55: ACMP0H Block Diagram.....	90
Figure 56: ACMP1H Block Diagram.....	91

**Auto AEC-Q100 Qualified GreenPAK
Programmable Mixed-Signal Matrix with In-System Debug**

Figure 57: ACMP2L Block Diagram	92
Figure 58: ACMP3L Block Diagram	93
Figure 59: Typical Propagation Delay vs. Vref for ACMPxH at T = 25 °C, Gain = 1, Buffer - Disabled, Hysteresis = 0	94
Figure 60: Typical Propagation Delay vs. Vref for ACMPxL at T = 25 °C, Gain = 1, Buffer - Disabled, Hysteresis = 0	94
Figure 61: ACMPxH Power-On Delay vs. V _{DD}	95
Figure 62: ACMPxL Power-On Delay vs. V _{DD}	95
Figure 63: ACMPxH Input Offset Voltage vs. Vref at T = -40 °C to 105 °C, Input Buffer Disabled	96
Figure 64: ACMPxH Input Offset Voltage vs. Vref at T = -40 °C to 105 °C, Input Buffer Enabled	96
Figure 65: ACMPxL Input Offset Voltage vs. Vref at T = -40 °C to 105 °C	97
Figure 66: ACMP Input Current Source vs. Input Voltage at T = -40 °C to 105 °C, V _{DD} = 3.3 V	97
Figure 67: Programmable Delay	98
Figure 68: Edge Detector Output	98
Figure 69: Deglitch Filter or Edge Detector	99
Figure 70: Voltage Reference Block Diagram	101
Figure 71: Typical Load Regulation, Vref = 320 mV, T = -40 °C to +105 °C, Buffer - Enable	102
Figure 72: Typical Load Regulation, Vref = 640 mV, T = -40 °C to +105 °C, Buffer - Enable	102
Figure 73: Typical Load Regulation, Vref = 1280 mV, T = -40 °C to +105 °C, Buffer - Enable	103
Figure 74: Typical Load Regulation, Vref = 2016 mV, T = -40 °C to +105 °C, Buffer - Enable	103
Figure 75: Oscillator0 Block Diagram	105
Figure 76: Oscillator1 Block Diagram	106
Figure 77: Oscillator2 Block Diagram	107
Figure 78: Clock Scheme	108
Figure 79: Oscillator Startup Diagram	109
Figure 80: Oscillator0 Maximum Power-On Delay vs. V _{DD} at T = 25 °C, OSC0 = 2.048 kHz	109
Figure 81: Oscillator1 Maximum Power-On Delay vs. V _{DD} at T = 25 °C, OSC1 = 2.048 MHz	110
Figure 82: Oscillator2 Maximum Power-On Delay vs. V _{DD} at T = 25 °C, OSC2 = 25 MHz	110
Figure 83: Oscillator0 Frequency vs. Temperature, OSC0 = 2.048 kHz	111
Figure 84: Oscillator1 Frequency vs. Temperature, OSC1 = 2.048 MHz	112
Figure 85: Oscillator2 Frequency vs. Temperature, OSC2 = 25 MHz	112
Figure 86: Oscillators Total Error vs. Temperature	113
Figure 87: POR Sequence	115
Figure 88: Internal Macrocell States during POR Sequence	116
Figure 89: Power-Down	117
Figure 90: Basic Command Structure	118
Figure 91: I ² C General Timing Characteristics	119
Figure 92: Byte Write Command, R/W = 0	119
Figure 93: Sequential Write Command	120
Figure 94: Current Address Read Command, R/W = 1	120
Figure 95: Random Read Command	121
Figure 96: Sequential Read Command	121
Figure 97: Reset Command Timing	122
Figure 98: Example of I ² C Byte Write Bit Masking	126
Figure 99: Page Write Command	127
Figure 100: I ² C Block Addressing	128
Figure 101: Analog Temperature Sensor Structure Diagram	131
Figure 102: Typical TS Output vs Temperature, V _{DD} = 2.3 V to 5.5 V	132

Tables

Table 1: Functional Pin Description.....	8
Table 2: Pin Type Definitions	11
Table 3: Absolute Maximum Ratings.....	12
Table 4: Electrostatic Discharge Ratings	12
Table 5: Recommended Operating Conditions	12
Table 6: EC at T = -40 °C to +105 °C, V _{DD} = 2.3 V to 5.5 V Unless Otherwise Noted	13
Table 7: Input Leakage Current at T = -40 °C to +105 °C.....	17
Table 8: EC of the SDA and SCL IO Stages at T = -40 °C to +105 °C, V _{DD} = 2.3 V to 5.5 V Unless Otherwise Noted	18
Table 9: I ² C Bus Timing Characteristics at T = -40 °C to +105 °C, V _{DD} = 2.3 V to 5.5 V Unless Otherwise Noted	19
Table 10: Typical Current Consumption Estimated for Each Macrocell at T = -40 °C to +105 °C	19
Table 11: Typical Delay Estimated for Each Macrocell at T = 25 °C.....	21
Table 12: Programmable Delay Expected Delays and Widths (Typical) at T = 25 °C	24
Table 13: Typical Filter Rejection Pulse Width at T = 25 °C	24
Table 14: Typical Counter/Delay Offset Measurements at T = 25 °C	24
Table 15: Oscillators Frequency Limits, V _{DD} = 2.3 V to 5.5 V.....	26
Table 16: Oscillators Power-On Delay at T = 25 °C, OSC Power Mode: "Auto Power-On".....	26
Table 17: ACMP Specifications at T = -40 °C to +105 °C, V _{DD} = 2.3 V to 5.5 V Unless Otherwise Noted.....	26
Table 18: TS Output vs Temperature (Output Range 1)	30
Table 19: TS Output vs Temperature (Output Range 2)	31
Table 20: TS Output Error (Output Range 1)	31
Table 21: TS Output Error (Output Range 2).....	31
Table 22: Matrix Input Table.....	41
Table 23: Matrix Output Table.....	42
Table 24: Connection Matrix Virtual Inputs	46
Table 25: 2-bit LUT0 Truth Table	49
Table 26: 2-bit LUT1 Truth Table	49
Table 27: 2-bit LUT2 Truth Table	49
Table 28: 2-bit LUT Standard Digital Functions	49
Table 29: 2-bit LUT1 Truth Table	52
Table 30: 2-bit LUT Standard Digital Functions	52
Table 31: 3-bit LUT0 Truth Table	56
Table 32: 3-bit LUT1 Truth Table	56
Table 33: 3-bit LUT2 Truth Table	56
Table 34: 3-bit LUT3 Truth Table	56
Table 35: 3-bit LUT4 Truth Table	56
Table 36: 3-bit LUT5 Truth Table	56
Table 37: 3-bit LUT Standard Digital Functions	57
Table 38: 3-bit LUT6 Truth Table	62
Table 39: 3-bit LUT7 Truth Table	72
Table 40: 3-bit LUT8 Truth Table	72
Table 41: 3-bit LUT9 Truth Table	72
Table 42: 3-bit LUT10 Truth Table	72
Table 43: 3-bit LUT11 Truth Table	72
Table 44: 3-bit LUT12 Truth Table	72
Table 45: 3-bit LUT13 Truth Table	72
Table 46: 4-bit LUT0 Truth Table	84
Table 47: 4-bit LUT Standard Digital Functions	84
Table 48: Vref Selection Table	100
Table 49: Oscillator Operation Mode Configuration Settings	104
Table 50: Oscillator Output Duty Cycle	113
Table 51: RPR Format	122
Table 52: RPR Bit Function Description.....	122
Table 53: NPR Format	123
Table 54: NPR Bit Function Description.....	123
Table 55: Read/Write Register Protection Options	123
Table 56: Erase Register Bit format	129
Table 57: Erase Register Bit Function Description.....	129
Table 58: Register Map.....	133

SLG46827-A

Auto AEC-Q100 Qualified GreenPAK
Programmable Mixed-Signal Matrix with In-System Debug

1 Block Diagram

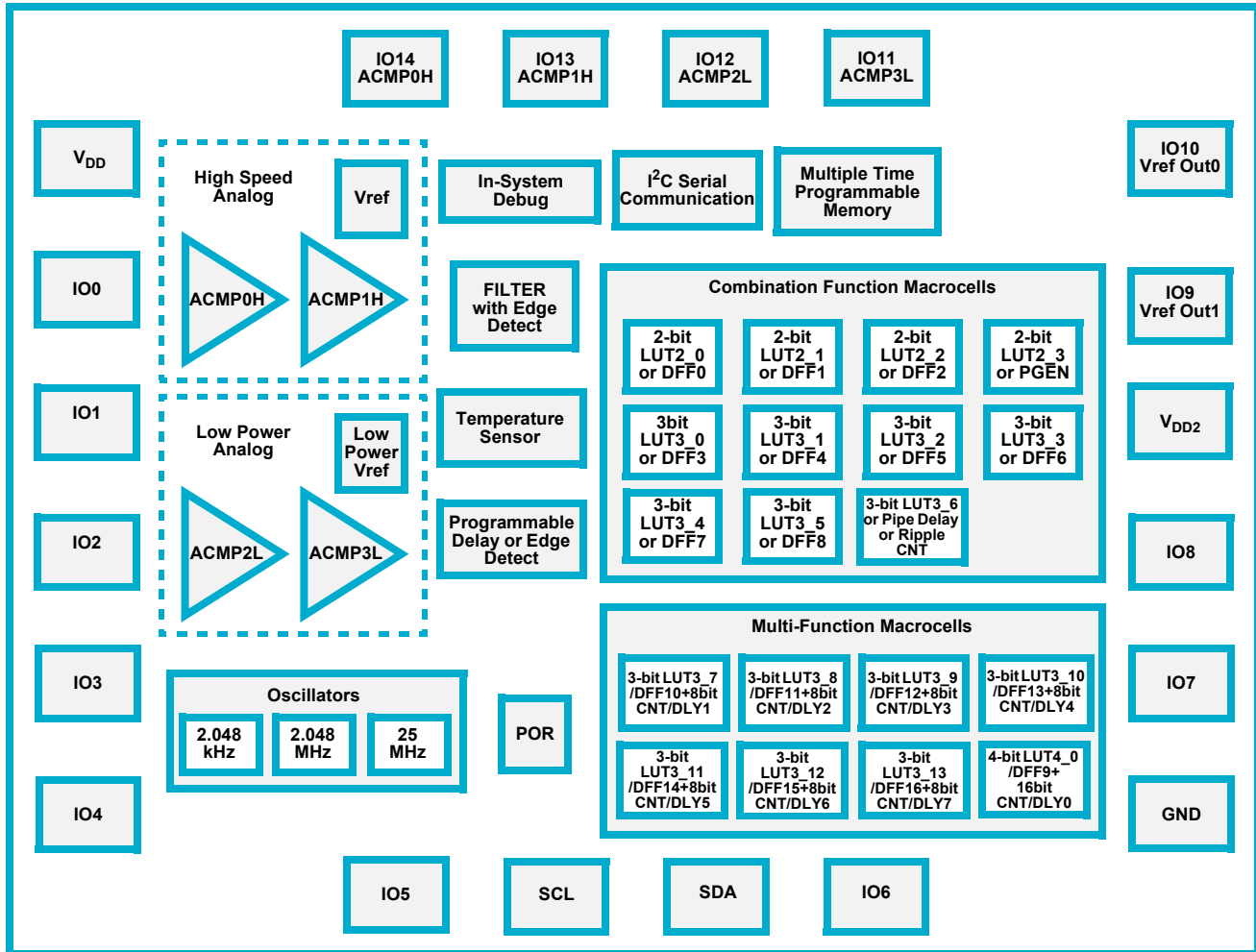

Figure 1: Block Diagram

SLG46827-A

Auto AEC-Q100 Qualified GreenPAK Programmable Mixed-Signal Matrix with In-System Debug

2 Pinout

2.1 PIN CONFIGURATION - TSSOP-20L

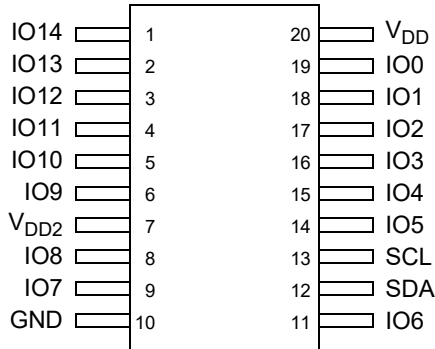

**TSSOP-20
(Top View)**

Pin #	Pin Name	Pin Functions
1	IO14	GPIO or ACMP0H_IN
2	IO13	GPIO or ACMP1H_IN
3	IO12	GPIO or ACMP2L_IN
4	IO11	GPIO or ACMP3L_IN
5	IO10	GPIO or Vref_OUT0
6	IO9	GPIO or Vref_OUT1
7	V _{DD2}	Power Supply
8	IO8	GPIO
9	IO7	GPO
10	GND	Ground
11	IO6	GPO
12	SDA	I ² C_SDA
13	SCL	I ² C_SCL
14	IO5	GPIO, SLA_3
15	IO4	GPIO, SLA_2
16	IO3	GPIO, SLA_1
17	IO2	GPIO, SLA_0
18	IO1	GPIO or Vref IN
19	IO0	GPIO
20	V _{DD}	Power Supply

Legend:

- ACMPx+:** ACMPx Positive Input
- ACMPx-:** ACMPx Negative Input
- SCL:** I²C Clock Input
- SDA:** I²C Data Input/Output
- Vrefx:** Voltage Reference Output
- SLA:** Slave Address

Table 1: Functional Pin Description

Pin #	Pin Name	Signal Name	Function	Input Options	Output Options
1	IO14	IO14	General Purpose IO with OE (Note 1)	Digital Input without Schmitt Trigger	Push-Pull (1x) (2x)
				Digital Input with Schmitt Trigger	Open-Drain NMOS (1x) (2x)
				Low Voltage Digital Input	--
		ACMP0H+	Analog Comparator 0 Positive Input	Analog	--
		EXT_RESET	--	--	--

SLG46827-A

Auto AEC-Q100 Qualified GreenPAK Programmable Mixed-Signal Matrix with In-System Debug

Table 1: Functional Pin Description(Continued)

Pin #	Pin Name	Signal Name	Function	Input Options	Output Options
2	IO13	IO13	General Purpose IO with OE (Note 1)	Digital Input without Schmitt Trigger	Push-Pull (1x) (2x)
				Digital Input with Schmitt Trigger	Open-Drain NMOS (1x) (2x)
		Low Voltage Digital Input	--		
		ACMP1H+	Analog Comparator 1 Positive Input	Analog	--
3	IO12	IO12	General Purpose IO with OE (Note 1)	Digital Input without Schmitt Trigger	Push-Pull (1x) (2x)
				Digital Input with Schmitt Trigger	Open-Drain NMOS (1x) (2x)
		Low Voltage Digital Input	--		
		ACMP2L+	Analog Comparator 2 Positive Input	Analog	--
4	IO11	IO11	General Purpose IO with OE (Note 1)	Digital Input without Schmitt Trigger	Push-Pull (1x) (2x)
				Digital Input with Schmitt Trigger	Open-Drain NMOS (1x) (2x)
		Low Voltage Digital Input	--		
		ACMP3L+	Analog Comparator 3 Positive Input	Analog	--
5	IO10	IO10	General Purpose IO with OE (Note 1)	Digital Input without Schmitt Trigger	Push-Pull (1x) (2x)
				Digital Input with Schmitt Trigger	Open-Drain NMOS (1x) (2x)
				Low Voltage Digital Input	--
		Vref0_OUT	Voltage Reference 0 Output	--	Analog
		EXT_OSC1_IN	--	--	--
6	IO9	IO9	General Purpose IO with OE (Note 1)	Digital Input without Schmitt Trigger	Push-Pull (1x) (2x)
				Digital Input with Schmitt Trigger	Open-Drain NMOS (1x) (2x)
				Low Voltage Digital Input	--
		Vref1_OUT	Voltage Reference 1 Output	--	Analog
		I ² C_EXPAND_3	--	--	--
7	V _{DD2}	V _{DD2}	Power Supply	--	--
8	IO8	IO8	General Purpose IO with OE (Note 1)	Digital Input without Schmitt Trigger	Push-Pull (1x) (2x)
				Digital Input with Schmitt Trigger	Open-Drain NMOS (1x) (2x)
		Low Voltage Digital Input	--		
		EXT_OSC2_IN	--	--	--
9	IO7	IO7	General Purpose Output	--	Push-Pull (1x) (2x)
				--	Open-Drain NMOS (1x) (2x)
				--	--
10	GND	GND	Ground	--	--

SLG46827-A

Auto AEC-Q100 Qualified GreenPAK Programmable Mixed-Signal Matrix with In-System Debug

Table 1: Functional Pin Description(Continued)

Pin #	Pin Name	Signal Name	Function	Input Options	Output Options
11	IO6	IO6	General Purpose Output	--	Push-Pull (1x) (2x)
12	SDA	SDA	I ² C Serial Data	Digital Input without Schmitt Trigger	--
				Digital Input with Schmitt Trigger	--
				Low Voltage Digital Input	--
13	SCL	SCL	I ² C Serial Clock	Digital Input without Schmitt Trigger	--
				Digital Input with Schmitt Trigger	--
				Low Voltage Digital Input	--
14	IO5	IO5	General Purpose IO with OE (Note 1)	Digital Input without Schmitt Trigger	Push-Pull (1x) (2x)
		EXT_SLA_3		Digital Input with Schmitt Trigger	Open-Drain NMOS (1x) (2x)
		I ² C_EXPAND_1		--	--
15	IO4	IO4	General Purpose IO with OE (Note 1)	Digital Input without Schmitt Trigger	Push-Pull (1x) (2x)
		EXT_SLA_2		Digital Input with Schmitt Trigger	Open-Drain NMOS (1x) (2x)
				Low Voltage Digital Input	--
16	IO3	IO3	General Purpose IO	Digital Input without Schmitt Trigger	Push-Pull (1x) (2x)
		EXT_SLA_1		Digital Input with Schmitt Trigger	Open-Drain NMOS (1x) (2x)
				Low Voltage Digital Input	--
17	IO2	IO2	General Purpose IO	Digital Input without Schmitt Trigger	Push-Pull (1x) (2x)
		EXT_SLA_0		Digital Input with Schmitt Trigger	Open-Drain NMOS (1x) (2x)
				Low Voltage Digital Input	--
18	IO1	IO1	General Purpose IO with OE (Note 1)	Digital Input without Schmitt Trigger	Push-Pull (1x) (2x)
				Digital Input with Schmitt Trigger	Open-Drain NMOS (1x) (2x)
				Low Voltage Digital Input	--
		EXT_Vref	Analog Comparator Negative Input	Analog	--

SLG46827-A

Auto AEC-Q100 Qualified GreenPAK Programmable Mixed-Signal Matrix with In-System Debug

Table 1: Functional Pin Description(Continued)

Pin #	Pin Name	Signal Name	Function	Input Options	Output Options
19	IO0	IO0	General Purpose IO	Digital Input without Schmitt Trigger	Push-Pull (1x) (2x)
				Digital Input with Schmitt Trigger	Open-Drain NMOS (1x) (2x)
				Low Voltage Digital Input	--
		I ² C_EXPAND_0	--	--	
		EXT_OSC0_IN	External Clock Connection	--	--
20	V _{DD}	VDD	Power Supply	--	--
		ACMP0H+	Analog Comparator 0 Positive Input	Analog	--
		ACMP1H+	Analog Comparator 1 Positive Input	Analog	--
		ACMP2L+	Analog Comparator 2 Positive Input	Analog	--
		ACMP3L+	Analog Comparator 3 Positive Input	Analog	--

Note 1 General Purpose IO's with OE can be used to implement bidirectional signals under user control via Connection Matrix to OE signal in IO structure.

Table 2: Pin Type Definitions

Pin Type	Description
V _{DD}	Power Supply
IO	Input/Output
SCL	I ² C Serial Clock
SDA	I ² C Serial Data
GND	Ground
V _{DD2}	Power Supply 2

SLG46827-A

Auto AEC-Q100 Qualified GreenPAK Programmable Mixed-Signal Matrix with In-System Debug

3 Characteristics

3.1 ABSOLUTE MAXIMUM RATINGS

Stresses beyond those listed under Absolute Maximum Ratings may cause permanent damage to the device. These are stress ratings only, so functional operation of the device at these or any other conditions beyond those indicated in the operational sections of the specification are not implied. Exposure to Absolute Maximum Rating conditions for extended periods may affect device reliability.

Table 3: Absolute Maximum Ratings

Parameter	Min	Max	Unit
Supply Voltage on V_{DD} relative to GND	-0.3	7	V
DC Input Voltage	GND - 0.5 V	$V_{DD} + 0.5 V$	V
Maximum Average or DC Current Through V_{DD} Pin	--	90	mA
Maximum Average or DC Current Through V_{DD2} Pin	--	90	mA
Maximum Average or DC Current Through GND Pin (Per chip side, Note 1)	--	100	mA
Maximum Average or DC Current (Through pin)	Push-Pull 1x	15.3	mA
	Push-Pull 2x	22.1	
	OD 1x	15.5	
	OD 2x	23	
Current at Input Pin	-1.0	1.0	mA
Input leakage (Absolute Value)	--	1000	nA
Storage Temperature Range	-65	150	°C
Junction Temperature	--	150	°C
Moisture Sensitivity Level	1		

Note 1 The GreenPAK's GND rail is divided in two sides. IOs 0 to 6, SCL, SDA are connected to one side and IOs 7 to 14 are connected to another side.

3.2 ELECTROSTATIC DISCHARGE RATINGS

Table 4: Electrostatic Discharge Ratings

Parameter	Min	Max	Unit
ESD Protection (Human Body Model)	2000	--	V
ESD Protection (Charged Device Model)	1300	--	V

3.3 RECOMMENDED OPERATING CONDITIONS

Table 5: Recommended Operating Conditions

Parameter	Condition	Min	Max	Unit
Supply Voltage (V_{DD})		2.3	5.5	V
	During NVM Write and Erase commands	2.5	5.5	V
Supply Voltage 2 (V_{DD2})	$V_{DD2} \leq V_{DD}$	1.71	5.5	V
Operating Temperature		-40	105	°C
Maximal Voltage Applied to any PIN in High Impedance State		--	$V_{DD} + 0.3$ Note 1	V
Capacitor Value at V_{DD}		0.1	--	μF
Analog Input Common Mode Range	Allowable Input Voltage at Analog Pins	0	V_{DD} or V_{DD2} Note 2	V

Note 1 IOs 0 to 6, SCL, SDA are powered from V_{DD} and IOs 7 to 14 are powered from V_{DD2} .
Note 2 V_{DD} for IO1 and V_{DD2} for IO11 to IO14

SLG46827-A

Auto AEC-Q100 Qualified GreenPAK Programmable Mixed-Signal Matrix with In-System Debug

3.4 ELECTRICAL CHARACTERISTICS

Table 6: EC at T = -40 °C to +105 °C, V_{DD} = 2.3 V to 5.5 V Unless Otherwise Noted

Parameter	Description	Condition	Min	Typ	Max	Unit
V _{IH}	HIGH-Level Input Voltage	Logic Input (Note 1)	0.7x V _{DD} (Note 2)	--	V _{DD} + 0.3 (Note 2)	V
		Logic Input with Schmitt Trigger	0.8x V _{DD} (Note 2)	--	V _{DD} + 0.3 (Note 2)	V
		Low-Level Logic Input (Note 1)	1.25	--	V _{DD} + 0.3 (Note 2)	V
V _{IL}	LOW-Level Input Voltage	Logic Input (Note 1)	GND- 0.3	--	0.3x V _{DD} (Note 2)	V
		Logic Input with Schmitt Trigger	GND- 0.3	--	0.2x V _{DD} (Note 2)	V
		Low-Level Logic Input (Note 1)	GND- 0.3	--	0.5	V
V _{HYS}	Schmitt Trigger Hysteresis Voltage	V _{DD2} = 1.8 V ± 5 %	0.195	0.38	0.559	V
		V _{DD} = 2.3 V	0.199	0.391	0.634	V
		V _{DD} = 3.3 V	0.232	0.422	0.604	V
		V _{DD} = 4.0 V	0.283	0.440	0.641	V
		V _{DD} = 5.5 V	0.370	0.577	0.785	V
V _O	Maximal Voltage Applied to any PIN in High Impedance State		--	--	V _{DD} + 0.3 (Note 2)	V
V _{OH}	HIGH-Level Output Voltage (Note 2)	Push-Pull, 1x Drive, I _{OH} = 1 mA, V _{DD} = V _{DD2} = 2.3 V	2.167	2.207	--	V
		Push-Pull, 1x Drive, I _{OH} = 3 mA, V _{DD} = V _{DD2} = 3.3 V	3.022	3.100	--	V
		Push-Pull, 1x Drive, I _{OH} = 3 mA, V _{DD} = V _{DD2} = 4.0 V	3.769	3.831	--	V
		Push-Pull, 1x Drive, I _{OH} = 5 mA, V _{DD} = V _{DD2} = 4.0 V	3.600	3.709	--	V
		Push-Pull, 1x Drive, I _{OH} = 5 mA, V _{DD} = V _{DD2} = 5.5 V	5.192	5.268	--	V
		Push-Pull, 2x Drive, I _{OH} = 1 mA, V _{DD} = V _{DD2} = 2.3 V	2.234	2.254	--	V
		Push-Pull, 2x Drive, I _{OH} = 3 mA, V _{DD} = V _{DD2} = 3.3 V	3.161	3.200	--	V
		Push-Pull, 2x Drive, I _{OH} = 3 mA, V _{DD} = V _{DD2} = 4.0 V	3.883	3.915	--	V
		Push-Pull, 2x Drive, I _{OH} = 5 mA, V _{DD} = V _{DD2} = 4.0 V	3.800	3.854	--	V
		Push-Pull, 2x Drive, I _{OH} = 5 mA, V _{DD} = V _{DD2} = 5.5 V	5.340	5.382	--	V
V _{OL}	LOW-Level Output Voltage (Note 2)	Push-Pull, 1x Drive, I _{OL} = 1 mA, V _{DD} = V _{DD2} = 2.3 V	--	0.069	0.100	V
		Push-Pull, 1x Drive, I _{OL} = 3 mA, V _{DD} = V _{DD2} = 3.3 V	--	0.154	0.222	V

SLG46827-A

Auto AEC-Q100 Qualified GreenPAK Programmable Mixed-Signal Matrix with In-System Debug

Table 6: EC at T = -40 °C to +105 °C, V_{DD} = 2.3 V to 5.5 V Unless Otherwise Noted(Continued)

Parameter	Description	Condition	Min	Typ	Max	Unit
V _{OL}	LOW-Level Output Voltage (Note 2)	Push-Pull, 1x Drive, I _{OL} = 3mA, V _{DD} = V _{DD2} = 4.0 V	--	0.133	0.192	V
		Push-Pull, 1x Drive, I _{OL} = 5 mA, V _{DD} = V _{DD2} = 4.0 V	--	0.226	0.327	V
		Push-Pull, 1x Drive, I _{OL} = 5 mA, V _{DD} = V _{DD2} = 5.5 V	--	0.188	0.268	V
		Push-Pull, 2x Drive, I _{OL} = 1 mA, V _{DD} = V _{DD2} = 2.3 V	--	0.036	0.051	V
		Push-Pull, 2x Drive, I _{OL} = 3 mA, V _{DD} = V _{DD2} = 3.3 V	--	0.079	0.113	V
		Push-Pull, 2x Drive, I _{OL} = 3mA, V _{DD} = V _{DD2} = 4.0 V	--	0.069	0.099	V
		Push-Pull, 2x Drive, I _{OL} = 5 mA, V _{DD} = V _{DD2} = 4.0 V	--	0.116	0.167	V
		Push-Pull, 2x Drive, I _{OL} = 5 mA, V _{DD} = V _{DD2} = 5.5 V	--	0.099	0.140	V
		NMOS OD, 1x Drive, I _{OL} = 1 mA, V _{DD} = V _{DD2} = 2.3 V	--	0.029	0.041	V
		NMOS OD, 1x Drive, I _{OL} = 3 mA, V _{DD} = V _{DD2} = 3.3 V	--	0.064	0.091	V
		NMOS OD, 1x Drive, I _{OL} = 3 mA, V _{DD} = V _{DD2} = 4.0 V	--	0.056	0.080	V
		NMOS OD, 1x Drive, I _{OL} = 5 mA, V _{DD} = V _{DD2} = 4.0 V	--	0.094	0.135	V
		NMOS OD, 1x Drive, I _{OL} = 5 mA, V _{DD} = V _{DD2} = 5.5 V	--	0.080	0.113	V
		NMOS OD, 2x Drive, I _{OL} = 1 mA, V _{DD} = V _{DD2} = 2.3 V	--	0.015	0.021	V
		NMOS OD, 2x Drive, I _{OL} = 3 mA, V _{DD} = V _{DD2} = 3.3 V	--	0.035	0.050	V
		NMOS OD, 2x Drive, I _{OL} = 3 mA, V _{DD} = V _{DD2} = 4.0 V	--	0.031	0.044	V
		NMOS OD, 2x Drive, I _{OL} = 5 mA, V _{DD} = V _{DD2} = 4.0 V	--	0.052	0.074	V
		NMOS OD, 2x Drive, I _{OL} = 5 mA, V _{DD} = V _{DD2} = 5.5 V	--	0.045	0.064	V
I _{OH}	HIGH-Level Output Current (Note 2) (Note 4)	Push-Pull, 1x Drive, V _{OH} = V _{DD} - 0.2 = V _{DD2} - 0.2 V _{DD} = V _{DD2} = 2.3 V Over lifetime at 105 °C (Note 3)	1.461	2.040	--	mA
		Push-Pull, 1x Drive, V _{OH} = 2.4 V, V _{DD} = V _{DD2} = 3.3 V	7.920	10.682	--	mA
		Push-Pull, 1x Drive, V _{OH} = 2.4 V, V _{DD} = V _{DD2} = 4.0 V	14.321	18.775	--	mA
		Push-Pull, 1x Drive, V _{OH} = 2.4 V, V _{DD} = V _{DD2} = 5.5 V	27.466	34.554	--	mA
		Push-Pull, 2x Drive, V _{OH} = V _{DD} - 0.2 = V _{DD2} - 0.2 V _{DD} = V _{DD2} = 2.3 V Over lifetime at 105 °C (Note 3)	2.678	3.987	--	mA

SLG46827-A

Auto AEC-Q100 Qualified GreenPAK Programmable Mixed-Signal Matrix with In-System Debug

Table 6: EC at T = -40 °C to +105 °C, V_{DD} = 2.3 V to 5.5 V Unless Otherwise Noted(Continued)

Parameter	Description	Condition	Min	Typ	Max	Unit
I _{OH}	HIGH-Level Output Current (Note 2) (Note 4)	Push-Pull, 2x Drive, V _{OH} = 2.4 V, V _{DD} = V _{DD2} = 3.3 V	15.288	20.800	--	mA
		Push-Pull, 2x Drive, V _{OH} = 2.4 V, V _{DD} = V _{DD2} = 4.0 V	27.581	36.524	--	mA
		Push-Pull, 2x Drive, V _{OH} = 2.4 V, V _{DD} = V _{DD2} = 5.5 V	52.371	66.673	--	mA
I _{OL}	LOW-Level Output Current (Note 2) (Note 4)	Push-Pull, 1x Drive, V _{OL} = 0.15 V, V _{DD} = V _{DD2} = 2.3 V Over lifetime at 105 °C (Note 3)	1.413	2.099	--	mA
		Push-Pull, 1x Drive, V _{OL} = 0.4 V, V _{DD} = V _{DD2} = 3.3 V	5.159	7.301	--	mA
		Push-Pull, 1x Drive, V _{OL} = 0.4 V, V _{DD} = V _{DD2} = 4.0 V	5.989	8.514	--	mA
		Push-Pull, 1x Drive, V _{OL} = 0.4 V, V _{DD} = V _{DD2} = 5.5 V	7.287	10.289	--	mA
		Push-Pull, 2x Drive, V _{OL} = 0.15 V, V _{DD} = V _{DD2} = 2.3 V Over lifetime at 105 °C (Note 3)	2.713	4.065	--	mA
		Push-Pull, 2x Drive, V _{OL} = 0.4 V, V _{DD} = V _{DD2} = 3.3	9.964	14.054	--	mA
		Push-Pull, 2x Drive, V _{OL} = 0.4 V, V _{DD} = V _{DD2} = 4.0	11.488	16.293	--	mA
		Push-Pull, 2x Drive, V _{OL} = 0.4 V, V _{DD} = V _{DD2} = 5.5	13.871	19.524	--	mA
		NMOS OD, 1x Drive, V _{OL} = 0.15 V, V _{DD} = V _{DD2} = 2.3 V Over lifetime at 105 °C (Note 3)	3.329	16.164	--	mA
		NMOS OD, 1x Drive, V _{OL} = 0.4 V, V _{DD} = V _{DD2} = 3.3 V	12.336	17.366	--	mA
		NMOS OD, 1x Drive, V _{OL} = 0.4 V, V _{DD} = V _{DD2} = 4.0 V	14.199	20.093	--	mA
		NMOS OD, 1x Drive, V _{OL} = 0.4 V, V _{DD} = V _{DD2} = 5.5 V	17.070	23.978	--	mA
		NMOS OD, 2x Drive, V _{OL} = 0.15 V, V _{DD} = V _{DD2} = 2.3 V Over lifetime at 105 °C (Note 3)	6.483	9.464	--	mA
		NMOS OD, 2x Drive, V _{OL} = 0.4 V, V _{DD} = V _{DD2} = 3.3 V	22.766	32.108	--	mA
		NMOS OD, 2x Drive, V _{OL} = 0.4 V, V _{DD} = V _{DD2} = 4.0 V	25.870	36.604	--	mA
NMOS OD, 2x Drive, V _{OL} = 0.4 V, V _{DD} = V _{DD2} = 5.5 V	30.115	42.783	--	mA		
T _{SU}	Startup Time	From V _{DD} rising past PON _{THR} T _{ramp} = 10ms	--	2.082	2.745	ms
T _{WR}	NVM Page Write Time	V _{DD} = 2.5 V to 5.5 V	--	--	20	ms
T _{ER}	NVM Page Erase Time	V _{DD} = 2.5 V to 5.5 V	--	--	20	ms
PON _{THR}	Power-On Threshold	V _{DD} Level Required to Start Up the Chip	1.521	1.843	2.117	V
POFF _{THR}	Power-Off Threshold	V _{DD} Level Required to Switch Off the Chip	0.839	1.242	1.593	V

SLG46827-A

Auto AEC-Q100 Qualified GreenPAK Programmable Mixed-Signal Matrix with In-System Debug

Table 6: EC at T = -40 °C to +105 °C, V_{DD} = 2.3 V to 5.5 V Unless Otherwise Noted(Continued)

Parameter	Description	Condition	Min	Typ	Max	Unit
R _{PULL}	Pull-up or Pull-down Resistance	1 M for Pull-up: V _{IN} = GND; for Pull-down: V _{IN} = V _{DD} (Note 2)	--	1	--	MΩ
		100 k for Pull-up: V _{IN} = GND; for Pull-down: V _{IN} = V _{DD} (Note 2)	--	100	--	kΩ
		10 k For Pull-up: V _{IN} = GND; for Pull-down: V _{IN} = V _{DD} (Note 2)	--	10	--	kΩ
C _{IN}	Input Capacitance		1.986	2.330	2.620	pF

Note 1 No hysteresis.

Note 2 The GreenPAK's power rails are divided in two sides. IOs 0 to 6, SCL, SDA are powered from V_{DD} (one side) and IOs 7 to 14 are powered from V_{DD2} (another side).

Note 3 Calculations based on HTOL drift data obtained through AEC-Q100 stress tests.

Note 4 DC or average current through any pin should not exceed value given in Absolute Maximum Conditions.

SLG46827-A

Auto AEC-Q100 Qualified GreenPAK Programmable Mixed-Signal Matrix with In-System Debug

Table 7: Input Leakage Current at T = -40 °C to +105 °C

Parameter	Description	Condition	Min	Typ	Max	Unit
I_{LKG} (Absolute Value)	Logic Input without Schmitt Trigger (Floating) Leakage (IO0-IO2, IO5, IO8, IO9-IO14)	$V_{IN} = V_{DD}, V_{DD} = V_{DD2}, V_{DD} = 2.3 \text{ V to } 5.5 \text{ V}$	--	0.008	7.022	nA
		$V_{IN} = 0 \text{ V}, V_{DD} = V_{DD2}, V_{DD} = 2.3 \text{ V to } 5.5 \text{ V}$	--	0.112	2.452	nA
	Logic Input without Schmitt Trigger (Floating) Leakage (SDA ans SCL Pins)	$V_{IN} = V_{DD}, V_{DD} = V_{DD2}, V_{DD} = 2.3 \text{ V to } 5.5 \text{ V}$	--	0.009	9.577	nA
		$V_{IN} = 0 \text{ V}, V_{DD} = V_{DD2}, V_{DD} = 2.3 \text{ V to } 5.5 \text{ V}$	--	0.016	0.765	nA
	Logic Input without Schmitt Trigger (Floating) Leakage (IO3, IO4)	$V_{IN} = V_{DD}, V_{DD} = V_{DD2}, V_{DD} = 2.3 \text{ V to } 5.5 \text{ V}$	--	0.013	10.868	nA
		$V_{IN} = 0 \text{ V}, V_{DD} = V_{DD2}, V_{DD} = 2.3 \text{ V to } 5.5 \text{ V}$	--	0.099	2.117	nA
	Logic Input without Schmitt Trigger (Floating) Leakage (IO8, IO9-IO14)	$V_{IN} = V_{DD2}, V_{DD2} = 1.8 \pm 5\%, V_{DD} = 2.3 \text{ V to } 5.5 \text{ V}$	--	0.004	5.109	nA
		$V_{IN} = 0 \text{ V}, V_{DD2} = 1.8 \pm 5\%, V_{DD} = 2.3 \text{ V to } 5.5 \text{ V}$	--	0.039	0.918	nA
	Logic Input with Schmitt Trigger (Floating) Leakage (IO0-IO2, IO5, IO8, IO9-IO14)	$V_{IN} = V_{DD}, V_{DD} = V_{DD2}, V_{DD} = 2.3 \text{ V to } 5.5 \text{ V}$	--	0.008	6.867	nA
		$V_{IN} = 0 \text{ V}, V_{DD} = V_{DD2}, V_{DD} = 2.3 \text{ V to } 5.5 \text{ V}$	--	0.111	2.272	nA
	Logic Input with Schmitt Trigger (Floating) Leakage (IO3, IO4)	$V_{IN} = V_{DD}, V_{DD} = V_{DD2}, V_{DD} = 2.3 \text{ V to } 5.5 \text{ V}$	--	0.013	10.724	nA
		$V_{IN} = 0 \text{ V}, V_{DD} = V_{DD2}, V_{DD} = 2.3 \text{ V to } 5.5 \text{ V}$	--	0.099	2.063	nA
	Logic Input with Schmitt Trigger (Floating) Leakage (IO8, IO9-IO14)	$V_{IN} = V_{DD2}, V_{DD2} = 1.8 \pm 5\%, V_{DD} = 2.3 \text{ V to } 5.5 \text{ V}$	--	0.004	5.098	nA
		$V_{IN} = 0 \text{ V}, V_{DD2} = 1.8 \pm 5\%, V_{DD} = 2.3 \text{ V to } 5.5 \text{ V}$	--	0.039	0.917	nA
	Low-Level Logic Input (Floating) Leakage (IO0-IO2, IO5, IO8, IO9-IO14)	$V_{IN} = V_{DD}, V_{DD} = V_{DD2}, V_{DD} = 2.3 \text{ V to } 5.5 \text{ V}$	--	0.008	6.803	nA
		$V_{IN} = 0 \text{ V}, V_{DD} = V_{DD2}, V_{DD} = 2.3 \text{ V to } 5.5 \text{ V}$	--	0.111	2.185	nA
	Low-Level Logic Input Trigger (Floating) Leakage (SDA ans SCL Pins)	$V_{IN} = V_{DD}, V_{DD} = V_{DD2}, V_{DD} = 2.3 \text{ V to } 5.5 \text{ V}$	--	0.009	9.250	nA
		$V_{IN} = 0 \text{ V}, V_{DD} = V_{DD2}, V_{DD} = 2.3 \text{ V to } 5.5 \text{ V}$	--	0.016	0.619	nA
	Low-Level Logic Input Trigger (Floating) Leakage (IO3, IO4)	$V_{IN} = V_{DD}, V_{DD} = V_{DD2}, V_{DD} = 2.3 \text{ V to } 5.5 \text{ V}$	--	0.013	10.547	nA
		$V_{IN} = 0 \text{ V}, V_{DD} = V_{DD2}, V_{DD} = 2.3 \text{ V to } 5.5 \text{ V}$	--	0.098	1.953	nA
Low-Level Logic Input Trigger (Floating) Leakage (IO8, IO9-IO14)	$V_{IN} = V_{DD2}, V_{DD2} = 1.8 \pm 5\%, V_{DD} = 2.3 \text{ V to } 5.5 \text{ V}$	--	0.004	5.072	nA	
	$V_{IN} = 0 \text{ V}, V_{DD2} = 1.8 \pm 5\%, V_{DD} = 2.3 \text{ V to } 5.5 \text{ V}$	--	0.039	0.910	nA	
ACMP Input Leakage	$V_{IN-} = 0 \text{ V}, V_{DD} = 2.3 \text{ V to } 5.5 \text{ V}$ Ext. Vref, Gain = 1	--	0.105	2.243	nA	
	$V_{IN+} = 0 \text{ V}, V_{DD} = 2.3 \text{ V to } 5.5 \text{ V}$ Ext. Vref, Gain = 1	--	0.164	4.385	nA	

SLG46827-A

Auto AEC-Q100 Qualified GreenPAK Programmable Mixed-Signal Matrix with In-System Debug

Table 7: Input Leakage Current at T = -40 °C to +105 °C(Continued)

Parameter	Description	Condition	Min	Typ	Max	Unit
I_{LKG} (Absolute Value)	ACMP Input Leakage	$V_{IN-} = V_{DD}$, $V_{DD} = 2.3$ V Ext. Vref, Gain = 1	--	0.006	5.752	nA
		$V_{IN+} = V_{DD}$, $V_{DD} = 2.3$ V Ext. Vref, Gain = 1	--	0.007	7.724	nA
		$V_{IN-} = V_{DD}$, $V_{DD} = 3.3$ V Ext. Vref, Gain = 1	--	0.007	7.911	nA
		$V_{IN+} = V_{DD}$, $V_{DD} = 3.3$ V Ext. Vref, Gain = 1	--	0.009	8.392	nA
		$V_{IN-} = V_{DD}$, $V_{DD} = 4$ V Ext. Vref, Gain = 1	--	0.008	9.441	nA
		$V_{IN+} = V_{DD}$, $V_{DD} = 4$ V Ext. Vref, Gain = 1	--	0.010	8.875	nA
		$V_{IN-} = V_{DD}$, $V_{DD} = 5.5$ V Ext. Vref, Gain = 1	--	0.011	12.928	nA
		$V_{IN+} = V_{DD}$, $V_{DD} = 5.5$ V Ext. Vref, Gain = 1	--	0.014	10.705	nA

Table 8: EC of the SDA and SCL IO Stages at T = -40 °C to +105 °C, $V_{DD} = 2.3$ V to 5.5 V Unless Otherwise Noted

Parameter	Description	Condition	Fast-Mode		Fast-Mode Plus		Unit
			Min	Max	Min	Max	
V_{IL}	LOW-level Input Voltage		-0.5	$0.3 \times V_{DD}$	-0.5	$0.3 \times V_{DD}$	V
V_{IH}	HIGH-level Input Voltage		$0.7 \times V_{DD}$	5.5	$0.7 \times V_{DD}$	5.5	V
V_{HYS}	Hysteresis of Schmitt Trigger Inputs		$0.05 \times V_{DD}$	--	$0.05 \times V_{DD}$	--	V
V_{OL1}	LOW-Level Output Voltage 1	(Open-Drain) at 3mA sink current $V_{DD} > 2$ V	0	0.4	0	0.4	V
V_{OL2}	LOW-Level Output Voltage 2	(Open-Drain) at 2 mA sink current $V_{DD} \leq 2$ V	0	$0.2 \times V_{DD}$	0	$0.2 \times V_{DD}$	V
I_{OL}	LOW-Level Output Current (Note 2)	$V_{OL} = 0.4$ V	3	--	20	--	mA
		$V_{OL} = 0.6$ V	6	--	--	--	mA
t_{of}	Output Fall Time from V_{IHmin} to V_{ILmax} (Note 1)		$14 \times (V_{DD}/5.5$ V)	250	$10 \times (V_{DD}/5.5$ V)	120	ns
t_{SP}	Input Filter Spike Suppression (SCL, SDA)	PIN configured as Digital Input	0	50	0	50	ns
		PIN configured as Digital Input LOW Voltage (Note 1)	0	2.5	0	2.5	ns
I_i	Input Current each IO Pin	$0.1 \times V_{DD} < V_I < 0.9 \times V_{DDmax}$	-10	+10	-10	+10	μ A
C_i	Capacitance for each IO Pin		--	10	--	10	pF

Note 1 Does not meet standard I²C specifications: $t_{of(min)} = 20 \times (V_{DD}/5.5$ V); $t_{SP} = 50$ ns

Note 2 For Fast-mode Plus SDA pin must be configured as NMOS 2x Open-Drain, see register [769] in Section 18.

SLG46827-A

Auto AEC-Q100 Qualified GreenPAK Programmable Mixed-Signal Matrix with In-System Debug

Table 9: I²C Bus Timing Characteristics at T = -40 °C to +105 °C, V_{DD} = 2.3 V to 5.5 V Unless Otherwise Noted

Parameter	Description	Condition	Fast-Mode		Fast-Mode Plus		Unit
			Min	Max	Min	Max	
F _{SCL}	Clock Frequency, SCL		--	400	--	1000	kHz
t _{LOW}	Clock Pulse Width Low		1300	--	500	--	ns
t _{HIGH}	Clock Pulse Width High		600	--	260	--	ns
t _{BUF}	Bus Free Time between Stop and Start		1300	--	500	--	ns
t _{HD_STA}	Start Hold Time		600	--	260	--	ns
t _{SU_STA}	Start Set-up Time		600	--	260	--	ns
t _{HD_DAT}	Data Hold Time		0	--	0	--	ns
t _{SU_DAT}	Data Set-up Time		100	--	50	--	ns
t _R	Inputs Rise Time		--	300	--	120	ns
t _F	Inputs Fall Time		--	300	--	120	ns
t _{SU_STO}	Stop Set-up Time		600	--	260	--	ns
t _{VD_ACK}	Data valid acknowledge time		--	900	--	450	ns
t _{VD_DAT}	Data valid time		--	900	--	450	ns

Note 1 Timing diagram can be found in the [Figure 91](#)

Table 10: Typical Current Consumption Estimated for Each Macrocell at T = -40 °C to +105 °C

Parameter	Description	Note	V _{DD} = 2.3 V	V _{DD} = 3.3 V	V _{DD} = 5.0 V	Unit
I	Current	Chip Quiescent Current	0.33	0.39	0.48	μA
		OSC 2.048 kHz Force PWR On	0.24	0.25	0.28	μA
		OSC 2.048 MHz Force PWR On; Matrix PWR Down; Pre-Divider = 1; Second Divider = 1	22.16	25.29	31.10	μA
		OSC 2.048 MHz Force PWR On; Matrix PWR Down; Pre-Divider = 4; Second Divider = 1	18.37	19.51	21.57	μA
		OSC 2.048 MHz Force PWR On; Matrix PWR Down; Pre-Divider = 8; Second Divider = 1	17.72	18.52	19.93	μA
		OSC 25 MHz Force PWR On; Matrix PWR Down; Pre-Divider = 1; Second Divider = 1	44.88	59.09	85.34	μA

SLG46827-A

Auto AEC-Q100 Qualified GreenPAK Programmable Mixed-Signal Matrix with In-System Debug

Table 10: Typical Current Consumption Estimated for Each Macrocell at T = -40 °C to +105 °C (Continued)

Parameter	Description	Note	V _{DD} = 2.3 V	V _{DD} = 3.3 V	V _{DD} = 5.0 V	Unit
I	Current	OSC 25 MHz Force PWR On; Matrix PWR Down; Pre-Divider = 4; Second Divider = 1	30.68	38.36	53.25	μA
		OSC 25 MHz Force PWR On; Matrix PWR Down; Pre-Divider = 8; Second Divider = 1	28.06	34.54	47.32	μA
		Temp Sensor; Output Range 2; Source: Matrix	14.01	14.06	14.37	μA
		Temp Sensor; Output Range 1; Source: Matrix	14.14	14.19	14.50	μA
		Vref0	7.04	7.06	7.18	μA
		Vref1	0.99	0.99	0.99	μA
		Vref0; Source: ACMP0H; Vref = 32 mV; Buffer On	10.60	10.71	11.60	μA
		Vref0; Source: None; Buffer On	12.03	12.25	12.94	μA
		Vref1; Source: ACMP2L; Vref = 32 mV; Buffer On	6.35	6.42	6.76	μA
		Vref1; Source: None; Buffer On	5.97	6.03	6.36	μA
		ACMP0H; 100 uA Dis; Gain: Any; IN PIN1; Vref = 32mV	20.80	21.29	22.39	μA
		ACMP2L; Gain: Any; IN PIN3; Vref = 32 mV	1.23	1.23	1.25	μA
		ACMP0H,1H; 100 uA Dis; Hyst Dis; Gain x1; IN PIN1, 2; Vref = 32 mV	34.43	35.34	37.44	μA
		ACMP2L,3L; Hyst Dis; Gain x1; IN PIN3, 4; Vref = 32 mV	1.48	1.48	1.51	μA
		ACMP0H; 100 uA Dis; Hyst Dis; Gain x1; IN V _{DD} ; Vref = 32 mV	34.41	35.24	37.11	μA
		ACMP0H; 100 uA Dis; Hyst Dis; Gain x1; IN BUFF PIN1; Vref = 32 mV	24.23	24.72	25.97	μA
		ACMP0H; 100 uA EN; Hyst Dis; Gain x1; IN PIN1; Vref = 32 mV	46.87	48.39	51.82	μA
		ACMP0H,1H,2L,3L; Hyst Dis; Gain x1; IN PIN1, 2, 3, 4; Vref = 32 mV	35.75	36.67	38.83	μA
		ACMP0H; WS En; Force Sleep Low; WT Short; CNT Data = 1	1.03	1.10	1.91	μA
		ACMP0H; WS En; Force Sleep Low; WT Short; CNT Data = 10	0.39	0.42	0.59	μA
		ACMP0H; WS En; Force Sleep Low; WT Short; CNT Data = 100	0.27	0.28	0.33	μA
		ACMP0H,1H; WS En; Force Sleep Low; WT Short; CNT Data = 1	1.58	1.68	2.85	μA
		ACMP0H,1H; WS En; Force Sleep Low; WT Short; CNT Data = 10	0.49	0.52	0.76	μA

SLG46827-A

Auto AEC-Q100 Qualified GreenPAK Programmable Mixed-Signal Matrix with In-System Debug

Table 10: Typical Current Consumption Estimated for Each Macrocell at T = -40 °C to +105 °C (Continued)

Parameter	Description	Note	V _{DD} = 2.3 V	V _{DD} = 3.3 V	V _{DD} = 5.0 V	Unit
I	Current	ACMP0H,1H; WS En; Force Sleep Low; WT Short; CNT Data = 100	0.28	0.29	0.35	μA
		ACMP0H,1H; IN BUF PIN1,2; WS En; Force Sleep Low; WT Short; CNT Data = 1	1.83	1.97	3.42	μA
		ACMP0H,1H; IN BUF PIN1,2; WS En; Force Sleep Low; WT Short; CNT Data = 10	0.54	0.57	0.87	μA
		ACMP0H,1H; IN BUF PIN1,2; WS En; Force Sleep Low; WT Short; CNT Data = 100	0.28	0.3	0.36	μA
		ACMP0H; WS En; Force Sleep Low; WT Normal; CNT Data = 1	10.76	11.23	12.58	μA
		ACMP0H; WS En; Force Sleep Low; WT Normal; CNT Data = 10	2.17	2.27	2.53	μA
		ACMP0H; WS En; Force Sleep Low; WT Normal; CNT Data = 100	0.46	0.49	0.54	μA
		ACMP0H,1H; WS En; Force Sleep Low; WT Normal; CNT Data = 1	17.66	18.50	20.63	μA
		ACMP0H,1H; WS En; Force Sleep Low; WT Normal; CNT Data = 10	3.43	3.59	4	μA
		ACMP0H,1H; WS En; Force Sleep Low; WT Normal; CNT Data = 100	0.60	0.63	0.70	μA
		ACMP0H,1H; IN BUF PIN1,2; WS En; Force Sleep Low; WT Normal; CNT Data = 1	21.13	22.07	24.58	μA
		ACMP0H,1H; IN BUF PIN1,2; WS En; Force Sleep Low; WT Normal; CNT Data = 10	4.06	4.24	4.72	μA
		ACMP0H,1H; IN BUF PIN1,2; WS En; Force Sleep Low; WT Normal; CNT Data = 100	0.67	0.70	0.78	μA

3.5 TIMING CHARACTERISTICS

Table 11: Typical Delay Estimated for Each Macrocell at T = 25 °C

Parameter	Description	Note	V _{DD} = 2.5 V		V _{DD} = 3.3 V		V _{DD} = 5 V		Unit
			Rising	Falling	Rising	Falling	Rising	Falling	
tpd	Delay	Multi-Function DFF Q	23	26	16	19	11	14	ns
tpd	Delay	Multi-Function DFF nQ	24	26	17	19	12	14	ns
tpd	Delay	Multi-Function DFF nRESET Q	--	30	--	21	--	15	ns
tpd	Delay	Multi-Function DFF nRESET nQ	27	--	18	--	13	--	ns
tpd	Delay	Multi-Function DFF nSET Q	27	--	19	--	13	--	ns
tpd	Delay	Multi-Function DFF nSET nQ	--	30	--	22	--	15	ns
tpd	Delay	DFF Q	18	22	13	16	9	11	ns

SLG46827-A

Auto AEC-Q100 Qualified GreenPAK Programmable Mixed-Signal Matrix with In-System Debug

Table 11: Typical Delay Estimated for Each Macrocell at T = 25 °C(Continued)

Parameter	Description	Note	V _{DD} = 2.5 V		V _{DD} = 3.3 V		V _{DD} = 5 V		Unit
			Rising	Falling	Rising	Falling	Rising	Falling	
tpd	Delay	DFF nQ	19	22	13	16	9	11	ns
tpd	Delay	DFF nRESET Q	--	23	--	16	--	11	ns
tpd	Delay	DFF nRESET nQ	19	--	13	--	9	--	ns
tpd	Delay	DFF nSET Q	19	--	13	--	9	--	ns
tpd	Delay	DFF nSET nQ	--	23	--	16	--	11	ns
tpd	Delay	DFF3 First Q	19	23	13	17	9	12	ns
tpd	Delay	DFF3 First nQ	20	23	14	17	10	12	ns
tpd	Delay	DFF3 First nRESET Q	--	24	--	17	--	12	ns
tpd	Delay	DFF3 First nRESET nQ	21	--	14	--	9	--	ns
tpd	Delay	DFF3 First nSET Q	20	--	14	--	9	--	ns
tpd	Delay	DFF3 First nSET nQ	--	24	--	17	--	12	ns
tpd	Delay	DFF3 Second Q	18	22	12	16	8	11	ns
tpd	Delay	DFF3 Second nQ	19	21	13	15	8	11	ns
tpd	Delay	DFF3 Second nRESET Q	--	24	--	17	--	12	ns
tpd	Delay	DFF3 Second nRESET nQ	20	--	14	--	9	--	ns
tpd	Delay	DFF3 Second nSET Q	20	--	13	--	9	--	ns
tpd	Delay	DFF3 Second nSET nQ	--	24	--	17	--	12	ns
tpd	Delay	Multi-Function LATCH Q	22	25	15	18	11	13	ns
tpd	Delay	Multi-Function LATCH nQ	23	25	15	19	11	13	ns
tpd	Delay	Multi-Function LATCH nRESET Q	--	31	--	22	--	16	ns
tpd	Delay	Multi-Function LATCH nRESET nQ	28	--	19	--	13	--	ns
tpd	Delay	Multi-Function LATCH nSET Q	26	--	17	--	12	--	ns
tpd	Delay	Multi-Function LATCH nSET nQ	--	29	--	21	--	15	ns
tpd	Delay	LATCH Q	17	20	12	14	8	10	ns
tpd	Delay	LATCH nQ	17	21	11	15	7	11	ns
tpd	Delay	LATCH nRESET Q	--	24	--	17	--	12	ns
tpd	Delay	LATCH nRESET nQ	21	--	14	--	10	--	ns
tpd	Delay	LATCH nSET Q	18	--	12	--	8	--	ns
tpd	Delay	LATCH nSET nQ	--	22	--	15	--	11	ns
tpd	Delay	LATCH3 First Q	18	21	13	15	9	10	ns
tpd	Delay	LATCH3 First nQ	18	22	12	16	8	11	ns
tpd	Delay	LATCH3 First nRESET Q	--	25	--	18	--	12	ns
tpd	Delay	LATCH3 First nRESET nQ	22	--	15	--	10	--	ns
tpd	Delay	LATCH3 First nSET Q	19	--	13	--	9	--	ns
tpd	Delay	LATCH3 First nSET nQ	--	23	--	16	--	11	ns
tpd	Delay	LATCH3 Second Q	20	24	14	18	10	12	ns
tpd	Delay	LATCH3 Second nQ	21	23	15	17	10	12	ns
tpd	Delay	LATCH3 Second nRESET Q	--	25	--	18	--	12	ns

SLG46827-A

Auto AEC-Q100 Qualified GreenPAK Programmable Mixed-Signal Matrix with In-System Debug

Table 11: Typical Delay Estimated for Each Macrocell at T = 25 °C(Continued)

Parameter	Description	Note	V _{DD} = 2.5 V		V _{DD} = 3.3 V		V _{DD} = 5 V		Unit
			Rising	Falling	Rising	Falling	Rising	Falling	
tpd	Delay	LATCH3 Second nRESET nQ	22	--	15	--	10	--	ns
tpd	Delay	LATCH3 Second nSET Q	19	--	13	--	9	--	ns
tpd	Delay	LATCH3 Second nSET nQ	--	22	--	16	--	11	ns
tpd	Delay	Multi-Function 3-bit LUT	22	24	15	17	11	12	ns
tpd	Delay	Multi-Function 3-bit LUT, CNT Delay	52	54	37	39	25	27	ns
tpd	Delay	Multi-Function 4-bit LUT	22	25	15	18	11	13	ns
tpd	Delay	Multi-Function 4-bit LUT, CNT Delay	54	53	38	38	26	27	ns
tpd	Delay	2-bit LUT	17	17	11	12	8	8	ns
tpd	Delay	3-bit LUT	16	17	11	12	8	9	ns
tpd	Delay	Digital input to Low Voltage to PP 1x	32	226	23	153	18	90	ns
tpd	Delay	Digital input to with Schmitt Trigger to PP 1x	30	35	22	26	17	19	ns
tpd	Delay	Digital input to 1xPP	29	34	21	25	15	19	ns
tpd	Delay	Digital input to 2xPP	28	33	20	24	15	18	ns
tpd	Delay	Digital input to 1xNMOS	--	31	--	23	--	17	ns
tpd	Delay	Digital input to 2xNMOS	--	30	--	22	--	17	ns
tpd	Delay	Digital input to 1x3-State (Z to 0)	--	28	--	20	--	15	ns
tpd	Delay	Digital input to 2x3-State (Z to 0)	--	27	--	20	--	14	ns
tpd	Delay	Digital input to 1x3-State (Z to 1)	30	--	22	--	16	--	ns
tpd	Delay	Digital input to 2x3-State (Z to 1)	29	--	21	--	16	--	ns
tpd	Delay	Digital input to 1xOE (Z to 0)	--	28	--	20	--	15	ns
tpd	Delay	Digital input to 1xOE (Z to 1)	30	--	22	--	16	--	ns
tpd	Delay	Ripple CNT CLK UP Q0	27	17	19	20	13	14	ns
tpd	Delay	Ripple CNT CLK UP Q1	32	16	23	20	16	15	ns
tpd	Delay	Ripple CNT CLK UP Q2	38	15	27	19	19	15	ns
tpd	Delay	Ripple CNT CLK DOWN Q0	26	28	19	21	13	15	ns
tpd	Delay	Ripple CNT CLK DOWN Q1	27	34	19	25	13	18	ns
tpd	Delay	Ripple CNT CLK DOWN Q2	26	42	19	30	13	22	ns
tpd	Delay	Ripple CNT nSET UP Q0	24	49	16	36	11	25	ns
tpd	Delay	Ripple CNT nSET UP Q1	23	54	16	39	11	28	ns
tpd	Delay	Ripple CNT nSET UP Q2	21	60	15	44	10	31	ns
tpd	Delay	Ripple CNT nSET DOWN Q0	24	47	16	35	11	25	ns
tpd	Delay	Ripple CNT nSET DOWN Q1	23	46	16	33	11	24	ns
tpd	Delay	Ripple CNT nSET DOWN Q2	21	45	14	33	10	23	ns
tpd	Delay	Edge detect	23	22	16	15	11	10	ns
tw	Width	Edge detect	214	215	158	159	116	116	ns
tpd	Delay	Edge detect Delayed	237	238	174	175	126	127	ns

SLG46827-A

Auto AEC-Q100 Qualified GreenPAK Programmable Mixed-Signal Matrix with In-System Debug

Table 11: Typical Delay Estimated for Each Macrocell at T = 25 °C(Continued)

Parameter	Description	Note	V _{DD} = 2.5 V		V _{DD} = 3.3 V		V _{DD} = 5 V		Unit
			Rising	Falling	Rising	Falling	Rising	Falling	
tpd	Delay	Filter Q	167	147	114	103	71	68	ns
tpd	Delay	Filter nQ	147	168	102	115	67	72	ns
tpd	Delay	PGen CLK	17	21	12	16	8	11	ns
tpd	Delay	PGen nRESET (Z to 0)	--	21	--	15	--	11	ns
tpd	Delay	PGen nRESET (Z to 1)	19	--	13	--	9	--	ns
tpd	Delay	Pipe Delay OUT0 Q PD number = 1	30	32	21	23	15	17	ns
tpd	Delay	Pipe Delay OUT1 Q PD number = 1	30	32	21	24	15	17	ns
tpd	Delay	Pipe Delay OUT1 nQ PD number = 1	31	35	22	26	15	18	ns
tpd	Delay	Pipe Delay OUT0 nRESET Q PD number = 1	--	28	--	21	--	15	ns
tpd	Delay	Pipe Delay OUT1 nRESET Q PD number = 1	--	29	--	21	--	15	ns
tpd	Delay	Pipe Delay OUT1 nRESET nQ PD number = 1	27	--	19	--	14	--	ns

Table 12: Programmable Delay Expected Delays and Widths (Typical) at T = 25 °C

Parameter	Description	Note	V _{DD} = 2.5 V	V _{DD} = 3.3V	V _{DD} = 5.0V	Unit
tw	Pulse Width, 1 cell	mode: (any) edge detect, edge detect output	214	158	116	ns
tw	Pulse Width, 2 cell	mode: (any) edge detect, edge detect output	424	313	229	ns
tw	Pulse Width, 3 cell	mode: (any) edge detect, edge detect output	634	467	342	ns
tw	Pulse Width, 4 cell	mode: (any) edge detect, edge detect output	844	622	455	ns
time1	Delay, 1 cell	mode: (any) edge detect, edge detect output	21	14	10	ns
time1	Delay, 2 cell	mode: (any) edge detect, edge detect output	21	14	10	ns
time1	Delay, 3 cell	mode: (any) edge detect, edge detect output	21	14	10	ns
time1	Delay, 4 cell	mode: (any) edge detect, edge detect output	21	15	10	ns
time2	Delay, 1 cell	mode: both edge delay, edge detect output	236	173	126	ns
time2	Delay, 2 cell	mode: both edge delay, edge detect output	446	327	239	ns
time2	Delay, 3 cell	mode: both edge delay, edge detect output	656	482	351	ns
time2	Delay, 4 cell	mode: both edge delay, edge detect output	866	637	464	ns

Table 13: Typical Filter Rejection Pulse Width at T = 25 °C

Parameter	V _{DD} = 2.5 V	V _{DD} = 3.3V	V _{DD} = 5.0V	Unit
Filtered Pulse Width	< 123	< 84	< 52	ns

Table 14: Typical Counter/Delay Offset Measurements at T = 25 °C

Parameter	OSC Freq	OSC Power	V _{DD} = 2.5 V	V _{DD} = 3.3V	V _{DD} = 5.0V	Unit
Power-ON time	25 MHz	auto	0.14	0.14	0.14	μs
Power-ON time	2.048 MHz	auto	0.51	0.46	0.41	μs

SLG46827-A

Auto AEC-Q100 Qualified GreenPAK Programmable Mixed-Signal Matrix with In-System Debug

Table 14: Typical Counter/Delay Offset Measurements at T = 25 °C(Continued)

Parameter	OSC Freq	OSC Power	V _{DD} = 2.5 V	V _{DD} = 3.3V	V _{DD} = 5.0V	Unit
Power-ON time	2.048 kHz	auto	705	604	486	μs
frequency settling time	25 MHz	auto	4	4	8	μs
frequency settling time	2.048 MHz	auto	0.3	0.4	0.4	μs
frequency settling time	2.048 kHz	auto	660	570	480	μs
variable (CLK period)	25 MHz	forced	0-40	0-40	0-40	ns
variable (CLK period)	2.048 MHz	forced	0-0.5	0-0.5	0-0.5	μs
variable (CLK period)	2.048 kHz	forced	0-488	0-488	0-488	μs
tpd (non-delayed edge)	25 MHz/ 2.048 kHz	either	35	14	10	ns

SLG46827-A

Auto AEC-Q100 Qualified GreenPAK Programmable Mixed-Signal Matrix with In-System Debug

3.6 OSC CHARACTERISTICS

3.6.1 OSC Specifications

Table 15: Oscillators Frequency Limits, $V_{DD} = 2.3\text{ V to }5.5\text{ V}$

OSC	Temperature Range					
	+25 °C			-40 °C to +105 °C		
	Minimum Value, kHz	Maximum Value, kHz	Error, %	Minimum Value, kHz	Maximum Value, kHz	Error, %
2.048 kHz OSC0	2.017	2.088	-1.51	1.830	2.097	-10.64
			+1.95			2.39
2.048 MHz OSC1	2012.696	2084.811	-1.72	1949.486	2089.938	-4.81
			+1.80			+2.05
25 MHz OSC2	24542.143	25541.706	-1.83	23680.428	25573.976	-5.28
			2.17			+2.30

3.6.2 OSC Power-On Delay

Table 16: Oscillators Power-On Delay at $T = 25\text{ °C}$, OSC Power Mode: "Auto Power-On"

Power Supply Range (V_{DD}), V	Oscillator2 25 MHz		Oscillator2 25 MHz Start with delay		Oscillator1 2.048 MHz		Oscillator0 2.048 kHz	
	Typical Value, ns	Maximum Value, ns	Typical Value, ns	Maximum Value, ns	Typical Value, ns	Maximum Value, ns	Typical Value, μs	Maximum Value, μs
2.3	43.844	59.862	145.991	163.927	527.828	558.805	755.871	1141.833
2.5	38.807	51.244	144.046	162.859	505.070	541.510	712.941	1066.115
3.0	30.497	40.400	141.900	163.675	469.337	511.057	639.114	930.827
3.3	27.357	36.686	141.517	164.780	455.916	497.886	608.531	873.573
3.6	24.944	33.393	141.397	165.476	445.562	487.231	584.415	827.475
4.0	22.527	30.599	141.366	166.690	434.368	475.042	558.844	777.883
5.0	18.789	25.868	141.627	168.998	411.165	453.440	511.201	686.248
5.5	17.591	24.709	141.713	169.854	406.866	445.683	485.845	642.574

3.7 ACMP SPECIFICATIONS

Table 17: ACMP Specifications at $T = -40\text{ °C to }+105\text{ °C}$, $V_{DD} = 2.3\text{ V to }5.5\text{ V}$ Unless Otherwise Noted

Parameter	Description	Note	Condition	Min	Typ	Max	Unit
V_{ACMP}	ACMP0H, ACMP1H, ACMP2L, ACMP3L Input Voltage Range	Positive Input		0	--	V_{DD}	V
		Negative Input		0	--	V_{DD}	V

SLG46827-A

Auto AEC-Q100 Qualified GreenPAK Programmable Mixed-Signal Matrix with In-System Debug

Table 17: ACMP Specifications at T = -40 °C to +105 °C, V_{DD} = 2.3 V to 5.5 V Unless Otherwise Noted(Continued)

Parameter	Description	Note	Condition	Min	Typ	Max	Unit	
V _{offset}	ACMP0H, ACMP1H Input Offset Voltage	V _{hys} = 0 mV, Gain = 1, V _{ref} = 32 mV	T = 25 °C	-8.765	--	5.135	mV	
				-8.765	--	5.212	mV	
	ACMP2L, ACMP3L Input Offset Voltage		T = 25 °C	-7.511	--	4.086	mV	
				-7.937	--	4.143	mV	
	ACMP0H, ACMP1H Input Offset Voltage		V _{hys} = 0 mV, Gain = 1, V _{ref} = 1024 mV	T = 25 °C	-5.656	--	6.200	mV
					-5.942	--	6.400	mV
	ACMP2L, ACMP3L Input Offset Voltage			T = 25 °C	-4.968	--	6.220	mV
					-5.387	--	6.295	mV
ACMP0H, ACMP1H Input Offset Voltage	V _{hys} = 0 mV, Gain = 1, V _{ref} = 2016 mV	T = 25 °C		-3.610	--	9.525	mV	
				-4.741	--	9.964	mV	
ACMP2L, ACMP3L Input Offset Voltage		T = 25 °C		-4.174	--	8.894	mV	
				-4.436	--	9.266	mV	
t _{start}		ACMP0H, ACMP1H Start Time	ACMP Power-On delay, Minimal required wake time for the "Wake and Sleep function"	T = 25 °C	--	25.340	43.386	μs
					--	25.065	61.280	μs
		ACMP2L, ACMP3L Start Time		T = 25 °C	--	133.910	267.936	μs
					--	138.254	358.760	μs
V _{HYS}	ACMP0H, ACMP1H Built-in Hysteresis	V _{HYS} = 32 mV	T = 25 °C	21.287	--	39.111	mV	
		V _{HYS} = 64 mV	T = 25 °C	53.756	--	71.486	mV	
		V _{HYS} = 192 mV	T = 25 °C	182.832	--	199.421	mV	
		V _{HYS} = 32 mV		20.837	--	39.552	mV	
		V _{HYS} = 64 mV		52.266	--	71.486	mV	
		V _{HYS} = 192 mV		181.522	--	199.621	mV	
	ACMP2L, ACMP3L Built-in Hysteresis	V _{HYS} = 32 mV	T = 25 °C	23.977	--	39.375	mV	
		V _{HYS} = 64 mV	T = 25 °C	57.066	--	72.087	mV	
		V _{HYS} = 192 mV	T = 25 °C	184.021	--	200.268	mV	
		V _{HYS} = 32 mV		23.410	--	39.910	mV	
		V _{HYS} = 64 mV		55.246	--	72.207	mV	
		V _{HYS} = 192 mV		183.259	--	200.645	mV	
R _{sin}	Input Resistance	Gain = 1x		--	100.0	--	MΩ	
		Gain = 0.5x		--	2.0	--	MΩ	
		Gain = 0.33x		--	2.0	--	MΩ	
		Gain = 0.25x		--	2.0	--	MΩ	
PROP	Propagation Delay, Response Time for ACMP0H, ACMP1H	Gain = 1, V _{ref} = 32 mV to 2016 mV, Overdrive = 10 mV	Low to High	--	1.622	2.708	μs	
			High to Low	--	2.319	4.505	μs	
		Gain = 1, V _{ref} = 32 mV to 2016 mV, Overdrive = 100 mV	Low to High	--	0.527	1.179	μs	
			High to Low	--	0.530	0.968	μs	
		Gain = 1, T = 25 °C, V _{ref} = 32 mV, Overdrive = 10 mV	Low to High	--	1.521	--	μs	
			High to Low	--	1.744	--	μs	

SLG46827-A

Auto AEC-Q100 Qualified GreenPAK Programmable Mixed-Signal Matrix with In-System Debug

Table 17: ACMP Specifications at T = -40 °C to +105 °C, V_{DD} = 2.3 V to 5.5 V Unless Otherwise Noted(Continued)

Parameter	Description	Note	Condition	Min	Typ	Max	Unit
PROP	Propagation Delay, Response Time for ACMP0H, ACMP1H	Gain = 0.5, T = 25 °C, Vref = 32 mV, Overdrive = 10 mV	Low to High	--	2.268	--	μs
			High to Low	--	2.089	--	μs
		Gain = 0.33, T = 25 °C, Vref = 32 mV, Overdrive = 10 mV	Low to High	--	2.156	--	μs
			High to Low	--	1.979	--	μs
		Gain = 0.25, T = 25 °C, Vref = 32 mV, Overdrive = 10 mV	Low to High	--	2.037	--	μs
			High to Low	--	1.856	--	μs
		Gain = 1, T = 25 °C, Vref = 32 mV, Overdrive = 100 mV	Low to High	--	0.567	--	μs
			High to Low	--	0.783	--	μs
		Gain = 0.5, T = 25 °C, Vref = 32 mV, Overdrive = 100 mV	Low to High	--	0.752	--	μs
			High to Low	--	0.700	--	μs
		Gain = 0.33, T = 25 °C, Vref = 32 mV, Overdrive = 100 mV	Low to High	--	0.738	--	μs
			High to Low	--	0.690	--	μs
		Gain = 0.25, T = 25 °C, Vref = 32 mV, Overdrive = 100 mV	Low to High	--	0.715	--	μs
			High to Low	--	0.670	--	μs
PROP	Propagation Delay, Response Time for ACMP2L, ACMP3L	Gain = 1, Vref = 32 mV to 2016 mV, Overdrive = 10 mV	Low to High	--	47.879	88.052	μs
			High to Low	--	54.803	109.606	μs
		Gain = 1, Vref = 32 mV to 2016 mV, Overdrive = 100 mV	Low to High	--	18.008	38.364	μs
			High to Low	--	17.701	38.578	μs
		Gain = 1, T = 25 °C, Vref = 32 mV, Overdrive = 10 mV	Low to High	--	70.241	--	μs
			High to Low	--	66.944	--	μs
		Gain = 0.5, T = 25 °C, Vref = 32 mV, Overdrive = 10 mV	Low to High	--	61.681	--	μs
			High to Low	--	52.956	--	μs
		Gain = 0.33, T = 25 °C, Vref = 32 mV, Overdrive = 10 mV	Low to High	--	60.891	--	μs
			High to Low	--	52.603	--	μs
		Gain = 0.25, T = 25 °C, Vref = 32 mV, Overdrive = 10 mV	Low to High	--	61.228	--	μs
			High to Low	--	52.796	--	μs
		Gain = 1, T = 25 °C, Vref = 32 mV, Overdrive = 100 mV	Low to High	--	28.322	--	μs
			High to Low	--	41.648	--	μs
		Gain = 0.5, T = 25 °C, Vref = 32 mV, Overdrive = 100 mV	Low to High	--	25.301	--	μs
			High to Low	--	24.212	--	μs
		Gain = 0.33, T = 25 °C, Vref = 32 mV, Overdrive = 100 mV	Low to High	--	25.022	--	μs
			High to Low	--	24.124	--	μs
Gain = 0.25, T = 25 °C, Vref = 32 mV, Overdrive = 100 mV	Low to High	--	24.937	--	μs		
	High to Low	--	24.097	--	μs		

SLG46827-A

Auto AEC-Q100 Qualified GreenPAK Programmable Mixed-Signal Matrix with In-System Debug

Table 17: ACMP Specifications at T = -40 °C to +105 °C, V_{DD} = 2.3 V to 5.5 V Unless Otherwise Noted(Continued)

Parameter	Description	Note	Condition	Min	Typ	Max	Unit
G	Gain error (including threshold and internal Vref error)	G = 1		--	1	--	
		G = 0.5		0.446	0.501	0.544	
		G = 0.33		0.302	0.335	0.363	
		G = 0.25		0.227	0.251	0.272	
Vref0 _{accuracy}	Internal Vref0 error, Vref0 = 32 mV to 2016 mV	V _{DD} = 4.0 V	T = 25 °C	-2.47	--	0.63	%
	Vref0 Output error, Vref0 = 224 mV to 992 mV, Buffer Enabled	Loading = 1 μA	T = 25 °C	-11.92	--	5.17	%
	Vref0 Output error, Vref0 = 992 mV to 2016 mV, Buffer Enabled		T = 25 °C	-14.61	--	5.18	%
	Vref0 Output error, Vref0 = 32 mV to 2016 mV, Buffer Enabled		T = 25 °C	-0.74	--	0.76	%
Vref0 Output error, Vref0 = 992 mV to 2016 mV, Buffer Enabled	T = 25 °C		-1.62	--	1.27	%	
C _{VREF0}	Vref0 Output Capacitance Loading		T = 25 °C, Loading = 1 μA	--	--	5	pF
			Load Resistance = 560 kΩ	--	--	10	pF
			Load Resistance = 100 kΩ	--	--	40	pF
			Load Resistance = 10 kΩ	--	--	80	pF
			Load Resistance = 2 kΩ	--	--	120	pF
			Load Resistance = 1 kΩ, Vref = 32 mV to 1024 mV	--	--	150	pF
Vref1 _{accuracy}	Internal Vref1 error, Vref1 = 32 mV to 2016 mV	V _{DD} = 4.0 V	T = 25 °C	-2.86	--	1.48	%
	Vref1 Output error, Vref1 = 224 mV to 992 mV, Buffer Enabled	Loading = 1 μA	T = 25 °C	-11.22	--	4.59	%
	Vref1 Output error, Vref1 = 992 mV to 2016 mV, Buffer Enabled		T = 25 °C	-12.73	--	4.59	%
	Vref1 Output error, Vref1 = 32 mV to 2016 mV, Buffer Enabled		T = 25 °C	-0.82	--	0.78	%
Vref1 Output error, Vref1 = 992 mV to 2016 mV, Buffer Enabled	T = 25 °C		-1.51	--	1.02	%	

SLG46827-A

Auto AEC-Q100 Qualified GreenPAK Programmable Mixed-Signal Matrix with In-System Debug

Table 17: ACMP Specifications at T = -40 °C to +105 °C, V_{DD} = 2.3 V to 5.5 V Unless Otherwise Noted(Continued)

Parameter	Description	Note	Condition	Min	Typ	Max	Unit
C _{VREF1}	Vref1 Output Capacitance Loading		Load Resistance = 1 MΩ	--	--	15	pF
			Load Resistance = 560 kΩ	--	--	27	pF
			Load Resistance = 100 kΩ	--	--	64	pF
			Load Resistance = 10 kΩ	--	--	120	pF
			Load Resistance = 2 kΩ	--	--	180	pF
			Load Resistance = 1 kΩ, Vref = 32 mV to 1024 mV	--	--	210	pF
I _s	Input Current Source		V _{DD} = 2.3 V, V _{IN} = V _{DD} - 0.7 V	22.567	104.679	139.873	μA
			V _{DD} = 3.3 V, V _{IN} = V _{DD} - 0.7 V	66.853	104.512	126.130	μA
			V _{DD} = 5.5 V, V _{IN} = V _{DD} - 0.7 V	69.223	109.215	142.554	μA

3.8 ANALOG TEMPERATURE SENSOR CHARACTERISTICS

Temperature Sensor typical nonlinearity ±2.74% for output range 1 and ±2.69% for output range 2 at V_{DD} = 3.3 V.

Table 18: TS Output vs Temperature (Output Range 1)

T, °C	V _{DD} = 2.3 V		V _{DD} = 3.3 V		V _{DD} = 5.5 V	
	Typical, mV	Accuracy, %	Typical, mV	Accuracy, %	Typical, mV	Accuracy, %
-40	997	±1.59	995	±1.52	995	±1.49
-30	975	±1.64	973	±1.58	973	±1.57
-20	952	±1.63	950	±1.61	951	±1.55
-10	930	±1.55	928	±1.54	929	±1.56
0	907	±1.58	905	±1.59	905	±1.73
10	884	±1.57	882	±1.59	882	±1.74
20	861	±1.63	860	±1.54	860	±1.70
25	851	±1.56	849	±1.58	849	±1.71
30	837	±1.71	836	±1.6	836	±1.71
40	814	±1.73	812	±1.75	813	±1.71
50	790	±1.89	789	±1.78	789	±1.85
60	767	±1.84	765	±1.85	766	±1.79
70	743	±1.85	741	±1.89	741	±2.00
80	719	±2.23	717	±2.30	717	±2.43
90	694	±2.03	693	±1.89	693	±2.08
100	671	±2.00	669	±1.98	670	±1.96
105	659	±2.07	657	±1.06	658	±1.98

SLG46827-A

Auto AEC-Q100 Qualified GreenPAK Programmable Mixed-Signal Matrix with In-System Debug

Table 19: TS Output vs Temperature (Output Range 2)

T, °C	V _{DD} = 2.3 V		V _{DD} = 3.3 V		V _{DD} = 5.5 V	
	Typical, mV	Accuracy, %	Typical, mV	Accuracy, %	Typical, mV	Accuracy, %
-40	1205	±1.67	1202	±1.42	1202	±1.38
-30	1178	±2.09	1175	±1.44	1175	±1.43
-20	1151	±2.59	1148	±1.51	1148	±1.54
-10	1124	±2.21	1121	±1.49	1122	±1.53
0	1096	±1.80	1094	±1.50	1094	±1.65
10	1068	±1.72	1066	±1.59	1067	±1.63
20	1041	±1.61	1039	±1.52	1039	±1.68
25	1027	±1.70	1025	±1.62	1026	±1.63
30	1012	±1.71	1010	±1.66	1010	±1.73
40	984	±1.71	982	±1.65	982	±1.74
50	955	±1.84	953	±1.81	954	±1.77
60	927	±1.85	925	±1.80	926	±1.75
70	897	±1.82	895	±1.80	895	±1.92
80	868	±2.14	866	±2.14	866	±2.28
90	839	±1.94	837	±1.88	837	±1.99
100	810	±2.06	808	±1.99	809	±1.94
105	796	±2.05	793	±2.11	794	±2.04

Table 20: TS Output Error (Output Range 1)

V _{DD} , V	Error at T								
	-40 °C, %	-20 °C, %	0 °C, %	20 °C, %	40 °C, %	60 °C, %	80 °C, %	100 °C, %	105 °C, %
2.30	1.59	1.63	1.58	1.63	1.73	1.84	2.23	2.00	2.07
3.30	1.52	1.61	1.59	1.54	1.75	1.85	2.30	1.98	2.06
4.00	1.48	1.57	1.55	1.50	1.71	1.79	2.42	1.93	2.00
5.50	1.49	1.55	1.73	1.70	1.71	1.79	2.43	1.96	1.98

Table 21: TS Output Error (Output Range 2)

V _{DD} , V	Error at T								
	-40 °C, %	-20 °C, %	0 °C, %	20 °C, %	40 °C, %	60 °C, %	80 °C, %	100 °C, %	105 °C, %
2.30	1.67	2.59	1.80	1.61	1.71	1.85	2.14	2.06	2.05
3.30	1.42	1.51	1.50	1.52	1.65	1.80	2.14	1.99	2.11
4.00	1.46	1.54	1.58	1.60	1.71	1.76	2.22	2.07	2.06
5.50	1.38	1.54	1.65	1.68	1.74	1.75	2.28	1.94	2.04

SLG46827-A

Auto AEC-Q100 Qualified GreenPAK Programmable Mixed-Signal Matrix with In-System Debug

4 In-System Debug

In the development phase, the SLG46827-A is a user programmable device with Multiple-Time-Programmable (MTP) memory elements that are able to configure the connection matrix and macrocells. A programming development kit allows the user the ability to create initial devices. Once the design is finalized, the programming code (.gpx file) is forwarded to Renesas Electronics Corporation to integrate into a production process. At this point, software write protection will be permanently set and the In-System debug feature will no longer be available to the user.

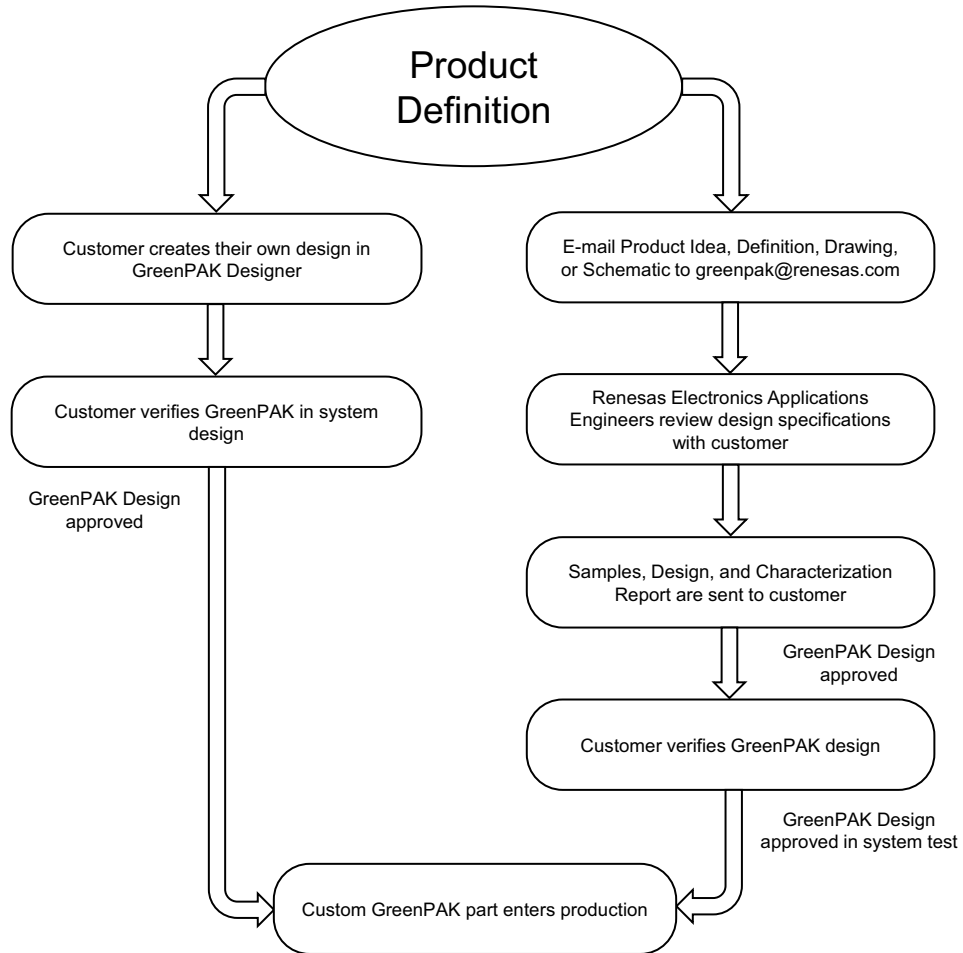

Figure 2: Steps to Create a Custom GreenPAK Device

SLG46827-A

Auto AEC-Q100 Qualified GreenPAK Programmable Mixed-Signal Matrix with In-System Debug

5 IO Pins

5.1 IO PINS

The SLG46827-A has a total of 13 GPIO, 2 GPO, and 2 GPI Pins which can function as either a user defined Input or Output, as well as serving as a special function (such as outputting the voltage reference).

5.2 GPIO PINS

IO0, IO1, IO2, IO3, IO4, IO5, IO8, IO9, IO10, IO11, IO12, IO13, IO14 serve as General Purpose IO Pins.

5.3 GPO PINS

IO6 and IO7 serve as General Purpose Output Pins.

5.4 GPI PINS

SCL and SDA serve as General Purpose Input Pins.

5.5 PULL-UP/DOWN RESISTORS

All IO Pins have the option of user-selectable resistors that can be connected to the pin structure. The selectable values on these resistors are 10 k Ω , 100 k Ω , and 1 M Ω . The internal resistors can be configured as either Pull-up or Pull-downs.

5.6 FAST PULL-UP/DOWN DURING POWER-UP

During power-up, IO pull-up/down resistance will switch to 2.6 k Ω initially and then it will switch to normal setting value. This function is enabled by register [768].

SLG46827-A

Auto AEC-Q100 Qualified GreenPAK
Programmable Mixed-Signal Matrix with In-System Debug

5.7 I²C MODE IO STRUCTURE (V_{DD} OR V_{DD2})

5.7.1 I²C Mode Structure (for SCL and SDA)

Input Mode [1:0]
 00: Digital In without Schmitt Trigger, wosmt_en = 1
 01: Digital In with Schmitt Trigger, smt_en = 1
 10: Low Voltage Digital In mode 1, lv_en = 1
 11: Reserved

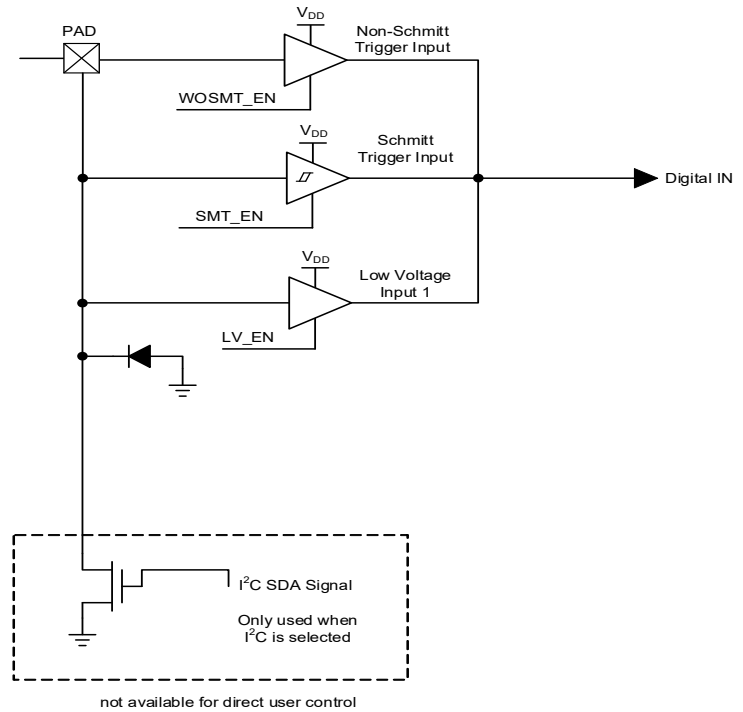

Figure 3: IO with I²C Mode IO Structure Diagram

SLG46827-A

Auto AEC-Q100 Qualified GreenPAK Programmable Mixed-Signal Matrix with In-System Debug

5.8 MATRIX OE IO STRUCTURE (V_{DD} OR V_{DD2})

5.8.1 Matrix OE IO Structure (for IOs 1, 4, 5 with V_{DD} , and IOs 8, 9, 10, 11, 12, 13, 14 with V_{DD2})

Input Mode [1:0]
 00: Digital In without Schmitt Trigger, wosmt_en = 1
 01: Digital In with Schmitt Trigger, smt_en = 1
 10: Low Voltage Digital In mode, lv_en = 1
 11: analog IO mode

Output Mode [1:0]
 00: Push-Pull 1x mode, pp1x_en = 1
 01: Push-Pull 2x mode, pp2x_en = 1, pp1x_en = 1
 10: NMOS 1x Open-Drain mode, od1x_en = 1
 11: NMOS 2x Open-Drain mode, od2x_en = 1, od1x_en = 1

Note 1: Digital Out and OE are Matrix Output, Digital In is Matrix Input
 Note 2: Can be varied over PVT, for reference only.

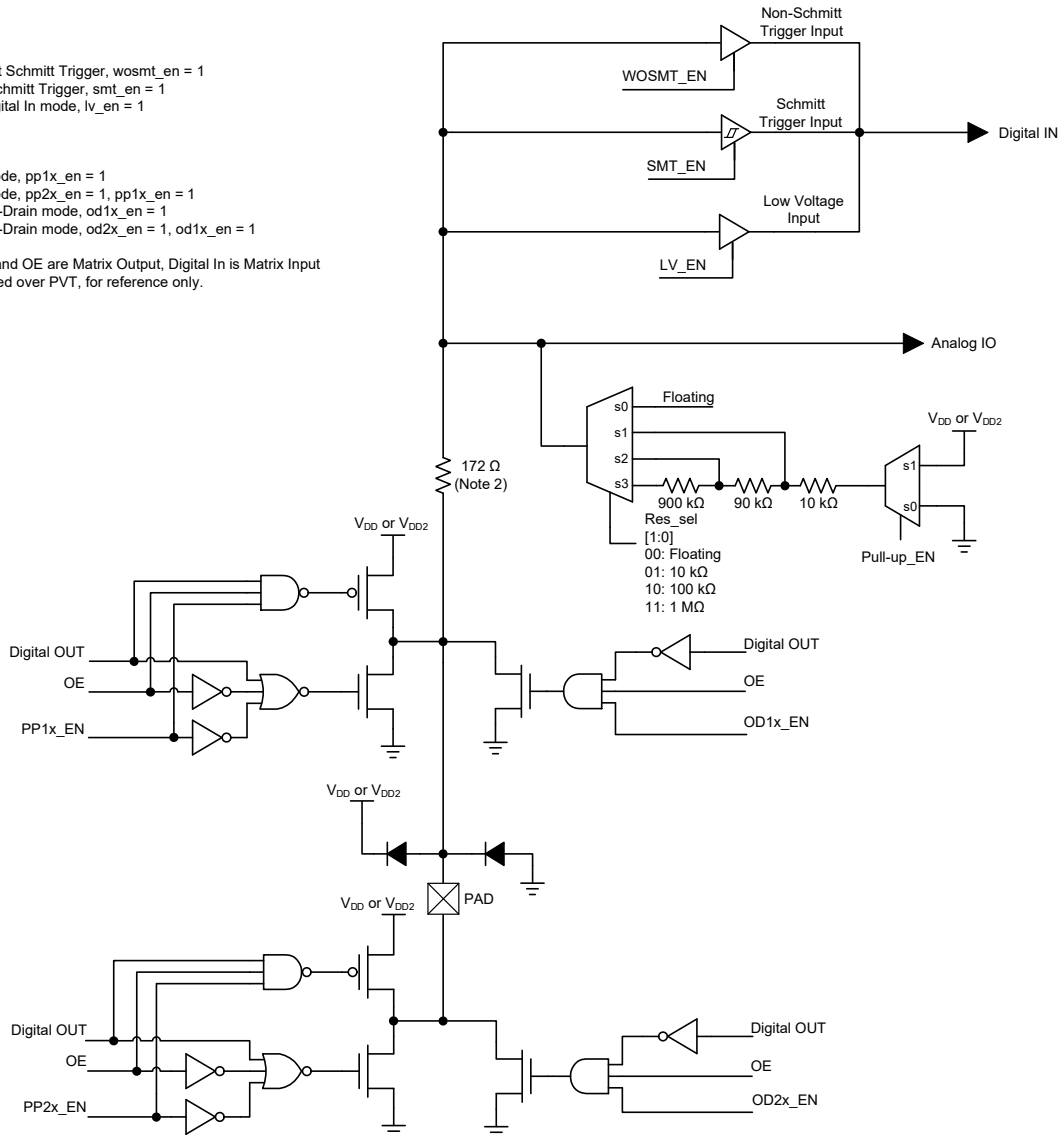

Figure 4: Matrix OE IO Structure Diagram

SLG46827-A

Auto AEC-Q100 Qualified GreenPAK Programmable Mixed-Signal Matrix with In-System Debug

5.9 REGISTER OE IO STRUCTURE (V_{DD} OR V_{DD2})

5.9.1 Register OE IO Structure (for IOs 0, 2, 3 with V_{DD})

Input Mode [1:0]
 00: Digital In without Schmitt Trigger, wosmt_en = 1, OE = 0
 01: Digital In with Schmitt Trigger, smt_en = 1, OE = 0
 10: Low Voltage Digital In mode, lv_en = 1, OE = 0
 11: Reserved

Output Mode [1:0]
 00: Push-Pull 1x mode, pp1x_en = 1, OE = 1
 01: Push-Pull 2x mode, pp2x_en = 1, OE = 1
 10: 1x Open-Drain mode, od1x_en = 1, OE = 1
 11: 2x Open-Drain mode, od2x_en = 1, OE = 1

Note 1: OE cannot be selected by user and is controlled by register
 Note 2: Can be varied over PVT, for reference only

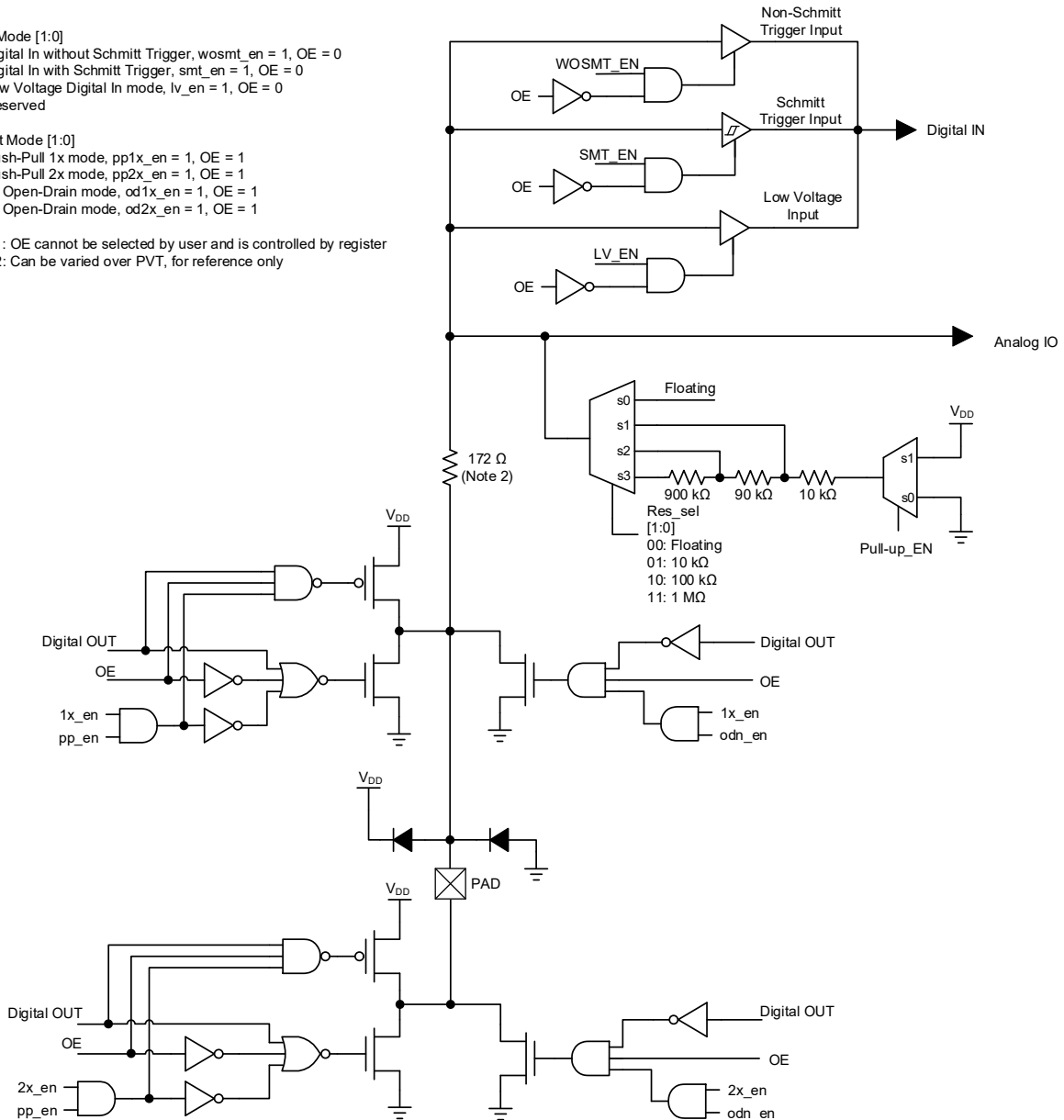

Figure 5: GPIO Register OE IO Structure Diagram

SLG46827-A

Auto AEC-Q100 Qualified GreenPAK
Programmable Mixed-Signal Matrix with In-System Debug

5.10 REGISTER OE IO STRUCTURE (V_{DD} OR V_{DD2})

5.10.1 Register OE IO Structure (for IO 6 with V_{DD} , and IO 7 with V_{DD2})

Mode [2:0]
 000: Reserved
 001: Reserved
 010: Reserved
 011: Reserved
 100: Push-Pull mode, pp_en = 1, OE = 1
 101: NMOS Open-Drain mode, odn_en = 1, OE = 1
 110: PMOS Open-Drain mode, odp_en = 1, OE = 1
 111: analog IO and NMOS Open-Drain mode, odn_en = 1 and aio_en=1

Note: OE cannot be selected by user and is controlled by register

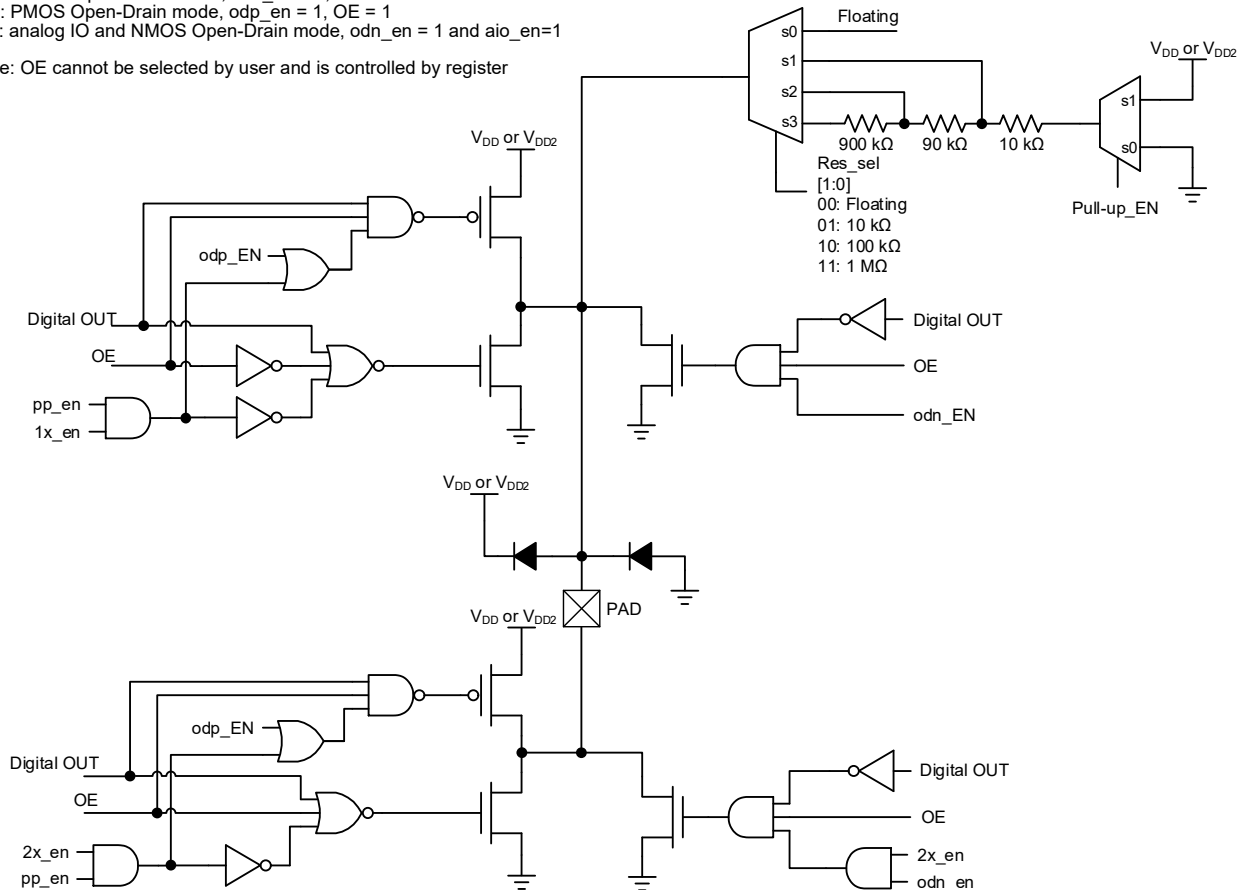

Figure 6: GPIO Register OE IO Structure Diagram

SLG46827-A

Auto AEC-Q100 Qualified GreenPAK
Programmable Mixed-Signal Matrix with In-System Debug

5.11 IO TYPICAL PERFORMANCE

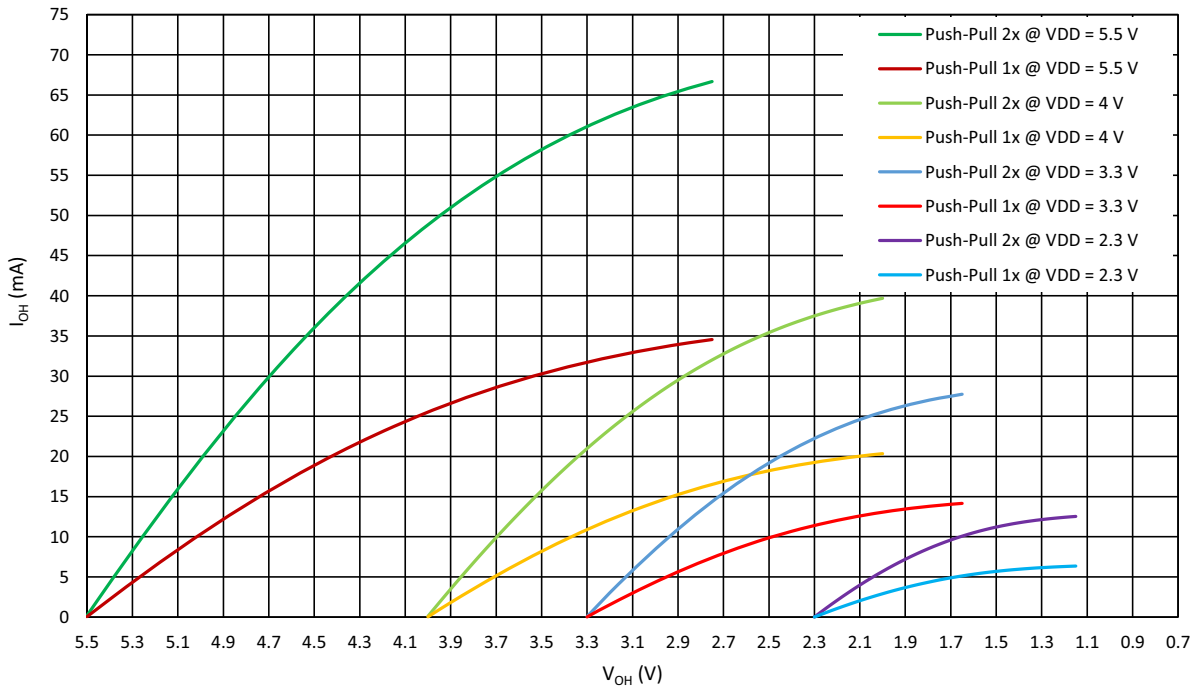

Figure 7: Typical High Level Output Current vs. High Level Output Voltage

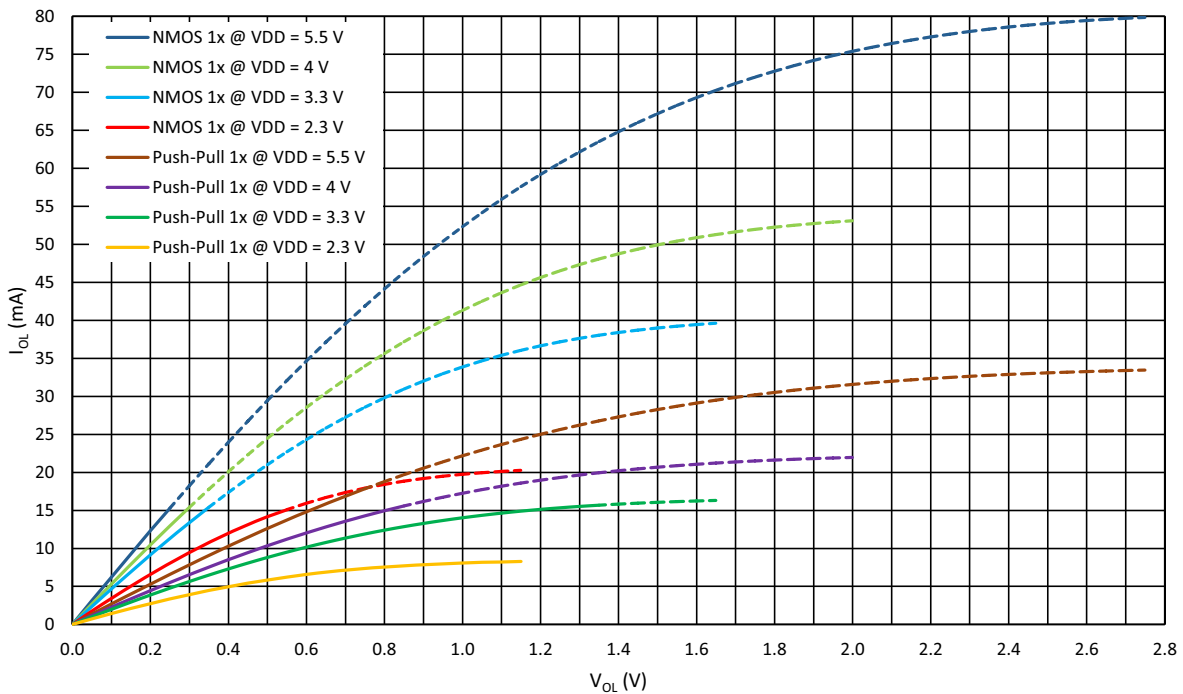

Figure 8: Typical Low Level Output Current vs. Low Level Output Voltage (for 1x Drive)

SLG46827-A

Auto AEC-Q100 Qualified GreenPAK
Programmable Mixed-Signal Matrix with In-System Debug

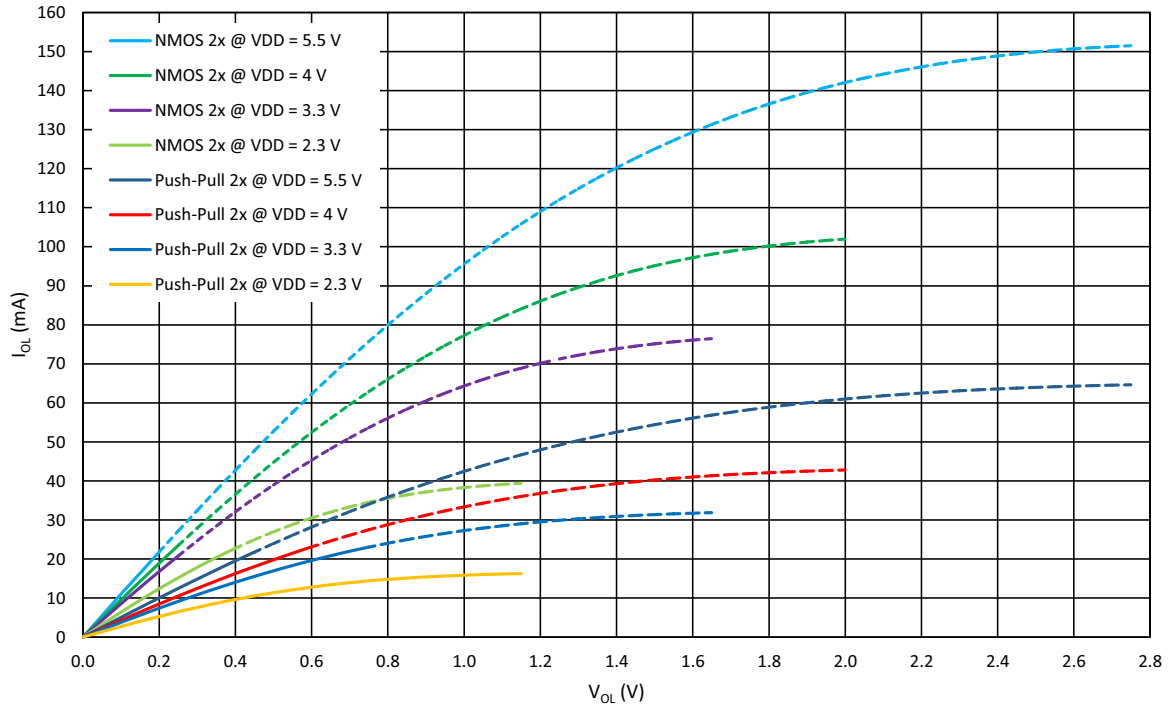

Figure 9: Typical Low Level Output Current vs. Low Level Output Voltage (for 2x Drive)

SLG46827-A

Auto AEC-Q100 Qualified GreenPAK
Programmable Mixed-Signal Matrix with In-System Debug

6 Connection Matrix

The Connection Matrix in the SLG46827-A is used to create the internal routing for internal functional macrocells of the device once it is programmed. The registers are programmed from the multiple-time NVM cell during Test Mode Operation. The output of each functional macrocell within the SLG46827-A has a specific digital bit code assigned to it that is either set to active “High” or inactive “Low”, based on the design that is created. Once the 2048 register bits within the SLG46827-A are programmed a fully custom circuit will be created.

The Connection Matrix has 64 inputs and 96 outputs. Each of the 64 inputs to the Connection Matrix is hard-wired to the digital output of a particular source macrocell, including IOs, LUTs, analog comparators, other digital resources, such as V_{DD} and GND. The input to a digital macrocell uses a 6-bit register to select one of these 64 input lines.

For a complete list of the SLG46827-A’s register table, see Section 18.

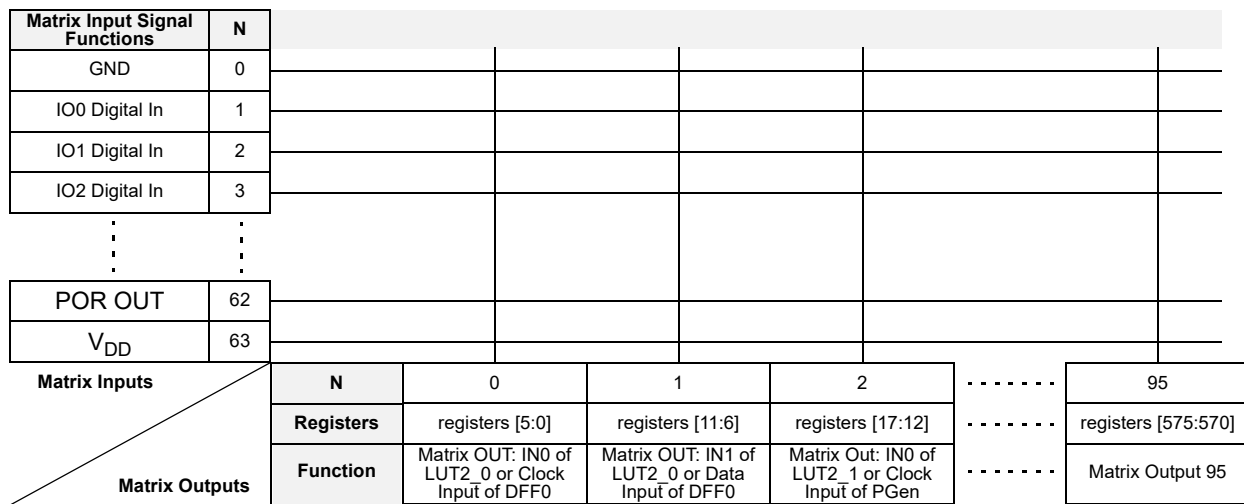

Figure 10: Connection Matrix

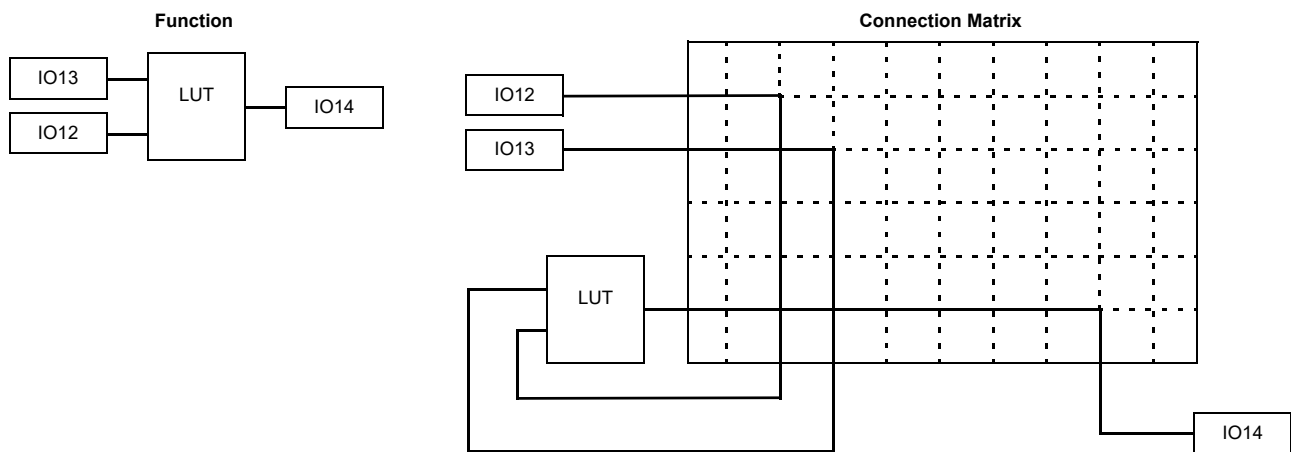

Figure 11: Connection Matrix Example

SLG46827-A

Auto AEC-Q100 Qualified GreenPAK Programmable Mixed-Signal Matrix with In-System Debug

6.1 MATRIX INPUT TABLE

Table 22: Matrix Input Table

Matrix Input Number	Matrix Input Signal Function	Matrix Decode					
		5	4	3	2	1	0
0	GND	0	0	0	0	0	0
1	IO0 Digital Input	0	0	0	0	0	1
2	IO1 Digital Input	0	0	0	0	1	0
3	IO2 Digital Input	0	0	0	0	1	1
4	IO3 Digital Input	0	0	0	1	0	0
5	IO4 Digital Input	0	0	0	1	0	1
6	IO5 Digital Input	0	0	0	1	1	0
7	IO8 Digital Input	0	0	0	1	1	1
8	IO9 Digital Input	0	0	1	0	0	0
9	IO10 Digital Input	0	0	1	0	0	1
10	IO11 Digital Input	0	0	1	0	1	0
11	IO12 Digital Input	0	0	1	0	1	1
12	IO13 Digital Input	0	0	1	1	0	0
13	IO14 Digital Input	0	0	1	1	0	1
14	LUT2_0_DFF0_OUT	0	0	1	1	1	0
15	LUT2_1_DFF1_OUT	0	0	1	1	1	1
16	LUT2_2_DFF2_OUT	0	1	0	0	0	0
17	LUT2_3_PGEN_OUT	0	1	0	0	0	1
18	LUT3_0_DFF3_OUT	0	1	0	0	1	0
19	LUT3_1_DFF4_OUT	0	1	0	0	1	1
20	LUT3_2_DFF5_OUT	0	1	0	1	0	0
21	LUT3_3_DFF6_OUT	0	1	0	1	0	1
22	LUT3_4_DFF7_OUT	0	1	0	1	1	0
23	LUT3_5_DFF8_OUT	0	1	0	1	1	1
24	LUT3_6_PIPEDLY_RIPP_CNT_OUT0	0	1	1	0	0	0
25	PIPEDLY_RIPP_CNT_OUT1	0	1	1	0	0	1
26	RIPP_CNT_OUT2	0	1	1	0	1	0
27	EDET_FILTER_OUT	0	1	1	0	1	1
28	PROG_DLY_EDET_OUT	0	1	1	1	0	0
29	MULTFUNC_8BIT_1: DLY_CNT_OUT	0	1	1	1	0	1
30	CKOSC1_MATRIX: OSC1 matrix input	0	1	1	1	1	0
31	CKOSC0_MATRIX: OSC0 matrix input	0	1	1	1	1	1
32	CKOSC2_MATRIX: OSC2 matrix input	1	0	0	0	0	0
33	MULTFUNC_8BIT_2: DLY_CNT_OUT	1	0	0	0	0	1
34	MULTFUNC_8BIT_3: DLY_CNT_OUT	1	0	0	0	1	0
35	MULTFUNC_8BIT_4: DLY_CNT_OUT	1	0	0	0	1	1
36	MULTFUNC_8BIT_5: DLY_CNT_OUT	1	0	0	1	0	0
37	MULTFUNC_8BIT_6: DLY_CNT_OUT	1	0	0	1	0	1

SLG46827-A

Auto AEC-Q100 Qualified GreenPAK Programmable Mixed-Signal Matrix with In-System Debug

Table 22: Matrix Input Table(Continued)

Matrix Input Number	Matrix Input Signal Function	Matrix Decode					
		5	4	3	2	1	0
38	MULTFUNC_8BIT_7: DLY_CNT_OUT	1	0	0	1	1	0
39	MULTFUNC_16BIT_0: LUT_DFF_OUT	1	0	0	1	1	1
40	MULTFUNC_8BIT_1: LUT_DFF_OUT	1	0	1	0	0	0
41	MULTFUNC_8BIT_2: LUT_DFF_OUT	1	0	1	0	0	1
42	MULTFUNC_8BIT_3: LUT_DFF_OUT	1	0	1	0	1	0
43	MULTFUNC_8BIT_4: LUT_DFF_OUT	1	0	1	0	1	1
44	MULTFUNC_8BIT_5: LUT_DFF_OUT	1	0	1	1	0	0
45	MULTFUNC_8BIT_6: LUT_DFF_OUT	1	0	1	1	0	1
46	MULTFUNC_8BIT_7: LUT_DFF_OUT	1	0	1	1	1	0
47	MULTFUNC_16BIT_0: DLY_CNT_OUT	1	0	1	1	1	1
48	I ² C_virtual_7 Input: register [976]	1	1	0	0	0	0
49	I ² C_virtual_6 Input: register [977]	1	1	0	0	0	1
50	I ² C_virtual_5 Input: register [978]	1	1	0	0	1	0
51	I ² C_virtual_4 Input: register [979]	1	1	0	0	1	1
52	I ² C_virtual_3 Input: register [980]	1	1	0	1	0	0
53	I ² C_virtual_2 Input: register [981]	1	1	0	1	0	1
54	I ² C_virtual_1 Input: register [982]	1	1	0	1	1	0
55	I ² C_virtual_0 Input: register [983]	1	1	0	1	1	1
56	ACMP0H_OUT	1	1	1	0	0	0
57	ACMP1H_OUT	1	1	1	0	0	1
58	ACMP2L_OUT	1	1	1	0	1	0
59	ACMP3L_OUT	1	1	1	0	1	1
60	2nd CKOSC1_MATRIX	1	1	1	1	0	0
61	2nd CKOSC0_MATRIX	1	1	1	1	0	1
62	POR OUT	1	1	1	1	1	0
63	V _{DD}	1	1	1	1	1	1

6.2 MATRIX OUTPUT TABLE

Table 23: Matrix Output Table

Register Bit Address	Matrix Output Signal Function	Matrix Output Number
[5:0]	IN0 of LUT2_0 or Clock Input of DFF0	0
[11:6]	IN1 of LUT2_0 or Data Input of DFF0	1
[17:12]	IN0 of LUT2_3 or Clock Input of PGen	2
[23:18]	IN1 of LUT2_3 or nRST of PGen	3
[29:24]	IN0 of LUT2_1 or Clock Input of DFF1	4
[35:30]	IN1 of LUT2_1 or Data Input of DFF1	5
[41:36]	IN0 of LUT2_2 or Clock Input of DFF2	6
[47:42]	IN1 of LUT2_2 or Data Input of DFF2	7
[53:48]	IN0 of LUT3_0 or Clock Input of DFF3	8

SLG46827-A

Auto AEC-Q100 Qualified GreenPAK Programmable Mixed-Signal Matrix with In-System Debug

Table 23: Matrix Output Table(Continued)

Register Bit Address	Matrix Output Signal Function	Matrix Output Number
[59:54]	IN1 of LUT3_0 or Data Input of DFF3	9
[65:60]	IN2 of LUT3_0 or nRST(nSET) of DFF3	10
[71:66]	IN0 of LUT3_1 or Clock Input of DFF4	11
[77:72]	IN1 of LUT3_1 or Data Input of DFF4	12
[83:78]	IN2 of LUT3_1 or nRST(nSET) of DFF4	13
[89:84]	IN0 of LUT3_2 or Clock Input of DFF5	14
[95:90]	IN1 of LUT3_2 or Data Input of DFF5	15
[101:96]	IN2 of LUT3_2 or nRST(nSET) of DFF5	16
[107:102]	IN0 of LUT3_3 or Clock Input of DFF6	17
[113:108]	IN1 of LUT3_3 or Data Input of DFF6	18
[119:114]	IN2 of LUT3_3 or nRST(nSET) of DFF6	19
[125:120]	IN0 of LUT3_4 or Clock Input of DFF7	20
[131:126]	IN1 of LUT3_4 or Data Input of DFF7	21
[137:132]	IN2 of LUT3_4 or nRST(nSET) of DFF7	22
[143:138]	IN0 of LUT3_5 or Clock Input of DFF8	23
[149:144]	IN1 of LUT3_5 or Data Input of DFF8	24
[155:150]	IN2 of LUT3_5 or nRST(nSET) of DFF8	25
[161:156]	IN0 of LUT3_6 or Input of Pipe Delay or UP Signal of RIPP CNT	26
[167:162]	IN1 of LUT3_6 or nRST of Pipe Delay or STB of RIPP CNT	27
[173:168]	IN2 of LUT3_6 or Clock of Pipe Delay_RIPP_CNT	28
[179:174]	Reserved	29
[185:180]	MULTFUNC_16BIT_0: IN0 of LUT4_0 or Clock Input of DFF9; Delay0 Input (or Counter0 RST/SET Input)	30
[191:186]	MULTFUNC_16BIT_0: IN1 of LUT4_0 or nRST of DFF9; Delay0 Input (or Counter0 nRST Input) or Delay/Counter0 External Clock Source	31
[197:192]	MULTFUNC_16BIT_0: IN2 of LUT4_0 or nSET of DFF9 or KEEP Input of FSM0 or External Clock Input of Delay0 (or Counter0)	32
[203:198]	MULTFUNC_16BIT_0: IN3 of LUT4_0 or Data Input of DFF9; Delay0 Input (or Counter0 nRST Input) or UP Input of FSM0	33
[209:204]	MULTFUNC_8BIT_1: IN0 of LUT3_7 or Clock Input of DFF10; Delay1 Input (or Counter1 nRST Input)	34
[215:210]	MULTFUNC_8BIT_1: IN1 of LUT3_7 or nRST (nSET) of DFF10; Delay1 Input (or Counter1 nRST Input) or Delay/Counter1 External Clock Source	35
[221:216]	MULTFUNC_8BIT_1: IN2 of LUT3_7 or Data Input of DFF10; Delay1 Input (or Counter1 nRST Input)	36
[227:222]	MULTFUNC_8BIT_2: IN0 of LUT3_8 or Clock Input of DFF11; Delay2 Input (or Counter2 nRST Input)	37
[233:228]	MULTFUNC_8BIT_2: IN1 of LUT3_8 or nRST (nSET) of DFF11; Delay2 Input (or Counter2 nRST Input) or Delay/Counter2 External Clock Source	38
[239:234]	MULTFUNC_8BIT_2: IN2 of LUT3_8 or Data Input of DFF11; Delay2 Input (or Counter2 nRST Input)	39
[245:240]	MULTFUNC_8BIT_3: IN0 of LUT3_9 or Clock Input of DFF12; Delay3 Input (or Counter3 nRST Input)	40

SLG46827-A

Auto AEC-Q100 Qualified GreenPAK Programmable Mixed-Signal Matrix with In-System Debug

Table 23: Matrix Output Table(Continued)

Register Bit Address	Matrix Output Signal Function	Matrix Output Number
[251:246]	MULTFUNC_8BIT_3: IN1 of LUT3_9 or nRST (nSET) of DFF12; Delay3 Input (or Counter3 nRST Input) or Delay/Counter3 External Clock Source	41
[257:252]	MULTFUNC_8BIT_3: IN2 of LUT3_9 or Data Input of DFF12; Delay3 Input (or Counter3 nRST Input)	42
[263:258]	MULTFUNC_8BIT_4: IN0 of LUT3_10 or Clock Input of DFF13; Delay4 Input (or Counter4 nRST Input)	43
[269:264]	MULTFUNC_8BIT_4: IN1 of LUT3_10 or nRST (nSET) of DFF13; Delay4 Input (or Counter4 nRST Input) or Delay/Counter4 External Clock Source	44
[275:270]	MULTFUNC_8BIT_4: IN2 of LUT3_10 or Data Input of DFF13; Delay4 Input (or Counter4 nRST Input)	45
[281:276]	MULTFUNC_8BIT_5: IN0 of LUT3_11 or Clock Input of DFF14; Delay5 Input (or Counter5 nRST Input)	46
[287:282]	MULTFUNC_8BIT_5: IN1 of LUT3_11 or nRST (nSET) of DFF14; Delay5 Input (or Counter5 nRST Input) or Delay/Counter5 External Clock Source	47
[293:288]	MULTFUNC_8BIT_5: IN2 of LUT3_11 or Data Input of DFF14; Delay5 Input (or Counter5 nRST Input)	48
[299:294]	MULTFUNC_8BIT_6: IN0 of LUT3_12 or Clock Input of DFF15; Delay6 Input (or Counter6 nRST Input)	49
[305:300]	MULTFUNC_8BIT_6: IN1 of LUT3_12 or nRST (nSET) of DFF15; Delay6 Input (or Counter6 nRST Input) or Delay/Counter6 External Clock Source	50
[311:306]	MULTFUNC_8BIT_6: IN2 of LUT3_12 or Data Input of DFF15; Delay6 Input (or Counter6 nRST Input)	51
[317:312]	MULTFUNC_8BIT_7: IN0 of LUT3_13 or Clock Input of DFF16; Delay7 Input (or Counter7 nRST Input)	52
[323:318]	MULTFUNC_8BIT_7: IN1 of LUT3_13 or nRST (nSET) of DFF16; Delay7 Input (or Counter7 nRST Input) or Delay/Counter7 External Clock Source	53
[329:324]	MULTFUNC_8BIT_7: IN2 of LUT3_13 or Data Input of DFF16; Delay7 Input (or Counter7 nRST Input)	54
[335:330]	Filter/Edge detect input	55
[341:336]	Programmable delay/edge detect input	56
[347:342]	OSC2 ENABLE from matrix	57
[353:348]	OSC0 ENABLE from matrix	58
[359:354]	OSC1 ENABLE matrix	59
[365:360]	Temp sensor and Vref PD from matrix	60
[371:366]	BG power-down from matrix	61
[377:372]	PWR UP of ACMP0H from matrix	62
[383:378]	PWR UP of ACMP1H from matrix	63
[389:384]	PWR UP of ACMP2L from matrix	64
[395:390]	PWR UP of ACMP3L from matrix	65
[401:396]	Reserved	66
[407:402]	IO0 Digital Output	67
[413:408]	IO1 Digital Output	68
[419:414]	IO1 Digital Output OE	69
[425:420]	IO2 Digital Output	70

Table 23: Matrix Output Table(Continued)

Register Bit Address	Matrix Output Signal Function	Matrix Output Number
[431:426]	IO3 Digital Output	71
[437:432]	IO4 Digital Output	72
[443:438]	IO4 Digital Output OE	73
[449:444]	IO5 Digital Output	74
[455:450]	IO5 Digital Output OE	75
[461:456]	IO6 Digital Output	76
[467:462]	IO7 Digital Output	77
[473:468]	IO8 Digital Output	78
[479:474]	IO8 Digital Output OE	79
[485:480]	IO9 Digital Output	80
[491:486]	IO9 Digital Output OE	81
[497:492]	IO10 Digital Output	82
[503:498]	IO10 Digital Output OE	83
[509:504]	IO11 Digital Output	84
[515:510]	IO11 Digital Output OE	85
[521:516]	IO12 Digital Output	86
[527:522]	IO12 Digital Output OE	87
[533:528]	IO13 Digital Output	88
[539:534]	IO13 Digital Output OE	89
[545:540]	IO14 Digital Output	90
[551:546]	IO14 Digital Output OE	91
[557:552]	Reserved	92
[563:558]	Reserved	93
[569:564]	Matrix OUT 94	94
[575:570]	Matrix OUT 95	95

Note 1 For each Address, the two most significant bits are unused.

6.3 CONNECTION MATRIX VIRTUAL INPUTS

As mentioned previously, the Connection Matrix inputs come from the outputs of various digital macrocells on the device. Eight of the Connection Matrix inputs have the special characteristic that the state of these signal lines comes from a corresponding data bit written as a register value via I²C. This gives the user the ability to write data via the serial channel, and have this information translated into signals that can be driven into the Connection Matrix and from the Connection Matrix to the digital inputs of other macrocells on the device. The I²C address for reading and writing these register values is at 0x7A (0122).

An I²C write command to these register bits will set the signal values going into the Connection Matrix to the desired state. A read command to these register bits will read either the original data values coming from the NVM memory bits (that were loaded during the initial device startup), or the values from a previous write command (if that has happened).

See [Table 24](#).

Table 24: Connection Matrix Virtual Inputs

Matrix Input Number	Matrix Input Signal Function	Register Bit Addresses (d)
55	I ² C_virtual_0 Input	[983]
54	I ² C_virtual_1 Input	[982]
53	I ² C_virtual_2 Input	[981]
52	I ² C_virtual_3 Input	[980]
51	I ² C_virtual_4 Input	[979]
50	I ² C_virtual_5 Input	[978]
49	I ² C_virtual_6 Input	[977]
48	I ² C_virtual_7 Input	[976]

6.4 CONNECTION MATRIX VIRTUAL OUTPUTS

The digital outputs of the various macrocells are routed to the Connection Matrix to enable interconnections to the inputs of other macrocells in the device. At the same time, it is possible to read the state of each of the macrocell outputs as a register value via I²C. This option, called Connection Matrix Virtual Outputs, allows the user to remotely read the values of each macrocell output. The I²C addresses for reading these register values are 0x74 (0116) to 0x7B (0123). Write commands to these same register values will be ignored (with the exception of the Virtual Input register bits at 0x7A (0122)).

SLG46827-A

Auto AEC-Q100 Qualified GreenPAK
Programmable Mixed-Signal Matrix with In-System Debug

7 Combination Function Macrocells

The SLG46827-A has 11 combination function macrocells that can serve more than one logic or timing function. In each case, they can serve as a Look Up Table (LUT), or as another logic or timing function. See the list below for the functions that can be implemented in these macrocells.

- Three macrocells that can serve as either 2-bit LUT or as D Flip-Flop
- Six macrocells that can serve as either 3-bit LUTs or as D Flip-Flops with Set/Reset Input
- One macrocell that can serve as either 3-bit LUT or as Pipe Delay/Ripple Counter
- One macrocell that can serve as either 2-bit LUT or as Programmable Pattern Generator (PGen)

Inputs/Outputs for the 11 combination function macrocells are configured from the connection matrix with specific logic functions being defined by the state of NVM bits.

When used as a LUT to implement combinatorial logic functions, the outputs of the LUTs can be configured to any user defined function, including the following standard digital logic devices (AND, NAND, OR, NOR, XOR, XNOR).

7.1 2-BIT LUT OR D FLIP-FLOP MACROCELLS

There are three macrocells that can serve as either 2-bit LUT or as D Flip-Flop. When used to implement LUT functions, the 2-bit LUT takes in two input signals from the connection matrix and produce a single output, which goes back into the connection matrix. When used to implement D Flip-Flop function, the two input signals from the connection matrix go to the data (D) and clock (CLK) inputs for the Flip-Flop, with the output going back to the connection matrix.

The operation of the D Flip-Flop and LATCH will follow the functional descriptions below:

DFF: CLK is rising edge triggered, then Q = D; otherwise Q will not change

LATCH: when CLK is Low, then Q = D; otherwise Q remains its previous value (input D has no effect on the output, when CLK is High).

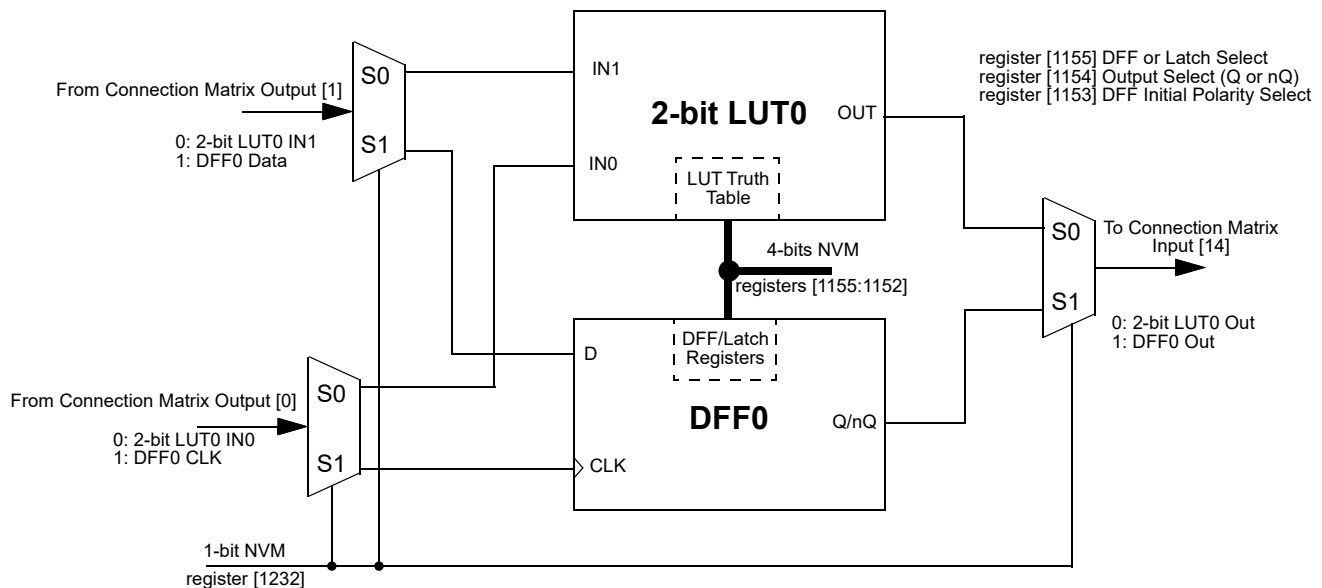

Figure 12: 2-bit LUT0 or DFF0

SLG46827-A

Auto AEC-Q100 Qualified GreenPAK
Programmable Mixed-Signal Matrix with In-System Debug

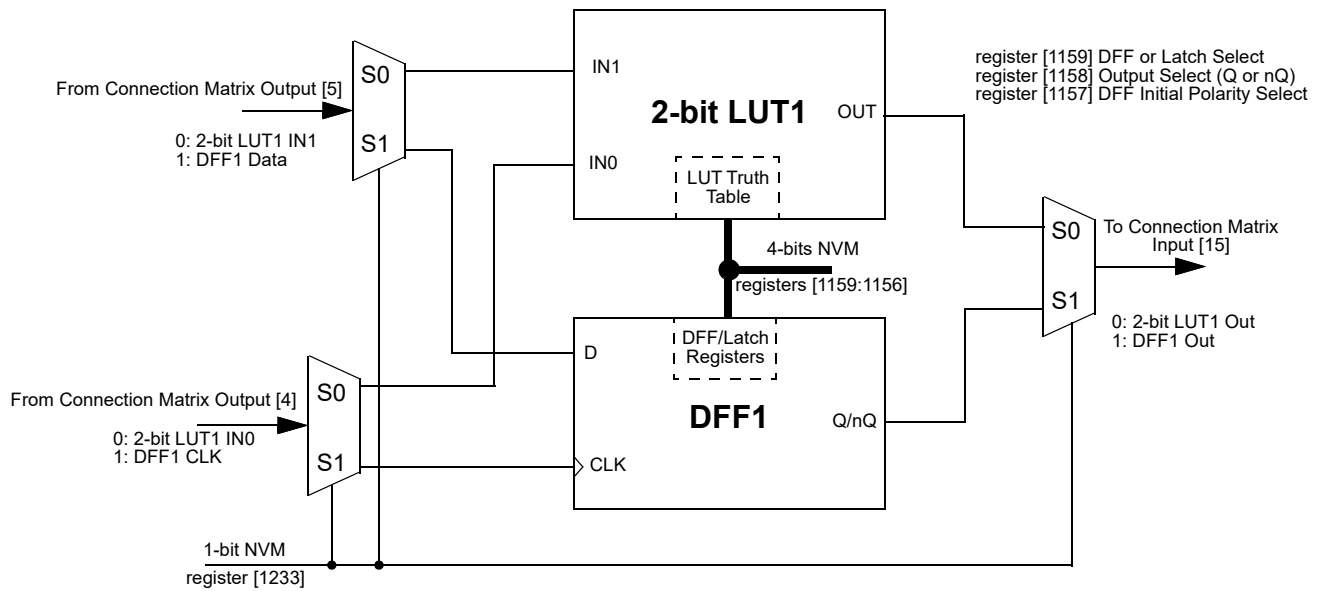

Figure 13: 2-bit LUT1 or DFF1

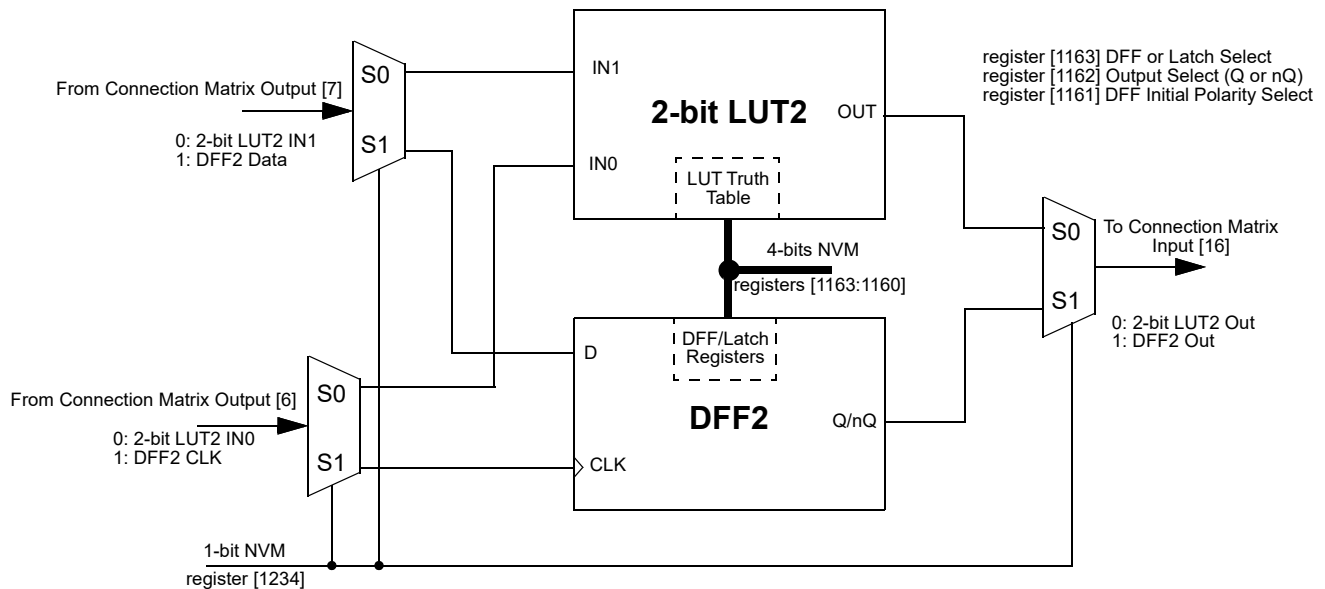

Figure 14: 2-bit LUT2 or DFF2

SLG46827-A

Auto AEC-Q100 Qualified GreenPAK Programmable Mixed-Signal Matrix with In-System Debug

7.1.1 2-Bit LUT or D Flip-Flop Macrocell Used as 2-Bit LUT

Table 25: 2-bit LUT0 Truth Table

IN1	IN0	OUT	
0	0	register [1152]	LSB
0	1	register [1153]	
1	0	register [1154]	
1	1	register [1155]	MSB

Table 26: 2-bit LUT1 Truth Table

IN1	IN0	OUT	
0	0	register [1156]	LSB
0	1	register [1157]	
1	0	register [1158]	
1	1	register [1159]	MSB

Table 27: 2-bit LUT2 Truth Table

IN1	IN0	OUT	
0	0	register [1160]	LSB
0	1	register [1161]	
1	0	register [1162]	
1	1	register [1163]	MSB

This macrocell, when programmed for a LUT function, uses a 4-bit register to define their output function:

2-Bit LUT0 is defined by registers [1155:1152]

2-Bit LUT1 is defined by registers [1159:1156]

2-Bit LUT2 is defined by registers [1163:1160]

Table 28 shows the register bits for the standard digital logic devices (AND, NAND, OR, NOR, XOR, XNOR) that can be created within each of the 2-bit LUT logic cells.

Table 28: 2-bit LUT Standard Digital Functions

Function	MSB			LSB
AND-2	1	0	0	0
NAND-2	0	1	1	1
OR-2	1	1	1	0
NOR-2	0	0	0	1
XOR-2	0	1	1	0
XNOR-2	1	0	0	1

SLG46827-A

Auto AEC-Q100 Qualified GreenPAK
Programmable Mixed-Signal Matrix with In-System Debug

7.1.2 Initial Polarity Operations

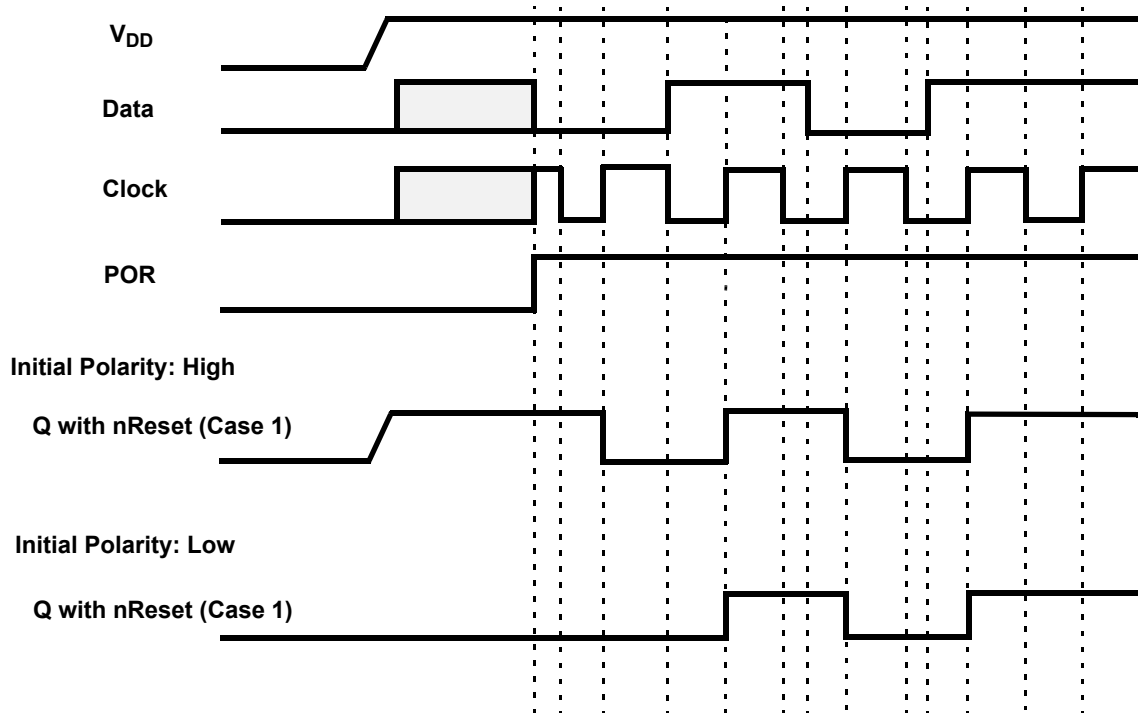

Figure 15: DFF Polarity Operations

7.2 2-BIT LUT OR PROGRAMMABLE PATTERN GENERATOR

The SLG46827-A has one combination function macrocell that can serve as a logic or timing function. This macrocell can serve as a Look Up Table (LUT), or Programmable Pattern Generator (PGen).

When used to implement LUT functions, the 2-bit LUT takes in two input signals from the connection matrix and produces a single output, which goes back into the connection matrix. When used as a LUT to implement combinatorial logic functions, the outputs of the LUT can be configured to any user defined function, including the following standard digital logic devices (AND, NAND, OR, NOR, XOR, XNOR). The user can also define the combinatorial relationship between inputs and outputs to be any selectable function.

When operating as a Programmable Pattern Generator, the output of the macrocell with clock out a sequence of two to sixteen bits that are user selectable in their bit values, and user selectable in the number of bits (up to sixteen) that are output before the pattern repeats.

SLG46827-A

Auto AEC-Q100 Qualified GreenPAK
Programmable Mixed-Signal Matrix with In-System Debug

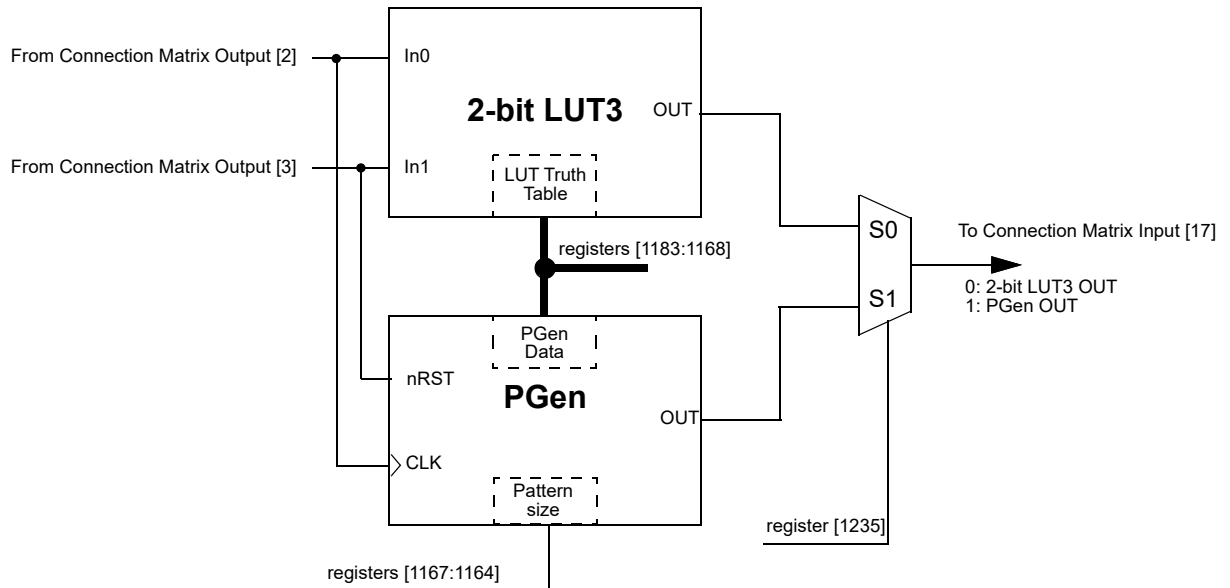

Figure 16: 2-bit LUT3 or PGen

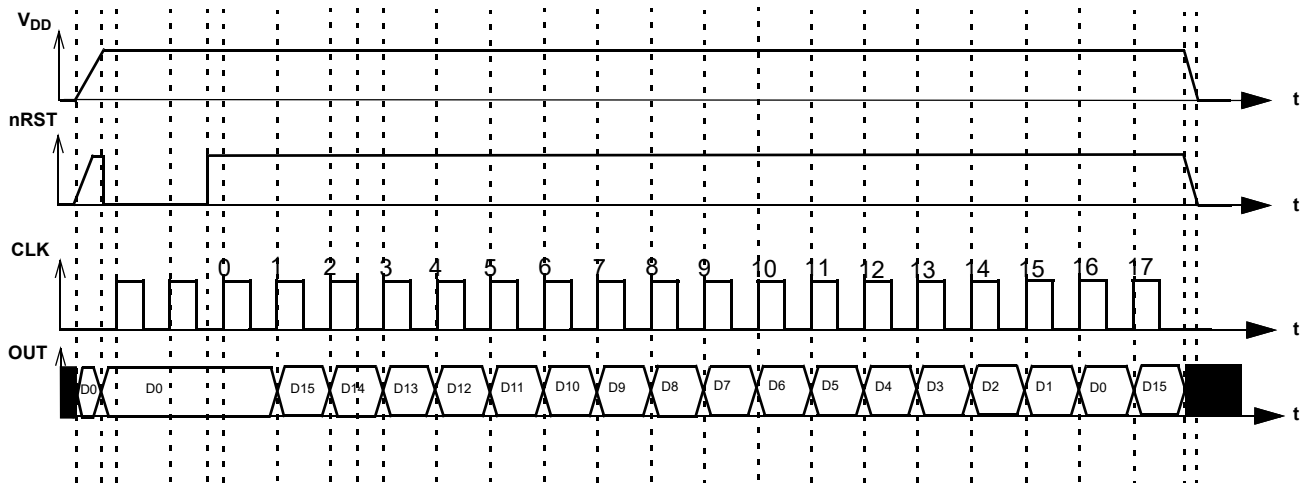

Figure 17: PGen Timing Diagram

SLG46827-A

Auto AEC-Q100 Qualified GreenPAK Programmable Mixed-Signal Matrix with In-System Debug

7.2.1 2-Bit LUT or PGen Macrocell Used as 2-Bit LUT

Table 29: 2-bit LUT1 Truth Table

IN1	IN0	OUT	
0	0	register [1164]	LSB
0	1	register [1165]	
1	0	register [1166]	
1	1	register [1167]	MSB

This macrocell, when programmed for a LUT function, uses a 4-bit register to define their output function:

2-Bit LUT3 is defined by [1167:1164]

Table 30 shows the register bits for the standard digital logic devices (AND, NAND, OR, NOR, XOR, XNOR) that can be created within each of the 2-bit LUT logic cells.

Table 30: 2-bit LUT Standard Digital Functions

Function	MSB			LSB
AND-2	1	0	0	0
NAND-2	0	1	1	1
OR-2	1	1	1	0
NOR-2	0	0	0	1
XOR-2	0	1	1	0
XNOR-2	1	0	0	1

7.3 3-BIT LUT OR D FLIP-FLOP WITH SET/RESET MACROCELLS

There are six macrocells that can serve as either 3-bit LUTs or as D Flip-Flops with Set/Reset inputs. When used to implement LUT functions, the 3-bit LUTs each take in three input signals from the connection matrix and produce a single output, which goes back into the connection matrix. When used to implement D Flip-Flop function, the three input signals from the connection matrix go to the data (D) and clock (CLK), and Reset/Set (nRST/nSET) inputs for the Flip-Flop, with the output going back to the connection matrix.

DFF3 operation is described below:

- If register [1237] = 0, and the CLK is rising edge triggered, then Q = D, otherwise Q will not change
- If register [1237] = 1, then data from D is written into the DFF by the rising edge on CLK and output to Q by the falling edge on CLK.

SLG46827-A

Auto AEC-Q100 Qualified GreenPAK
Programmable Mixed-Signal Matrix with In-System Debug

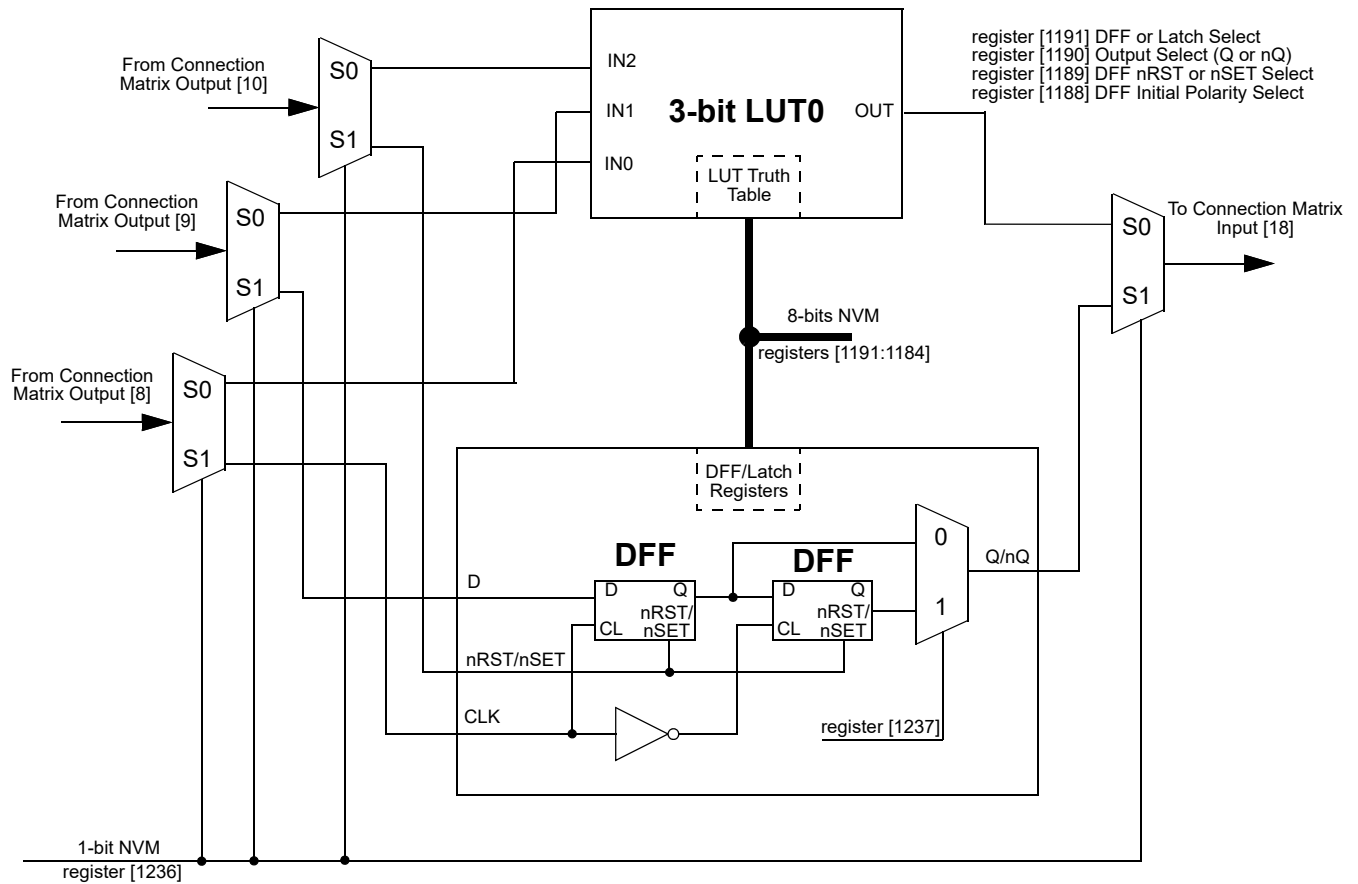

Figure 18: 3-bit LUT0 or DFF3

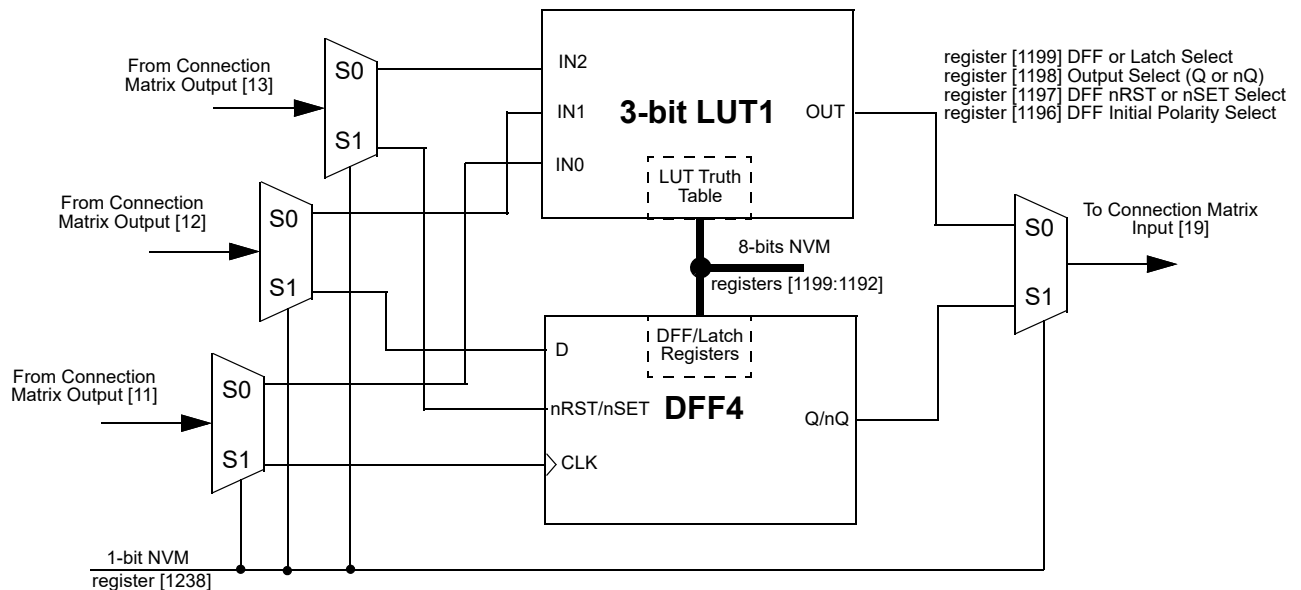

Figure 19: 3-bit LUT1 or DFF4

SLG46827-A

Auto AEC-Q100 Qualified GreenPAK
Programmable Mixed-Signal Matrix with In-System Debug

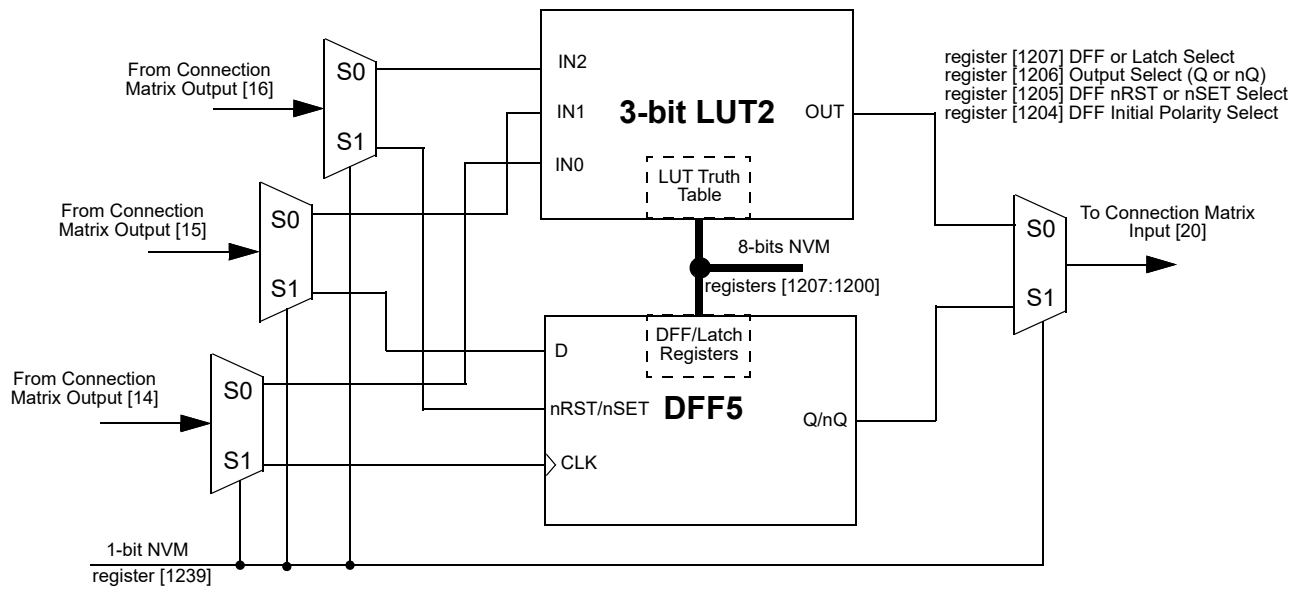

Figure 20: 3-bit LUT2 or DFF5

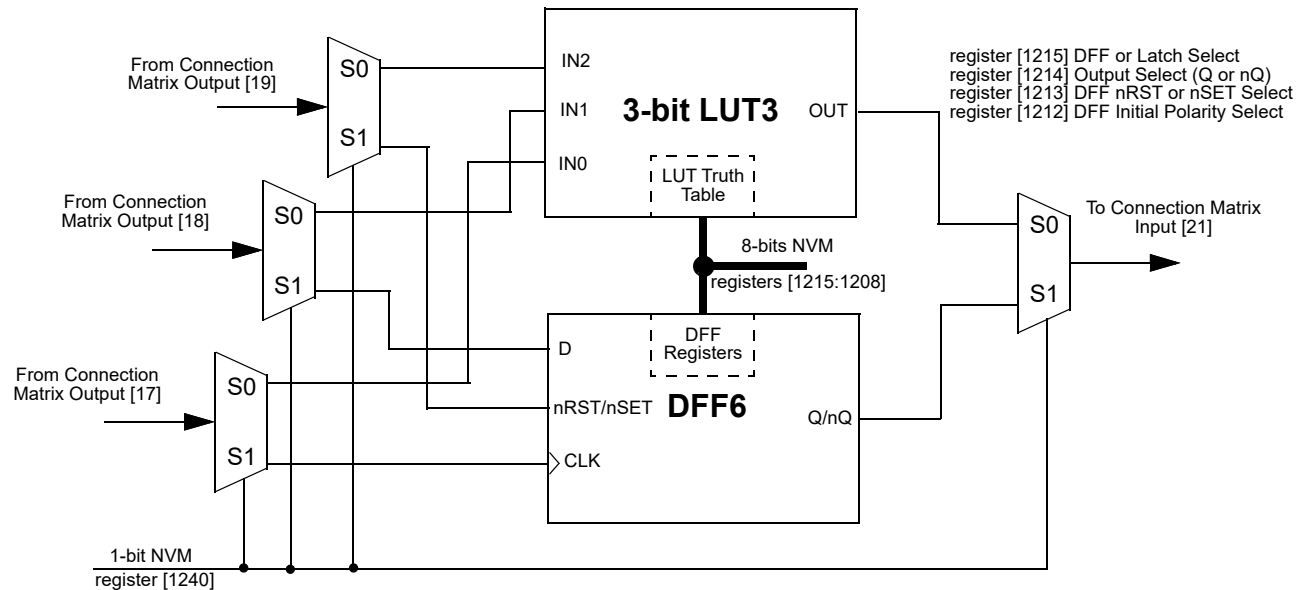

Figure 21: 3-bit LUT3 or DFF6

SLG46827-A

Auto AEC-Q100 Qualified GreenPAK
Programmable Mixed-Signal Matrix with In-System Debug

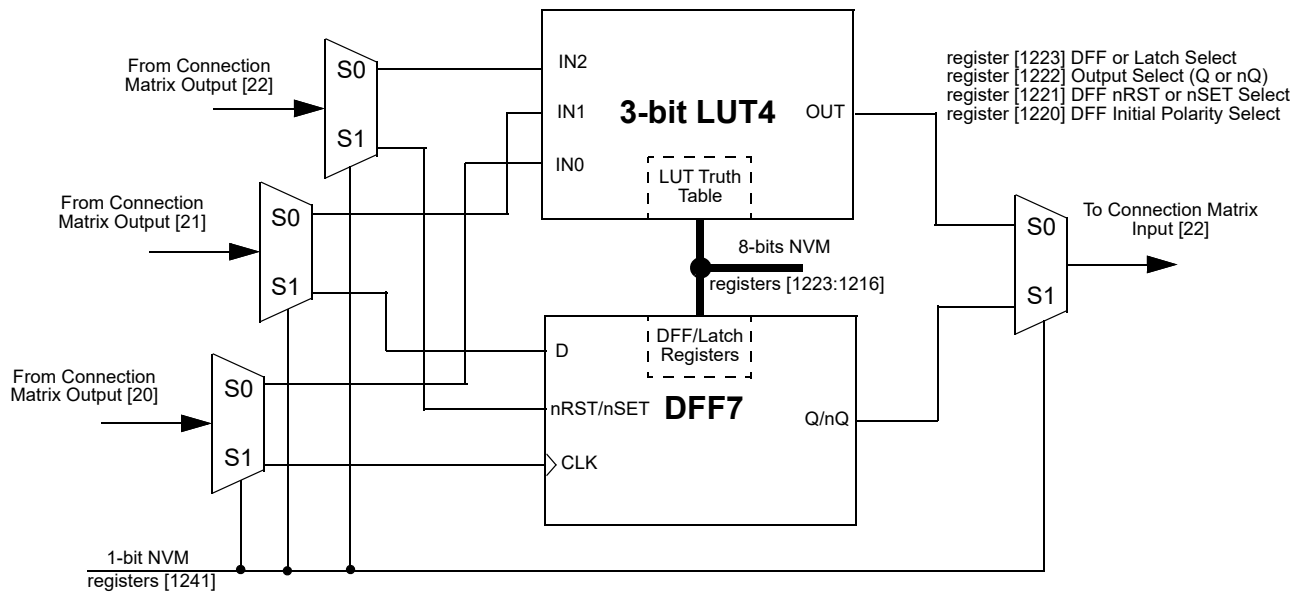

Figure 22: 3-bit LUT4 or DFF7

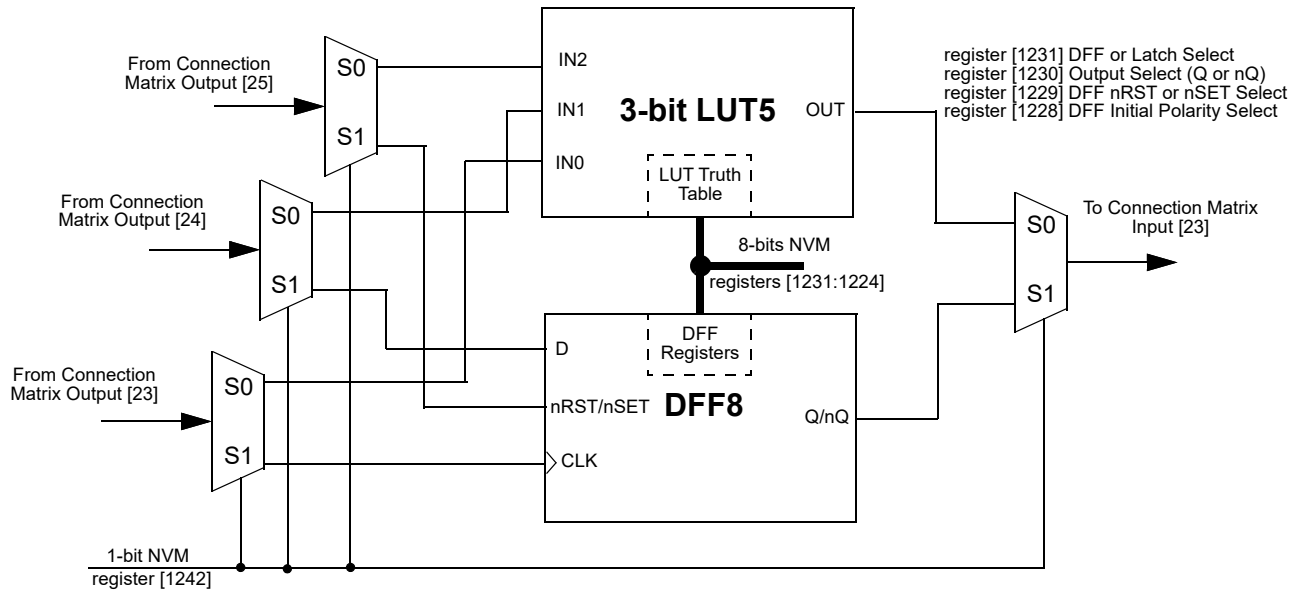

Figure 23: 3-bit LUT5 or DFF8

SLG46827-A

Auto AEC-Q100 Qualified GreenPAK Programmable Mixed-Signal Matrix with In-System Debug

7.3.1 3-Bit LUT or D Flip-Flop Macrocells Used as 3-Bit LUTs

Table 31: 3-bit LUT0 Truth Table

IN2	IN1	IN0	OUT	
0	0	0	register [1184]	LSB
0	0	1	register [1185]	
0	1	0	register [1186]	
0	1	1	register [1187]	
1	0	0	register [1188]	
1	0	1	register [1189]	
1	1	0	register [1190]	
1	1	1	register [1191]	MSB

Table 32: 3-bit LUT1 Truth Table

IN2	IN1	IN0	OUT	
0	0	0	register [1192]	LSB
0	0	1	register [1193]	
0	1	0	register [1194]	
0	1	1	register [1195]	
1	0	0	register [1196]	
1	0	1	register [1197]	
1	1	0	register [1198]	
1	1	1	register [1199]	MSB

Table 33: 3-bit LUT2 Truth Table

IN2	IN1	IN0	OUT	
0	0	0	register [1200]	LSB
0	0	1	register [1201]	
0	1	0	register [1202]	
0	1	1	register [1203]	
1	0	0	register [1204]	
1	0	1	register [1205]	
1	1	0	register [1206]	
1	1	1	register [1207]	MSB

Table 34: 3-bit LUT3 Truth Table

IN2	IN1	IN0	OUT	
0	0	0	register [1208]	LSB
0	0	1	register [1209]	
0	1	0	register [1210]	
0	1	1	register [1211]	
1	0	0	register [1212]	
1	0	1	register [1213]	
1	1	0	register [1214]	
1	1	1	register [1215]	MSB

Table 35: 3-bit LUT4 Truth Table

IN2	IN1	IN0	OUT	
0	0	0	register [1216]	LSB
0	0	1	register [1217]	
0	1	0	register [1218]	
0	1	1	register [1219]	
1	0	0	register [1220]	
1	0	1	register [1221]	
1	1	0	register [1222]	
1	1	1	register [1223]	MSB

Table 36: 3-bit LUT5 Truth Table

IN2	IN1	IN0	OUT	
0	0	0	register [1224]	LSB
0	0	1	register [1225]	
0	1	0	register [1226]	
0	1	1	register [1227]	
1	0	0	register [1228]	
1	0	1	register [1229]	
1	1	0	register [1230]	
1	1	1	register [1231]	MSB

Each macrocell, when programmed for a LUT function, uses a 8-bit register to define their output function:

3-Bit LUT0 is defined by registers [1191:1184]

3-Bit LUT1 is defined by registers [1199:1192]

3-Bit LUT2 is defined by registers [1207:1200]

3-Bit LUT3 is defined by registers [1215:1208]

3-Bit LUT4 is defined by registers [1223:1216]

3-Bit LUT5 is defined by registers [1231:1224]

SLG46827-A

Auto AEC-Q100 Qualified GreenPAK Programmable Mixed-Signal Matrix with In-System Debug

Table 37 shows the register bits for the standard digital logic devices (AND, NAND, OR, NOR, XOR, XNOR) that can be created within each of the four 3-bit LUT logic cells.

Table 37: 3-bit LUT Standard Digital Functions

Function	MSB							LSB
AND-3	1	0	0	0	0	0	0	0
NAND-3	0	1	1	1	1	1	1	1
OR-3	1	1	1	1	1	1	1	0
NOR-3	0	0	0	0	0	0	0	1
XOR-3	1	0	0	1	0	1	1	0
XNOR-3	0	1	1	0	1	0	0	1

SLG46827-A

Auto AEC-Q100 Qualified GreenPAK
Programmable Mixed-Signal Matrix with In-System Debug

7.3.2 Initial Polarity Operations

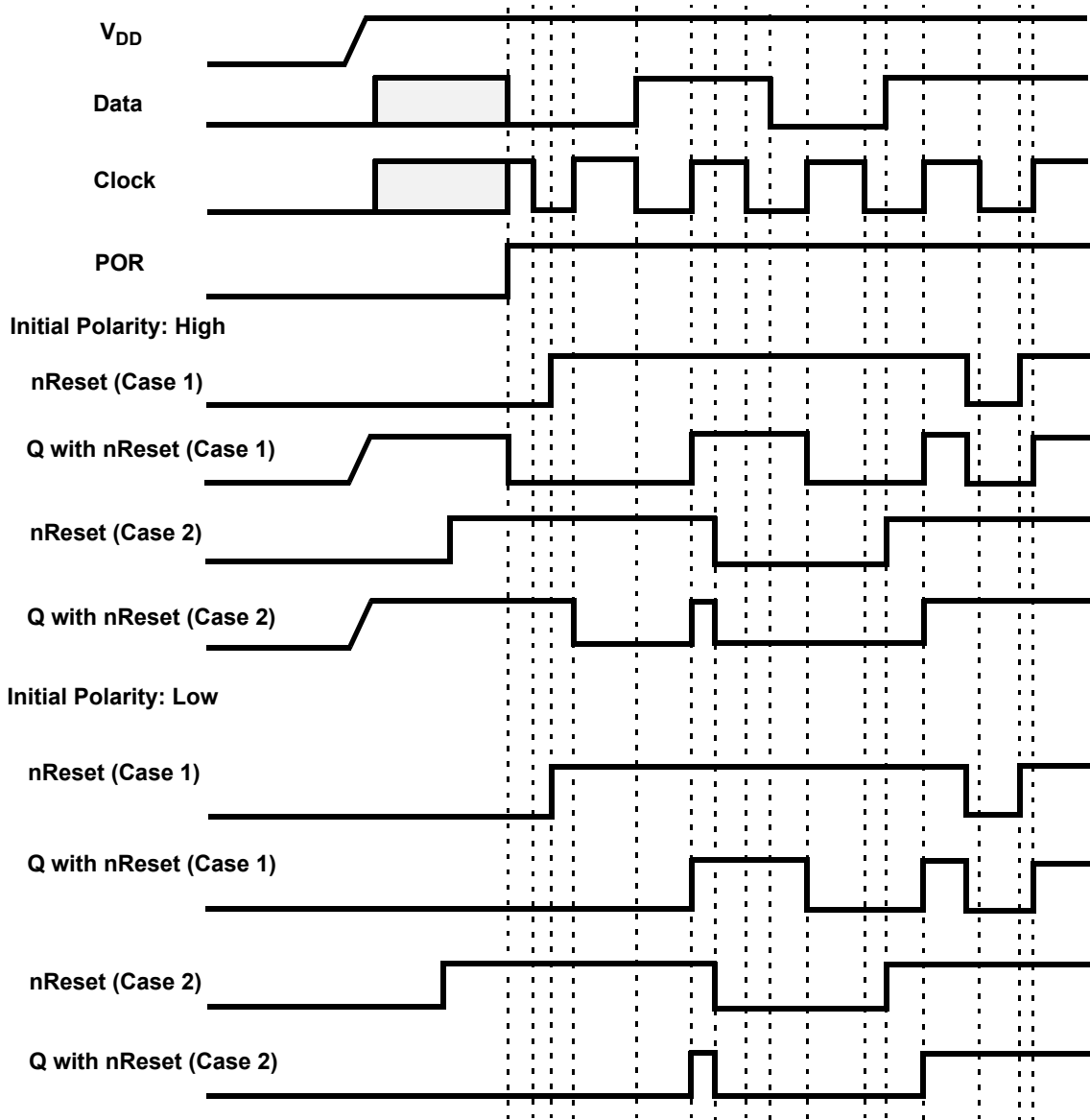

Figure 24: DFF Polarity Operations with nReset

SLG46827-A

Auto AEC-Q100 Qualified GreenPAK
Programmable Mixed-Signal Matrix with In-System Debug

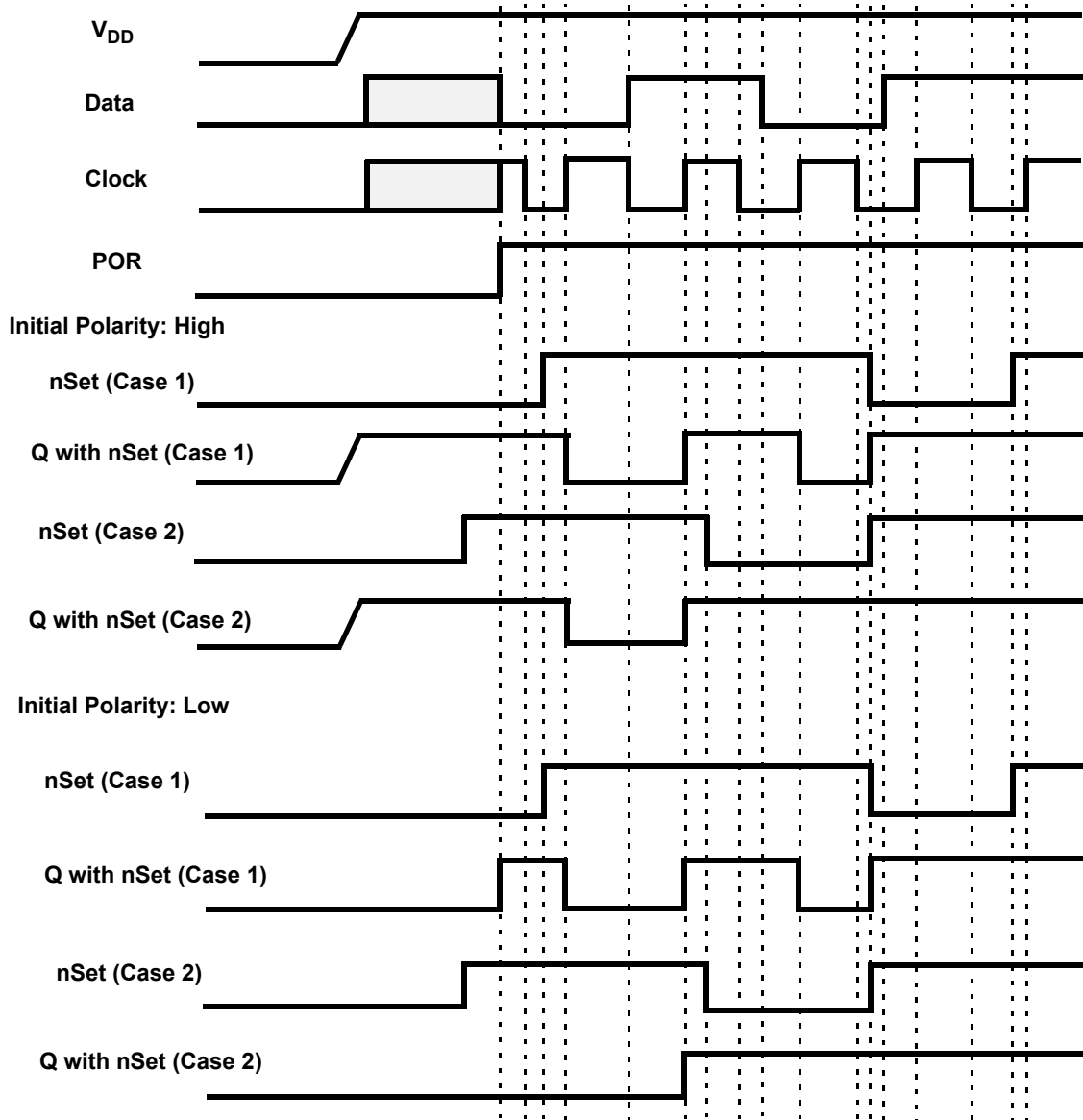

Figure 25: DFF Polarity Operations with nSet

7.4 3-BIT LUT OR PIPE DELAY/RIPPLE COUNTER MACROCELL

There is one macrocell that can serve as either a 3-bit LUT or as a Pipe Delay/Ripple Counter.

When used to implement LUT functions, the 3-bit LUT takes in three input signals from the connection matrix and produces a single output, which goes back into the connection matrix.

When used as a Pipe Delay, there are three inputs signals from the matrix, Input (IN), Clock (CLK), and Reset (nRST). The Pipe Delay cell is built from 16 D Flip-Flop logic cells that provide the three delay options, two of which are user selectable. The DFF cells are tied in series where the output (Q) of each delay cell goes to the next DFF cell input (IN). Both of the two outputs (OUT0 and OUT1) provide user selectable options for 1 to 16 stages of delay. There are delay output points for each set of the OUT0 and OUT1 outputs to a 4-input mux that is controlled by registers [1251:1248] for OUT0 and registers [1255:1252] for OUT1. The 4-input mux is used to control the selection of the amount of delay.

SLG46827-A

Auto AEC-Q100 Qualified GreenPAK Programmable Mixed-Signal Matrix with In-System Debug

The overall time of the delay is based on the clock used in the SLG46827-A design. Each DFF cell has a time delay of the inverse of the clock time (either external clock or the internal Oscillator within the SLG46827-A). The sum of the number of DFF cells used will be the total time delay of the Pipe Delay logic cell. OUT1 Output can be inverted (as selected by register [1256]).

In the Ripple Counter mode, there are 3 options for setting, which use 7 bits. There are 3 bits to set **nSET value (SV)** in range from 0 to 7. It is a value, which will be set into the Ripple Counter outputs when nSET input goes LOW. **End value (EV)** will use 3 bits for setting outputs code, which will be last code in the cycle. After reaching the EV, the Ripple Counter goes to the first code by the rising edge on CLK input. The **Functionality mode** option uses 1 bit. This setting defines how exactly Ripple Counter will operate.

The user can select one of the functionality modes by register: RANGE or FULL. If the RANGE option is selected, the count starts from SV. If UP input is LOW the count goes down: $SV \rightarrow EV \rightarrow EV-1$ to $SV+1 \rightarrow SV$, and others (if SV is smaller than EV), or $SV \rightarrow SV-1$ to $EV+1 \rightarrow EV \rightarrow SV$ (if SV is bigger than EV). If UP input is HIGH, count starts from SV up to EV, and others.

In the FULL range configuration the Ripple Counter functions as follows. If UP input is LOW, the count starts from SV and goes down to 0. Then current counter value jumps to EV and goes down to 0, and others.

If UP input is HIGH, count goes up starting from SV. Then current counter value jumps to 0 and counts up to EV, and others. See Ripple Counter functionality example in [Figure 27](#).

Every step is executed by the rising edge on CLK input.

SLG46827-A

Auto AEC-Q100 Qualified GreenPAK
 Programmable Mixed-Signal Matrix with In-System Debug

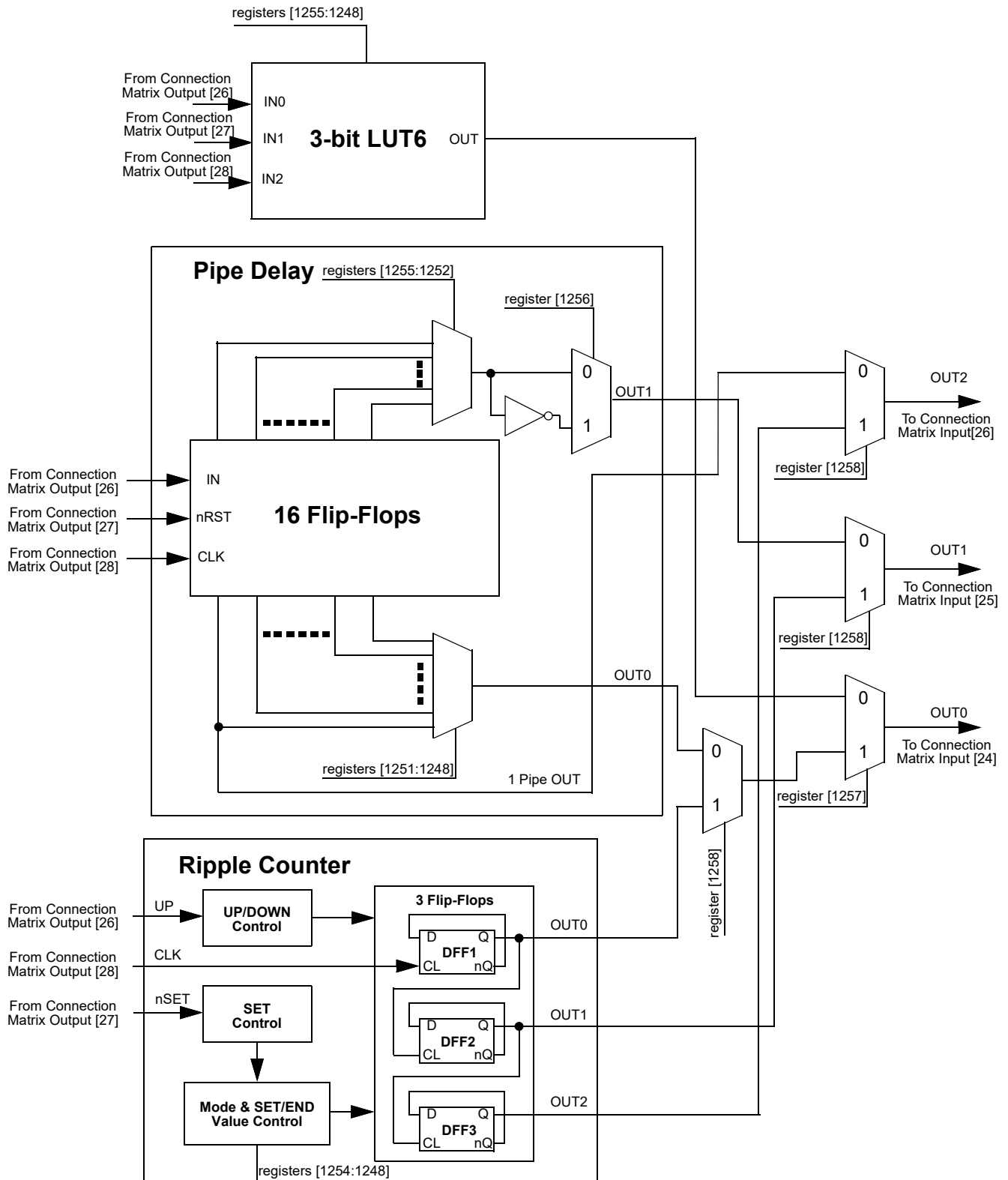

Figure 26: 3-bit LUT6/Pipe Delay/Ripple Counter

SLG46827-A

Auto AEC-Q100 Qualified GreenPAK
Programmable Mixed-Signal Matrix with In-System Debug

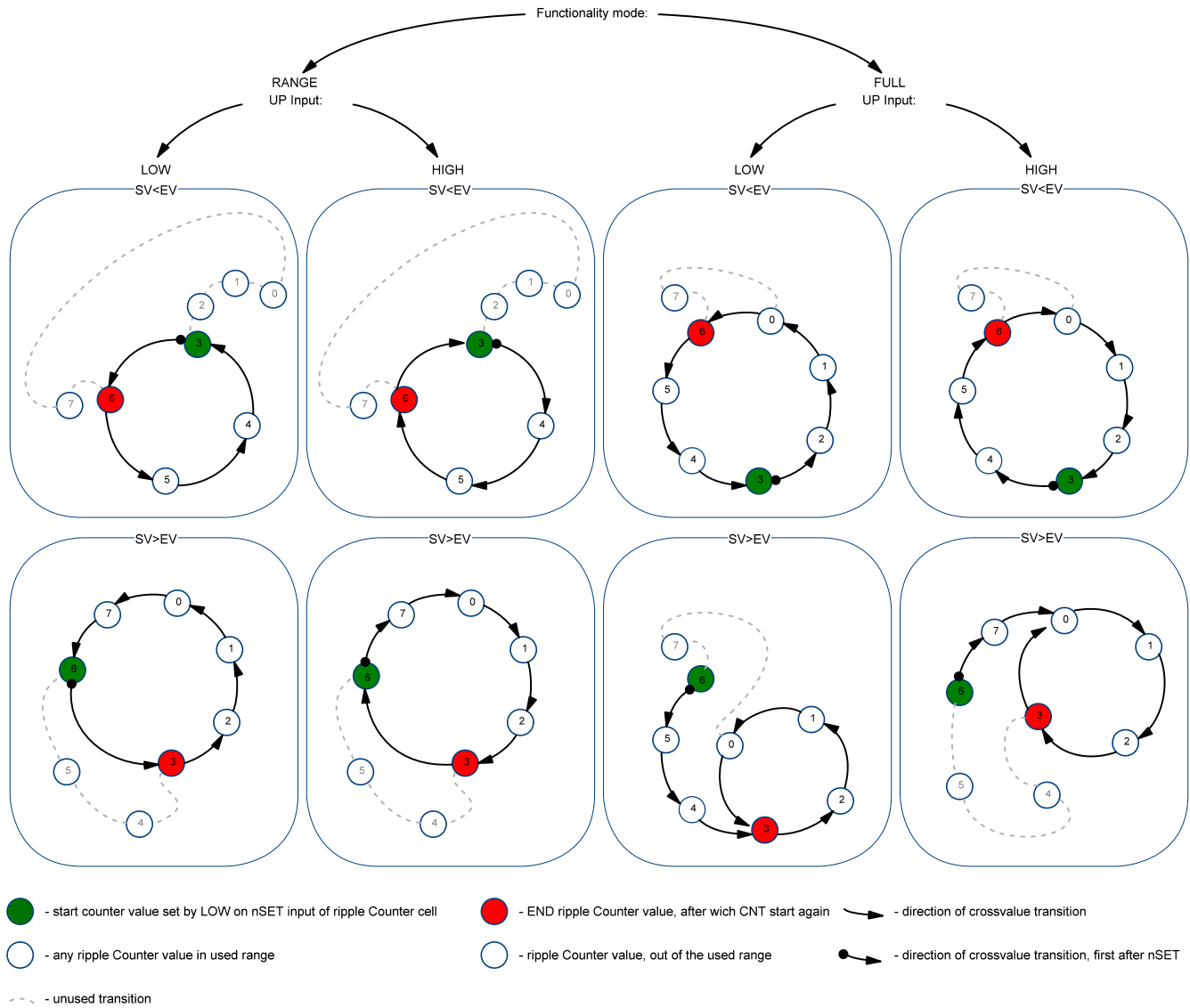

Figure 27: Example: Ripple Counter Functionality

7.4.1 3-Bit LUT or Pipe Delay Macrocells Used as 3-Bit LUT

Table 38: 3-bit LUT6 Truth Table

IN2	IN1	IN0	OUT
0	0	0	register [1248]
0	0	1	register [1249]
0	1	0	register [1250]
0	1	1	register [1251]
1	0	0	register [1252]
1	0	1	register [1253]
1	1	0	register [1254]
1	1	1	register [1255]

SLG46827-A

Auto AEC-Q100 Qualified GreenPAK Programmable Mixed-Signal Matrix with In-System Debug

Each macrocell, when programmed for a LUT function, uses a 8-bit register to define their output function:

3-Bit LUT6 is defined by registers [1255:1248]

SLG46827-A

Auto AEC-Q100 Qualified GreenPAK Programmable Mixed-Signal Matrix with In-System Debug

8 Multi-Function Macrocells

The SLG46827-A has 8 Multi-Function macrocells that can serve more than one logic or timing function. In each case, they can serve as a LUT, DFF with flexible settings, or as CNT/DLY with multiple modes such as One Shot, Frequency Detect, Edge Detect, and others. Also, the macrocell is capable to combine those functions: LUT/DFF connected to CNT/DLY or CNT/DLY connected to LUT/DFF, see [Figure 28](#).

See the list below for the functions that can be implemented in these macrocells:

- Seven macrocells that can serve as 3-bit LUTs/D Flip-Flops and as 8-Bit Counter/Delays
- One macrocell that can serve as a 4-bit LUT/D Flip-Flop and as 16-Bit Counter/Delay/FSM

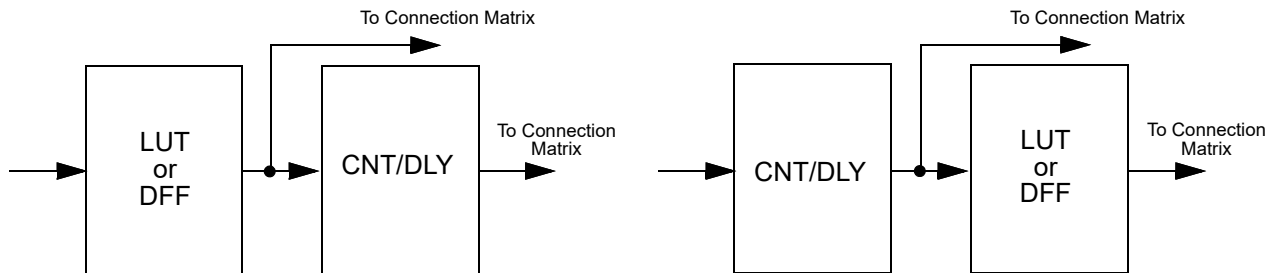

Figure 28: Possible Connections Inside Multi-Function Macrocell

Inputs/Outputs for the 8 Multi-Function macrocells are configured from the connection matrix with specific logic functions being defined by the state of NVM bits.

When used as a LUT to implement combinatorial logic functions, the outputs of the LUTs can be configured to any user defined function, including the following standard digital logic devices (AND, NAND, OR, NOR, XOR, XNOR).

8.1 3-BIT LUT OR DFF/LATCH WITH 8-BIT COUNTER/DELAY MACROCELLS

There are seven macrocells that can serve as 3-bit LUTs/D Flip-Flops and as 8-Bit Counter/Delays.

When used to implement LUT functions, the 3-bit LUTs each take in three input signals from the connection matrix and produce a single output, which goes back into the connection matrix or can be connected to CNT/DLY's input.

When used to implement D Flip-Flop function, the three input signals from the connection matrix go to the data (D), clock (CLK), and Reset/Set (nRST/nSET) inputs of the Flip-Flop, with the output going back to the connection matrix or to the CNT/DLY's input.

When used to implement Counter/Delays, each macrocell has a dedicated matrix input connection. For flexibility, each of these macrocells has a large selection of internal and external clock sources, as well as the option to chain from the output of the previous (N-1) CNT/DLY macrocell, to implement longer count/delay circuits. These macrocells can also operate in a One-Shot mode, which will generate an output pulse of user-defined width. They can also operate in a Frequency Detection or Edge Detection mode.

Counter/Delay macrocell has an initial value, which define its initial value after GPAK is powered up. It is possible to select initial Low or initial High, as well as initial value defined by a Delay In signal.

For example, in case initial LOW option is used, the rising edge delay will start operation.

For timing diagrams refer to [Section 8.2](#).

Note: After two DFF – counters initialize with counter data = 0 after POR.
 Initial state = 1 – counters initialize with counter data = 0 after POR.
 Initial state = 0 And After two DFF is bypass – counters initialize with counter data after POR.

SLG46827-A

Auto AEC-Q100 Qualified GreenPAK
Programmable Mixed-Signal Matrix with In-System Debug

Three of eight macrocells can have their current count value read via I²C (CNT0, CNT2, and CNT4). However, it is possible to change the counter data (value counter starts operating from) for any macrocell using I²C write commands. In this mode, it is possible to load count data immediately (after two DFF) or after counter ends counting. See Section 15.7.1 for further details.

8.1.1 3-Bit LUT or 8-Bit CNT/DLY Block Diagrams

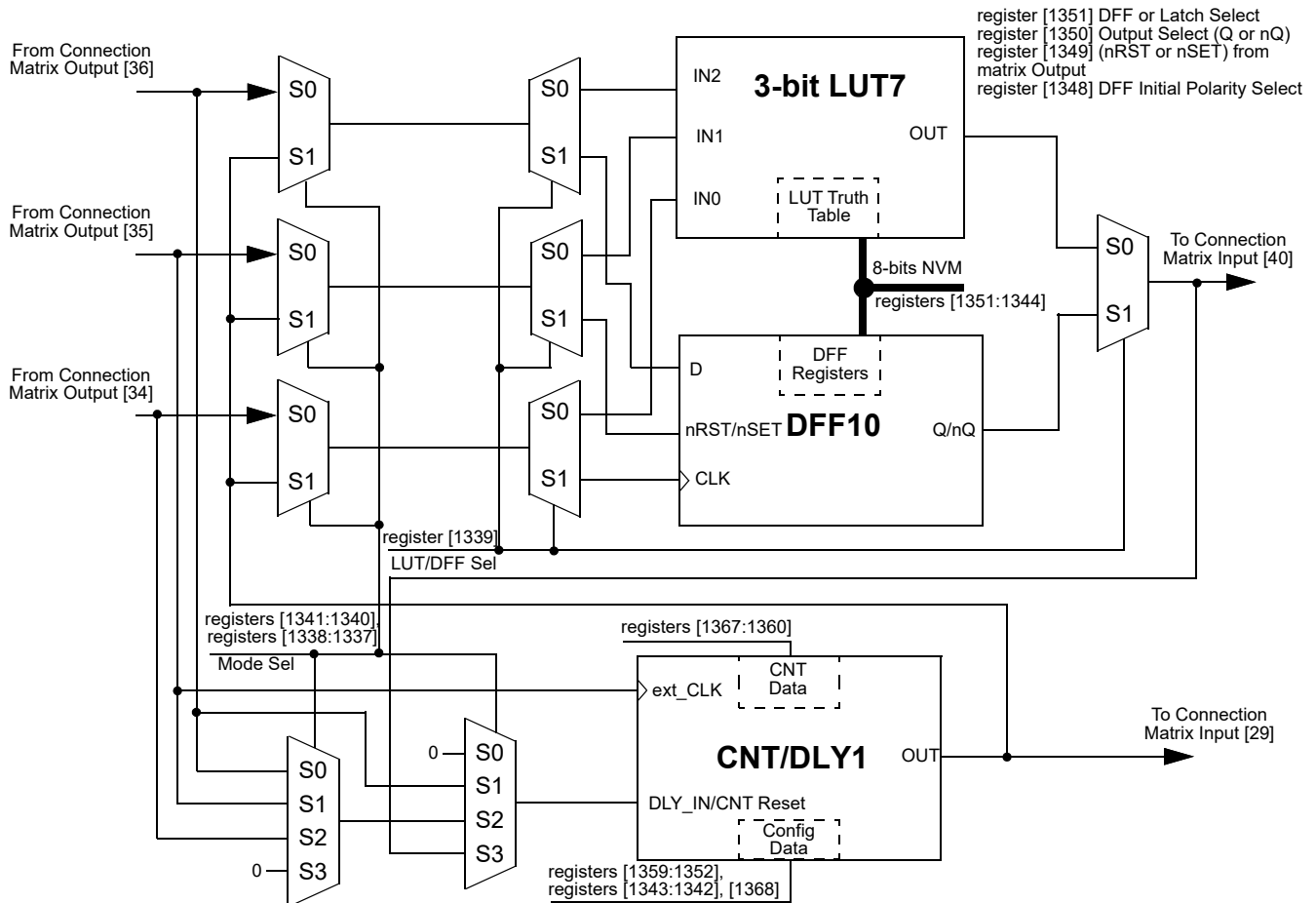

Figure 29: 8-bit Multi-Function Macrocells Block Diagram (3-bit LUT7/DFF10, CNT/DLY1)

SLG46827-A

Auto AEC-Q100 Qualified GreenPAK
Programmable Mixed-Signal Matrix with In-System Debug

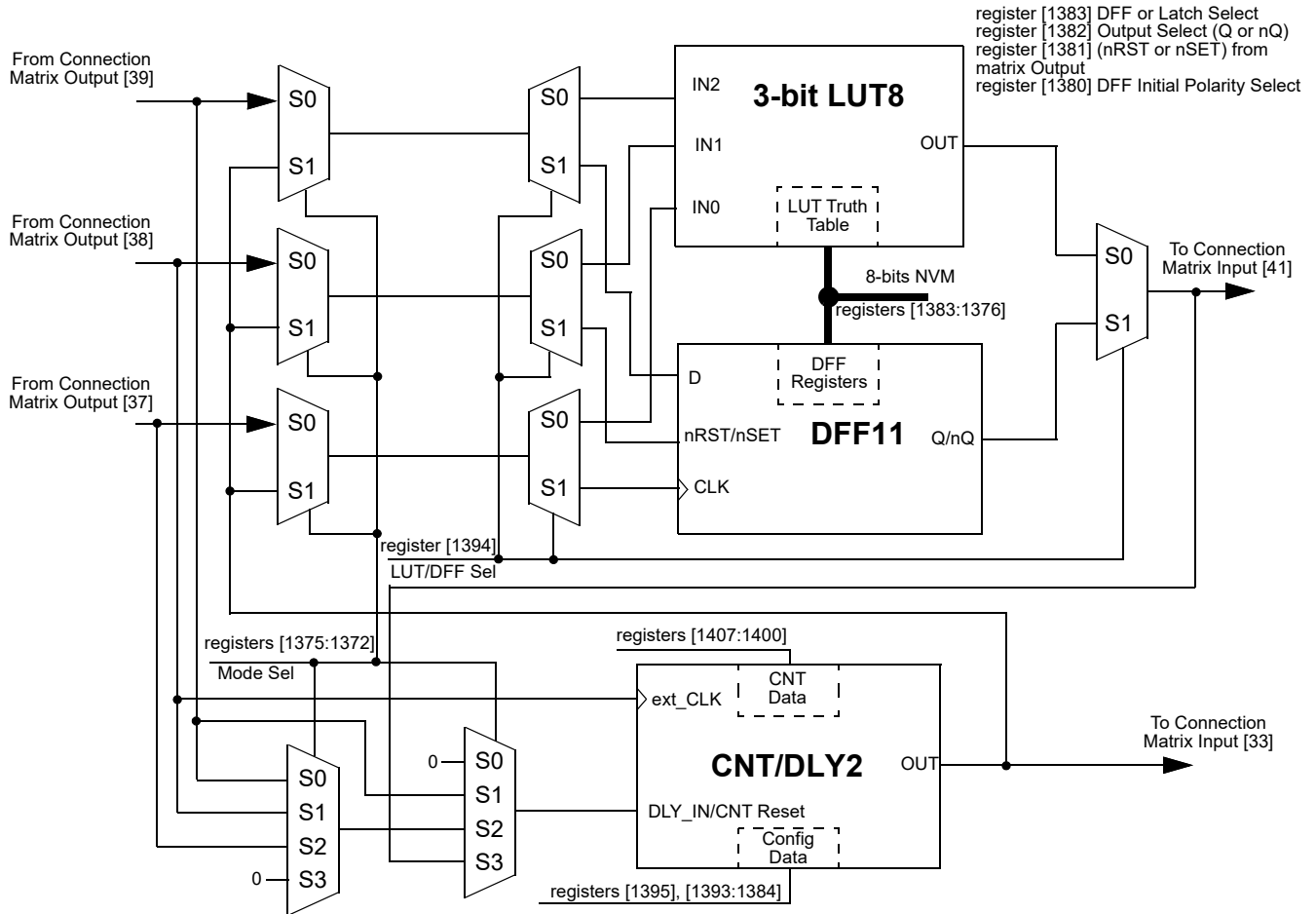

Figure 30: 8-bit Multi-Function Macrocells Block Diagram (3-bit LUT8/DFF11, CNT/DLY2)

SLG46827-A

Auto AEC-Q100 Qualified GreenPAK
Programmable Mixed-Signal Matrix with In-System Debug

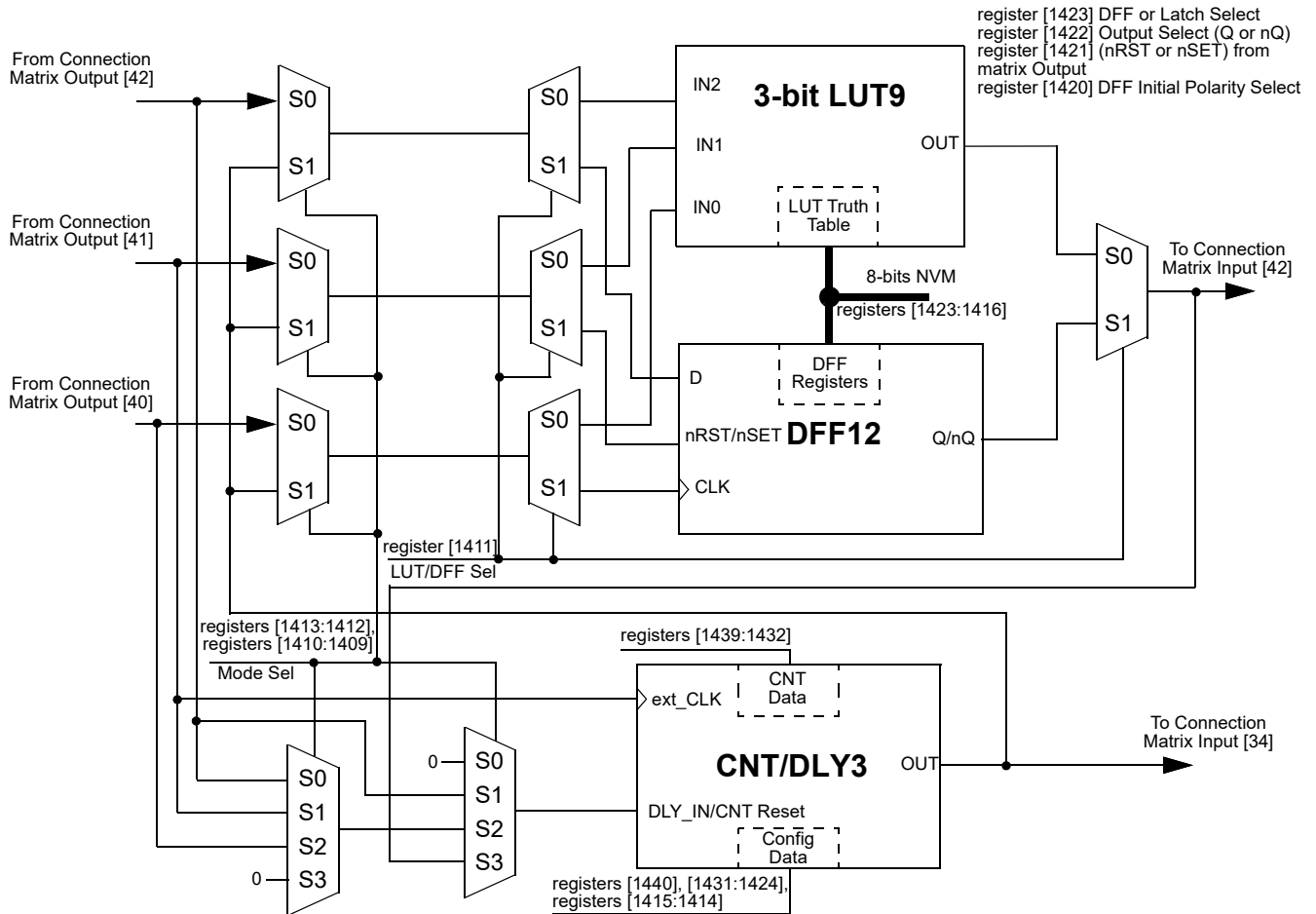

Figure 31: 8-bit Multi-Function Macrocells Block Diagram (3-bit LUT9/DFF12, CNT/DLY3)

SLG46827-A

Auto AEC-Q100 Qualified GreenPAK
Programmable Mixed-Signal Matrix with In-System Debug

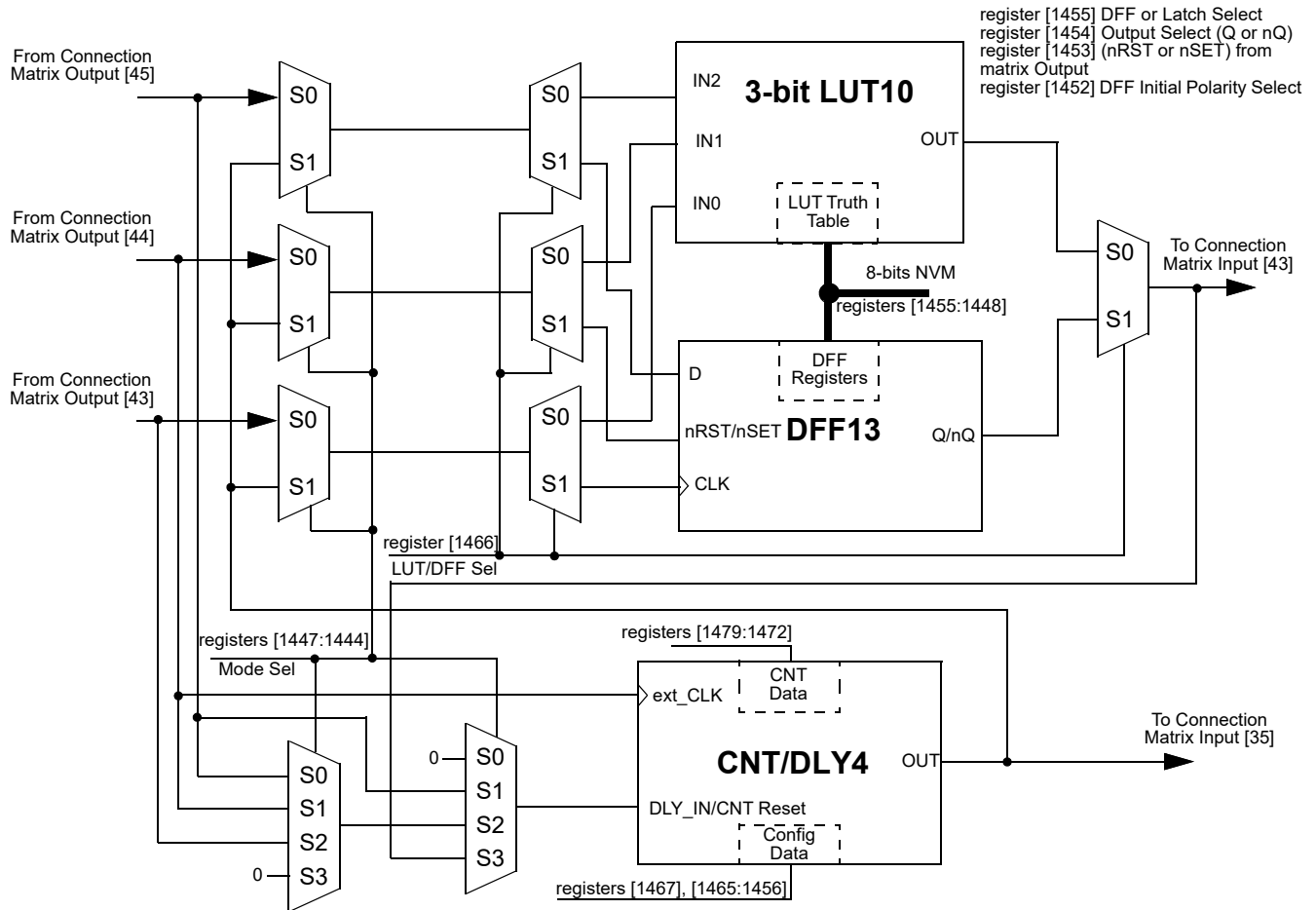

Figure 32: 8-bit Multi-Function Macrocells Block Diagram (3-bit LUT10/DFF13, CNT/DLY4)

SLG46827-A

Auto AEC-Q100 Qualified GreenPAK
Programmable Mixed-Signal Matrix with In-System Debug

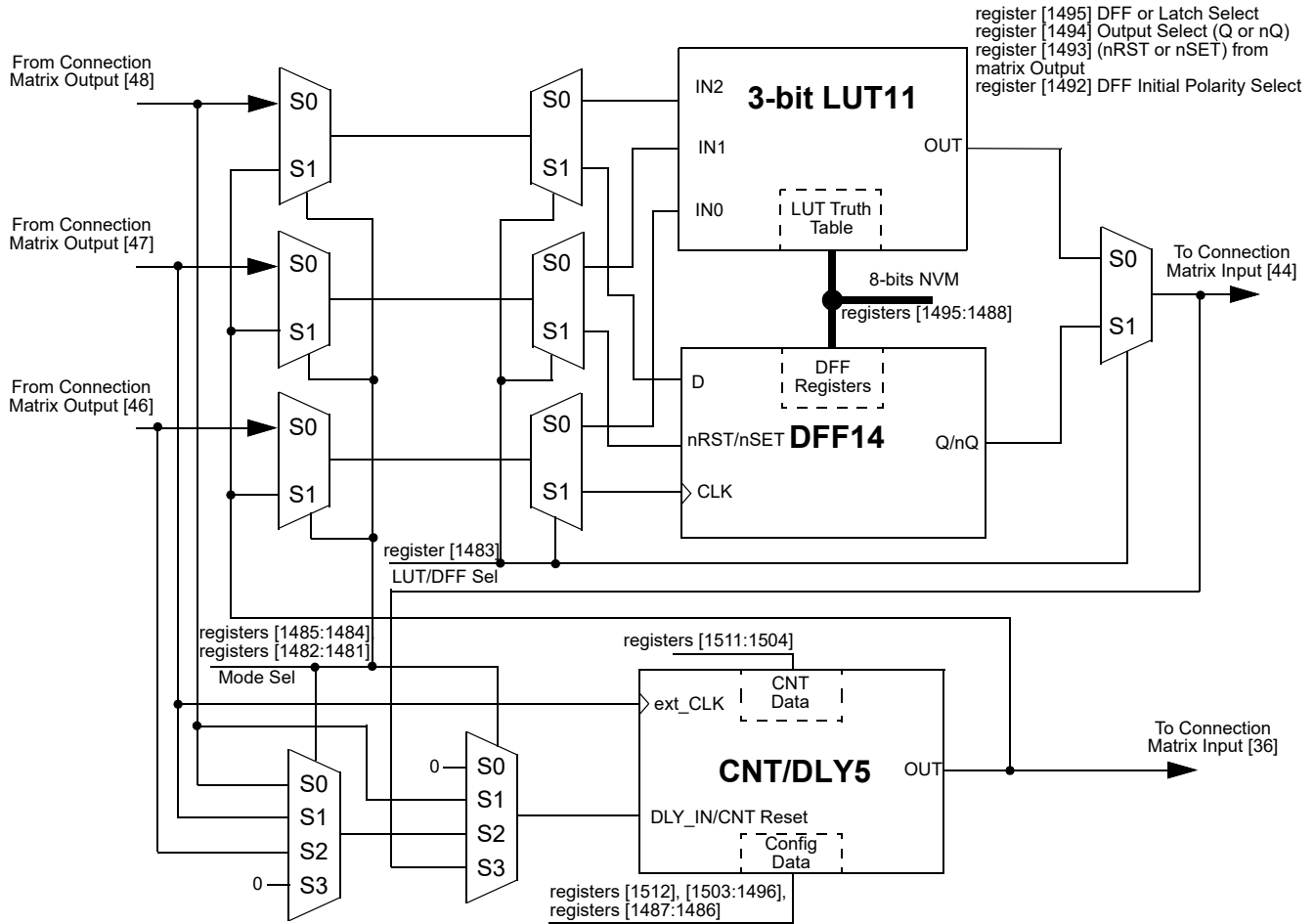

Figure 33: 8-bit Multi-Function Macrocells Block Diagram (3-bit LUT11/DFF14, CNT/DLY5)

SLG46827-A

Auto AEC-Q100 Qualified GreenPAK
Programmable Mixed-Signal Matrix with In-System Debug

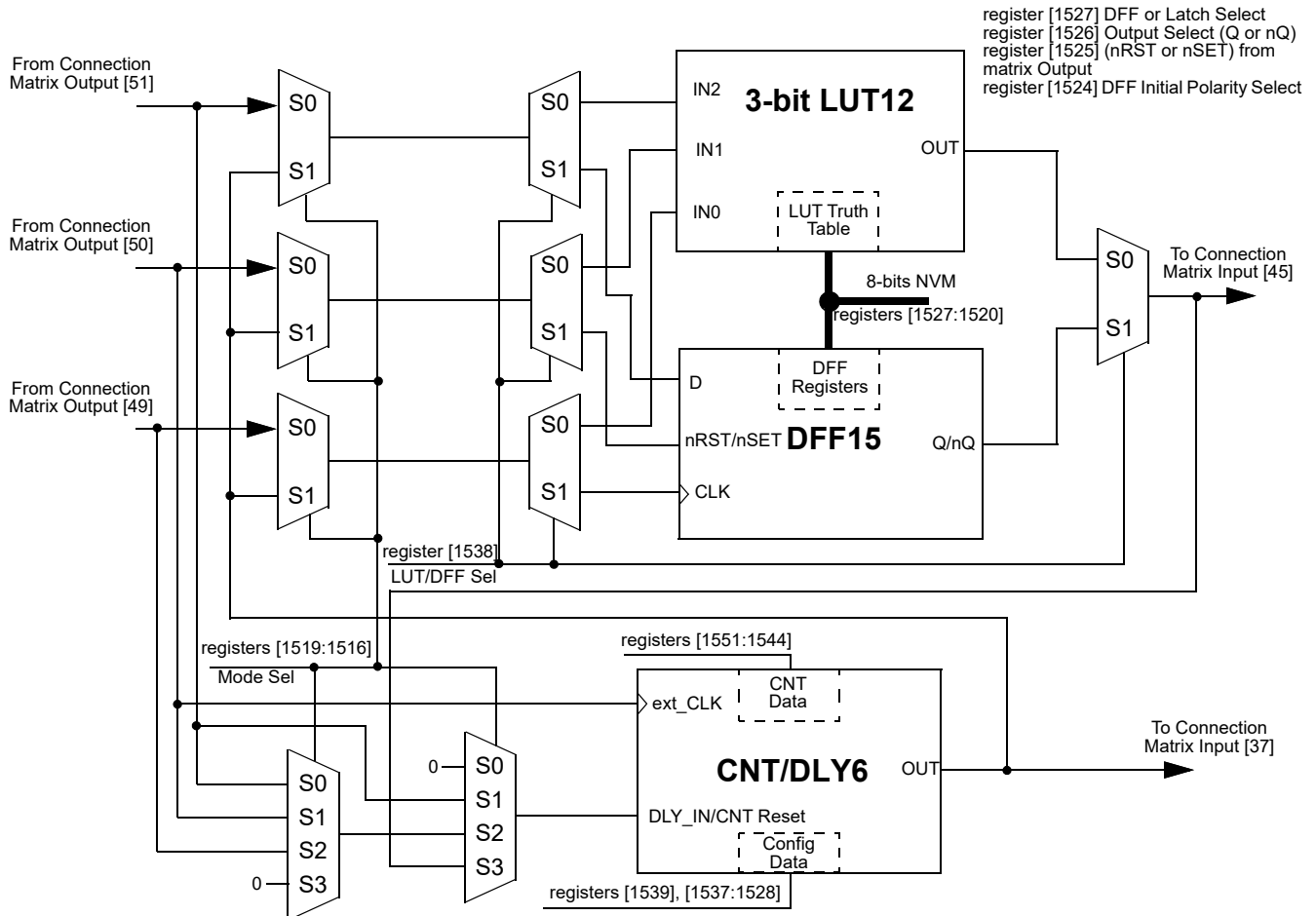

Figure 34: 8-bit Multi-Function Macrocells Block Diagram (3-bit LUT12/DFF15, CNT/DLY6)

SLG46827-A

Auto AEC-Q100 Qualified GreenPAK
Programmable Mixed-Signal Matrix with In-System Debug

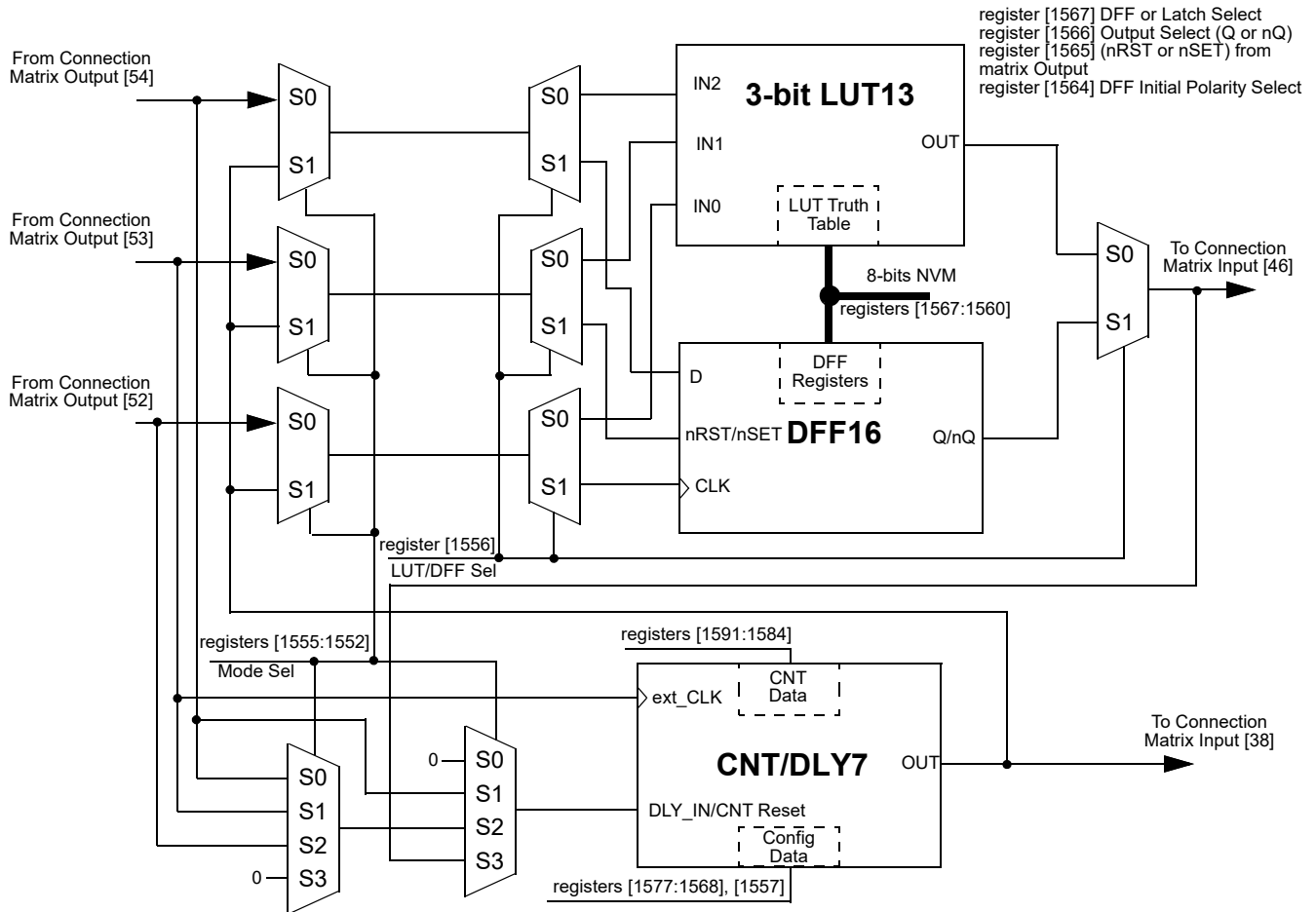

Figure 35: 8-bit Multi-Function Macrocells Block Diagram (3-bit LUT13/DFF16, CNT/DLY7)

As shown in Figures 24 to 30 there is a possibility to use LUT/DFF and CNT/DLY simultaneously.

Note: It is not possible to use LUT and DFF at once, one of these macrocells must be selected.

- Case 1. LUT/DFF in front of CNT/DLY. Three input signals from the connection matrix go to previously selected LUT or DFF's inputs and produce a single output which goes to a CNT/DLY input. In its turn Counter/Delay's output goes back to the matrix.
- Case 2. CNT/DLY in front of LUT/DFF. Two input signals from the connection matrix go to CNT/DLY's inputs (IN and CLK). Its output signal can be connected to any input of previously selected LUT or DFF, after which the signal goes back to the matrix.
- Case 3. Single LUT/DFF or CNT/DLY. Also, it is possible to use a standalone LUT/DFF or CNT/DLY. In this case, all inputs and output of the macrocell are connected to the matrix.

SLG46827-A

Auto AEC-Q100 Qualified GreenPAK Programmable Mixed-Signal Matrix with In-System Debug

8.1.2 3-Bit LUT or CNT/DLYs Used as 3-Bit LUTs

Table 39: 3-bit LUT7 Truth Table

IN2	IN1	IN0	OUT	
0	0	0	register [1344]	LSB
0	0	1	register [1345]	
0	1	0	register [1346]	
0	1	1	register [1347]	
1	0	0	register [1348]	
1	0	1	register [1349]	
1	1	0	register [1350]	
1	1	1	register [1351]	MSB

Table 40: 3-bit LUT8 Truth Table

IN2	IN1	IN0	OUT	
0	0	0	register [1376]	LSB
0	0	1	register [1377]	
0	1	0	register [1378]	
0	1	1	register [1379]	
1	0	0	register [1380]	
1	0	1	register [1381]	
1	1	0	register [1382]	
1	1	1	register [1383]	MSB

Table 41: 3-bit LUT9 Truth Table

IN2	IN1	IN0	OUT	
0	0	0	register [1416]	LSB
0	0	1	register [1417]	
0	1	0	register [1418]	
0	1	1	register [1419]	
1	0	0	register [1420]	
1	0	1	register [1421]	
1	1	0	register [1422]	
1	1	1	register [1423]	MSB

Table 42: 3-bit LUT10 Truth Table

IN2	IN1	IN0	OUT	
0	0	0	register [1448]	LSB
0	0	1	register [1449]	
0	1	0	register [1450]	
0	1	1	register [1451]	
1	0	0	register [1452]	
1	0	1	register [1453]	
1	1	0	register [1454]	
1	1	1	register [1455]	MSB

Table 43: 3-bit LUT11 Truth Table

IN2	IN1	IN0	OUT	
0	0	0	register [1488]	LSB
0	0	1	register [1489]	
0	1	0	register [1490]	
0	1	1	register [1491]	
1	0	0	register [1492]	
1	0	1	register [1493]	
1	1	0	register [1494]	
1	1	1	register [1495]	MSB

Table 44: 3-bit LUT12 Truth Table

IN2	IN1	IN0	OUT	
0	0	0	register [1520]	LSB
0	0	1	register [1521]	
0	1	0	register [1522]	
0	1	1	register [1523]	
1	0	0	register [1524]	
1	0	1	register [1525]	
1	1	0	register [1526]	
1	1	1	register [1527]	MSB

Table 45: 3-bit LUT13 Truth Table

IN2	IN1	IN0	OUT	
0	0	0	register [1560]	LSB
0	0	1	register [1561]	
0	1	0	register [1562]	
0	1	1	register [1563]	
1	0	0	register [1564]	
1	0	1	register [1565]	
1	1	0	register [1566]	
1	1	1	register [1567]	MSB

SLG46827-A

Auto AEC-Q100 Qualified GreenPAK
Programmable Mixed-Signal Matrix with In-System Debug

Each macrocell, when programmed for a LUT function, uses a 8-bit register to define their output function:

3-Bit LUT7 is defined by registers [1351:1344]

3-Bit LUT8 is defined by registers [1383:1376]

3-Bit LUT9 is defined by registers [1423:1416]

3-Bit LUT10 is defined by registers [1455:1448]

3-Bit LUT11 is defined by registers [1495:1488]

3-Bit LUT12 is defined by registers [1527:1520]

3-Bit LUT13 is defined by registers [1567:1560]

8.2 CNT/DLY/FSM TIMING DIAGRAMS

8.2.1 Delay Mode CNT/DLY0 to CNT/DLY7

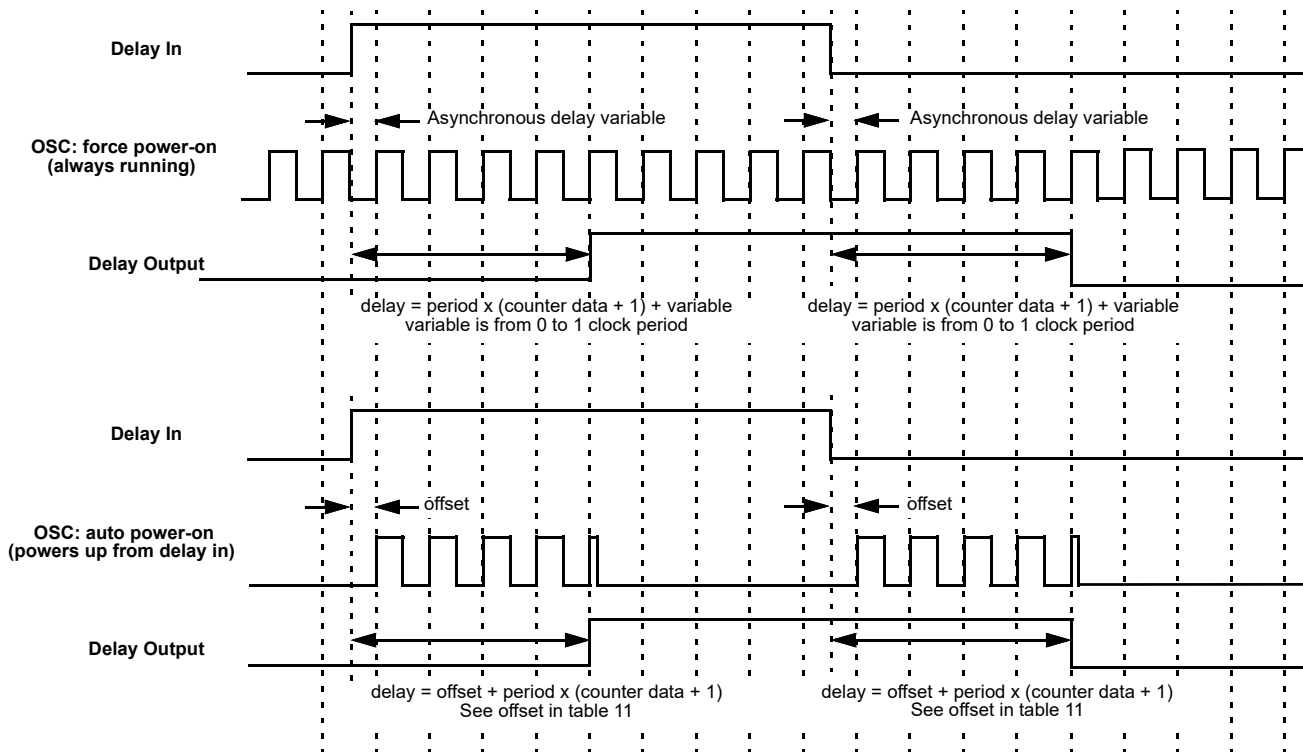

Figure 36: Delay Mode Timing Diagram, Edge Select: Both, Counter Data: 3

SLG46827-A

Auto AEC-Q100 Qualified GreenPAK
Programmable Mixed-Signal Matrix with In-System Debug

The macrocell shifts the respective edge to a set time and restarts by appropriate edge. It works as a filter if the input signal is shorter than the delay time.

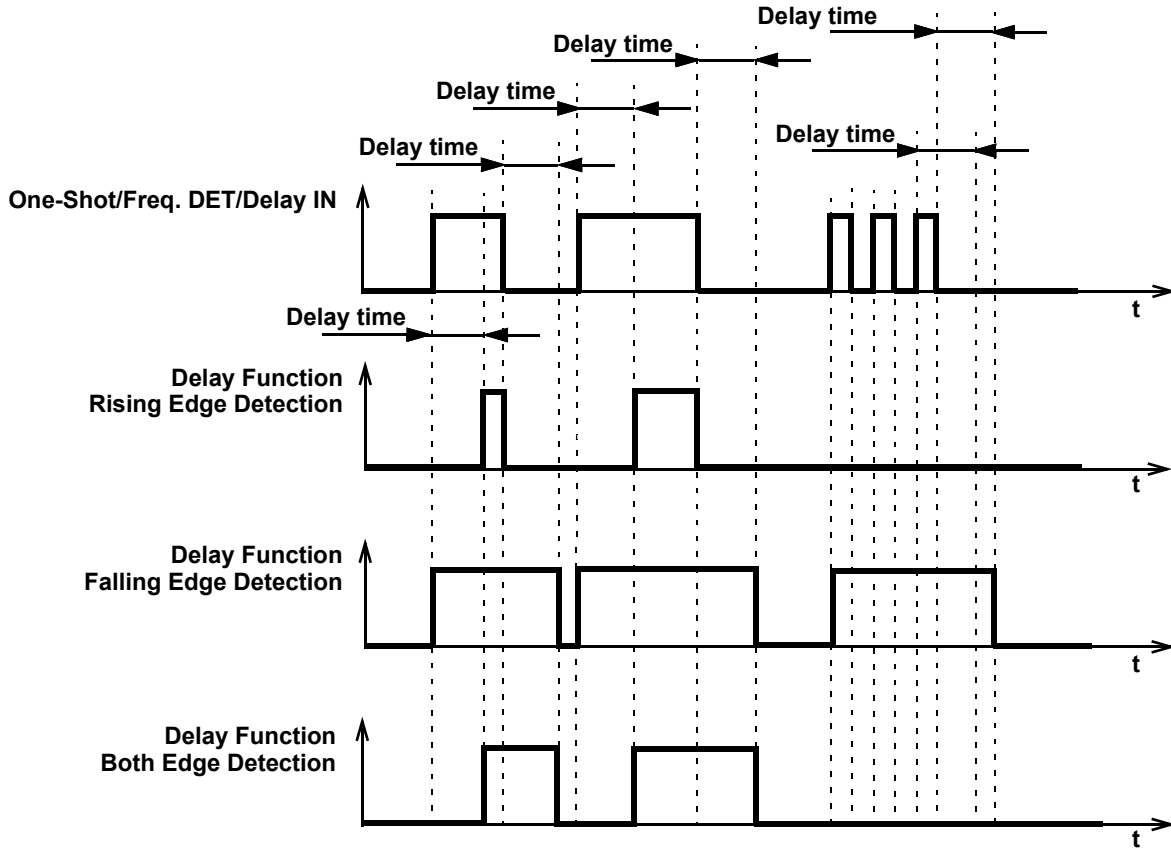

Figure 37: Delay Mode Timing Diagram for Different Edge Select Modes

8.2.2 Count Mode (Count Data: 3), Counter Reset (Rising Edge Detect) CNT/DLY0 to CNT/DLY7

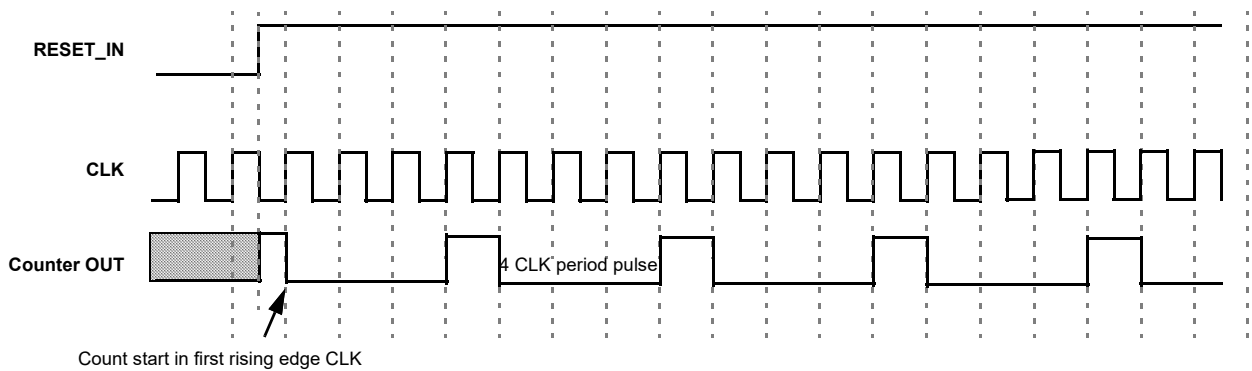

Figure 38: Counter Mode Timing Diagram without Two DFFs Synced Up

SLG46827-A

Auto AEC-Q100 Qualified GreenPAK
 Programmable Mixed-Signal Matrix with In-System Debug

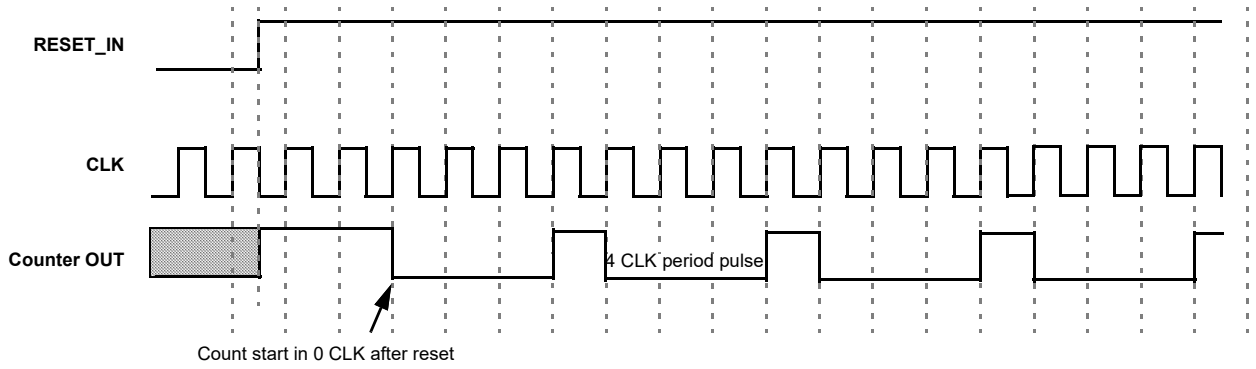

Figure 39: Counter Mode Timing Diagram with Two DFFs Synced Up

SLG46827-A

Auto AEC-Q100 Qualified GreenPAK
Programmable Mixed-Signal Matrix with In-System Debug

8.2.3 One-Shot Mode CNT/DLY0 to CNT/DLY7

This macrocell will generate a pulse whenever a selected edge is detected on its input. Register bits set the edge selection. The pulse width determines by counter data and clock selection properties.

The output pulse polarity (non-inverted or inverted) is selected by register bit. Any incoming edges will be ignored during the pulse width generation. The following diagram shows one-shot function for non-inverted output.

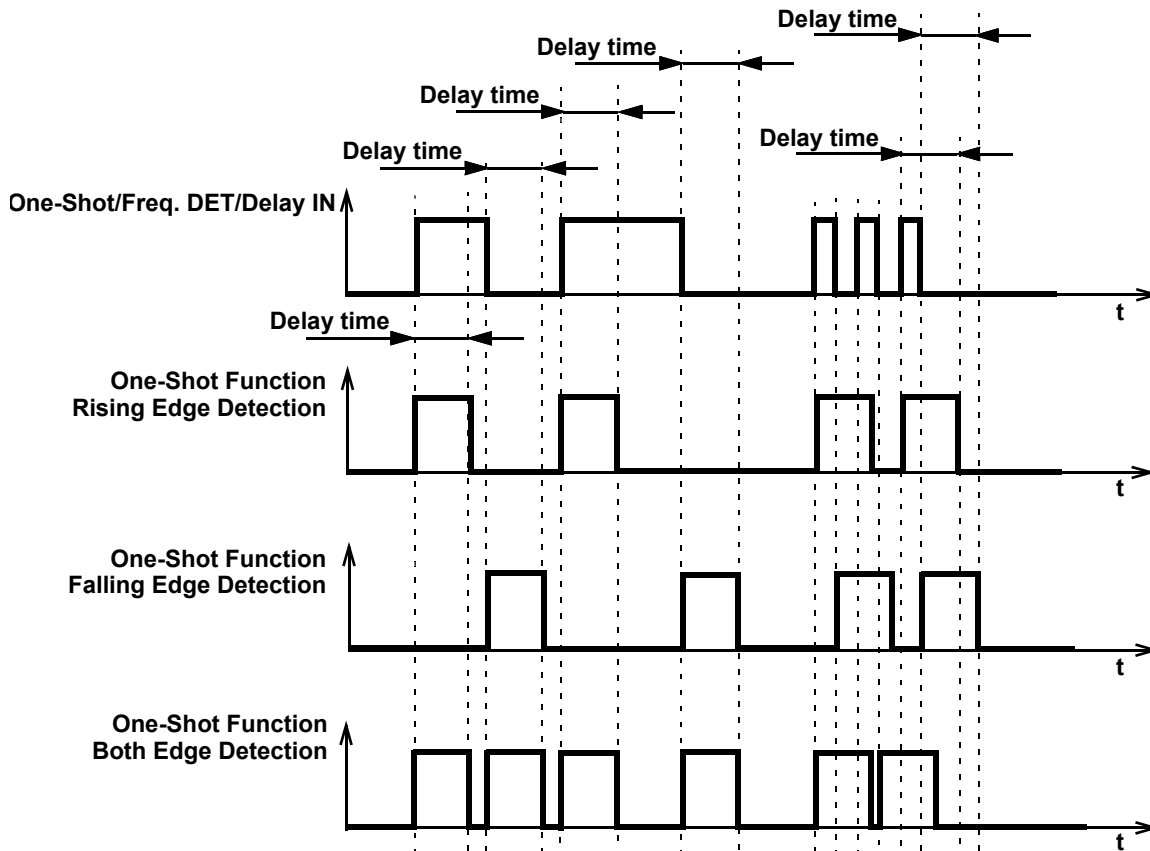

Figure 40: One-Shot Function Timing Diagram

This macrocell generates a high level pulse with a set width (defined by counter data) when detecting the respective edge. It does not restart while pulse is high.

8.2.4 Frequency Detection Mode CNT/DLY0 to CNT/DLY7

Rising Edge: The output goes high if the time between two successive edges is less than the delay. The output goes low if the second rising edge has not come after the last rising edge in specified time.

Falling Edge: The output goes high if the time between two falling edges is less than the set time. The output goes low if the second falling edge has not come after the last falling edge in specified time.

Both Edge: The output goes high if the time between the rising and falling edges is less than the set time, which is equivalent to the length of the pulse. The output goes low if after the last rising/falling edge and specified time, the second edge has not come.

SLG46827-A

Auto AEC-Q100 Qualified GreenPAK
Programmable Mixed-Signal Matrix with In-System Debug

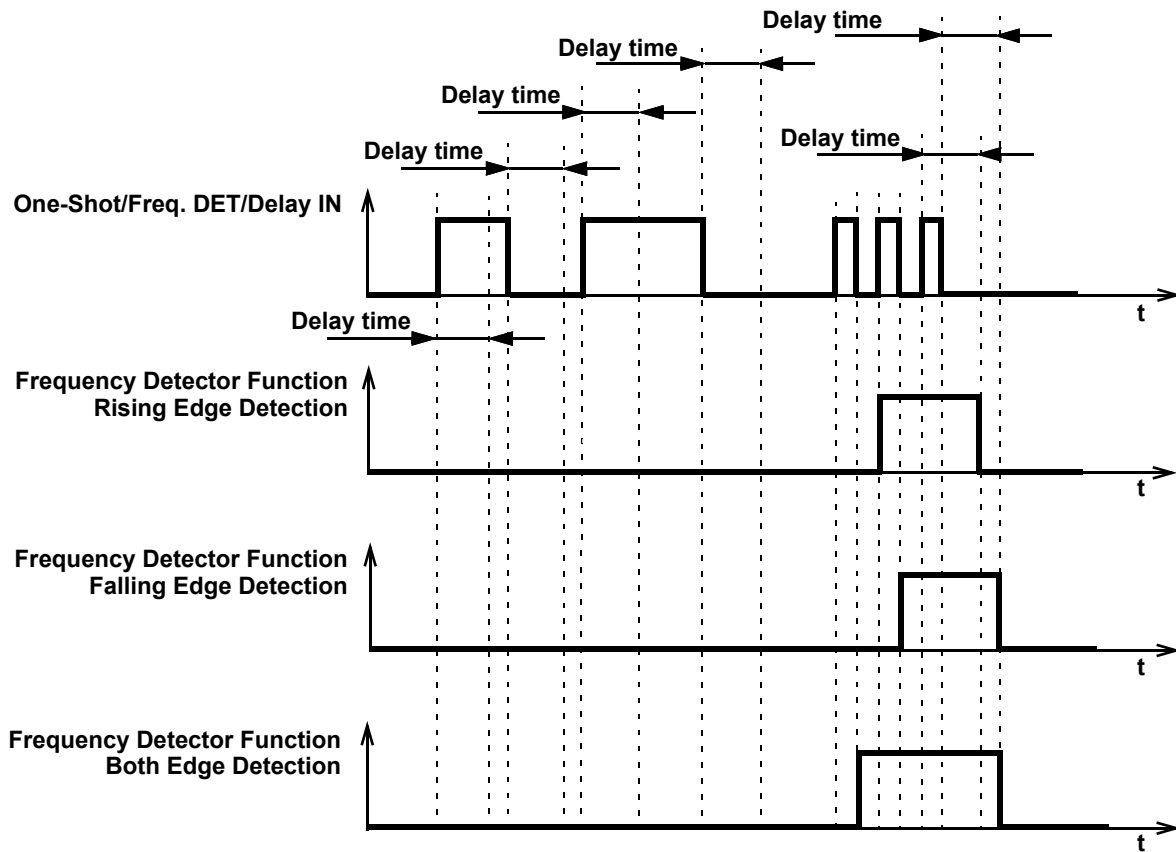

Figure 41: Frequency Detection Mode Timing Diagram

SLG46827-A

Auto AEC-Q100 Qualified GreenPAK
 Programmable Mixed-Signal Matrix with In-System Debug

8.2.5 Edge Detection Mode CNT/DLY1 to CNT/DLY7

The macrocell generates high level short pulse when detecting the respective edge. See [Table 12](#).

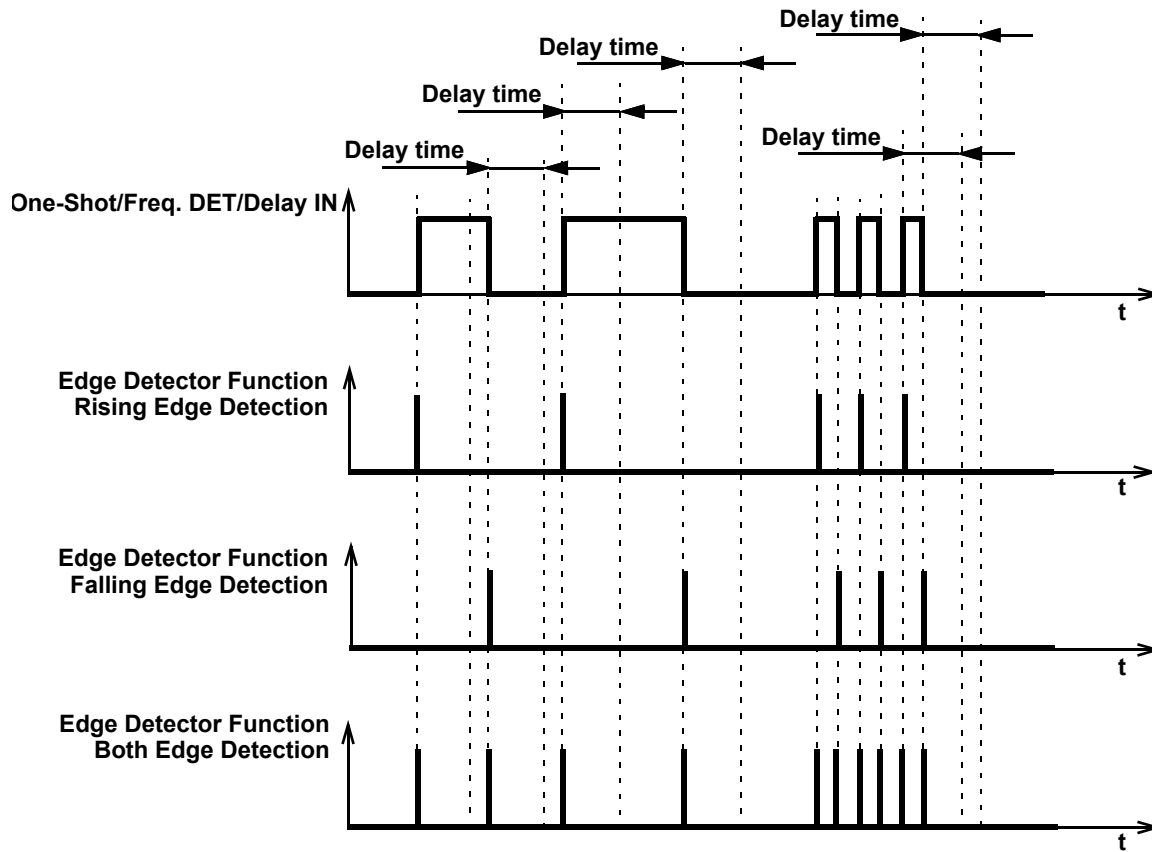

Figure 42: Edge Detection Mode Timing Diagram

SLG46827-A

Auto AEC-Q100 Qualified GreenPAK
Programmable Mixed-Signal Matrix with In-System Debug

8.2.6 Delayed Edge Detection Mode CNT/DLY0 to CNT/DLY7

In Delayed Edge Detection Mode, High level short pulses are generated on the macrocell output after the configured delay time, if the corresponding edge was detected on the input.

If the input signal is changed during the set delay time, the pulse will not be generated. See Figure 43.

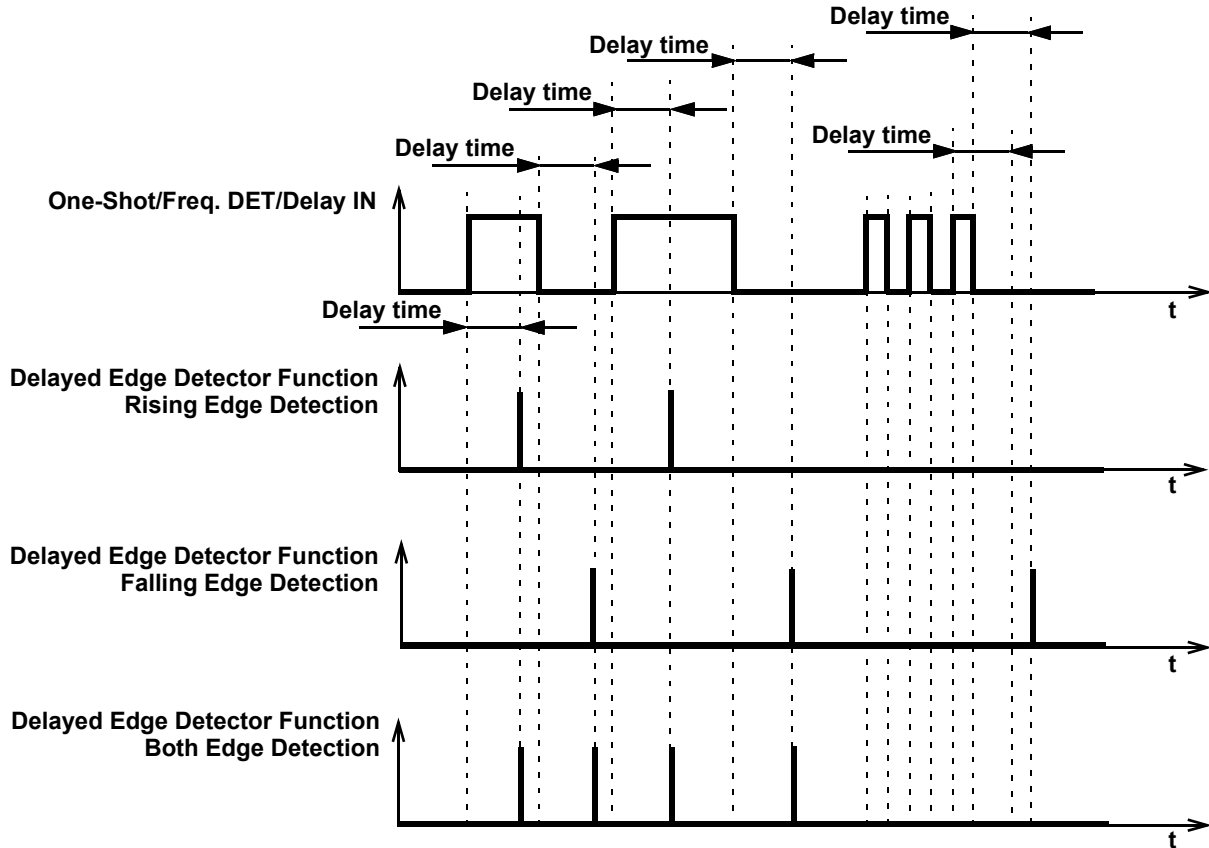

Figure 43: Delayed Edge Detection Mode Timing Diagram

SLG46827-A

Auto AEC-Q100 Qualified GreenPAK
Programmable Mixed-Signal Matrix with In-System Debug

8.2.7 CNT/FSM Mode CNT/DLY0

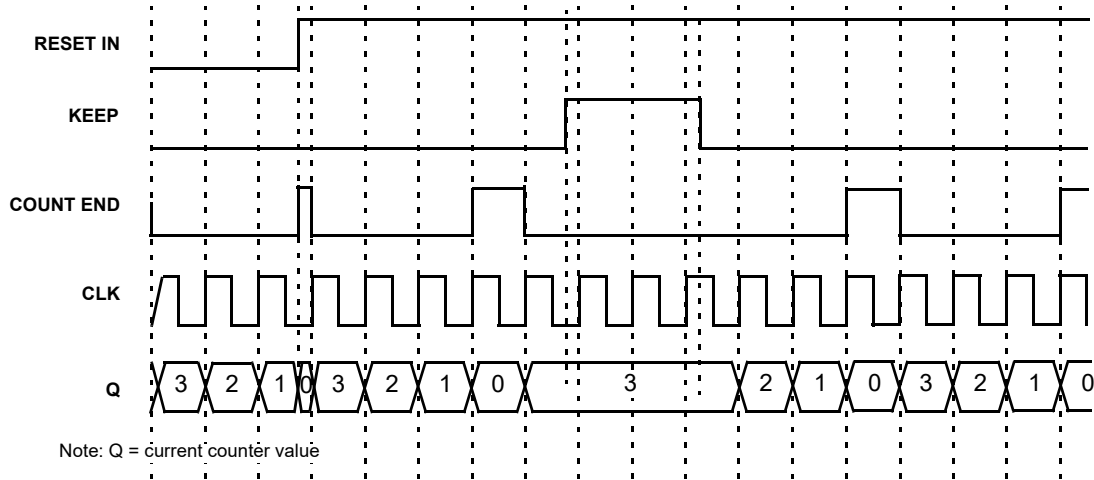

Figure 44: CNT/FSM Timing Diagram (Reset Rising Edge Mode, Oscillator is Forced On, UP = 0) for Counter Data = 3

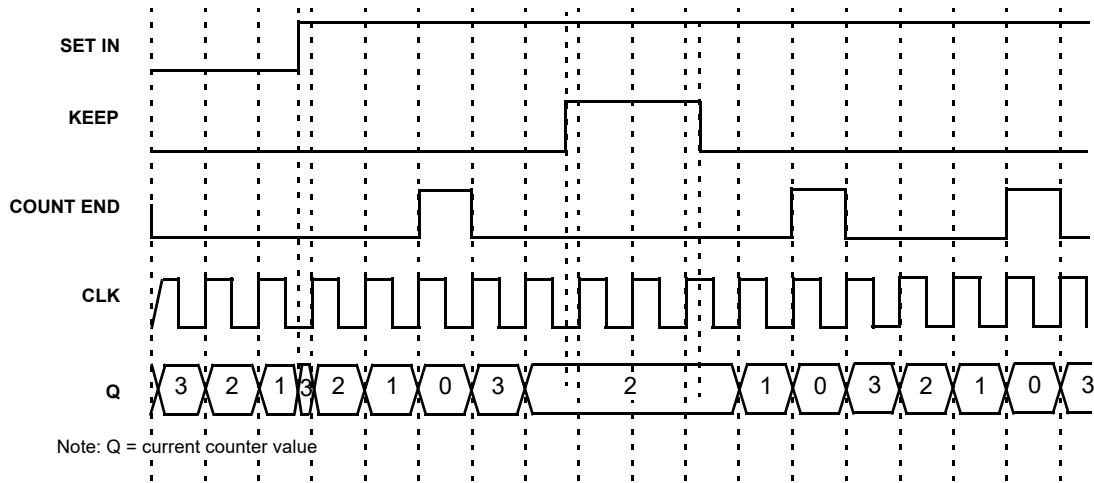

Figure 45: CNT/FSM Timing Diagram (Set Rising Edge Mode, Oscillator is Forced On, UP = 0) for Counter Data = 3

SLG46827-A

Auto AEC-Q100 Qualified GreenPAK
 Programmable Mixed-Signal Matrix with In-System Debug

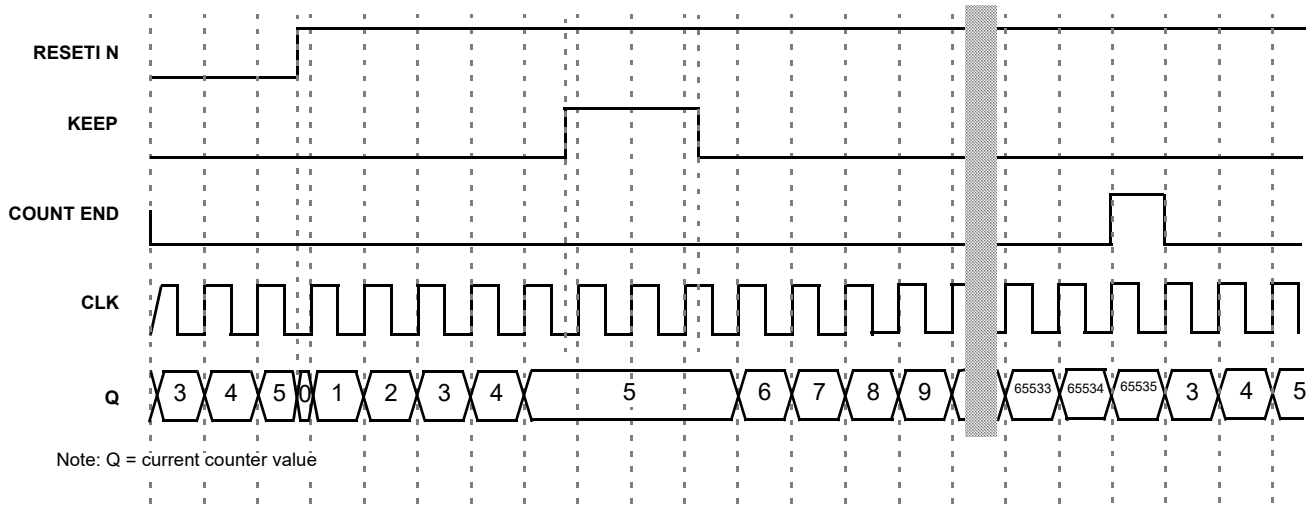

Figure 46: CNT/FSM Timing Diagram (Reset Rising Edge Mode, Oscillator is Forced On, UP = 1) for Counter Data = 3

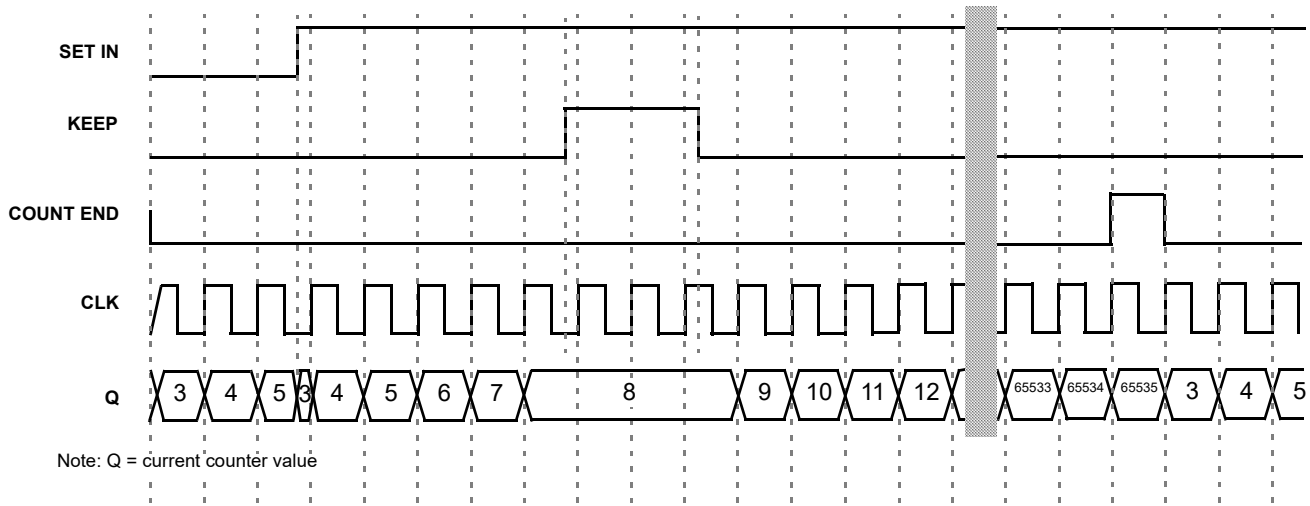

Figure 47: CNT/FSM Timing Diagram (Set Rising Edge Mode, Oscillator is Forced On, UP = 1) for Counter Data = 3

SLG46827-A

Auto AEC-Q100 Qualified GreenPAK Programmable Mixed-Signal Matrix with In-System Debug

8.2.8 Difference in Counter Value for Counter, Delay, One-Shot, and Frequency Detect Modes

There is a difference in counter value for Counter and Delay/One-Shot/Frequency Detect modes. The counter value is shifted for two rising edges of the clock signal in Delay/One-Shot/Frequency Detect modes compared to Counter mode. See [Figure 48](#).

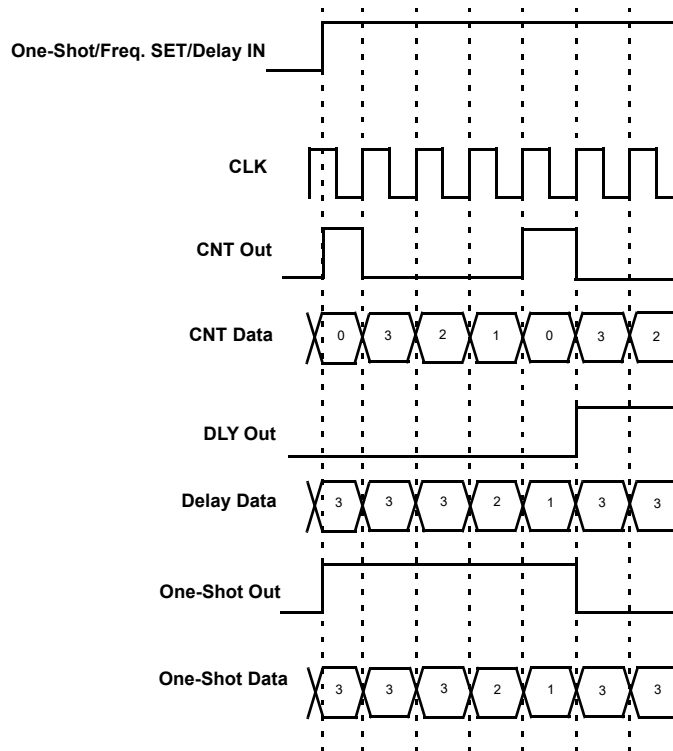

Figure 48: Counter Value, Counter Data = 3

8.3 4-BIT LUT OR DFF/LATCH WITH 16-BIT COUNTER/DELAY MACROCELL

There is one macrocell that can serve as either 4-bit LUT/D Flip-Flop or as 16-bit Counter/Delay.

When used to implement LUT function, the 4-bit LUT takes in four input signals from the Connection Matrix and produces a single output, which goes back into the Connection Matrix or can be connected to CNT/DLY's input or LUT/DFF's input.

When used to implement D Flip-Flop function, the two input signals from the connection matrix go to the data (D) and clock (CLK) inputs for the Flip-Flop, with the output going back to the connection matrix.

When used to implement 16-Bit Counter/Delay function, two of the four input signals from the connection matrix go to the external clock (EXT_CLK) and reset (DLY_IN/CNT Reset) for the Counter/Delay, with the output going back to the connection matrix.

This macrocell has an optional Finite State Machine (FSM) function. There are two additional matrix inputs for Up and Keep to support FSM functionality.

This macrocell can also operate in a one-shot mode, which will generate an output pulse of user-defined width.

This macrocell can also operate in a frequency detection.

This macrocell can have its active count value read via I²C. See Section [15.7.1](#) for further details.

Note: After two DFF – counters initialize with counter data = 0 after POR.

SLG46827-A

Auto AEC-Q100 Qualified GreenPAK
Programmable Mixed-Signal Matrix with In-System Debug

Initial state = 1 – counters initialize with counter data = 0 after POR.

Initial state = 0 And After two DFF is bypass – counters initialize with counter data after POR.

8.3.1 4-Bit LUT or 16-Bit CNT/DLY Block Diagram

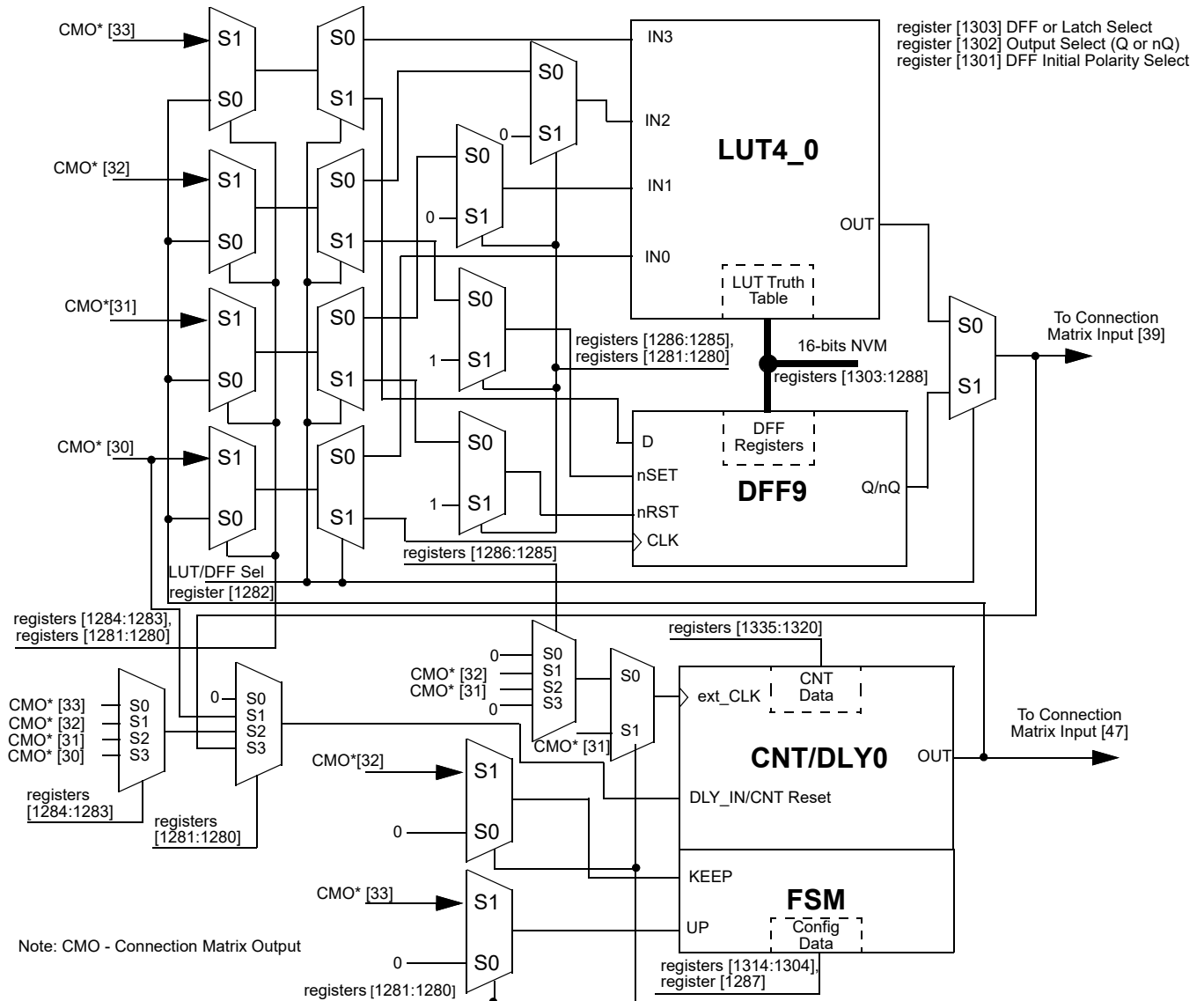

Figure 49: 4-bit LUT0 or CNT/DLY0

SLG46827-A

Auto AEC-Q100 Qualified GreenPAK Programmable Mixed-Signal Matrix with In-System Debug

8.3.2 4-Bit LUT or 16-Bit Counter/Delay Macrocells Used as 4-Bit LUTs

Table 46: 4-bit LUT0 Truth Table

IN3	IN2	IN1	IN0	OUT	
0	0	0	0	register [1288]	LSB
0	0	0	1	register [1289]	
0	0	1	0	register [1290]	
0	0	1	1	register [1291]	
0	1	0	0	register [1292]	
0	1	0	1	register [1293]	
0	1	1	0	register [1294]	
0	1	1	1	register [1295]	
1	0	0	0	register [1296]	
1	0	0	1	register [1297]	
1	0	1	0	register [1298]	
1	0	1	1	register [1299]	
1	1	0	0	register [1300]	
1	1	0	1	register [1301]	
1	1	1	0	register [1302]	
1	1	1	1	register [1303]	MSB

This macrocell, when programmed for a LUT function, uses a 16-bit register to define their output function:

4-Bit LUT0 is defined by registers [1303:1288]

Table 47: 4-bit LUT Standard Digital Functions

Function	MSB															LSB
AND-4	1	0	0	0	0	0	0	0	0	0	0	0	0	0	0	0
NAND-4	0	1	1	1	1	1	1	1	1	1	1	1	1	1	1	1
OR-4	1	1	1	1	1	1	1	1	1	1	1	1	1	1	1	0
NOR-4	0	0	0	0	0	0	0	0	0	0	0	0	0	0	0	1
XOR-4	0	1	1	0	1	0	0	1	1	0	0	1	0	1	1	0
XNOR-4	1	0	0	1	0	1	1	0	0	1	1	0	1	0	0	1

SLG46827-A

Auto AEC-Q100 Qualified GreenPAK
Programmable Mixed-Signal Matrix with In-System Debug

8.4 WAKE AND SLEEP CONTROLLER

The SLG46827-A has a Wake and Sleep (WS) function for ACMP0H and ACMP1H. The macrocell CNT/DLY0 can be reconfigured for this purpose registers [1305:1304] = 11 and register [1316] = 1. The WS serves for power saving, it allows to switch on and off selected ACMPs on selected bit of 16-bit counter.

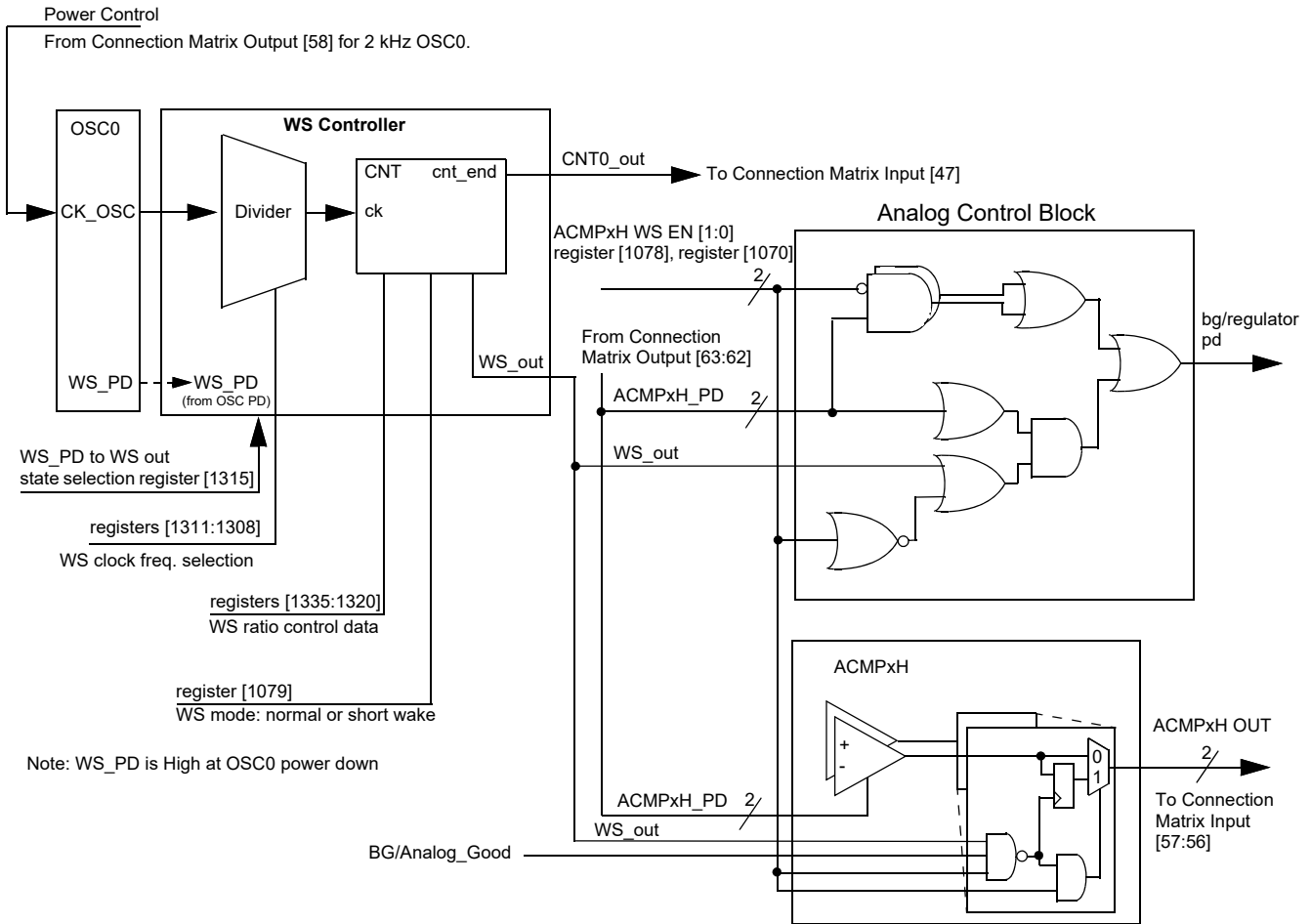

Figure 50: Wake and Sleep Controller

SLG46827-A

Auto AEC-Q100 Qualified GreenPAK
Programmable Mixed-Signal Matrix with In-System Debug

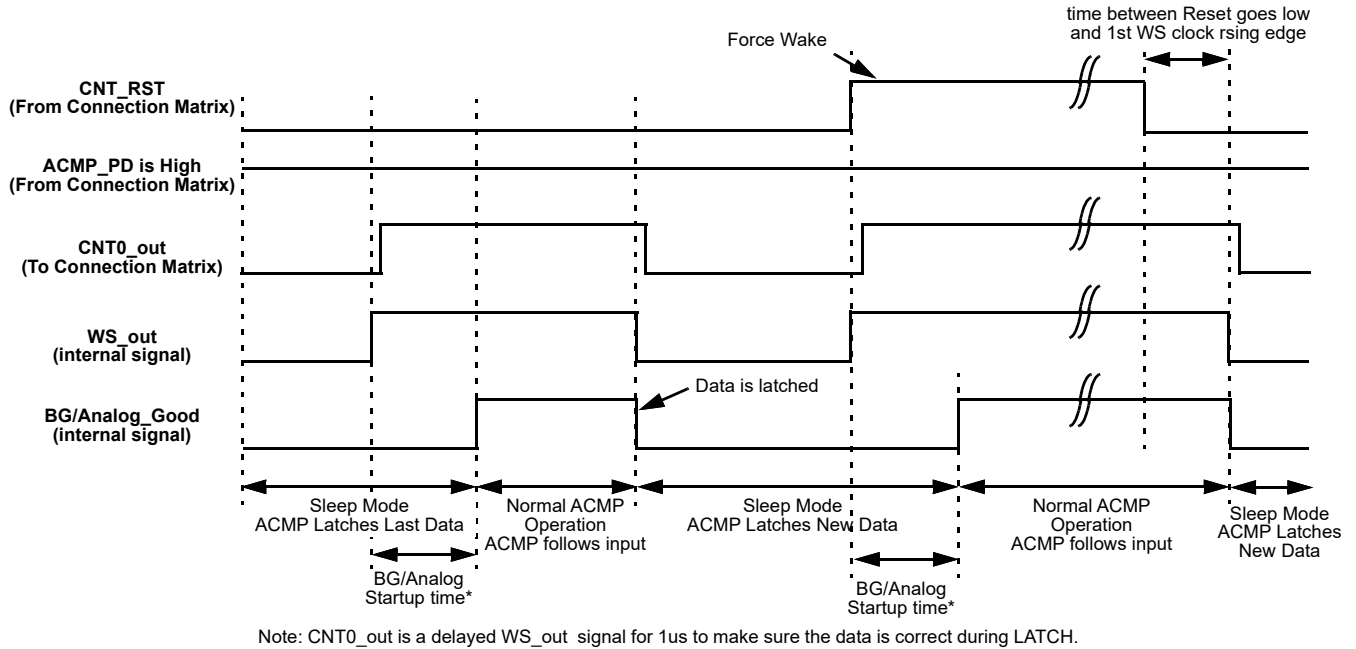

Figure 51: Wake and Sleep Timing Diagram, Normal Wake Mode, Counter Reset is Used

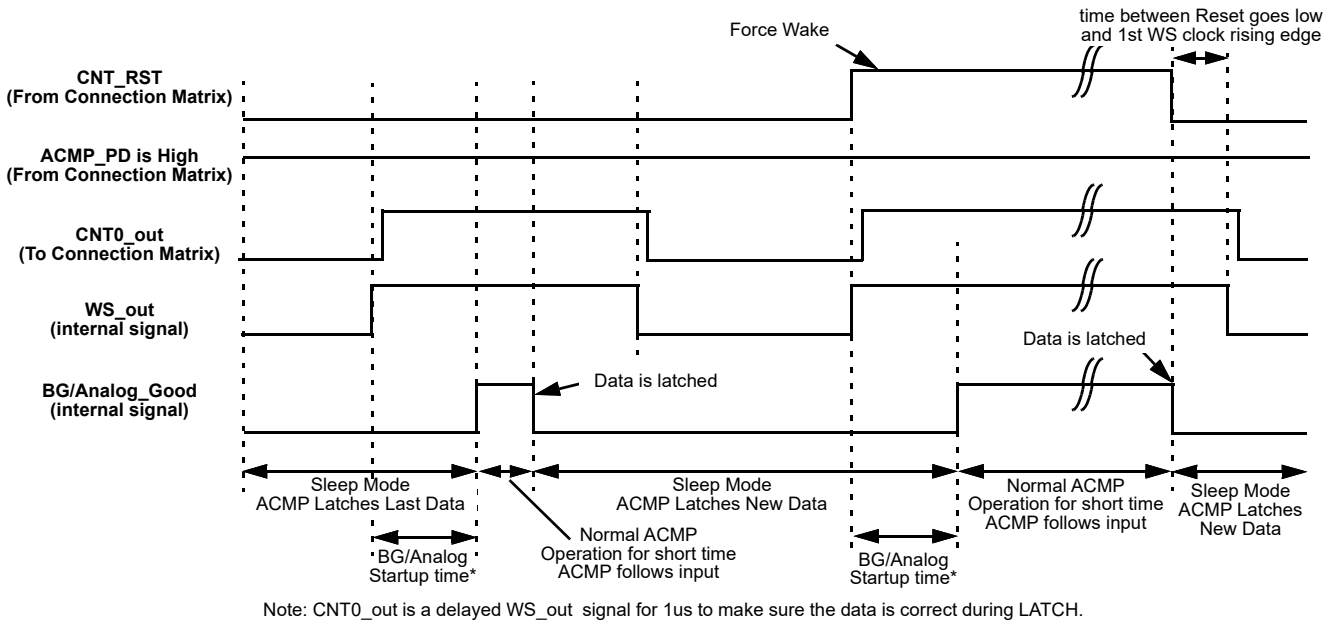
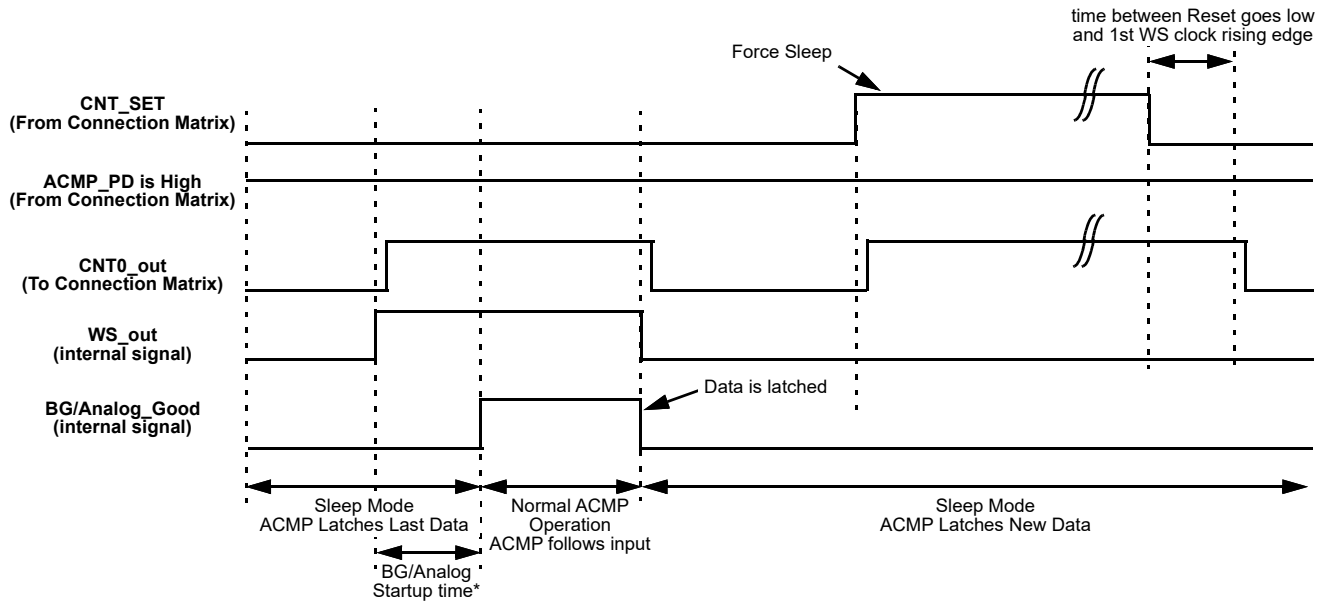

Figure 52: Wake and Sleep Timing Diagram, Short Wake Mode, Counter Reset is Used

SLG46827-A

Auto AEC-Q100 Qualified GreenPAK
Programmable Mixed-Signal Matrix with In-System Debug



Note: CNT0_out is a delayed WS_out signal for 1 us to make sure the data is correct during LATCH.

Figure 53: Wake and Sleep Timing Diagram, Normal Wake Mode, Counter Set is Used

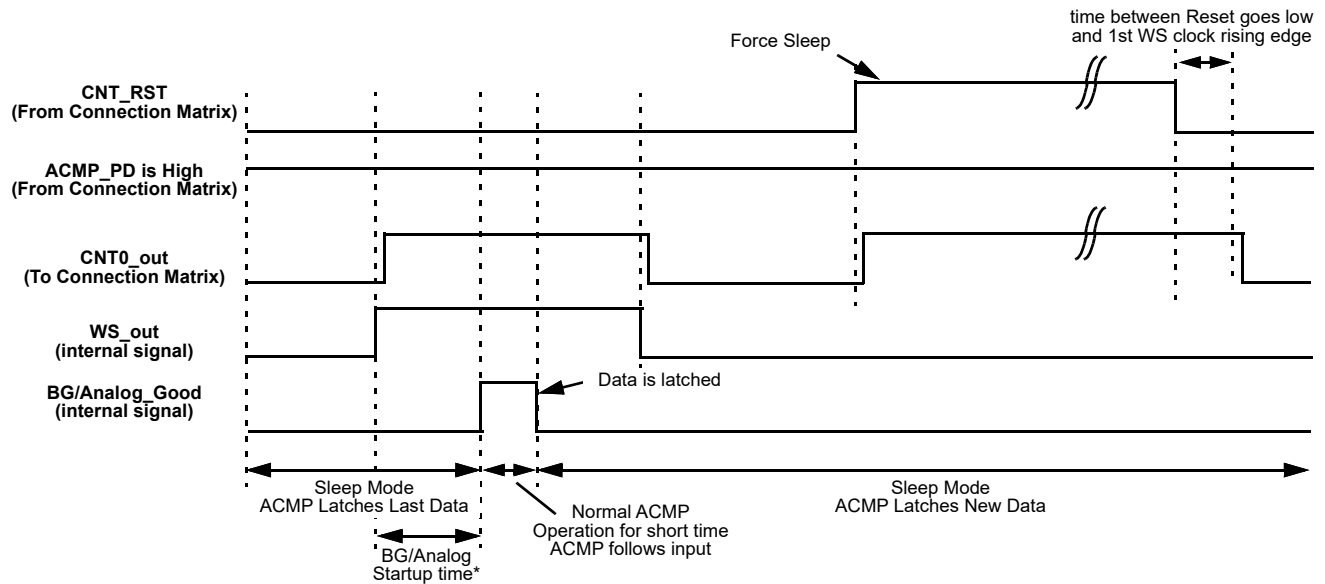

Note: CNT0_out is a delayed WS_out signal for 1us to make sure the data is correct during LATCH.

Figure 54: Wake and Sleep Timing Diagram, Short Wake Mode, Counter Set is Used

Note: If low power BG is powered on/off by WS, the wake time should be longer than 2.1 ms. The BG/analog start up time will take maximal 2 ms. If low power BG is always on, OSC0 period is longer than required wake time. The short wake mode can be used to reduce the current consumption.

To use any ACMPxH under WS controller, the following settings must be done:

- ACMPxH Power Up Input from matrix = 1 (for each ACMPxH separately);

SLG46827-A

Auto AEC-Q100 Qualified GreenPAK Programmable Mixed-Signal Matrix with In-System Debug

- CNT/DLY0 must be set to Wake and Sleep Controller function (for all ACMPxH);
- Register WS → enable (for each ACMPxH separately);
- CNT/DLY0 set/reset input = 0 (for all ACMPxH).

OSC0 is used to clock WS. The user can select a period of time while the ACMPxH is sleeping in a range of 1 - 65535 clock cycles. Before they are sent to sleep, their outputs are latched, so the ACMPs remain their state (High or Low) while sleeping.

WS controller has the following settings:

- Wake and Sleep Output State (High/Low)
 - If OSC is powered off (Power-down option is selected; Power-down input = 1) and Wake and Sleep Output State = High, the ACMPxH is continuously on.
 - If OSC is powered off (Power-down option is selected; Power-down input = 1) and Wake and Sleep Output State = Low, the ACMPxH is continuously off.
 - Both cases WS function is turned off.
- Counter Data (Range: 1 to 65535)
 - User can select wake and sleep ratio of the ACMP; counter data = sleep time, one clock = wake time.
- Q mode - defines the state of WS counter data when Set/Reset signal appears
 - Reset - when active signal appears, the WS counter will reset to zero and High level signal on its output will turn on the ACMPs. When Reset signal goes out, the WS counter will go Low and turn off the ACMPxH until the counter counts up to the end.
 - Set - when active signal appears, the WS counter will stop and Low level signal on its output will turn off the ACMPxH. When Set signal goes out, the WS counter will go on counting and High level signal will turn on the ACMPxH while counter is counting up to the end.

Note: The OSC0 matrix power-down to control ACMP WS is not supported for short wait time option.

- Edge Select defines the edge for Q mode
 - High level Set/Reset - switches mode Set/Reset when level is High

Note: Q mode operates only in case of "High Level Set/Reset".

- Wake time selection - time required for wake signal to turn the ACMPxH on

Normal Wake Time - when WS signal is High, it takes BG/analog start up time to turn the ACMPs on. They will stay on until WS signal is Low again. Wake time is one clock period. It should be longer than BG turn on time and minimal required comparing time of the ACMP.

Short Wake Time - when WS signal is High, it takes BG/analog start up time to turn the ACMPs on. They will stay on for 1 μ s and turn off regardless of WS signal. The WS signal width does not matter.

- Keep - pauses counting while Keep = 1
- Up - reverses counting
 - If Up = 1, CNT is counting up from user selected value to 65535.
 - If Up = 0, CNT is counting down from user selected value to 0.

9 Analog Comparators

There are four General Purpose Rail-to-Rail Analog Comparator (ACMP) macrocells in the SLG46827-A. In order for the ACMP cells to be used in a GreenPAK design, the power up signals (ACMP0H PWR UP, ACMP1H PWR UP, ACMP2L PWR UP, and ACMP3L PWR UP) need to be active. By connecting to signals coming from the Connection Matrix, it is possible to have each ACMP be on continuously, off continuously, or switched on periodically based on a digital signal coming from the Connection Matrix. When ACMP is powered down, output is low.

Two of the four General Purpose Rail-to-Rail Analog Comparators are optimized for high speed operation (ACMP0H and ACMP1H), and two of the four are optimized for low power operation (ACMP2L and ACMP3L).

Each of the ACMP cells has a positive input signal that can be provided by a variety of external sources, and can also have a selectable gain stage before connection to the analog comparator. Each of the ACMP cells has a negative input signal that is either created from an internal Vref or provided by way of the external sources.

PWR UP = 1 → ACMP is powered up.

PWR UP = 0 → ACMP is powered down.

During power-up, the ACMP output will remain LOW, and then become valid 51.4 μs (max), after power up signal goes high for ACMP0H and ACMP1H, and become valid 326.6 μs (max), after power up signal goes high for ACMP2L and ACMP3L. Input bias current < 1 nA (typ). The Gain divider is unbuffered and consists of 1 MΩ resistors.

Each High Speed ACMP (ACMP0H and ACMP1H) has an optional Rail-to-Rail Input Buffer, which can be used along with the Gain divider to increase ACMP input resistance. However, Input buffer will increase an input offset voltage.

Each cell also has a hysteresis selection, to offer hysteresis of (0, 32, 64, 192) mV. The hysteresis option is available when using an internal Vref only.

The ACMP0H has an additional option of connecting an internal 100 μA current source to its positive input, register [1071]. It is also possible to connect the 100 μA current source to each next ACMP via an internal analog MUX.

ACMP0H IN+ options are IO14, V_D, internal 100 μA current source

ACMP1H IN+ options are IO13, ACMP0H IN+ MUX output

ACMP2L IN+ options are IO12, ACMP0H IN+ MUX output, ACMP1H IN+ MUX output

ACMP3L IN+ options are IO11, ACMP2L IN+ MUX output, Temp Sensor OUT

SLG46827-A

Auto AEC-Q100 Qualified GreenPAK
Programmable Mixed-Signal Matrix with In-System Debug

9.1 ACMP0H BLOCK DIAGRAM

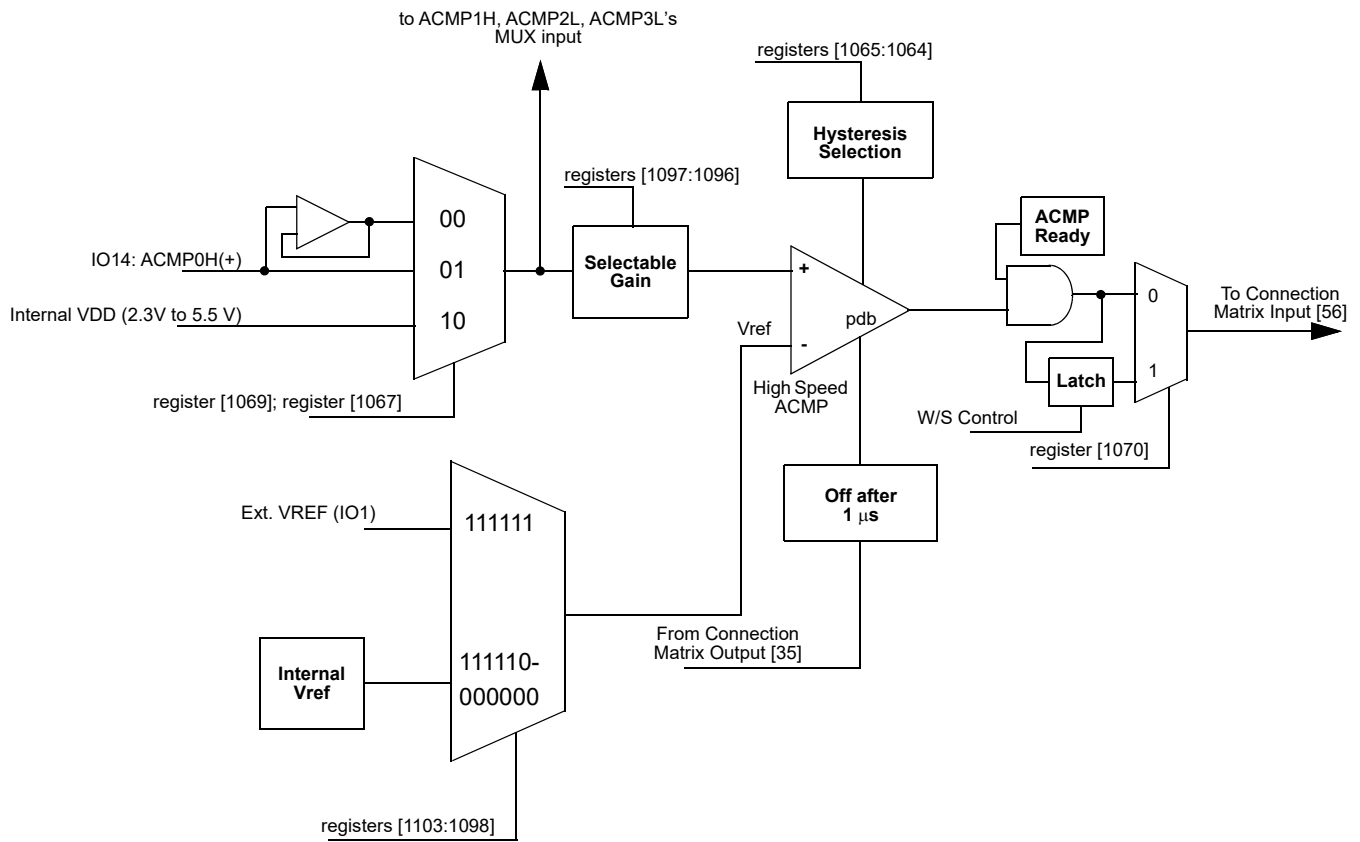

Figure 55: ACMP0H Block Diagram

SLG46827-A

Auto AEC-Q100 Qualified GreenPAK
Programmable Mixed-Signal Matrix with In-System Debug

9.2 ACMP1H BLOCK DIAGRAM

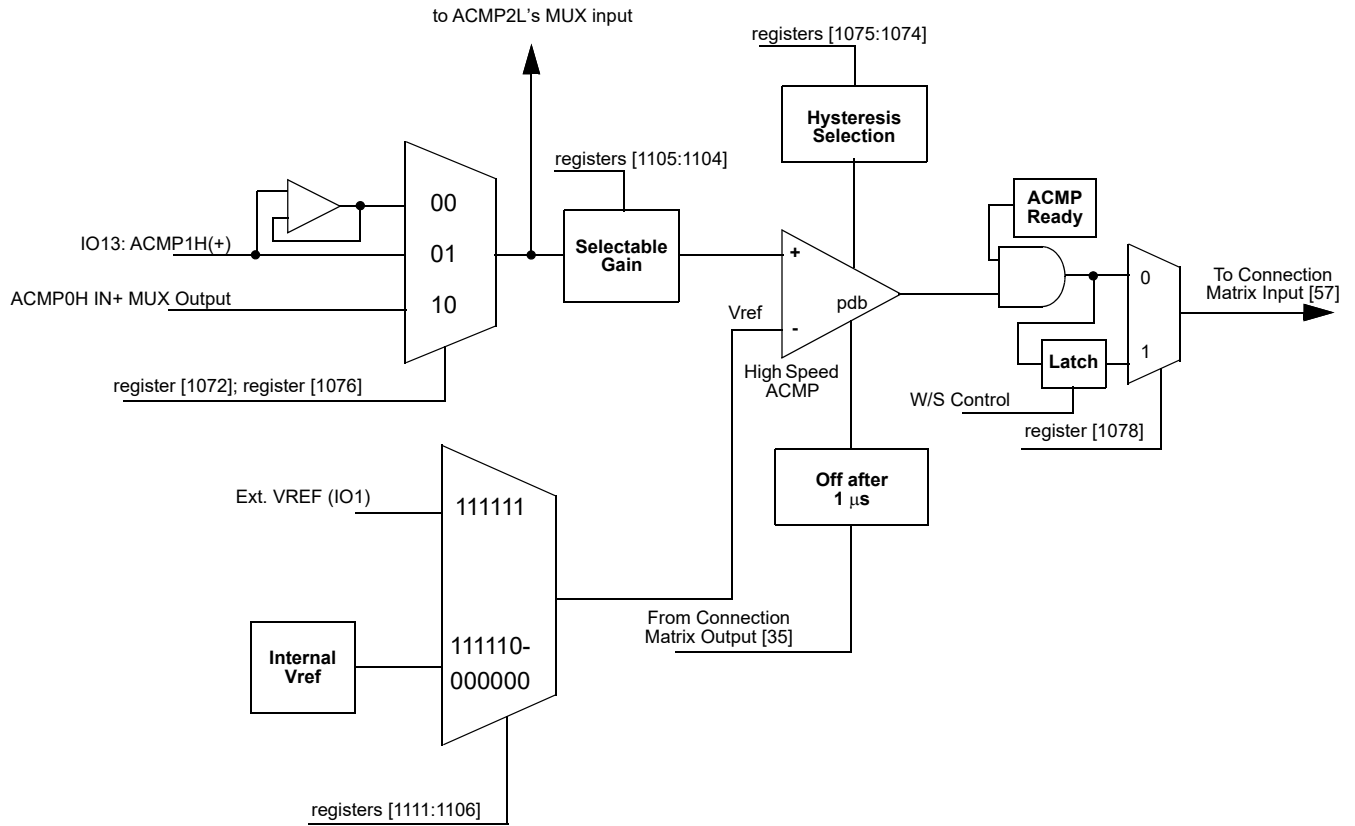

Figure 56: ACMP1H Block Diagram

SLG46827-A

Auto AEC-Q100 Qualified GreenPAK
Programmable Mixed-Signal Matrix with In-System Debug

9.3 ACMP2L BLOCK DIAGRAM

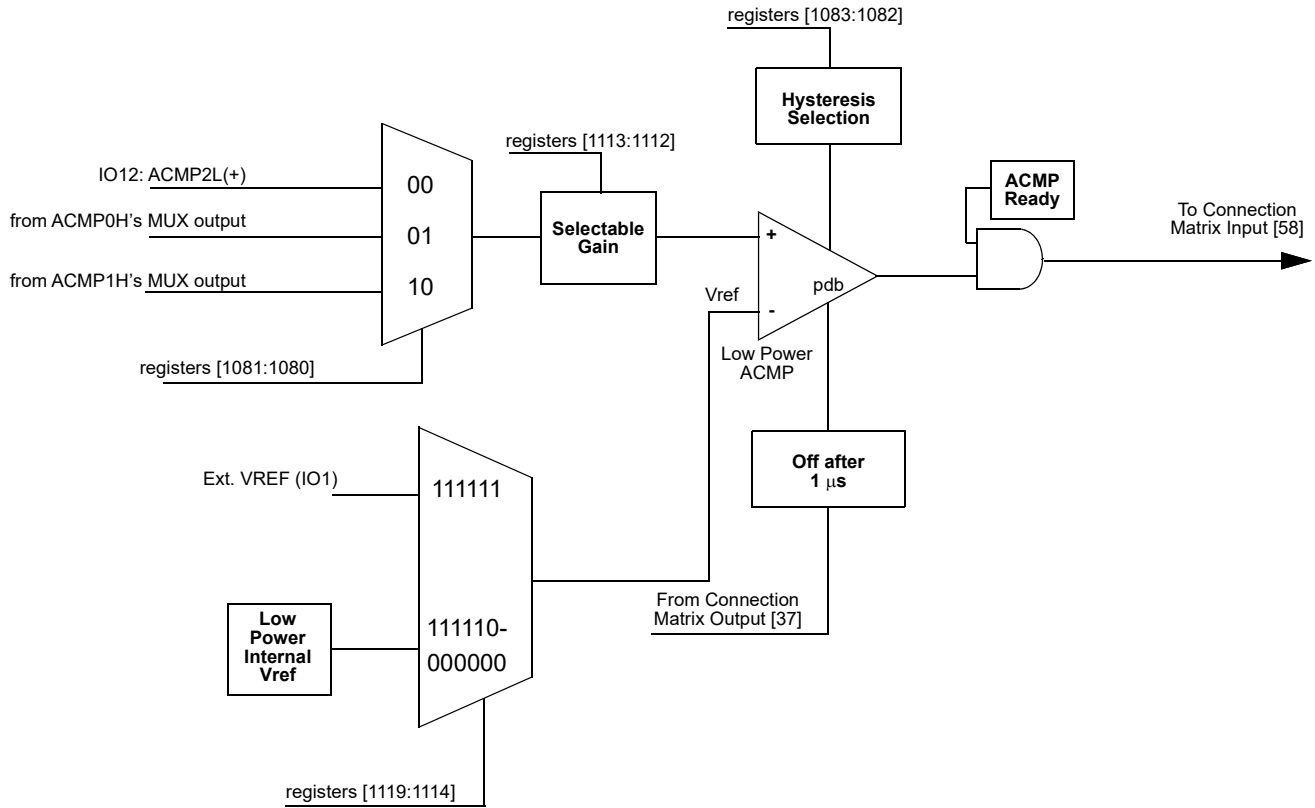

Figure 57: ACMP2L Block Diagram

SLG46827-A

Auto AEC-Q100 Qualified GreenPAK
Programmable Mixed-Signal Matrix with In-System Debug

9.4 ACMP3L BLOCK DIAGRAM

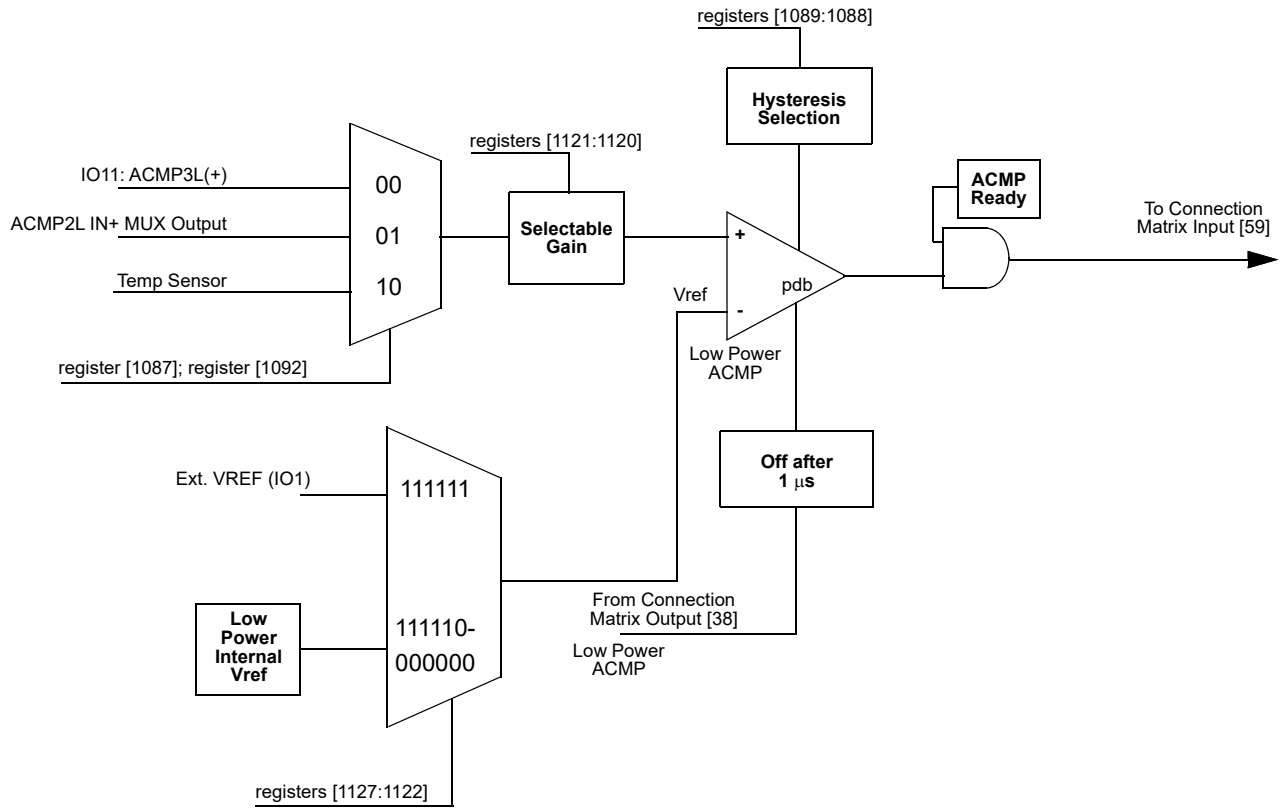

Figure 58: ACMP3L Block Diagram

SLG46827-A

Auto AEC-Q100 Qualified GreenPAK
Programmable Mixed-Signal Matrix with In-System Debug

9.5 ACMP TYPICAL PERFORMANCE

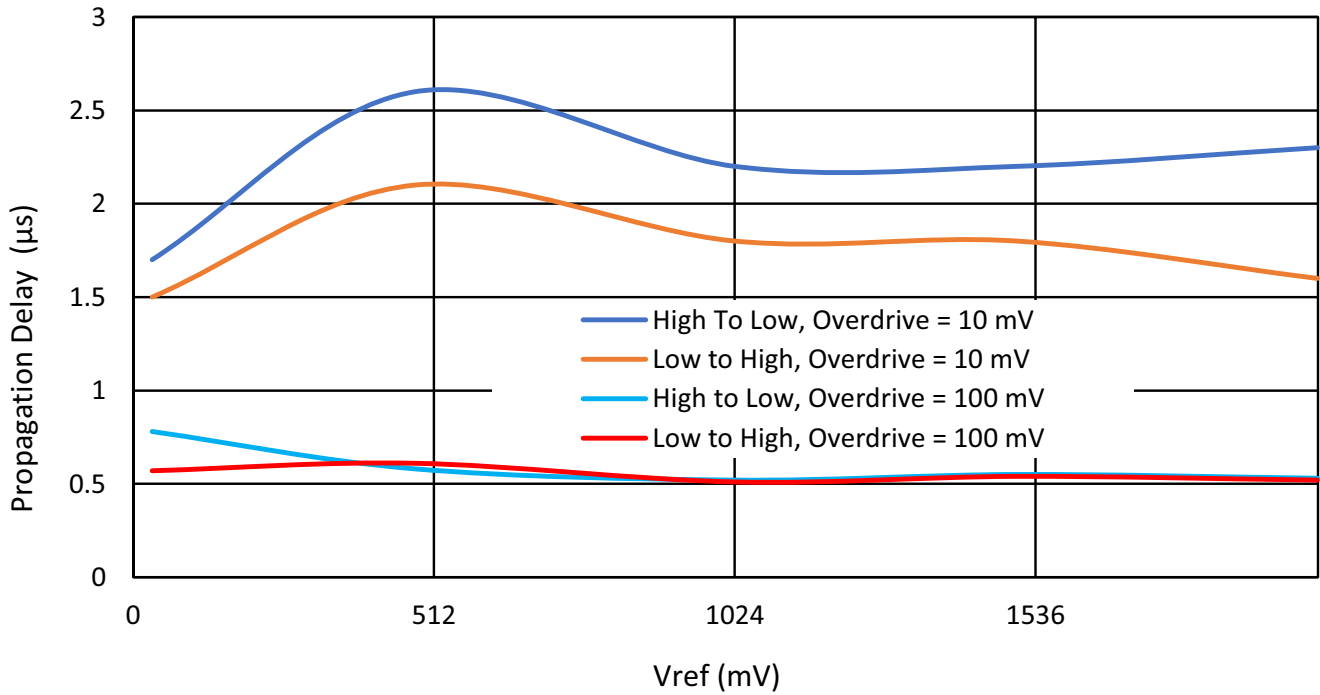

Figure 59: Typical Propagation Delay vs. Vref for ACMPxH at T = 25 °C, Gain = 1, Buffer - Disabled, Hysteresis = 0

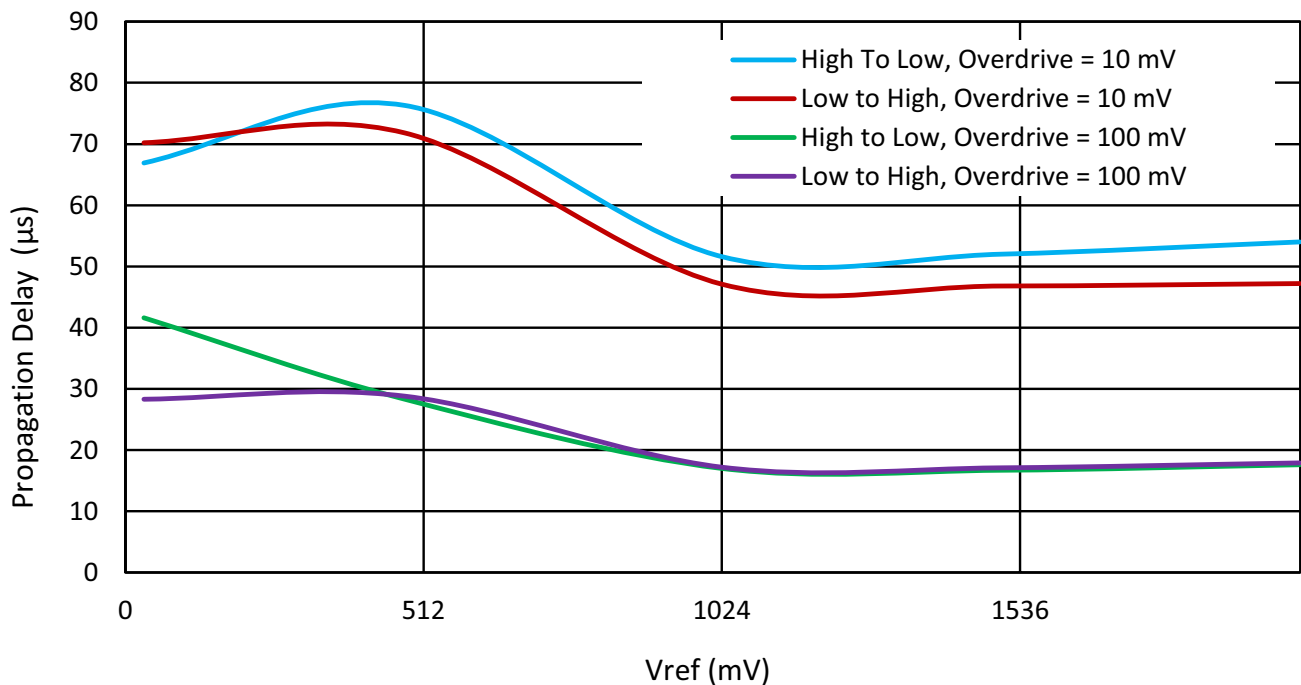

Figure 60: Typical Propagation Delay vs. Vref for ACMPxL at T = 25 °C, Gain = 1, Buffer - Disabled, Hysteresis = 0

SLG46827-A

Auto AEC-Q100 Qualified GreenPAK
Programmable Mixed-Signal Matrix with In-System Debug

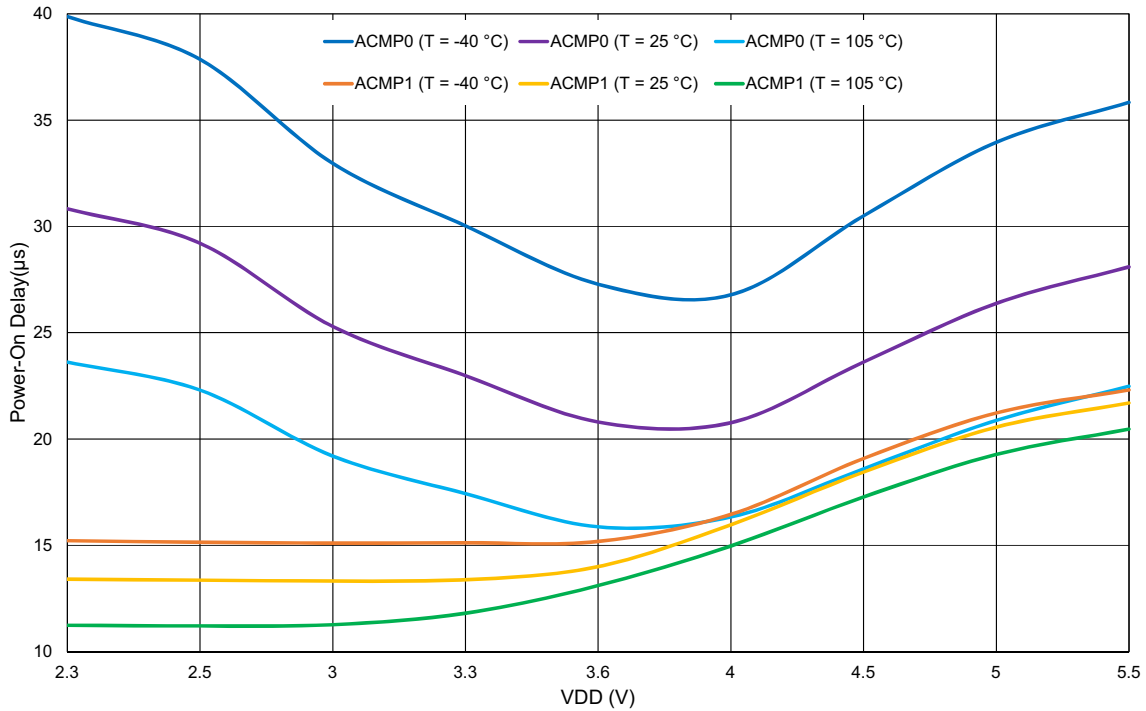

Figure 61: ACMPxH Power-On Delay vs. V_{DD}

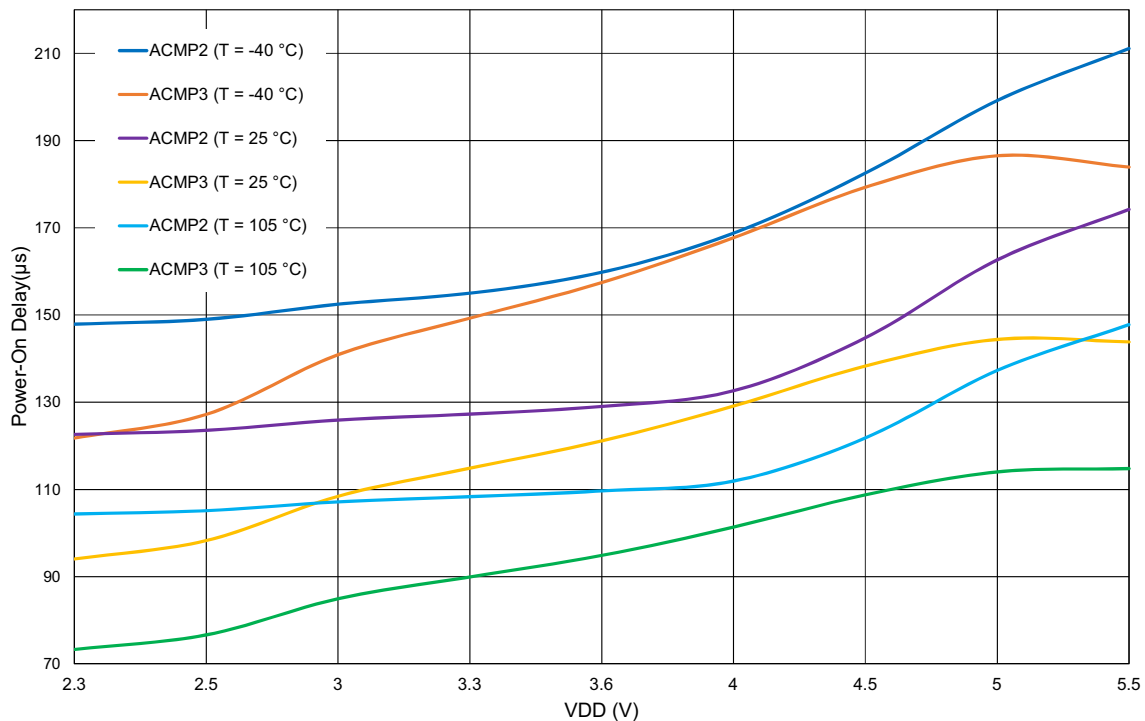

Figure 62: ACMPxL Power-On Delay vs. V_{DD}

SLG46827-A

Auto AEC-Q100 Qualified GreenPAK
 Programmable Mixed-Signal Matrix with In-System Debug

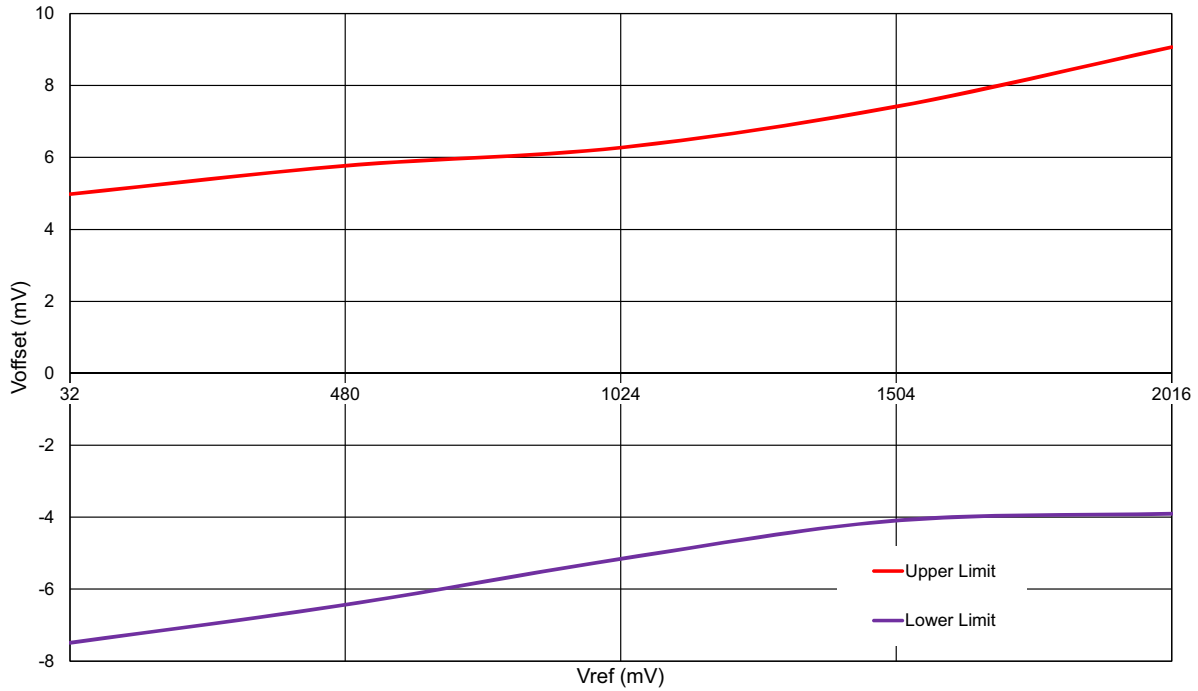

Figure 63: ACMPxH Input Offset Voltage vs. Vref at T = -40 °C to 105 °C, Input Buffer Disabled

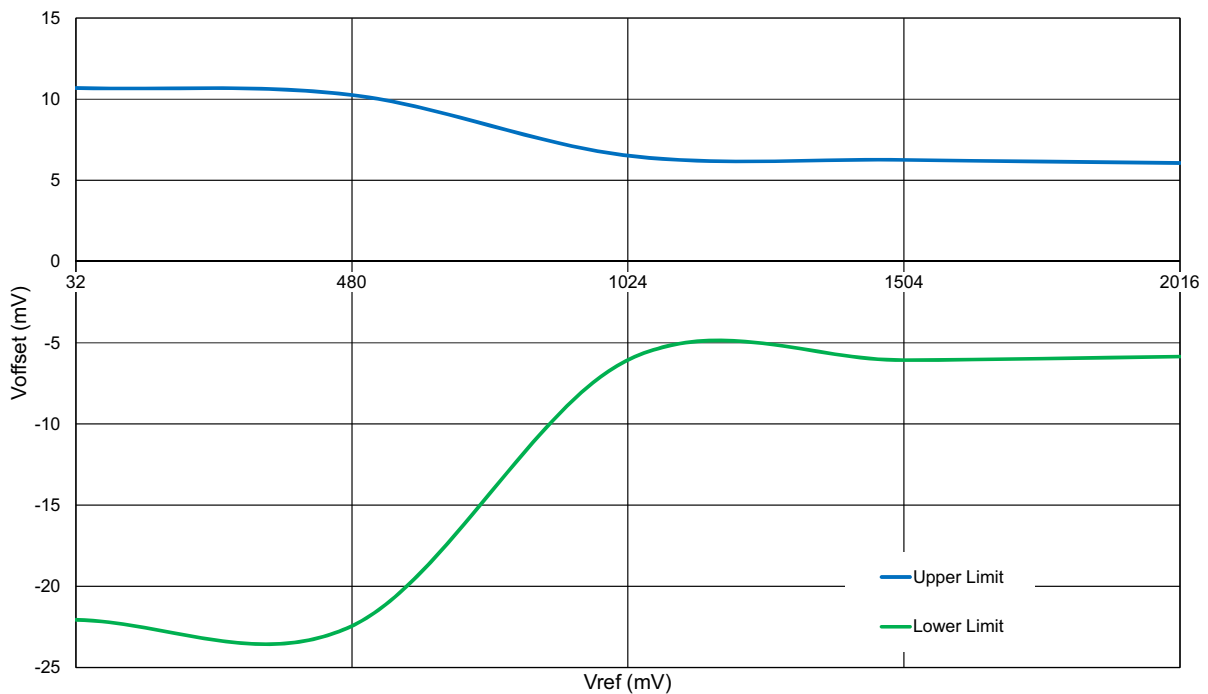

Figure 64: ACMPxH Input Offset Voltage vs. Vref at T = -40 °C to 105 °C, Input Buffer Enabled

SLG46827-A

Auto AEC-Q100 Qualified GreenPAK
Programmable Mixed-Signal Matrix with In-System Debug

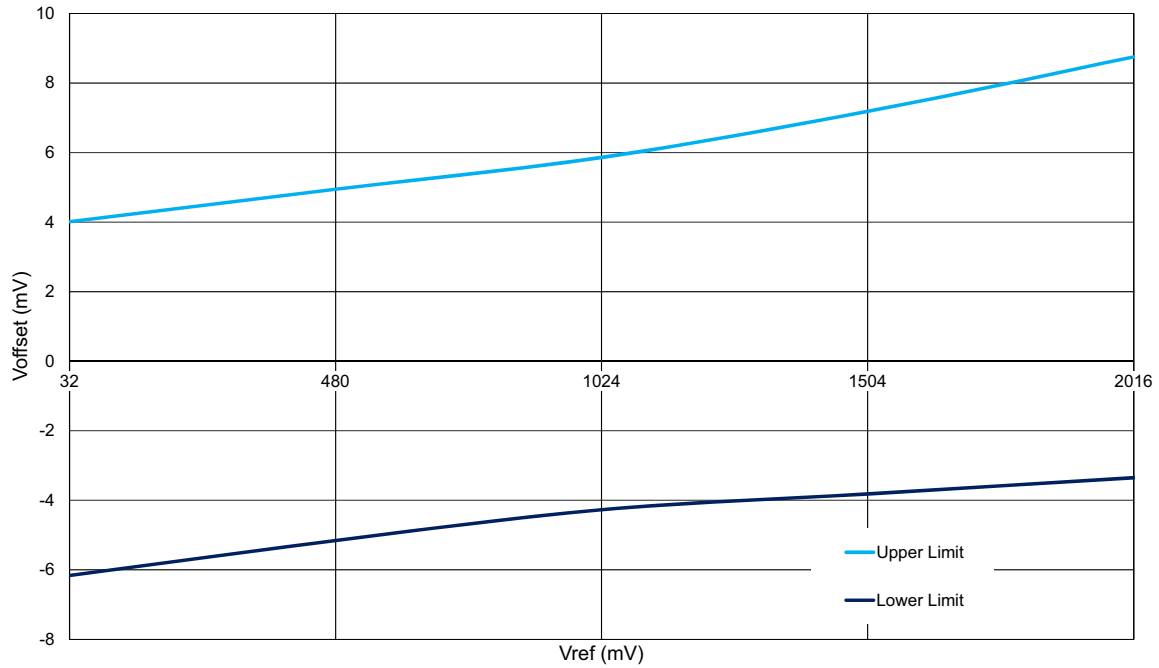

Figure 65: ACMPxL Input Offset Voltage vs. Vref at T = -40 °C to 105 °C

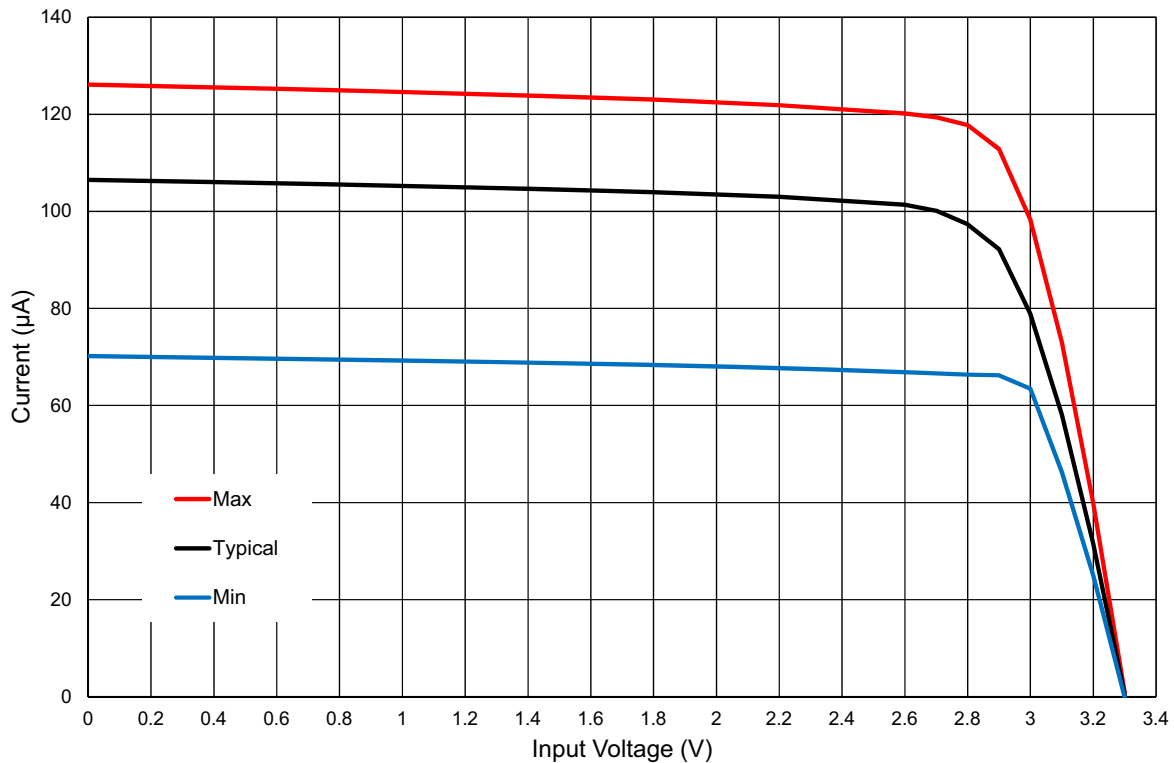

Figure 66: ACMP Input Current Source vs. Input Voltage at T = -40 °C to 105 °C, V_{DD} = 3.3 V

SLG46827-A

Auto AEC-Q100 Qualified GreenPAK
Programmable Mixed-Signal Matrix with In-System Debug

10 Programmable Delay/Edge Detector

The SLG46827-A has a programmable time delay logic cell available that can generate a delay that is selectable from one of four timings (time 2) configured in the GreenPAK Designer. The programmable time delay cell can generate one of four different delay patterns, rising edge detection, falling edge detection, both edge detection, and both edge delay. These four patterns can be further modified with the addition of delayed edge detection, which adds an extra unit of delay, as well as glitch rejection during the delay period. See Figure 68 for further information.

Note: The input signal must be longer than the delay, otherwise it will be filtered out.

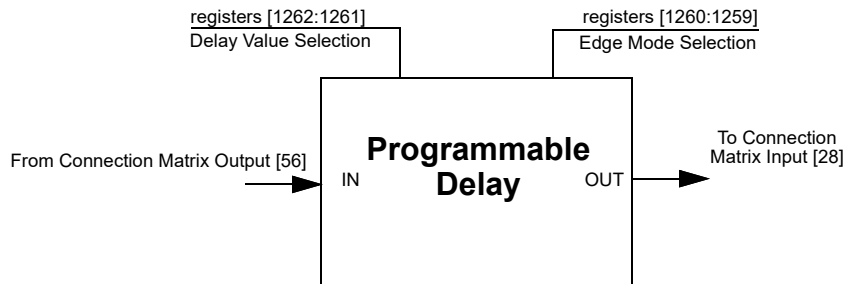

Figure 67: Programmable Delay

10.1 PROGRAMMABLE DELAY TIMING DIAGRAM - EDGE DETECTOR OUTPUT

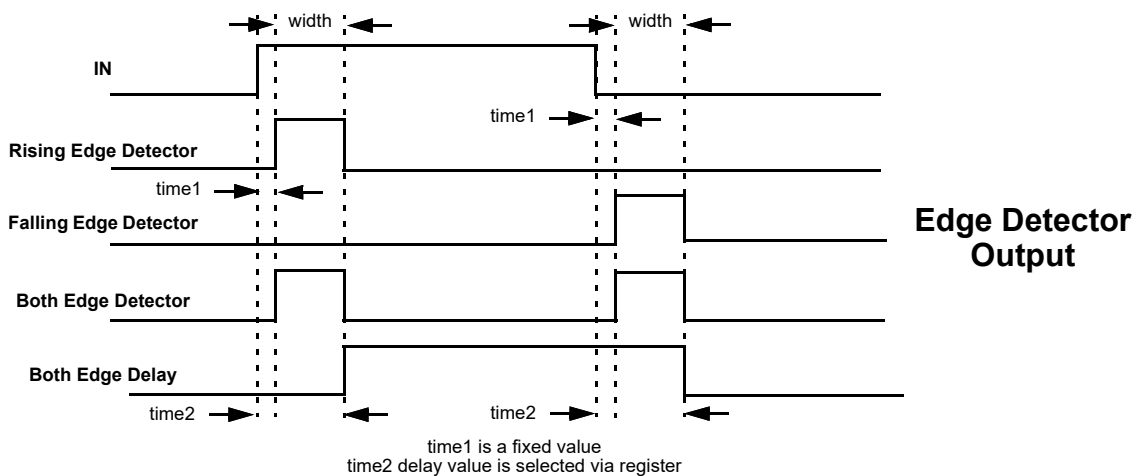

Figure 68: Edge Detector Output

Please refer to Table 12.

SLG46827-A

Auto AEC-Q100 Qualified GreenPAK
 Programmable Mixed-Signal Matrix with In-System Debug

11 Additional Logic Function. Deglitch Filter

The SLG46827-A has one Deglitch Filter macrocell with inverter function that is connected directly to the Connection Matrix inputs and outputs. In addition, this macrocell can be configured as an Edge Detector, with the following settings:

- Rising Edge Detector
- Falling Edge Detector
- Both Edge Detector
- Both Edge Delay

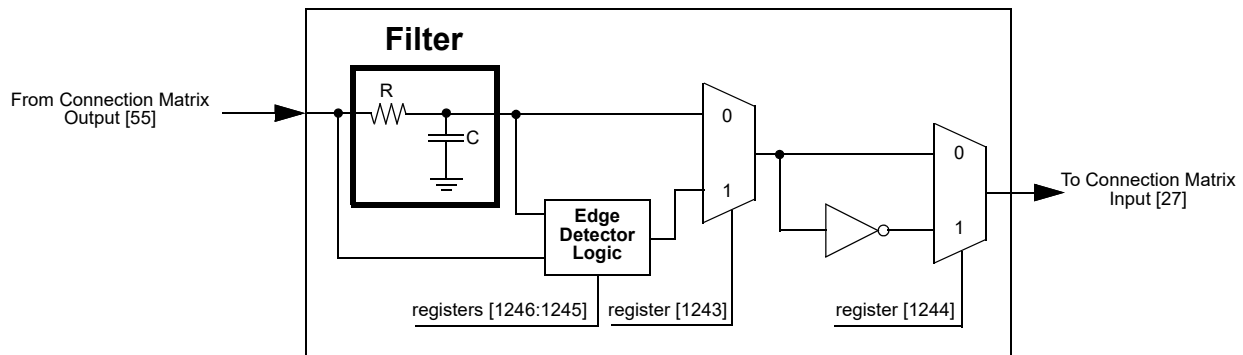

Figure 69: Deglitch Filter or Edge Detector

SLG46827-A

Auto AEC-Q100 Qualified GreenPAK Programmable Mixed-Signal Matrix with In-System Debug

12 Voltage Reference

12.1 VOLTAGE REFERENCE OVERVIEW

The SLG46827-A has a Voltage Reference (Vref) Macrocell to provide references to the four analog comparators. This macrocell can supply a user selection of fixed voltage references, or temperature sensor output. The macrocell also has the option to output reference voltages on IO9 and IO10. See [Table 48](#) for the available selections for each analog comparator. Also, see [Figure 70](#), which shows the reference output structure.

12.2 VREF SELECTION TABLE

Table 48: Vref Selection Table

SEL[5:0]	Vref	SEL[5:0]	Vref
0	0.032	32	1.056
1	0.064	33	1.088
2	0.096	34	1.12
3	0.128	35	1.152
4	0.16	36	1.184
5	0.192	37	1.216
6	0.224	38	1.248
7	0.256	39	1.28
8	0.288	40	1.312
9	0.32	41	1.344
10	0.352	42	1.376
11	0.384	43	1.408
12	0.416	44	1.44
13	0.448	45	1.472
14	0.48	46	1.504
15	0.512	47	1.536
16	0.544	48	1.568
17	0.576	49	1.6
18	0.608	50	1.632
19	0.64	51	1.664
20	0.672	52	1.696
21	0.704	53	1.728
22	0.736	54	1.76
23	0.768	55	1.792
24	0.8	56	1.824
25	0.832	57	1.856
26	0.864	58	1.888
27	0.896	59	1.92
28	0.928	60	1.952
29	0.96	61	1.984
30	0.992	62	2.016
31	1.024	63	External

SLG46827-A

Auto AEC-Q100 Qualified GreenPAK
Programmable Mixed-Signal Matrix with In-System Debug

12.3 VREF BLOCK DIAGRAM

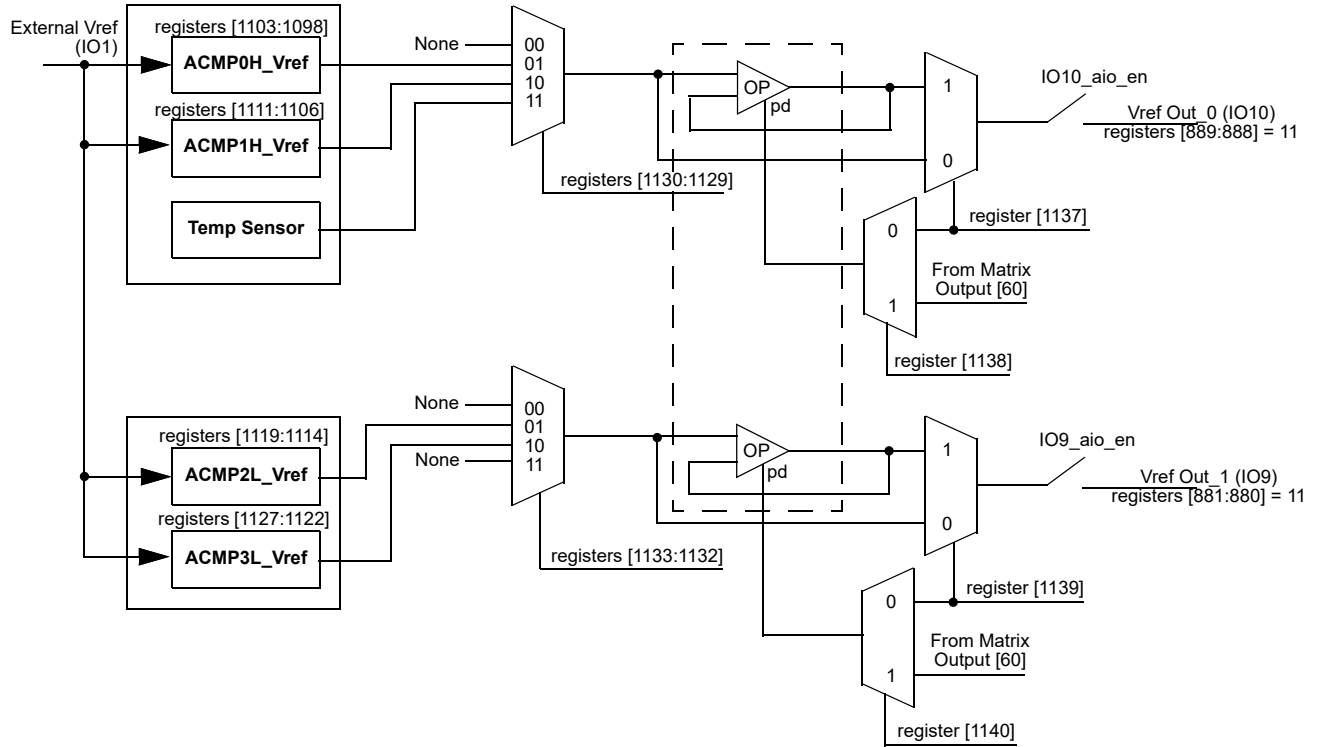

Figure 70: Voltage Reference Block Diagram

SLG46827-A

Auto AEC-Q100 Qualified GreenPAK
Programmable Mixed-Signal Matrix with In-System Debug

12.4 VREF LOAD REGULATION

Note 1 It is not recommended to use Vref connected to external pin without buffer.

Note 2 Vref buffer performance is not guaranteed at $V_{DD} < 2.7$ V.

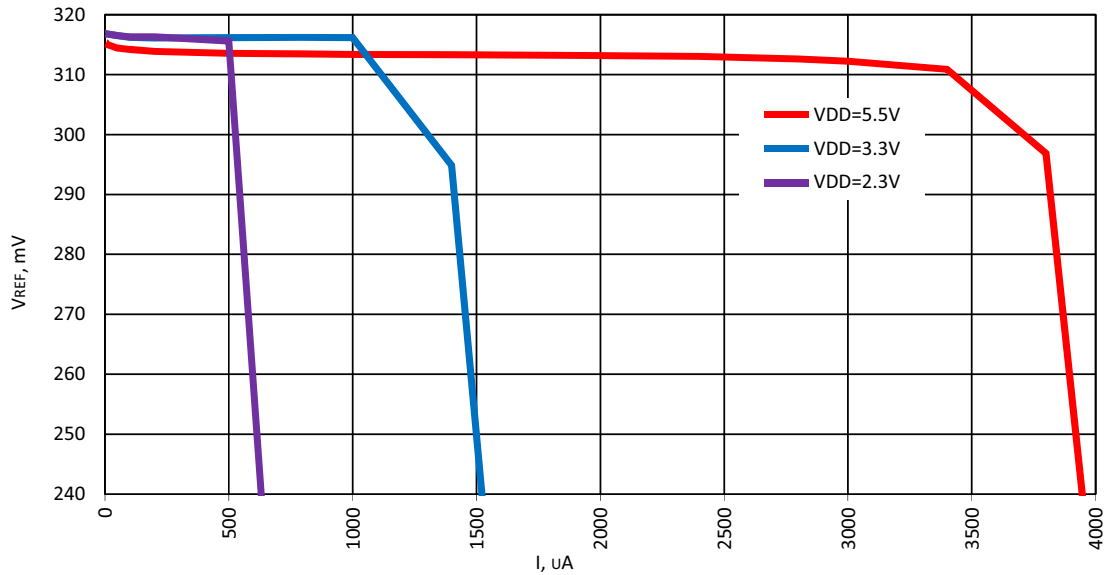

Figure 71: Typical Load Regulation, Vref = 320 mV, T = -40 °C to +105 °C, Buffer - Enable

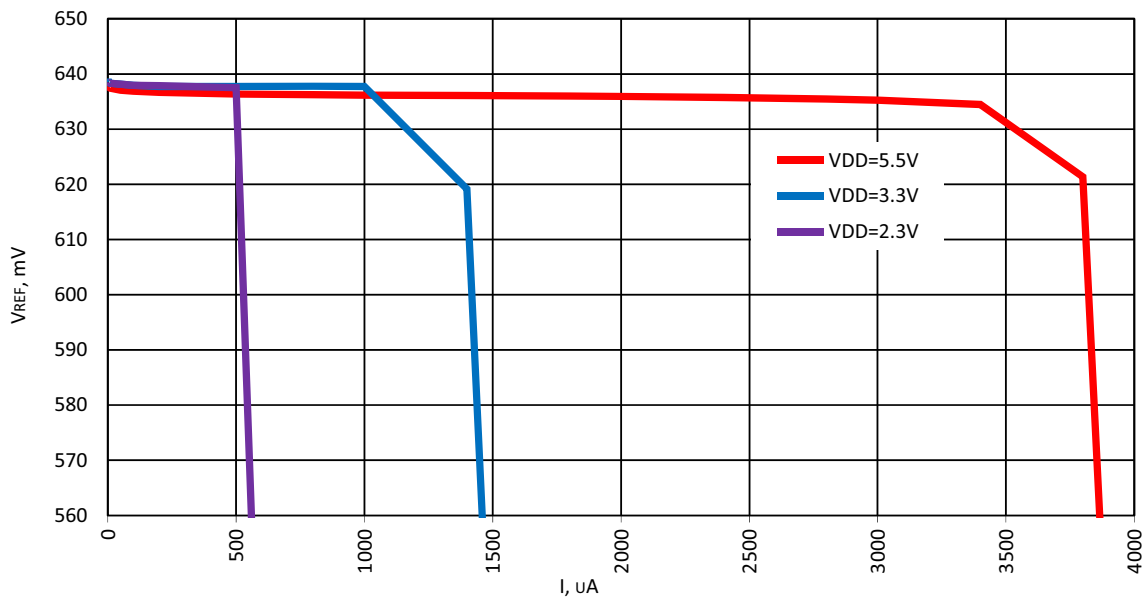

Figure 72: Typical Load Regulation, Vref = 640 mV, T = -40 °C to +105 °C, Buffer - Enable

SLG46827-A

Auto AEC-Q100 Qualified GreenPAK
Programmable Mixed-Signal Matrix with In-System Debug

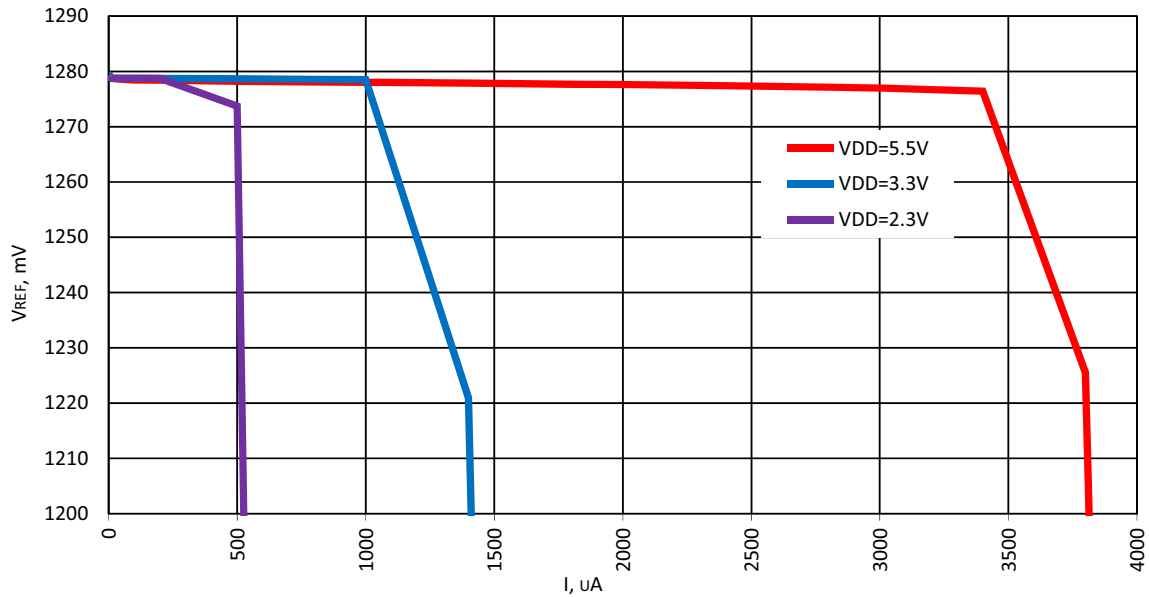

Figure 73: Typical Load Regulation, Vref = 1280 mV, T = -40 °C to +105 °C, Buffer - Enable

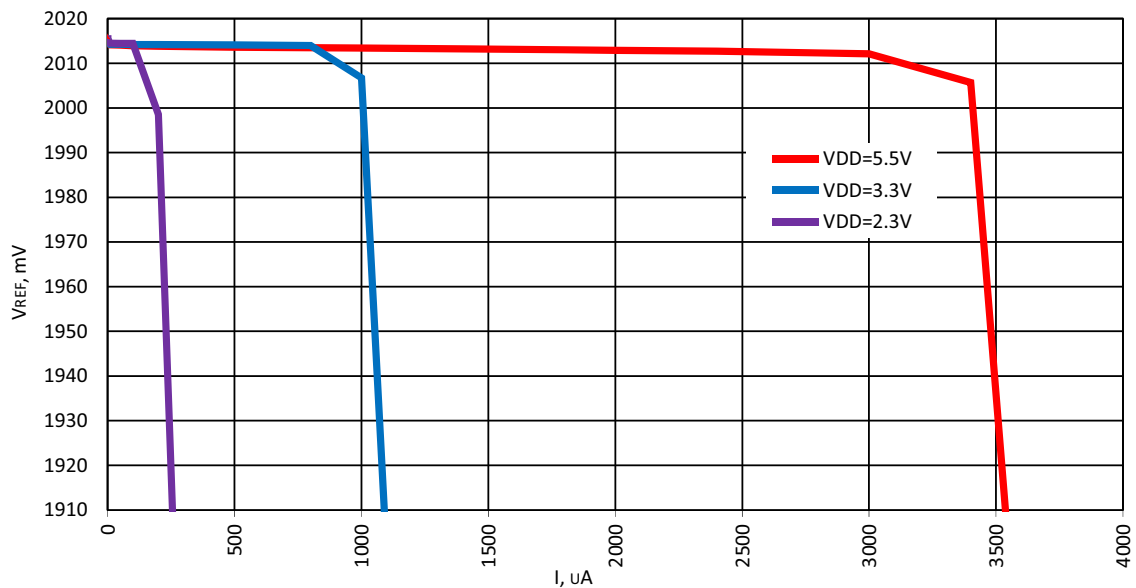

Figure 74: Typical Load Regulation, Vref = 2016 mV, T = -40 °C to +105 °C, Buffer - Enable

SLG46827-A

Auto AEC-Q100 Qualified GreenPAK Programmable Mixed-Signal Matrix with In-System Debug

13 Clocking

13.1 OSCILLATOR GENERAL DESCRIPTION

The SLG46827-A has three internal oscillators to support a variety of applications:

- Oscillator0 (2.048 kHz)
- Oscillator1 (2.048 MHz)
- Oscillator2 (25 MHz)

There are two divider stages for each oscillator that gives the user flexibility for introducing clock signals to connection matrix, as well as various other Macrocells. The pre-divider (first stage) for Oscillator allows the selection of /1, /2, /4 or /8 to divide down frequency from the fundamental. The second stage divider has an input of frequency from the pre-divider, and outputs one of eight different frequencies divided by /1, /2, /3, /4, /8, /12, /24 or /64 on Connection Matrix Input lines [27], [28], and [29]. Please see [Figure 78](#) for more details on the SLG46827-A clock scheme.

Oscillator2 (25 MHz) has an additional function of 100 ns delayed startup, which can be enabled/disabled by register [1052]. This function is recommended to use when analog blocks are used along with the Oscillator.

The Matrix Power-down/Force On function allows switching off or force on the oscillator using an external pin. The Matrix Power-down/Force On (Connection Matrix Output [72], [73], [74]) signal has the highest priority. The OSC operates according to the [Table 49](#).

Table 49: Oscillator Operation Mode Configuration Settings

POR	External Clock Selection	Signal From Connection Matrix	Register: Power-Down or Force On by Matrix Input	Register: Auto Power-On or Force On	OSC Enable Signal from CNT/DLY Macrocells	OSC Operation Mode
0	X	X	X	X	X	OFF
1	1	X	X	X	X	Internal OSC is OFF, logic is ON
1	0	1	0	X	X	OFF
1	0	1	1	X	X	ON
1	0	0	X	1	X	ON
1	0	0	X	0	CNT/DLY requires OSC	ON
1	0	0	X	0	CNT/DLY does not require OSC	OFF

Note 1 The OSC will run only when any macrocell that uses OSC is powered on.

SLG46827-A

Auto AEC-Q100 Qualified GreenPAK
Programmable Mixed-Signal Matrix with In-System Debug

13.2 OSCILLATOR0 (2.048 KHZ)

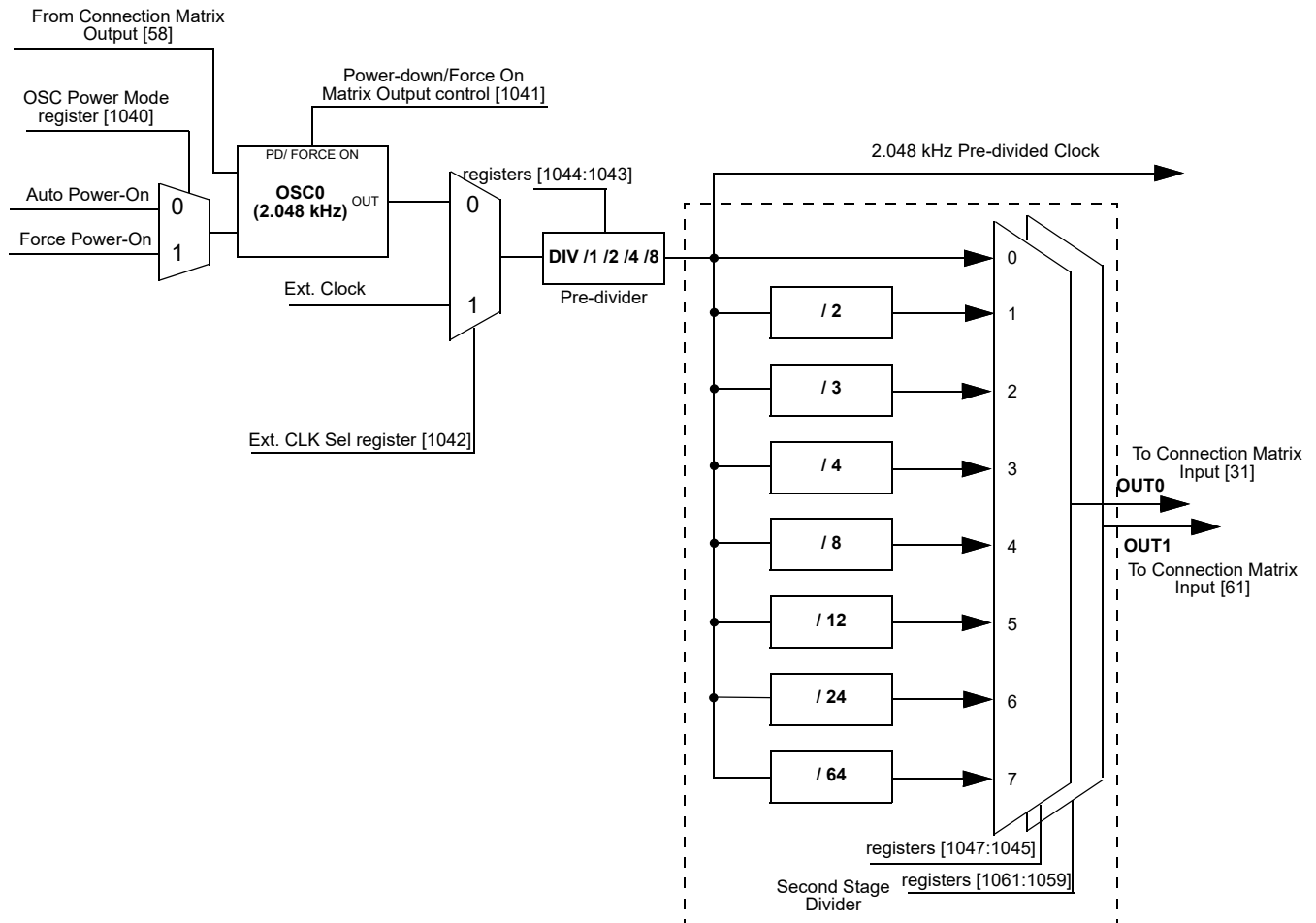

Figure 75: Oscillator0 Block Diagram

SLG46827-A

Auto AEC-Q100 Qualified GreenPAK
Programmable Mixed-Signal Matrix with In-System Debug

13.3 OSCILLATOR1 (2.048 MHZ)

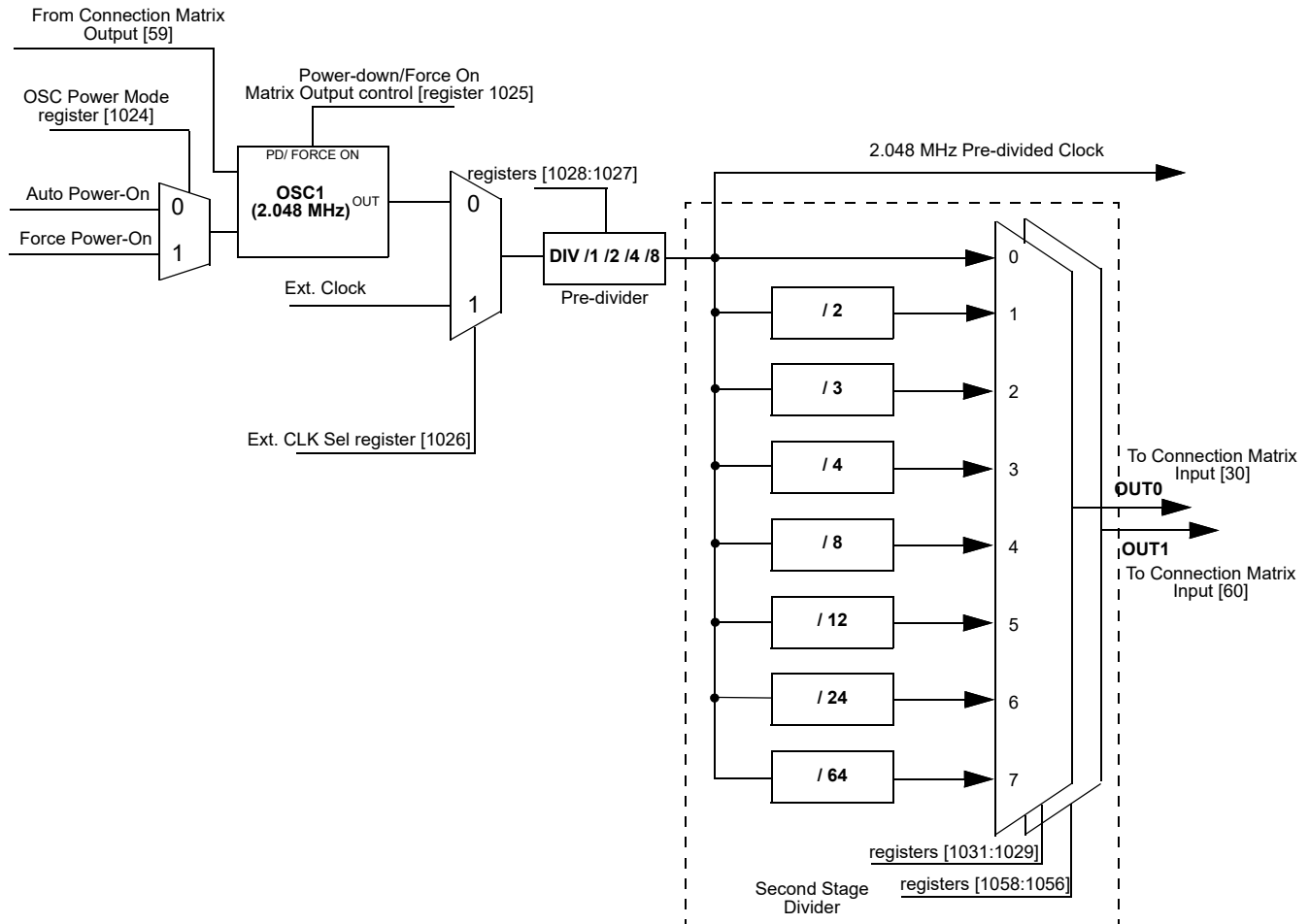

Figure 76: Oscillator1 Block Diagram

SLG46827-A

Auto AEC-Q100 Qualified GreenPAK
Programmable Mixed-Signal Matrix with In-System Debug

13.4 OSCILLATOR2 (25 MHZ)

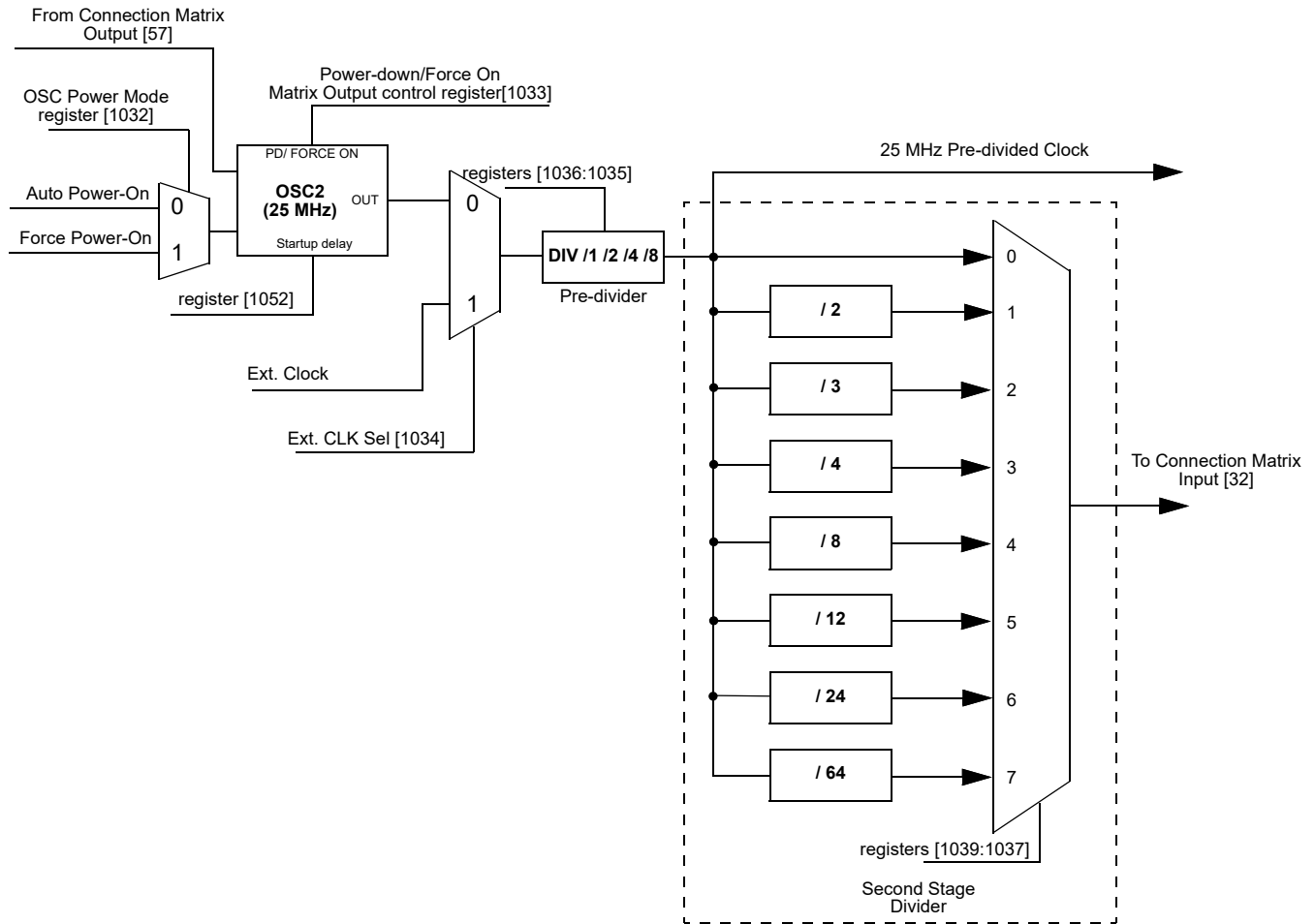

Figure 77: Oscillator2 Block Diagram

SLG46827-A

Auto AEC-Q100 Qualified GreenPAK Programmable Mixed-Signal Matrix with In-System Debug

13.5 CNT/DLY CLOCK SCHEME

Each CNT/DLY within Multi-Function macrocell has its own additional clock divider connected to oscillators pre-divider. Available dividers are:

- OSC0/1, OSC0/8, OSC0/64, OSC0/512, OSC0/4096, OSC0/32768, OSC0/262144
- OSC1/1, OSC1/8, OSC1/64, OSC1/512
- OSC2/1, OSC2/4

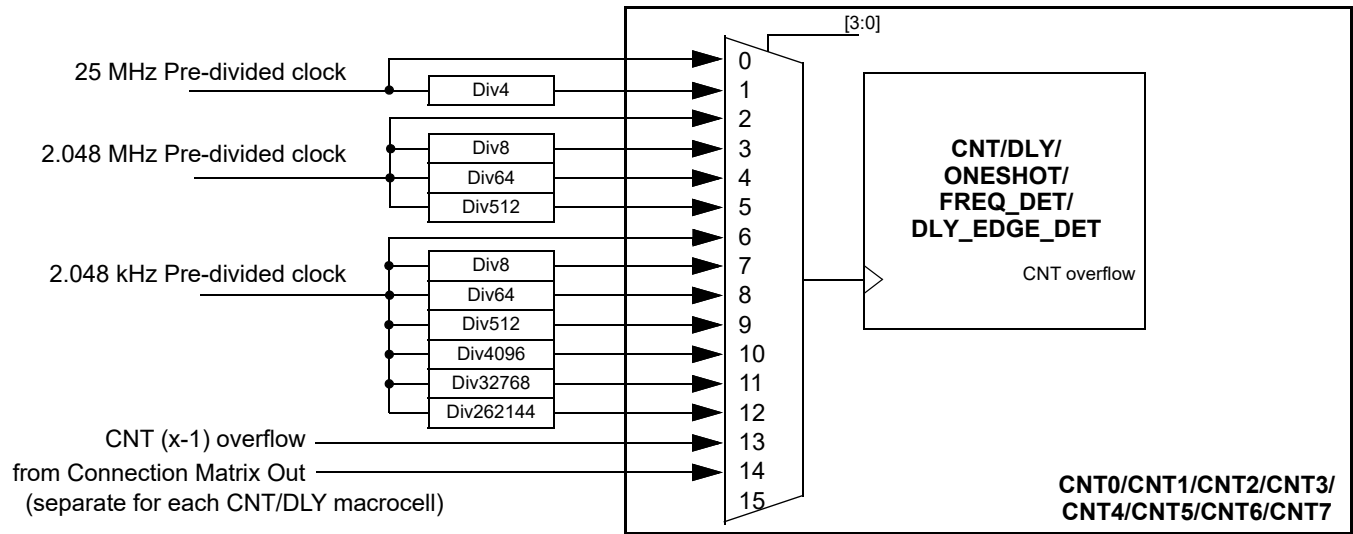

Figure 78: Clock Scheme

13.6 EXTERNAL CLOCKING

The SLG46827-A supports several ways to use an external, higher accuracy clock as a reference source for internal operations.

13.6.1 IO0 Source for Oscillator0 (2.048 kHz)

When register [1042] is set to 1, an external clocking signal on IO0 will be routed in place of the internal oscillator derived 2.048 kHz clock source. See Figure 75. The high and low limits for frequency that can be selected are 0 MHz and 10 MHz.

13.6.2 IO10 Source for Oscillator1 (2.048 MHz)

When register [1026] is set to 1, an external clocking signal on IO10 will be routed in place of the internal oscillator derived 2.048 MHz clock source. See Figure 76. The high and low limits for frequency that can be selected are 0 MHz and 10 MHz.

13.6.3 IO8 Source for Oscillator2 (25 MHz)

When register [1034] is set to 1, an external clocking signal on IO8 will be routed in place of the internal oscillator derived 25 MHz clock source. See Figure 77. The external frequency range is 0 MHz to 20 MHz at $V_{DD} = 2.3$ V, 0 MHz to 30 MHz at $V_{DD} = 3.3$ V, 0 MHz to 50 MHz at $V_{DD} = 5.0$ V. When an external clock is selected for OSC2, the oscillator's output signal will be inverted with respect to the IO8 input signal.

SLG46827-A

Auto AEC-Q100 Qualified GreenPAK
Programmable Mixed-Signal Matrix with In-System Debug

13.7 OSCILLATORS POWER-ON DELAY

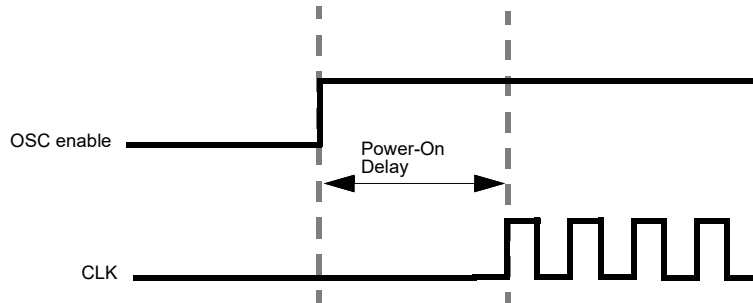

Figure 79: Oscillator Startup Diagram

Note 1 OSC power mode: “Auto Power-On”.

Note 2 “OSC enable” signal appears when any macrocell that uses OSC is powered on.

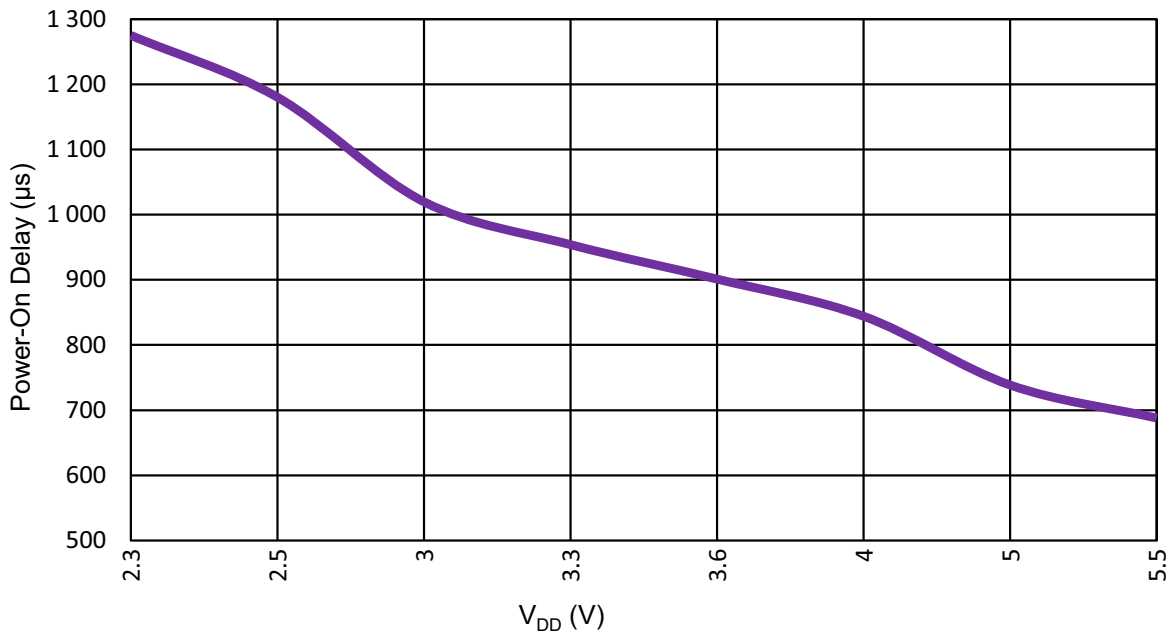

Figure 80: Oscillator0 Maximum Power-On Delay vs. V_{DD} at T = 25 °C, OSC0 = 2.048 kHz

SLG46827-A

Auto AEC-Q100 Qualified GreenPAK
 Programmable Mixed-Signal Matrix with In-System Debug

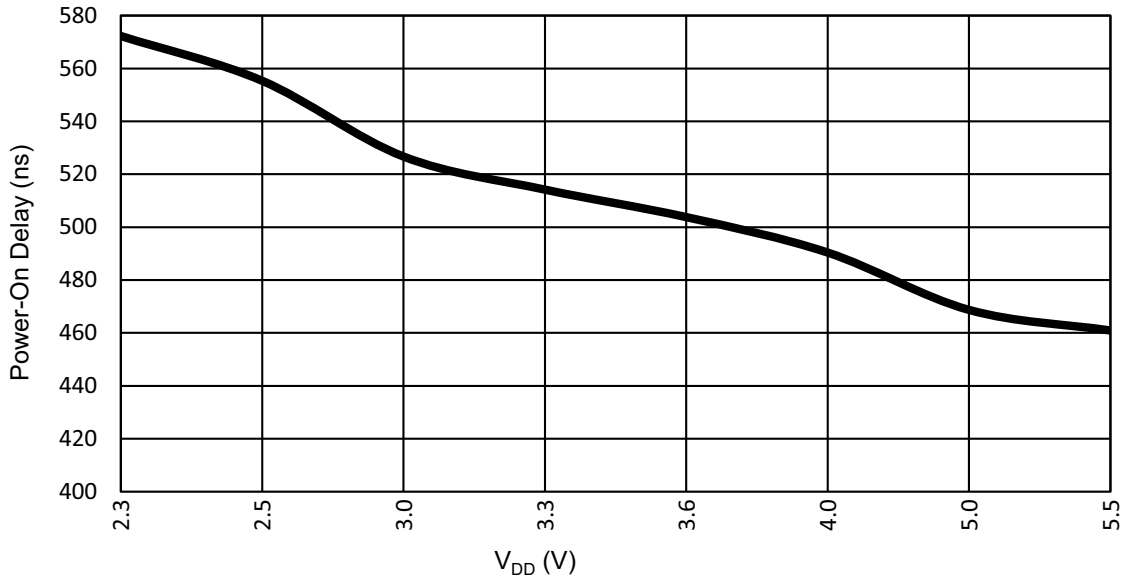

Figure 81: Oscillator1 Maximum Power-On Delay vs. V_{DD} at T = 25 °C, OSC1 = 2.048 MHz

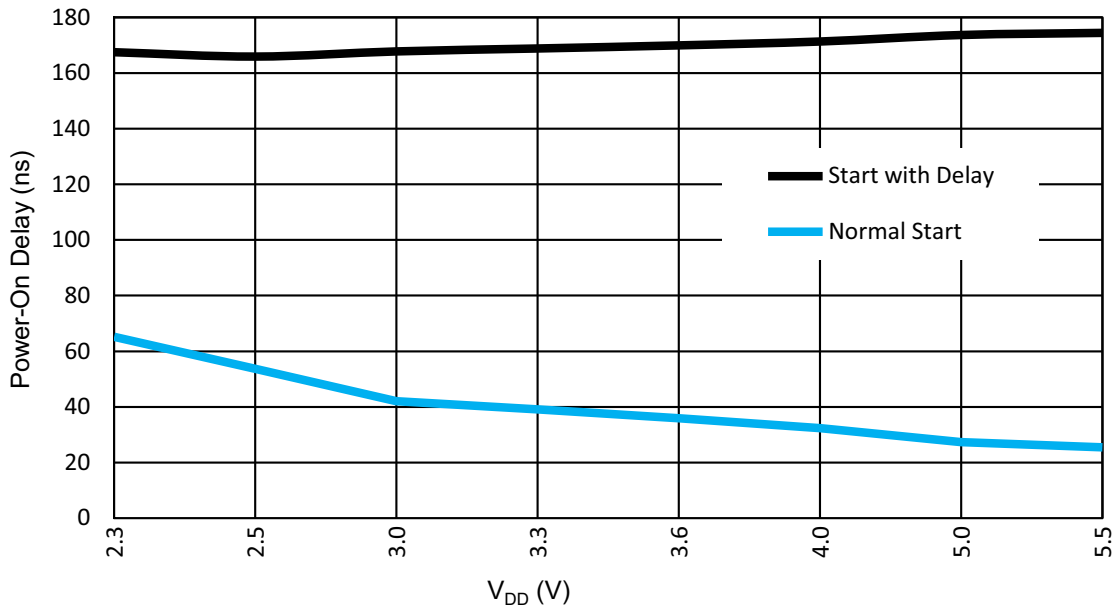

Figure 82: Oscillator2 Maximum Power-On Delay vs. V_{DD} at T = 25 °C, OSC2 = 25 MHz

SLG46827-A

Auto AEC-Q100 Qualified GreenPAK
Programmable Mixed-Signal Matrix with In-System Debug

13.8 OSCILLATORS ACCURACY

Note: OSC power setting: Force Power-On; Clock to matrix input - enable; Bandgap: turn on by register - enable.

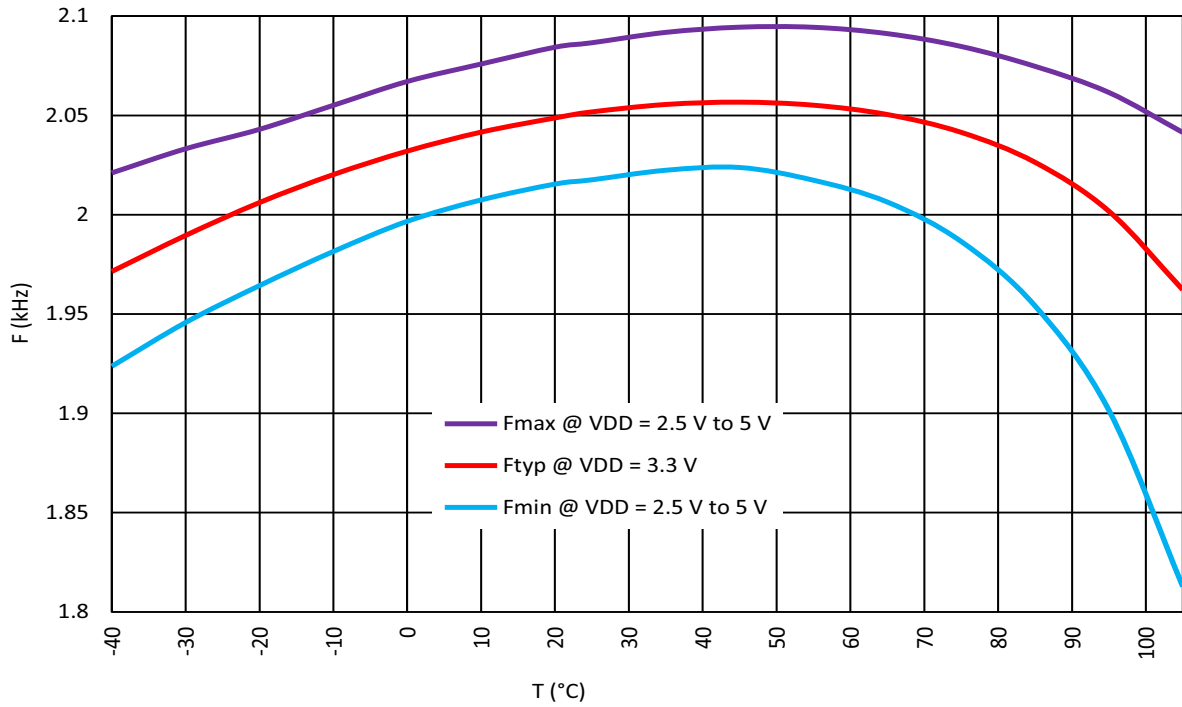

Figure 83: Oscillator0 Frequency vs. Temperature, OSC0 = 2.048 kHz

SLG46827-A

Auto AEC-Q100 Qualified GreenPAK
Programmable Mixed-Signal Matrix with In-System Debug

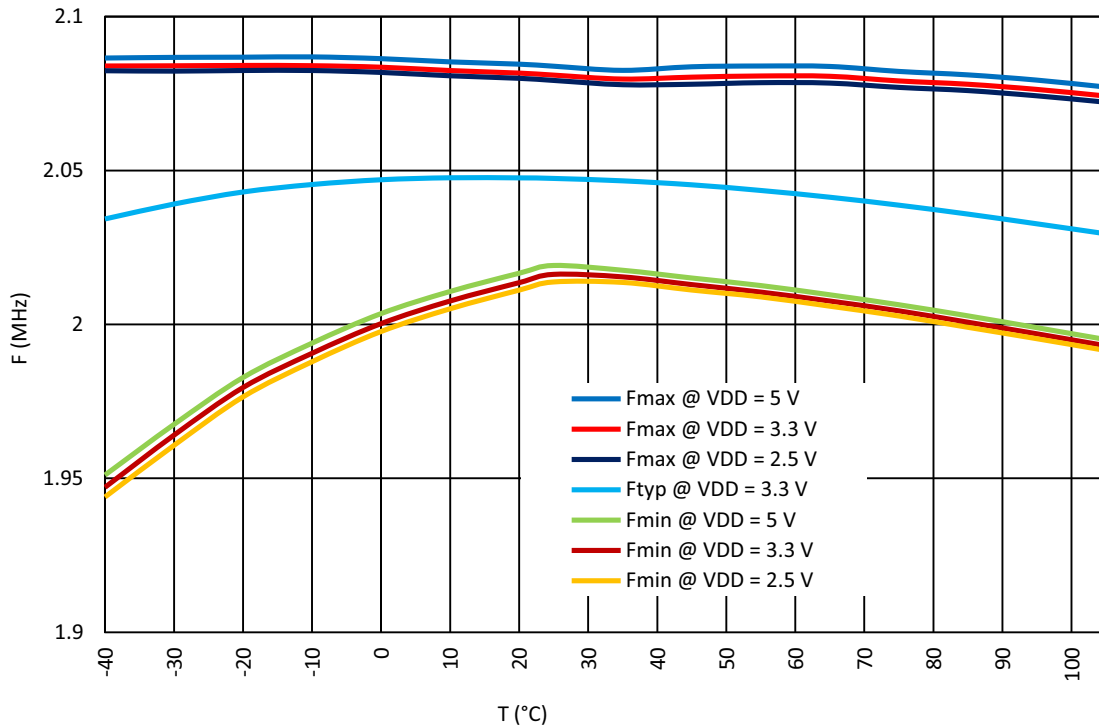

Figure 84: Oscillator1 Frequency vs. Temperature, OSC1 = 2.048 MHz

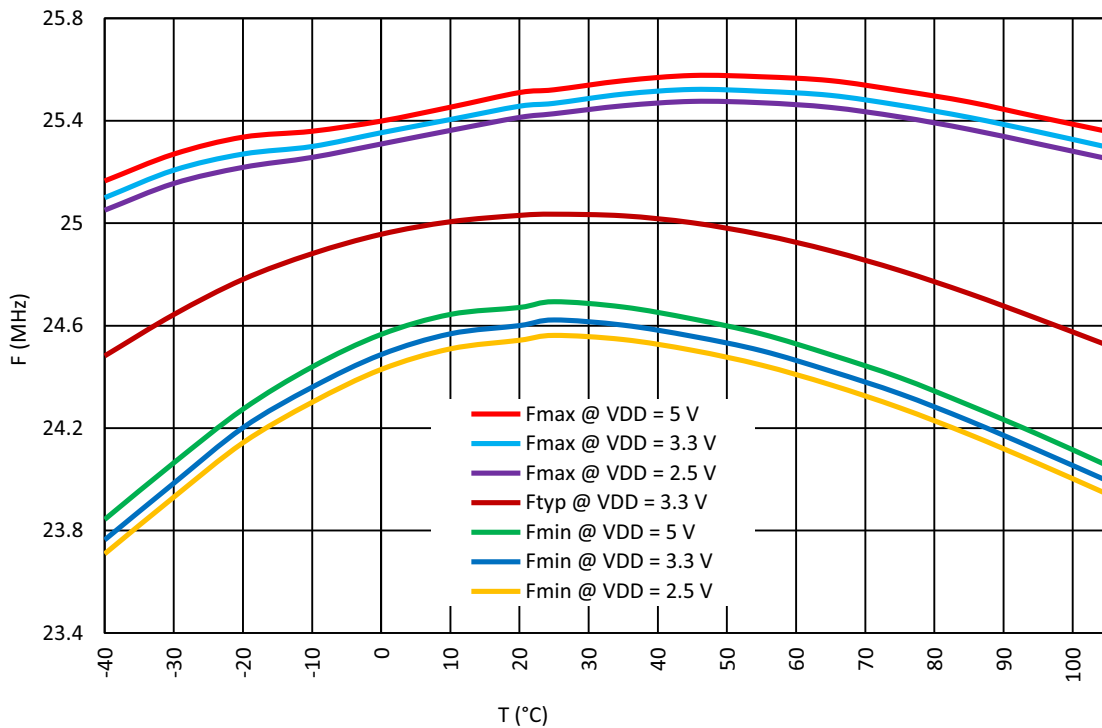

Figure 85: Oscillator2 Frequency vs. Temperature, OSC2 = 25 MHz

Note: For more information see Section 3.6.

SLG46827-A

Auto AEC-Q100 Qualified GreenPAK
Programmable Mixed-Signal Matrix with In-System Debug

Table 50: Oscillator Output Duty Cycle

Pre-divider	Second Stage Divider									
	OSC0 OSC1	OSC2	OSC0 OSC1 OSC2	OSC0 OSC1	OSC2	OSC0 OSC1 OSC2	OSC0 OSC1 OSC2	OSC0 OSC1 OSC2	OSC0 OSC1 OSC2	OSC0 OSC1 OSC2
	1		2	3		4	8	12	24	64
1	50	60	50	33.3	66	50	50	50	50	50
2	50	50	50	33.3	66	50	50	50	50	50
4	50	50	50	33.3	66	50	50	50	50	50
8	50	50	50	33.3	66	50	50	50	50	50

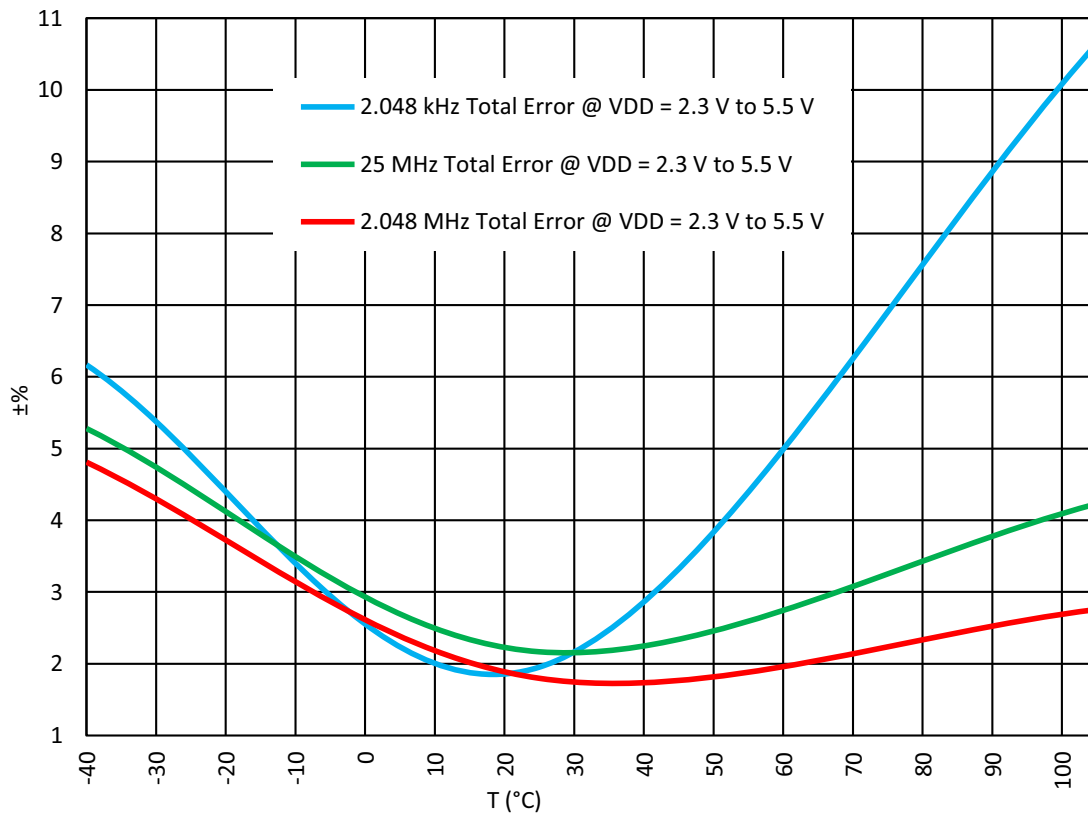

Figure 86: Oscillators Total Error vs. Temperature

SLG46827-A

Auto AEC-Q100 Qualified GreenPAK Programmable Mixed-Signal Matrix with In-System Debug

14 Power-On Reset

The SLG46827-A has a Power-On Reset (POR) macrocell to ensure correct device initialization and operation of all macrocells in the device. The purpose of the POR circuit is to have consistent behavior and predictable results when the V_{DD} power is first ramping to the device, and also while the V_{DD} is falling during power-down. To accomplish this goal, the POR drives a defined sequence of internal events that trigger changes to the states of different macrocells inside the device, and finally to the state of the IOs.

14.1 GENERAL OPERATION

The SLG46827-A is guaranteed to be powered down and non-operational when the V_{DD} voltage (voltage on PIN20 for TSSOP package) is less than Power-Off Threshold (see in [Table 3.4](#)), but not less than -0.6 V. Another essential condition for the chip to be powered down is that no voltage higher (Note) than the V_{DD} voltage is applied to any other PIN. For example, if V_{DD} voltage is 0.3 V, applying a voltage higher than 0.3 V to any other PIN is incorrect, and can lead to incorrect or unexpected device behavior.

Note: There is a 0.6 V margin due to forward drop voltage of the ESD protection diodes.

To start the POR sequence in the SLG46827-A, the voltage applied on the V_{DD} should be higher than the Power-On threshold (Note). The full operational V_{DD} range for the SLG46827-A is 2.3 V to 5.5 V. This means that the V_{DD} voltage must ramp up to the operational voltage value, but the POR sequence will start earlier, as soon as the V_{DD} voltage rises to the Power-On threshold. After the POR sequence has started, the SLG46827-A will have a typical Startup Time (see in [Table 3.4](#)) to go through all the steps in the sequence, and will be ready and completely operational after the POR sequence is complete.

Note: The Power-On threshold is defined in [Table 3.4](#).

To power down the chip, the V_{DD} voltage should be lower than the operational and to guarantee that chip is powered down, it should be less than Power-Off Threshold.

All PINs are in high impedance state when the chip is powered down and while the POR sequence is taking place. The last step in the POR sequence releases the IO structures from the high impedance state, at which time the device is operational. The pin configuration at this point in time is defined by the design programmed into the chip. Also, as it was mentioned before, the voltage on PINs can't be bigger than the V_{DD} , this rule also applies to the case when the chip is powered on.

SLG46827-A

Auto AEC-Q100 Qualified GreenPAK Programmable Mixed-Signal Matrix with In-System Debug

14.2 POR SEQUENCE

The POR system generates a sequence of signals that enable certain macrocells. The sequence is shown in [Figure 87](#).

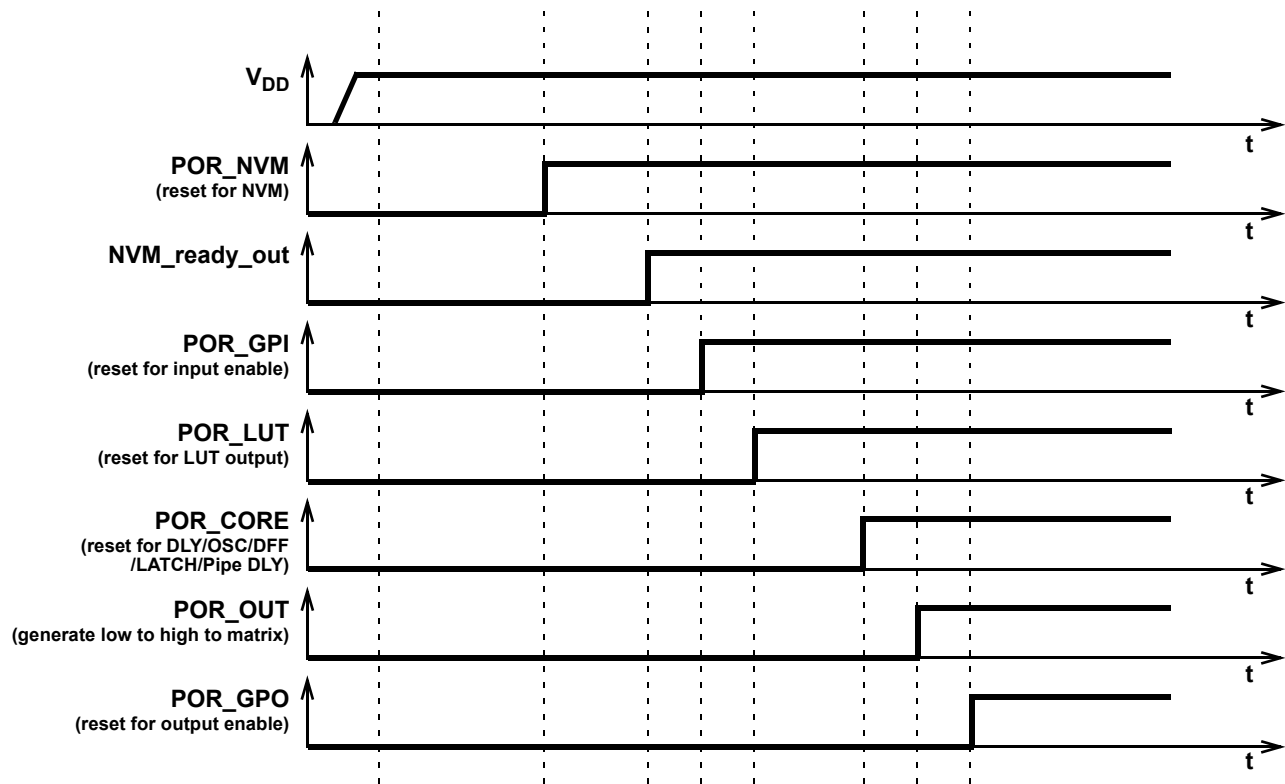

Figure 87: POR Sequence

As can be seen from [Figure 87](#) after the V_{DD} has started ramping up and crossed the Power-On threshold, first, the on-chip NVM memory is reset. Next, the chip reads the data from NVM, and transfers this information to a CMOS LATCH that serves to configure each macrocell, and the Connection Matrix which routes signals between macrocells. The third stage causes the reset of the input pins, and then to enable them. After that, the LUTs are reset and become active. After LUTs, the Delay cells, OSCs DFFs, LATCHES, and Pipe Delay are initialized. Only after all macrocells are initialized, internal POR signal (POR macrocell output) goes from LOW to HIGH (POR_OUT in [Figure 87](#)). The last portion of the device to be initialized is the output pins, which transition from high impedance to active at this point.

The typical time that takes to complete the POR sequence varies by device type in the GreenPAK family. It also depends on many environmental factors, such as: slew rate, V_{DD} value, temperature, and even will vary from chip to chip (process influence).

14.3 MACROCELLS OUTPUT STATES DURING POR SEQUENCE

To have a full picture of SLG46827-A operation during powering and POR sequence, refer to [Figure 88](#) which describes the macrocell output states during the POR sequence.

First, before the NVM has been reset, all macrocells have their output set to logic LOW (except the output pins which are in high impedance state). On the next step, some of the macrocells start initialization: input pins output state becomes LOW; LUTs also output LOW. After that input pins are enabled. Next, only LUTs are configured. Then, all other macrocells are initialized. After macrocells are initialized, internal POR matrix signal switches from LOW to HIGH. The last are output pins that become active and determined by the input signals.

SLG46827-A

Auto AEC-Q100 Qualified GreenPAK Programmable Mixed-Signal Matrix with In-System Debug

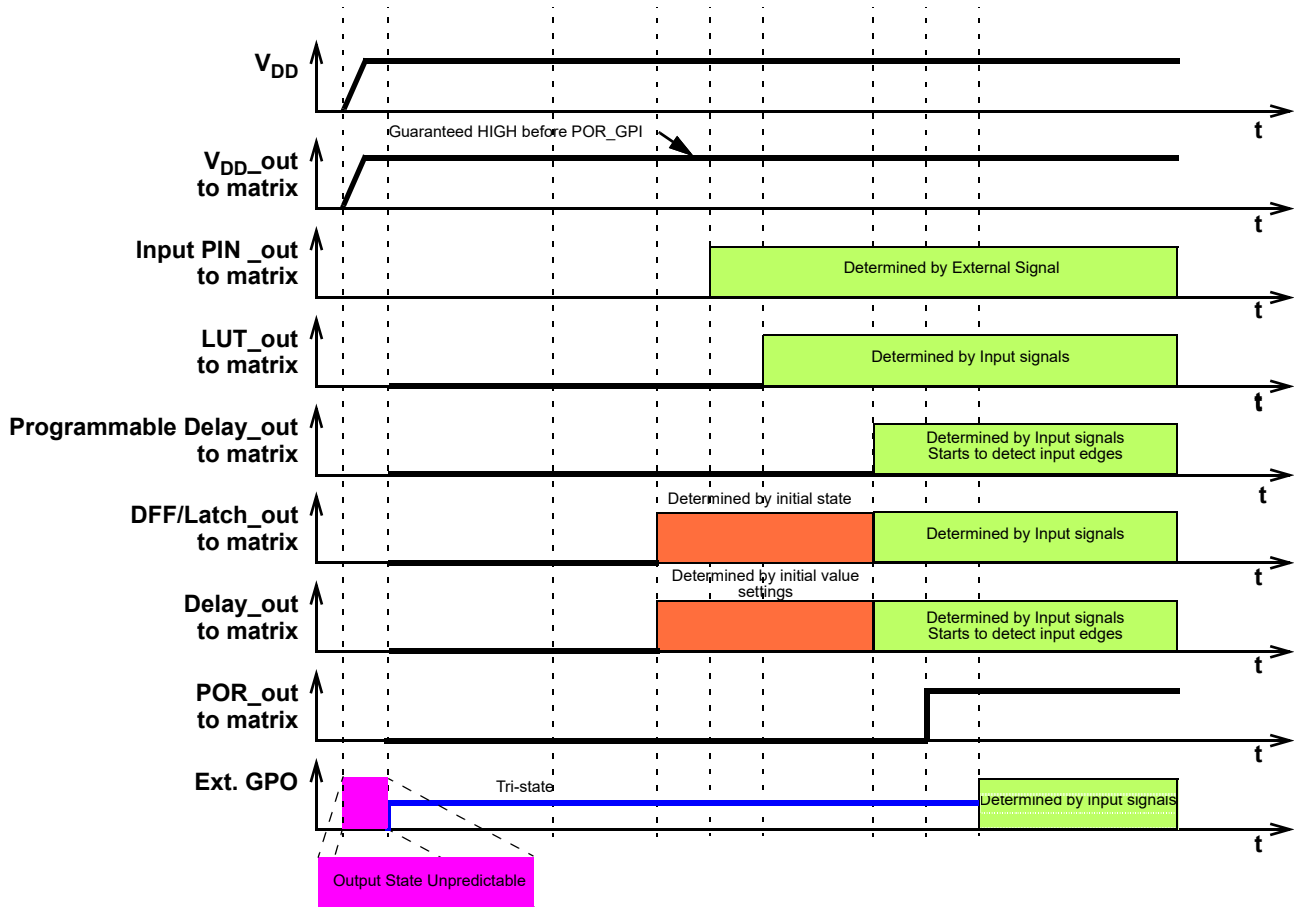

Figure 88: Internal Macrocell States during POR Sequence

14.3.1 Initialization

All internal macrocells by default have initial low level. Starting from indicated power-up time of 1.52 V to 2.12 V, macrocells in SLG46827-A are powered on while forced to the reset state. All outputs are in Hi-Z and chip starts loading data from NVM. Then the reset signal is released for internal macrocells and they start to initialize according to the following sequence:

1. Input pins, Pull-up/down.
2. LUTs.
3. DFFs, Delays/Counters, Pipe Delay, OSCs, ACMPs.
4. POR output to matrix.
5. Output pin corresponds to the internal logic.

The Vref output pin driving signal can precede POR output signal going high by 3 μs to 5 μs. The POR signal going high indicates the mentioned power-up sequence is complete.

Note: The maximum voltage applied to any pin should not be higher than the V_{DD} level. There are ESD Diodes between pin → V_{DD} and pin → GND on each pin. Exceeding V_{DD} results in leakage current on the input pin, and V_{DD} will be pulled up, following the voltage on the input pin.

SLG46827-A

Auto AEC-Q100 Qualified GreenPAK
 Programmable Mixed-Signal Matrix with In-System Debug

14.3.2 Power-Down

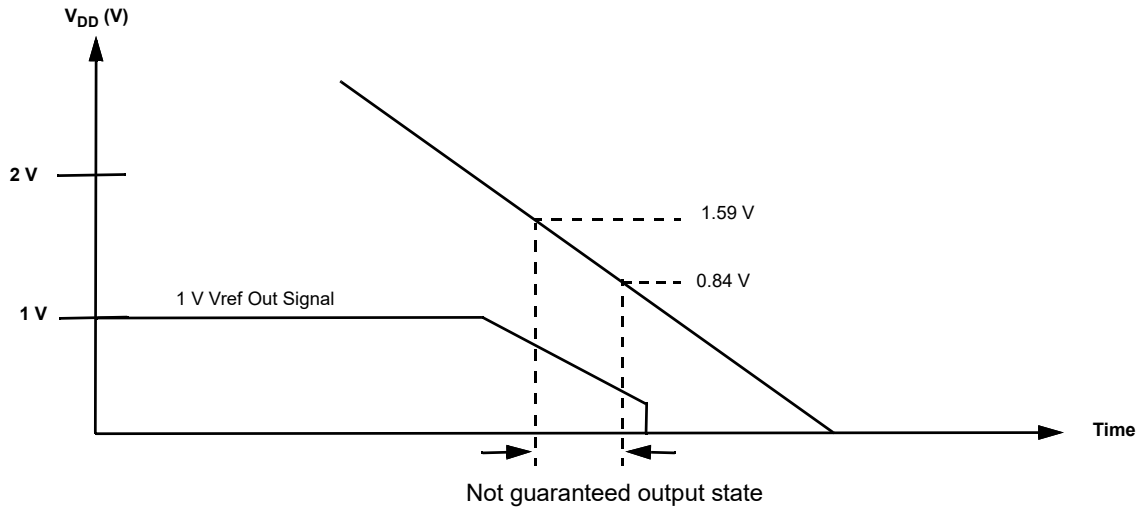

Figure 89: Power-Down

During power-down, macrocells in SLG46827-A are powered off after V_{DD} falling down below Power-Off Threshold. Please note that during a slow rampdown, outputs can possibly switch state.

SLG46827-A

Auto AEC-Q100 Qualified GreenPAK
Programmable Mixed-Signal Matrix with In-System Debug

15 I²C Serial Communications Macrocell

15.1 I²C SERIAL COMMUNICATIONS MACROCELL OVERVIEW

In the standard use case for the GreenPAK devices, the configuration choices made by the user are stored as bit settings in the Non-Volatile Memory (NVM), and this information is transferred at startup time to volatile RAM registers that enable the configuration of the macrocells. Other RAM registers in the device are responsible for setting the connections in the Connection Matrix to route signals in the manner most appropriate for the user’s application.

The I²C Serial Communications Macrocell in this device allows an I²C bus Master to read and write this information via a serial channel directly to the RAM registers, allowing the remote re-configuration of macrocells, and remote changes to signal chains within the device.

An I²C bus Master is also able read and write other register bits that are not associated with NVM memory. As an example, the input lines to the Connection Matrix can be read as digital register bits. These are the signal outputs of each of the macrocells in the device, giving an I²C bus Master the capability to remotely read the current value of any macrocell.

The user has the flexibility to control read access and write access via registers bits registers [1795:1792]. See Section 16 for more details on I²C read/write memory protection.

15.2 I²C SERIAL COMMUNICATIONS DEVICE ADDRESSING

Each command to the I²C Serial Communications macrocell begins with a Control Byte. The bits inside this Control Byte are shown in Figure 90. After the Start bit, the first four bits are a control code. Each bit in a control code can be sourced independently from the register or by value defined externally by IO5, IO4, IO3, and IO2. The LSB of the control code is defined by the value of IO2, while the MSB is defined by the value of IO5. The address source (either register bit or PIN) for each bit in the control code is defined by registers [1623:1620]. This gives the user flexibility on the chip level addressing of this device and other devices on the same I²C bus. The default control code is 0001. The Block Address is the next three bits (A10, A9, A8), which will define the most significant bits in the addressing of the data to be read or written by the command. The last bit in the Control Byte is the R/W bit, which selects whether a read command or write command is requested, with a “1” selecting for a Read command, and a “0” selecting for a Write command. This Control Byte will be followed by an Acknowledge bit (ACK), which is sent by this device to indicate successful communication of the Control Byte data.

In the I²C-bus specification and user manual, there are two groups of eight addresses (0000 xxx and 1111 xxx) that are reserved for the special functions, such as a system General Call address. If the user of this device choses to set the Control Code to either “1111” or “0000” in a system with other slave device, please consult the I²C-bus specification and user manual to understand the addressing and implementation of these special functions, to insure reliable operation.

In the read and write command address structure, there are a total of 11 bits of addressing, each pointing to a unique byte of information, resulting in a total address space of 16K bytes. The valid addresses are shown in the memory map in Figure 100.

With the exception of the Current Address Read command, all commands will have the Control Byte followed by the Word Address.

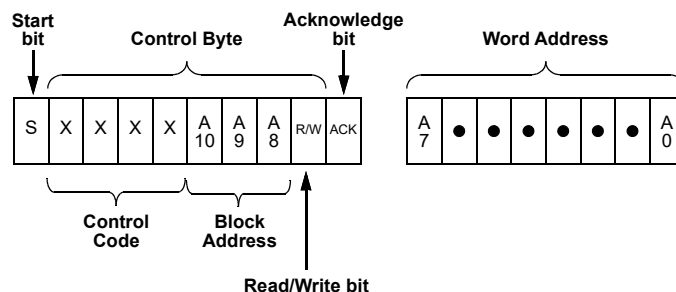

Figure 90: Basic Command Structure

SLG46827-A

Auto AEC-Q100 Qualified GreenPAK Programmable Mixed-Signal Matrix with In-System Debug

15.3 I²C SERIAL GENERAL TIMING

General timing characteristics for the I²C Serial Communications macrocell are shown in Figure 91. Timing specifications can be found in the Section 3.4.

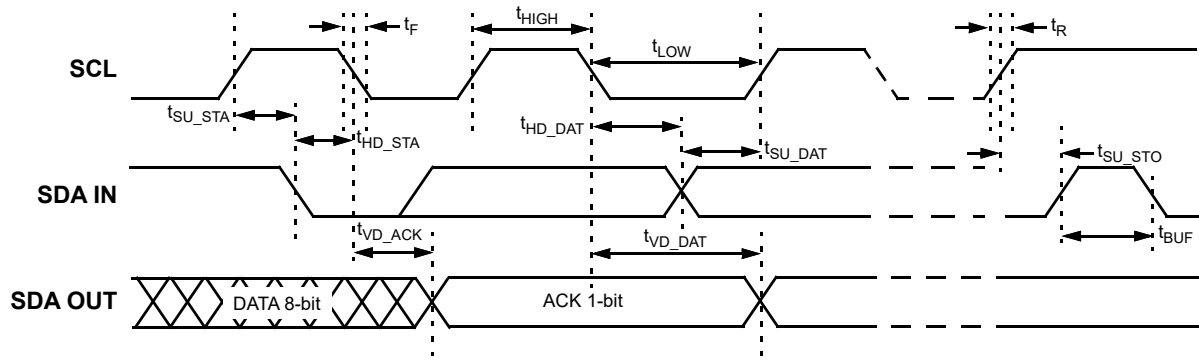

Figure 91: I²C General Timing Characteristics

15.4 I²C SERIAL COMMUNICATIONS COMMANDS

15.4.1 Byte Write Command

Following the Start condition from the Master, the Control Code [4 bits], the Block Address [3 bits], and the R/W bit (set to “0”) are placed onto the I²C bus by the Master. After the SLG46827-A sends an Acknowledge bit (ACK), the next byte transmitted by the Master is the Word Address. The Block Address (A10, A9, A8), combined with the Word Address (A7 through A0), together set the internal address pointer in the SLG46827-A, where the data byte is to be written. After the SLG46827-A sends another Acknowledge bit, the Master will transmit the data byte to be written into the addressed memory location. The SLG46827-A again provides an Acknowledge bit and then the Master generates a Stop condition. The internal write cycle for the data will take place at the time that the SLG46827-A generates the Acknowledge bit.

It is possible to latch all IOs during I²C write command to the register configuration data (block address A10, A9, A8 = 000), register [1602] = 0 - Enable. It means that IOs will remain their state until the write command is done.

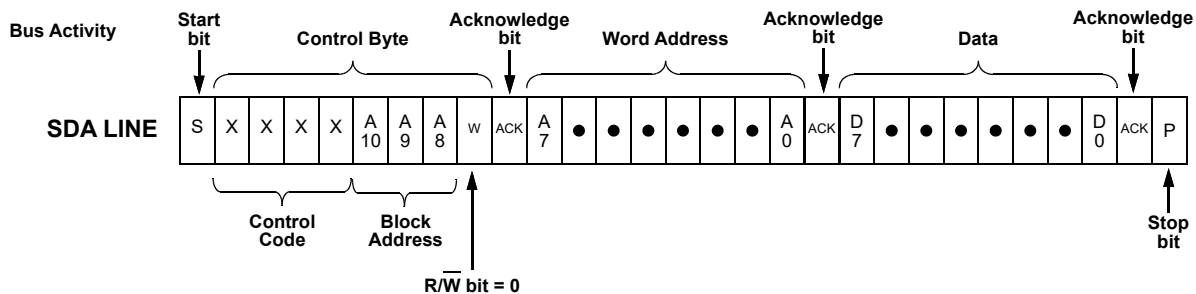

Figure 92: Byte Write Command, R/W = 0

SLG46827-A

Auto AEC-Q100 Qualified GreenPAK Programmable Mixed-Signal Matrix with In-System Debug

15.4.2 Sequential Write Command

The write Control Byte, Word Address, and the first data byte are transmitted to the SLG46827-A in the same way as in a Byte Write command. However, instead of generating a Stop condition, the Bus Master continues to transmit data bytes to the SLG46827-A. Each subsequent data byte will increment the internal address counter, and will be written into the next higher byte in the command addressing. As in the case of the Byte Write command, the internal write cycle will take place at the time that the SLG46827-A generates the Acknowledge bit.

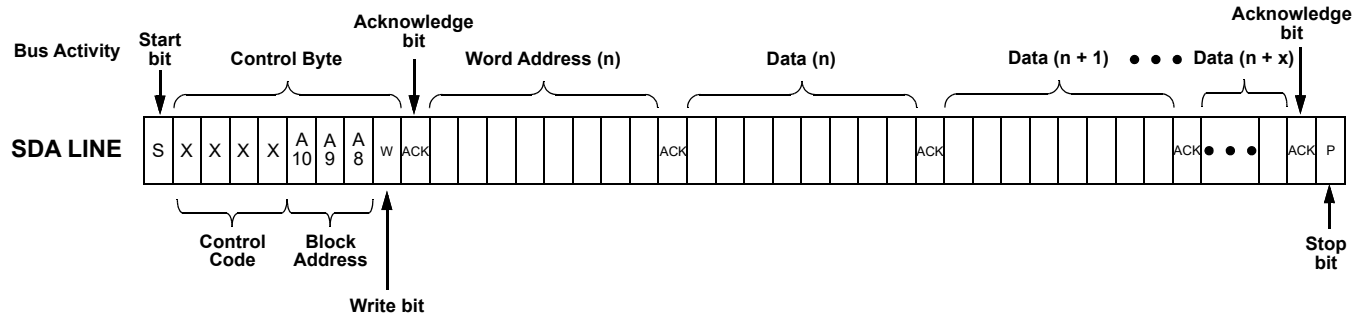

Figure 93: Sequential Write Command

15.4.3 Current Address Read Command

The Current Address Read Command reads from the current pointer address location. The address pointer is incremented at the first STOP bit following any write control byte. For example, if a Sequential Read command (which contains a write control byte) reads data up to address n, the address pointer would get incremented to n + 1 upon the STOP of that command. Subsequently, a Current Address Read that follows would start reading data at n + 1. The Current Address Read Command contains the Control Byte sent by the Master, with the R/W bit = "1". The SLG46827-A will issue an Acknowledge bit, and then transmit eight data bits for the requested byte. The Master will not issue an Acknowledge bit, and follow immediately with a Stop condition.

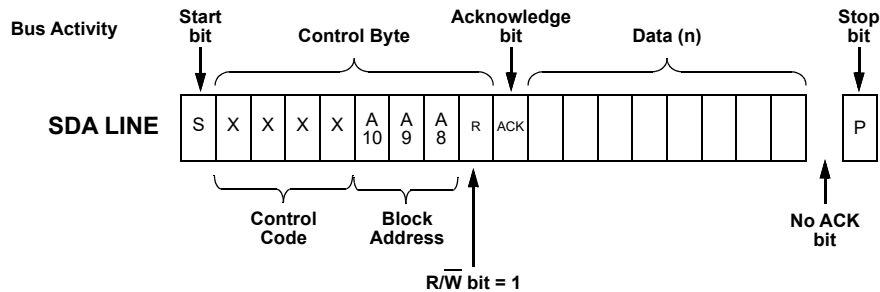

Figure 94: Current Address Read Command, $\overline{R/W} = 1$

15.4.4 Random Read Command

The Random Read command starts with a Control Byte (with R/W bit set to "0", indicating a write command) and Word Address to set the internal byte address, followed by a Start bit, and then the Control Byte for the read (exactly the same as the Byte Write command). The Start bit in the middle of the command will halt the decoding of a Write command, but will set the internal address counter in preparation for the second half of the command. After the Start bit, the Bus Master issues a second control byte with the R/W bit set to "1", after which the SLG46827-A issues an Acknowledge bit, followed by the requested eight data bits.

SLG46827-A

Auto AEC-Q100 Qualified GreenPAK Programmable Mixed-Signal Matrix with In-System Debug

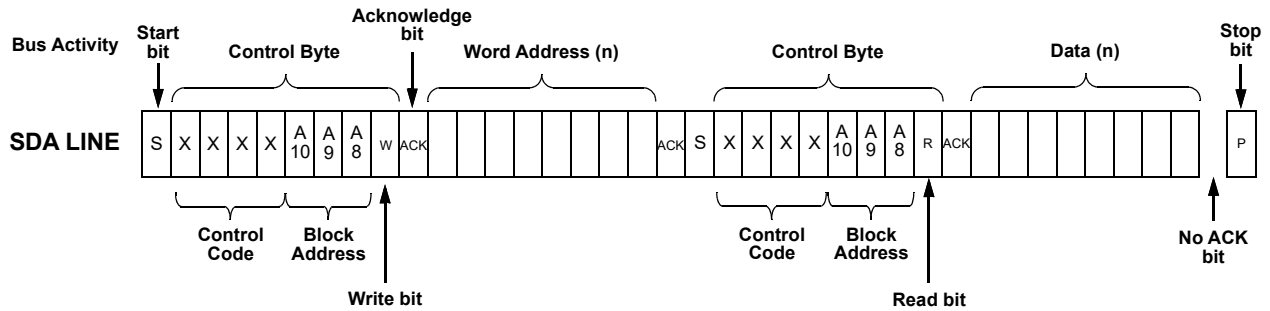

Figure 95: Random Read Command

15.4.5 Sequential Read Command

The Sequential Read command is initiated in the same way as a Random Read command, except that once the SLG46827-A transmits the first data byte, the Bus Master issues an Acknowledge bit as opposed to a Stop condition in a random read. The Bus Master can continue reading sequential bytes of data, and will terminate the command with a Stop condition.

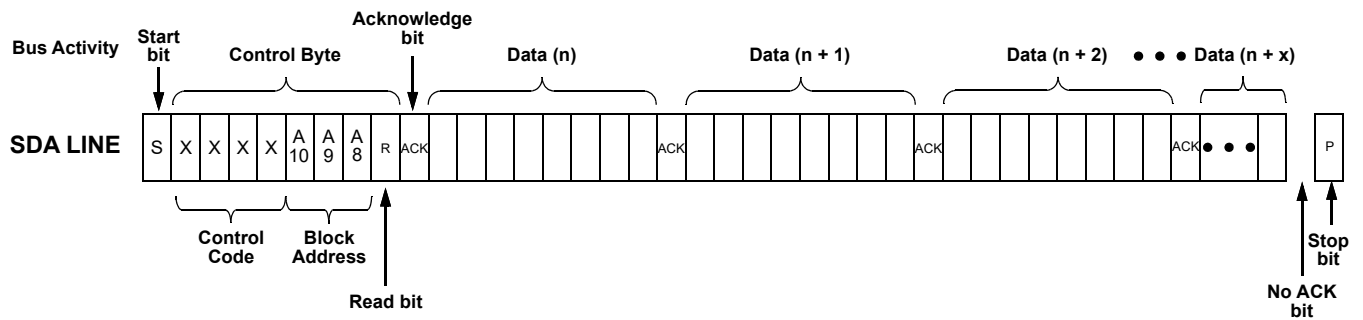

Figure 96: Sequential Read Command

15.4.6 I²C Serial Reset Command

If I²C serial communication is established with the device, it is possible to reset the device to initial power up conditions, including configuration of all macrocells, and all connections provided by the Connection Matrix. This is implemented by setting register [1601] I²C reset bit to “1”, which causes the device to re-enable the Power-On Reset (POR) sequence, including the reload of all register data from NVM. During the POR sequence, the outputs of the device will be in tri-state. After the reset has taken place, the contents of register [1601] will be set to “0” automatically. Figure 97 illustrates the sequence of events for this reset function.

SLG46827-A

Auto AEC-Q100 Qualified GreenPAK Programmable Mixed-Signal Matrix with In-System Debug

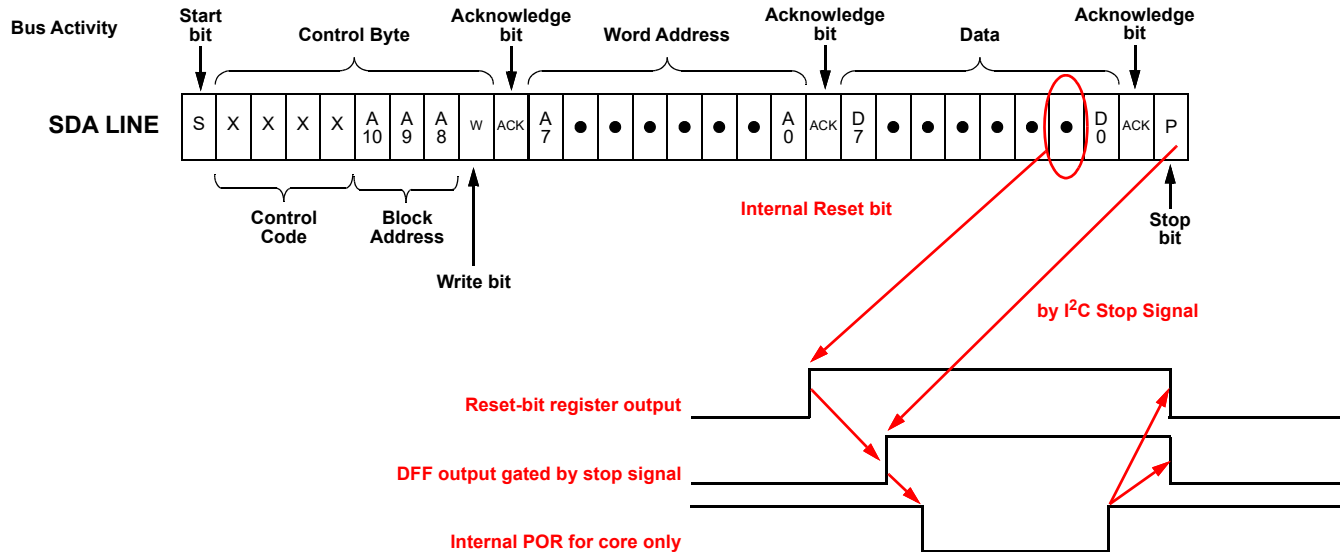

Figure 97: Reset Command Timing

15.5 CHIP CONFIGURATION DATA PROTECTION

The SLG46827-A utilizes a scheme that allows a portion or the entire Register and NVM to be inhibited from being read or written/erased. There are two bytes that define the register and NVM access or change. The first byte RPR defines the 2k register read and write protection. The second byte NPR defines the 2k NVM data configuration read and write protection. If desired, the protection lock bit (PRL) can be set so that protection may no longer be modified, thereby making the current protection scheme permanent. The status of the RPR and NPR can be determined by following a Random Read sequence. Changing the state of the RPR and NPR is accomplished with a Byte Write sequence with the requirements outlined in this section.

The RPR register is located on H'E0 address, while NPR is located on H'E1 address.

The RPR format is shown in Table 51, and the RPR bit functions are included in Table 52.

Table 51: RPR Format

	b7	b6	b5	b4	b3	b2	b1	b0
RPR					RPRB3	RPRB2	RPRB1	RPRB0

Table 52: RPR Bit Function Description

Bit	Name		Type	Description
3:2	RPRB3	2k Register Write Selection Bits	R/W*	00: 2k register data is unprotected for write; 01: 2k register data is partly protected for write; Please refer to the Table 55. 10: 2k register data is fully protected for write.
	RPRB2		R/W*	
1:0	RPRB1	2k Register Read Selection Bits	R/W*	00: 2k register data is unprotected for read; 01: 2k register data is partly protected for read; Please refer to the Table 55. 10: 2k register data is fully protected for read.
	RPRB0		R/W*	

* Becomes read only after PRL is high. The content is permanently locked for write and erase after PRL is high.

SLG46827-A

Auto AEC-Q100 Qualified GreenPAK Programmable Mixed-Signal Matrix with In-System Debug

The NPR format is shown in [Table 53](#), and the NPR bit functions are included in [Table 54](#).

Table 53: NPR Format

	b7	b6	b5	b4	b3	b2	b1	b0
NPR							NPRB1	NPRB0

Table 54: NPR Bit Function Description

Bit	Name	Type	Description
1:0	NPRB1	R/W*	00: 2k NVM Configuration data is unprotected for read and write/erase; 01: 2k NVM Configuration data is fully protected for read; 10: 2k NVM Configuration data is fully protected for write/erase. 11: 2k NVM Configuration data is fully protected for read and write/erase.
	NPRB0	R/W*	

* Becomes read only after PRL is high. The content is permanently locked for write and erase after PRL is high.

The protection selection bits allow different levels of protection of the register and NVM Memory Array.

The Protect Lock Bit (PRL) is used to permanently lock (for write and erase) the current state of the RPR and NPR. A Logic 0 indicates that the protection byte can be modified, whereas a Logic 1 indicates the byte has been locked and can no longer be modified.

In this case it is impossible to erase the whole page E with protection bytes. The PRL is located at E4 address (register [1824]).

15.6 I²C SERIAL COMMAND REGISTER MAP

There are nine read/write protect modes for the design sequence from being corrupted or copied. See [Table 55](#) for details.

Table 55: Read/Write Register Protection Options

Configurations	Protection Modes Configuration									Test Mode	Register Address
	Unlock	Partly Lock Read	Partly Lock Write	Partly Lock Read/Write	Partly Lock Read & Lock Write	Lock Read & Partly Lock Write	Lock Read	Lock Write	Lock Read/Write (Note 3)		
RPR[1:0]	00	01	00	01	01	10	10	00	10		
RPR[3:2]	00	00	01	01	10	01	00	10	10		
I ² C Byte Write Bit Masking (section 15.7.3)	R/W	R/W	R/W	R/W	R	W	W	R	-	-	C9
I ² C Serial Reset Command (section 15.4.6)	R/W	R/W	R/W	R/W	R	W	W	R	-	-	C8b'1
Outputs Latching During I ² C Write	R/W	R/W	R/W	R/W	R	W	W	R	-	-	C8b'2
Connection Matrix Virtual Inputs (section 6.3)	R/W	R/W	R/W	R/W	R	W	W	R	-	-	7A
Configuration Bits for All Macrocells (IOs, ACMPs, Combination Function Macrocells, etc.)	R/W	W	R	-	-	-	W	R	-	-	
Macrocells Inputs Configuration (Connection Matrix Outputs)	R/W	W	R	-	-	-	W	R	-	-	00~47

SLG46827-A

Auto AEC-Q100 Qualified GreenPAK Programmable Mixed-Signal Matrix with In-System Debug

Table 55: Read/Write Register Protection Options(Continued)

Configurations	Protection Modes Configuration									Test Mode	Register Address
	Unlock	Partly Lock Read	Partly Lock Write	Partly Lock Read/Write	Partly Lock Read & Lock Write	Lock Read & Partly Lock Write	Lock Read	Lock Write	Lock Read/Write (Note 3)		
RPR[1:0]	00	01	00	01	01	10	10	00	10		
RPR[3:2]	00	00	01	01	10	01	00	10	10		
Protection Mode Selection	R/W	R/W	R	R	R	R	R/W	R	R	R	E4
Macrocells Output Values (Connection Matrix Inputs, section)	R	R	R	R	R	-	-	R	-	R	74~79;7B
Counter Current Value	R	R	R	R	R	-	-	R	-	R	7C~7F
Silicon Identification Service Bits	R	R	R	R	R	R	R	R	R	R	F9b'3~F9b'2
I ² C Control Code	R/W	R/W	R	R	R	R	R/W	R	R	R	CAb'3~CAb'0
Page Erase byte	W**	W**	W**	W**	W**	W**	W**	W**	W**	W**	E3

R/W	Allow Read and Write Data
W	Allow Write Data Only
W**	Pages that can be erased are defined by NVM write protection
R	Allow Read Data Only
-	The Data is protected for Read and Write

Note 1 R/W becomes read only if protection mode selection (lock bit) is set to 1.

Note 2 R/W Readable/writable depend on the "Trim mode enable" bit. If "Trim mode enable" bit value = 1, then trim bits are enable.

Note 3 Valid for designs where IO1 is configured as input or not used.

It is possible to read some data from macrocells, such as counter current value, connection matrix, and connection matrix virtual inputs. The I²C write will not have any impact on data in case data comes from macrocell output, except Connection Matrix Virtual Inputs. The silicon identification service bits allows identifying silicon family, its revision, and others.

See Section 18 for detailed information on all registers.

15.7 I²C ADDITIONAL OPTIONS

When Output latching during I²C write to the register configuration data (block address A10,A9,A8 = 000), register [1602] = 0 allows all PINs output value to be latched while register content is changing. It will protect the output change due to configuration process during I²C write in case multiple register bytes are changed. Inputs and internal macrocells retain their status during I²C write.

See Section 18 for detailed information on all registers.

SLG46827-A

Auto AEC-Q100 Qualified GreenPAK Programmable Mixed-Signal Matrix with In-System Debug

15.7.1 Reading Counter Data via I²C

The current count value in three counters in the device can be read via I²C. The counters that have this additional functionality are 16-bit CNT0, and 8-bit counters CNT2 and CNT4.

15.7.2 I²C Expander

In addition to the eight Connection Matrix Virtual Inputs, the SLG46827-A chip has four pins which can be used as an I²C Expander. These four pins are IO0, IO5, IO6, and IO9.

Each of these pins can be used as an I²C Expander output or used as a normal pin. Also, each of these four expander outputs have initial state settings which are specified in registers [1599:1592].

15.7.3 I²C Byte Write Bit Masking

The I²C macrocell inside SLG46827-A supports masking of individual bits within a byte that is written to the RAM memory space. This function is supported across the entire RAM memory space. To implement this function, the user performs a Byte Write Command (see Section 15.4.1 for details) on the I²C Byte Write Mask Register (address 0C9H) with the desired bit mask pattern. This sets a bit mask pattern for the target memory location that will take effect on the next Byte Write Command to this register byte. Any bit in the mask that is set to “1” in the I²C Byte Write Mask Register will mask the effect of changing that particular bit in the target register, during the next Byte Write Command. The contents of the I²C Byte Write Mask Register are reset (set to 00h) after valid Byte Write Command. If the next command received by the device is not a Byte Write Command, the effect of the bit masking function will be aborted, and the I²C Byte Write Mask Register will be reset with no effect. Figure 98 shows an example of this function.

SLG46827-A

Auto AEC-Q100 Qualified GreenPAK
Programmable Mixed-Signal Matrix with In-System Debug

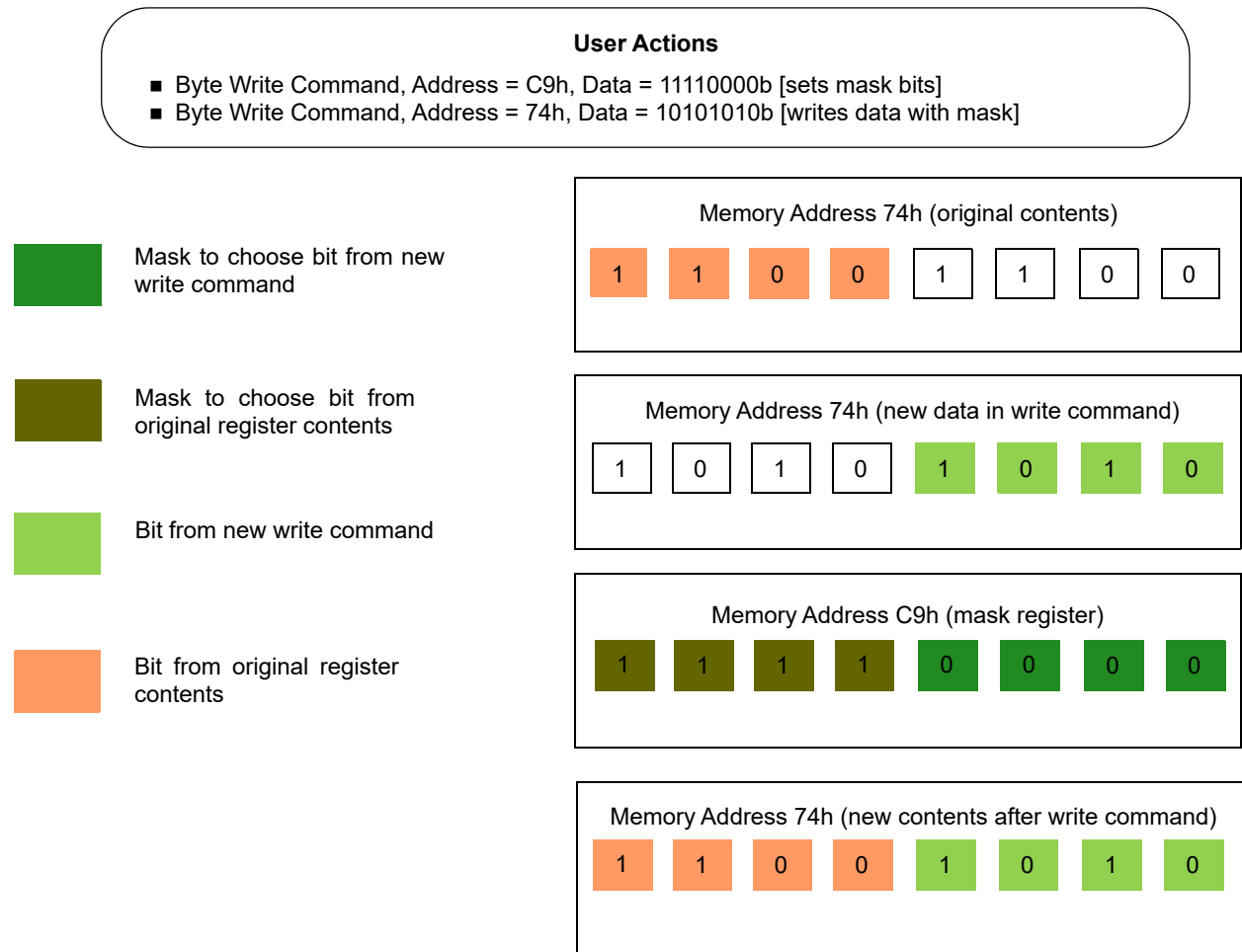

Figure 98: Example of I²C Byte Write Bit Masking

SLG46827-A

Auto AEC-Q100 Qualified GreenPAK Programmable Mixed-Signal Matrix with In-System Debug

16 Non-Volatile Memory

The SLG46827-A provides 2,048 bits of Serial Electrically Erasable Configuration Register memory that is used for device configuration. Write protection settings of the device will be permanently disabled once the GreenPAK design is finalized and enters production.

Key features:

- Low-voltage Operation
 - for Read: VCC = 2.3 V to 5.5 V
 - for Write: VCC = 2.5 V to 5.5 V
- I²C-Compatible (2-Wire) Serial Interface
 - 100 kHz Standard Mode
 - 400 kHz Fast Mode (FM)
- Low Current Consumption
 - Read Current 0.5 mA max
 - Page Write Current 3.0 mA max
 - Chip Erase Current 3.0 mA max
 - Standby Current (1.0 μA max)
- 16-byte Page Write Mode
- Self-timed Write/Erase Cycle (20 ms max)
- Reliability
 - Endurance: 1,000 write cycles
 - Data retention: 10 years at 125 °C

16.1 SERIAL NVM WRITE OPERATIONS

Write access to the NVM is possible in development by setting A3, A2, A1, A0 to “0000”, which allows serial write data for a single page only. Upon receipt of the proper Control Byte and Word Address bytes, the SLG46827-A will send an ACK. The device will then be ready to receive page data, which is 16 sequential writes of 8-bit data words. The SLG46827-A will respond with an ACK after each data word is received. The addressing device, such as a bus Master, must then terminate the write operation with a Stop condition after all page data is written. At that time the device will enter an internally self-timed write cycle, which will be completed within t_{WR} . While the data is being written into the NVM Memory Array, all inputs, outputs, internal logic, and I²C access to the Register data will be operational/valid. Please refer to [Figure 100](#) for the SLG46827-A Memory Map.

Note: The 16 programmed bytes should be in the same page. Any I²C command that does not meet specific requirements will be ignored and NVM will remain unprogrammed.

Data “1” cannot be re-programmed as data “0” without erasure. Each byte can only be programmed one time without erasure.

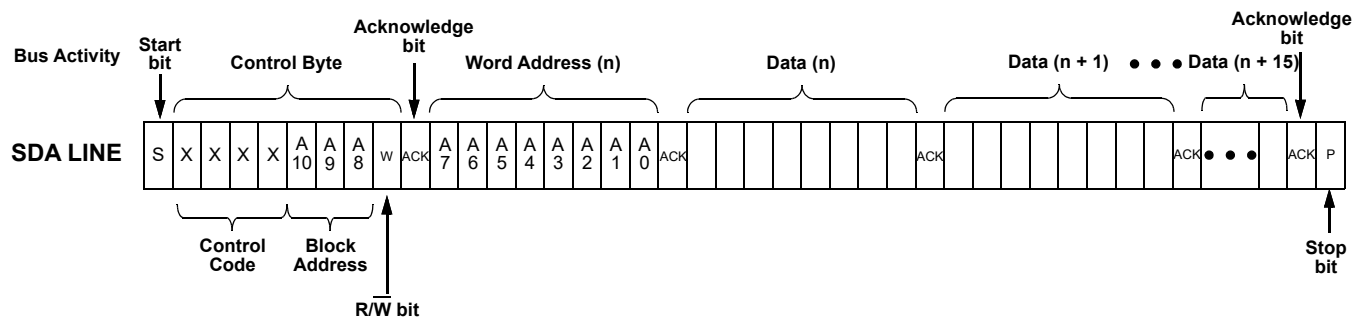

Figure 99: Page Write Command

A10 will be ignored during communication to SLG46827-A.

A9 = 1 will enable access to the NVM.

SLG46827-A

Auto AEC-Q100 Qualified GreenPAK Programmable Mixed-Signal Matrix with In-System Debug

A9 = 1 and A8 = 0 corresponds to the 2K bits chip configuration NVM data.

A3, A2, A1, and A0 should be 0000 for the page write operation.

In a single page, if the data written to any byte is 00H, the contents of the matching byte in NVM memory will not be altered.

		I²C Block Address			Memory Space
Lowest I ² C Address = 000h	A10 = 0	A9 = 0	A8 = X	2 Kbits Register Data Configuration	
	A10 = 0	A9 = 1	A8 = 0	2 Kbits NVM Data Configuration	
	A10 = 0	A9 = 1	A8 = 1	Not Used	
Highest I ² C Address = 7FFh	A10 = 1	A9 = X	A8 = X	Not Used	

Figure 100: I²C Block Addressing

SLG46827-A

Auto AEC-Q100 Qualified GreenPAK Programmable Mixed-Signal Matrix with In-System Debug

16.2 SERIAL NVM READ OPERATIONS

There are three read operations:

- Current Address Read
- Random Address Read
- Sequential Read

Please refer to the Section 15 for more details.

16.3 SERIAL NVM ERASE OPERATIONS

The erase scheme allows a 16 byte page in the NVM chip configuration space to be erased by modifying the contents of the Erase Register (ERSR). When the ERSE bit is set in the ERSR register, the device will start a self-timed erase cycle which will complete in a maximum of t_{ER} ms.

The V_{DD} pin requires a voltage ranging from 2.5 V to 5.5 V for Programming and Erase operations.

Changing the state of the ERSR is accomplished with a Byte Write sequence with the requirements outlined in this section.

The ERSR register is located on I²C Block Address = 000b, I²C Word Address = E3H.

The ERSR format is shown in Table 56, and the ERSR bit functions are included in Table 57.

Table 56: Erase Register Bit format

	b7	b6	b5	b4	b3	b2	b1	b0
Page Erase Register	ERSE	--	--	ERSEB4	ERSEB3	ERSEB2	ERSEB1	ERSEB0

Table 57: Erase Register Bit Function Description

Bit	Name	Type	Description
7	ERSE	Erase Enable	Setting b7 bit to "1" will start an internal erase cycle on the page defined by ERSEB4-0
6	--	--	--
5	--	--	--
4	ERSEB4	W	Define the page address, which will be erased. ERSB4 = 0 corresponds to the Upper 2K NVM used for chip configuration;
3	ERSEB3	W	
2	ERSEB2	W	
1	ERSEB1	W	
0	ERSEB0	W	

Upon receipt of the proper Device Address and Erase Register Address, the SLG46827-A will send an ACK. The device will then be ready to receive Erase Register data. The SLG46827-A will respond with an ACK after Erase Register data word is received. The addressing device, such as a bus Master, must then terminate the write operation with a Stop condition. At that time the device will enter an internally self-timed erase cycle, which will be completed within t_{ER} ms. While the data is being written into the Memory Array, all inputs, outputs, internal logic, and I²C access to the Register data will be operational/valid.

After the erase has taken place, the contents of ERSE bits will be set to "0" automatically. The internal erase cycle will be triggered at the time the Stop Bit in the I²C command is received.

SLG46827-A

Auto AEC-Q100 Qualified GreenPAK Programmable Mixed-Signal Matrix with In-System Debug

17 Analog Temperature Sensor

The SLG46827-A has an Analog Temperature sensor (TS) with an output voltage linearly-proportional to the Centigrade temperature. The TS cell shares buffer with Vref0, so it is impossible to use both cells simultaneously, its output can be connected directly to the IO10 or to the ACPM3_L positive input. Using buffer causes low-output impedance, linear output, and makes interfacing to readout or control circuitry especially easy. The TS is rated to operate over a -40 °C to 105 °C temperature range. The error in the whole temperature range does not exceed ±0.85 %. TS output voltage variation over V_{DD} at constant temperature is less than ±0.08 %. For more detail refer to Section 3.

The equation below calculates the typical analog voltage passed from the TS to the ACMPs' IN+ source input. It is important to note that there will be a chip to chip variation of about ±2 °C.

$$V_{TS1} = -2.3 \times T + 904.5$$

$$V_{TS2} = -2.8 \times T + 1092.8$$

where:

V_{TS1} (mV) - TS Output Voltage, range 1 (0.62 V to 0.95 V)

V_{TS2} (mV) - TS Output Voltage, range 2 (0.75 V to 1.2 V)

T (°C) - Temperature

SLG46827-A

Auto AEC-Q100 Qualified GreenPAK
 Programmable Mixed-Signal Matrix with In-System Debug

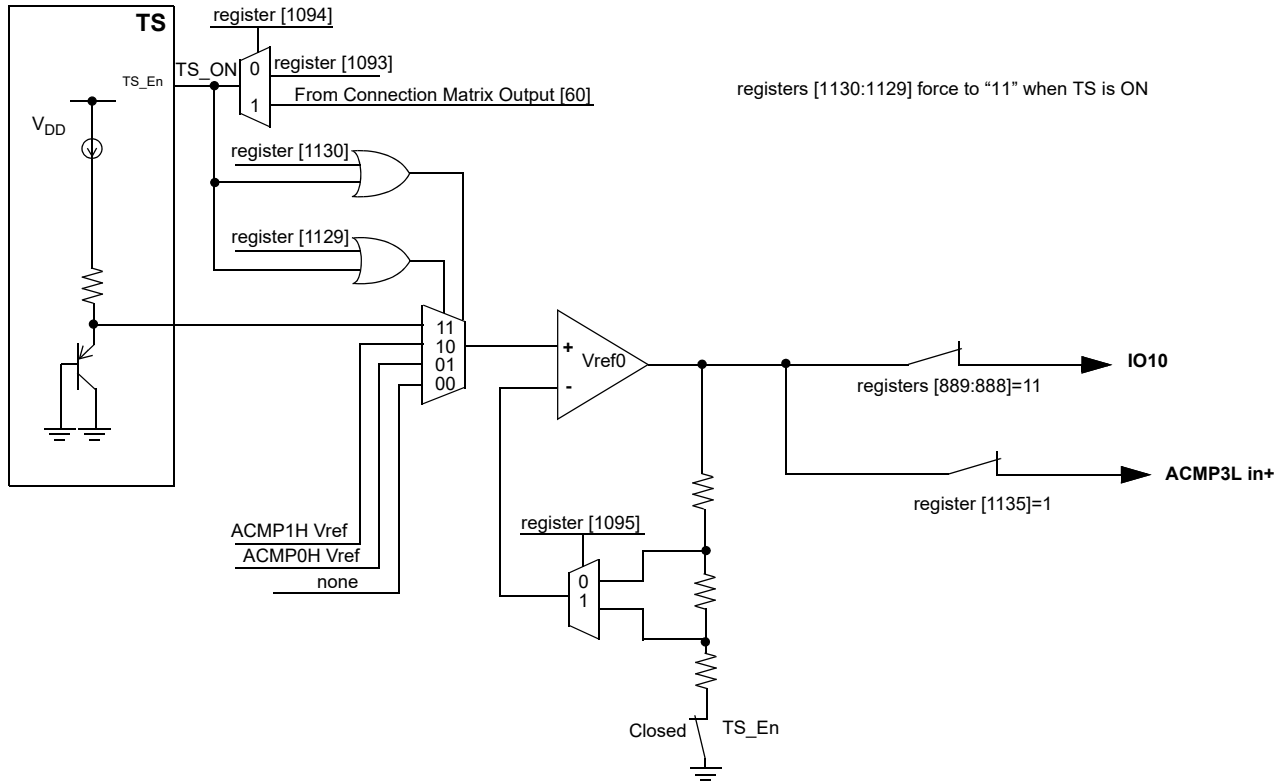

Note: In order to use TS, BG must be enabled.

Figure 101: Analog Temperature Sensor Structure Diagram

SLG46827-A

Auto AEC-Q100 Qualified GreenPAK
 Programmable Mixed-Signal Matrix with In-System Debug

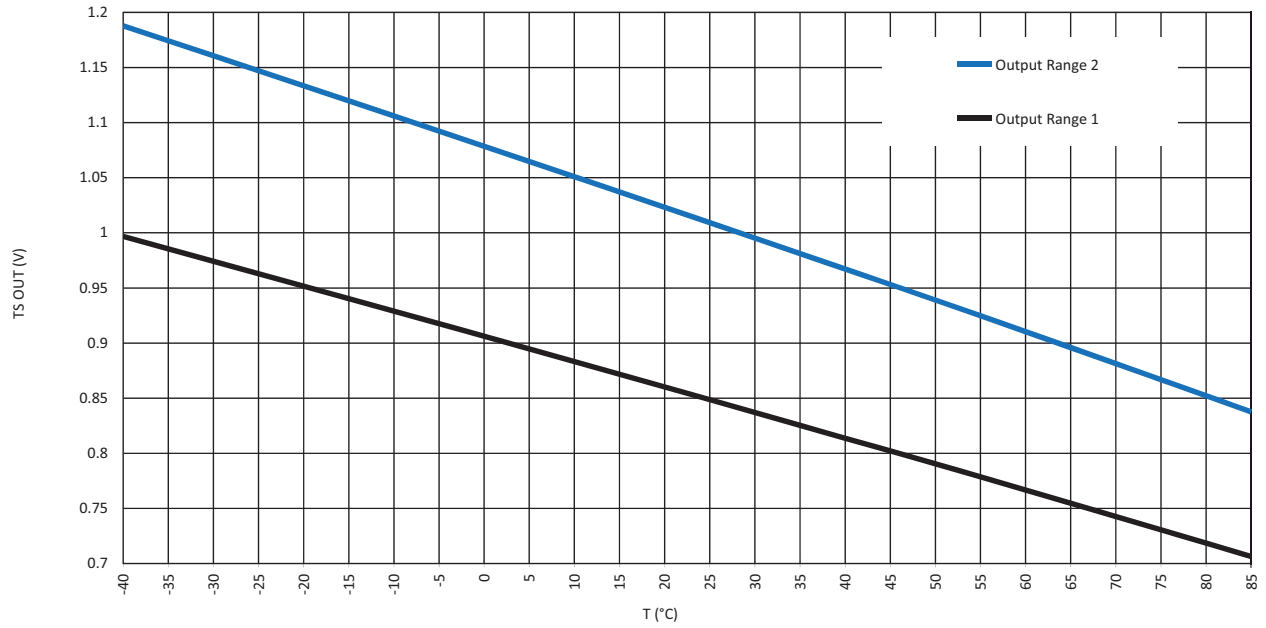

Figure 102: Typical TS Output vs Temperature, $V_{DD} = 2.3\text{ V to }5.5\text{ V}$

SLG46827-A

Auto AEC-Q100 Qualified GreenPAK Programmable Mixed-Signal Matrix with In-System Debug

18 Register Definitions

18.1 REGISTER MAP

Table 58: Register Map

Address		Signal Function	Register Bit Definition
Byte	Register Bit		
Matrix Output			
00	5:0	Matrix OUT0	IN0 of LUT2_0 or Clock Input of DFF0
00 01	11:6	Matrix OUT1	IN1 of LUT2_0 or Data Input of DFF0
01 02	17:12	Matrix OUT2	IN0 of LUT2_3 or Clock Input of PGen
02	23:18	Matrix OUT3	IN1 of LUT2_3 or nRST of PGen
03	29:24	Matrix OUT4	IN0 of LUT2_1 or Clock Input of DFF1
03 04	35:30	Matrix OUT5	IN1 of LUT2_1 or Data Input of DFF1
04 05	41:36	Matrix OUT6	IN0 of LUT2_2 or Clock Input of DFF2
05	47:42	Matrix OUT7	IN1 of LUT2_2 or Data Input of DFF2
06	53:48	Matrix OUT8	IN0 of LUT3_0 or Clock Input of DFF3
06 07	59:54	Matrix OUT9	IN1 of LUT3_0 or Data Input of DFF3
07 08	65:60	Matrix OUT10	IN2 of LUT3_0 or nRST(nSET) of DFF3
08	71:66	Matrix OUT11	IN0 of LUT3_1 or Clock Input of DFF4
09	77:72	Matrix OUT12	IN1 of LUT3_1 or Data Input of DFF4
09 0A	83:78	Matrix OUT13	IN2 of LUT3_1 or nRST(nSET) of DFF4
0A 0B	89:84	Matrix OUT14	IN0 of LUT3_2 or Clock Input of DFF5
0B	95:90	Matrix OUT15	IN1 of LUT3_2 or Data Input of DFF5
0C	101:96	Matrix OUT16	IN2 of LUT3_2 or nRST(nSET) of DFF5
0C 0D	107:102	Matrix OUT17	IN0 of LUT3_3 or Clock Input of DFF6
0D 0E	113:108	Matrix OUT18	IN1 of LUT3_3 or Data Input of DFF6
0E	119:114	Matrix OUT19	IN2 of LUT3_3 or nRST(nSET) of DFF6
0F	125:120	Matrix OUT20	IN0 of LUT3_4 or Clock Input of DFF7
0F 10	131:126	Matrix OUT21	IN1 of LUT3_4 or Data Input of DFF7
10 11	137:132	Matrix OUT22	IN2 of LUT3_4 or nRST(nSET) of DFF7
11	143:138	Matrix OUT23	IN0 of LUT3_5 or Clock Input of DFF8
12	149:144	Matrix OUT24	IN1 of LUT3_5 or Data Input of DFF8

SLG46827-A

Auto AEC-Q100 Qualified GreenPAK Programmable Mixed-Signal Matrix with In-System Debug

Table 58: Register Map (Continued)

Address		Signal Function	Register Bit Definition
Byte	Register Bit		
12	155:150	Matrix OUT25	IN2 of LUT3_5 or nRST(nSET) of DFF8
13			
13	161:156	Matrix OUT26	IN0 of LUT3_6 or Input of Pipe Delay or UP Signal of RIPP CNT
14			
14	167:162	Matrix OUT27	IN1 of LUT3_6 or nRST of Pipe Delay or STB of RIPP CNT
15	173:168	Matrix OUT28	IN2 of LUT3_6 or Clock of Pipe Delay_RIPP_CNT
15	179:174	Matrix OUT29	Reserved
16			
16	185:180	Matrix OUT30	MULTFUNC_16BIT_0: IN0 of LUT4_0 or Clock Input of DFF9; Delay0 Input (or Counter0 nRST/SET Input)
17			
17	191:186	Matrix OUT31	MULTFUNC_16BIT_0: IN1 of LUT4_0 or nRST of DFF9; Delay0 Input (or Counter0 nRST Input) or Delay/Counter0 External Clock Source
18	197:192	Matrix OUT32	MULTFUNC_16BIT_0: IN2 of LUT4_0 or nSET of DFF9; Delay0 Input (or Counter0 nRST Input) or Delay/Counter0 External Clock Source or KEEP Input of FSM0
18	203:198	Matrix OUT33	MULTFUNC_16BIT_0: IN3 of LUT4_0 or Data Input of DFF9; Delay0 Input (or Counter0 nRST Input) or UP Input of FSM0
19			
19	209:204	Matrix OUT34	MULTFUNC_8BIT_1: IN0 of LUT3_7 or Clock Input of DFF10; Delay1 Input (or Counter1 nRST Input)
1A			
1A	215:210	Matrix OUT35	MULTFUNC_8BIT_1: IN1 of LUT3_7 or nRST (nSET) of DFF10; Delay1 Input (or Counter1 nRST Input) or Delay/Counter1 External Clock Source
1B	221:216	Matrix OUT36	MULTFUNC_8BIT_1: IN2 of LUT3_7 or Data Input of DFF10; Delay1 Input (or Counter1 nRST Input)
1B	227:222	Matrix OUT37	MULTFUNC_8BIT_2: IN0 of LUT3_8 or Clock Input of DFF11; Delay2 Input (or Counter2 nRST Input)
1C			
1C	233:228	Matrix OUT38	MULTFUNC_8BIT_2: IN1 of LUT3_8 or nRST (nSET) of DFF11; Delay2 Input (or Counter2 nRST Input) or Delay/Counter2 External Clock Source
1D			
1D	239:234	Matrix OUT39	MULTFUNC_8BIT_2: IN2 of LUT3_8 or Data Input of DFF11; Delay2 Input (or Counter2 nRST Input)
1E	245:240	Matrix OUT40	MULTFUNC_8BIT_3: IN0 of LUT3_9 or Clock Input of DFF12; Delay3 Input (or Counter3 nRST Input)
1E	251:246	Matrix OUT41	MULTFUNC_8BIT_3: IN1 of LUT3_9 or nRST (nSET) of DFF12; Delay3 Input (or Counter3 nRST Input) or Delay/Counter3 External Clock Source
1F			

SLG46827-A

Auto AEC-Q100 Qualified GreenPAK Programmable Mixed-Signal Matrix with In-System Debug

Table 58: Register Map (Continued)

Address		Signal Function	Register Bit Definition
Byte	Register Bit		
1F	257:252	Matrix OUT42	MULTFUNC_8BIT_3: IN2 of LUT3_9 or Data Input of DFF12; Delay3 Input (or Counter3 nRST Input)
20			
20	263:258	Matrix OUT43	MULTFUNC_8BIT_4: IN0 of LUT3_10 or Clock Input of DFF13; Delay4 Input (or Counter4 nRST Input)
21	269:264	Matrix OUT44	MULTFUNC_8BIT_4: IN1 of LUT3_10 or nRST (nSET) of DFF13; Delay4 Input (or Counter4 nRST Input) or Delay/Counter4 External Clock Source
21	275:270	Matrix OUT45	MULTFUNC_8BIT_4: IN2 of LUT3_10 or Data Input of DFF13; Delay4 Input (or Counter4 nRST Input)
22			
22	281:276	Matrix OUT46	MULTFUNC_8BIT_5: IN0 of LUT3_11 or Clock Input of DFF14; Delay5 Input (or Counter5 nRST Input)
23			
23	287:282	Matrix OUT47	MULTFUNC_8BIT_5: IN1 of LUT3_11 or nRST (nSET) of DFF14; Delay5 Input (or Counter5 nRST Input) or Delay/Counter5 External Clock Source
24	293:288	Matrix OUT48	MULTFUNC_8BIT_5: IN2 of LUT3_11 or Data Input of DFF14; Delay5 Input (or Counter5 nRST Input)
24	299:294	Matrix OUT49	MULTFUNC_8BIT_6: IN0 of LUT3_12 or Clock Input of DFF15; Delay6 Input (or Counter6 nRST Input)
25			
25	305:300	Matrix OUT50	MULTFUNC_8BIT_6: IN1 of LUT3_12 or nRST (nSET) of DFF15; Delay6 Input (or Counter6 nRST Input) or Delay/Counter6 External Clock Source
26			
26	311:306	Matrix OUT51	MULTFUNC_8BIT_6: IN2 of LUT3_12 or Data Input of DFF15; Delay6 Input (or Counter6 nRST Input)
27	317:312	Matrix OUT52	MULTFUNC_8BIT_7: IN0 of LUT3_13 or Clock Input of DFF16; Delay7 Input (or Counter7 nRST Input)
27	323:318	Matrix OUT53	MULTFUNC_8BIT_7: IN1 of LUT3_13 or nRST (nSET) of DFF16; Delay7 Input (or Counter7 nRST Input) or Delay/Counter7 External Clock Source
28			
28	329:324	Matrix OUT54	MULTFUNC_8BIT_7: IN2 of LUT3_13 or Data Input of DFF16; Delay7 Input (or Counter7 nRST Input)
29			
29	335:330	Matrix OUT55	Filter/Edge detect input
2A	341:336	Matrix OUT56	Programmable delay/edge detect input
2A	347:342	Matrix OUT57	OSC2 ENABLE from matrix
2B			
2B	353:348	Matrix OUT58	OSC0 ENABLE from matrix
2C			
2C	359:354	Matrix OUT59	OSC1 ENABLE from matrix

SLG46827-A

Auto AEC-Q100 Qualified GreenPAK Programmable Mixed-Signal Matrix with In-System Debug

Table 58: Register Map (Continued)

Address		Signal Function	Register Bit Definition
Byte	Register Bit		
2D	365:360	Matrix OUT60	Temp sensor and Vref PD from matrix
2D	371:366	Matrix OUT61	BG power-down from matrix
2E			
2E	377:372	Matrix OUT62	PWR UP of ACMP0H from matrix
2F			
2F	383:378	Matrix OUT63	PWR UP of ACMP1H from matrix
30	389:384	Matrix OUT64	PWR UP of ACMP2L from matrix
30	395:390	Matrix OUT65	PWR UP of ACMP3L from matrix
31			
31	401:396	Matrix OUT66	Reserved
32			
32	407:402	Matrix OUT67	IO0 Digital Output
33	413:408	Matrix OUT68	IO1 Digital Output
33	419:414	Matrix OUT69	IO1 Digital Output OE
34			
34	425:420	Matrix OUT70	IO2 Digital Output
35			
35	431:426	Matrix OUT71	IO3 Digital Output
36	437:432	Matrix OUT72	IO4 Digital Output
36	443:438	Matrix OUT73	IO4 Digital Output OE
37			
37	449:444	Matrix OUT74	IO5 Digital Output
38			
38	455:450	Matrix OUT75	IO5 Digital Output OE
39	461:456	Matrix OUT76	IO6 Digital Output
39	467:462	Matrix OUT77	IO7 Digital Output
3A			
3A	473:468	Matrix OUT78	IO8 Digital Output
3B			
3B	479:474	Matrix OUT79	IO8 Digital Output OE
3C	485:480	Matrix OUT80	IO9 Digital Output
3C	491:486	Matrix OUT81	IO9 Digital Output OE
3D			
3D	497:492	Matrix OUT82	IO10 Digital Output
3E			
3E	503:498	Matrix OUT83	IO10 Digital Output OE
3F	509:504	Matrix OUT84	IO11 Digital Output
3F	515:510	Matrix OUT85	IO11 Digital Output OE
40			
40	521:516	Matrix OUT86	IO12 Digital Output
41			
41	527:522	Matrix OUT87	IO12 Digital Output OE

SLG46827-A

Auto AEC-Q100 Qualified GreenPAK Programmable Mixed-Signal Matrix with In-System Debug

Table 58: Register Map (Continued)

Address		Signal Function	Register Bit Definition
Byte	Register Bit		
42	533:528	Matrix OUT88	IO13 Digital Output
42	539:534	Matrix OUT89	IO13 Digital Output OE
43			
43	545:540	Matrix OUT90	IO14 Digital Output
44			
44	551:546	Matrix OUT91	IO14 Digital Output OE
45	557:552	Matrix OUT92	Reserved
45	563:558	Matrix OUT93	Reserved
46			
46	569:564	Matrix OUT94	Reserved
47			
47	575:570	Matrix OUT95	Reserved
48	583:576	Reserved	
49	591:584		
4A	599:592	Reserved	
4B	607:600		
4C	615:608	Reserved	
4D	623:616		
4E	631:624	Reserved	
4F	639:632		
50	647:640	Reserved	
51	655:648		
52	663:656	Reserved	
53	671:664		
54	679:672	Reserved	
55	687:680		
56	695:688	Reserved	
57	703:696		
58	711:704		
59	719:712	Reserved	
5A	727:720		
5B	735:728	Reserved	
5C	743:736		
5D	751:744	Reserved	
5E	759:752		
5F	767:760	Reserved	
IO Common			
60	768	IO fast Pull-up/down enable	0: disable 1: enable
	769	I ² C mode selection	0: I ² C standard/fast mode 1: I ² C fast mode+
	775:770	Reserved	

SLG46827-A

Auto AEC-Q100 Qualified GreenPAK Programmable Mixed-Signal Matrix with In-System Debug

Table 58: Register Map (Continued)

Address		Signal Function	Register Bit Definition
Byte	Register Bit		
IO0			
61	777:776	IO0 input mode configuration	00: digital in without Schmitt Trigger 01: digital in with Schmitt Trigger 10: low voltage digital in mode 11: reserved
	779:778	IO0 output mode configuration	00: Push-Pull 1x 01: Push-Pull 2x 10: 1x Open-Drain 11: 2x Open-Drain
	781:780	IO0 Pull-up/down resistance selection	00: floating 01: 10K 10: 100K 11: 1M
	782	IO0 Pull-up/down selection	0: Pull-down 1: Pull-up
	783	IO0 output enable	0: disable 1: enable
IO1			
62	785:784	IO1 input mode configuration	00: digital in without Schmitt Trigger 01: digital in with Schmitt Trigger 10: low voltage digital in mode 11: analog input
	787:786	IO1 output mode configuration	00: Push-Pull 1x 01: Push-Pull 2x 10: 1x Open-Drain 11: 2x Open-Drain
	789:788	IO1 Pull-up/down resistance selection	00: floating 01: 10K 10: 100K 11: 1M
	790	IO1 Pull-up/down selection	0: Pull-down 1: Pull-up
	791	Reserved	
Reserved			
63	793:792	Reserved	
	795:794	Reserved	
	797:796	Reserved	
	798	Reserved	
	799	Reserved	
IO2			

SLG46827-A

Auto AEC-Q100 Qualified GreenPAK Programmable Mixed-Signal Matrix with In-System Debug

Table 58: Register Map (Continued)

Address		Signal Function	Register Bit Definition
Byte	Register Bit		
64	801:800	IO2 input mode configuration	00: digital in without Schmitt Trigger 01: digital in with Schmitt Trigger 10: low voltage digital in mode 11: reserved
	803:802	IO2 output mode configuration	00: Push-Pull 1x 01: Push-Pull 2x 10: 1x Open-Drain 11: 2x Open-Drain
	805:804	IO2 Pull-up/down resistance selection	00: floating 01: 10K 10: 100K 11: 1M
	806	IO2 Pull-up/down selection	0: Pull-down 1: Pull-up
	807	IO2 output enable	0: disable 1: enable
IO3			
65	809:808	IO3 input mode configuration	00: digital in without Schmitt Trigger 01: digital in with Schmitt Trigger 10: low voltage digital in mode 11: reserved
	811:810	IO3 output mode configuration	00: Push-Pull 1x 01: Push-Pull 2x 10: 1x Open-Drain 11: 2x Open-Drain
	813:812	IO3 Pull-up/down resistance selection	00: floating 01: 10K 10: 100K 11: 1M
	814	IO3 Pull-up/down selection	0: Pull-down 1: Pull-up
	815	IO3 output enable	0: disable 1: enable
IO4			
66	817:816	IO4 input mode configuration	00: digital in without Schmitt Trigger 01: digital in with Schmitt Trigger 10: low voltage digital in mode 11: reserved
	819:818	IO4 output mode configuration	00: Push-Pull 1x 01: Push-Pull 2x 10: 1x Open-Drain 11: 2x Open-Drain
	821:820	IO4 Pull-up/down resistance selection	00: floating 01: 10K 10: 100K 11: 1M
	822	IO4 Pull-up/down selection	0: Pull-down 1: Pull-up
	823	Reserved	
IO5			

SLG46827-A

Auto AEC-Q100 Qualified GreenPAK Programmable Mixed-Signal Matrix with In-System Debug

Table 58: Register Map (Continued)

Address		Signal Function	Register Bit Definition
Byte	Register Bit		
67	825:824	IO5 input mode configuration	00: digital in without Schmitt Trigger 01: digital in with Schmitt Trigger 10: low voltage digital in mode 11: reserved
	827:826	IO5 output mode configuration	00: Push-Pull 1x 01: Push-Pull 2x 10: 1x Open-Drain 11: 2x Open-Drain
	829:828	IO5 Pull-up/down resistance selection	00: floating 01: 10K 10: 100K 11: 1M
	830	IO5 Pull-up/down selection	0: Pull-down 1: Pull-up
	831	Reserved	
SCL			
68	832	Reserved	
	834:833	SCL input mode configuration	00: digital in without Schmitt Trigger 01: digital in with Schmitt Trigger 10: low voltage digital in mode 11: Reserved
	836:835	SCL Pull-up/down resistance selection	00: floating 01: Reserved 10: Reserved 11: Reserved
	837	Reserved	
	839:838	Reserved	
SDA			
69	840	Reserved	
	842:841	SDA input mode configuration	00: digital in without Schmitt Trigger 01: digital in with Schmitt Trigger 10: low voltage digital in mode 11: Reserved
	844:843	SDA Pull-up/down resistance selection	00: floating 01: Reserved 10: Reserved 11: Reserved
	845	Reserved	
	847:846	Reserved	
IO6			

SLG46827-A

Auto AEC-Q100 Qualified GreenPAK Programmable Mixed-Signal Matrix with In-System Debug

Table 58: Register Map (Continued)

Address		Signal Function	Register Bit Definition
Byte	Register Bit		
6A	849:848	Reserved	
	851:850	IO6 output mode configuration	00: Push-Pull 1x 01: Push-Pull 2x 10: 1x Open-Drain 11: 2x Open-Drain
	853:852	IO6 Pull-up/down resistance selection	00: floating 01: 10K 10: 100K 11: 1M
	854	IO6 Pull-up/down selection	0: Pull-down 1: Pull-up
	855	IO6 output enable	0: disable 1: enable
IO7			
6B	857:856	Reserved	
	859:858	IO7 output mode configuration	00: Push-Pull 1x 01: Push-Pull 2x 10: 1x Open-Drain 11: 2x Open-Drain
	861:860	IO7 Pull-up/down resistance selection	00: floating 01: 10K 10: 100K 11: 1M
	862	IO7 Pull-up/down selection	0: Pull-down 1: Pull-up
	863	IO7 output enable	0: disable 1: enable
IO8			
6C	865:864	IO8 input mode configuration	00: digital in without Schmitt Trigger 01: digital in with Schmitt Trigger 10: low voltage digital in mode 11: reserved
	867:866	IO8 output mode configuration	00: Push-Pull 1x 01: Push-Pull 2x 10: 1x Open-Drain 11: 2x Open-Drain
	869:868	IO8 Pull-up/down resistance selection	00: floating 01: 10K 10: 100K 11: 1M
	870	IO8 Pull-up/down selection	0: Pull-down 1: Pull-up
	871	Reserved	
Reserved			
6D	873:872	Reserved	
	875:874	Reserved	
	877:876	Reserved	
	878	Reserved	
	879	Reserved	

SLG46827-A

Auto AEC-Q100 Qualified GreenPAK Programmable Mixed-Signal Matrix with In-System Debug

Table 58: Register Map (Continued)

Address		Signal Function	Register Bit Definition
Byte	Register Bit		
IO9			
6E	881:880	IO9 input mode configuration	00: digital in without Schmitt Trigger 01: digital in with Schmitt Trigger 10: low voltage digital in mode 11: analog output
	883:882	IO9 output mode configuration	00: Push-Pull 1x 01: Push-Pull 2x 10: 1x Open-Drain 11: 2x Open-Drain
	885:884	IO9 Pull-up/down resistance selection	00: floating 01: 10K 10: 100K 11: 1M
	886	IO9 Pull-up/down selection	0: Pull-down 1: Pull-up
	887	Reserved	
IO10			
6F	889:888	IO10 input mode configuration	00: digital in without Schmitt Trigger 01: digital in with Schmitt Trigger 10: low voltage digital in mode 11: analog output
	891:890	IO10 output mode configuration	00: Push-Pull 1x 01: Push-Pull 2x 10: 1x Open-Drain 11: 2x Open-Drain
	893:892	IO10 Pull-up/down resistance selection	00: floating 01: 10K 10: 100K 11: 1M
	894	IO10 Pull-up/down selection	0: Pull-down 1: Pull-up
	895	Reserved	
IO11			
70	897:896	IO11 input mode configuration	00: digital in without Schmitt Trigger 01: digital in with Schmitt Trigger 10: low voltage digital in mode 11: analog input
	899:898	IO11 output mode configuration	00: Push-Pull 1x 01: Push-Pull 2x 10: 1x Open-Drain 11: 2x Open-Drain
	901:900	IO11 Pull-up/down resistance selection	00: floating 01: 10K 10: 100K 11: 1M
	902	IO11 Pull-up/down selection	0: Pull-down 1: Pull-up
	903	Reserved	
IO12			

SLG46827-A

Auto AEC-Q100 Qualified GreenPAK Programmable Mixed-Signal Matrix with In-System Debug

Table 58: Register Map (Continued)

Address		Signal Function	Register Bit Definition
Byte	Register Bit		
71	905:904	IO12 input mode configuration	00: digital in without Schmitt Trigger 01: digital in with Schmitt Trigger 10: low voltage digital in mode 11: analog input
	907:906	IO12 output mode configuration	00: Push-Pull 1x 01: Push-Pull 2x 10: 1x Open-Drain 11: 2x Open-Drain
	909:908	IO12 Pull-up/down resistance selection	00: floating 01: 10K 10: 100K 11: 1M
	910	IO12 Pull-up/down selection	0: Pull-down 1: Pull-up
	911	Reserved	
IO13			
72	913:912	IO13 input mode configuration	00: digital in without Schmitt Trigger 01: digital in with Schmitt Trigger 10: low voltage digital in mode 11: analog IO
	915:914	IO13 output mode configuration	00: Push-Pull 1x 01: Push-Pull 2x 10: 1x Open-Drain 11: 2x Open-Drain
	917:916	IO13 Pull-up/down resistance selection	00: floating 01: 10K 10: 100K 11: 1M
	918	IO13 Pull-up/down selection	0: Pull-down 1: Pull-up
	919	Reserved	
IO14			
73	921:920	IO14 input mode configuration	00: digital in without Schmitt Trigger 01: digital in with Schmitt Trigger 10: low voltage digital in mode 11: analog input
	923:922	IO14 output mode configuration	00: Push-Pull 1x 01: Push-Pull 2x 10: 1x Open-Drain 11: 2x Open-Drain
	925:924	IO14 Pull-up/down resistance selection	00: floating 01: 10K 10: 100K 11: 1M
	926	IO14 Pull-up/down selection	0: Pull-down 1: Pull-up
	927	Reserved	
Matrix Input			

SLG46827-A

Auto AEC-Q100 Qualified GreenPAK Programmable Mixed-Signal Matrix with In-System Debug

Table 58: Register Map (Continued)

Address		Signal Function	Register Bit Definition
Byte	Register Bit		
74	928	Matrix Input 0	Tie low
	929	Matrix Input 1	IO0 Digital Input
	930	Matrix Input 2	IO1 Digital Input
	931	Matrix Input 3	IO2 Digital Input
	932	Matrix Input 4	IO3 Digital Input
	933	Matrix Input 5	IO4 Digital Input
	934	Matrix Input 6	IO5 Digital Input
	935	Matrix Input 7	IO8 Digital Input
75	936	Matrix Input 8	IO9 Digital Input
	937	Matrix Input 9	IO10 Digital Input
	938	Matrix Input 10	IO11 Digital Input
	939	Matrix Input 11	IO12 Digital Input
	940	Matrix Input 12	IO13 Digital Input
	941	Matrix Input 13	IO14 Digital Input
	942	Matrix Input 14	LUT2_0_DFF0_OUT
76	943	Matrix Input 15	LUT2_1_DFF1_OUT
	944	Matrix Input 16	LUT2_2_DFF2_OUT
	945	Matrix Input 17	LUT2_3_PGEN_OUT
	946	Matrix Input 18	LUT3_0_DFF3_OUT
	947	Matrix Input 19	LUT3_1_DFF4_OUT
	948	Matrix Input 20	LUT3_2_DFF5_OUT
	949	Matrix Input 21	LUT3_3_DFF6_OUT
	950	Matrix Input 22	LUT3_4_DFF7_OUT
	951	Matrix Input 23	LUT3_5_DFF8_OUT
77	952	Matrix Input 24	LUT3_6_PIPEDLY_RIPP_CNT_OUT0
	953	Matrix Input 25	PIPEDLY_RIPP_CNT_OUT1
	954	Matrix Input 26	RIPP_CNT_OUT2
	955	Matrix Input 27	EDET_FILTER_OUT
	956	Matrix Input 28	PROG_DLY_EDET_OUT
	957	Matrix Input 29	MULTFUNC_8BIT_1: DLY_CNT_OUT
	958	Matrix Input 30	CKOSC1_MATRIX: OSC1 matrix input
	959	Matrix Input 31	CKOSC0_MATRIX: OSC0 matrix input
78	960	Matrix Input 32	CKOSC2_MATRIX: OSC2 matrix input
	961	Matrix Input 33	MULTFUNC_8BIT_2: DLY_CNT_OUT
	962	Matrix Input 34	MULTFUNC_8BIT_3: DLY_CNT_OUT
	963	Matrix Input 35	MULTFUNC_8BIT_4: DLY_CNT_OUT
	964	Matrix Input 36	MULTFUNC_8BIT_5: DLY_CNT_OUT
	965	Matrix Input 37	MULTFUNC_8BIT_6: DLY_CNT_OUT
	966	Matrix Input 38	MULTFUNC_8BIT_7: DLY_CNT_OUT
	967	Matrix Input 39	MULTFUNC_16BIT_0: LUT_DFF_OUT

SLG46827-A

Auto AEC-Q100 Qualified GreenPAK Programmable Mixed-Signal Matrix with In-System Debug

Table 58: Register Map (Continued)

Address		Signal Function	Register Bit Definition
Byte	Register Bit		
79	968	Matrix Input 40	MULTFUNC_8BIT_1: LUT_DFF_OUT
	969	Matrix Input 41	MULTFUNC_8BIT_2: LUT_DFF_OUT
	970	Matrix Input 42	MULTFUNC_8BIT_3: LUT_DFF_OUT
	971	Matrix Input 43	MULTFUNC_8BIT_4: LUT_DFF_OUT
	972	Matrix Input 44	MULTFUNC_8BIT_5: LUT_DFF_OUT
	973	Matrix Input 45	MULTFUNC_8BIT_6: LUT_DFF_OUT
	974	Matrix Input 46	MULTFUNC_8BIT_7: LUT_DFF_OUT
	975	Matrix Input 47	MULTFUNC_16BIT_0: DLY_CNT_OUT
7A	976	Matrix Input 48	Virtual Input [7]: register [976]
	977	Matrix Input 49	Virtual Input [6]: register [977]
	978	Matrix Input 50	Virtual Input [5]: register [978]
	979	Matrix Input 51	Virtual Input [4]: register [979]
	980	Matrix Input 52	Virtual Input [3]: register [980]
	981	Matrix Input 53	Virtual Input [2]: register [981]
	982	Matrix Input 54	Virtual Input [1]: register [982]
	983	Matrix Input 55	Virtual Input [0]: register [983]
7B	984	Matrix Input 56	ACMP0H OUT
	985	Matrix Input 57	ACMP1H OUT
	986	Matrix Input 58	ACMP2L OUT
	987	Matrix Input 59	ACMP3L OUT
	988	Matrix Input 60	2nd CKOSC1_MATRIX
	989	Matrix Input 61	2nd CKOSC0_MATRIX
	990	Matrix Input 62	POR CORE
	991	Matrix Input 63	Tie high
7C	999:992	CNT0(16-bit) Counted Value	Q[7:0]
7D	1007:1000	CNT0(16-bit) Counted Value	Q[15:8]
7E	1015:1008	CNT2(8-bit) Counted Value	Q[7:0]
7F	1023:1016	CNT4(8-bit) Counted Value	Q[7:0]
OSC/ACMP			

SLG46827-A

Auto AEC-Q100 Qualified GreenPAK Programmable Mixed-Signal Matrix with In-System Debug

Table 58: Register Map (Continued)

Address		Signal Function	Register Bit Definition
Byte	Register Bit		
80	1024	OSC1 turn on by register	when matrix output enable/pd control signal = 0: 0: auto on by delay cells 1: always on
	1025	matrix power-down or on select	0: matrix down 1: matrix on
	1026	external clock source enable	0: internal OSC1 1: external clock from IO10
	1028:1027	post divider ration control	00: div1 01: div2 10: div4 11: div8
	1031:1029	matrix divider ratio control	000: /1 001: /2 010: /4 011: /3 100: /8 101: /12 110: /24 111: /64
81	1032	OSC2 turn on by register	when matrix output enable/pd control signal = 0: 0: auto on by delay cells 1: always on
	1033	matrix power-down or on select	0: matrix down 1: matrix on
	1034	external clock source enable	0: internal OSC2 1: external clock from IO8
	1036:1035	post divider ration control	00: div1 01: div2 10: div4 11: div8
	1039:1037	matrix divider ratio control	000: /1 001: /2 010: /4 011: /3 100: /8 101: /12 110: /24 111: /64

SLG46827-A

Auto AEC-Q100 Qualified GreenPAK Programmable Mixed-Signal Matrix with In-System Debug

Table 58: Register Map (Continued)

Address		Signal Function	Register Bit Definition
Byte	Register Bit		
82	1040	OSC0 turn on by register	when matrix output enable/pd control signal = 0: 0: auto on by delay cells 1: always on
	1041	matrix power-down or on select	0: matrix down 1: matrix on
	1042	external clock source enable	0: internal OSC0 1: external clock from IO0
	1044:1043	post divider ration control	00: div1 01: div2 10: div4 11: div8
	1047:1045	matrix divider ratio control	000: /1 001: /2 010: /4 011: /3 100: /8 101: /12 110: /24 111: /64
83	1048	Reserved	
	1049	OSC0 matrix out enable	0: disable 1: enable
	1050	OSC1 matrix out enable	0: disable 1: enable
	1051	OSC2 matrix out enable	0: disable 1: enable
	1052	OSC2 100 ns Startup Delay	0: enable 1: disable
	1053	OSC0 2nd matrix out enable	0: disable 1: enable
	1054	OSC1 2nd matrix out enable	0: disable 1: enable
	1055	Reserved	
84	1058:1056	OSC1 2nd matrix input: matrix divider ratio control	000: /1 001: /2 010: /4 011: /3 100: /8 101: /12 110: /24 111: /64
	1061:1059	OSC0 2nd matrix input: matrix divider ratio control	000: /1 001: /2 010: /4 011: /3 100: /8 101: /12 110: /24 111: /64
	1063:1062	Reserved	

SLG46827-A

Auto AEC-Q100 Qualified GreenPAK Programmable Mixed-Signal Matrix with In-System Debug

Table 58: Register Map (Continued)

Address		Signal Function	Register Bit Definition
Byte	Register Bit		
85	1065:1064	ACMP0H hysteresis	00: 0 mV 01: 32 mV 10: 64 mV 11: 192 mV
	1066	Reserved	0: disable 1: enable
	1067	ACMP0H input buffer enable	0: disable 1: enable
	1068	Reserved	0: disable 1: enable
	1069	ACMP0H input tie to V _{DD} enable	0: disable 1: enable
	1070	ACMP0H wake/sleep enable	0: disable 1: enable
	1071	ACMP0H 100 uA current source enable	0: disable 1: enable
86	1072	ACMP1H positive input come from ACMP0H's input mux output enable	0: disable 1: enable
	1073	Reserved	0: disable 1: enable
	1075:1074	ACMP1H hysteresis	00: 0 mV 01: 32 mV 10: 64 mV 11: 192 mV
	1076	ACMP1H input buffer enable	0: disable 1: enable
	1077	Reserved	0: disable 1: enable
	1078	ACMP1H wake/sleep enable	0: disable 1: enable
	1079	ACMP wake/sleep time selection	0: short time wake/sleep 1: normal time wake/sleep
87	1080	ACMP2L positive input come from ACMP0H's input mux output enable	0: disable 1: enable
	1081	ACMP2L positive input come from ACMP1H's input mux output enable	0: disable 1: enable
	1083:1082	ACMP2L hysteresis	00: 0 mV 01: 32 mV 10: 64 mV 11: 192 mV
	1084	Reserved	0: disable 1: enable
	1085	Reserved	0: disable 1: enable
	1086	Reserved	
	1087	ACMP0H, ACMP1H input buffer WS enable	0: disable 1: enable

SLG46827-A

Auto AEC-Q100 Qualified GreenPAK Programmable Mixed-Signal Matrix with In-System Debug

Table 58: Register Map (Continued)

Address		Signal Function	Register Bit Definition
Byte	Register Bit		
88	1089:1088	ACMP3L hysteresis	00: 0 mV 01: 32 mV 10: 64 mV 11: 192 mV
	1090	Reserved	0: disable 1: enable
	1091	Reserved	0: disable 1: enable
	1092	ACMP3L positive input come from ACMP2L's input mux output enable	0: disable 1: enable
	1093	Temp sensor register pd control	0: power-down 1: power-on
	1094	Temp sensor register pd select	0: come from register 1: come from matrix
	1095	Temp sensor range select	0: range 1 (0.62 V to 0.99 V typical) 1: range 2 (0.75 V to 1.2 V typical)
89	1097:1096	ACMP0H Gain divider	00: 1x 01: 0.5x 10: 0.33x 11: 0.25x
	1103:1098	ACMP0H Vref	ACMP Vref select: 000000: 32 mV ~ 111110: 2.016 V/step = 32 mV; 111111: External Vref
8A	1105:1104	ACMP1H Gain divider	00: 1x 01: 0.5x 10: 0.33x 11: 0.25x
	1111:1106	ACMP1H Vref	ACMP Vref select: 000000: 32 mV ~ 111110: 2.016 V/step = 32 mV; 111111: External Vref
8B	1113:1112	ACMP2L Gain divider	00: 1x 01: 0.5x 10: 0.33x 11: 0.25x
	1119:1114	ACMP2L Vref	ACMP Vref select: 000000: 32 mV ~ 111110: 2.016 V/step = 32 mV; 111111: External Vref
8C	1121:1120	ACMP3L Gain divider	00: 1x 01: 0.5x 10: 0.33x 11: 0.25x
	1127:1122	ACMP3L Vref	ACMP Vref select: 000000: 32 mV ~ 111110: 2.016 V/step = 32 mV; 111111: External Vref

SLG46827-A

Auto AEC-Q100 Qualified GreenPAK Programmable Mixed-Signal Matrix with In-System Debug

Table 58: Register Map (Continued)

Address		Signal Function	Register Bit Definition
Byte	Register Bit		
8D	1128	Vref_OUT0 output OP	0: disable 1: enable
	1130:1129	Vref_OUT0 input selection	00: None 01: ACMP0H Vref 10: ACMP1H Vref 11: temp sensor
	1131	Vref_OUT1 output OP	0: disable 1: enable
	1133:1132	Vref_OUT1 input selection	00: None 01: ACMP2L Vref 10: ACMP3L Vref 11: Reserved
	1134	Reserved	
	1135	Tempsensed voltage to ACMP	0: disable connection from temp sensed voltage (Vref00) to ACMP3L input 1: enable connection from temp sensed voltage (Vref00) to ACMP3L input
8E	1136	Reserved	
	1137	Vref_OUT0 PD	0: Vref_OUT0 disable 1: Vref_OUT0 enable
	1138	Vref_OUT0 PD selection	0: enable/disable using Vref_OUT0 PD [1137] 1: enable/disable using matrix out[60] TS_OSC_PD
	1139	Vref_OUT1 PD	0: Vref_OUT1 disable 1: Vref_OUT1 enable
	1140	Vref_OUT1 PD selection	0: enable/disable using Vref_OUT1 PD [1139] 1: enable/disable using matrix out[60] TS_OSC_pd
	1143:1141	Reserved	
8F	1145:1144	Reserved	
	1151:1146	Reserved	
Digital Macrocell			
90	1155:1152	LUT2_0/DFF0 setting	[3]: LUT2_0[3]/DFF0 or LATCH Select 0: DFF function 1: LATCH function [2]: LUT2_0[2]/DFF0 Output Sel 0: Q output 1: QB output [1]: LUT2_0[1]/DFF0 Initial Polarity Select 0: Low 1: High [0]: LUT2_0[0]
	1159:1156	LUT2_1/DFF1 setting	[3]: LUT2_1[3]/DFF1 or LATCH Select 0: DFF function 1: LATCH function [2]: LUT2_1[2]/DFF1 Output Select 0: Q output 1: QB output [1]: LUT2_1[1]/DFF1 Initial Polarity Select 0: Low 1: High [0]: LUT2_1[0]

SLG46827-A

Auto AEC-Q100 Qualified GreenPAK Programmable Mixed-Signal Matrix with In-System Debug

Table 58: Register Map (Continued)

Address		Signal Function	Register Bit Definition
Byte	Register Bit		
91	1163:1160	LUT2_2/DFF2 setting	[3]: LUT2_2[3]/DFF2 or LATCH Select 0: DFF function 1: LATCH function [2]: LUT2_2[2]/DFF2 Output Select 0: Q output 1: QB output [1]: LUT2_2[1]/DFF2 Initial Polarity Select 0: Low 1: High [0]: LUT2_2[0]
	1167:1164	LUT2_3_VAL or PGEN_data	LUT2_3[3:0] or PGen 4bit counter data[3:0]
92	1175:1168	PGen data [7:0]	PGen data [7:0]
93	1183:1176	PGen data [15:8]	PGen data [15:8]
94	1191:1184	LUT3_0_DFF3 setting	[7]: LUT3_0[7]/DFF3 or LATCH Select 0: DFF function 1: LATCH function [6]: LUT3_0[6]/DFF3 Output Select 0: Q output 1: QB output [5]: LUT3_0[5]/DFF3 0: nRST from Matrix Output 1: nSET from Matrix Output [4]: LUT3_0[4]/DFF3 Initial Polarity Select 0: Low 1: High [3:0]: LUT3_0[3:0]
			[7]: LUT3_1[7]/DFF4 or LATCH Select 0: DFF function 1: LATCH function [6]: LUT3_1[6]/DFF4 Output Select 0: Q output 1: QB output [5]: LUT3_1[5]/DFF4 0: nRST from Matrix Output 1: nSET from Matrix Output [4]: LUT3_1[4]/DFF4 Initial Polarity Select 0: Low 1: High [3:0]: LUT3_1[3:0]
95	1199:1192	LUT3_1_DFF4 setting	[7]: LUT3_2[7]/DFF5 or LATCH Select 0: DFF function 1: LATCH function [6]: LUT3_2[6]/DFF5 Output Select 0: Q output 1: QB output [5]: LUT3_2[5]/DFF5 0: nRST from Matrix Output 1: nSET from Matrix Output [4]: LUT3_2[4]/DFF5 Initial Polarity Select 0: Low 1: High [3:0]: LUT3_2[3:0]
96	1207:1200	LUT3_2_DFF5 setting	[7]: LUT3_2[7]/DFF5 or LATCH Select 0: DFF function 1: LATCH function [6]: LUT3_2[6]/DFF5 Output Select 0: Q output 1: QB output [5]: LUT3_2[5]/DFF5 0: nRST from Matrix Output 1: nSET from Matrix Output [4]: LUT3_2[4]/DFF5 Initial Polarity Select 0: Low 1: High [3:0]: LUT3_2[3:0]

SLG46827-A

Auto AEC-Q100 Qualified GreenPAK Programmable Mixed-Signal Matrix with In-System Debug

Table 58: Register Map (Continued)

Address		Signal Function	Register Bit Definition
Byte	Register Bit		
97	1215:1208	LUT3_3_DFF6 setting	[7]: LUT3_3[7]/DFF6 or LATCH Select 0: DFF function 1: LATCH function [6]: LUT3_3[6]/DFF6 Output Select 0: Q output 1: QB output [5]: LUT3_3[5]/DFF6 0: nRST from Matrix Output 1: nSET from Matrix Output [4]: LUT3_3[4]/DFF6 Initial Polarity Select 0: Low 1: High [3:0]: LUT3_3[3:0]
98	1223:1216	LUT3_4_DFF7 setting	[7]: LUT3_4[7]/DFF7 or LATCH Select 0: DFF function 1: LATCH function [6]: LUT3_4[6]/DFF7 Output Select 0: Q output 1: QB output [5]: LUT3_4[5]/DFF7 0: nRST from Matrix Output 1: nSET from Matrix Output [4]: LUT3_4[4]/DFF7 Initial Polarity Select 0: Low 1: High [3:0]: LUT3_4[3:0]
99	1231:1224	LUT3_5_DFF8 setting	[7]: LUT3_5[7]/DFF8 or LATCH Select 0: DFF function 1: LATCH function [6]: LUT3_5[6]/DFF8 Output Select 0: Q output 1: QB output [5]: LUT3_5[5]/DFF8 0: RSTB from Matrix Output 1: SETB from Matrix Output [4]: LUT3_5[4]/DFF8 Initial Polarity Select 0: Low 1: High [3:0]: LUT3_5[3:0]

SLG46827-A

Auto AEC-Q100 Qualified GreenPAK Programmable Mixed-Signal Matrix with In-System Debug

Table 58: Register Map (Continued)

Address		Signal Function	Register Bit Definition
Byte	Register Bit		
9A	1232	LUT2_0 or DFF0 Select	0: LUT2_0 1: DFF0
	1233	LUT2_1 or DFF1 Select	0: LUT2_1 1: DFF1
	1234	LUT2_2 or DFF2 Select	0: LUT2_2 1: DFF2
	1235	LUT2_3 or PGen Select	0: LUT2_3 1: PGen
	1236	LUT3_0 or DFF3 Select	0: LUT3_0 1: DFF3
	1237	DFF3_SECONDQ_Sel	0: Q of first DFF 1: Q of second DFF
	1238	LUT3_1 or DFF4 Select	0: LUT3_1 1: DFF4
	1239	LUT3_2 or DFF5 Select	0: LUT3_2 1: DFF5
9B	1240	LUT3_3 or DFF6 Select	0: LUT3_3 1: DFF6
	1241	LUT3_4 or DFF7 Select	0: LUT3_4 1: DFF7
	1242	LUT3_5 or DFF8 Select	0: LUT3_5 1: DFF8
	1243	Filter or Edge Detector selection	0: filter 1: edge det
	1244	output Polarity Select	0: Filter/edge detect output 1: Filter/edge detect output inverted
	1246:1245	Select the edge mode	00: Rising Edge Det 01: Falling Edge Det 10: Both Edge Det 11: Both Edge DLY
	1247	Reserved	
9C	1255:1248	LUT value or Pipe Delay out SEL or nSET/END value	[7:4]:LUT3_6[7:4]/REG_S1[3:0]Pipe Delay out1 SEL [3:0]:LUT3_6[3:0]/REG_S0[3:0]Pipe Delay out0 SEL at RIPP CNT mode: bit[1250:1248] is the nSET value bit[1253:1251] is the END value bit[1254] functional mode:0: full cycle; 1: ranged cycle bit[1255] not used

SLG46827-A

Auto AEC-Q100 Qualified GreenPAK Programmable Mixed-Signal Matrix with In-System Debug

Table 58: Register Map (Continued)

Address		Signal Function	Register Bit Definition
Byte	Register Bit		
9D	1256	Pipe Delay OUT1 Polarity Select	0: Non-inverted 1: Inverted
	1257	LUT3_6 or Pipe Delay Select	0: LUT3_6 1: Pipe Delay or RIPP CNT
	1258	PIPE_RIPP_CNT_S	0: Pipe delay mode selection 1: Ripple Counter mode selection
	1260:1259	Select the Edge Mode of Programmable Delay & Edge Detector	00: Rising Edge Detector 01: Falling Edge Detector 10: Both Edge Detector 11: Both Edge Delay
	1262:1261	Delay Value Select for Programmable Delay & Edge Detector	00: 125ns 01: 250ns 10: 375ns 11: 500ns
	1263	Reserved	
9E	1264	Reserved	
	1265	Reserved	
	1266	Reserved	
	1271:1267	Reserved	
9F	1276:1272	Reserved	
	1277	Reserved	
	1278	Reserved	
	1279	Reserved	
Multifunction			
A0	1286 1285 1282 1284 1283 1281 1280	Single 4-bit LUT	0000000: Matrix A - In3; Matrix B - In2; Matrix C - In1; Matrix D - In0 (DLY_IN - LOW)
		Single DFF w RST and SET	0010000: Matrix A - D; Matrix B - nSET; Matrix C - nRST; Matrix D - CLK (DLY_IN - LOW)
		Single CNT/DLY	0000001: Matrix A - UP (CNT); Matrix B - KEEP (CNT); Matrix C - EXT_CLK (CNT); Matrix D - DLY_IN (CNT) (DLY_OUT connected to LUT/DFF)
		CNT/DLY → LUT	0000010: Matrix A - DLY_IN; Matrix B - In2; Matrix C - In1; Matrix D - In0 (DLY_OUT connected to In3)

SLG46827-A

Auto AEC-Q100 Qualified GreenPAK Programmable Mixed-Signal Matrix with In-System Debug

Table 58: Register Map (Continued)

Address		Signal Function	Register Bit Definition
Byte	Register Bit		
A0	1286 1285 1282 1284 1283 1281 1280	CNT/DLY → DFF	0000110: Matrix A - DLY_IN; Matrix B - nSET; Matrix C - nRST; Matrix D - CLK (DLY_OUT connected to D)
		CNT/DLY → LUT	0100010: Matrix A - DLY_IN; Matrix B - EXT_CLK (CNT); Matrix C - In1; Matrix D - In0 (DLY_OUT connected to In3; In2 - LOW)
		CNT/DLY → DFF	0100110: Matrix A - DLY_IN; Matrix B - EXT_CLK (CNT); Matrix C - nRST; Matrix D - CLK (DLY_OUT connected to D; nSET - HIGH)
		CNT/DLY → LUT	1000010: Matrix A - DLY_IN; Matrix B - In2; Matrix C - EXT_CLK (CNT); Matrix D - In0 (DLY_OUT connected to In3; In1 - LOW)
		CNT/DLY → DFF	1000110: Matrix A - DLY_IN; Matrix B - nSET; Matrix C - EXT_CLK (CNT); Matrix D - CLK (DLY_OUT connected to D; nRST - HIGH)
		CNT/DLY → LUT	0001010: Matrix A - In3; Matrix B - DLY_IN; Matrix C - In1; Matrix D - In0 (DLY_OUT connected to In2)
		CNT/DLY → DFF	0001110: Matrix A - D; Matrix B - DLY_IN; Matrix C - nRST; Matrix D - CLK (DLY_OUT connected to nSET)
		CNT/DLY → LUT	1001010: Matrix A - In3; Matrix B - DLY_IN; Matrix C - EXT_CLK (CNT); Matrix D - In0 (DLY_OUT connected to In2; In1 - LOW)
		CNT/DLY → DFF	1001110: Matrix A - D; Matrix B - DLY_IN; Matrix C - EXT_CLK (CNT); Matrix D - CLK (DLY_OUT connected to nSET; nRST - HIGH)
		CNT/DLY → LUT	0010010: Matrix A - In3; Matrix B - In2; Matrix C - DLY_IN; Matrix D - In0 (DLY_OUT connected to In1)
		CNT/DLY → DFF	0010110: Matrix A - D; Matrix B - nSET; Matrix C - DLY_IN; Matrix D - CLK (DLY_OUT connected to nRST)
		CNT/DLY → LUT	0110010: Matrix A - In3; Matrix B - EXT_CLK (CNT); Matrix C - DLY_IN; Matrix D - In0 (DLY_OUT connected to In1; In2 - LOW)
		CNT/DLY → DFF	0110110: Matrix A - D; Matrix B - EXT_CLK (CNT); Matrix C - DLY_IN; Matrix D - CLK (DLY_OUT connected to nRST; nSET - HIGH)
		CNT/DLY → LUT	0011010: Matrix A - In3; Matrix B - In2; Matrix C - In1; Matrix D - DLY_IN (DLY_OUT connected to In0)

SLG46827-A

Auto AEC-Q100 Qualified GreenPAK Programmable Mixed-Signal Matrix with In-System Debug

Table 58: Register Map (Continued)

Address		Signal Function	Register Bit Definition
Byte	Register Bit		
A0	1286 1285 1282 1284 1283 1281 1280	CNT/DLY → DFF	0011110: Matrix A - D; Matrix B - nSET; Matrix C - nRST; Matrix D - DLY_IN (DLY_OUT connected to CLK)
		CNT/DLY → LUT	0111010: Matrix A - In3; Matrix B - EXT_CLK (CNT); Matrix C - In1; Matrix D - DLY_IN (DLY_OUT connected to In0; In2 - LOW)
		CNT/DLY → DFF	0111110: Matrix A - D; Matrix B - EXT_CLK (CNT); Matrix C - nRST; Matrix D - DLY_IN (DLY_OUT connected to CLK; nSET - HIGH)
		CNT/DLY → LUT	1011010: Matrix A - In3; Matrix B - In2; Matrix C - EXT_CLK (CNT); Matrix D - DLY_IN (DLY_OUT connected to In0; In1 - LOW)
		CNT/DLY → DFF	1011110: Matrix A - D; Matrix B - nSET; Matrix C - EXT_CLK (CNT); Matrix D - DLY_IN (DLY_OUT connected to CLK; nRST - HIGH)
		LUT → CNT/DLY	0000011: Matrix A - In3; Matrix B - In2; Matrix C - In1; Matrix D - In0 (LUT_OUT connected to DLY_IN)
		DFF → CNT/DLY	0000111: Matrix A - D; Matrix B - nSET; Matrix C - nRST; Matrix D - CLK (DFF_OUT connected to DLY_IN)
		LUT → CNT/DLY	0100011: Matrix A - In3; Matrix B - EXT_CLK (CNT); Matrix C - In1; Matrix D - In0 (LUT_OUT connected to DLY_IN; In2 - LOW)
		DFF → CNT/DLY	0100111: Matrix A - D; Matrix B - EXT_CLK (CNT); Matrix C - nRST; Matrix D - CLK (DFF_OUT connected to DLY_IN; nSET - HIGH)
		LUT → CNT/DLY	1000011: Matrix A - In3; Matrix B - In2; Matrix C - EXT_CLK (CNT); Matrix D - In0 (LUT_OUT connected to DLY_IN; In1 - LOW)
	DFF → CNT/DLY	1000111: Matrix A - D; Matrix B - nSET; Matrix C - EXT_CLK (CNT); Matrix D - CLK (DFF_OUT connected to DLY_IN; nRST - HIGH)	
	1287	FSM0 SET/RST Selection	0: Reset to 0 1: Set to data
A1	1295:1288	LUT4_0_DFF9 setting [7:0]	[7:0]: LUT4_0[7:0]
A2	1303:1296	LUT4_0_DFF9 setting [15:8]	[15]: LUT4_0[15]/DFF or LATCH Select 0: DFF function; 1: LATCH function [14]: LUT4_0[14]/DFF Output Select 0: Q output; 1: QB output [13]: LUT4_0[13]/DFF Initial Polarity Select 0: Low; 1: High [12:8]: LUT4_0[12:8]

SLG46827-A

Auto AEC-Q100 Qualified GreenPAK Programmable Mixed-Signal Matrix with In-System Debug

Table 58: Register Map (Continued)

Address		Signal Function	Register Bit Definition
Byte	Register Bit		
A3	1305:1304	DLY/CNT0 Mode Selection	00: DLY 01: one shot 10: frequency det 11: CNT
	1307:1306	DLY/CNT0 edge Mode Selection	00: both edge 01: falling edge 10: rising edge 11: High Level Reset (only in CNT mode)
	1311:1308	DLY/CNT0 Clock Source Select	Clock source SEL [3:0] 0000: 25M(OSC2); 0001: 25M/4; 0010: 2M(OSC1); 0011: 2M/8; 0100: 2M/64; 0101: 2M/512; 0110: 2K(OSC0); 0111: 2K/8; 1000: 2K/64; 1001: 2K/512; 1010: 2K/4096; 1011: 2K/32768; 1100: 2K/262144; 1101: CNT_END; 1110: External; 1111: Not used
A4	1312	CNT0 output pol selection	0: Default Output 1: Inverted Output
	1314:1313	CNT0 initial value selection	00: bypass the initial 01: initial 0 10: initial 1 11: initial 1
	1315	Wake sleep power-down state selection	0: low 1: high
	1316	Wake sleep mode selection	0: disable wake/sleep mode 1: enable wake/sleep mode
	1317	Keep signal SYNC selection	0: bypass 1: after two DFF
	1318	UP signal SYNC selection	0: bypass 1: after two DFF
	1319	CNT0 DLY EDET FUNCTION Selection	0: normal 1: DLY function edge detection
A5	1327:1320	REG_CNT0_Data[7:0]	Data[7:0]
A6	1335:1328	REG_CNT0_Data[15:8]	Data[15:8]
A7	1336	CNT0 CNT mode SYNC selection	0: bypass 1: after two DFF
	1339 1341 1340	Single 3-bit LUT	00000: Matrix A - In2; Matrix B - In1; Matrix C - In0 (DLY_IN - LOW)
	1338 1337	Single DFF w RST and SET	10000: Matrix A - D; Matrix B - nSET/nRST; Matrix C - CLK (DLY_IN - LOW)

SLG46827-A

Auto AEC-Q100 Qualified GreenPAK Programmable Mixed-Signal Matrix with In-System Debug

Table 58: Register Map (Continued)

Address		Signal Function	Register Bit Definition
Byte	Register Bit		
A7	1339 1341 1340 1338 1337	Single CNT/DLY	00001: Matrix A - DLY_IN (CNT); Matrix B - EXT_CLK (CNT); Matrix C - NC (DLY_OUT connected to LUT/DFF)
		CNT/DLY → LUT	00010: Matrix A - DLY_IN; Matrix B - In1; Matrix C - In0 (DLY_OUT connected to In2)
		CNT/DLY → DFF	00110: Matrix A - DLY_IN; Matrix B - nSET/nRST; Matrix C - CLK (DLY_OUT connected to D)
		CNT/DLY → LUT	01010: Matrix A - In2; Matrix B - DLY_IN; Matrix C - In0 (DLY_OUT connected to In1)
		CNT/DLY → DFF	01110: Matrix A - D; Matrix B - DLY_IN; Matrix C - CLK (DLY_OUT connected to nSET/nRST)
		CNT/DLY → LUT	10010: Matrix A - In2; Matrix B - In1; Matrix C - DLY_IN (DLY_OUT connected to In0)
		CNT/DLY → DFF	11010: Matrix A - D; Matrix B - nSET/nRST; Matrix C - DLY_IN (DLY_OUT connected to CLK)
		LUT → CNT/DLY	00011: Matrix A - In2; Matrix B - In1; Matrix C - In0 (LUT_OUT connected to DLY_IN)
	DFF → CNT/DLY	00111: Matrix A - D; Matrix B - nSET/nRST; Matrix C - CLK (DFF_OUT connected to DLY_IN)	
	1343:1342	CNT1 initial value selection	00: bypass the initial 01: initial 0 10: initial 1 11: initial 1
A8	1351:1344	LUT3_7_DFF10 setting	[7]: LUT3_7[7]/DFF or LATCH Select 0: DFF function; 1: LATCH function [6]: LUT3_7[6]/DFF Output Select 0: Q output; 1: QB output [5]: LUT3_7[5]/DFF 0: nRST from Matrix Output; 1: nSET from Matrix Output [4]: LUT3_7[4]/DFF Initial Polarity Select 0:Low; 1: High [3:0]: LUT3_7[3:0]
A9	1355:1352	DLY/CNT1 Clock Source Select	Clock source SEL [3:0] 0000: 25M(OSC2); 0001: 25M/4; 0010: 2M(OSC1); 0011: 2M/8; 0100: 2M/64; 0101: 2M/512; 0110: 2K(OSC0); 0111: 2K/8; 1000: 2K/64; 1001: 2K/512; 1010: 2K/4096; 1011: 2K/32768; 1100: 2K/262144; 1101: CNT_END; 1110: External; 1111: Not used
	1359:1356	CNT1 function and edge mode selection	0000: both edge Delay; 0001: falling edge delay; 0010: rising edge delay; 0011: both edge One Shot; 0100: falling edge One Shot; 0101: rising edge One Shot; 0110: both edge freq detect; 0111: falling edge freq detect; 1000: rising edge freq detect; 1001: both edge detect; 1010: falling edge detect; 1011: rising edge detect; 1100: both edge reset CNT; 1101: falling edge reset CNT; 1110: rising edge reset CNT; 1111: high level reset CNT
AA	1367:1360	REG_CNT1_Data[7:0]	Data[7:0]

SLG46827-A

Auto AEC-Q100 Qualified GreenPAK Programmable Mixed-Signal Matrix with In-System Debug

Table 58: Register Map (Continued)

Address		Signal Function	Register Bit Definition
Byte	Register Bit		
AB	1368	CNT1 output pol selection	0: Default Output 1: Inverted Output
	1369	Reserved	
	1370	CNT1 CNT mode SYNC selection	0: bypass 1: after two DFF
	1371	CNT1 DLY EDET FUNCTION Selection	0: normal 1: DLY function edge detection
	1394, 1375:1372	Single 3-bit LUT	00000: Matrix A - In2; Matrix B - In1; Matrix C - In0 (DLY_IN - LOW)
	Single DFF w RST and SET	10000: Matrix A - D; Matrix B - nSET/nRST; Matrix C - CLK (DLY_IN - LOW)	
AB	1394, 1375:1372	Single CNT/DLY	00001: Matrix A - DLY_IN (CNT); Matrix B - EXT_CLK (CNT); Matrix C - NC (DLY_OUT connected to LUT/DFF)
		CNT/DLY → LUT	00010: Matrix A - DLY_IN; Matrix B - In1; Matrix C - In0 (DLY_OUT connected to In2)
		CNT/DLY → DFF	10010: Matrix A - DLY_IN; Matrix B - nSET/nRST; Matrix C - CLK (DLY_OUT connected to D)
		CNT/DLY → LUT	00110: Matrix A - In2; Matrix B - DLY_IN; Matrix C - In0 (DLY_OUT connected to In1)
		CNT/DLY → DFF	10110: Matrix A - D; Matrix B - DLY_IN; Matrix C - CLK (DLY_OUT connected to nSET/nRST)
		CNT/DLY → LUT	01010: Matrix A - In2; Matrix B - In1; Matrix C - DLY_IN (DLY_OUT connected to In0)
		CNT/DLY → DFF	11010: Matrix A - D; Matrix B - nSET/nRST; Matrix C - DLY_IN (DLY_OUT connected to CLK)
		LUT → CNT/DLY	00011: Matrix A - In2; Matrix B - In1; Matrix C - In0 (LUT_OUT connected to DLY_IN)
		DFF → CNT/DLY	10011: Matrix A - D; Matrix B - nSET/nRST; Matrix C - CLK (DFF_OUT connected to DLY_IN)
AC	1383:1376	LUT3_8_DFF_11 setting	[7]: LUT3_8[7]/DFF or LATCH Select 0: DFF function; 1: LATCH function [6]: LUT3_8[6]/DFF Output Select 0: Q output; 1: QB output [5]: LUT3_8[5]/DFF 0: nRST from Matrix Output; 1: nSET from Matrix Output [4]: LUT3_8[4]/DFF Initial Polarity Select 0: Low; 1: High [3:0]: LUT3_8[3:0]

SLG46827-A

Auto AEC-Q100 Qualified GreenPAK Programmable Mixed-Signal Matrix with In-System Debug

Table 58: Register Map (Continued)

Address		Signal Function	Register Bit Definition
Byte	Register Bit		
AD	1387:1384	DLY/CNT2 Clock Source Select	Clock source SEL [3:0] 0000: 25M(OSC2); 0001: 25M/4; 0010: 2M(OSC1); 0011: 2M/8; 0100: 2M/64; 0101: 2M/512; 0110: 2K(OSC0); 0111: 2K/8; 1000: 2K/64; 1001: 2K/512; 1010: 2K/4096; 1011: 2K/32768; 1100: 2K/262144; 1101: CNT_END; 1110: External; 1111: Not used
	1391:1388	CNT2 function and edge mode selection	0000: both edge Delay; 0001: falling edge delay; 0010: rising edge delay; 0011: both edge One Shot; 0100: falling edge One Shot; 0101: rising edge One Shot; 0110: both edge freq detect; 0111: falling edge freq detect; 1000: rising edge freq detect; 1001: both edge detect; 1010: falling edge detect; 1011: rising edge detect; 1100: both edge reset CNT; 1101: falling edge reset CNT; 1110: rising edge reset CNT; 1111: high level reset CNT
AE	1393:1392	CNT2 initial value selection	00: bypass the initial 01: initial 0 10: initial 1 11: initial 1
	1395	CNT2 output pol selection	0: Default Output 1: Inverted Output
	1396	Reserved	
	1397	CNT2 CNT mode SYNC selection	0: bypass 1: after two DFF
	1398	CNT2 DLY EDET FUNCTION Selection	0: normal 1: DLY function edge detection
	1399	Reserved	
AF	1407:1400	REG_CNT2_Data[7:0]	Data[7:0]
B0	1408	Reserved	
	1411 1413 1412	Single 3-bit LUT	00000: Matrix A - In2; Matrix B - In1; Matrix C - In0 (DLY_IN - LOW)
	1410 1409	Single DFF w RST and SET	00100: Matrix A - D; Matrix B - nSET/nRST; Matrix C - CLK (DLY_IN - LOW)

SLG46827-A

Auto AEC-Q100 Qualified GreenPAK Programmable Mixed-Signal Matrix with In-System Debug

Table 58: Register Map (Continued)

Address		Signal Function	Register Bit Definition
Byte	Register Bit		
B0	1411 1413 1412 1410 1409	Single CNT/DLY	00001: Matrix A - DLY_IN (CNT); Matrix B - EXT_CLK (CNT); Matrix C - NC (DLY_OUT connected to LUT/DFF)
		CNT/DLY → LUT	00010: Matrix A - DLY_IN; Matrix B - In1; Matrix C - In0 (DLY_OUT connected to In2)
		CNT/DLY → DFF	00110: Matrix A - DLY_IN; Matrix B - nSET/nRST; Matrix C - CLK (DLY_OUT connected to D)
		CNT/DLY → LUT	01010: Matrix A - In2; Matrix B - DLY_IN; Matrix C - In0 (DLY_OUT connected to In1)
		CNT/DLY → DFF	01110: Matrix A - D; Matrix B - DLY_IN; Matrix C - CLK (DLY_OUT connected to nSET/nRST)
		CNT/DLY → LUT	10010: Matrix A - In2; Matrix B - In1; Matrix C - DLY_IN (DLY_OUT connected to In0)
		CNT/DLY → DFF	10110: Matrix A - D; Matrix B - nSET/nRST; Matrix C - DLY_IN (DLY_OUT connected to CLK)
		LUT → CNT/DLY	00011: Matrix A - In2; Matrix B - In1; Matrix C - In0 (LUT_OUT connected to DLY_IN)
		DFF → CNT/DLY	00111: Matrix A - D; Matrix B - nSET/nRST; Matrix C - CLK (DFF_OUT connected to DLY_IN)
	1415:1414	CNT3 initial value selection	00: bypass the initial 01: initial 0 10: initial 1 11: initial 1
B1	1423:1416	LUT3_9_DFF12 setting	[7]: LUT3_9[7]/DFF or LATCH Select 0: DFF function; 1: LATCH function [6]: LUT3_9[6]/DFF Output Select 0: Q output; 1: QB output [5]: LUT3_9[5]/DFF 0: nRST from Matrix Output; 1: nSET from Matrix Output [4]: LUT3_9[4]/DFF Initial Polarity Select 0:Low; 1: High [3:0]: LUT3_9[3:0]
B2	1427:1424	DLY/CNT3 Clock Source Select	Clock source SEL [3:0] 0000: 25M(OSC2); 0001: 25M/4; 0010: 2M(OSC1); 0011: 2M/8; 0100: 2M/64; 0101: 2M/512; 0110: 2K(OSC0); 0111: 2K/8; 1000: 2K/64; 1001: 2K/512; 1010: 2K/4096; 1011: 2K/32768; 1100: 2K/262144; 1101: CNT_END; 1110: External; 1111: Not used
	1431:1428	CNT3 function and edge mode selection	0000: both edge Delay; 0001: falling edge delay; 0010: rising edge delay; 0011: both edge One Shot; 0100: falling edge One Shot; 0101: rising edge One Shot; 0110: both edge freq detect; 0111: falling edge freq detect; 1000: rising edge freq detect; 1001: both edge detect; 1010: falling edge detect; 1011: rising edge detect; 1100: both edge reset CNT; 1101: falling edge reset CNT; 1110: rising edge reset CNT; 1111: high level reset CNT
B3	1439:1432	REG_CNT3_Data[7:0]	Data[7:0]

SLG46827-A

Auto AEC-Q100 Qualified GreenPAK Programmable Mixed-Signal Matrix with In-System Debug

Table 58: Register Map (Continued)

Address		Signal Function	Register Bit Definition
Byte	Register Bit		
B4	1440	CNT3 output pol selection	0: Default Output 1: Inverted Output
	1441	Reserved	
	1442	CNT3 CNT mode SYNC selection	0: bypass 1: after two DFF
	1443	CNT3 DLY EDET FUNCTION Selection	0: normal 1: DLY function edge detection
	1466, 1447:1444	Single 3-bit LUT	00000: Matrix A - In2; Matrix B - In1; Matrix C - In0 (DLY_IN - LOW)
	Single DFF w RST and SET	10000: Matrix A - D; Matrix B - nSET/nRST; Matrix C - CLK (DLY_IN - LOW)	
B4	1466, 1447:1444	Single CNT/DLY	00001: Matrix A - DLY_IN (CNT); Matrix B - EXT_CLK (CNT); Matrix C - NC (DLY_OUT connected to LUT/DFF)
		CNT/DLY → LUT	00010: Matrix A - DLY_IN; Matrix B - In1; Matrix C - In0 (DLY_OUT connected to In2)
		CNT/DLY → DFF	10010: Matrix A - DLY_IN; Matrix B - nSET/nRST; Matrix C - CLK (DLY_OUT connected to D)
		CNT/DLY → LUT	00110: Matrix A - In2; Matrix B - DLY_IN; Matrix C - In0 (DLY_OUT connected to In1)
		CNT/DLY → DFF	10110: Matrix A - D; Matrix B - DLY_IN; Matrix C - CLK (DLY_OUT connected to nSET/nRST)
		CNT/DLY → LUT	01010: Matrix A - In2; Matrix B - In1; Matrix C - DLY_IN (DLY_OUT connected to In0)
		CNT/DLY → DFF	11010: Matrix A - D; Matrix B - nSET/nRST; Matrix C - DLY_IN (DLY_OUT connected to CLK)
		LUT → CNT/DLY	00011: Matrix A - In2; Matrix B - In1; Matrix C - In0 (LUT_OUT connected to DLY_IN)
		DFF → CNT/DLY	10011: Matrix A - D; Matrix B - nSET/nRST; Matrix C - CLK (DFF_OUT connected to DLY_IN)
B5	1455:1448	LUT3_DFF setting	[7]: LUT3[7]/DFF or LATCH Select 0: DFF function; 1: LATCH function [6]: LUT3[6]/DFF Output Select 0: Q output; 1: QB output [5]: LUT3[5]/DFF 0: nRST from Matrix Output; 1: nSET from Matrix Output [4]: LUT3[4]/DFF Initial Polarity Select 0: Low; 1: High [3:0]: LUT3[3:0]

SLG46827-A

Auto AEC-Q100 Qualified GreenPAK Programmable Mixed-Signal Matrix with In-System Debug

Table 58: Register Map (Continued)

Address		Signal Function	Register Bit Definition
Byte	Register Bit		
B6	1459:1456	DLY/CNT4 Clock Source Select	Clock source SEL [3:0] 0000: 25M(OSC2); 0001: 25M/4; 0010: 2M(OSC1); 0011: 2M/8; 0100: 2M/64; 0101: 2M/512; 0110: 2K(OSC0); 0111: 2K/8; 1000: 2K/64; 1001: 2K/512; 1010: 2K/4096; 1011: 2K/32768; 1100: 2K/262144; 1101: CNT_END; 1110: External; 1111: Not used
	1463:1460	CNT4 function and edge mode selection	0000: both edge Delay; 0001: falling edge delay; 0010: rising edge delay; 0011: both edge One Shot; 0100: falling edge One Shot; 0101: rising edge One Shot; 0110: both edge freq detect; 0111: falling edge freq detect; 1000: rising edge freq detect; 1001: both edge detect; 1010: falling edge detect; 1011: rising edge detect; 1100: both edge reset CNT; 1101: falling edge reset CNT; 1110: rising edge reset CNT; 1111: high level reset CNT
B7	1465:1464	CNT4 initial value selection	00: bypass the initial 01: initial 0 10: initial 1 11: initial 1
	1467	CNT4 output pol selection	0: Default Output 1: Inverted Output
	1468	Reserved	
	1469	CNT4 CNT mode SYNC selection	0: bypass 1: after two DFF
	1470	CNT4 DLY EDET FUNCTION Selection	0: normal 1: DLY function edge detection
	1471	Reserved	
B8	1479:1472	REG_CNT4_Data[7:0]	Data[7:0]
B9	1480	Reserved	
	1483 1485 1484	Single 3-bit LUT	00000: Matrix A - In2; Matrix B - In1; Matrix C - In0 (DLY_IN - LOW)
	1482 1481	Single DFF w RST and SET	00100: Matrix A - D; Matrix B - nSET/nRST; Matrix C - CLK (DLY_IN - LOW)

SLG46827-A

Auto AEC-Q100 Qualified GreenPAK Programmable Mixed-Signal Matrix with In-System Debug

Table 58: Register Map (Continued)

Address		Signal Function	Register Bit Definition
Byte	Register Bit		
B9	1483 1485 1484 1482 1481	Single CNT/DLY	00001: Matrix A - DLY_IN (CNT); Matrix B - EXT_CLK (CNT); Matrix C - NC (DLY_OUT connected to LUT/DFF)
		CNT/DLY → LUT	00010: Matrix A - DLY_IN; Matrix B - In1; Matrix C - In0 (DLY_OUT connected to In2)
		CNT/DLY → DFF	00110: Matrix A - DLY_IN; Matrix B - nSET/nRST; Matrix C - CLK (DLY_OUT connected to D)
		CNT/DLY → LUT	01010: Matrix A - In2; Matrix B - DLY_IN; Matrix C - In0 (DLY_OUT connected to In1)
		CNT/DLY → DFF	01110: Matrix A - D; Matrix B - DLY_IN; Matrix C - CLK (DLY_OUT connected to nSET/nRST)
		CNT/DLY → LUT	10010: Matrix A - In2; Matrix B - In1; Matrix C - DLY_IN (DLY_OUT connected to In0)
		CNT/DLY → DFF	10110: Matrix A - D; Matrix B - nSET/nRST; Matrix C - DLY_IN (DLY_OUT connected to CLK)
		LUT → CNT/DLY	00011: Matrix A - In2; Matrix B - In1; Matrix C - In0 (LUT_OUT connected to DLY_IN)
		DFF → CNT/DLY	00111: Matrix A - D; Matrix B - nSET/nRST; Matrix C - CLK (DFF_OUT connected to DLY_IN)
	1487:1486	CNT5 initial value selection	00: bypass the initial 01: initial 0 10: initial 1 11: initial 1
BA	1495:1488	LUT3_11_DFF14 setting	[7]: LUT3_11[7]/DFF or LATCH Select 0: DFF function; 1: LATCH function [6]: LUT3_11[6]/DFF Output Select 0: Q output; 1: QB output [5]: LUT3_11[5]/DFF 0: nRST from Matrix Output; 1: nSET from Matrix Output [4]: LUT3_11[4]/DFF Initial Polarity Select 0: Low; 1: High [3:0]: LUT3_11[3:0]
BB	1499:1496	DLY/CNT5 Clock Source Select	Clock source SEL [3:0] 0000: 25M(OSC2); 0001: 25M/4; 0010: 2M(OSC1); 0011: 2M/8; 0100: 2M/64; 0101: 2M/512; 0110: 2K(OSC0); 0111: 2K/8; 1000: 2K/64; 1001: 2K/512; 1010: 2K/4096; 1011: 2K/32768; 1100: 2K/262144; 1101: CNT_END; 1110: External; 1111: Not used
	1503:1500	CNT5 function and edge mode selection	0000: both edge Delay; 0001: falling edge delay; 0010: rising edge delay; 0011: both edge One Shot; 0100: falling edge One Shot; 0101: rising edge One Shot; 0110: both edge freq detect; 0111: falling edge freq detect; 1000: rising edge freq detect; 1001: both edge detect; 1010: falling edge detect; 1011: rising edge detect; 1100: both edge reset CNT; 1101: falling edge reset CNT; 1110: rising edge reset CNT; 1111: high level reset CNT
BC	1511:1504	REG_CNT5_Data[7:0]	Data[7:0]

SLG46827-A

Auto AEC-Q100 Qualified GreenPAK Programmable Mixed-Signal Matrix with In-System Debug

Table 58: Register Map (Continued)

Address		Signal Function	Register Bit Definition
Byte	Register Bit		
BD	1512	CNT5 output pol selection	0: Default Output 1: Inverted Output
	1513	Reserved	
	1514	CNT5 CNT mode SYNC selection	0: bypass 1: after two DFF
	1515	CNT5 DLY EDET FUNCTION Selection	0: normal 1: DLY function edge detection
	1538, 1519:1516	Single 3-bit LUT	00000: Matrix A - In2; Matrix B - In1; Matrix C - In0 (DLY_IN - LOW)
	Single DFF w RST and SET	10000: Matrix A - D; Matrix B - nSET/nRST; Matrix C - CLK (DLY_IN - LOW)	
BD	1538, 1519:1516	Single CNT/DLY	00001: Matrix A - DLY_IN (CNT); Matrix B - EXT_CLK (CNT); Matrix C - NC (DLY_OUT connected to LUT/DFF)
		CNT/DLY → LUT	00010: Matrix A - DLY_IN; Matrix B - In1; Matrix C - In0 (DLY_OUT connected to In2)
		CNT/DLY → DFF	10010: Matrix A - DLY_IN; Matrix B - nSET/nRST; Matrix C - CLK (DLY_OUT connected to D)
		CNT/DLY → LUT	00110: Matrix A - In2; Matrix B - DLY_IN; Matrix C - In0 (DLY_OUT connected to In1)
		CNT/DLY → DFF	10110: Matrix A - D; Matrix B - DLY_IN; Matrix C - CLK (DLY_OUT connected to nSET/nRST)
		CNT/DLY → LUT	01010: Matrix A - In2; Matrix B - In1; Matrix C - DLY_IN (DLY_OUT connected to In0)
		CNT/DLY → DFF	11010: Matrix A - D; Matrix B - nSET/nRST; Matrix C - DLY_IN (DLY_OUT connected to CLK)
		LUT → CNT/DLY	00011: Matrix A - In2; Matrix B - In1; Matrix C - In0 (LUT_OUT connected to DLY_IN)
		DFF → CNT/DLY	10011: Matrix A - D; Matrix B - nSET/nRST; Matrix C - CLK (DFF_OUT connected to DLY_IN)
BE	1527:1520	LUT3_12_DFF15 setting	[7]: LUT3_12[7]/DFF or LATCH Select 0: DFF function; 1: LATCH function [6]: LUT3_12[6]/DFF Output Select 0: Q output; 1: QB output [5]: LUT3_12[5]/DFF 0: nRST from Matrix Output; 1: nSET from Matrix Output [4]: LUT3_12[4]/DFF Initial Polarity Select 0: Low; 1: High [3:0]: LUT3_12[3:0]

SLG46827-A

Auto AEC-Q100 Qualified GreenPAK Programmable Mixed-Signal Matrix with In-System Debug

Table 58: Register Map (Continued)

Address		Signal Function	Register Bit Definition
Byte	Register Bit		
BF	1531:1528	DLY/CNT6 Clock Source Select	Clock source SEL [3:0] 0000: 25M(OSC2); 0001: 25M/4; 0010: 2M(OSC1); 0011: 2M/8; 0100: 2M/64; 0101: 2M/512; 0110: 2K(OSC0); 0111: 2K/8; 1000: 2K/64; 1001: 2K/512; 1010: 2K/4096; 1011: 2K/32768; 1100: 2K/262144; 1101: CNT_END; 1110: External; 1111: Not used
	1535:1532	CNT6 function and edge mode selection	0000: both edge Delay; 0001: falling edge delay; 0010: rising edge delay; 0011: both edge One Shot; 0100: falling edge One Shot; 0101: rising edge One Shot; 0110: both edge freq detect; 0111: falling edge freq detect; 1000: rising edge freq detect; 1001: both edge detect; 1010: falling edge detect; 1011: rising edge detect; 1100: both edge reset CNT; 1101: falling edge reset CNT; 1110: rising edge reset CNT; 1111: high level reset CNT
C0	1537:1536	CNT6 initial value selection	00: bypass the initial 01: initial 0 10: initial 1 11: initial 1
	1539	CNT6 output pol selection	0: Default Output 1: Inverted Output
	1540	Reserved	
	1541	CNT6 CNT mode SYNC selection	0: bypass 1: after two DFF
	1542	CNT6 DLY EDET FUNCTION Selection	0: normal 1: DLY function edge detection
	1543	Reserved	
C1	1551:1544	REG_CNT6_Data[7:0]	Data[7:0]
C2	1556:1552	Single 3-bit LUT	00000: Matrix A - In2; Matrix B - In1; Matrix C - In0 (DLY_IN - LOW)
		Single DFF w RST and SET	10000: Matrix A - D; Matrix B - nSET/nRST; Matrix C - CLK (DLY_IN - LOW)

SLG46827-A

Auto AEC-Q100 Qualified GreenPAK Programmable Mixed-Signal Matrix with In-System Debug

Table 58: Register Map (Continued)

Address		Signal Function	Register Bit Definition
Byte	Register Bit		
C2	1556:1552	Single CNT/DLY	00001: Matrix A - DLY_IN (CNT); Matrix B - EXT_CLK (CNT); Matrix C - NC (DLY_OUT connected to LUT/DFF)
		CNT/DLY → LUT	00010: Matrix A - DLY_IN; Matrix B - In1; Matrix C - In0 (DLY_OUT connected to In2)
		CNT/DLY → DFF	10010: Matrix A - DLY_IN; Matrix B - nSET/nRST; Matrix C - CLK (DLY_OUT connected to D)
		CNT/DLY → LUT	00110: Matrix A - In2; Matrix B - DLY_IN; Matrix C - In0 (DLY_OUT connected to In1)
		CNT/DLY → DFF	10110: Matrix A - D; Matrix B - DLY_IN; Matrix C - CLK (DLY_OUT connected to nSET/nRST)
		CNT/DLY → LUT	01010: Matrix A - In2; Matrix B - In1; Matrix C - DLY_IN (DLY_OUT connected to In0)
		CNT/DLY → DFF	11010: Matrix A - D; Matrix B - nSET/nRST; Matrix C - DLY_IN (DLY_OUT connected to CLK)
		LUT → CNT/DLY	00011: Matrix A - In2; Matrix B - In1; Matrix C - In0 (LUT_OUT connected to DLY_IN)
		DFF → CNT/DLY	10011: Matrix A - D; Matrix B - nSET/nRST; Matrix C - CLK (DFF_OUT connected to DLY_IN)
		1557	CNT7 output pol selection
	1558	Reserved	
	1559	CNT7 CNT mode SYNC selection	0: bypass 1: after two DFF
C3	1567:1560	LUT3_13_DFF16 setting	[7]: LUT3_13[7]/DFF or LATCH Select 0: DFF function; 1: LATCH function [6]: LUT3_13[6]/DFF Output Select 0: Q output; 1: QB output [5]: LUT3_13[5]/DFF 0: nRST from Matrix Output; 1: nSET from Matrix Output [4]: LUT3_13[4]/DFF Initial Polarity Select 0: Low; 1: High [3:0]: LUT3_13[3:0]
C4	1571:1568	DLY/CNT7 Clock Source Select	Clock source SEL [3:0] 0000: 25M(OSC2); 0001: 25M/4; 0010: 2M(OSC1); 0011: 2M/8; 0100: 2M/64; 0101: 2M/512; 0110: 2K(OSC0); 0111: 2K/8; 1000: 2K/64; 1001: 2K/512; 1010: 2K/4096; 1011: 2K/32768; 1100: 2K/262144; 1101: CNT_END; 1110: External; 1111: Not used
	1575:1572	CNT7 function and edge mode selection	0000: both edge Delay; 0001: falling edge delay; 0010: rising edge delay; 0011: both edge One Shot; 0100: falling edge One Shot; 0101: rising edge One Shot; 0110: both edge freq detect; 0111: falling edge freq detect; 1000: rising edge freq detect; 1001: both edge detect; 1010: falling edge detect; 1011: rising edge detect; 1100: both edge reset CNT; 1101: falling edge reset CNT; 1110: rising edge reset CNT; 1111: high level reset CNT

SLG46827-A

Auto AEC-Q100 Qualified GreenPAK Programmable Mixed-Signal Matrix with In-System Debug

Table 58: Register Map (Continued)

Address		Signal Function	Register Bit Definition
Byte	Register Bit		
C5	1577:1576	CNT7 initial value selection	00: bypass the initial 01: initial 0 10: initial 1 11: initial 1
	1578	CNT7 DLY EDET FUNCTION Selection	0: normal 1: DLY function edge detection
	1583:1579	Reserved	
C6	1591:1584	REG_CNT7_Data[7:0]	Data[7:0]
C7	1592	IO0 I ² C output expander data	
	1593	IO0 I ² C output expander select	0: IO0 output come from matrix 1: IO0 output is register
	1594	IO5 I ² C output expander data	
	1595	IO5 I ² C output expander select	0: IO5 output come from matrix 1: IO5 output is register
	1596	IO6 I ² C output expander data	
	1597	IO6 I ² C output expander select	0: IO6 output come from matrix 1: IO6 output is register
	1598	IO9 I ² C output expander data	
C8	1599	IO9 I ² C output expander select	0: IO9 output come from matrix 1: IO9 output is register
	1600	Reserved	
	1601	I ² C reset bit with reloading NVM into Data register (soft reset)	0: Keep existing condition 1: Reset execution
	1602	IO latching enable during I ² C write interface	1: disable 0: enable
	1607:1603	Reserved	
C9	1615:1608	I ² C write mask bits	0: overwrite 1: mask
CA	1619:1616	I ² C slave address	
	1620	Slave address selection SA4	0: from register 1: from IO2
	1621	Slave address selection SA5	0: from register 1: from IO3
	1622	Slave address selection SA6	0: from register 1: from IO4
	1623	Slave address selection SA7	0: from register 1: from IO5
CB	1631:1624	8-bit Pattern ID Byte 0 (From NVM): ID[23:16]	
CC	1639:1632	Reserved	
Reserved			
CD	1643:1640	Reserved	
	1647:1644	Reserved	

SLG46827-A

Auto AEC-Q100 Qualified GreenPAK Programmable Mixed-Signal Matrix with In-System Debug

Table 58: Register Map (Continued)

Address		Signal Function	Register Bit Definition
Byte	Register Bit		
CE	1648	Reserved	
	1652:1649	Reserved	
	1653	Reserved	
	1654	Reserved	
	1655	Reserved	
CF	1657:1656	Reserved	
	1658	Reserved	
	1659	Reserved	
	1660	Reserved	
	1661	Reserved	
	1662	Reserved	
	1663	Reserved	
D0	1671:1664	Reserved	
D1	1679:1672	Reserved	
D2	1687:1680	Reserved	
D3	1695:1688	Reserved	
D4	1703:1696	Reserved	
D5	1711:1704	Reserved	
D6	1719:1712	Reserved	
D7	1727:1720	Reserved	
D8	1735:1728	Reserved	
D9	1743:1736	Reserved	
DA	1751:1744	Reserved	
DB	1759:1752	Reserved	
DC	1767:1760	Reserved	
DD	1775:1768	Reserved	
DE	1783:1776	Reserved	
DF	1791:1784	Reserved	
E0 RPR	1793:1792	2k Register Read Selection Bits RPRB[1:0]	00: 2k register data is unprotected for read; 01: 2k register data is partly protected for read; 10: 2k register data is fully protected for read; 11: reserved
	1795:1794	2k Register Write Selection Bits RPRB[3:2]	00: 2k register data is unprotected for write; 01: 2k register data is partly protected for write; 10: 2k register data is fully protected for write; 11: reserved
	1796	Reserved	
	1797	Reserved	
	1798	Reserved	
	1799	Reserved	

SLG46827-A

Auto AEC-Q100 Qualified GreenPAK Programmable Mixed-Signal Matrix with In-System Debug

Table 58: Register Map (Continued)

Address		Signal Function	Register Bit Definition
Byte	Register Bit		
E1 NPR	1801:1800	2k NVM Configuration Selection Bits NPRB[1:0]	00: 2k NVM Configuration data is unprotected for read and write/erase; 01: 2k NVM Configuration data is fully protected for read; 10: 2k NVM Configuration data is fully protected for write/erase; 11: 2k NVM Configuration data is fully protected for read and write/erase.
	1802	Reserved	
	1803	Reserved	
	1804	Reserved	
	1805	Reserved	
	1806	Reserved	
	1807	Reserved	
E2 WPR	1809:1808	Reserved	
	1810	Write Protect Register Enable	0: No Software Write Protection enabled (default). 1: Write Protection is set by the state of the WPB[1:0] bits.
	1815:1811	Reserved	
E3	1820:1816	Page Selection for Erase ERSEB[4:0]	Define the page address which will be erased. ERSEB[4] = 0 corresponds to the upper 2k NVM used for chip configuration;
	1821	Reserved	
	1822	Reserved	
	1823	Erase Enable ERSE	0: erase disable 1: cause the NVM erase: full NVM (4k bits) erase for ERSCHIP = 1 (reg[1973]) if DIS_ERCHIP = 0 (reg[1972]) or page erase for ERSCHIP = 0 (reg[1973]).
E4	1824	Protection Lock Bit (PRL)	0: RPR/WPR/NPR setting can be changed 1: RPR/WPR/NPR setting cannot be changed
	1831:1825	Reserved	
E5	1839:1832	Reserved	
E6	1847:1840	Reserved	
E7	1855:1848	Reserved	
E8	1863:1856	Reserved	
E9	1871:1864	Reserved	
EA	1879:1872	Reserved	
EB	1887:1880	Reserved	
EC	1895:1888	Reserved	
ED	1903:1896	Reserved	
EE	1911:1904	Reserved	
EF	1919:1912	Reserved	
F0	1926:1920	Reserved	
	1927	Reserved	
F1	1932:1928	Reserved	
	1934:1933		
	1935	Reserved	

SLG46827-A

Auto AEC-Q100 Qualified GreenPAK Programmable Mixed-Signal Matrix with In-System Debug

Table 58: Register Map (Continued)

Address		Signal Function	Register Bit Definition
Byte	Register Bit		
F2	1940:1936	Reserved	
	1943:1941		
F3	1949:1944	Reserved	
	1951:1950		
F4	1957:1952	Reserved	
	1959:1958		
F5	1965:1960	Reserved	
	1967:1966		
F6	1968	Reserved	
	1971:1969	Reserved	
	1972	Reserved	
	1973	Reserved	
	1974	Reserved	
	1975	Reserved	
F7	1983:1976	Reserved	
F8	1991:1984	Reserved	
F9	1992	Reserved	
	1993	Reserved	
	1995:1994	Reserved	
	1999:1996	Reserved	
FA	2000	Reserved	
	2001	Reserved	
	2002	Reserved	
	2006:2003		
	2007	Reserved	
FB	2015:2008	Reserved	
FC	2023:2016	Reserved	
FD	2031:2024	Reserved	
FE	2039:2032	Reserved	
FF	2047:2040	Reserved	

SLG46827-A

Auto AEC-Q100 Qualified GreenPAK
 Programmable Mixed-Signal Matrix with In-System Debug

19 Package Top Marking System Definition

19.1 TSSOP-20

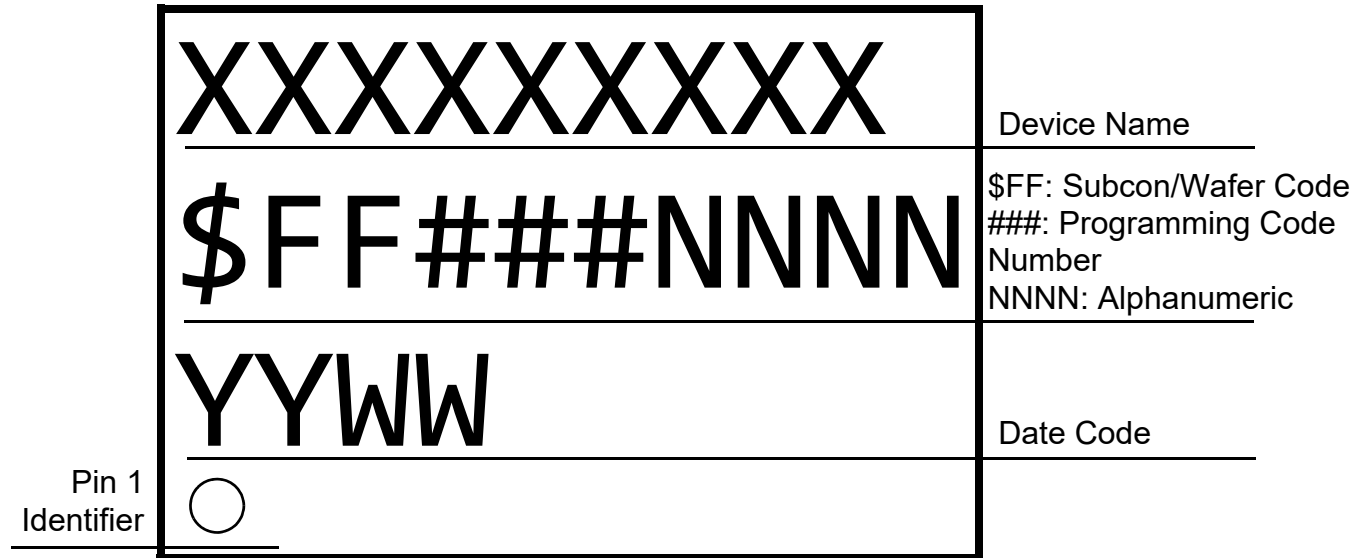

SLG46827-A

Auto AEC-Q100 Qualified GreenPAK Programmable Mixed-Signal Matrix with In-System Debug

20 Package Information

20.1 PACKAGE OUTLINES FOR TSSOP 20L 173 MIL GREEN PACKAGE

JEDEC MO-220, Variation WECE
IC Net Weight: 0.083 g

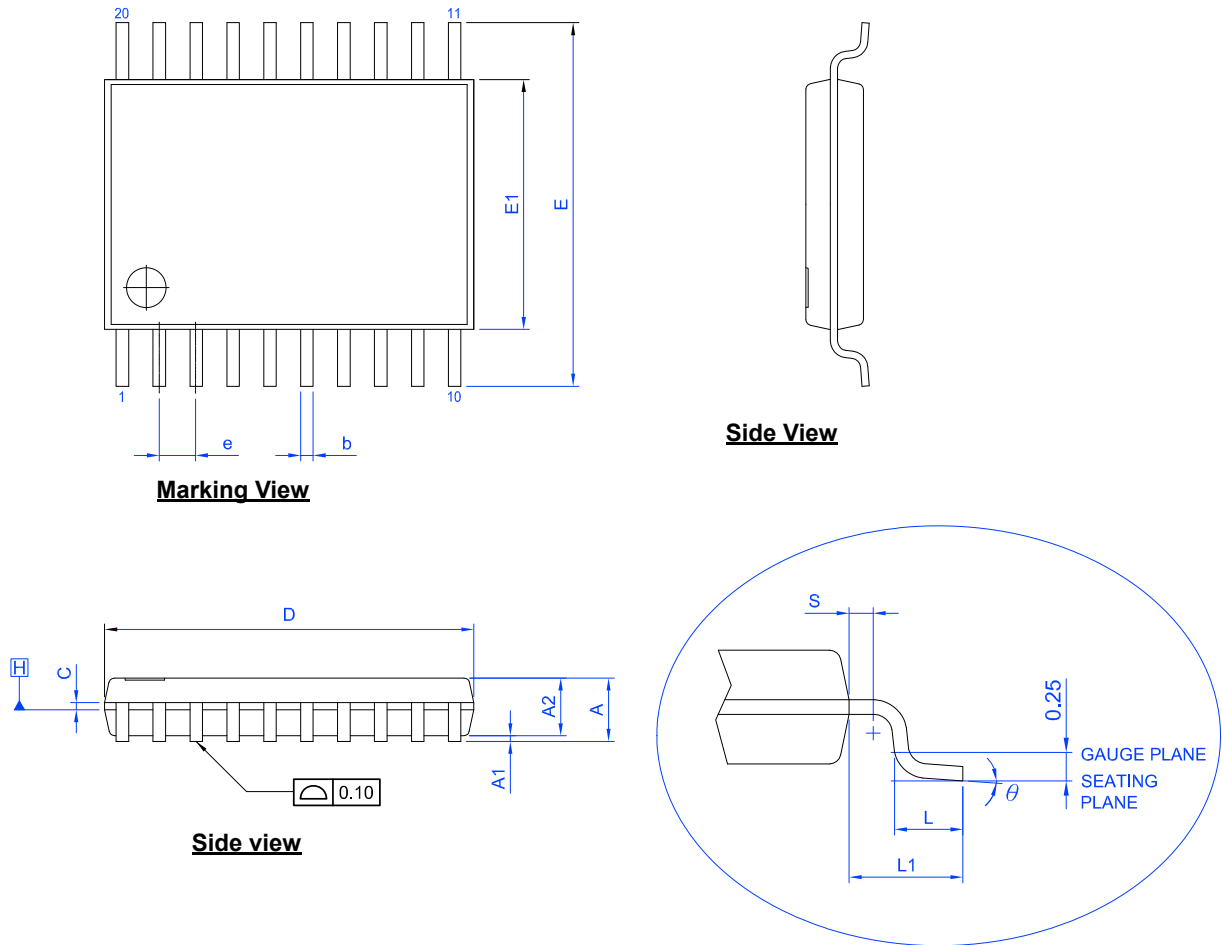

Unit: mm

Symbol	Min	Nom.	Max	Symbol	Min	Nom.	Max
A	-	-	1.20	D	6.40	6.50	6.60
A1	0.05	-	0.15	E1	4.30	4.40	4.50
A2	0.80	0.90	1.05	E	6.40 BSC		
b	0.19	-	0.30	L	0.50	0.60	0.75
C	0.09	-	0.20	L1	1.00 REF		
e	0.65 BSC			S	0.20	-	-
				Θ	0°	-	8°

NOTES:

1. JEDEC OUTLINE :
STANDARD : MO-153 AC REV.F
THERMALLY ENHANCED : MO-153 ACT REV.F
2. DIMENSION 'D' DOES NOT INCLUDE MOLD FLASH, PROTRUSIONS OR GATE BURRS. MOLD FLASH, PROTRUSIONS OR GATE BURRS SHALL NOT EXCEED 0.15 PER SIDE.
3. DIMENSION 'E1' DOES NOT INCLUDE INTERLEAD FLASH OR PROTRUSION. INTERLEAD FLASH OR PROTRUSION SHALL NOT EXCEED 0.25 PER SIDE.
4. DIMENSION 'b' DOES NOT INCLUDE DAMBAR PROTRUSION. ALLOWABLE DAMBAR PROTRUSION SHALL BE 0.08 MM TOTAL IN EXCESS OF THE 'b' DIMENSION AT MAXIMUM MATERIAL CONDITION. DAMBAR CANNOT BE LOCATED ON THE LOWER RADIUS OF THE FOOT. MINIMUM SPACE BETWEEN PROTRUSION AND ADJACENT LEAD IS 0.07 MM.
5. DIMENSIONS 'D' AND 'E1' TO BE DETERMINED AT DATUM PLANE H

20.2 TSSOP HANDLING

Be sure to handle TSSOP package only in a clean, ESD-safe environment. Tweezers or vacuum pick-up tools are suitable for handling. Do not handle TSSOP package with fingers as this can contaminate the package pins and interface with solder reflow.

SLG46827-A

Auto AEC-Q100 Qualified GreenPAK Programmable Mixed-Signal Matrix with In-System Debug

20.3 SOLDERING INFORMATION

Please see IPC/JEDEC J-STD-020: latest revision for reflow profile based on package volume of 25.74 mm³ (nominal) for TSSOP-20 Package. More information can be found at www.jedec.org.

21 Ordering Information

Part Number	Type
SLG46827-AG	20-pin TSSOP
SLG46827-AGTR	20-pin TSSOP Tape and Reel (4k units)

Note 1 Use SLG46827-AG to order. Shipments are automatically in Tape and Reel.

Note 2 "TR" suffix is no longer used. It is a legacy naming convention shown here only for informational purposes.

21.1 TAPE AND REEL SPECIFICATIONS

Package Type	# of Pins	Nominal Package Size (mm)	Max Units		Reel & Hub Size (mm)	Leader (min)		Trailer (min)		Tape Width (mm)	Part Pitch (mm)
			per Reel	per Box		Pockets	Length (mm)	Pockets	Length (mm)		
TSSOP 20L 173 MIL Green Package	20	6.5 x 6.4	4,000	4,000	330/100	42	336	42	336	16	8

21.2 CARRIER TAPE DRAWING AND DIMENSIONS

Package Type	Pocket BTM Length (mm)	Pocket BTM Width (mm)	Pocket Depth (mm)	Index Hole Pitch (mm)	Pocket Pitch (mm)	Index Hole Diameter (mm)	Index Hole to Tape Edge (mm)	Index Hole to Pocket Center (mm)	Tape Width (mm)
	A0	B0	K0	P0	P1	D0	E	F	W
TSSOP 20L 173 MIL Green Package	6.8	6.9	1.6	4	8	1.5	1.75	7.5	16

21.3 TSSOP-20L

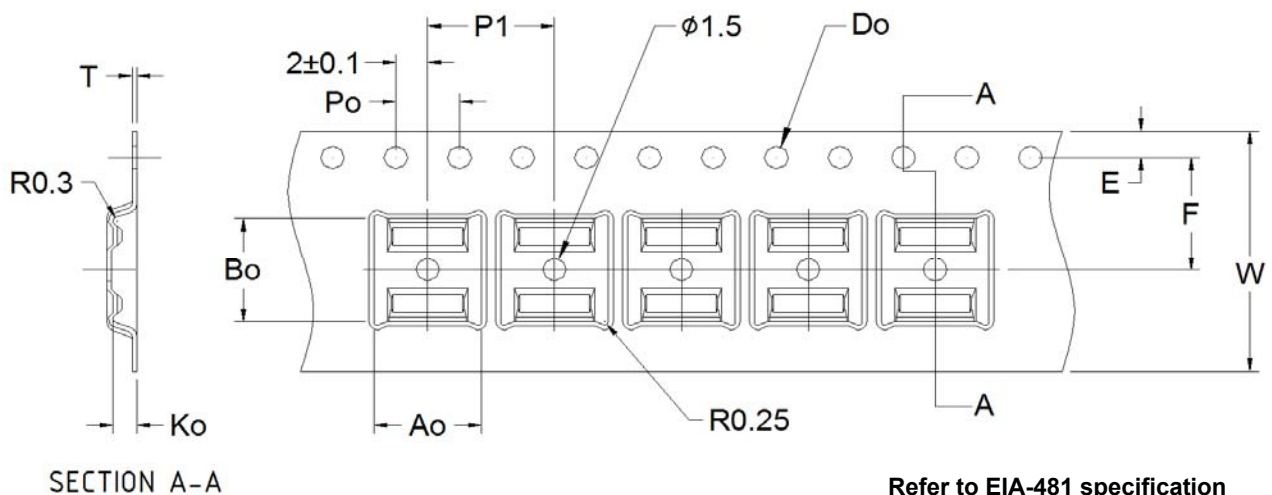

Note: Orientation in carrier: Pin1 is at upper left corner (Quadrant1).

SLG46827-A

Auto AEC-Q100 Qualified GreenPAK
 Programmable Mixed-Signal Matrix with In-System Debug

22 Layout Guidelines

22.1 TSSOP-20

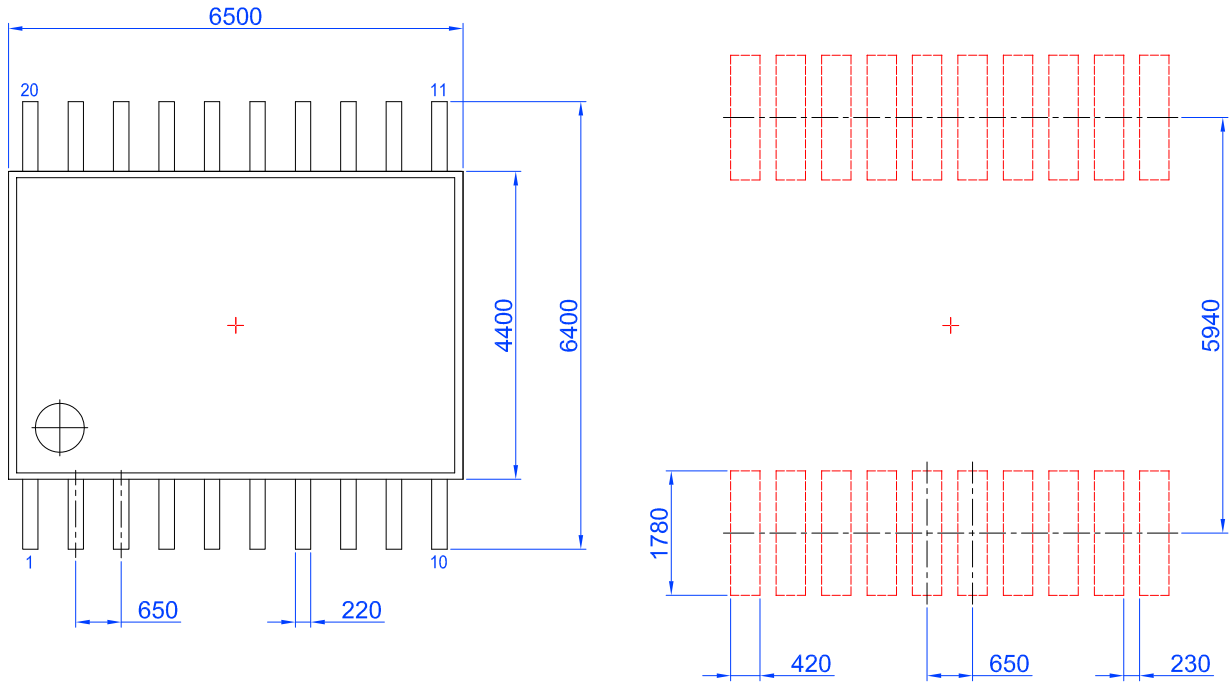

Unit: μm

SLG46827-A

Auto AEC-Q100 Qualified GreenPAK Programmable Mixed-Signal Matrix with In-System Debug

Glossary

A

ACK	Acknowledge bit
ACMP	Analog Comparator
ACMPH	Analog Comparator High Speed
ACMPL	Analog Comparator Low Power

B

BG	Bandgap
----	---------

C

CLK	Clock
CMO	Connection matrix output
CNT	Counter

D

DFF	D Flip-Flop
DLY	Delay

E

EC	Electrical Characteristics
ERSE	Erase Enable
ERSR	Erase Register
ESD	Electrostatic discharge
EV	End Value

F

FSM	Finite State Machine
-----	----------------------

G

GPI	General Purpose Input
GPIO	General Purpose Input/Output
GPO	General Purpose Output

I

IN	Input
IO	Input/Output

SLG46827-A

Auto AEC-Q100 Qualified GreenPAK Programmable Mixed-Signal Matrix with In-System Debug

L

LPF	Low Pass Filter
LSB	Least Significant Bit
LUT	Look Up Table
LV	Low Voltage

M

MSB	Most Significant Bit
MTP	Multiple-Time-Programmable
MUX	Multiplexer

N

NPR	Non-Volatile Memory Read/Write/Erase Protection
nRST	Reset
NVM	Non-Volatile Memory

O

OD	Open-Drain
OE	Output Enable
OSC	Oscillator
OUT	Output

P

PD	Power-down
PGen	Pattern Generator
POR	Power-On Reset
PP	Push-Pull
PRL	Protect Lock Bit
PWR	Power
P DLY	Programmable Delay

R

RPR	Register Read/Write Protection
RPRB	Register Read/Write Protection Bit
RPRL	Register Protection Read/Write/Erase Lock
R/W	Read/Write

S

SCL	I ² C Clock Input
-----	------------------------------

SLG46827-A

Auto AEC-Q100 Qualified GreenPAK Programmable Mixed-Signal Matrix with In-System Debug

SDA I²C Data Input/Output
SLA Slave Address
SMT With Schmitt Trigger
SV nSET Value

T

TS Temperature Sensor

V

Vref Voltage Reference

W

WOSMT Without Schmitt Trigger
WPB Write Protect Bit
WPR Write Protection Register
WPRE Write Protect Enable
WS Wake and Sleep Controller

SLG46827-A

Auto AEC-Q100 Qualified GreenPAK Programmable Mixed-Signal Matrix with In-System Debug

Revision History

Revision	Date	Description
3.15	2-May-2024	Corrected figure I ² C General Timing Characteristics Fixed typos in parameter symbols of Data valid acknowledge time and Data valid time in table I ² C Bus Timing Characteristics Corrected register [1602] definition from 1 to 0 in section Byte Write Command and in section I ² C Additional Options
3.14	30-Nov-2023	Corrected registers [1623:1620]
3.13	10-Oct-2023	Updated Vref Block Diagram Corrected registers [1133:1132] Corrected registers [1316:1315] Corrected ACMP0H Block Diagram Fixed typos Corrected register definitions: [365:360], [377:372], [383:378], [389:384], and [395:390]
3.12	27-Feb-2023	Added notes to section Ordering Information
3.11	23-Feb-2023	Corrected notes in table EC at T = -40 °C to +105 °C, V _{DD} = 2.3 V to 5.5 V
3.10	6-Feb-2023	Updated Package Marking for TSSOP package
3.9	3-Feb-2023	Updated section Analog Comparators
3.8	13-Dec-2022	Added additional information about AEC-Q100
3.7	9-Sep-2022	Added Note to section I ² C Serial Command Register Map
3.6	15-Aug-2022	Corrected parameter R _{PULL} in table EC at T = -40 °C to +105 °C, V _{DD} = 2.3 V to 5.5 V
3.5	5-Aug-2022	Fixed typos Corrected register definitions [987:986]
3.4	8-Mar-2022	Updated Pull-up or Pull-down Resistance Parameter in EC table Renesas rebranding Added IC Net Weight in Package Information section Added information about SCL and SDA Pins' Schmitt Trigger Updated section IO8 Source for Oscillator2 (25 MHz) Corrected Wake and Sleep Controller Block Diagram
3.3	24-Mar-2021	Updated Vref spec
3.2	24-Feb-2021	Updated table ACMP Specifications at T = -40 °C to +105 °C, V _{DD} = 2.3 V to 5.5 V Unless Otherwise Noted
3.1	11-Dec-2020	Updated register definitions: [984], [985]
3.0	12-Oct-2020	Final version Updated table Oscillators Power-On Delay Updated table Oscillators Frequency Limits Updated graphs in OSC Accuracy section Updated graphs ACMPs Typical Propagation Delay vs. Vref Updated graphs in Oscillators Power-On Delay section Fixed typos

SLG46827-A

Auto AEC-Q100 Qualified GreenPAK Programmable Mixed-Signal Matrix with In-System Debug

Status Definitions

Revision	Datasheet Status	Product Status	Definition
1.<n>	Target	Development	This datasheet contains the design specifications for product development. Specifications may change in any manner without notice.
2.<n>	Preliminary	Qualification	This datasheet contains the specifications and preliminary characterization data for products in pre-production. Specifications may be changed at any time without notice in order to improve the design.
3.<n>	Final	Production	This datasheet contains the final specifications for products in volume production. The specifications may be changed at any time in order to improve the design, manufacturing and supply. Major specification changes are communicated via Customer Product Notifications. Datasheet changes are communicated via www.renesas.com .
4.<n>	Obsolete	Archived	This datasheet contains the specifications for discontinued products. The information is provided for reference only.

RoHS Compliance

Renesas Electronics Corporation's suppliers certify that its products are in compliance with the requirements of Directive 2011/65/EU of the European Parliament on the restriction of the use of certain hazardous substances in electrical and electronic equipment. RoHS certificates from our suppliers are available on request.

Notice

1. Descriptions of circuits, software and other related information in this document are provided only to illustrate the operation of semiconductor products and application examples. You are fully responsible for the incorporation or any other use of the circuits, software, and information in the design of your product or system. Renesas Electronics disclaims any and all liability for any losses and damages incurred by you or third parties arising from the use of these circuits, software, or information.
2. Renesas Electronics hereby expressly disclaims any warranties against and liability for infringement or any other claims involving patents, copyrights, or other intellectual property rights of third parties, by or arising from the use of Renesas Electronics products or technical information described in this document, including but not limited to, the product data, drawings, charts, programs, algorithms, and application examples.
3. No license, express, implied or otherwise, is granted hereby under any patents, copyrights or other intellectual property rights of Renesas Electronics or others.
4. You shall be responsible for determining what licenses are required from any third parties, and obtaining such licenses for the lawful import, export, manufacture, sales, utilization, distribution or other disposal of any products incorporating Renesas Electronics products, if required.
5. You shall not alter, modify, copy, or reverse engineer any Renesas Electronics product, whether in whole or in part. Renesas Electronics disclaims any and all liability for any losses or damages incurred by you or third parties arising from such alteration, modification, copying or reverse engineering.
6. Renesas Electronics products are classified according to the following two quality grades: "Standard" and "High Quality". The intended applications for each Renesas Electronics product depends on the product's quality grade, as indicated below.
 - "Standard": Computers; office equipment; communications equipment; test and measurement equipment; audio and visual equipment; home electronic appliances; machine tools; personal electronic equipment; industrial robots; etc.
 - "High Quality": Transportation equipment (automobiles, trains, ships, etc.); traffic control (traffic lights); large-scale communication equipment; key financial terminal systems; safety control equipment; etc.
- Unless expressly designated as a high reliability product or a product for harsh environments in a Renesas Electronics data sheet or other Renesas Electronics document, Renesas Electronics products are not intended or authorized for use in products or systems that may pose a direct threat to human life or bodily injury (artificial life support devices or systems; surgical implantations; etc.), or may cause serious property damage (space system; undersea repeaters; nuclear power control systems; aircraft control systems; key plant systems; military equipment; etc.). Renesas Electronics disclaims any and all liability for any damages or losses incurred by you or any third parties arising from the use of any Renesas Electronics product that is inconsistent with any Renesas Electronics data sheet, user's manual or other Renesas Electronics document.
7. No semiconductor product is absolutely secure. Notwithstanding any security measures or features that may be implemented in Renesas Electronics hardware or software products, Renesas Electronics shall have absolutely no liability arising out of any vulnerability or security breach, including but not limited to any unauthorized access to or use of a Renesas Electronics product or a system that uses a Renesas Electronics product. RENESAS ELECTRONICS DOES NOT WARRANT OR GUARANTEE THAT RENESAS ELECTRONICS PRODUCTS, OR ANY SYSTEMS CREATED USING RENESAS ELECTRONICS PRODUCTS WILL BE INVULNERABLE OR FREE FROM CORRUPTION, ATTACK, VIRUSES, INTERFERENCE, HACKING, DATA LOSS OR THEFT, OR OTHER SECURITY INTRUSION ("Vulnerability Issues"). RENESAS ELECTRONICS DISCLAIMS ANY AND ALL RESPONSIBILITY OR LIABILITY ARISING FROM OR RELATED TO ANY VULNERABILITY ISSUES. FURTHERMORE, TO THE EXTENT PERMITTED BY APPLICABLE LAW, RENESAS ELECTRONICS DISCLAIMS ANY AND ALL WARRANTIES, EXPRESS OR IMPLIED, WITH RESPECT TO THIS DOCUMENT AND ANY RELATED OR ACCOMPANYING SOFTWARE OR HARDWARE, INCLUDING BUT NOT LIMITED TO THE IMPLIED WARRANTIES OF MERCHANTABILITY, OR FITNESS FOR A PARTICULAR PURPOSE.
8. When using Renesas Electronics products, refer to the latest product information (data sheets, user's manuals, application notes, "General Notes for Handling and Using Semiconductor Devices" in the reliability handbook, etc.), and ensure that usage conditions are within the ranges specified by Renesas Electronics with respect to maximum ratings, operating power supply voltage range, heat dissipation characteristics, installation, etc. Renesas Electronics disclaims any and all liability for any malfunctions, failure or accident arising out of the use of Renesas Electronics products outside of such specified ranges.
9. Although Renesas Electronics endeavors to improve the quality and reliability of Renesas Electronics products, semiconductor products have specific characteristics, such as the occurrence of failure at a certain rate and malfunctions under certain use conditions. Unless designated as a high reliability product or a product for harsh environments in a Renesas Electronics data sheet or other Renesas Electronics document, Renesas Electronics products are not subject to radiation resistance design. You are responsible for implementing safety measures to guard against the possibility of bodily injury, injury or damage caused by fire, and/or danger to the public in the event of a failure or malfunction of Renesas Electronics products, such as safety design for hardware and software, including but not limited to redundancy, fire control and malfunction prevention, appropriate treatment for aging degradation or any other appropriate measures. Because the evaluation of microcomputer software alone is very difficult and impractical, you are responsible for evaluating the safety of the final products or systems manufactured by you.
10. Please contact a Renesas Electronics sales office for details as to environmental matters such as the environmental compatibility of each Renesas Electronics product. You are responsible for carefully and sufficiently investigating applicable laws and regulations that regulate the inclusion or use of controlled substances, including without limitation, the EU RoHS Directive, and using Renesas Electronics products in compliance with all these applicable laws and regulations. Renesas Electronics disclaims any and all liability for damages or losses occurring as a result of your noncompliance with applicable laws and regulations.
11. Renesas Electronics products and technologies shall not be used for or incorporated into any products or systems whose manufacture, use, or sale is prohibited under any applicable domestic or foreign laws or regulations. You shall comply with any applicable export control laws and regulations promulgated and administered by the governments of any countries asserting jurisdiction over the parties or transactions.
12. It is the responsibility of the buyer or distributor of Renesas Electronics products, or any other party who distributes, disposes of, or otherwise sells or transfers the product to a third party, to notify such third party in advance of the contents and conditions set forth in this document.
13. This document shall not be reprinted, reproduced or duplicated in any form, in whole or in part, without prior written consent of Renesas Electronics.
14. Please contact a Renesas Electronics sales office if you have any questions regarding the information contained in this document or Renesas Electronics products.

(Note1) "Renesas Electronics" as used in this document means Renesas Electronics Corporation and also includes its directly or indirectly controlled subsidiaries.

(Note2) "Renesas Electronics product(s)" means any product developed or manufactured by or for Renesas Electronics.

(Disclaimer Rev.5.0-1 October 2020)

Corporate Headquarters

TOYOSU FORESIA, 3-2-24 Toyosu,
Koto-ku, Tokyo 135-0061, Japan
www.renesas.com

Trademarks

Renesas and the Renesas logo are trademarks of Renesas Electronics Corporation. All trademarks and registered trademarks are the property of their respective owners.

Contact Information

For further information on a product, technology, the most up-to-date version of a document, or your nearest sales office, please visit:
www.renesas.com/contact/