

SLG59M1736C

An Ultra-small 33 mΩ, 2.2 A pFET Load Switch with Controlled Inrush Current

General Description

Operating from a 2.5 V to 5.5 V power supply, the SLG59M1736C is a self-powered, high-performance 33 mΩ, 2.2 A single-channel pFET load switch with a controlled V_{IN} inrush current profile. The SLG59M1736C's low supply current and controlled V_{IN} inrush current profile makes it an ideal pFET load switch in small form-factor personal health monitor and watch applications.

Using a proprietary MOSFET design, the SLG59M1736C achieves a low $R_{DS(ON)}$ across the entire input voltage range. Through the application of Renesas's proprietary CuFET technology, the SLG59M1736C can be used in applications up to 2.2 A with a very-small 0.64 mm² WLCSP form factor.

Features

- Integrated 2.2 A Continuous I_{DS} pFET Load Switch
- Low Typical $R_{DS(ON)}$:
 - 33 mΩ at $V_{IN} = 5.5$ V
 - 45.1 mΩ at $V_{IN} = 3.3$ V
 - 56.1 mΩ at $V_{IN} = 2.5$ V
- Input Voltage: 2.5 V to 5.5 V
- Low Typical No-load Supply Current: 0.1 μA
- Integrated V_{OUT} Discharge Resistor
- Operating Temperature: -40 °C to 85 °C
- Low θ_{JA} , 4-pin 0.8 mm x 0.8 mm, 0.4 mm pitch 4L WLCSP Packaging
 - Pb-Free / Halogen-Free / RoHS compliant

Pin Configuration

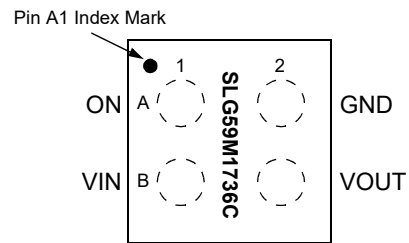

4L WLCSP
(Laser Marking View)

Block Diagram

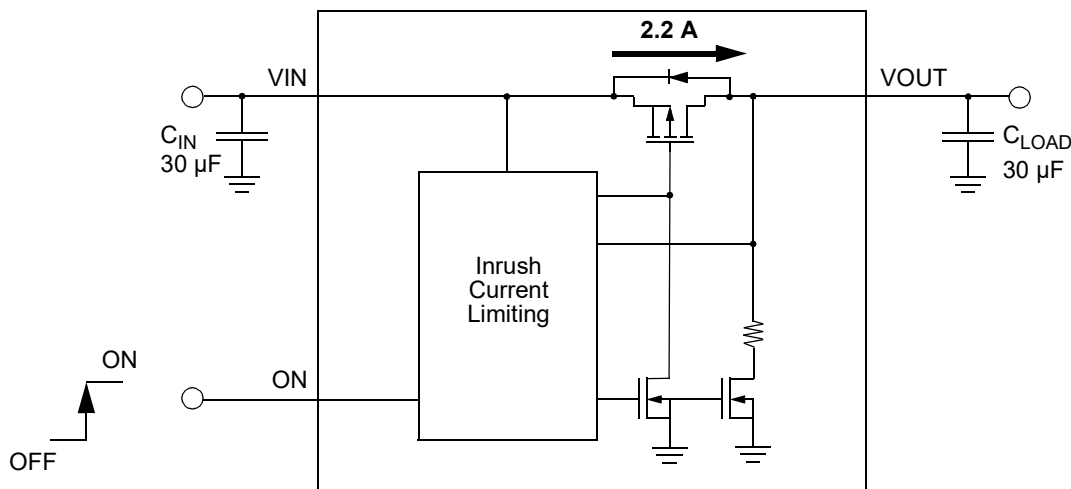

SLG59M1736C

An Ultra-small 33 mΩ, 2.2 A pFET
Load Switch with Controlled Inrush Current

Pin Description

| Pin # | Pin Name | Type | Pin Description |
|-------|----------|--------|---|
| A1 | ON | Input | A low-to-high transition on this pin initiates the operation of the SLG59M1736C. ON is an asserted HIGH, level-sensitive CMOS input with $ON_{V_{IL}} < 0.3\text{ V}$ and $ON_{V_{IH}} > 0.85\text{ V}$. As the ON pin input circuit does not have an internal pull-down resistor, connect this pin to a general-purpose output (GPO) of a microcontroller, an application processor, or a system controller – do not allow this pin to be open-circuited. In order to activate the SLG59M1736C's controlled inrush current control circuitry, ON shall be toggled HIGH only after V_{IN} is higher than the SLG59M1736C's $V_{SUC C(T H)}$ specification. |
| B1 | VIN | MOSFET | Input terminal connection of the p-channel MOSFET. Connect a 10 μF (or larger) low-ESR capacitor from this pin to ground. Capacitors used at VIN should be rated at 10 V or higher. |
| B2 | VOUT | MOSFET | Output terminal connection of the p-channel MOSFET. For optimal operation of the SLG59M1736C controlled inrush current profile, connect a 30 μF (or smaller) capacitor from this pin to ground. Capacitors used at VOUT should be rated at 10 V or higher. |
| A2 | GND | VOUT | Ground connection. Connect this pin to system analog or power ground plane. |

Ordering Information

| Part Number | Type | Production Flow |
|---------------|--------------------------|-----------------------------|
| SLG59M1736C | WLCSP 4L | Industrial, -40 °C to 85 °C |
| SLG59M1736CTR | WLCSP 4L (Tape and Reel) | Industrial, -40 °C to 85 °C |

SLG59M1736C

An Ultra-small 33 mΩ, 2.2 A pFET
Load Switch with Controlled Inrush Current

Absolute Maximum Ratings

| Parameter | Description | Conditions | Min. | Typ. | Max. | Unit | |
|--------------------------|---|---|------------------|------|----------|------|---|
| V_{IN} | Load Switch Input Voltage | | -- | -- | 6 | V | |
| V_{OUT} to GND | Load Switch Output Voltage to GND | | -0.3 | -- | V_{IN} | V | |
| ON to GND | ON Pin Voltage to GND | | -0.3 | -- | V_{IN} | V | |
| T_S | Storage Temperature | | -65 | -- | 140 | °C | |
| ESD _{HBM} | ESD Protection | Human Body Model | 2000 | -- | -- | V | |
| ESD _{CDM} | ESD Protection | Charged Device Model | 1000 | -- | -- | V | |
| MSL | Moisture Sensitivity Level | | 1 | | | | |
| θ_{JA} | Package Thermal Resistance, Junction-to-Ambient | 0.8 x 0.8 mm 4L WLCSP; Determined using a 1 in ² , 2 oz .copper pad under each VIN and VOUT terminal and FR4 pcb material. | -- | 110 | -- | °C/W | |
| W_{DIS} | Package Power Dissipation | | -- | -- | 0.5 | W | |
| MOSFET IDS _{PK} | Peak Current from VIN to VOUT | Maximum pulsed switch current, pulse width < 1 ms, 1% duty cycle | $V_{IN} = 5.5$ V | -- | -- | 2.5 | A |
| | | | $V_{IN} = 2.5$ V | -- | -- | 1.5 | A |

Note: Stresses greater than those listed under "Absolute Maximum Ratings" may cause permanent damage to the device. This is a stress rating only and functional operation of the device at these or any other conditions above those indicated in the operational sections of this specification is not implied. Exposure to absolute maximum rating conditions for extended periods may affect reliability.

Electrical Characteristics

$T_A = -40$ °C to 85 °C (unless otherwise stated). Typical values are at $T_A = 25$ °C

| Parameter | Description | Conditions | Min. | Typ. | Max. | Unit |
|-------------------|--|--|------|----------------|------|------|
| V_{IN} | Load Switch Input Voltage | -40 °C to 85 °C | 2.5 | -- | 5.5 | V |
| I_{IN} | Load Switch Current (Pin B1) | When OFF, $V_{IN} = 5.5$ V, No load | -- | 0.5 | 2 | μA |
| | | When OFF, $V_{IN} = 3.3$ V, No load | -- | 0.06 | 1.5 | μA |
| | | When OFF, $V_{IN} = 3.0$ V, No load | -- | 0.06 | 1 | μA |
| | | When OFF, $V_{IN} = 2.5$ V, No load | -- | 0.06 | 1 | μA |
| | | When ON, ON = V_{IN} , No load | -- | 0.1 | 1 | μA |
| I_{ON_LKG} | ON Pin Input Leakage | | -- | -- | 0.1 | μA |
| RDS _{ON} | ON Resistance | $T_A = 25$ °C, $V_{IN} = 5.5$ V, $I_{DS} = 100$ mA | -- | 33 | 41 | mΩ |
| | | $T_A = 25$ °C, $V_{IN} = 3.3$ V, $I_{DS} = 100$ mA | -- | 45.1 | 55 | mΩ |
| | | $T_A = 25$ °C, $V_{IN} = 2.5$ V, $I_{DS} = 100$ mA | -- | 56.1 | 69 | mΩ |
| | | $T_A = 85$ °C, $V_{IN} = 5.5$ V, $I_{DS} = 100$ mA | -- | 40.2 | 49 | mΩ |
| | | $T_A = 85$ °C, $V_{IN} = 3.3$ V, $I_{DS} = 100$ mA | -- | 54.5 | 66 | mΩ |
| | | $T_A = 85$ °C, $V_{IN} = 2.5$ V, $I_{DS} = 100$ mA | -- | 68.2 | 82 | mΩ |
| MOSFET IDS | Current from VIN to VOUT | Continuous, $V_{IN} = 5$ V | -- | -- | 2.2 | A |
| | | Continuous, $V_{IN} = 2.5$ V | -- | -- | 1.2 | A |
| $V_{SUCC(TH)}$ | V_{IN} Inrush Current Start-up Control Threshold Voltage | ON ≥ ON_ V_{IH} ; See Timing Diagram on Page 4 and Note 1 | -- | 0.9 x V_{IN} | -- | V |

SLG59M1736C

An Ultra-small 33 mΩ, 2.2 A pFET Load Switch with Controlled Inrush Current

Electrical Characteristics (continued)

T_A = -40 °C to 85 °C (unless otherwise stated). Typical values are at T_A = 25 °C

| Parameter | Description | Conditions | Min. | Typ. | Max. | Unit |
|------------------------|-----------------------------|---|------|------|-----------------|------|
| I _{RISE} | Rise Time Charging Current | 10% V _{OUT} to 90% V _{OUT} ↑; V _{IN} = 5.0 V, C _{LOAD} = 30 μF, See Note 1 | 11 | 16.5 | 25 | mA |
| V _{OUT(SR)} | Slew Rate | 10% V _{OUT} to 90% V _{OUT} ↑; V _{IN} = 5.0 V, C _{LOAD} = 30 μF | 0.36 | 0.54 | 0.8 | V/ms |
| T _{RISE} | Rise Time | 10% V _{OUT} to 90% V _{OUT} ↑ V _{IN} = 5.0 V, C _{LOAD} = 30 μF, no R _{LOAD} | 5 | 7.6 | 11 | ms |
| | | 10% V _{OUT} to 90% V _{OUT} ↑ V _{IN} = 2.5 V, C _{LOAD} = 30 μF, no R _{LOAD} | 2.5 | 3.8 | 5.5 | ms |
| T _{Total_ON} | Total Turn On Time | ON_V _{IH} to 90% V _{OUT} ↑ V _{IN} = 5 V, C _{LOAD} = 30 μF, No R _{LOAD} | 6 | 8.6 | 12 | ms |
| | | ON_V _{IH} to 90% V _{OUT} ↑ V _{IN} = 2.5 V, C _{LOAD} = 30 μF, No R _{LOAD} | 3 | 4.3 | 6 | ms |
| T _{OFF_Delay} | OFF Delay Time | ON_V _{IL} to V _{OUT} Fall Start ↓, V _{IN} = 5 V, R _{LOAD} = 10 Ω, no C _{LOAD} | -- | 4.5 | -- | μs |
| C _{LOAD} | Output Load Capacitance | C _{LOAD} connected from V _{OUT} to GND | -- | -- | 30 | μF |
| R _{DISCHARGE} | Discharge Resistance | V _{IN} = 2.5 V to 5.5 V, V _{OUT} = 0.4 V Input Bias | 53 | 90 | 150 | Ω |
| ON_V _{IH} | Initial Turn On Voltage | | 0.85 | -- | V _{IN} | V |
| ON_V _{IL} | Low Input Voltage on ON pin | | -0.3 | 0 | 0.3 | V |

Notes:

- Rise of ON pin must only occur after V_{IN} reaches V_{SUCC(TH)} in order to have proper inrush current limiting and start-up.

T_{Total_ON}, T_{ON_Delay} and Rise Time Measurement

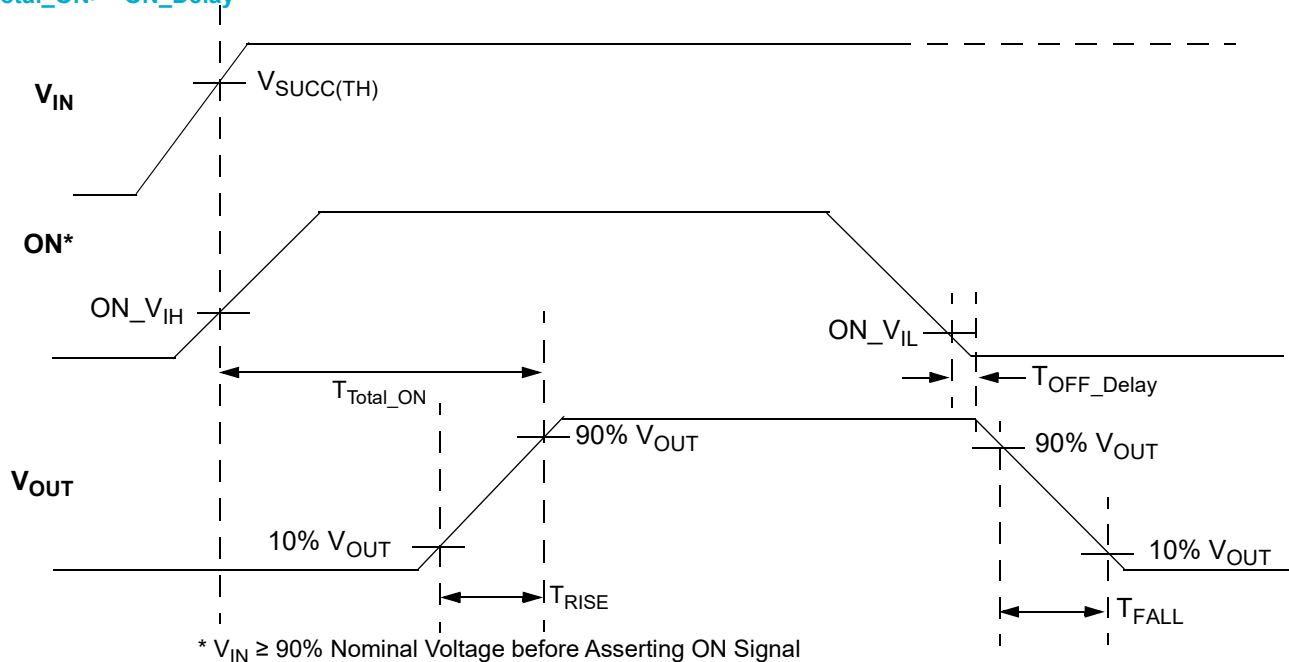

SLG59M1736C

An Ultra-small 33 mΩ, 2.2 A pFET Load Switch with Controlled Inrush Current

Typical Performance Characteristics

RDS_{ON} vs. Temperature and V_{IN}

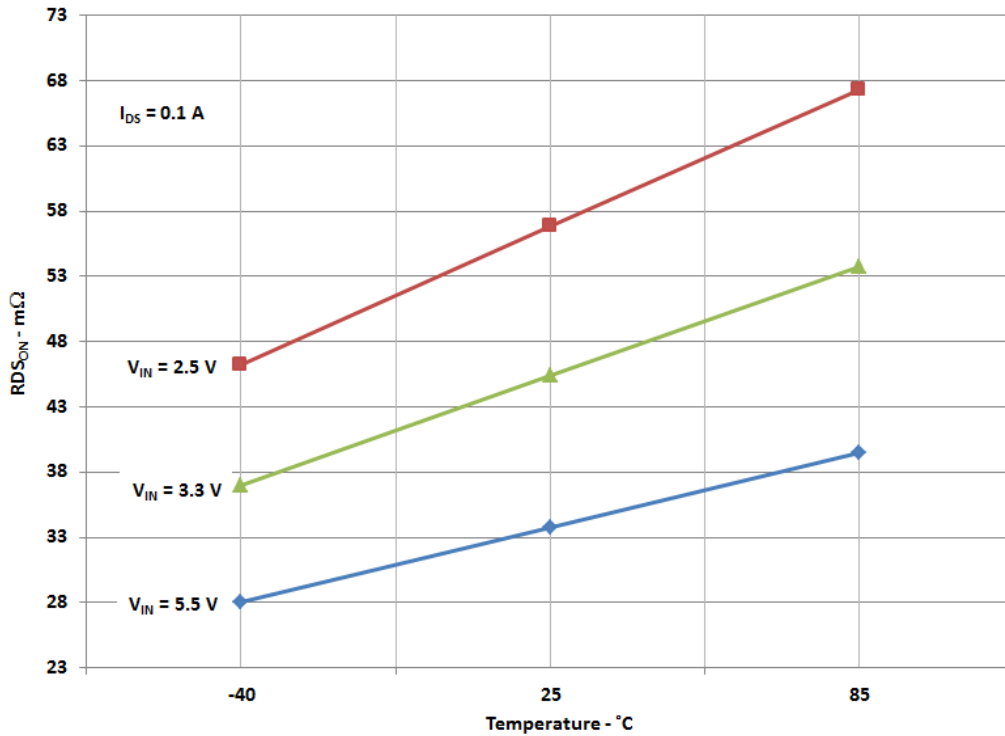

T_{RISE} vs. C_{LOAD}, Temperature, and V_{IN}

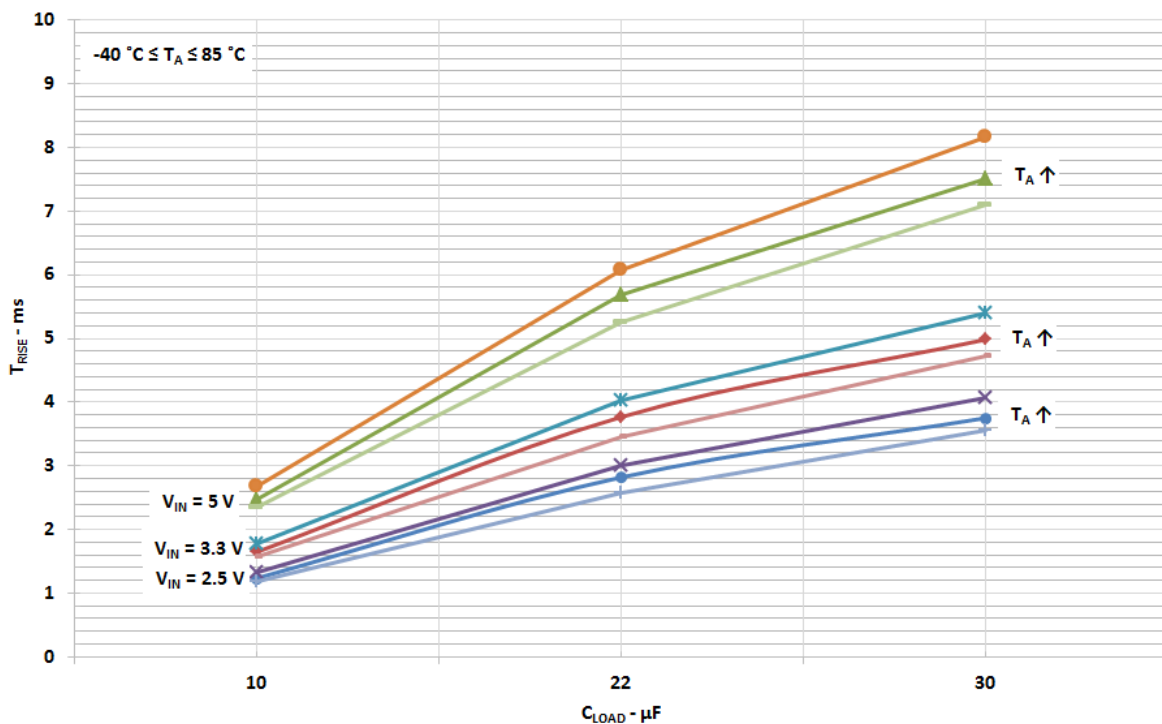

SLG59M1736C

An Ultra-small 33 mΩ, 2.2 A pFET Load Switch with Controlled Inrush Current

T_{Total_ON} vs. C_{LOAD}, Temperature, and V_{IN}

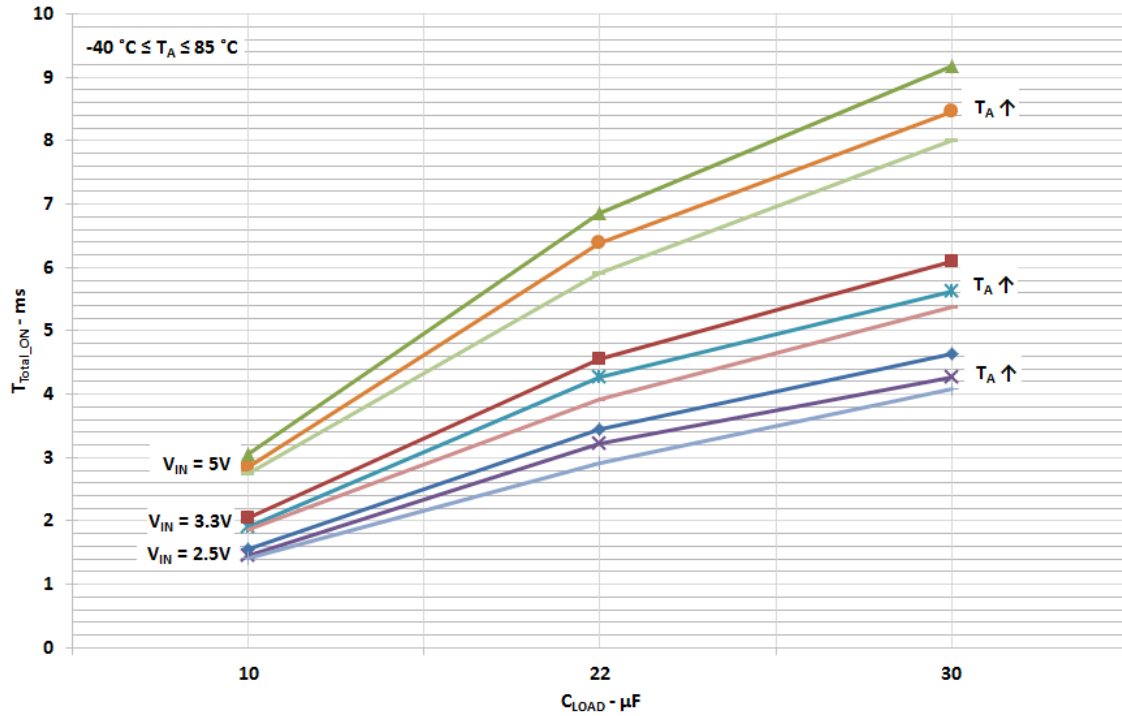

V_{IN} vs. Max I_{DS}, Safe Operation Area

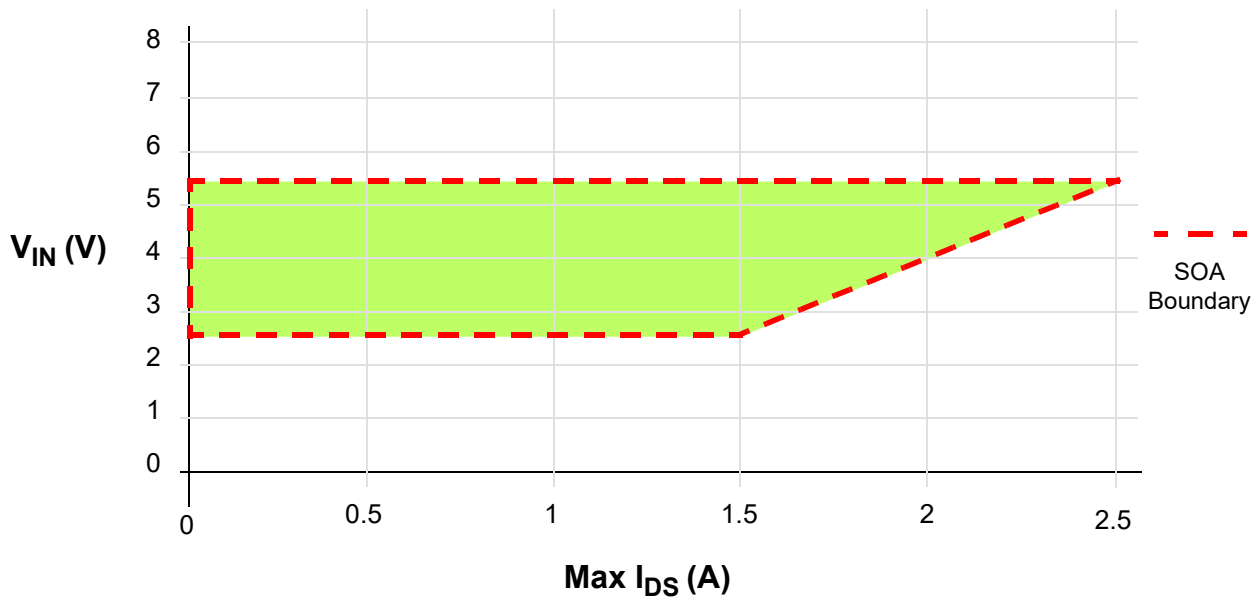

SLG59M1736C

An Ultra-small 33 mΩ, 2.2 A pFET Load Switch with Controlled Inrush Current

Typical Turn-on Waveforms

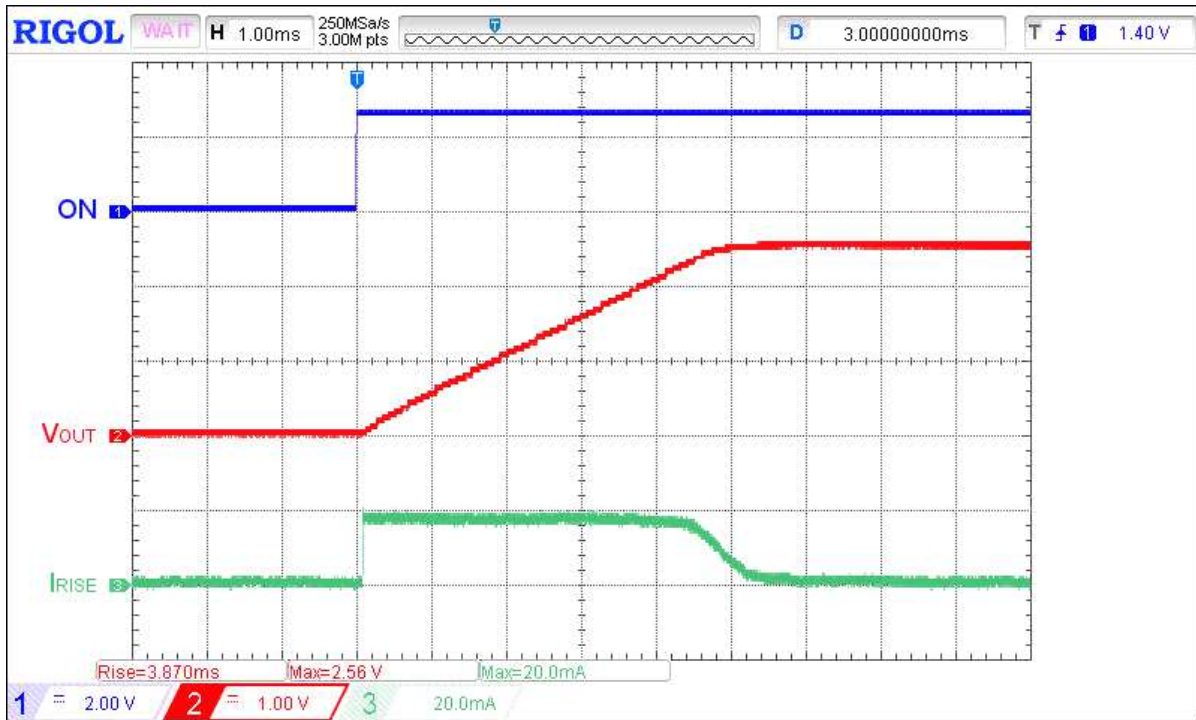

Figure 1. Typical Turn ON operation waveform for $V_{IN} = 2.5\text{ V}$, $C_{LOAD} = 30\ \mu\text{F}$

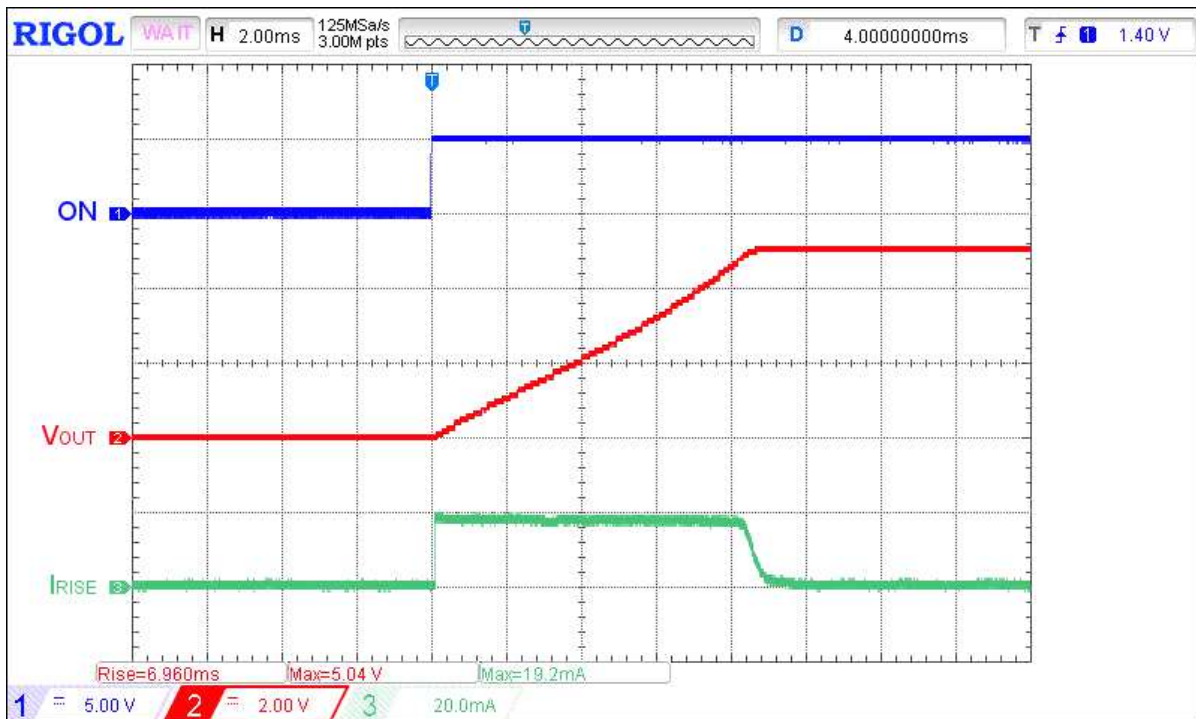

Figure 2. Typical Turn ON operation waveform for $V_{IN} = 5\text{ V}$, $C_{LOAD} = 30\ \mu\text{F}$

SLG59M1736C

An Ultra-small 33 mΩ, 2.2 A pFET Load Switch with Controlled Inrush Current

Typical Turn-off Waveforms

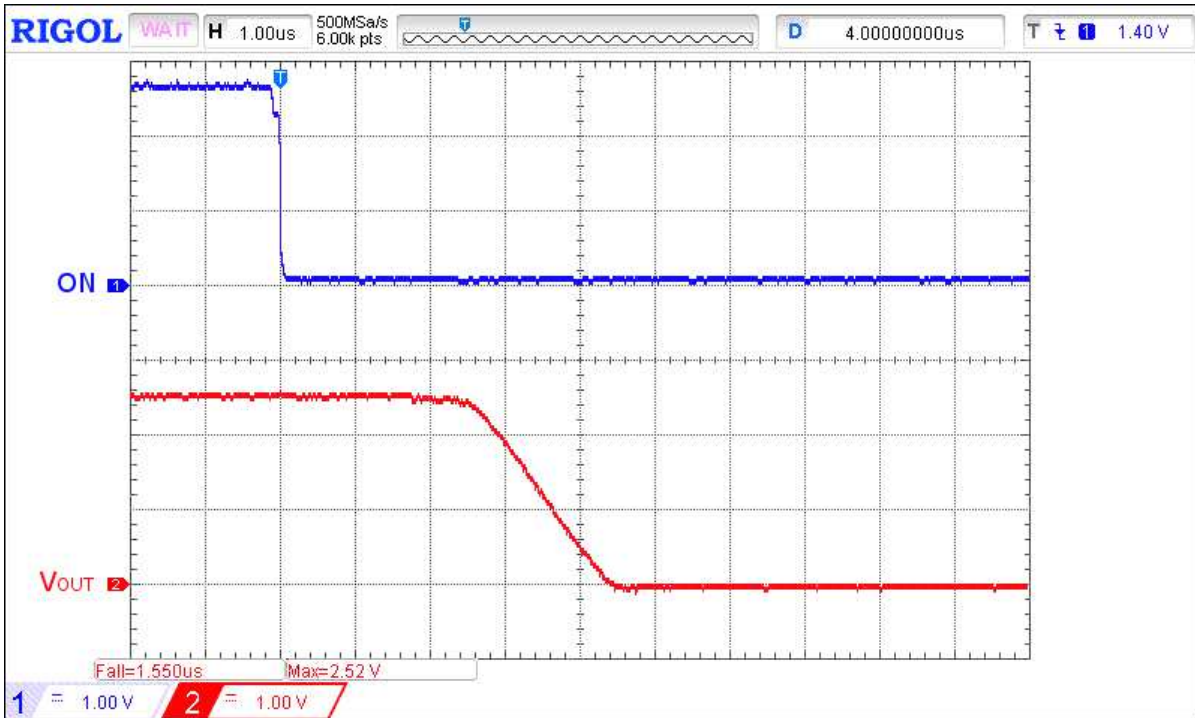

Figure 3. Typical Turn OFF operation waveform for $V_{IN} = 2.5\text{ V}$, no C_{LOAD} , $R_{LOAD} = 10\ \Omega$

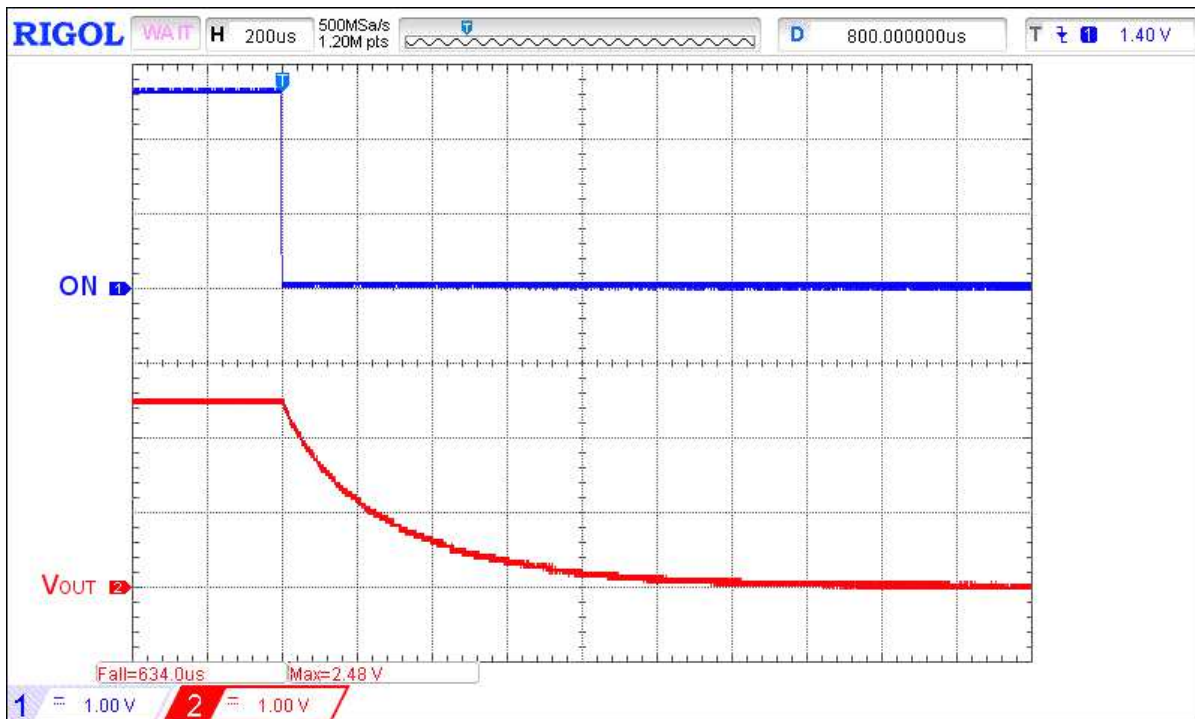

Figure 4. Typical Turn OFF operation waveform for $V_{IN} = 2.5\text{ V}$, $C_{LOAD} = 30\ \mu\text{F}$, $R_{LOAD} = 10\ \Omega$

SLG59M1736C

An Ultra-small 33 mΩ, 2.2 A pFET Load Switch with Controlled Inrush Current

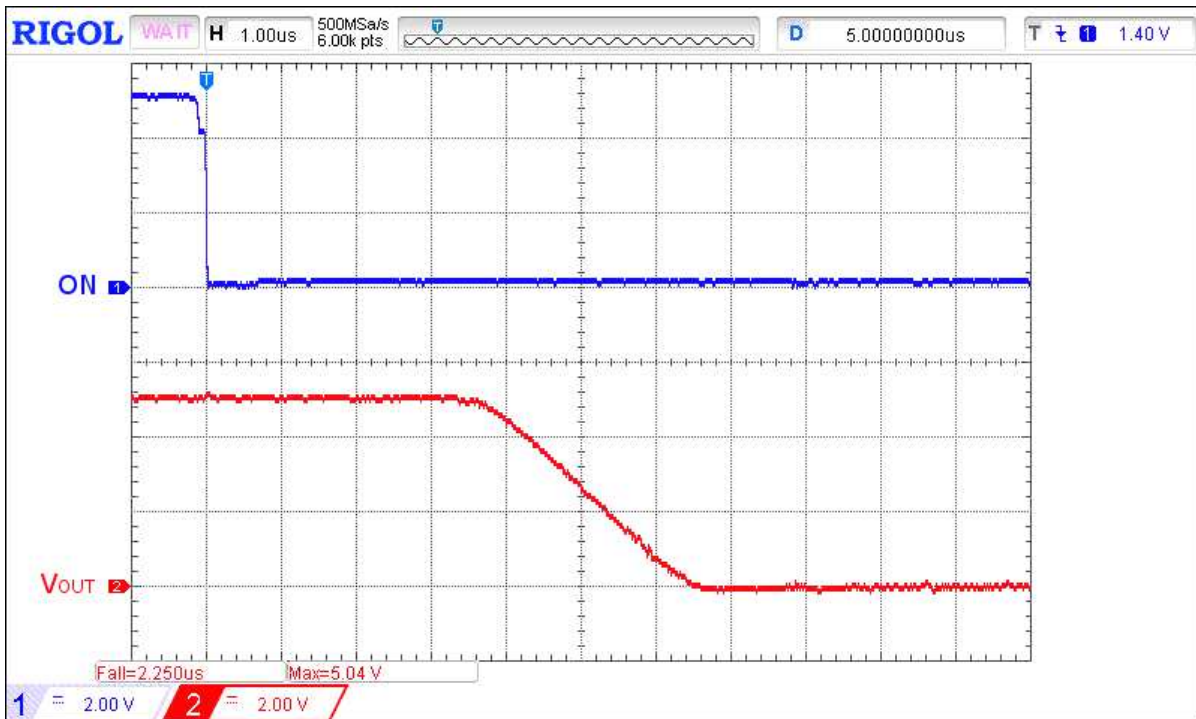

Figure 5. Typical Turn OFF operation waveform for $V_{IN} = 5\text{ V}$, no C_{LOAD} , $R_{LOAD} = 10\ \Omega$

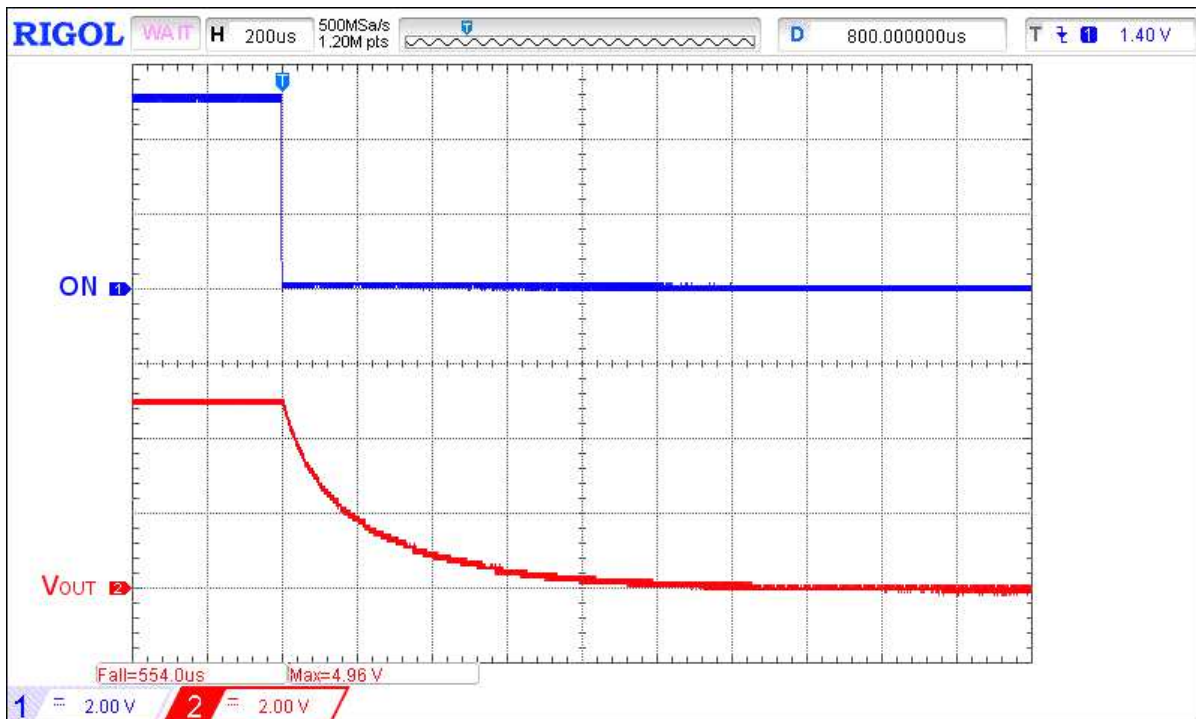

Figure 6. Typical Turn OFF operation waveform for $V_{IN} = 5\text{ V}$, $C_{LOAD} = 30\ \mu\text{F}$, $R_{LOAD} = 10\ \Omega$

SLG59M1736C

An Ultra-small 33 mΩ, 2.2 A pFET
Load Switch with Controlled Inrush Current

Applications Information

SLG59M1736C Nominal Operation

During V_{IN} power-up operation, the SLG59M1736C's internal inrush current Start-up Control circuit is activated once V_{IN} reaches 90% of its nominal voltage (Please see $V_{SUCC(TH)}$ specification). Once V_{IN} has reached this threshold (within the SLG59M1736C's nominal input range of 2.5 V to 5.5 V), the ON pin can be toggled LOW-to-HIGH to close the switch. Nominal power-off sequence is performed in reverse: that is, the ON pin is toggled HIGH-to-LOW to open the switch before V_{IN} is powered down/turned OFF.

SLG59M1736C VIN Inrush Current Limit on Startup

During startup, the current passing through the power FET is internally limited to a maximum specified by I_{RISE} in the EC table. To prevent incomplete start-up, the SLG59M1736C shall be powered up only with a capacitive load C_{LOAD} attached to the VOUT pin. After V_{OUT} ramps up to its nominal voltage, a resistive load (R_{LOAD}) can be applied to the load switch.

Slew Rate Calculation

During the rise of V_{OUT} , the SLG59M1736C limits the output current to I_{RISE} . With a capacitor C_{LOAD} attached to VOUT, the equation below provides the nominal value for the slew rate:

$$\text{Slew Rate} = \frac{I_{RISE}}{C_{LOAD}}$$

Power Dissipation Considerations

The junction temperature of the SLG59M1736C depends on factors such as board layout, ambient temperature, external air flow over the package, load current, and the $R_{DS(ON)}$ -generated voltage drop across each power MOSFET. While the primary contributor to the increase in the junction temperature of the SLG59M1736C is the power dissipation of its power MOSFETs, its power dissipation and the junction temperature in nominal operating mode can be calculated using the following equations:

$$PD_{TOTAL} = R_{DS(ON)} \times I_{DS}^2$$

where:

PD_{TOTAL} = Total package power dissipation, in Watts (W)

$R_{DS(ON)}$ = Power MOSFET ON resistance, in Ohms (Ω)

I_{DS} = Output current, in Amps (A)

and

$$T_J = PD_{TOTAL} \times \theta_{JA} + T_A$$

where:

T_J = Die junction temperature, in Celsius degrees ($^{\circ}\text{C}$)

θ_{JA} = Package thermal resistance, in Celsius degrees per Watt ($^{\circ}\text{C}/\text{W}$) – highly dependent on pcb layout

T_A = Ambient temperature, in Celsius degrees ($^{\circ}\text{C}$)

In nominal operating mode, the SLG59M1736C's power dissipation can also be calculated by taking into account the voltage drop across the switch ($V_{IN} - V_{OUT}$) and the magnitude of the switch's output current (I_{DS}):

$$PD_{TOTAL} = (V_{IN} - V_{OUT}) \times I_{DS} \text{ or}$$

$$PD_{TOTAL} = (V_{IN} - (R_{LOAD} \times I_{DS})) \times I_{DS}$$

where:

PD_{TOTAL} = Total package power dissipation, in Watts (W)

V_{IN} = Switch input Voltage, in Volts (V)

R_{LOAD} = Output Load Resistance, in Ohms (Ω)

I_{DS} = Switch output current, in Amps (A)

V_{OUT} = Switch output voltage, or $R_{LOAD} \times I_{DS}$

SLG59M1736C

An Ultra-small 33 mΩ, 2.2 A pFET Load Switch with Controlled Inrush Current

Layout Guidelines:

1. Since the VIN and VOUT pins dissipate most of the heat generated during high-load current operation, it is highly recommended to make power traces as short, direct, and wide as possible. A good practice is to make power traces with absolute minimum widths of 15 mils (0.381 mm) per Ampere. A representative layout, shown in [Figure 7](#), illustrates proper techniques for heat to transfer as efficiently as possible out of the device;
2. To minimize the effects of parasitic trace inductance on normal operation, it is recommended to connect input C_{IN} and output C_{LOAD} low-ESR capacitors as close as possible to the SLG59M1736C's VIN and VOUT pins;
3. The GND pin should be connected to system analog or power ground plane.

SLG59M1736C Evaluation Board:

A GreenFET Evaluation Board for SLG59M1736C is designed according to the statements above and is illustrated on [Figure 7](#). Please note that evaluation board has D_Sense and S_Sense pads. They cannot carry high currents and dedicated only for RDS_{ON} evaluation.

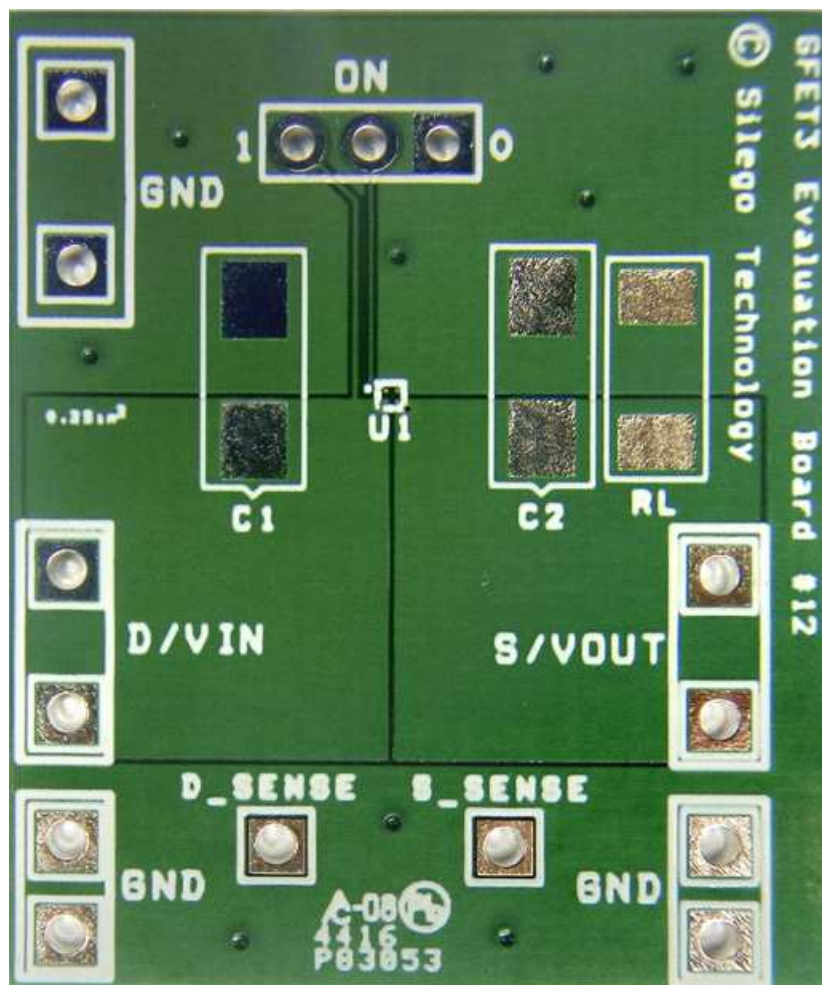

Figure 7. SLG59M1736C Evaluation Board

SLG59M1736C

An Ultra-small 33 mΩ, 2.2 A pFET Load Switch with Controlled Inrush Current

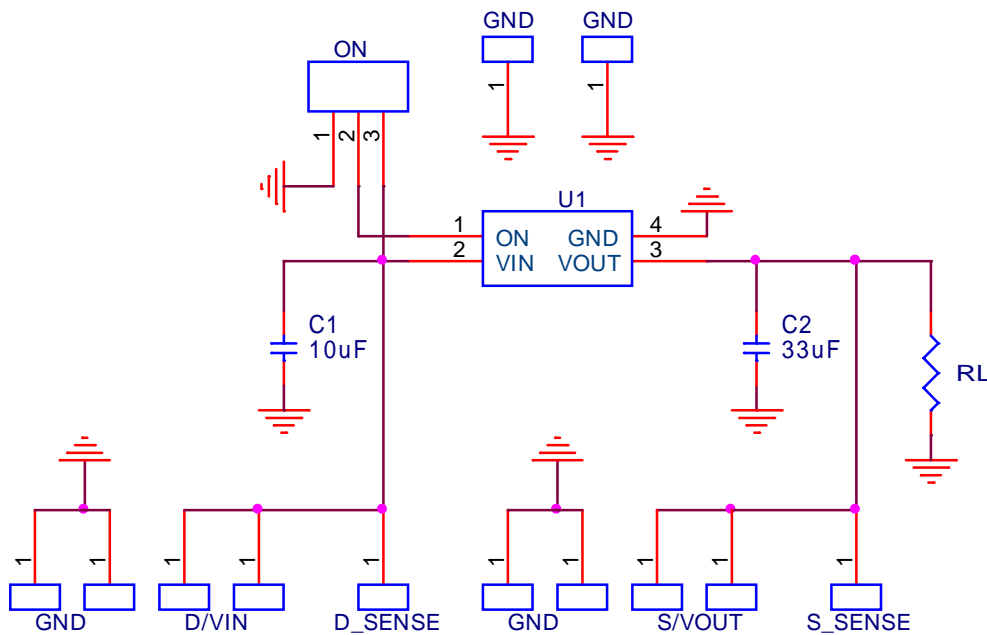

Figure 8. SLG59M1736C Evaluation Board Connection Circuit

Basic Test Setup and Connections

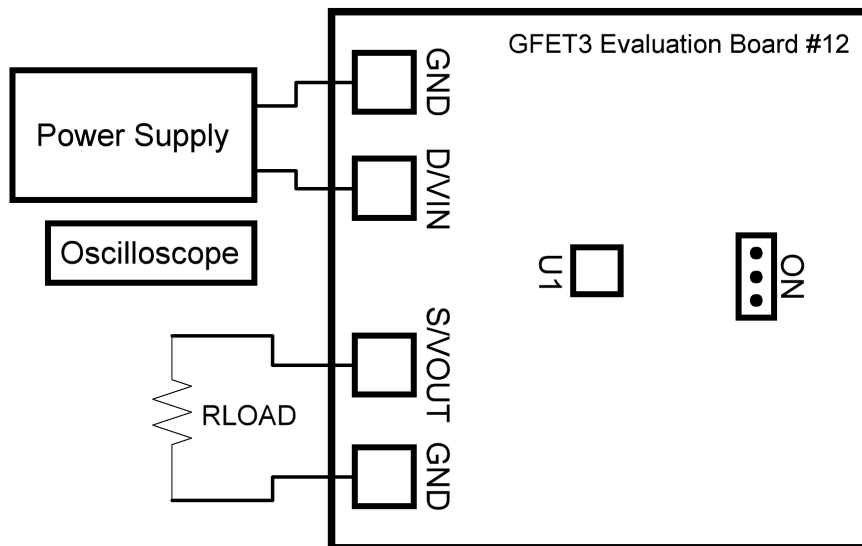

Figure 9. SLG59M1736C Evaluation Board Connection Circuit

EVB Configuration

1. Connect oscilloscope probes to D/VIN, S/VOUT, ON, etc.;
2. Turn on Power Supply and set desired V_{IN} from 2.5 V...5.5 V range;
3. Toggle the ON signal High or Low to observe SLG59M1736C operation.

SLG59M1736C

An Ultra-small 33 mΩ, 2.2 A pFET
Load Switch with Controlled Inrush Current

Package Top Marking System Definition

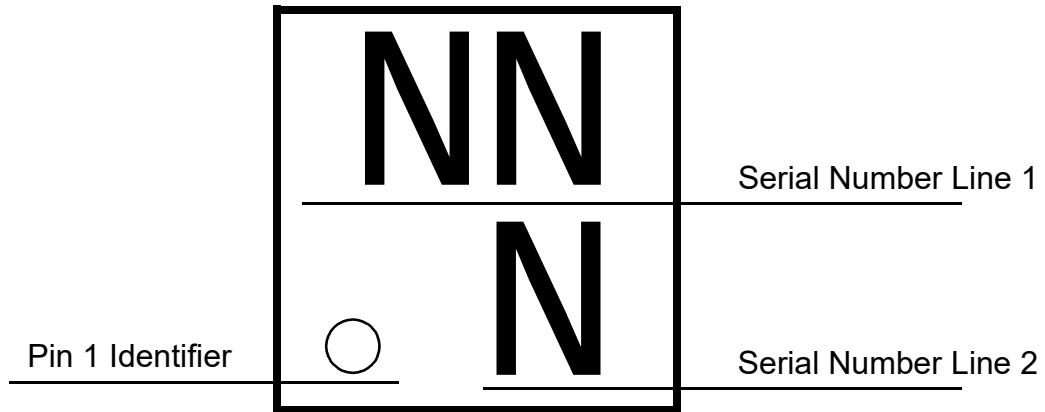

- NN -Part Serial Number Field Line 1
where each “N” character can be A-Z and 0-9
- N -Part Serial Number Field Line 2
where each “N” character can be A-Z and 0-9

SLG59M1736C

An Ultra-small 33 mΩ, 2.2 A pFET
Load Switch with Controlled Inrush Current

Package Drawing and Dimensions

4 Pin WLCSP Green Package 0.8 x 0.8 mm

Laser Marking View

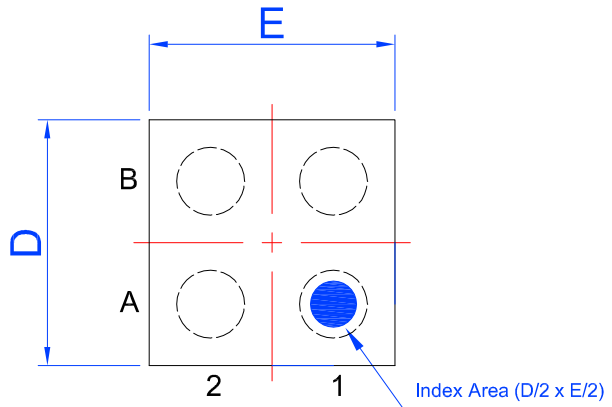

Bump View

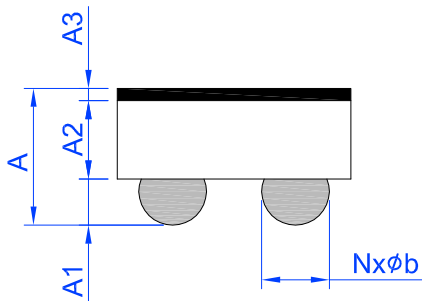
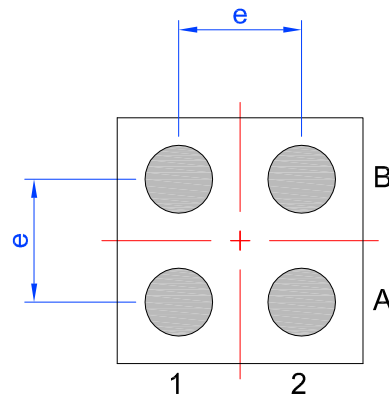

SIDE View

| TERMINALS ASSIGNMENTS | | |
|-----------------------|-----|------|
| B | VIN | VOUT |
| A | ON | GND |
| | 1 | 2 |

Unit: mm

| Symbol | Min | Nom. | Max | Symbol | Min | Nom. | Max |
|--------|-------|-------|-------|--------|----------|------|------|
| A | 0.380 | - | 0.500 | D | 0.77 | 0.80 | 0.83 |
| A1 | 0.125 | 0.150 | 0.175 | E | 0.77 | 0.80 | 0.83 |
| A2 | 0.240 | 0.265 | 0.290 | e | 0.40 BSC | | |
| A3 | 0.015 | 0.025 | 0.035 | N | 4 (Bump) | | |
| b | 0.195 | 0.220 | 0.245 | | | | |

SLG59M1736C

An Ultra-small 33 mΩ, 2.2 A pFET
Load Switch with Controlled Inrush Current

SLG59M1736C 4 Pin WLCSP PCB Landing Pattern

 Exposed Bump
(Laser marking view)

 Recommended
Land Pattern

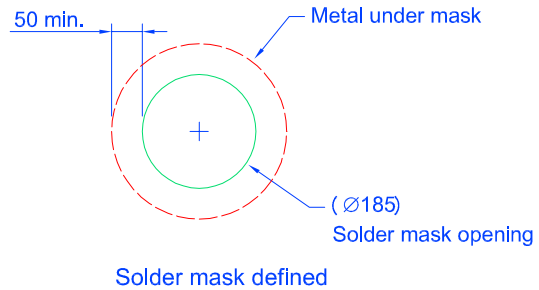
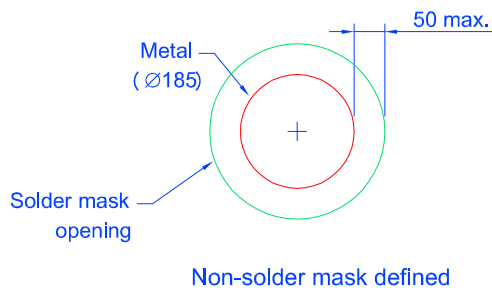
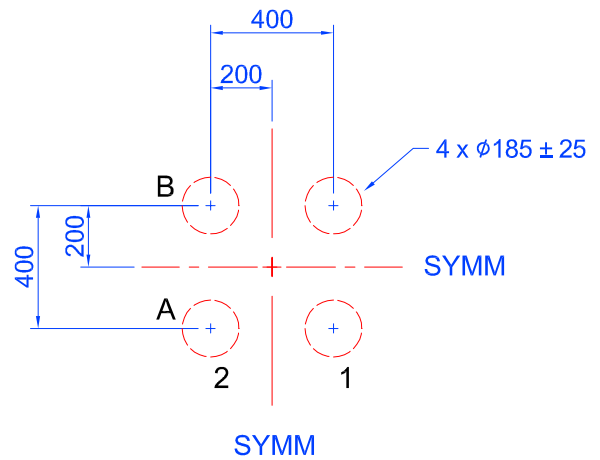
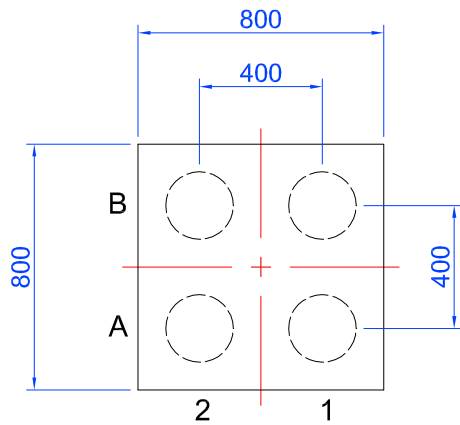

Solder mask detail (not to scale)

Unit: um

SLG59M1736C

An Ultra-small 33 mΩ, 2.2 A pFET
Load Switch with Controlled Inrush Current

Recommended Reflow Soldering Profile

For successful reflow of the SLG59M1736C a recommended thermal profile is illustrated below:

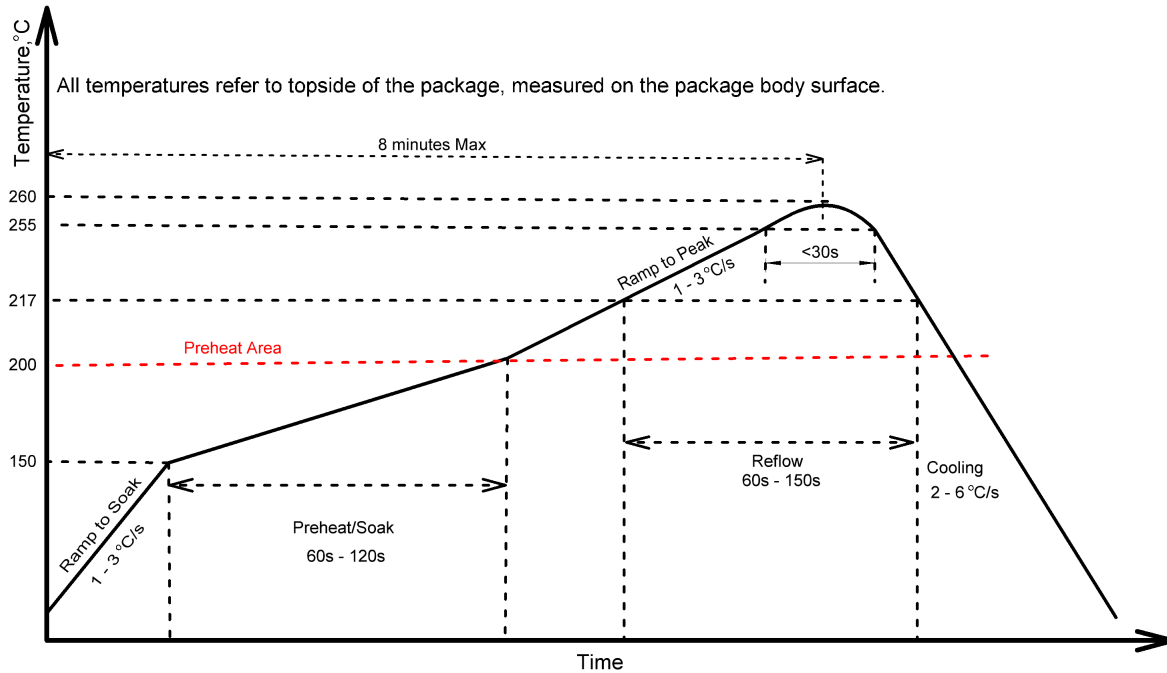

Note: This reflow profile is for classification/preconditioning and are not meant to specify board assembly profile. Actual board assembly profiles should be developed based on specific process needs and board designs and should not exceed parameters depicted on figure above.

Please see more information on IPC/JEDEC J-STD-020: latest revision for reflow profile based on package volume of 0.208 mm³ (nominal).

SLG59M1736C

An Ultra-small 33 mΩ, 2.2 A pFET
Load Switch with Controlled Inrush Current

Tape and Reel Specifications

| Package Type | # of Pins | Nominal Package Size [mm] | Max Units | | Reel & Hub Size [mm] | Leader (min) | | Trailer (min) | | Tape Width [mm] | Part Pitch [mm] |
|--|-----------|---------------------------|-----------|---------|----------------------|--------------|-------------|---------------|-------------|-----------------|-----------------|
| | | | per Reel | per Box | | Pockets | Length [mm] | Pockets | Length [mm] | | |
| WLCSP 4L 0.8 x 0.8 mm 0.4P Green | 4 | 0.8 x 0.8 x 0.44 | 3000 | 3000 | 178/60 | 100 | 400 | 100 | 400 | 8 | 4 |

Carrier Tape Drawing and Dimensions

| Package Type | Pocket BTM Length | Pocket BTM Width | Pocket Depth | Index Hole Pitch | Pocket Pitch | Index Hole Diameter | Index Hole to Tape Edge | Index Hole to Pocket Center | Tape Width | Tape Thickness |
|--------------------------------------|-------------------|------------------|--------------|------------------|--------------|---------------------|-------------------------|-----------------------------|------------|----------------|
| | A0 | B0 | K0 | P0 | P1 | D0 | E | F | W | T |
| WLCSP 4L 0.8x0.8 mm 0.4P Green | 0.87 | 0.87 | 0.56 | 4 | 4 | 1.5 | 1.75 | 3.5 | 8 | 0.2 |

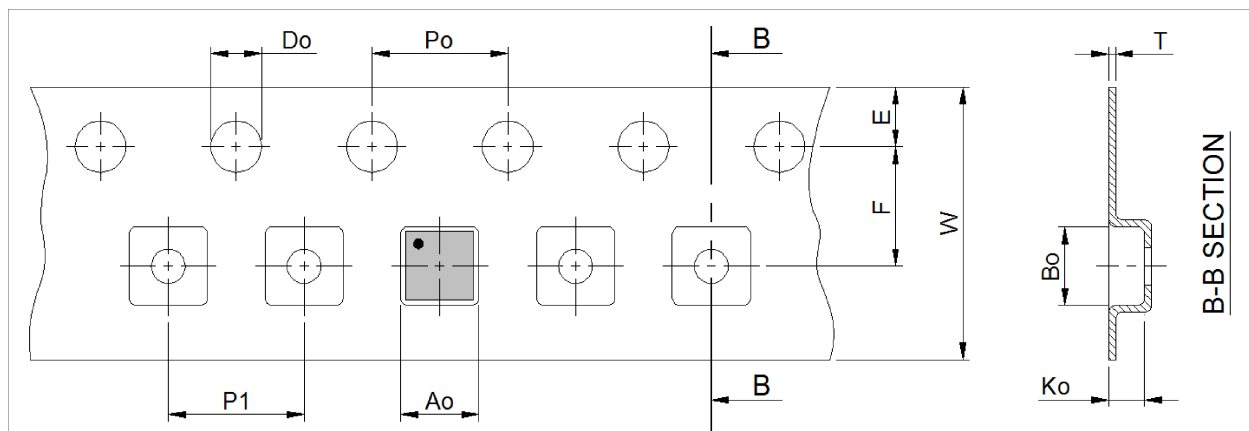

Note: 1.Orientation in carrier: Pin1 is at upper left corner (Quadrant 1).

Refer to EIA-481 specification

SLG59M1736C

An Ultra-small 33 mΩ, 2.2 A pFET
Load Switch with Controlled Inrush Current

Revision History

| Date | Version | Change |
|-----------|---------|--|
| 2/3/2022 | 1.05 | Updated Company name and logo Fixed typos |
| 3/26/2019 | 1.04 | Updated Style and Formatting Corrected Pocket Pitch Spec in Carrier Tape Dimensions Added Layout Guidelines Fixed typos |
| 7/24/2017 | 1.03 | Updated Tape and Reel Specification |
| 5/5/2017 | 1.02 | Updated EC Table |
| 3/28/2017 | 1.01 | Fixed typos Updated PCB Landing Pattern |
| 3/1/2017 | 1.00 | Production Release |

IMPORTANT NOTICE AND DISCLAIMER

RENESAS ELECTRONICS CORPORATION AND ITS SUBSIDIARIES (“RENESAS”) PROVIDES TECHNICAL SPECIFICATIONS AND RELIABILITY DATA (INCLUDING DATASHEETS), DESIGN RESOURCES (INCLUDING REFERENCE DESIGNS), APPLICATION OR OTHER DESIGN ADVICE, WEB TOOLS, SAFETY INFORMATION, AND OTHER RESOURCES “AS IS” AND WITH ALL FAULTS, AND DISCLAIMS ALL WARRANTIES, EXPRESS OR IMPLIED, INCLUDING, WITHOUT LIMITATION, ANY IMPLIED WARRANTIES OF MERCHANTABILITY, FITNESS FOR A PARTICULAR PURPOSE, OR NON-INFRINGEMENT OF THIRD-PARTY INTELLECTUAL PROPERTY RIGHTS.

These resources are intended for developers who are designing with Renesas products. You are solely responsible for (1) selecting the appropriate products for your application, (2) designing, validating, and testing your application, and (3) ensuring your application meets applicable standards, and any other safety, security, or other requirements. These resources are subject to change without notice. Renesas grants you permission to use these resources only to develop an application that uses Renesas products. Other reproduction or use of these resources is strictly prohibited. No license is granted to any other Renesas intellectual property or to any third-party intellectual property. Renesas disclaims responsibility for, and you will fully indemnify Renesas and its representatives against, any claims, damages, costs, losses, or liabilities arising from your use of these resources. Renesas' products are provided only subject to Renesas' Terms and Conditions of Sale or other applicable terms agreed to in writing. No use of any Renesas resources expands or otherwise alters any applicable warranties or warranty disclaimers for these products.

(Disclaimer Rev.1.01)

Corporate Headquarters

TOYOSU FORESIA, 3-2-24 Toyosu,
Koto-ku, Tokyo 135-0061, Japan
www.renesas.com

Trademarks

Renesas and the Renesas logo are trademarks of Renesas Electronics Corporation. All trademarks and registered trademarks are the property of their respective owners.

Contact Information

For further information on a product, technology, the most up-to-date version of a document, or your nearest sales office, please visit www.renesas.com/contact-us/.