

General Description

Dialog SLG7RN45801 is a low power and small form device. The SoC is housed in a 2mm x 3mm STQFN package which is optimal for using with small devices.

Features

- Low Power Consumption
- Pb - Free / RoHS Compliant
- Halogen - Free
- STQFN - 20 Package

Pin Configuration

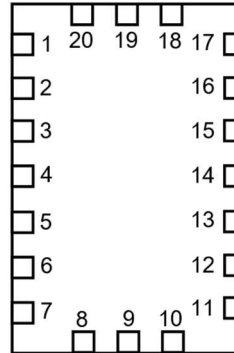

**STQFN-20
(Top View)**

Pin name

Pin #	Pin name	Pin #	Pin name
1	VDD	11	GND
2	NC	12	NC
3	NC	13	NC
4	NC	14	VDD2
5	NC	15	NC
6	NC	16	NC
7	NC	17	NC
8	SCL	18	NC
9	SDA	19	NC
10	NC	20	NC

Block Diagram

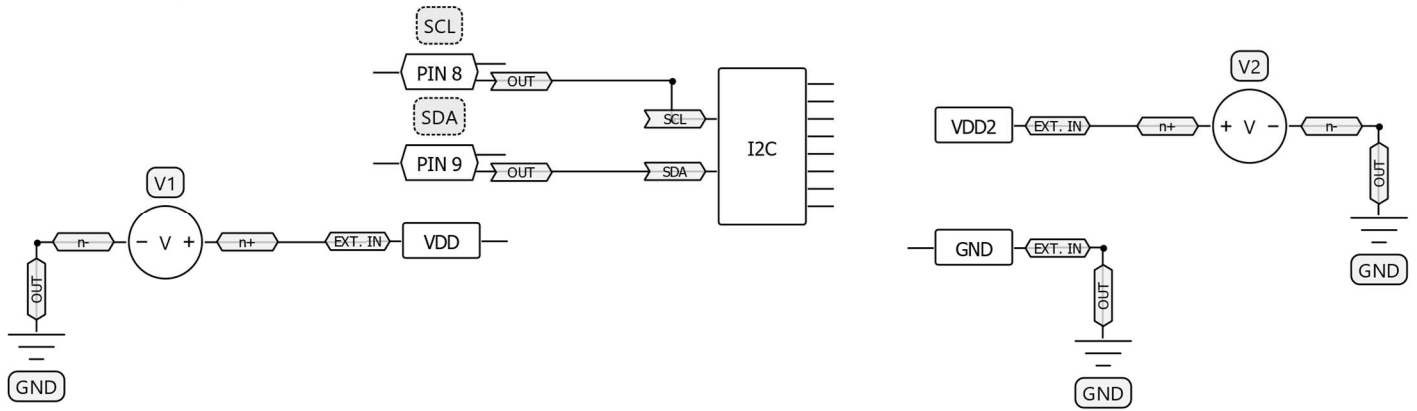

Pin Configuration

Pin #	Pin Name	Type	Pin Description	Internal Resistor
1	VDD	PWR	Supply Voltage	--
2	NC	--	Keep Floating or Connect to GND	--
3	NC	--	Keep Floating or Connect to GND	--
4	NC	--	Keep Floating or Connect to GND	--
5	NC	--	Keep Floating or Connect to GND	--
6	NC	--	Keep Floating or Connect to GND	--
7	NC	--	Keep Floating or Connect to GND	--
8	SCL	Digital Input	Digital Input without Schmitt trigger	floating
9	SDA	Digital Input	Digital Input without Schmitt trigger	floating
10	NC	--	Keep Floating or Connect to GND	--
11	GND	GND	Ground	--
12	NC	--	Keep Floating or Connect to GND	--
13	NC	--	Keep Floating or Connect to GND	--
14	VDD2	PWR	Supply Voltage	--
15	NC	--	Keep Floating or Connect to GND	--
16	NC	--	Keep Floating or Connect to GND	--
17	NC	--	Keep Floating or Connect to GND	--
18	NC	--	Keep Floating or Connect to GND	--
19	NC	--	Keep Floating or Connect to GND	--
20	NC	--	Keep Floating or Connect to GND	--

Ordering Information

Part Number	Package Type
SLG7RN45801V	20-pin STQFN
SLG7RN45801VTR	20-pin STQFN - Tape and Reel (3k units)

Absolute Maximum Conditions

Parameter		Min.	Max.	Unit
Supply Voltage on VDD relative to GND		-0.5	7	V
Supply voltage on VDD2 relative to GND		-0.5	VDD + 0.5	V
DC Input voltage	PINs 2, 3, 4, 5, 6, 7, 8, 9, 10	GND - 0.5	VDD + 0.5	V
	PINs 12, 13, 15, 16, 17, 18, 19, 20		VDD2 + 0.5	
Current at Input Pin		-1.0	1.0	mA
Input leakage (Absolute Value)		--	1000	nA
Storage Temperature Range		-65	150	°C
Junction Temperature		--	150	°C
ESD Protection (Human Body Model)		2000	--	V
ESD Protection (Charged Device Model)		500	--	V
Moisture Sensitivity Level		1		

Electrical Characteristics

Symbol	Parameter	Condition/Note	Min.	Typ.	Max.	Unit
V _{DD}	Supply Voltage		1.71	3.3	5.5	V
V _{DD2}	Supply Voltage		1.71	3.3	5.5	V
T _A	Operating Temperature		-40	25	85	°C
C _{VDD}	Capacitor Value at VDD		--	0.1	--	μF
C _{IN}	Input Capacitance		--	4	--	pF
I _Q	Quiescent Current	Static inputs and floating outputs	--	1	--	μA
V _O	Maximal Voltage Applied to any PIN in High-Impedance State		--	--	VDD	V
I _{VDD}	Maximum Average or DC Current Through VDD Pin (Per chip side, see Note 2)	T _J = 85°C	--	--	45	mA
		T _J = 110°C	--	--	22	mA
I _{GND}	Maximum Average or DC Current Through GND Pin (Per chip side, see Note 2)	T _J = 85°C	--	--	86	mA
		T _J = 110°C	--	--	41	mA
V _{IH}	HIGH-Level Input Voltage PINs 2, 3, 4, 5, 6, 7, 8, 9 and 10	Logic Input at VDD=1.8V	1.06	--	VDD	V
		Logic Input at VDD=3.3V	1.81	--	VDD	V
		Logic Input at VDD=5.0V	2.68	--	VDD	V
V _{IL}	LOW-Level Input Voltage PINs 2, 3, 4, 5, 6, 7, 8, 9 and 10	Logic Input at VDD=1.8V	1.06	--	VDD	V
		Logic Input at VDD=3.3V	1.81	--	VDD	V
		Logic Input at VDD=5.0V	2.68	--	VDD	V
T _{SU}	Startup Time	From VDD rising past P _{ON} THR	0.61	1.24	1.65	ms
P _{ON} THR	Power On Threshold	V _{DD} Level Required to Start Up the Chip	1.41	1.54	1.66	V
P _{OFF} THR	Power Off Threshold	V _{DD} Level Required to Switch Off the Chip	1.00	1.15	1.31	V

Note:

- DC or average current through any pin should not exceed value given in Absolute Maximum Conditions.
- The GreenPAK's power rails are divided in two sides. PINs 2, 3, 4, 5, 6, 7, 8, 9 and 10 are connected to one side, PINs 12, 13, 15, 16, 17, 18, 19, and 20 to another.
- Guaranteed by Design.

I²C Specifications

Symbol	Parameter	Condition/Note	Min.	Typ.	Max.	Unit
F _{SCL}	Clock Frequency, SCL	V _{DD} = (1.71...5.5) V	--	--	400	kHz
t _{LOW}	Clock Pulse Width Low	V _{DD} = (1.71...5.5) V	1300	--	--	ns
t _{HIGH}	Clock Pulse Width High	V _{DD} = (1.71...5.5) V	600	--	--	ns
t _i	Input Filter Spike Suppression (SCL, SDA)	V _{DD} = 1.8V ± 5%	--	--	168	ns
		V _{DD} = 3.3V ± 10%	--	--	157	ns
		V _{DD} = 5.0V ± 10%	--	--	156	ns
t _{AA}	Clock Low to Data Out Valid	V _{DD} = (1.71...5.5) V	--	--	900	ns
t _{BUF}	Bus Free Time between Stop and Start	V _{DD} = (1.71...5.5) V	1300	--	--	ns
t _{HD_STA}	Start Hold Time	V _{DD} = (1.71...5.5) V	600	--	--	ns
t _{SU_STA}	Start Set-up Time	V _{DD} = (1.71...5.5) V	600	--	--	ns
t _{HD_DAT}	Data Hold Time	V _{DD} = (1.71...5.5) V	0	--	--	ns
t _{SU_DAT}	Data Set-up Time	V _{DD} = (1.71...5.5) V	100	--	--	ns
t _R	Inputs Rise Time	V _{DD} = (1.71...5.5) V	--	--	300	ns
t _F	Inputs Fall Time	V _{DD} = (1.71...5.5) V	--	--	300	ns
t _{SU_STO}	Stop Set-up Time	V _{DD} = (1.71...5.5) V	600	--	--	ns
t _{DH}	Data Out Hold Time	V _{DD} = (1.71...5.5) V	50	--	--	ns

Chip address

HEX	BIN	DEC
0x10	0010000	16

I2C Description

1. I2C Basic Command Structure

Each command to the I2C Serial Communications block begins with a Control Byte. The bits inside this Control Byte are shown in Figure 1. After the Start bit, the first four bits are a control code, which can be set by the user in reg<1867:1864>. The Block Address is the next three bits (A10, A9, A8), which will define the most significant bits in the addressing of the data to be read (“1”) or written (“0”) by the command. This Control Byte will be followed by an Acknowledge bit (ACK).

With the exception of the Current Address Read command, all commands will have the Control Byte followed by the Word Address. The Word Address, in conjunction with the three address bits in the Control Byte, will define the specific data byte to be read or written in the command. Figure 1 shows this basic command structure.

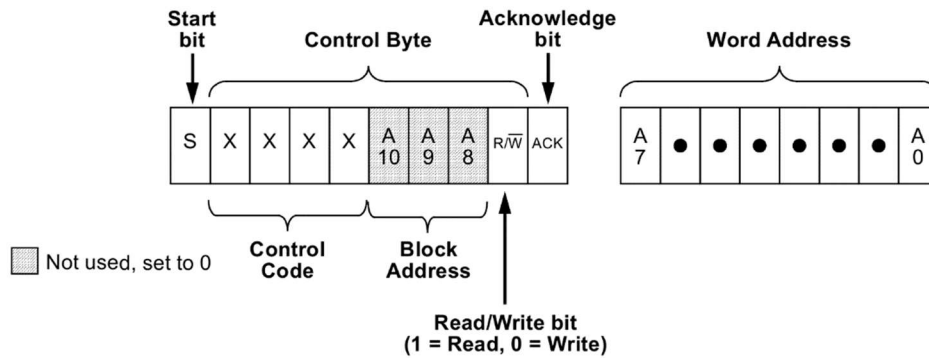

Figure1. I2C Basic Command Structure

2. I2C Serial General Timing

Shown in Figure 2 is the general timing characteristics for the I2C Serial Communications block.

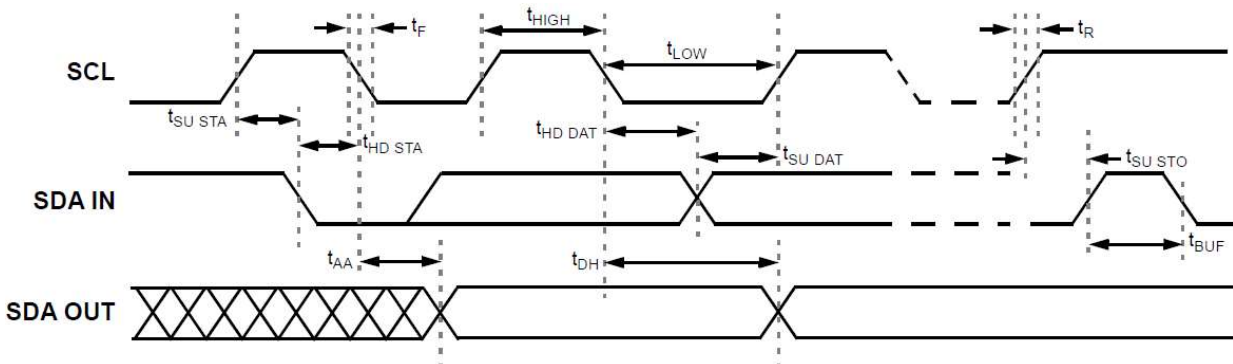

Figure2. I2C Serial General Timing

3. I2C Serial Communications: Read and Write Commands

Following the Start condition from the master, the Control Code [4 bits], the block address [3 bits] and the R/W bit (set to “0”), is placed onto the bus by the Bus Master. After the I2C Serial Communications block has provided an Acknowledge bit (ACK) the next byte transmitted by the master is the Word Address. The Block Address is the next three bits, and is the higher order addressing bits (A10, A9, A8), which when added to the Word Address will together set the internal address pointer in the SLG7RN45801 to the correct data byte to be written. After the SLG7RN45801 sends another Acknowledge bit, the Bus Master will transmit the data byte to be written into the addressed memory location. The SLG7RN45801 again provides an Acknowledge bit and then the Bus Master generates a Stop condition. The internal write cycle for the data will take place at the time that the SLG7RN45801 generates the Acknowledge bit.

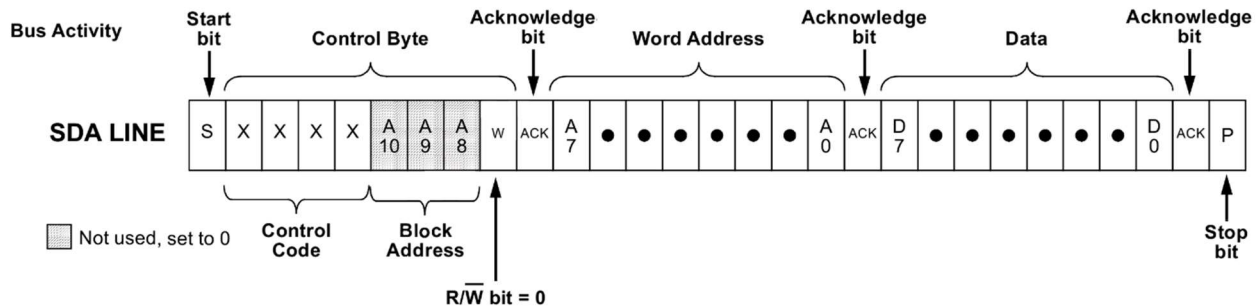

Figure3. I2C Write Command

The Random Read command starts with a Control Byte (with R/W bit set to “0”, indicating a write command) and Word Address to set the internal byte address, followed by a Start bit, and then the Control Byte for the read (exactly the same as the Byte Write command). The Start bit in the middle of the command will halt the decoding of a Write command, but will set the internal address counter in preparation for the second half of the command. After the Start bit, the Bus Master issues a second control byte with the R/W bit set to “1”, after which the SLG7RN45801 issues an Acknowledge bit, followed by the requested eight data bits.

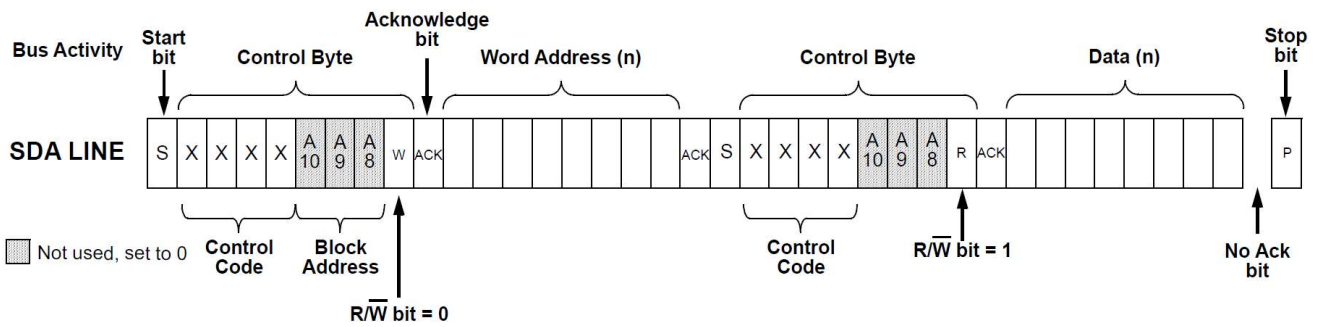

Figure4. I2C Random Read Command

4. I2C register control data

Address Byte	Register Bit	Block	Function
0xF4	reg<1952>	Virtual Input <0>	0 or 1 (VOUT1). Default is 0.
	reg<1953>	Virtual Input <1>	Enable (0) and disable (1) switch1 (VOUT1) Default is 0.
0xC5	reg<1583:1576>	CNT0 Control Data	PWM control data. Default is 0x65. Duty cycle is 0%.
0xC6	reg<1591:1584>		

5. I2C Commands:

1. [start] [0x10] [w] [0xF4] [xxxxxxx(OUT0)] [stop] // OUT0 = 0 or OUT0 = 1.
2. [start] [0x10] [w] [0xF4] [xxxxxxx(OUT1)x] [stop] // OUT1 = 0 or OUT1 = 1.
3. [start] [0x10] [w] [0xF4] [stop] [start] [0x08] [R] [xxxxxxx(OUT1)(OUT0)][stop] // read OUT0 and OUT1 state.
4. [start] [0x10] [w] [0xC5] [xxxxxxx] [xxxxxxx] [stop] // set duty cycle value.

Package Top Marking

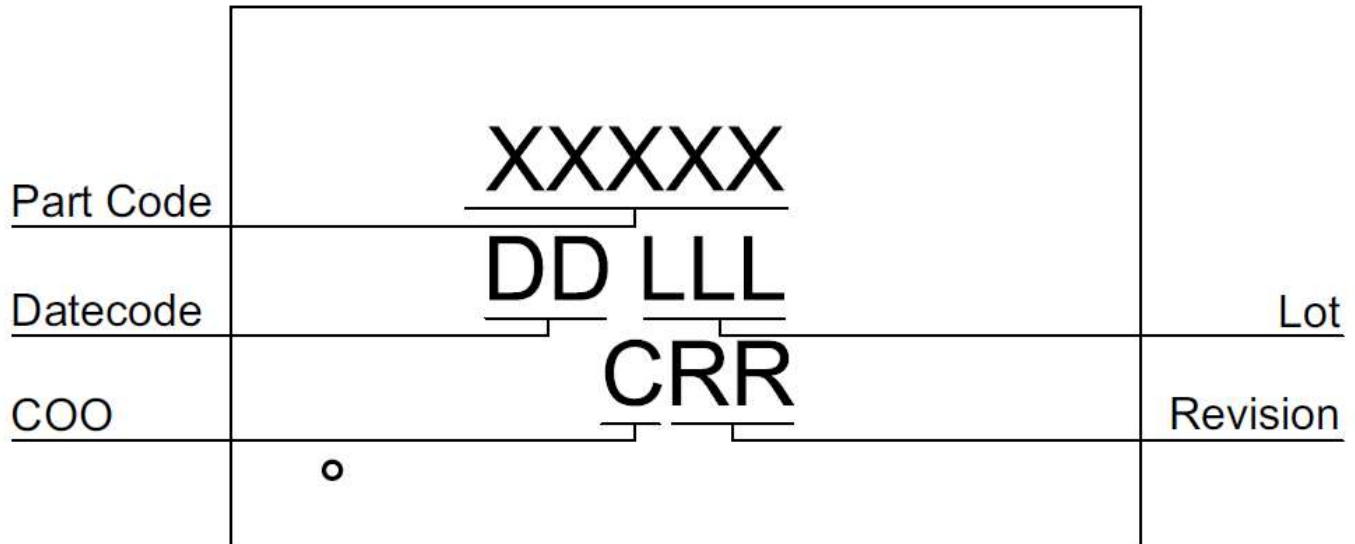

- XXXXX – Part ID Field: identifies the specific device configuration
- DD – Date Code Field: Coded date of manufacture
- LLL – Lot Code: Designates Lot #
- C – Assembly Site/COO: Specifies Assembly Site/Country of Origin
- RR – Revision Code: Device Revision

Datasheet Revision	Programming Code Number	Lock Status	Checksum	Part Code	Revision	Date
0.10	001	U	0x3E3859E0			06/01/2022

Lock coverage for this part is indicated by \surd , from one of the following options:

\surd	Unlocked
	Locked for read, bits <1535:0>
	Locked for write, bits <1535:0>
	Locked for write all bits
	Locked for read and write bits <1535:0>
	Locked for read bits <1535:0> and write of all bits

The IC security bit is locked/set for code security for production unless otherwise specified. The Programming Code Number is not changed based on the choice of locked vs. unlocked status.

Package Drawing and Dimensions

STQFN 20L 2x3mm 0.4P COL Package
JEDEC MO-220

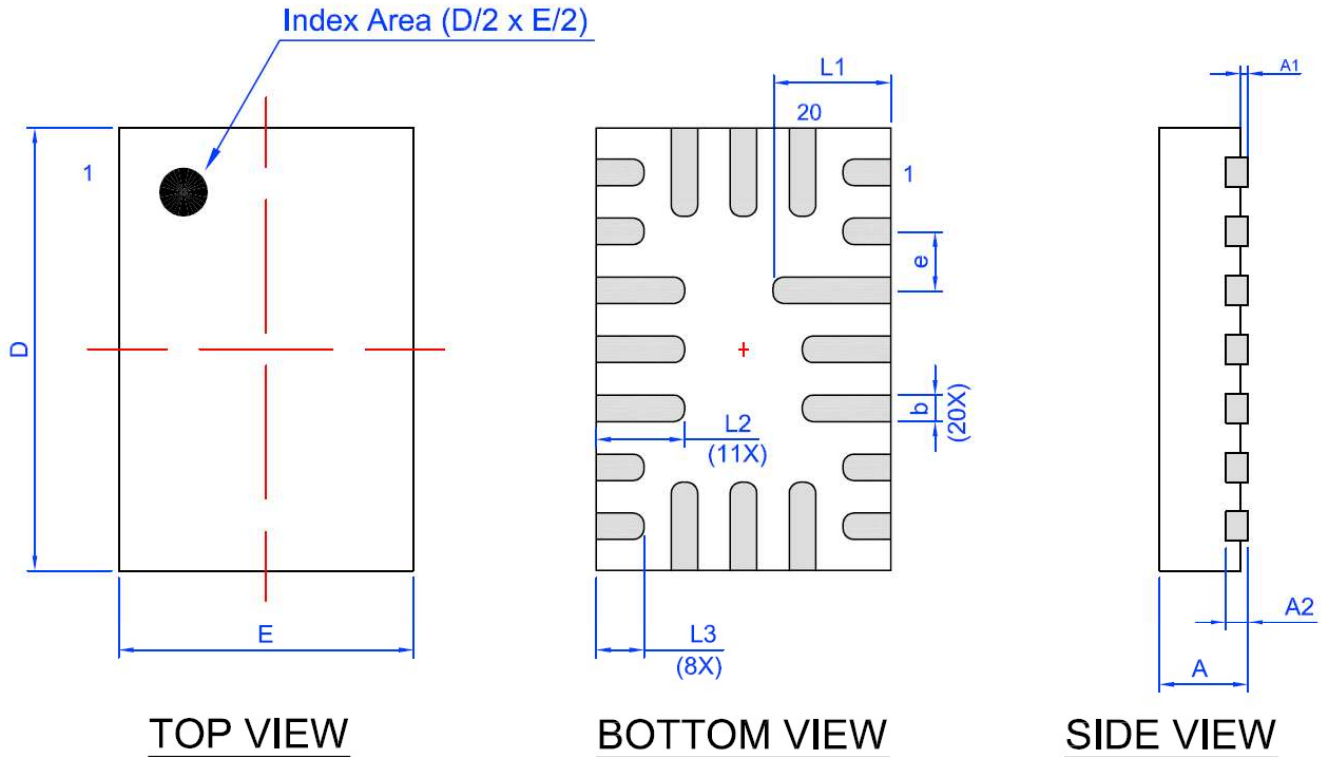

Unit: mm

Symbol	Min	Nom.	Max	Symbol	Min	Nom.	Max
A	0.50	0.55	0.60	D	2.95	3.00	3.05
A1	0.005	-	0.050	E	1.95	2.00	2.05
A2	0.10	0.15	0.20	L1	0.75	0.80	0.85
b	0.13	0.18	0.23	L2	0.55	0.60	0.65
e	0.40 BSC			L3	0.275	0.325	0.375

Tape and Reel Specification

Package Type	# of Pins	Nominal Package Size [mm]	Max Units		Reel & Hub Size [mm]	Leader (min)		Trailer (min)		Tape Width [mm]	Part Pitch [mm]
			per Reel	per Box		Pockets	Length [mm]	Pockets	Length [mm]		
STQFN 20L 2x3mm 0.4P COL	20	2x3x0.55	3000	3000	178/60	100	400	100	400	8	4

Carrier Tape Drawing and Dimensions

Package Type	Pocket BTM Length	Pocket BTM Width	Pocket Depth	Index Hole Pitch	Pocket Pitch	Index Hole Diameter	Index Hole to Tape Edge	Index Hole to Pocket Center	Tape Width
	A0	B0	K0	P0	P1	D0	E	F	W
STQFN 20L 2x3 mm 0.4P COL	2.2	3.15	0.76	4	4	1.5	1.75	3.5	8

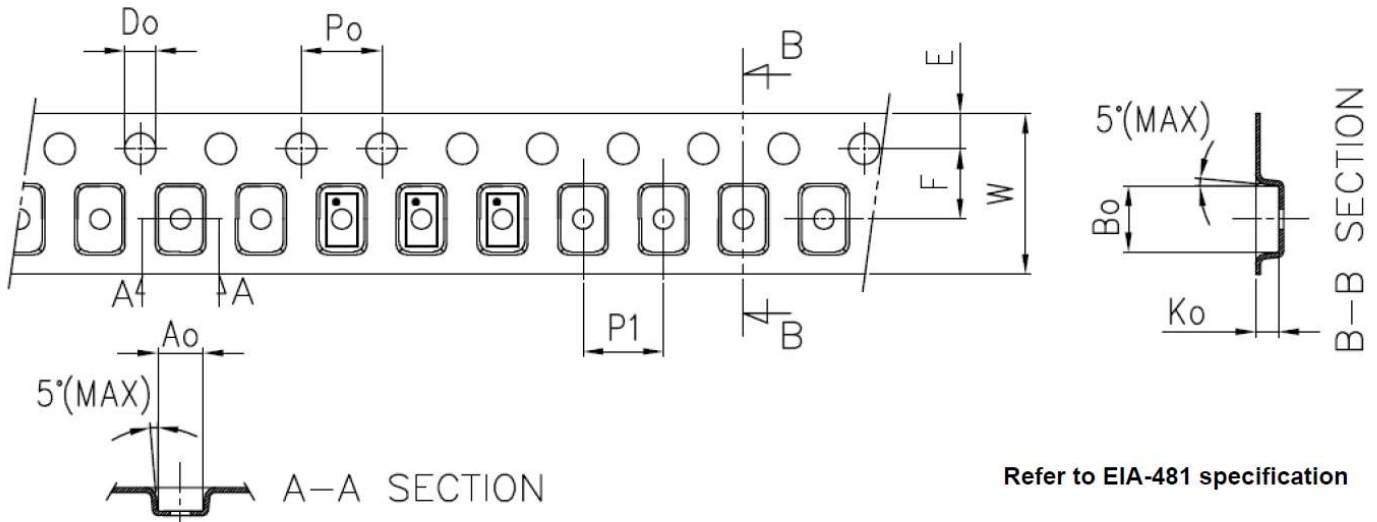

Recommended Reflow Soldering Profile

Please see IPC/JEDEC J-STD-020: latest revision for reflow profile based on package volume of 3.30 mm³ (nominal). More information can be found at www.jedec.org.

Recommended Land Pattern

 Exposed Pad
(Top View)

 Recommended Land Pattern
(Top View)

Units: μm

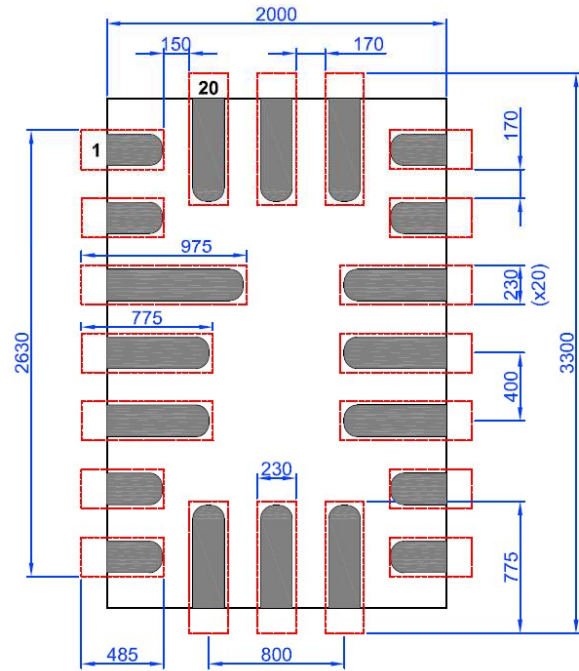
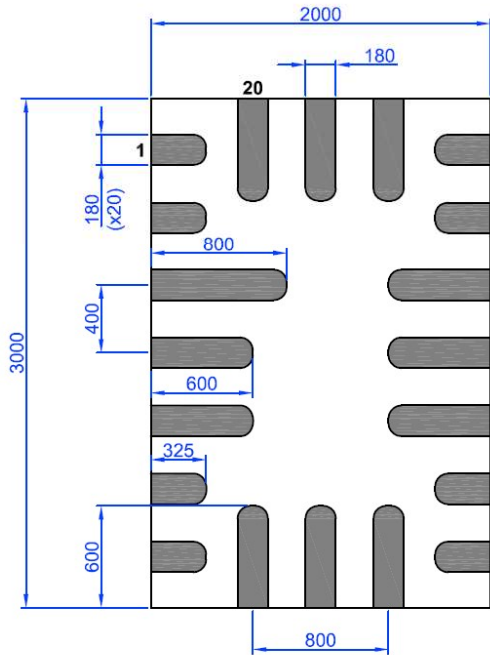

Datasheet Revision History

Date	Version	Change
06/01/2022	0.10	New design for SLG46538V chip

IMPORTANT NOTICE AND DISCLAIMER

RENESAS ELECTRONICS CORPORATION AND ITS SUBSIDIARIES (“RENESAS”) PROVIDES TECHNICAL SPECIFICATIONS AND RELIABILITY DATA (INCLUDING DATASHEETS), DESIGN RESOURCES (INCLUDING REFERENCE DESIGNS), APPLICATION OR OTHER DESIGN ADVICE, WEB TOOLS, SAFETY INFORMATION, AND OTHER RESOURCES “AS IS” AND WITH ALL FAULTS, AND DISCLAIMS ALL WARRANTIES, EXPRESS OR IMPLIED, INCLUDING, WITHOUT LIMITATION, ANY IMPLIED WARRANTIES OF MERCHANTABILITY, FITNESS FOR A PARTICULAR PURPOSE, OR NON-INFRINGEMENT OF THIRD-PARTY INTELLECTUAL PROPERTY RIGHTS.

These resources are intended for developers who are designing with Renesas products. You are solely responsible for (1) selecting the appropriate products for your application, (2) designing, validating, and testing your application, and (3) ensuring your application meets applicable standards, and any other safety, security, or other requirements. These resources are subject to change without notice. Renesas grants you permission to use these resources only to develop an application that uses Renesas products. Other reproduction or use of these resources is strictly prohibited. No license is granted to any other Renesas intellectual property or to any third-party intellectual property. Renesas disclaims responsibility for, and you will fully indemnify Renesas and its representatives against, any claims, damages, costs, losses, or liabilities arising from your use of these resources. Renesas' products are provided only subject to Renesas' Terms and Conditions of Sale or other applicable terms agreed to in writing. No use of any Renesas resources expands or otherwise alters any applicable warranties or warranty disclaimers for these products.

(Disclaimer Rev.1.01 Jan 2024)

Corporate Headquarters

TOYOSU FORESIA, 3-2-24 Toyosu,
Koto-ku, Tokyo 135-0061, Japan
www.renesas.com

Trademarks

Renesas and the Renesas logo are trademarks of Renesas Electronics Corporation. All trademarks and registered trademarks are the property of their respective owners.

Contact Information

For further information on a product, technology, the most up-to-date version of a document, or your nearest sales office, please visit www.renesas.com/contact-us/.