

# The “Smart” in Smart Lighting

Advanced dedicated semiconductor solutions for lighting



# Renesas System Solution for LED Lighting

We are committed to continue providing dedicated ASSP solutions for intelligent LED Lighting systems implementing integrated features to allow:

- > Low power
- > Low BOM cost
- > High Intelligence and Performance



**Lighting ASSPs**

**New!** **RENEASAS RL78**

Product of the Year for 2008 "Smart Lighting Product"

World's 1st MCU with integrated LED drivers

Lighting ASSP

LED ASSP

**Driver ICs**

PFC+LED IC

RENEASAS Driver IC

1-ch LED DRIVER IC

4-ch LED DRIVER IC

**Discrete**

World's No 2 vendor of Optocouplers

RENEASAS PS9305

Optocoupler

World's No 1 Low Power MOSFETs

RENEASAS TO-252ZP

MOSFET

**Lighting Communications**

Active member of DALI consortium **DALI**

Active member of ZigBee Alliance

World's most robust PLC solution

RENEASAS M150155

Powerline

ZigBee Pro

Lighting Dedicated Protocol Support

**RDM**

DMX-512.com **VLC**

Renesas is an active member of the relevant major consortiums



# Architectural & Entertainment Lighting

High level of colour mixing and flashing sequences

## μPD78F802x – LED ASSP

The world's first microcontroller with integrated 4-channel LED drivers



### High Integration

- > 8-bit microcontroller with integrated 4 channels of LED drivers in a single package reducing PCB space and system cost
- > Dedicated peripherals enable driving LED's with no CPU involvement and minimum BOM
- > Built-in specialised protection and soft-start circuits

### High Intelligence

- > Independent flashing sequences and dimming in each of all 4 channels
- > Thermal management
- > DMX512 and RDM communications

### High Efficiency

- > 1 MHz switching frequency by internal oscillator
- Reduced inductor size in each LED channel

### High Flexibility

- > Up to 1.5 A drive per channel
- > Step-up (boost) or step-down (buck) topologies supported
- > Programmable 32 K Flash microcontroller with up to 1 KB of SRAM, CSI, I<sup>2</sup>C, UART serial interfaces and 4 channel 10-bit ADCs

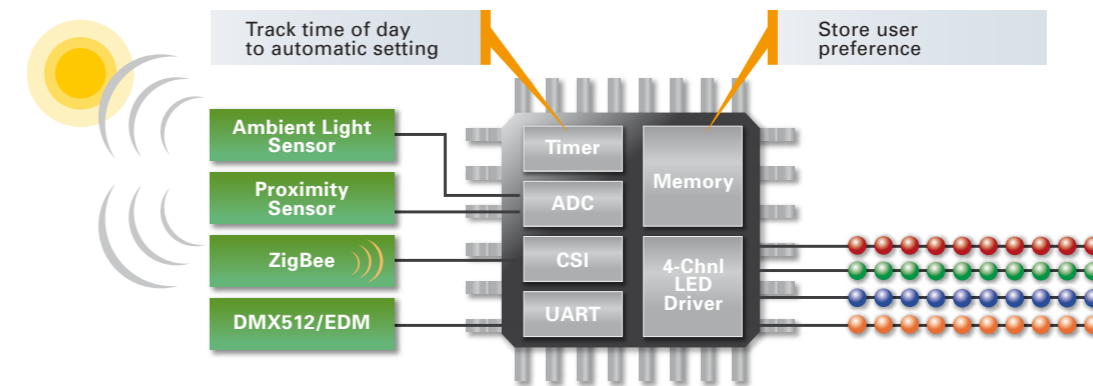

And also for CRI & dimming resolution improvements...



**μPD168804**  
4-channel high-current LED driver IC



**μPD168830**  
Single-channel high-current LED driver IC

# AC Powered Single-channel LED Drivers with PFC

Low cost single chip solution for PFC and LED control with DALI

## 78K0/Ix2 – Lighting ASSP

Award winning single chip solution with 14 variants for driving LEDs & PFC control



### Constant Current Control

- > Low cost solution to drive 1-4 channels HB-LEDs directly with constant current controlled by advanced internal architecture of the 78K0/Ix2 MCU

### PFC Control

- > Critical Conduction Mode PFC control only using the internal peripherals

### High Efficiency

- > 16-bit PWM timers running at 40MHz generate up to 4 PWM outputs

### Dimming

- > PWM and current dimming

### Lighting Communications

- > Integrated DALI, DMX512, RDM

### Low Power: 0.3µA in STOP mode

### Flexible input voltage range

### Protection and PWM emergency shut down

### Temperature support up to 105°

- > 4 channels of 40 MHz 16-bit PWM outputs
- > Integrated high and low speed oscillators
- > Integrated Manchester code generator for DALI
- > Enhanced analogue capabilities
  - 10 channels of 10-bit ADC
  - 3 comparator channels
  - Op-amp
- > Advanced internal architecture
  - Comparators interlocked with PWM timers
  - ADC's synchronised with PWM timers
  - Op-Amp interconnected with ADC's
- > Communications
  - DALI, DMX, RDM, I<sup>2</sup>C, SPI

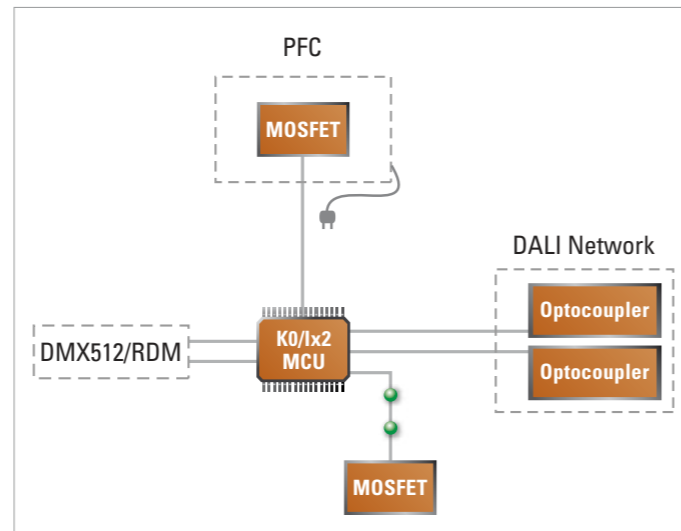

# The Ultimate Lighting Intelligence

High intelligence & efficiency for LED Drivers with DALI

## RL78/I1A – New Lighting ASSP!

Makes the future of lighting a reality



### Constant Current Control

- > 64 MHz 16-bit PWM timers generate up to 6 outputs
- > 11 channels of ADCs interlocked with PWM timers
- > Fast PI Processing in HW with integrated MAC
- > Integrated Dithering function allows 0.97 nS resolution
- > Integrated soft-start function

### Survival Capabilities

#### Over-current Protection

Integrated 6 channel analogue comparators interlocked with PWM timers for immediate HW reaction

#### Thermal Management

Integrated temperature sensor

#### High Temperatures Support

Guaranteed operation at up to 125°

### PFC Control

- > Critical Conduction Mode
- > Continuous Conduction Mode
- > Discontinuous Conduction Mode
- > Digital Interleaved PFC control supported

### Fine Dimming

6 channels of integrated 16-bit PWM timer gating function provides individual 16-bit dimming for each LED channel

### Extended DALI

Selectable 16, 17, 24 bit frame for reception and 8, 16, 24 bit frame for transmission of DALI communications supported on chip. DMX512 and RDM also supported

## Based on Renesas' brand new 16-bit core RL78

### High Performance CPU

32 MHz with 3-stage pipeline  
40.6 DMIPS @32MHz

### Lowest Power

66 µA/MHz  
Snooze Mode: < 1 µA standby with DALI  
0.2 µA in STOP mode  
32 MHz Integrated Oscillator +-1% accuracy  
4 KB Data Flash supporting background operation  
Integrated HW Multiplier/Divider and MAC



### Integrated Safety Functions

- > Flash Memory CRC Calculation
- > RAM Parity Bit Error Detection
- > Illegal Access Detection
- > RAM/SFR Guard Protection
- > Clock Frequency Detection
- > A/D Test Function – IEC60730 compliance

# LED Retrofit Lamps

Reducing the cost and increasing efficiency of AC powered LED retrofit lamps

## R2A2013X PFC LED Driver IC

a dedicated solution for LED retrofit bulbs and tubes

### High Integration

PWM and TRIAC dimming  
Thermal Shutdown Function  
Over-current protection and more...

### Reduced BOM cost

High-side step-down control  
Allows using low voltage MOSFETs with high speed switching

### Isolation

Supports both, Isolation and Non-isolation type of applications while PFC is still supported



### High efficiency of 92%

Reduced switching losses using Critical Conduction Mode with Zero Current Switching and low voltage MOSFETs

### High Power Factor of over 0.9

Integrated Power Factor improvement control function  
High system efficiency  
Reduced EMI  
Regulations compliance

## Design flexibility & common platform approach – design for various LED bulb types using the same driver IC

### Topology

- > High-side step-down
- > Low-side buck-boost
- > Low side step down
- > High-side buck-boost
- > Flyback topology
- > Peak current
- > Average current
- > Constant input-power control

### Flexibility

Adjustable frequency 25 KHz - 250 KHz  
Wide choice of inductors for the application  
BOM cost reduction accordingly  
Fixed and variable frequency switching allowing CRM and Peak current control  
Integrated over voltage protection  
High temperature support of up to 150°C  
Small package: SOP-8

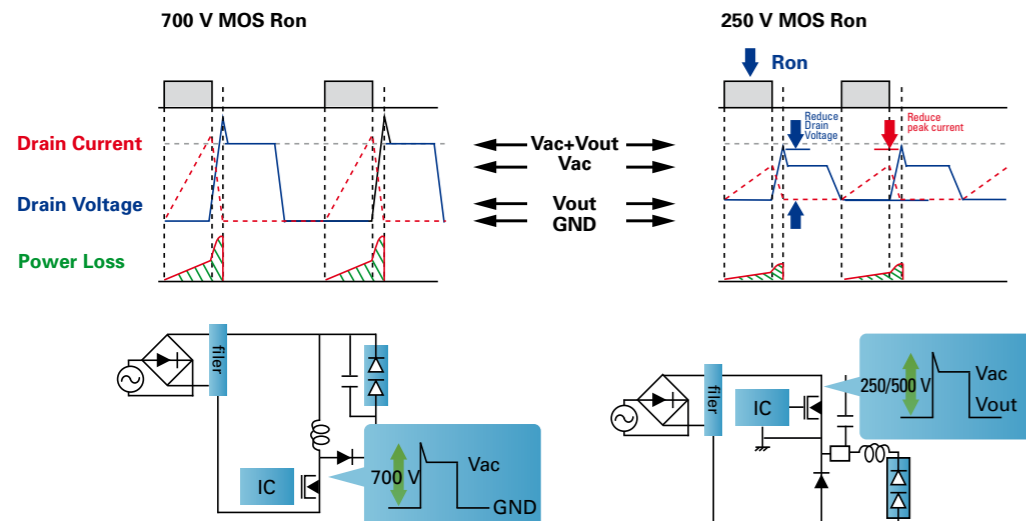

Common low-side buck-boost control

High-side step-down control

# Isolation in lighting

High performance Optocouplers to match any type of lighting system requirements



### Features

- > Renesas is the World's No 1 supplier of standard optocouplers
- > High isolation for high and low voltages with safety certification
- > High quality and reliability – less than 5ppm
- > 8mm creepage
- > World's smallest package for space saving isolation - (SOP4, SOP5, SO8, SSOP, DIP, Flat-Lead, Ultra SSOP)
- > High temperatures support of up to 110°

### Applications

- > Isolation specified by DALI communications protocol
- > Power supply stage isolation in mains-powered LED drivers
- > Isolation for a lighting control system from LED drivers
- > Isolation for mains failure or battery failure detection in emergency lighting applications

Huge range of standard optocouplers for isolation and high-speed optocouplers for communications available at: [www.renesas.eu/opto](http://www.renesas.eu/opto)

## Switching mode constant current and dimming control



### MOSFET's for LED lighting

- > Renesas is the World's No 1 low voltage Power MOSFET supplier
- > Wide range of supported currents up to 180 A
- > Minimum switching losses
- > AEC-Q101 qualified on selected devices
- > RoHS compliant
- > Up to T<sub>chmax</sub> = 175° on selected devices
- > Lowest R<sub>dson</sub>
- > Wide range of package options
- > Quality and reliability
- > Logic level drive available for selected devices

Huge range of single & dual N- / P- / Complimentary Power MOSFET's available at: [www.renesas.eu/mosfet](http://www.renesas.eu/mosfet)

# Add intelligence with lighting communications

- > Renesas is an active member of the DALI AG
- > DALI communications protocol supported by Applilet EZ application code generator, dedicated graphics-based design tool
- > DALI application notes and source code also available at [www.renesas.eu/lighting](http://www.renesas.eu/lighting)

- > DMX512 and RDM communications protocol supported by Applilet EZ application code generator, dedicated graphics-based design tool
- > Application notes and source code also available at [www.renesas.eu/lighting](http://www.renesas.eu/lighting)

- > Renesas is a founding member of ZigBee™ Alliance
- > Variety of complete hardware & software ZigBee™ Professional certified platforms including single-chip and flex multi-chip solutions
- > Supporting the ZigBee™ Professional Smart Energy and Home Automation profiles with dedicated functions for lighting (e.g. clusters for turning lights on and off or setting light dimming levels)

- > Offering World's most robust single-chip DCSK Powerline Modem supporting global standards
- > Configurable to support worldwide standards
- > Integrates Analog Front End functions

- > Offering smart interoperability in Building Automation with certified KNX stack for RL78 and a hardware demo for evaluation



**DMX-512.com**  
**RDM**



# DALI Wireless Networking

Lighting wireless communications make easy DALI adoption

Easy & robust DALI connectivity through walls, glass, floors and across buildings with high performance wireless mesh technology

## Key Features

- > Supports all DALI commands
- > Penetration through obstacles.
- > Easy implementation & maintenance
- > Plug n' Play: adding, removing and moving lamps & switches on the go
- > Fast response – low latency
- > Cost efficient with ISM/SRD frequency bands
- > Low Power and high range & mobility
- > Flexible configuration
- > Up to 64 wireless DALI nodes
- > Up to 64 DALI devices per wireless DALI node



**RL78/I1A**

enables expanding DALI with wireless mesh networking

## Wireless DALI Demonstration Kit

- > Wireless mesh gateway
- > 8 wireless mesh nodes, each drives 3 channels of LEDs or 1 DALI loop
- > LEDs and DALI devices controlled by the DALI master GUI

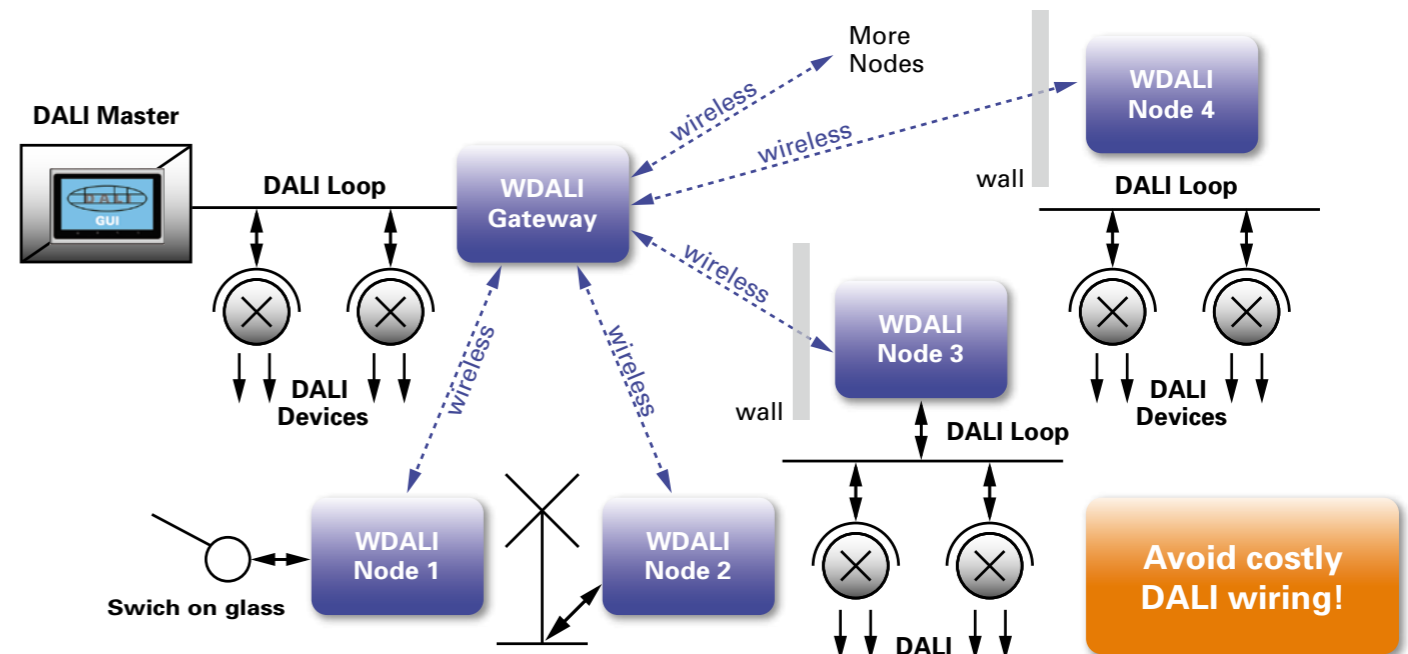

# Dedicated Lighting GUI tools

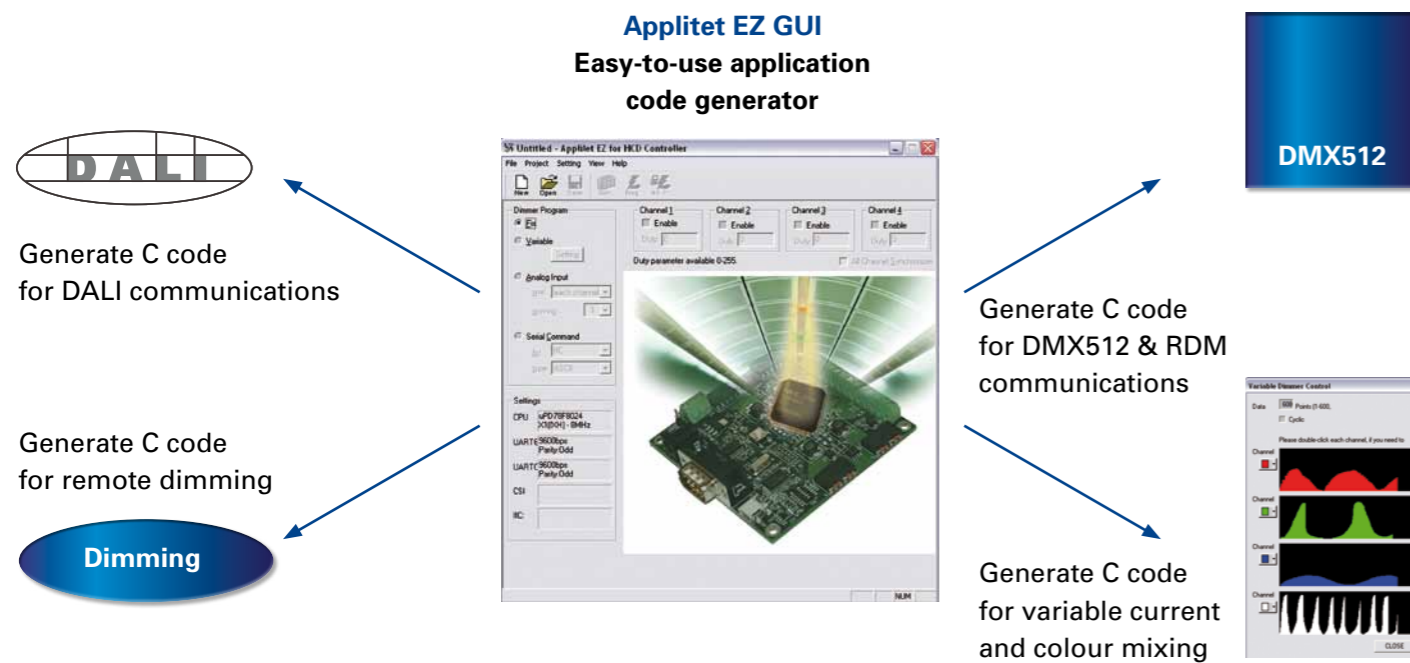

Graphically configure your LED lighting system and automatically generate code for Renesas Lighting microcontrollers (ASSPs).

And also dedicated GUI tools for Lighting Communications. Easy design of lighting scenes, features and controls using either DALI or DMX512 interfaces.

## DALI Master GUI Controller tool



- > Real time control of light output
- > Power & on/off control, dimming control, max/min dimming setting
- > Scene design & fade settings
- > All done by easy graphical configuration

## DMX512 Master GUI Controller tool

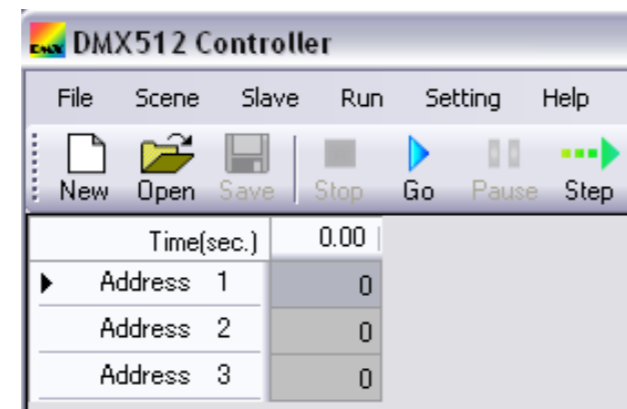

- > Easy learning and implementation of DMX512 protocol
- > Graphics-based design of colour mix, scenes and flashing sequences
- > When the scene is designed, either step through or run in real time for easy debugging

# Dedicated Lighting GUI tools

Confidence in designing your lighting system with Renesas Electronics

## Demonstration kits

- RL78/I1A DC/DC LED Control**  
Based on the RL78/I1A  
3 channels of LEDs  
DALI & DMX supported  
Order Code XXXXXXXXX
- 78K0/Ix2 LED Control**  
Using the lighting ASSP to drive 3 channels of HB-LEDs with DALI & DMX512  
Order Code XXXXXXXXX
- Lighting Communication**  
DALI & DMX master communications with GUI  
Order Code XXXXXXXXX
- Shine It!**  
Using the  $\mu$ PD78F8024 LED ASSP to drive 4 channels of RGBW HB-LEDs with DMX512  
Order Code XXXXXXXXX

## Reference designs

- LED retrofit bulb for Isolated and non-isolated designs with PFC. Based on PFC IC RA20134
- 85-277VAC Triac dimmable single channel LED driver with PFC based on 78K0/Ix2 Lighting ASSP
- AC powered 3 ch LED driver with PFC based on 78K0/Ix2 Lighting ASSP

# VLC – Visible Light Communications

RL78/I1A based demo

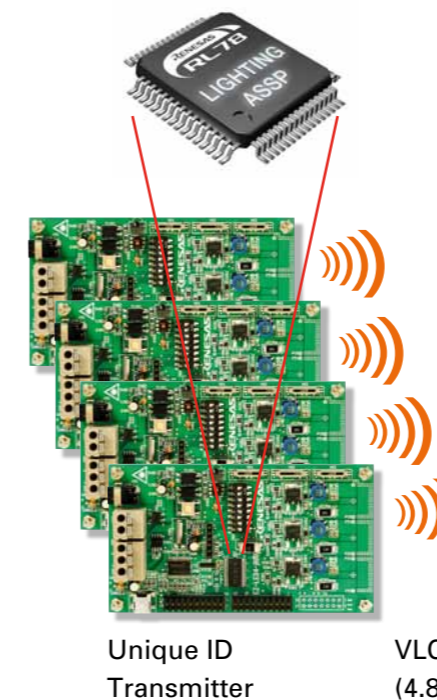

## Features

- > Communication without light flickering
- > No ambient light interference
- > Use lights everywhere
- > No EMI/EMS, no human health impact
- > No conflicts with Radio-restricted areas

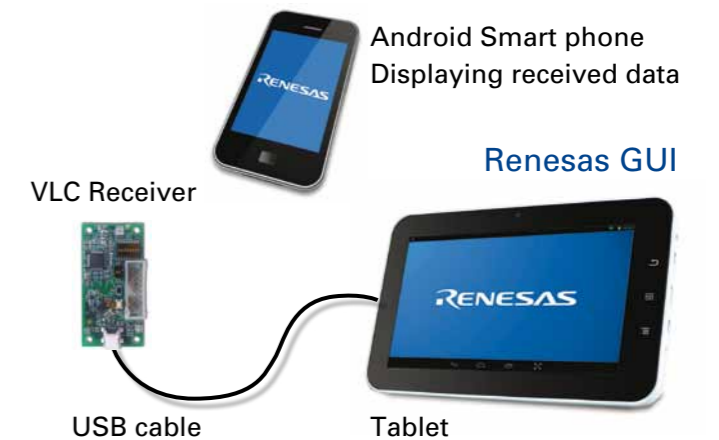

# Application notes & Source codes

Technology	Description	Document Number
RL78/I1A	Lighting Communications Using RL78/I1A	R01AN1115EJ0100
RL78/I1A	LED Control Using RL78/I1A	R01AN1087EJ0100
RL78/I1A	LED Control Using RL78/I1A Timer KB Special Functions	R01AN1382EG0100
78K0/lx2	LED Lighting System with PFC Control	R01AN0674EJ0100
78K0/lx2	DMX512	U19885EE1V0AN00
78K0/lx2	Using integrated DALI function	U19884EE1V0AN00
78K0/lx2	High Brightness LED Control	U19666EJ1V0AN00
78K0/lx2	Fluorescent Ballast Control	U19665EJ2V0AN00
78K0/lx2	Triac Dimmable LED Drive Design	R01AN0520EU0100
78K0/Kx1	Software Controlled DALI	U17333EE1V0AN00

## The Renesas Eco System

Online technical community



[www.renesasrulz.com](http://www.renesasrulz.com)

3rd Party network



[www.renesas.eu/alliance](http://www.renesas.eu/alliance)

Personalised news & services



[www.renesas.eu/myrenesas](http://www.renesas.eu/myrenesas)

Online technical training



[www.renesasinteractive.com](http://www.renesasinteractive.com)

Facebook group



[www.facebook.com/renesaseurope](http://www.facebook.com/renesaseurope)

Latest news



[www.twitter.com/renesas\\_europe](http://www.twitter.com/renesas_europe)

Renesas Presents video channel



[www.youtube.com/renesaspresents](http://www.youtube.com/renesaspresents)

---

Before purchasing or using any Renesas Electronics products listed herein, please refer to the latest product manual and/or data sheet in advance.

---

**RENESAS**

