

# Battery Fuel Gauge IC Functional Safety

Prepare the useful documents for Li-ion Battery Management Systems

## Abstract

In recent years, the concept and adoption of "Functional Safety" has spread through industrial and consumer equipment to improve safety and reliability. The implementation of functional safety is also accelerating in devices that use Li-ion batteries. Functional safety is standardized in international standards such as IEC61508, etc. Functional safety systems must be designed to these standards and undergo certification tests and audits by qualified teams. Renesas has prepared Battery Fuel Gauge IC(FGIC) products and solutions to aid our customers' battery management related functional safety system design.

## What is Functional Safety?

There are two concepts in "safety design" to reduce risk: intrinsic safety and functional safety. Intrinsic safety is a concept related to the basic operation of a system that achieves the intended operation, and intrinsic safety is achieved by eliminating risk at the source. Ideally, all risks should be eliminated by design. But, in reality, it is often impossible to develop the required systems to this level. The concept of functional safety is to reduce the remaining risk to an acceptable level by adding protective functions to systems.

Functional safety defines application specific risks, and the requirements to minimize these via the control system for specific end applications. Functional Safety is based on the premise that things break and fail, perfect software is impossible, and people make mistakes. Functional safety's objective is to keep these risks (residual risks that cannot be eliminated at the design stage) to people, equipment, property, and the environment below acceptable limits through "functionality".

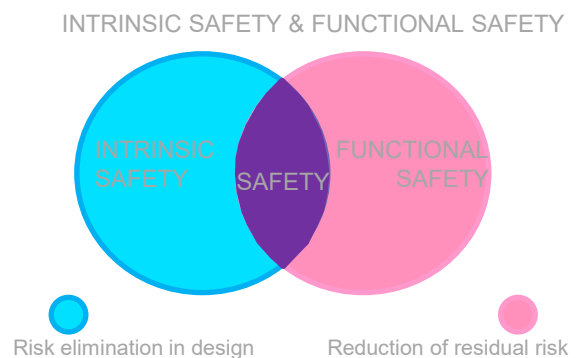

## Functional Safety for Li ion Battery

In recent years, Li-ion batteries have been used in a variety of applications, including power tools, e-bikes, and cleaners. Li-ion batteries have inherent risks, for example overheating and ignition due to over-charging, over-discharging, over-heating, etc. Strict, standardized safety management is required. The standards required for Li-ion battery-powered equipment depend on the application and technology of the system.

Examples) Power Tools:EN62841, E-Bikes:EN15194, Cleaners (Home Appliances):IEC/UL60730  
Risks are assessed according to these standards, and items identified as risks related to Li-ion batteries are listed. The following are examples of risks that need to be addressed in relation to battery packs and battery usage that are commonly considered.

Examples of risks for Li ion battery :

- Over-charging beyond the maximum charge voltage
- Abnormal heating, ignition

**Support for Functional Safety System Design by FGIC**

Renesas FGIC : RAJ240090,RAJ240100 have various protection and self-diagnostic functions to support compliance with functional safety standards.

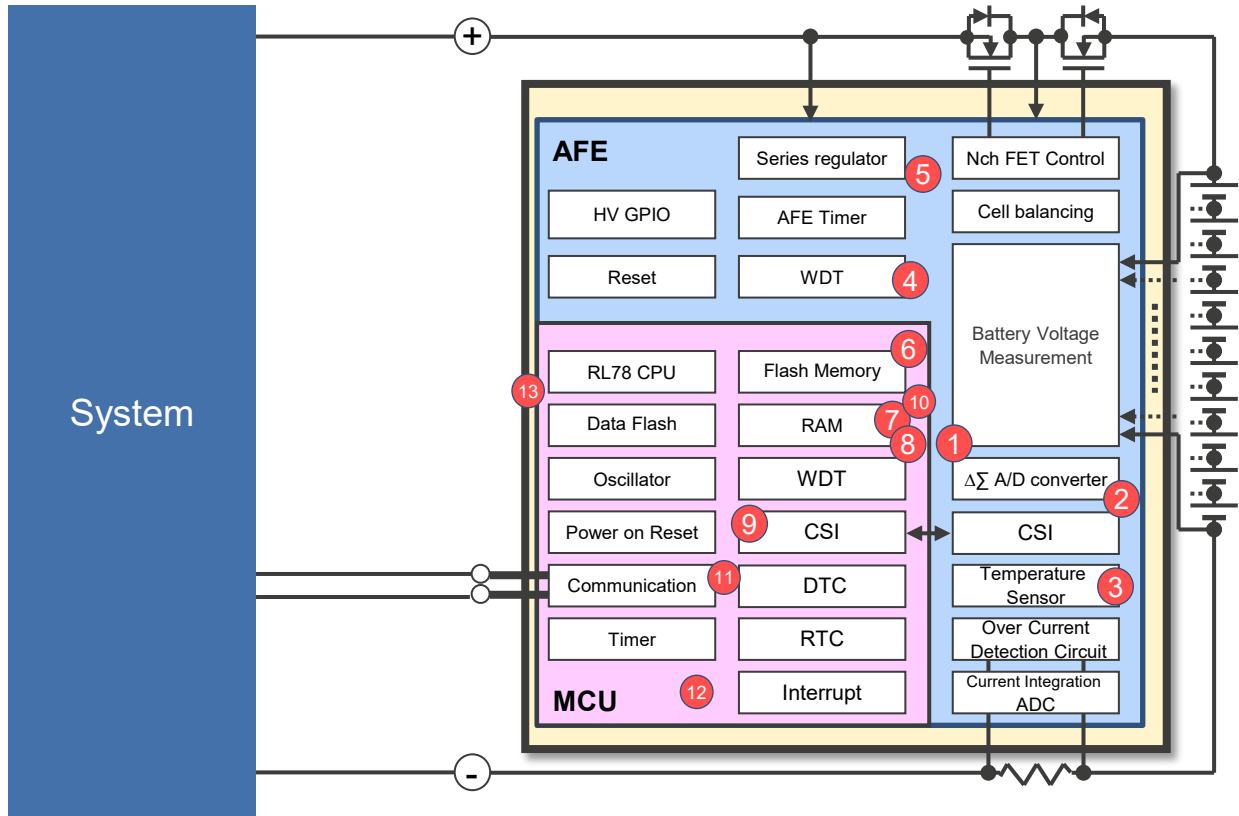

AFE part	
1	Voltage monitor (Over/Under)
2	Temperature monitor (Over/Under)
3	Junction temperature monitoring
4	MCU runaway detection circuit (WDT)
5	Internal LDO voltage drop detection circuit

MCU part	
6	Flash memory CRC operation function
7	RAM parity error detection function
8	RAM guard function
9	SFR guard function
10	Invalid memory access detection function
11	Frequency detection function
12	A/D test function
13	Digital output signa level detection function for I/O pins

Functional Safety system has to be designed by the customer (the manufacturer of the application) based on the entire system. Renesas supports our customers' functional safety system design via the FGIC's protection and self-diagnostic functions, as well as the sample code and manuals. For detail, please contact your Renesas sales representative.