

8V19N88x Hardware Design

This document provides general board-level design guidelines for the 8V19N88x JESD204B/C jitter attenuator family (see Table 1). The guidelines use the 8V19N882 device as an example and can be applied to other members of the family.

Table 1. 8V19N88x JESD204B/C Jitter Attenuator Family

Part Number	Built-in VCO Frequency	External VCO Frequency Range	Number of Input	Number of Output	Package
8V19N880	~3.93216GHz	700MHz to 6GHz	4	18	100-CABGA
8V19N882	~3.93216GHz	700MHz to 6GHz	2	16	76-VFQFN

This document will recommend the power rail handling, loop filter calculations, and input/output termination. A general schematic example is shown in Figure 2.

Contents

1. Power Rails	4
1.1 Bypass capacitors.....	4
1.2 Power Supply Isolation	4
2. Loop Filter	5
2.1 2 nd Order Loop Filter	5
2.2 3 rd Order Loop Filter	6
2.3 Loop Filter Calculation Examples	7
2.3.1. Loop Filter for VCXO PLL	7
2.3.2. Loop Filter for VCO PLL.....	10
3. Input Output Interface	11
3.1 Input Termination for Reference Clock Input.....	11
3.2 OSC_1 Input Termination (External VCO)	12
3.3 Output Terminations for QCLK and QREF Drivers	14
3.3.1. LVPECL Type Driver Terminations.....	14
3.3.2. LVDS Type Driver Terminations	18
4. Schematic Example	19
5. Revision History	19

Figure 1 shows a simplified block diagram of the 8V19N882: it represents the core functionality of all devices in the family. More detailed and individual block diagrams and device descriptions are available in the respective device datasheets.

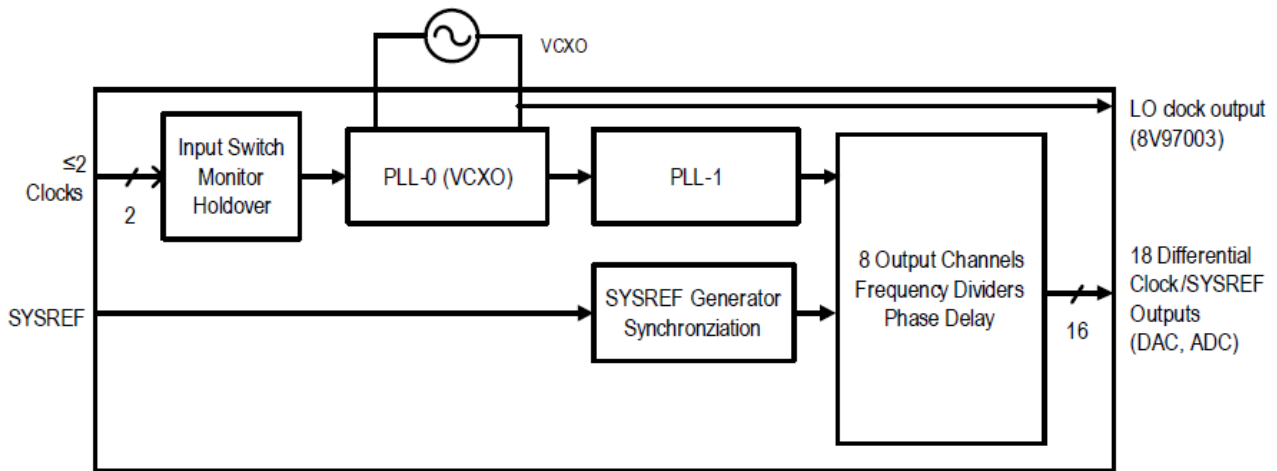

Figure 1. 8V19N882 Simplified Block Diagram

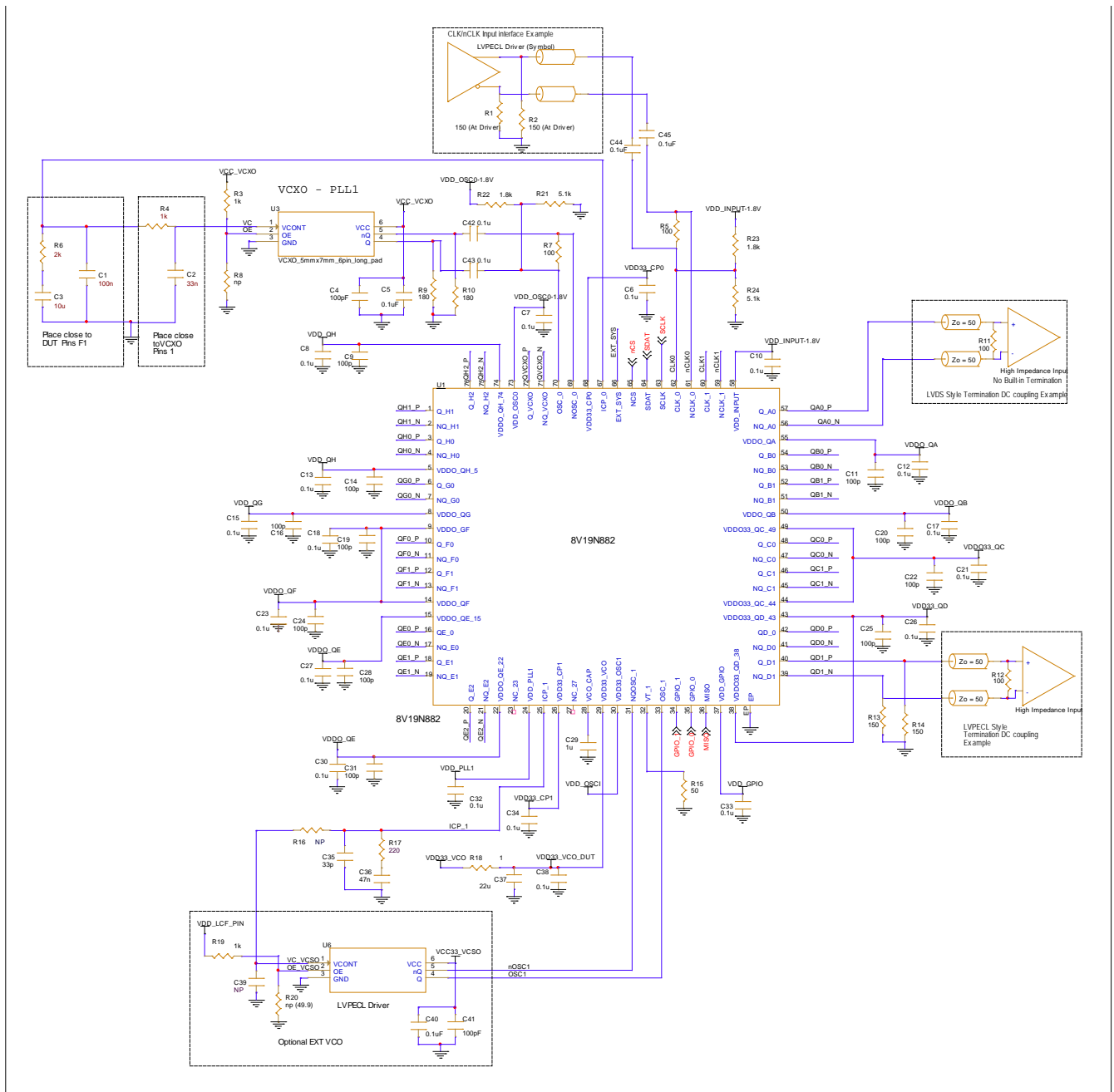

Figure 2. 8V19N882 Reference Schematic Example

Note: PCB layout files and schematics files will be provided upon request.

1. Power Rails

1.1 Bypass capacitors

Bypass capacitors are required to filter noise from switching power supplies and from other devices in the system to avoid signal interference. Figure 2 shows examples of bypass capacitors on the schematic. The type of bypass capacitor will depend on the noise level and noise frequencies on the application board. The device output driver switching can also cause power rail noise and interference with noise signals from other devices on the board, causing unwanted spurious tones in output signals. The bypass capacitors minimize these noise sources.

The bypass capacitor values are usually in the range from 0.01 μ F to 0.1 μ F. Other values can also be used. Typical capacitor sizes are 0603, 0402, or 0201 with a low ESR. The dielectric types are typically X5R or X7R. A smaller size allows the capacitor to be placed closer to the power pin of the device with a reduced trace length.

To minimize ESR between power pins and the bypass capacitors, it is recommended to place at least one bypass capacitor at each VDD power pin, with a placement as near as possible to the respective power pin of the device. A thick trace width between the bypass capacitor and the power pin helps to reduce ESR. It is recommended to combine multiple capacitors at different resonance frequencies to achieve a band pass filter characteristics at the critical noise frequencies.

1.2 Power Supply Isolation

The power rails should be as noise free as possible to support the low-phase noise performance of the device PLLs. The 8V19N88x devices also integrate LDOs for additional noise filtering. An external ultra-low noise LDO may not be required but is recommended for reducing power supply noise further. The power pins with the highest noise sensitivity is VDD_LCF. The power supply for the external VCXO must also be filtered as much as possible. An LDO should have a noise level of less than 6.5 μ V_{rms} from 10Hz to 100kHz. The Renesas RAA214020 is a suitable LDO and has been verified as a power supply circuit for the 8V19N88x and for the external VCXO.

It is recommended to isolate the analog power rail from other high-noise power rails, VDDO_x and VDD_INPUT. The isolation can be implemented through an RC low-pass filter. The larger RC component values can reduce the cutoff frequency further and clean up lower frequency noise. For the output supplies VDDO_x, to reduce output frequency interference, the power rails between the output banks that operate at different output frequencies can be isolated using separate LDOs or using 1 to 2 ohm resistors if they share the same power source. Additional smaller value capacitors (e.g., 100pF) in parallel with the existing 0.1 μ F near the power pins can provide additional higher frequency noise filtering.

2. Loop Filter

2.1 2nd Order Loop Filter

This section discusses design information for a 2nd order loop filter for PLL. Figure 3 shows a typical 2nd order loop filter. It also provides a step-by-step calculation to determine R_s , C_s , and C_p values. The required parameters for this part are also provided. A spreadsheet or software tool for calculating the loop filter values are also available.

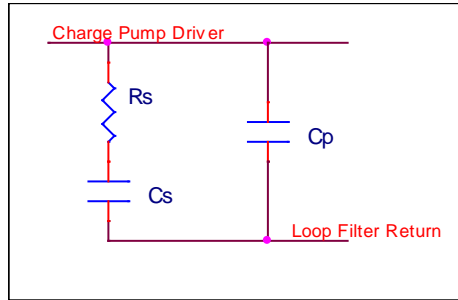

Figure 3. Typical 2nd Order Loop Filter

1. Determine desired loop bandwidth f_c . The f_c must satisfy the following condition:

$$\frac{F_{pd}}{f_c} \gg 20$$

Where, F_{pd} is phase detector input frequency.

2. Calculate R_s

$$R_s = \frac{2 * \pi * f_c * N}{I_{cp} * K_{vco}}$$

Where,

I_{cp} is charge pump current.

K_{vco} is VCO gain.

N is effective feedback divider.

$$N = \frac{F_{vco}}{F_{pd}}$$

F_{vco} is vco frequency.

F_{pd} is the phase detector input frequency.

3. Calculate C_s

$$C_s = \frac{\alpha}{2 * \pi * f_c * R_c}$$

Where,

α is ratio between loop bandwidth and the zero frequency at zero, $\alpha = f_c / f_z$, recommend α greater than 3.

f_z is frequency at zero.

4. Calculate Cp

$$Cp = \frac{Cs}{\alpha * \beta}$$

Where,

β is ratio between frequency at pole and loop bandwidth, $\beta = fp / fc$, recommend β greater than 3.

fp is frequency at pole.

5. Verify maximum Phase Margin, PM

$$PM = \arctan\left(\frac{b-1}{2 * \sqrt{b}}\right)$$

Where,

$$b = 1 + \frac{Cs}{Cp}$$

PM should be greater than 50 degrees.

2.2 3rd Order Loop Filter

This section provides design information for a 3rd order loop filter. A typical 3rd order loop filter is shown in Figure 4.

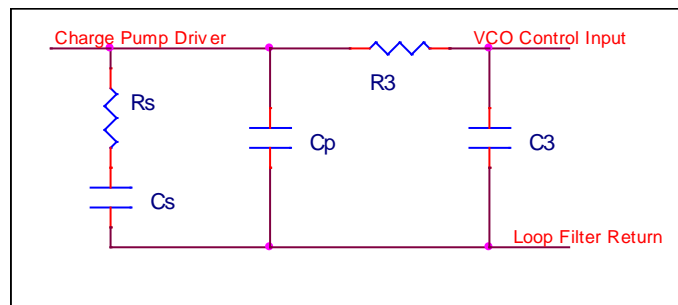

Figure 4. Typical 3rd Order Loop Filter

The R_s , C_s , and C_p can be the actual value used in the 2nd order loop filter. The following equation helps determine the 3rd order loop filter R_3 and C_3 .

Pick an R_3 value. Suggest $R_3 \sim 1.5xR_s$

$$C3 = \frac{Rs * Cp}{R3 * \gamma}$$

Where,

γ is ratio between the 1st pole frequency and the 2nd pole frequency. Suggest γ greater than 3.

The Timing Commander software tool is provided to calculate the loop filter component values. To use the spreadsheet, you can enter the follow parameters:

fc , Fpd , $fvco$, α , and β .

The software tool will provide the component values, R_s , C_s , and C_p as result. The spreadsheet will also calculate maximum phase margin for verification.

The 3rd order loop filter R_3 and C_3 is also calculated using the actual 2nd order loop filter components values.

2.3 Loop Filter Calculation Examples

2.3.1. Loop Filter for VCXO PLL

2.3.1.1. Second Order Loop Filter for the VCXO PLL

This section provides a calculation example for the VCXO PLL loop filter value. The 8V19N88x VCXO phase lock loop block diagram is displayed in Figure 5. A 2nd order loop filter for VCXO is displayed in Figure 6. In this example, the reference CLK input frequency is 30.72MHz and a VCXO with output frequency of 122.88MHz is used.

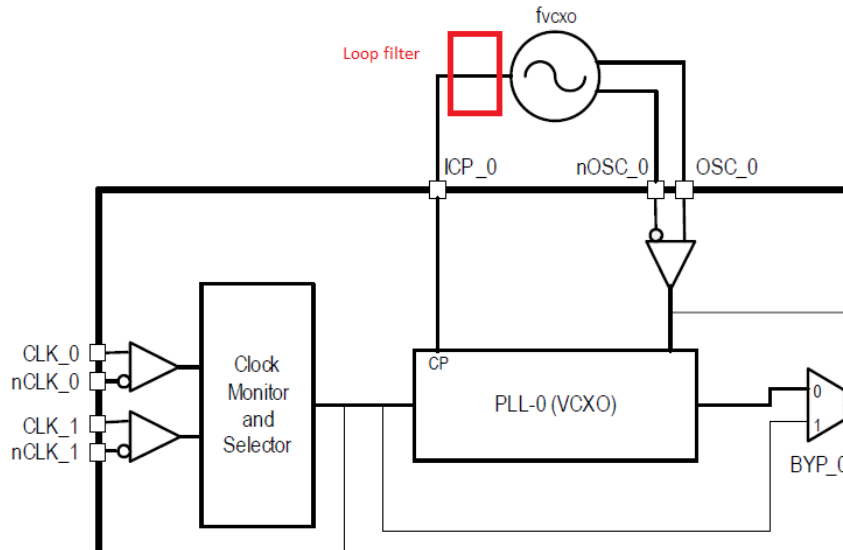

Figure 5. 8V19N88X VCXO Phase Lock Loop Block Diagram

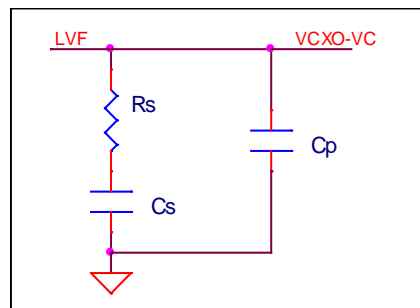

Figure 6. Typical 2nd Order Loop Filter

To calculate loop filter component values for loop bandwidth $F_c = 40\text{Hz}$ with the reference CLK input frequency equals to 30.72MHz, set input pre-divider $P_v = 16$. The phase detector input frequency $F_{pd} = 0.96\text{MHz}$. This satisfies the condition of:

$$F_{pd}/F_c \gg 20.$$

The VCXO frequency $F_{vcxo} = 122.88\text{MHz}$, the effective feedback divider

$$N = M_v = F_{vcxo} / F_{pd} = 128$$

R_s can be calculated from the equation,

$$R_s = \frac{2 * \pi * f_c * N}{I_{cp} * K_{vco}}$$

$$R_s = 2.2\text{k Ohm}$$

Kvco VCO gain can be found or derived from the VCXO datasheet. The VCO gain can also be measured from lab experiment. In this example, we use $K_{vco} = 10\text{kHz/V}$.

The 8V19N88x charge pump current can be set up to 3mA from 100uA or 200uA and I_ICP0_OFFSET registers. In this example, assume the charge pump current is programmed to $I_{cp0} = 1.5\text{mA}$.

Cs can be calculated from the following equation,

$$C_s = \frac{\alpha}{2 * \pi * f_c * R_c}$$

For $\alpha = 3$, Cs is calculated to be 5.6μF. Cs greater than this value can be used to assure that the α is greater than 3. For example, the actual chosen value can be 10μF from a standard capacitor value.

Cp can be calculated from the equation,

$$C_p = \frac{C_s}{\alpha * \beta}$$

For $\beta = 4$, Cp is calculated to be 463nF. Less than this value can be used for Cp to guarantee that the β is greater than 4 (e.g., actual chosen value Cp can be 330nF).

2.3.1.2. Third Order Loop Filter for the VCXO PLL

This section helps design a 3rd order loop filter for 8V19N88x VCXO PLL. A general 3rd order loop filter is displayed in Figure 7.

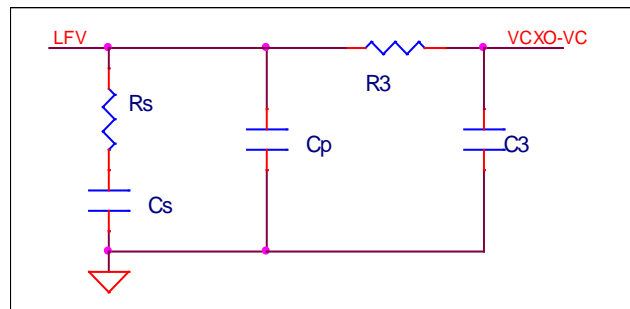

Figure 7. Typical 3rd Order Loop Filter

The Rs, Cs, and Cp are actual chosen standard values from the 2nd order loop filter. In this example, the actual chosen values are $R_s = 2.2\text{k Ohm}$, $C_s = 10\mu\text{F}$, and $C_p = 330\text{nF}$. The following equation will help determine the 3rd order loop filter R3 and C3.

Pick an R3 value. Suggest $R_3 \sim 0.5xR_s$ to $\sim 2.5xR_s$ or greater (e.g., $R_3 = 2.2\text{k Ohm}$ is used in this example). C3 can be calculated using the following equation,

$$C_3 = \frac{R_s * C_p}{R_3 * \gamma}$$

Pick $\gamma = 4$ in this example

C3 is calculated to be 82.5nF. A smaller standard capacitor value can be used.

Table 2 shows some VCXO PLL Loop Filter examples for different VCXO frequencies. Other values can also be used to meet other specific conditions and requirements.

Table 2. VCXO PLL Loop Filter Examples

VCXO Frequency^[1]	122.88MHz	30.72MHz
VCXO Made/Model examples	Epson, VG4513CA/CB Epson VG3225EFN Crystek CVPD922 Crystek CHPD950 Crystek CVPD-037 Rakon RVX7050M TXC Vectron	Epson, TXC, Rakon
Typical VCXO gain, Kvco	10k Hz/V	2.5k Hz/V
Loop Band width, Fc	~40Hz	~40Hz
PDF, Phase Detector input Frequency	960kHz	960 kHz
Feedback Divider (N or Mv)	128	32
Charge pump current setting (Can be slightly Adjusted to change the loop band width)	1500uA	1500uA
Rs	2.2k Ohm	2.2k Ohm
Cs	6.8μF	6.8μF
Cp	330nF	330nF
R3	2.2k Ohm	2.2k Ohm
C3	33nF	33nF

1. Other VCXO frequencies can also be used with proper loop filter and parameter settings. The following list are examples of VCXO order information:

- * 122.88MHz - Epson VG3225EFN 122.88M-CJHHBA
- * 245.76MHz - Epson VG3225ENN 245.76M-CJHHMA
- * 491.52MHz - Epson VG3225ENN 491.52M-CJGHSA

2.3.2. Loop Filter for VCO PLL

The 8V19N88x VCO phase lock loop diagram is displayed in Figure 8. The internal VCO frequency F_{vco} is 3.93216GHz. In this example, the 3.93216GHz VCO is used. A 2nd order loop filter for the VCO is displayed in Figure 9.

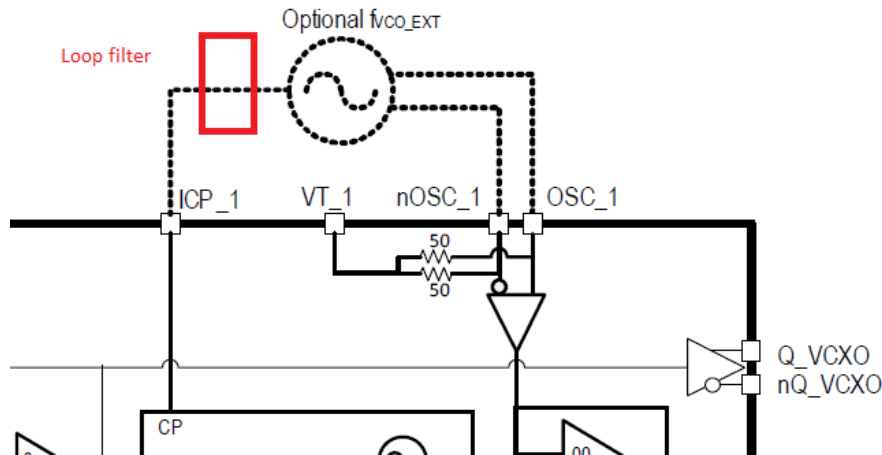

Figure 8. VCO PLL Block Diagram

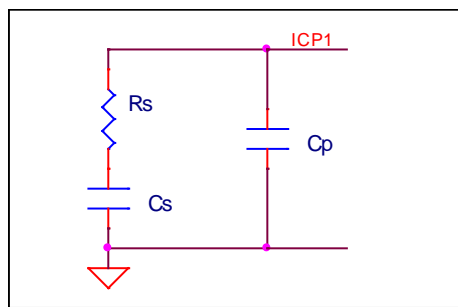

Figure 9. 2nd Order Loop Filter for the VCO

The board-level VCO 2nd order loop filter works in conjunction with the internal circuitries. A traditional loop filter calculation method cannot be used. The external 2 pole loop filter value examples are provided in Table 3.

Table 3. VCO PLL 2nd Order Loop Filter Example

VCXO used in the VCXO PLL	122.88MHz	30.72MHz
PDF, Phase detector input frequency with doubler on	245.76MHz	61.44MHz
Feedback divider	16	64
Suggest Charge pump current setting	~ 1.5 ma (typical) Suggest range setting 400ua to 3 ma	~1.5ma (typical) Suggest range setting 400ua to 3 ma
Rs	220 Ohm Suggest range (100 – 1k Ohm)	560 Ohm Suggest range (100 to 1k Ohm)
Cs	47nF	47nF
Cp	~ 33pF	~ 33pF

3. Input Output Interface

3.1 Input Termination for Reference Clock Input

The 8V19N882 reference clock input CLK/nCLK is a high-impedance differential receiver. The inverting input nCLK has weak bias to 1.2V. The input can accept a signal from a standard LVDS driver directly without AC coupling. The board-level termination at the CLK/nCLK input is determined by the driver type. Figure 10 provides an example of an input interface without AC coupling, and Figure 11 and Figure 12 provide examples of input driven by a differential driver with AC coupling. This section provides only few examples. Other termination topologies can also be used.

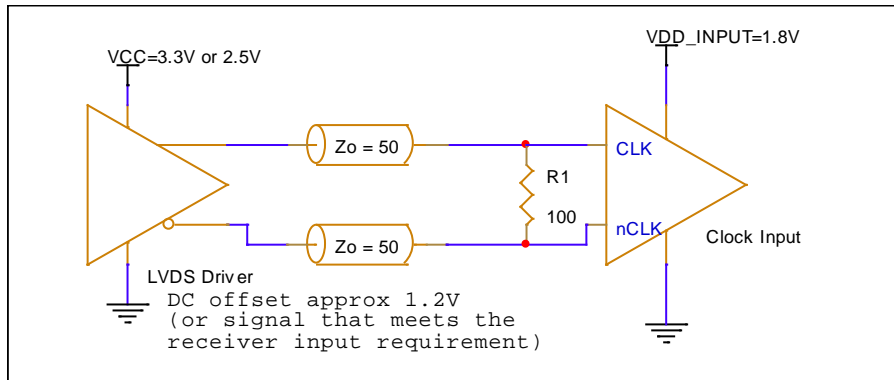

Figure 10. Input Termination Example – 8V19N882 Reference Clock Input CLK/nCLK Driven by an LVDS Driver

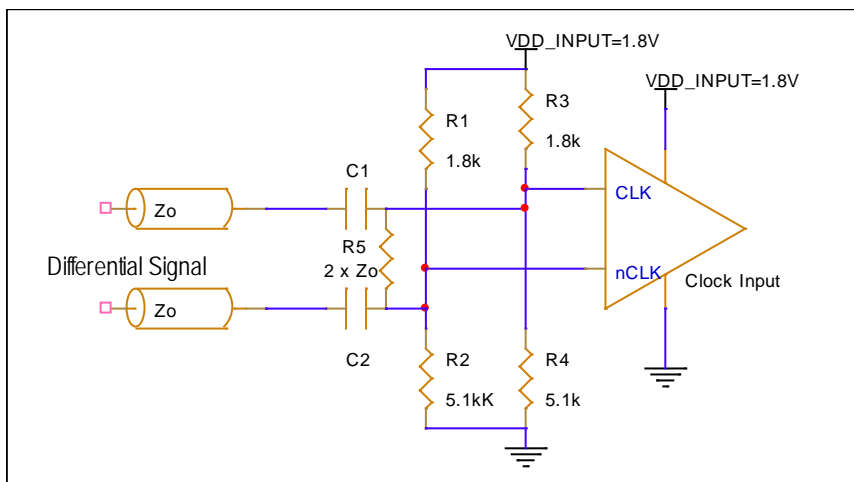

Figure 11. 8V19N882 Reference Clock Input CLK/nCLK AC Coupling Termination Example 1

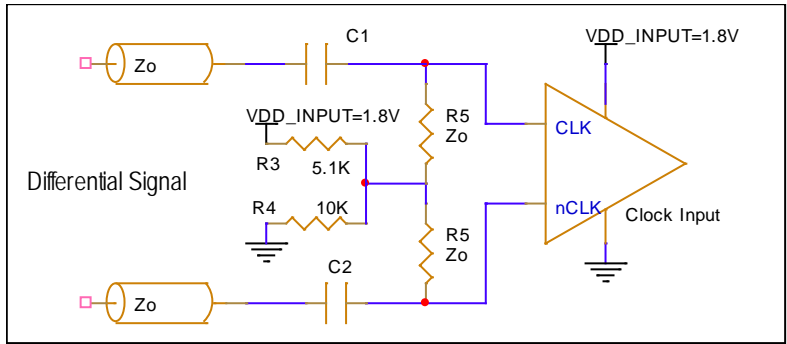

Figure 12. 8V19N882 Reference Clock Input CLK/nCLK AC Coupling Termination Example 2

3.2 OSC_1 Input Termination (External VCO)

The differential OSC_1/nOSC_1 input is used in applications with an external VCO as oscillator for PLL-1. For signal termination of the external VCO, the OSC_1/nOSC_1 input has two built-in 50Ohm termination resistors with its junction connected to the VT_1 pin. The external VCO can have a differential LVPECL, LVDS, or single-ended sinusoidal waveform output driver. See below for recommended interfaces.

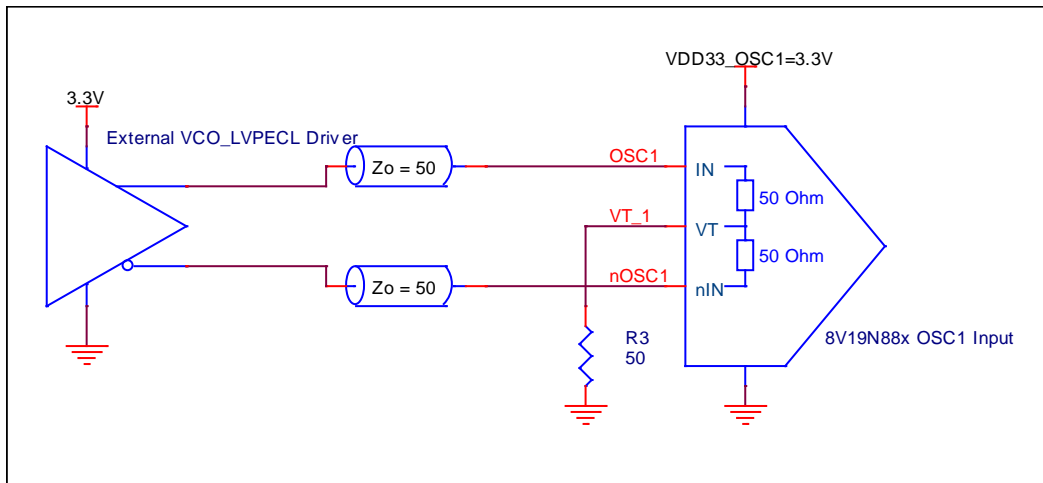

Figure 13. External VCO 3.3V LVPECL Driver to OSC_1/nOSC_1 Input Interface

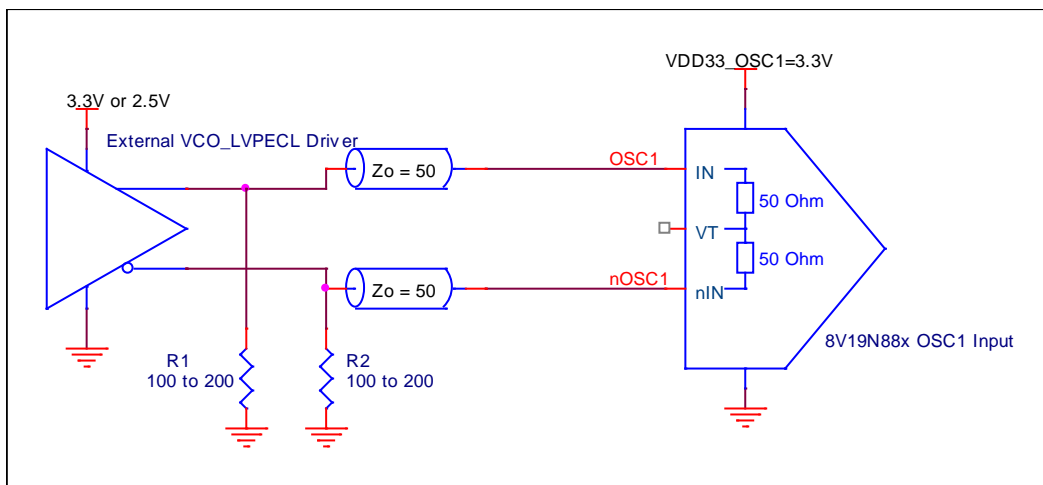

Figure 14. External VCO 3.3V LVPECL Driver to OSC_1/nOSC_1 Input, Alternative Interface

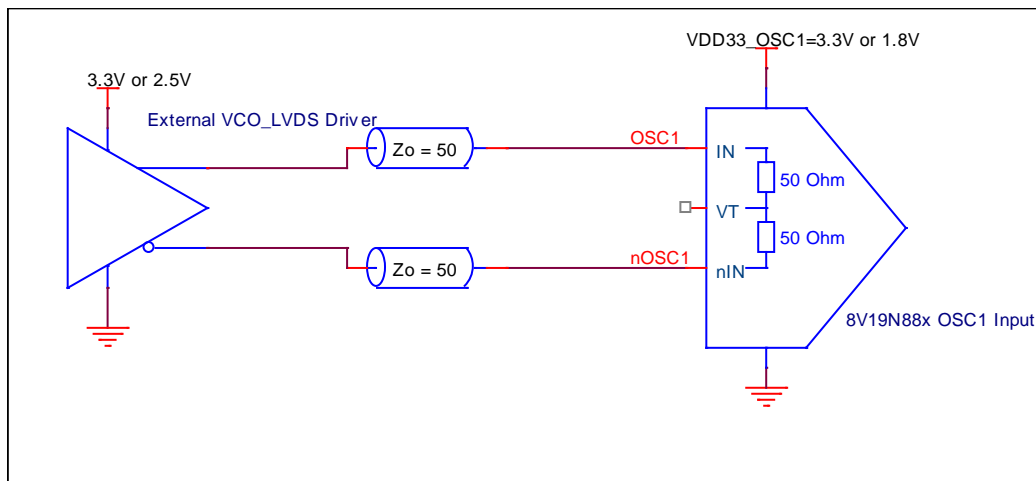

Figure 15. External VCO LVDS Driver to OSC_1/nOSC_1 Input Interface

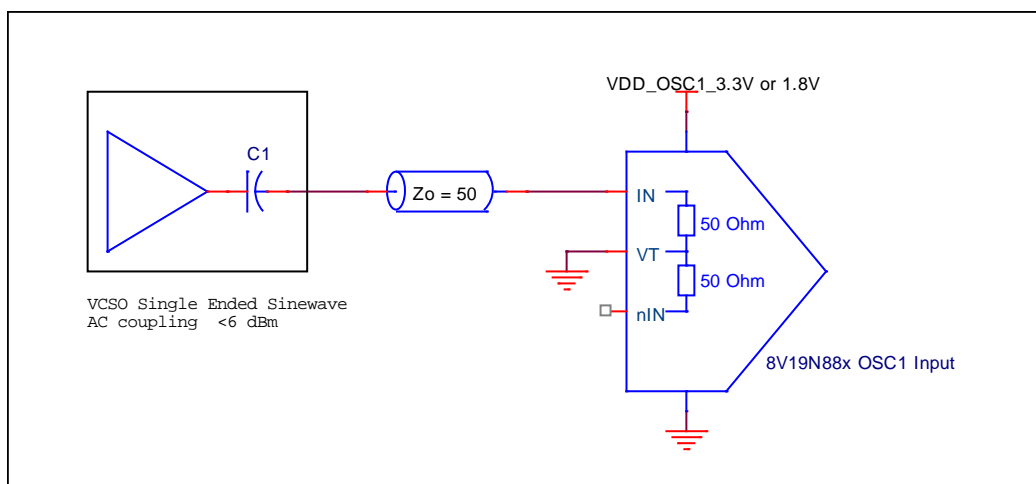

Figure 16. External VCO Single-ended Sinusoidal-Driver to OSC_1/nOSC_1 Input Interface

3.3 Output Terminations for QCLK and QREF Drivers

The output stage of the 8V19N882 QCLK drivers can be configured to LVPECL Style driver or LVDS Style driver.

3.3.1. LVPECL Type Driver Terminations

When the output is configured to LVPECL, the driver is an open emitter type requiring a DC current path to the termination voltage V_T through the pull-down resistor. A standard LVPECL driver termination is shown in Figure 17; Figure 18 to Figure 20 show alternative terminations. The LVPECL output driver is configurable and the applicable termination voltage V_T depends on the output amplitude setting and output supply voltage V_{DDO_v} . Refer to the V_T and termination resistor value tables below each diagram.

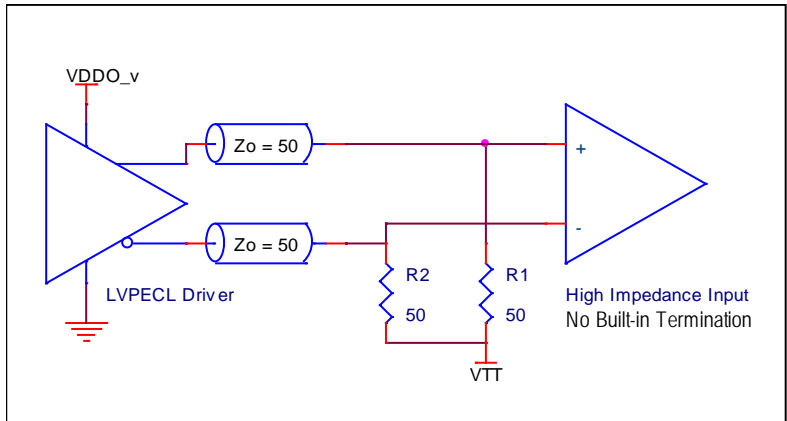

Figure 17. LVPECL Style Termination

Table 4. V_T Values for Output Termination in Figure 18

Output Supply Voltage	Output Amplitude	V_T
$V_{DDO_v} = 1.8V$	300mV	$V_{DDO_v} - 1.55V$
	400mV	$V_{DDO_v} - 1.65V$
	550mV	GND
	700mV	GND
$V_{DDO_v} = 2.5V$	300mV	$V_{DDO_v} - 1.55V$
	400mV	$V_{DDO_v} - 1.65V$
	550mV	$V_{DDO_v} - 1.8V$
	700mV	$V_{DDO_v} - 1.95V$
$V_{DDO_v} = 3.3V$	300mV	$V_{DDO_v} - 1.55V$
	400mV	$V_{DDO_v} - 1.65V$
	550mV	$V_{DDO_v} - 1.8V$
	700mV	$V_{DDO_v} - 1.95V$

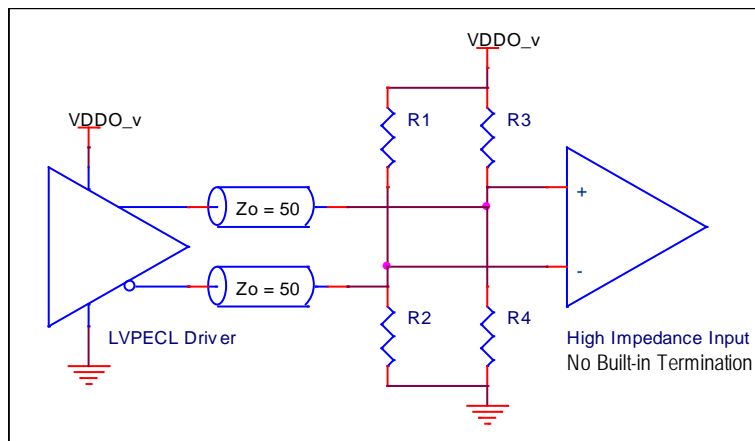

Figure 18. Alternative LVPECL Style Termination

Table 5. Resistor Values for Output Termination in Figure 18

Output Supply Voltage	Output Amplitude	R1, R3	R2, R4
$V_{DDO_v} = 1.8V$	300mV	360Ω	58.1Ω
	400mV	600Ω	54.5Ω
	550mV	No-pop	50Ω
	700mV	No-pop	50Ω
$V_{DDO_v} = 2.5V$	300mV	131.6Ω	80.6Ω
	400mV	147.1Ω	75.8Ω
	550mV	178.6Ω	69.4Ω
	700mV	227.3Ω	64.1Ω
$V_{DDO_v} = 3.3V$	300mV	94.2Ω	106.5Ω
	400mV	100Ω	100Ω
	550mV	110Ω	91.7Ω
	700mV	122.2Ω	84.6Ω

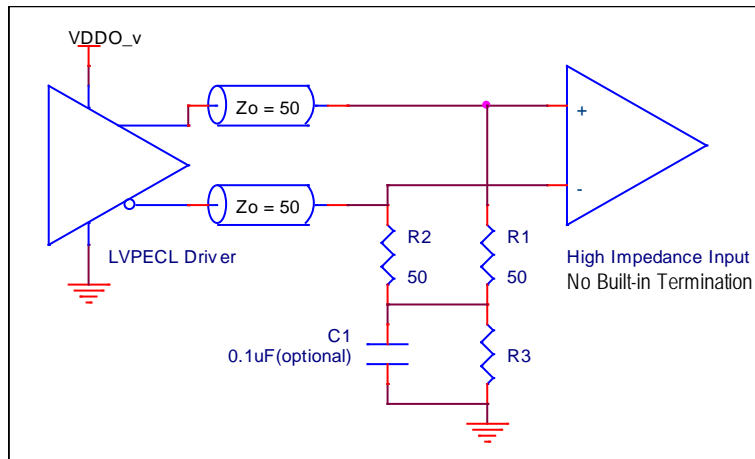

Figure 19. Alternative LVPECL Style Termination

Table 6. Resistor Values for Output Termination in Figure 19

Output Supply Voltage	Amplitude	R3
$V_{DDO_V} = 1.8V$	300mV	14Ω
	400mV	7.6Ω
	550mV	0Ω
	700mV	0Ω
$V_{DDO_V} = 2.5V$	300mV	53.1Ω
	400mV	43.8Ω
	550mV	27.9Ω
	700mV	22.4Ω
$V_{DDO_V} = 3.3V$	300mV	80.6Ω
	400mV	73.3Ω
	550mV	61.2Ω
	700mV	50Ω

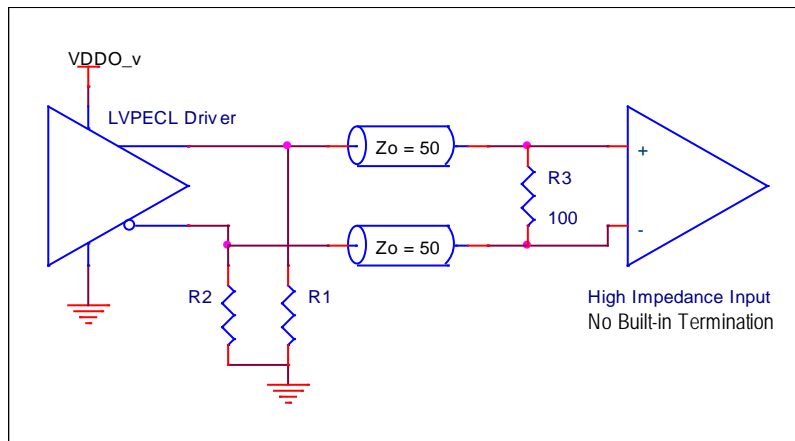

Figure 20. Alternative LVPECL Style Termination

Table 7. Resistor Values for Output Termination in Figure 20

Output Supply Voltage	Amplitude	R1, R2 (Ohm)
$V_{DDO_V} = 1.8V$	300mV	77.9Ω
	400mV	65.3Ω
	550mV	50Ω
	700mV	50Ω
$V_{DDO_V} = 2.5V$	300mV	156Ω
	400mV	138Ω
	550mV	116Ω
	700mV	94.9Ω
$V_{DDO_V} = 3.3V$	300mV	211Ω
	400mV	196Ω
	550mV	172Ω
	700mV	150Ω

3.3.2. LVDS Type Driver Terminations

Unlike the LVPECL style driver, the LVDS style driver does not require a board-level pull-down resistor. Figure 21 and Figure 22 show typical termination examples with DC coupling for the LVDS style driver. A termination example with AC coupling is shown in Figure 23. The following figures are for LVDS receivers with a high-input impedance (no built-in 100Ω termination). For receivers with built-in 100Ω termination, see the note below Figure 23.

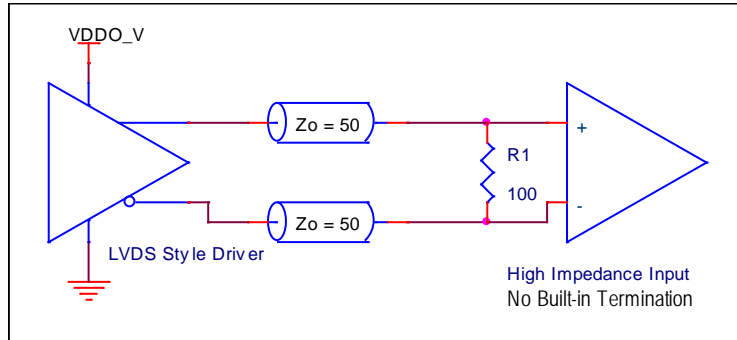

Figure 21. LVDS Style Driver Termination (DC Coupled)

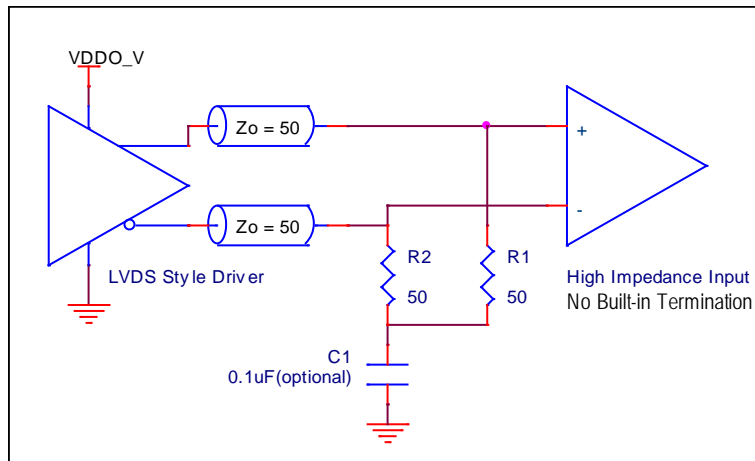

Figure 22. LVDS Style Alternative Driver Termination (DC Coupled)

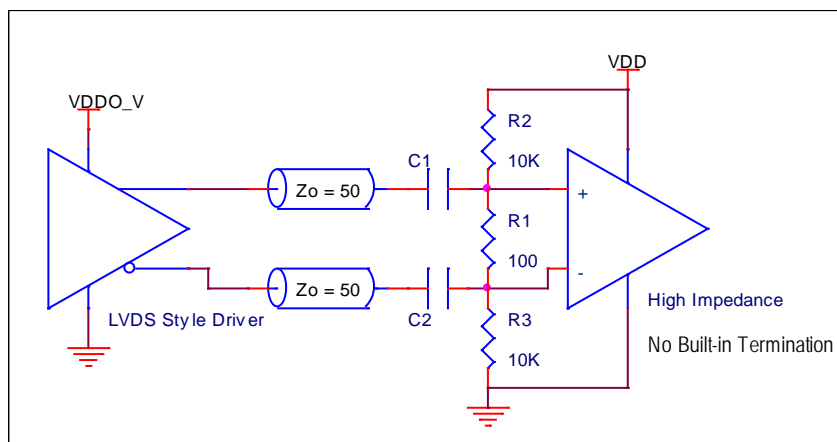

Figure 23. LVDS Style Alternative Driver Termination (AC Coupled)

For receivers with built-in 100Ω termination that provide their own DC offset (self-bias): Apply the AC-coupled termination displayed in Figure 23 and do not populate the resistors R1, R2, and R3.

4. Schematic Example

Reference demo board schematic and the board layout are available upon request

- 8V19N882 EVB schematic
- 8V19N882 EVB board layout

5. Revision History

Revision	Date	Description
1.02	Sep 21, 2022	<ul style="list-style-type: none">▪ Updated Figures 2 and 10-12▪ Deleted the previous figure numbered 10.
1.01	Jun 1, 2021	Added VCXO order information to Table 2 (see footnote 1).
1.00	Mar 31, 2021	Initial release.

IMPORTANT NOTICE AND DISCLAIMER

RENESAS ELECTRONICS CORPORATION AND ITS SUBSIDIARIES (“RENESAS”) PROVIDES TECHNICAL SPECIFICATIONS AND RELIABILITY DATA (INCLUDING DATASHEETS), DESIGN RESOURCES (INCLUDING REFERENCE DESIGNS), APPLICATION OR OTHER DESIGN ADVICE, WEB TOOLS, SAFETY INFORMATION, AND OTHER RESOURCES “AS IS” AND WITH ALL FAULTS, AND DISCLAIMS ALL WARRANTIES, EXPRESS OR IMPLIED, INCLUDING, WITHOUT LIMITATION, ANY IMPLIED WARRANTIES OF MERCHANTABILITY, FITNESS FOR A PARTICULAR PURPOSE, OR NON-INFRINGEMENT OF THIRD-PARTY INTELLECTUAL PROPERTY RIGHTS.

These resources are intended for developers who are designing with Renesas products. You are solely responsible for (1) selecting the appropriate products for your application, (2) designing, validating, and testing your application, and (3) ensuring your application meets applicable standards, and any other safety, security, or other requirements. These resources are subject to change without notice. Renesas grants you permission to use these resources only to develop an application that uses Renesas products. Other reproduction or use of these resources is strictly prohibited. No license is granted to any other Renesas intellectual property or to any third-party intellectual property. Renesas disclaims responsibility for, and you will fully indemnify Renesas and its representatives against, any claims, damages, costs, losses, or liabilities arising from your use of these resources. Renesas' products are provided only subject to Renesas' Terms and Conditions of Sale or other applicable terms agreed to in writing. No use of any Renesas resources expands or otherwise alters any applicable warranties or warranty disclaimers for these products.

(Disclaimer Rev.1.01 Jan 2024)

Corporate Headquarters

TOYOSU FORESIA, 3-2-24 Toyosu,
Koto-ku, Tokyo 135-0061, Japan
www.renesas.com

Trademarks

Renesas and the Renesas logo are trademarks of Renesas Electronics Corporation. All trademarks and registered trademarks are the property of their respective owners.

Contact Information

For further information on a product, technology, the most up-to-date version of a document, or your nearest sales office, please visit www.renesas.com/contact-us/.