

# CN190-1-5GPWR-REFZ

## 5G Second Stage Power Reference Design

 Rev.1.0  
 Jan. 07, 2022

### Description

5G communication base station needs high-performance low-cost non-isolated PA power supply system. This solution provides an AAU PA power solution to enable -48V to 48V non-isolated solution. It supports up to 1500W output.

### Specifications

The design specifications of the CN190-1-5GPWR-REFZ 5G Second Stage Power Solution are shown in Table 1.

**TABLE 1. SPECIFICATIONS**

Parameters	Values
Input Voltage (VIN)	36V to 60V
Output Voltage (VOUT)	42V to 52V
Rated Output Power	1500W

### Key Features

- Wide input and output voltage range dual phase interleave parallel able boost controller which is suitable for high power, high accuracy, and high efficiency power supply
- Low cost MCU collects power system information by IIC bus
- PC terminal via USB control output

### References

ISL81805 Datasheet

RAA223011 Datasheet

RAA214220 Datasheet

RL78/G1F Datasheet



Figure1 Top View

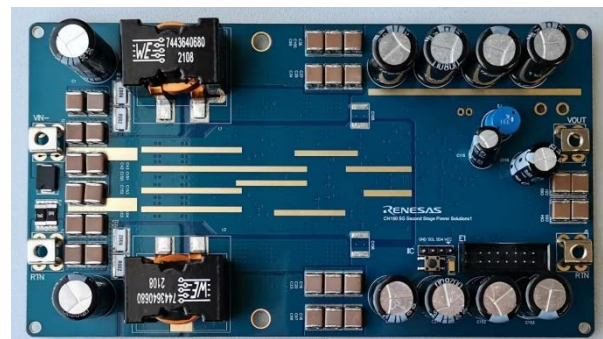

Figure2 Bottom View

## CN190-1-5GPWR-REFZ 5G Second Stage Power Solution

### Functional Description

The CN190-1-5GPWR-REFZ 5G Second Stage Power Solution is the application of High-Performance power tree for core & peripheral.

The board allows quick evaluation of the 80V Dual Synchronous Boost Controller ISL81805 and the output voltage can be adjusted by using IIC interface bus.

Use 700V AC/DC Buck Regulator with Ultra-Low Standby Power RAA223011 to provide power the MOSFET driver IC.

Use 20V, Low Quiescent Current, 150mA Linear Regulator RAA214220 to provide power the MCU RL78/G1F, the RL78/G1F is used to receive the control signal from the PC, adjust and report the output voltage of ISL81805.

After connecting the PC and CN190-1-5GPWR-REFZ board using the USB-to-IIC-board, the CN190-1-5GPWR-REFZ GUI can be used to adjust the voltage of the CN190-1-5GPWR-REFZ board. And the output voltage and the input voltage can be monitored in real time on the GUI.

### Quick Test Setup

- **Default output 48V**

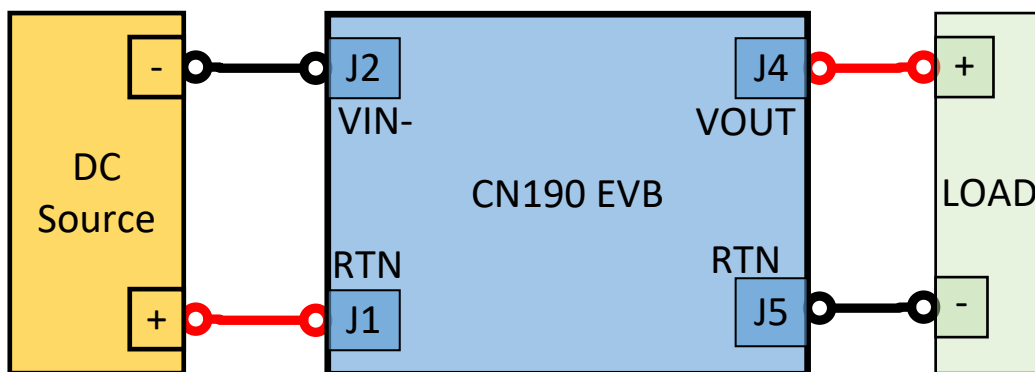

Figure 3 The Connection of the Default Output

- 1, Connect the power supply to the input terminals RTN(J1) and VIN-(J2). Connect the load to the output VOUT (J4) and RTN (J5). Make sure the setup is correct prior to applying any power or load to the board. Refer to Figure 3.
- 2, Adjust the power supply to 36V to 60V and turn it on.
- 3, Verify the output voltage is 48V (VOUT).

- Adjust the output by the GUI

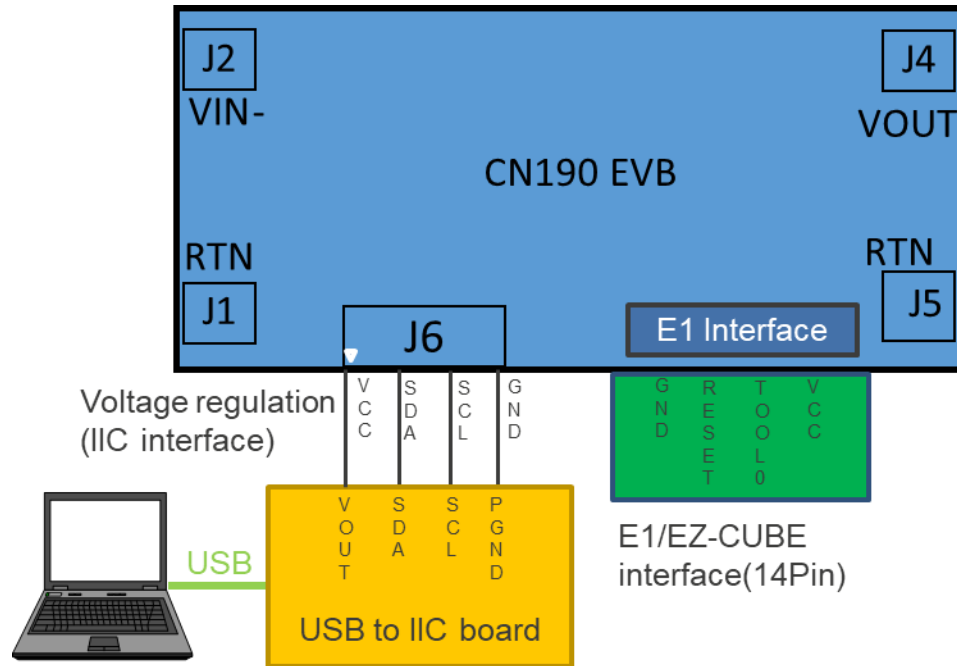

Figure 4 The Connection of Adjust the Output by GUI

1. Connect the power supply to the input terminals RTN(J1) and VIN-(J2). Connect the load to the output VOUT (J3) and RTN (J4). Connect the IIC interface on the CN190-1-5GPWR-REFZ board to the USB-to-IIC-board in order, make sure the setup is correct prior to applying any power or load to the board. Refer to Figure 4
2. Use a USB cable (type A (Male)-USB micro (Male)) to connect the PC to the USB-to-IIC-board. Refer to Figure 4.
3. Adjust the power supply to 36V to 60V and turn it on.
4. Open the GUI on the PC, select the COM port of the USB-to-IIC-board, click the “Connect” button, you can view the VIN and VOUT voltages in the “Monitor” box, and adjust the VOUT voltage through the “VOUT Set”.

# CN190-1-5GPWR-REFZ 5G Second Stage Power Solution

## GUI Screenshot

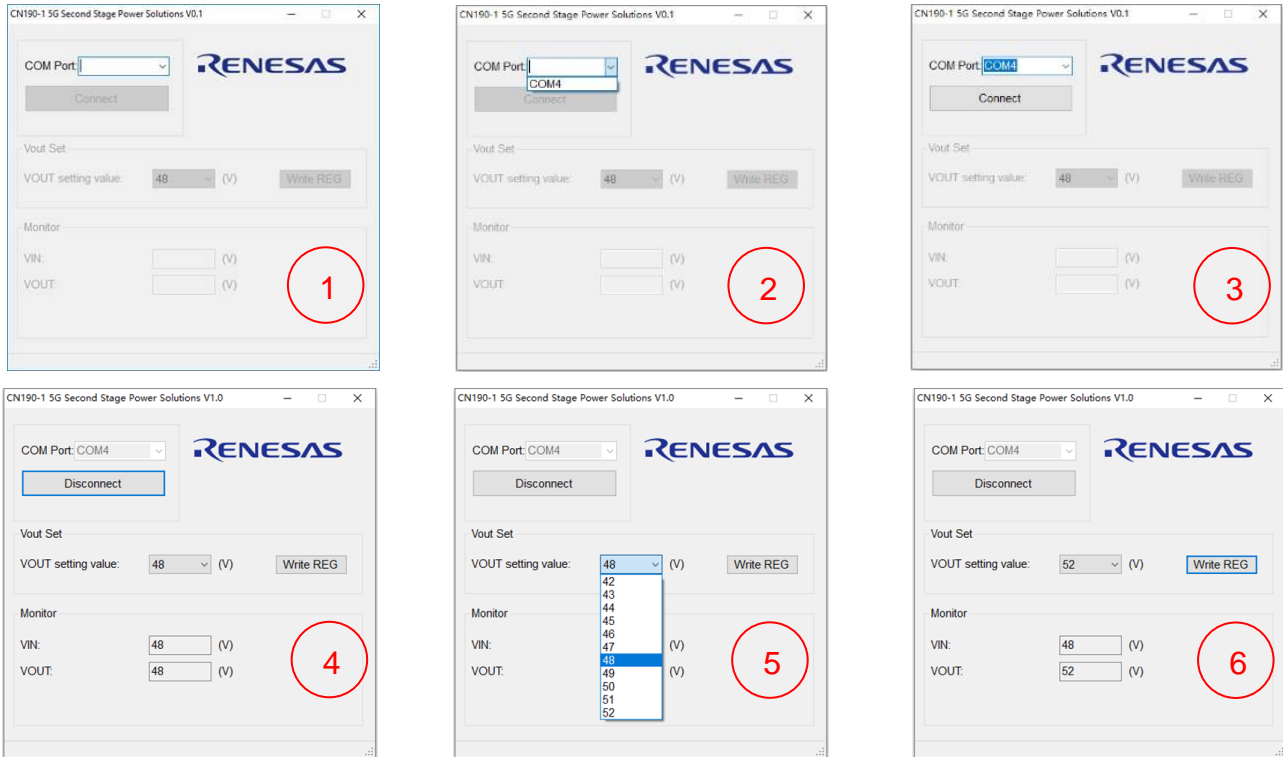

Figure 5 GUI Screenshot

1. Open the "CN190-1\_GUI\_VXXX.exe", Figure 5-1 after opening.
2. Select Com Port, click the "Connect" button to connect the CN190-1-5GPWR-REFZ board, Figure 5-2, 5-3, 5-4.
3. Select the setting voltage value, Click the "Write REG" button to send the setting value to MCU, Figure 5-5.
4. Display the voltage values in real time, Figure 5-6.

CN190-1-5GPWR-REFZ 5G Second Stage Power Solution

CN190-1-5GPWR-REFZ 5G Second Stage Power Solution Circuit Schematic

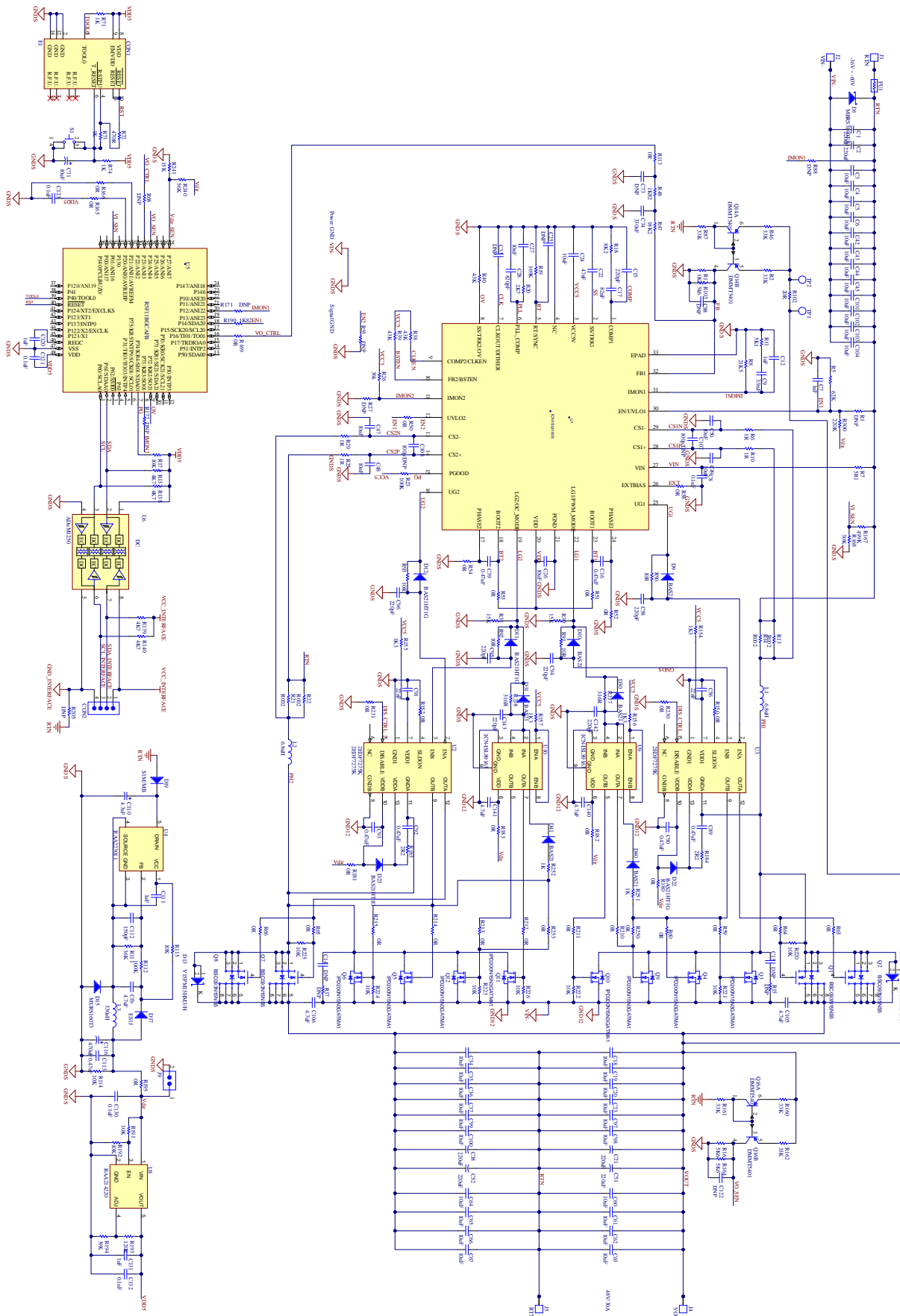

Figure 6 Circuit Schematic

# CN190-1-5GPWR-REFZ 5G Second Stage Power Solution

## Bill of Materials

TABLE 2. BOM List (1/3)

Designator	Description	Manufacturer	Mfg Part Number	QTY
C1, C2, C21, C38, C51, C52	CAP ALUM 220UF 20% 100V RADIAL	UCC	EKZN101ELL221MK25S	6
C3, C4, C5, C6, C18, C19, C20, C23, C34, C35, C36, C37, C42, C43, C44, C45, C60, C61, C62, C63, C64, C65, C66, C67, C97, C98, C99, C100, C101, C102, C103, C104	Ceramic Chip Capacitor 2220 10uF 100V	Murata	KCM55TR72A106MH01K	32
C7, C12	Ceramic Chip Capacitor 0603 1nF 50V	MURATA	GRM1885C1H102JA01D	2
C8, C121, C123, C130, C132	Ceramic Chip Capacitor 0603 0.1uF 50V	MURATA	GCM188L81H104KA57D	5
C9	Ceramic Chip Capacitor 0805 3.9nF 100V	MURATA	GRM2165C2A392JA01D	1
C13, C14, C25, C33, C73, C88, C122, C140, C141, C142, C143	Not assembled			DNP
C15, C58, C94, C95, C96	Ceramic Chip Capacitor 0603 220pF 100V	Murata	GCM1885C2A221JA16D	5
C16, C39, C113	Ceramic Chip Capacitor 0603 0.47uF 25V	MURATA	GRM188R71E474KA12D	3
C17	Ceramic Chip Capacitor 0603 82nF 50V	MURATA	GCM188L81H823KA57J	1
C22	Ceramic Chip Capacitor 0603 47nF 50V	MURATA	GCJ188R71H473KA12D	1
C24, C26	Ceramic Chip Capacitor 0805 10uF 16V	MURATA	GRM21BR61C106KE15L	2
C27, C47, C48, C49, C50, C107, C108	Ceramic Chip Capacitor 0603 10nF 100V	MURATA	GCM188R72A103KA37J	7
C28	Ceramic Chip Capacitor 0603 820pF 50V	MURATA	GRM1555C1H821JA01D	1
C56, C91	Ceramic Chip Capacitor 0603 22nF 50V	MURATA	GCE188R71H223KA01D	2
C71	Tantalum Capacitor 1206 10uF 16V	AVX	TAJA106K016SNJ	1
C74	Ceramic Chip Capacitor 0805 330nF 100V	MURATA	GRM21AR72A334KAC5L	1
C89, C90, C92, C93	Ceramic Chip Capacitor 0805 0.47uF 50V	MURATA	GCM21BR71H474KA55K	4
C105, C106	Ceramic Chip Capacitor 2220 4.7uF 250V	-	-	2
C110	Aluminum Electrolytic Capacitors - Radial Leaded 4.7uF 450V	Panasonic	ECA-2WHG4R7	1
C111, C120, C131	Ceramic Chip Capacitor 0603 1uF 50V	MURATA	GRT188R61H105KE13D	3
C112	Ceramic Chip Capacitor 0603 150pF 100V	Murata	GCM1885G2A151GA16D	1
C116	Aluminum Electrolytic Capacitors - Radial Leaded 25VDC 470uF 8x15mm LS3.5mm	Panasonic	EEU-FR1E471Y	1
Cfb	Ceramic Chip Capacitor 0805 4.7uF 50V	MURATA	GRM21BR61H475KE51L	1
CON1	Header 7X2, 14-Pin, 2.54mm	3M	2514-6002	1
CON2	Header 0.1" pitch 4pos 1x4	FCI	77311-818-04LF	1
D1	Schottky Diodes & Rectifiers 3A 100V	onsemi	MBRS3100T3G	1
D9, D10, D11, D12, D22, D23, D30, D31, D40, D41	Diodes - General Purpose, Power, Switching SS SWCH DIO 250V	onsemi	BAS21HT1G	10
D13, D14	Schottky DIODE 150V 15A TO-227A	VISHAY	V15PM15HM3/H	2
D15	Rectifiers 600V 1A Ultrafast	onsemi	MURS160T3	1
D17	Rectifiers 1.0 A Ultra Fast Recovery Rect	onsemi	ES1J	1

## CN190-1-5GPWR-REFZ 5G Second Stage Power Solution

TABLE 3. BOM List (2/3)

Designator	Description	Manufacturer	Mfg Part Number	QTY
D19	DIODE GEN PURP 1KV 1A SMA	Diodes	S1M/MB	1
FU1	Surface Mount Ceramic Fuse 60Vdc 50A	Bourns	SF-2923HC50C-2	1
J1, J5	45-SCREW CAPTIVATED TERMINAL	Keystone	7759	2
J2	45-SCREW CAPTIVATED TERMINAL	Keystone	7759	1
J4	45-SCREW CAPTIVATED TERMINAL	Keystone	7759	1
J9	FCI Header 0.1" pitch 2pos 1x2	FCI	67997-402HLF	1
L1, L2	WE-HCF 2818 6.8uH 47.5A 0.88mOhm	Würth	7443640680	2
L3	330uH Unshld 10% 1.1A 700mOhms	Coilcraft	DR0810-334L	1
Q1, Q2, Q7, Q8	OptiMOSTM5Power-Transistor,150V	Infineon	BSC093N15NS5	4
Q3, Q4, Q5, Q6, Q9, Q12	MOSFET N-CH 150V 50A TO252-3	Infineon	IPD200N15N3GATMA1	6
Q10, Q11	Not assembled			DNP
Q14, Q16	TRANS DIGITAL PNP+PNP	Diodes	DMMT5401	2
R1, R15, R17, R27, R55, R68, R88, R156, R157, R171, R172, R182, R183, R210, R211, R212, R213, R217, R218, R222, R223, R226, R251, R252	Not assembled			DNP
R2, R46, R87, R160, R161, R162	Chip Resistor Thick Film 0603 33K 1% 1/10W	YAGEO	RC0603FR-0733KL	6
R5	Chip Resistor Thick Film 0603 62K 1% 1/10W	YAGEO	RC0603FR-0762KL	1
R6, R10, R25, R29	Chip Resistor Thick Film 0603 1R 1% 1/10W	YAGEO	RC0603FR-071RL	4
R7	Chip Resistor Thick Film 1206 5R1 1% 250mW	Yageo	RC1206FR-075R1L	1
R8	Chip Resistor Thick Film 0603 20K 1% 1/10W	YAGEO	RC0603FR-0720KL	1
R11	Chip Resistor Thick Film 0603 5K1 1% 1/10W	YAGEO	RC0603FR-075K1L	1
R12	Chip Resistor Thick Film 0603 1K2 1% 1/10W	YAGEO	RC0603FR-071K2L	1
R13, R14, R21, R22	Chip Resistor Thick Film 1225 R002 2% 3W	Susumu	KRL6432E-C-R002-G-T1	4
R18	Chip Resistor Thick Film 0603 8K2 1% 1/10W	YAGEO	RC0603FR-078K2L	1
R19	Chip Resistor Thick Film 0603 169K 1% 1/10W	YAGEO	RC0603FR-07169KL	1
R20	Chip Resistor Thick Film 0603 2K7 1% 1/10W	YAGEO	RC0603FR-132K7L	1
R23, R112	Chip Resistor Thick Film 0603 100K 1% 1/10W	YAGEO	RC0603FR-07100KL	2
R26, R111	Chip Resistor Thick Film 0603 36K 1% 1/10W	YAGEO	RC0603FR-0736KL	2
R30, R31, R241	Chip Resistor Thick Film 0603 15K 1% 1/10W	YAGEO	RC0603FR-0715KL	3
R38, R39, R40	Chip Resistor Thick Film 0603 43K 1% 1/10W	YAGEO	RC0603FR-0743KL	3
R47	Chip Resistor Thick Film 0603 18K2 1% 1/10W	YAGEO	RC0603FR-0718K2L	1
R48, R190	Chip Resistor Thick Film 0603 1K82 1% 1/10W	YAGEO	RC0603FR-071K82L	2
R50, R51, R52, R53, R54, R58, R59, R60, R63, R64, R65, R66, R113, R150, R152, R165, R166, R169, R180, R181, R195, R214, R215, R230, R231, R250, R253	Chip Resistor Thick Film 0603 0R 1% 1/10W	YAGEO	RC0603FR-070RL	27

## CN190-1-5GPWR-REFZ 5G Second Stage Power Solution

**TABLE 3. BOM List (3/3)**

Designator	Description	Manufacturer	Mfg Part Number	QTY
R71, R73, R74	Chip Resistor Thick Film 0603 1K 1% 1/10W	YAGEO	RC0603FR-071KL	3
R72	Chip Resistor Thick Film 0603 470R 1% 1/10W	YAGEO	RC0603FR-07470RL	1
R90, R91, R92, R93	Chip Resistor Thick Film 0603 10R 1% 1/10W	YAGEO	RC0603FR-0710RL	4
R102	Chip Resistor Thick Film 1206 20R 1% 250mW	Yageo	RC1206FR-0720RL	1
R103, R163, R164	Chip Resistor Thick Film 0603 5K6 1% 1/10W	YAGEO	RC0603FR-075K6L	3
R114, R115, R173, R191, R192, R220, R221, R224, R225	Chip Resistor Thick Film 0603 10K 1% 1/10W	YAGEO	RC0603FR-0710KL	9
R137, R138, R139, R140	Chip Resistor Thick Film 0603 4K7 1% 1/10W	YAGEO	RC0603FR-074K7L	4
R154, R155	Chip Resistor Thick Film 0603 1K3 1% 1/10W	YAGEO	RC0603FR-071K3L	2
R167	Chip Resistor Thick Film 0603 499K 1% 1/10W	YAGEO	RC0603FR-07499KL	1
R168	Chip Resistor Thick Film 0603 30K 1% 1/10W	YAGEO	RC0603FR-0730KL	1
R184, R185	Chip Resistor Thick Film 0603 2R2 1% 1/10W	YAGEO	RC0603FR-072R2L	2
R193	Chip Resistor Thick Film 0603 120K 1% 1/10W	YAGEO	RC0603FR-07120KL	1
R194	Chip Resistor Thick Film 0603 39K 1% 1/10W	YAGEO	RC0603FR-0739KL	1
R205	DNP			1
R240	Chip Resistor Thick Film 0603 56K 1% 1/10W	YAGEO	RC0603FR-0756KL	1
R300	Chip Resistor Thick Film 0603 220K 1% 1/10W	YAGEO	RC0603FR-07220KL	1
S1	Push Button Switch 4.5 x 4.5mm 3.8mm High	C&K	PTS647SM38SMTR2 LFS	1
U1	80V Dual Synchronous Boost Controller	Renesas	ISL81805FRTZ-T	1
U2, U3	Fast, robust, dual-channel, functional and reinforced isolated MOSFET gate-driver with accurate and stable timing	Infineon	2EDF7275K	2
U4	700V AC/DC Buck Regulator with Ultra-Low Standby Power	Renesas	RAA2230114GP3	1
U5	Renesas RL78G1F 16-Bit 32MHz MCU LQFP48	Renesas	R5F11BGCAFB	1
U6	DUAL-Hot-Swappable 12C Isolators	ADI	ADuM1250	1
U8	150mA 20V Wide Input Voltage Range LDO Linear Regulator	Renesas	RAA2142204GP3	1
U9, U10	Not assembled			DNP



# CN190-1-5GPWR-REFZ 5G Second Stage Power Solution

## Board Layout

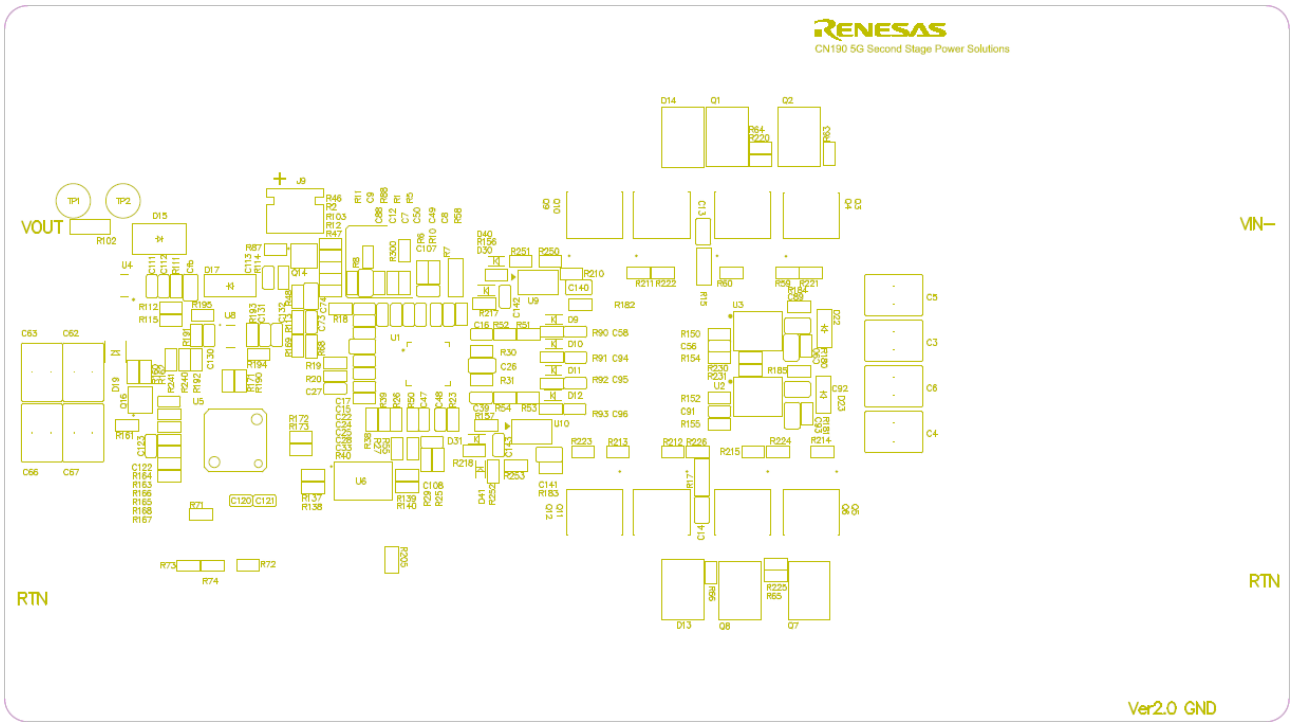

Figure 7 Silkscreen TOP

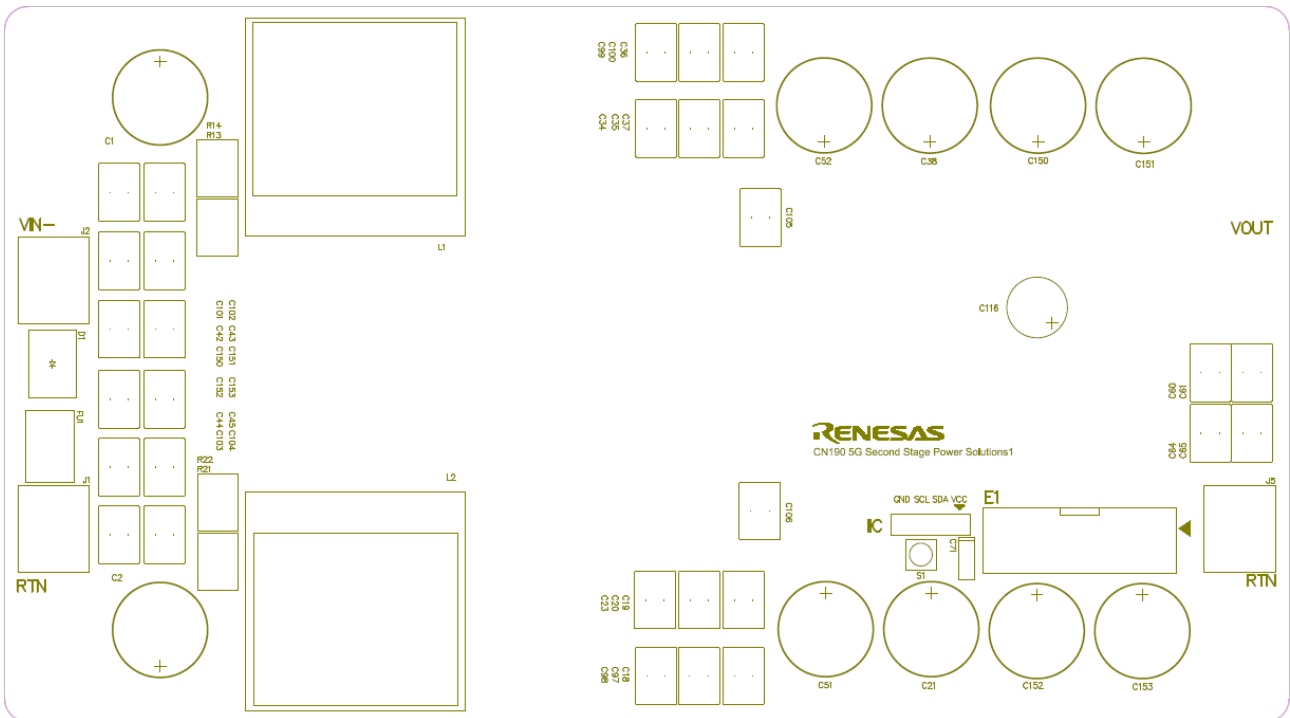

Figure 8 Silkscreen Bottom

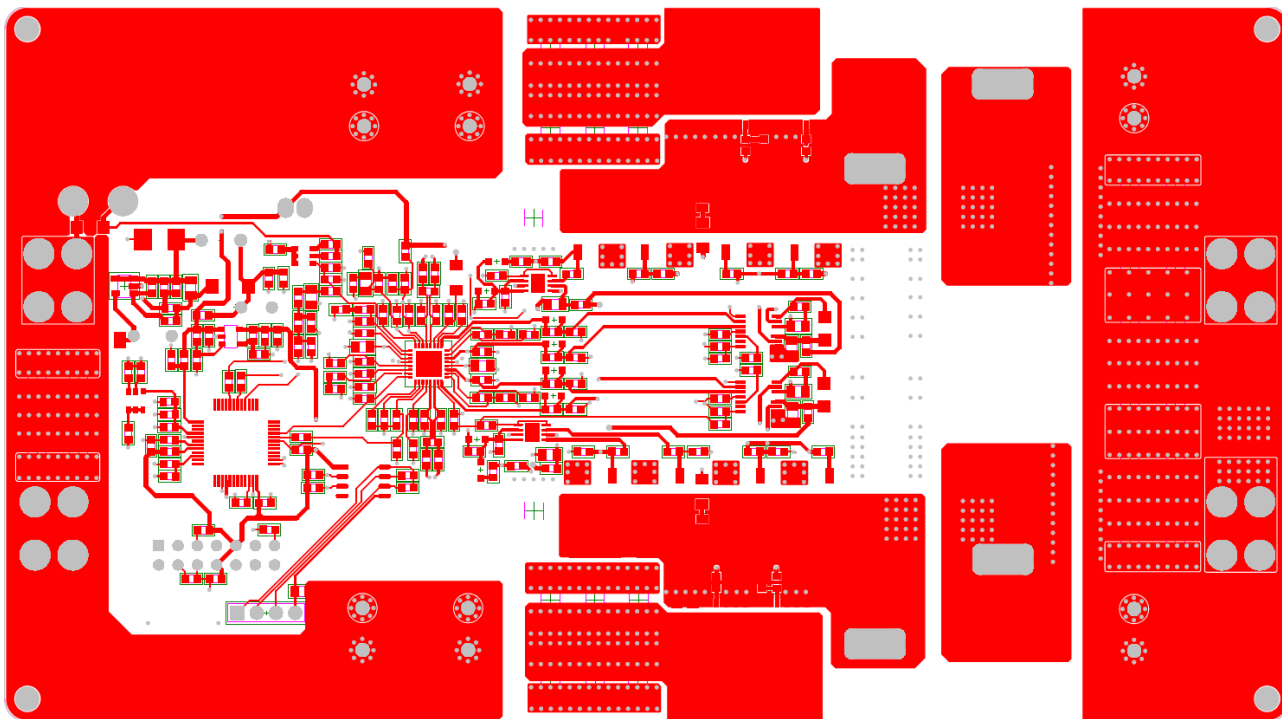

Figure 9 Top Layer

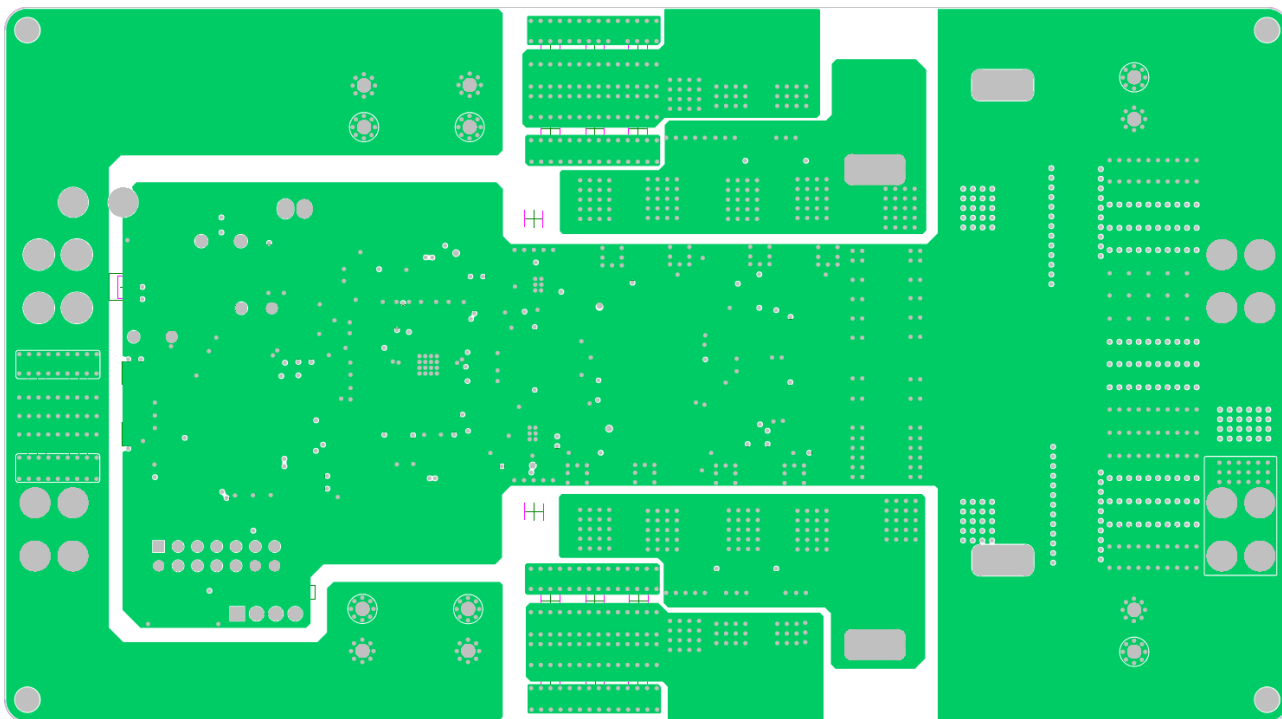

Figure 10 2 Layer

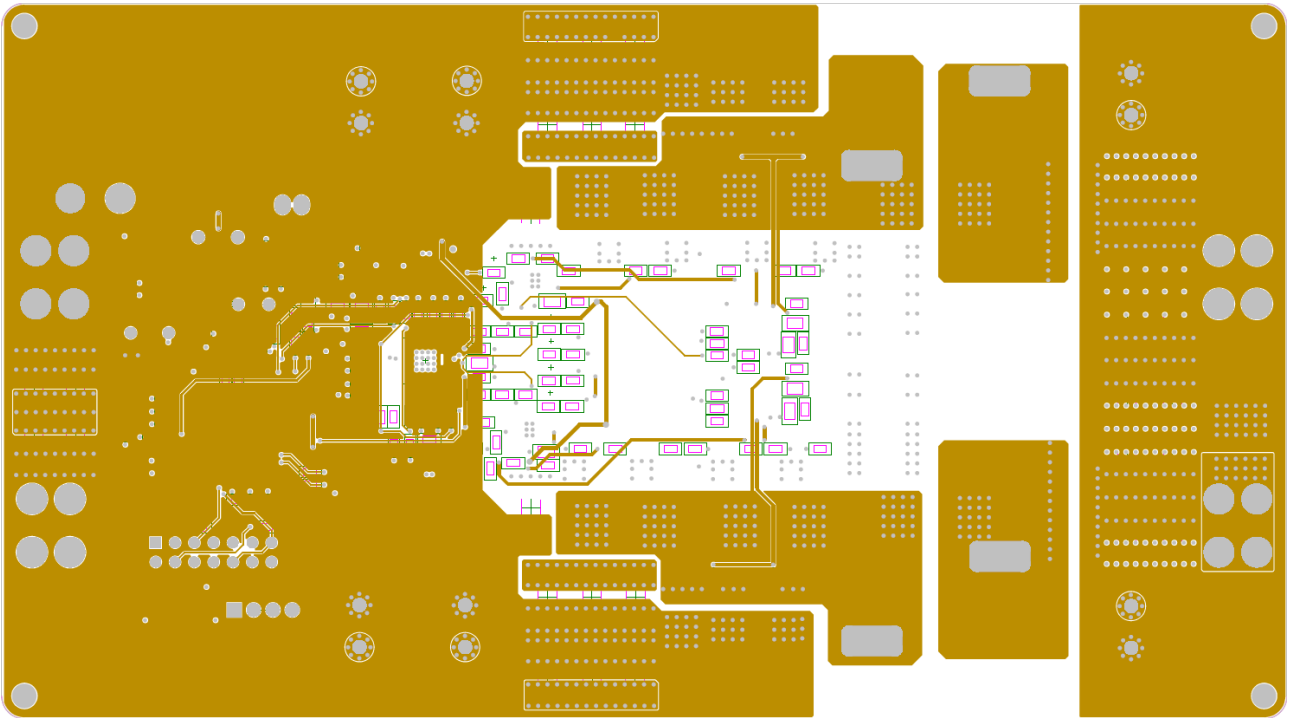

Figure 11 3 Layer

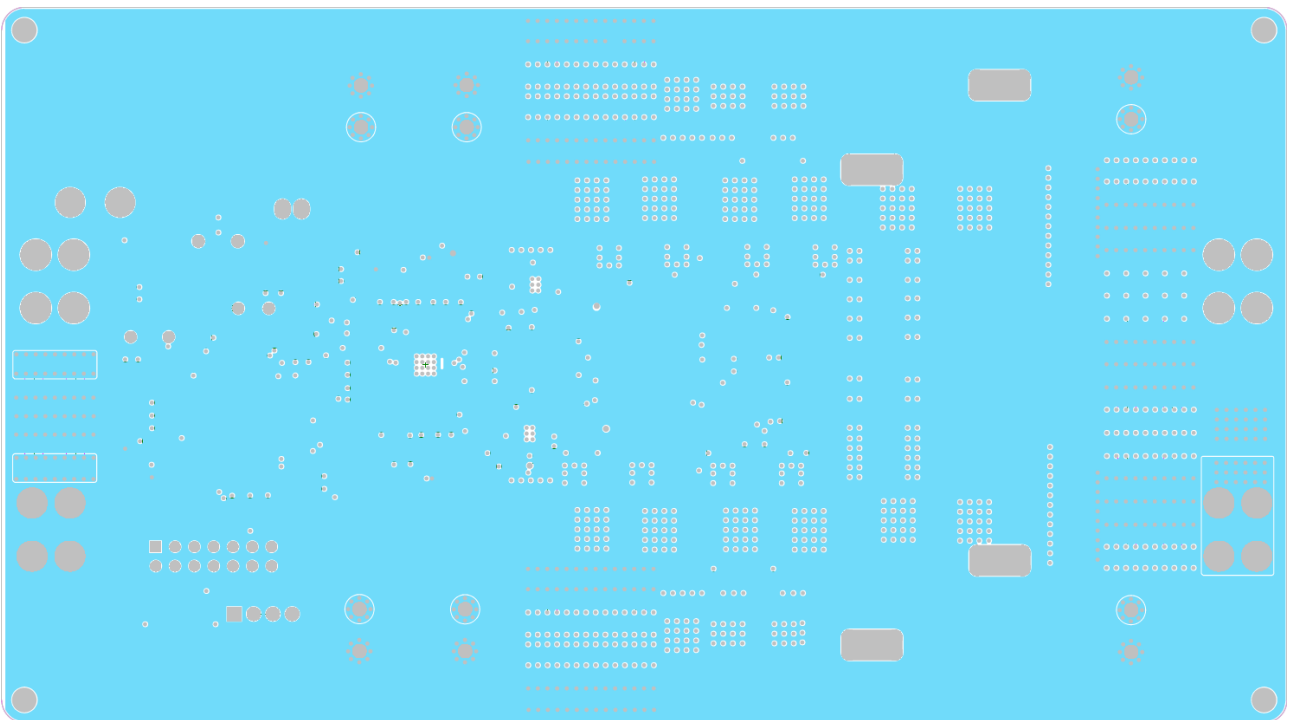

Figure 12 4 Layer

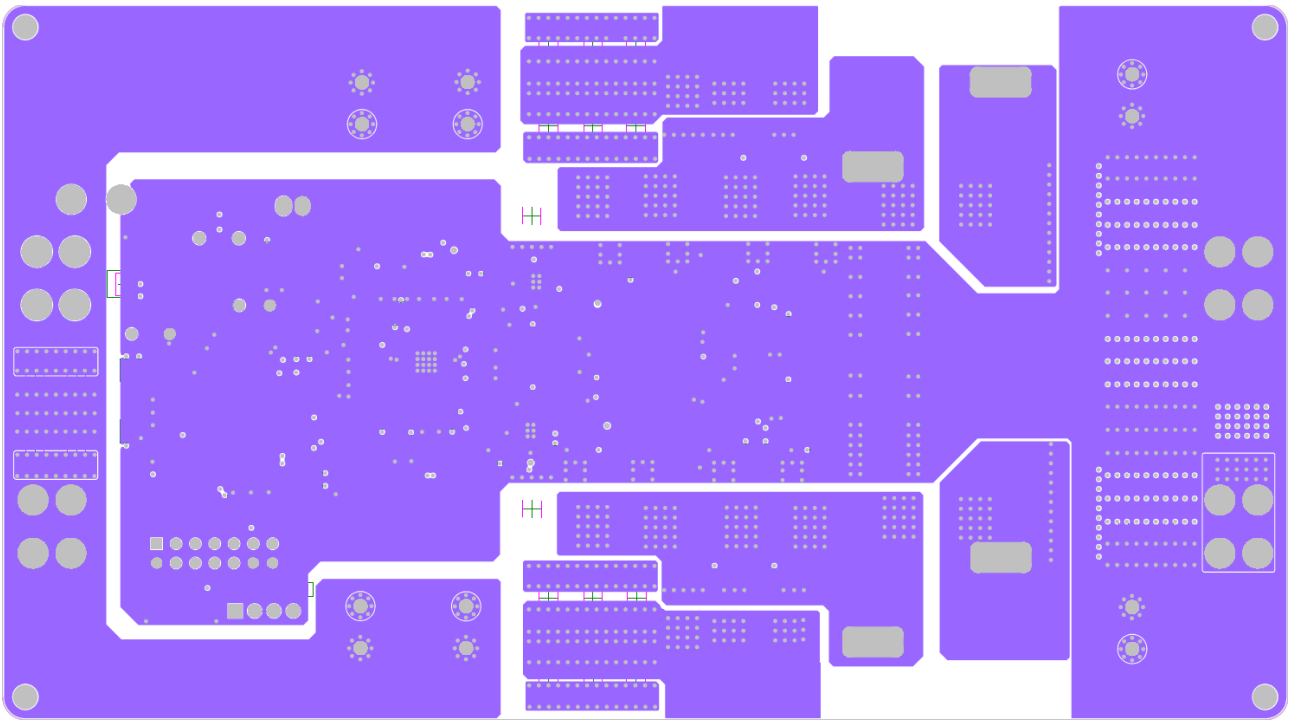

Figure 13 5 Layer

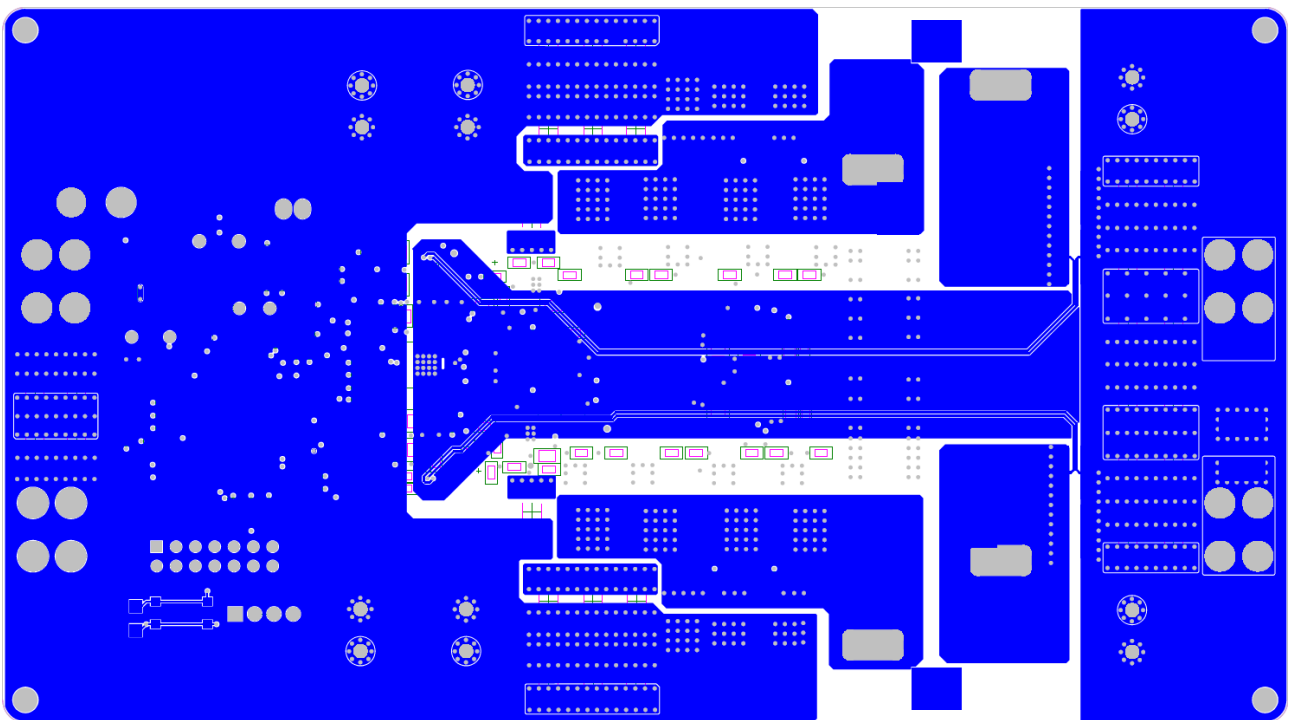

Figure 14 Bottom Layer

**Revision History**

Rev.	Date	Description	
		Page	Summary
1.0	Jan. 07, 2022	—	First edition issued

## General Precautions in the Handling of Micro processing Unit and Microcontroller Unit Products

The following usage notes are applicable to all Micro processing unit and Microcontroller unit products from Renesas. For detailed usage notes on the products covered by this document, refer to the relevant sections of the document as well as any technical updates that have been issued for the products.

### 1. Precaution against Electrostatic Discharge (ESD)

A strong electrical field, when exposed to a CMOS device, can cause destruction of the gate oxide and ultimately degrade the device operation. Steps must be taken to stop the generation of static electricity as much as possible, and quickly dissipate it when it occurs. Environmental control must be adequate. When it is dry, a humidifier should be used. This is recommended to avoid using insulators that can easily build up static electricity. Semiconductor devices must be stored and transported in an anti-static container, static shielding bag or conductive material. All test and measurement tools including work benches and floors must be grounded. The operator must also be grounded using a wrist strap. Semiconductor devices must not be touched with bare hands. Similar precautions must be taken for printed circuit boards with mounted semiconductor devices.

### 2. Processing at power-on

The state of the product is undefined at the time when power is supplied. The states of internal circuits in the LSI are indeterminate and the states of register settings and pins are undefined at the time when power is supplied. In a finished product where the reset signal is applied to the external reset pin, the states of pins are not guaranteed from the time when power is supplied until the reset process is completed. In a similar way, the states of pins in a product that is reset by an on-chip power-on reset function are not guaranteed from the time when power is supplied until the power reaches the level at which resetting is specified.

### 3. Input of signal during power-off state

Do not input signals or an I/O pull-up power supply while the device is powered off. The current injection that results from input of such a signal or I/O pull-up power supply may cause malfunction and the abnormal current that passes in the device at this time may cause degradation of internal elements. Follow the guideline for input signal during power-off state as described in your product documentation.

### 4. Handling of unused pins

Handle unused pins in accordance with the directions given under handling of unused pins in the manual. The input pins of CMOS products are generally in the high-impedance state. In operation with an unused pin in the open-circuit state, extra electromagnetic noise is induced near the LSI, an associated shoot-through current flows internally, and malfunctions occur due to the false recognition of the pin state as an input signal become possible.

### 5. Clock signals

After applying a reset, only release the reset line after the operating clock signal becomes stable. When switching the clock signal during program execution, wait until the target clock signal is stabilized. When the clock signal is generated with an external resonator or from an external oscillator during a reset, ensure that the reset line is only released after full stabilization of the clock signal. Additionally, when switching to a clock signal produced with an external resonator or by an external oscillator while program execution is in progress, wait until the target clock signal is stable.

### 6. Voltage application waveform at input pin

Waveform distortion due to input noise or a reflected wave may cause malfunction. If the input of the CMOS device stays in the area between  $V_{IL}$  (Max.) and  $V_{IH}$  (Min.) due to noise, for example, the device may malfunction. Take care to prevent chattering noise from entering the device when the input level is fixed, and also in the transition period when the input level passes through the area between  $V_{IL}$  (Max.) and  $V_{IH}$  (Min.).

### 7. Prohibition of access to reserved addresses

Access to reserved addresses is prohibited. The reserved addresses are provided for possible future expansion of functions. Do not access these addresses as the correct operation of the LSI is not guaranteed.

### 8. Differences between products

Before changing from one product to another, for example to a product with a different part number, confirm that the change will not lead to problems. The characteristics of a micro processing unit or microcontroller unit products in the same group but having a different part number might differ in terms of internal memory capacity, layout pattern, and other factors, which can affect the ranges of electrical characteristics, such as characteristic values, operating margins, immunity to noise, and amount of radiated noise. When changing to a product with a different part number, implement a system-evaluation test for the given product.

## Notice

1. Descriptions of circuits, software and other related information in this document are provided only to illustrate the operation of semiconductor products and application examples. You are fully responsible for the incorporation or any other use of the circuits, software, and information in the design of your product or system. Renesas Electronics disclaims any and all liability for any losses and damages incurred by you or third parties arising from the use of these circuits, software, or information.
2. Renesas Electronics hereby expressly disclaims any warranties against and liability for infringement or any other claims involving patents, copyrights, or other intellectual property rights of third parties, by or arising from the use of Renesas Electronics products or technical information described in this document, including but not limited to, the product data, drawings, charts, programs, algorithms, and application examples.
3. No license, express, implied or otherwise, is granted hereby under any patents, copyrights or other intellectual property rights of Renesas Electronics or others.
4. You shall not alter, modify, copy, or reverse engineer any Renesas Electronics product, whether in whole or in part. Renesas Electronics disclaims any and all liability for any losses or damages incurred by you or third parties arising from such alteration, modification, copying or reverse engineering.
5. Renesas Electronics products are classified according to the following two quality grades: "Standard" and "High Quality". The intended applications for each Renesas Electronics product depends on the product's quality grade, as indicated below.
  - "Standard": Computers; office equipment; communications equipment; test and measurement equipment; audio and visual equipment; home electronic appliances; machine tools; personal electronic equipment; industrial robots; etc.
  - "High Quality": Transportation equipment (automobiles, trains, ships, etc.); traffic control (traffic lights); large-scale communication equipment; key financial terminal systems; safety control equipment; etc.
- Unless expressly designated as a high reliability product or a product for harsh environments in a Renesas Electronics data sheet or other Renesas Electronics document, Renesas Electronics products are not intended or authorized for use in products or systems that may pose a direct threat to human life or bodily injury (artificial life support devices or systems; surgical implantations; etc.), or may cause serious property damage (space system; undersea repeaters; nuclear power control systems; aircraft control systems; key plant systems; military equipment; etc.). Renesas Electronics disclaims any and all liability for any damages or losses incurred by you or any third parties arising from the use of any Renesas Electronics product that is inconsistent with any Renesas Electronics data sheet, user's manual or other Renesas Electronics document.
6. When using Renesas Electronics products, refer to the latest product information (data sheets, user's manuals, application notes, "General Notes for Handling and Using Semiconductor Devices" in the reliability handbook, etc.), and ensure that usage conditions are within the ranges specified by Renesas Electronics with respect to maximum ratings, operating power supply voltage range, heat dissipation characteristics, installation, etc. Renesas Electronics disclaims any and all liability for any malfunctions, failure or accident arising out of the use of Renesas Electronics products outside of such specified ranges.
7. Although Renesas Electronics endeavors to improve the quality and reliability of Renesas Electronics products, semiconductor products have specific characteristics, such as the occurrence of failure at a certain rate and malfunctions under certain use conditions. Unless designated as a high reliability product or a product for harsh environments in a Renesas Electronics data sheet or other Renesas Electronics document, Renesas Electronics products are not subject to radiation resistance design. You are responsible for implementing safety measures to guard against the possibility of bodily injury, injury or damage caused by fire, and/or danger to the public in the event of a failure or malfunction of Renesas Electronics products, such as safety design for hardware and software, including but not limited to redundancy, fire control and malfunction prevention, appropriate treatment for aging degradation or any other appropriate measures. Because the evaluation of microcomputer software alone is very difficult and impractical, you are responsible for evaluating the safety of the final products or systems manufactured by you.
8. Please contact a Renesas Electronics sales office for details as to environmental matters such as the environmental compatibility of each Renesas Electronics product. You are responsible for carefully and sufficiently investigating applicable laws and regulations that regulate the inclusion or use of controlled substances, including without limitation, the EU RoHS Directive, and using Renesas Electronics products in compliance with all these applicable laws and regulations. Renesas Electronics disclaims any and all liability for damages or losses occurring as a result of your noncompliance with applicable laws and regulations.
9. Renesas Electronics products and technologies shall not be used for or incorporated into any products or systems whose manufacture, use, or sale is prohibited under any applicable domestic or foreign laws or regulations. You shall comply with any applicable export control laws and regulations promulgated and administered by the governments of any countries asserting jurisdiction over the parties or transactions.
10. It is the responsibility of the buyer or distributor of Renesas Electronics products, or any other party who distributes, disposes of, or otherwise sells or transfers the product to a third party, to notify such third party in advance of the contents and conditions set forth in this document.
11. This document shall not be reprinted, reproduced or duplicated in any form, in whole or in part, without prior written consent of Renesas Electronics.
12. Please contact a Renesas Electronics sales office if you have any questions regarding the information contained in this document or Renesas Electronics products.

(Note1) "Renesas Electronics" as used in this document means Renesas Electronics Corporation and also includes its directly or indirectly controlled subsidiaries.

(Note2) "Renesas Electronics product(s)" means any product developed or manufactured by or for Renesas Electronics.

(Rev.4.0-1 November 2017)

## Corporate Headquarters

TOYOSU FORESIA, 3-2-24 Toyosu,  
Koto-ku, Tokyo 135-0061, Japan  
[www.renesas.com](http://www.renesas.com)

## Trademarks

Renesas and the Renesas logo are trademarks of Renesas Electronics Corporation. All trademarks and registered trademarks are the property of their respective owners.

## Contact information

For further information on a product, technology, the most up-to-date version of a document, or your nearest sales office, please visit:  
[www.renesas.com/contact/](http://www.renesas.com/contact/).