

QCIOT056-ISL12022EVZ

RTC Pmod™ Board

The QCIOT056-ISL12022MAEVZ device is a low power real time clock (RTC) with an embedded temperature sensor and crystal. Device functions include oscillator compensation, clock/calendar, power fail and low battery monitors, brownout indicator, one-time, periodic or polled alarms, intelligent battery backup switching, Battery Reseal™ function and 128 bytes of battery-backed user SRAM. Backup battery current draw is less than 1.6µA over the temperature range. The RTC tracks time with separate registers for hours, minutes, and seconds. Daylight Savings time adjustment is done automatically, using parameters entered by the user. Power fail and battery monitors offer user-selectable trip levels.

The QCIOT056-ISL12022MAEVZ features Pmod™ connectors on both sides of the board to allow additional Type 6/6A boards to be connected in a daisy-chained solution with multiple sensors on the same MCU Pmod connector. Software support present in the Renesas IDE ([e2 studio](#)) provides code generation to connect the sensor and the MCU, thereby significantly reducing development time. With its standard connector and software support, the QCIOT056-ISL12022MAEVZ is ideal for Renesas [Quick-Connect IoT](#) to rapidly create an IoT system.

**Kit Contents**

- QCIOT056-ISL12022MA Pmod Board

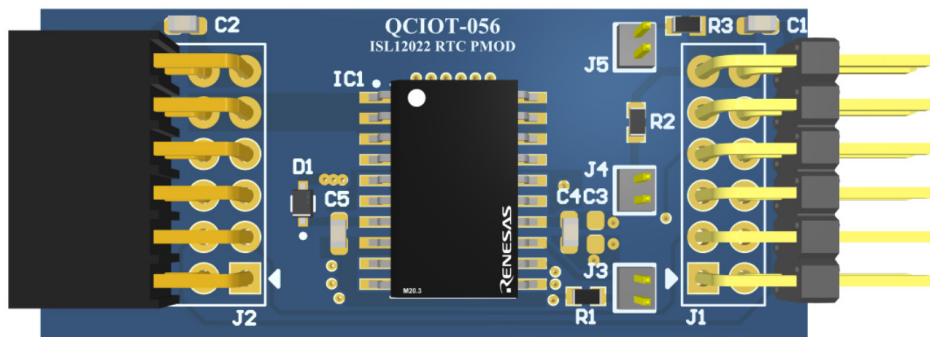

Figure 1. QCIOT056-ISL12022MAEVZ RTC Pmod Board

**Features**

- On-chip oscillator temperature compensation
- Embedded 32.768kHz quartz crystal in the package
- 10-bit digital temperature sensor output
- 15 selectable frequency outputs
- Interrupt for alarm or 15 selectable frequency outputs
- Automatic backup to battery or supercapacitor
- Standardized Type 6A Pmod connector supports I<sup>2</sup>C extended interface
- Dual connectors allow pass-through signals for daisy-chained solutions
- Software support in e2 studio minimizes development time with one-click code generation

**Related Documents**

- [ISL12022MA Datasheet](#)
- [Renesas Quick-Connect IoT Manual](#)

## Contents

<b>1. Functional Description</b> .....	<b>3</b>
1.1 Operating Environment.....	3
<b>2. Setup</b> .....	<b>4</b>
2.1 Required or Recommended User Equipment.....	4
2.2 Software Tools and Versions Required .....	4
2.3 Kit Hardware Connections .....	4
<b>3. Programming Interface</b> .....	<b>5</b>
<b>4. Board Design</b> .....	<b>9</b>
4.1 Application Schematic Diagram.....	9
4.2 Bill of Materials (BOM).....	10
4.3 Board Layout .....	11
<b>5. Ordering Information</b> .....	<b>11</b>
<b>6. Revision History</b> .....	<b>11</b>

## Figures

Figure 1. QCIOT056-ISL12022MAEVZ RTC Pmod Board.....	1
Figure 2. Evaluation Kit Connections using the QCIOT056-ISL12022MAEVZ and EK-RA6M4 .....	3
Figure 3. Evaluation Kit Connections.....	5
Figure 4. Debugging the Board .....	6
Figure 5. Steps for Flashing and Flash Programmer Settings.....	7
Figure 6. J-Link Terminal Window – Serial Data Output.....	8
Figure 7. QCIOT056-ISL12022MAEVZ RTC Pmod Board (Top) .....	9
Figure 8. Application Schematic.....	9
Figure 9. Silkscreen Top.....	11
Figure 10. Silkscreen Bottom .....	11
Figure 11. Copper Top .....	11
Figure 12. Copper Bottom .....	11
Figure 13. Internal Plane-1 (GND).....	11
Figure 14. Internal Plane-2 (PWR) .....	11

# 1. Functional Description

The QCIOT056-ISL12022MAEVZ functions as an external Real Time Clock (RTC) converter building block to create a custom system solution. Use the board individually or with a combination of other sensors by using the Pmod Type 6A interface (see the Renesas [Quick-Connect IoT](#) web page for a list of available Pmod sensors boards.)

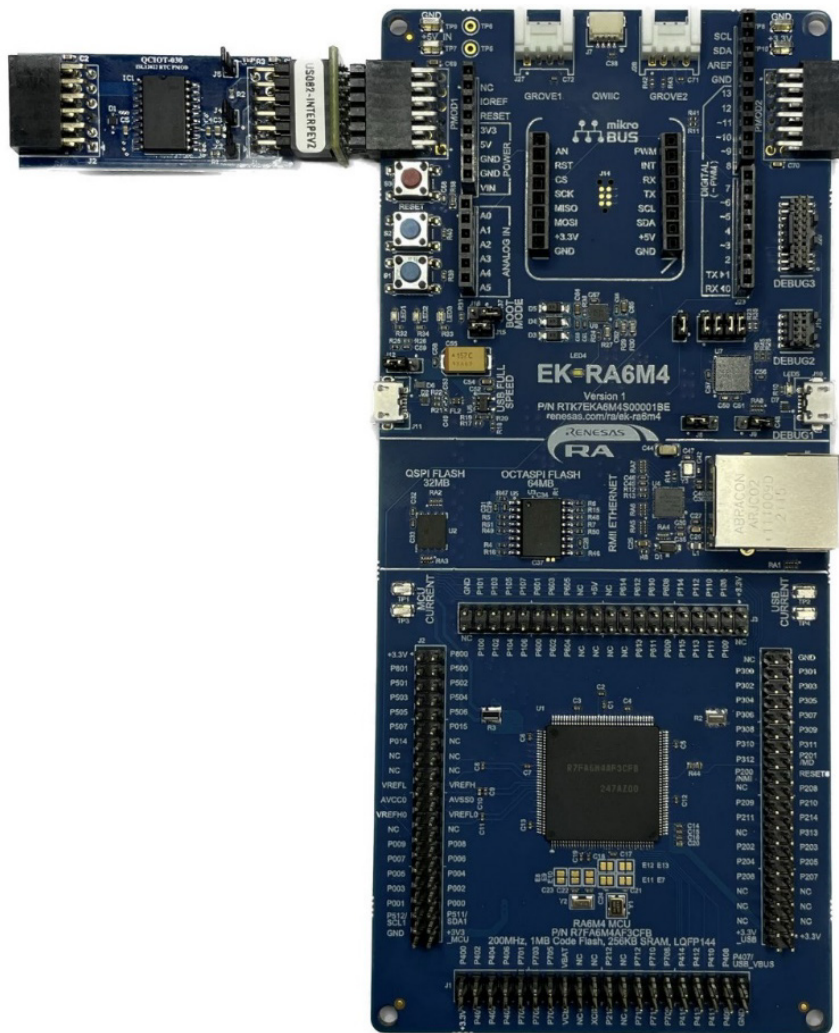

Figure 2. Evaluation Kit Connections using the QCIOT056-ISL12022MAEVZ and EK-RA6M4

## 1.1 Operating Environment

The operation of this software project has been confirmed with the following environment.

Table 1. Operating Environment

Item	Description
Demonstration Board	RTK7EKA6M4S00001BE ( <a href="#">EK-RA6M4</a> )
Microcontroller	RA6M4
Operating Frequency	48MHz
Operating Voltage	+3.3V
Integrated Development Environment	e2 Studio 2023-04

Item	Description
C-compiler	GCC 10.3.1.20210824
Flexible Software Package (FSP)	v3.3.0
RTOS	N/A
Emulator	On-board (J-LINK)
Interposer Board	Interposer Board to convert Type2/3 to Type 6A Pmod standard ( <a href="#">US082-INTERPEVZ</a> )
RTC Board	QCIOT056-ISL12022MAEVZ Pmod Board

## 2. Setup

### 2.1 Required or Recommended User Equipment

The following additional lab equipment (sold separately) is required for using the board:

- Any MCU/MPU board that supports Type 6A Pmods
- The [US082-INTERPEVZ](#) interposer board when using one of the Renesas MCU kits shown in [Table 2](#)

**Table 2. MCU Evaluation Kits Capable of Supporting Type 6A Pmods when used with the QCIOT056-ISL12022MAEVZ**

RA	RX	Synergy
EK-RA2A1	RX111-Starter-Kit	PK-S5D9
EK-RA4M1	RX231-Starter-Kit	DK-S3A7
EK-RA4W1	RX23W-Starter-Kit	DK-S128
EK-RA6M1	RX23T-Starter-Kit	TB-S1JA
EK-RA6M2	RX24T-Starter-Kit	TB-S3A6
EK-RA6M3	RX24U-Starter-Kit	DK-S7G2
EK-RA6M3G		

*Note:* This table is not a comprehensive list of supported MCU Kits. See the evaluation kit hardware manual to confirm Pmod pinout.

### 2.2 Software Tools and Versions Required

SST software tool is available by request, which includes raw lux data collecting demo.

*Note:* Only RZ solution is available now. Other MCU software is in development.

For more information about creating a customized system solution, see the [Quick-Connect IoT](#) web page.

### 2.3 Kit Hardware Connections

Use the following procedures to set up the kit.

1. Ensure the MCU evaluation kit being used has a Pmod connector set to Type 6A (refer to the kit hardware manual to confirm).
  - a. If no Type 6A Pmod is available, ensure the MCU evaluation kit can use the Pmod interposer board and insert the board into the MCU connector before adding any sensor boards.
2. Plug in the QCIOT056-ISL12022MAEVZ to the Type 6A connector, taking care to align Pin 1 on the sensor board and MCU kit.

3. Connect the J3, J4 and J5 jumpers to place 1kΩ pull-up resistors on the IRQ and I<sup>2</sup>C bus lines.
  - a. Only one set of pull-up resistors should be used on the I<sup>2</sup>C bus lines. If multiple sensor boards are used, only one board should have the jumpers present.
  - b. MCU kits typically do not have pull-up resistors present on these lines. Ensure to check for them.
4. The sensor is now ready to be used in the system. Follow the MCU kit instructions for connecting and powering up the evaluation kit.

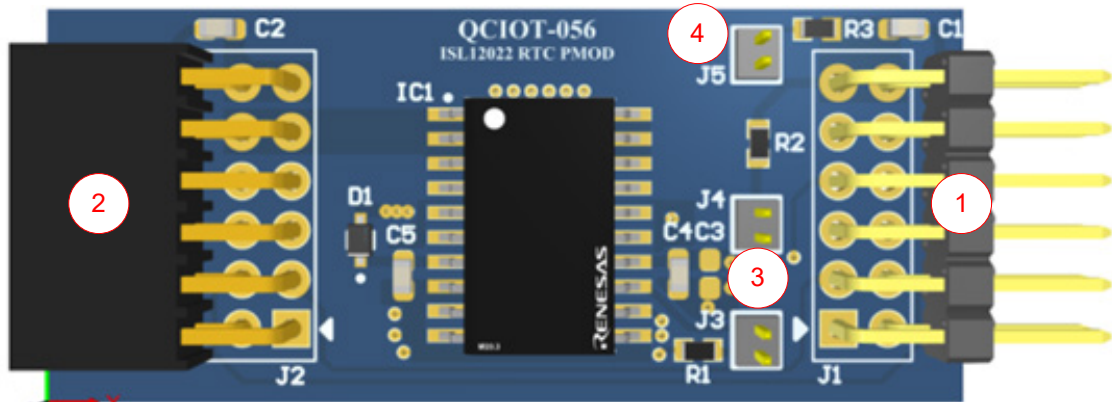

Figure 3. Evaluation Kit Connections

Number	Function
1	Connect to Board
2	Other Pmod connects here
3	I <sup>2</sup> C pull-up BUS
4	IRQ pull-up

### 3. Programming Interface

Programming of the system is accomplished through the Renesas IDE, [e2 studio](#). To set up the initial project in e2 studio, see the MCU evaluation kit documentation. As the project is initialized, adding the ISL76683 sensor to the project only takes a few steps.

1. Project settings, configuration, and Source code building:  
 IDE environment used for code development is e2-studio, and Toolchain is Renesas CCRL. [Figure 4](#) shows the screenshots and steps to debug the board for the first time.

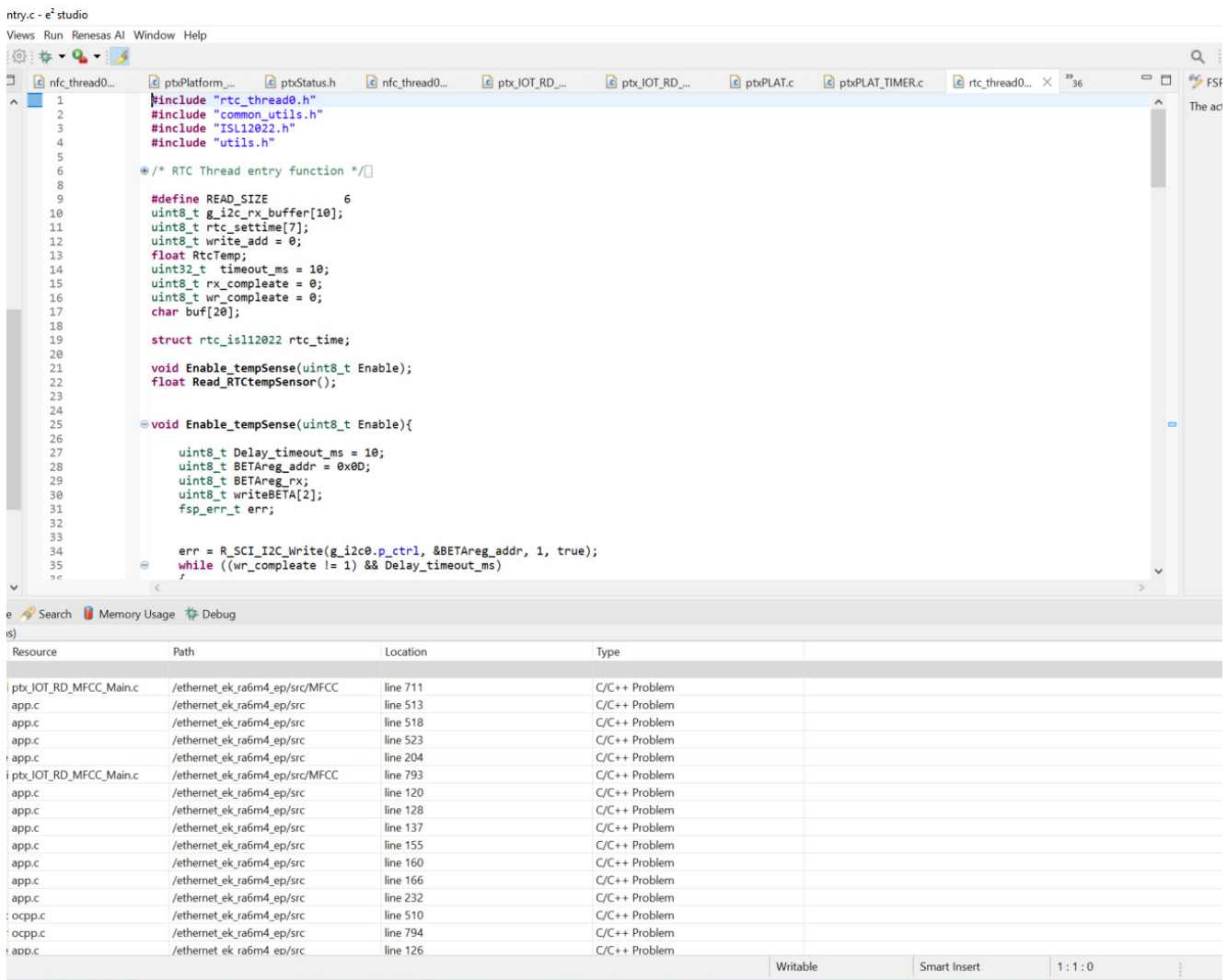
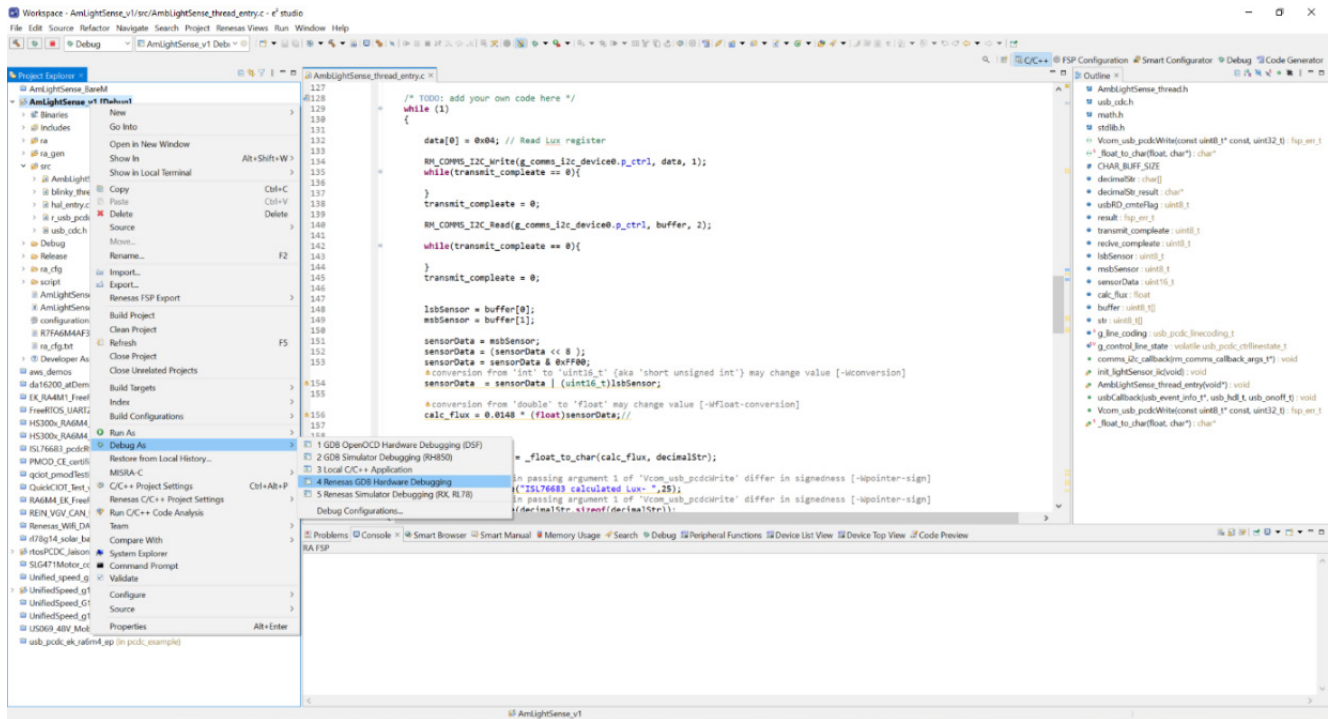

Figure 4. Debugging the Board

2. Flashing and Flash Programmer Settings (see Figure 5):

Tool: E2 Emulator Lite, Speed Setting: 9600

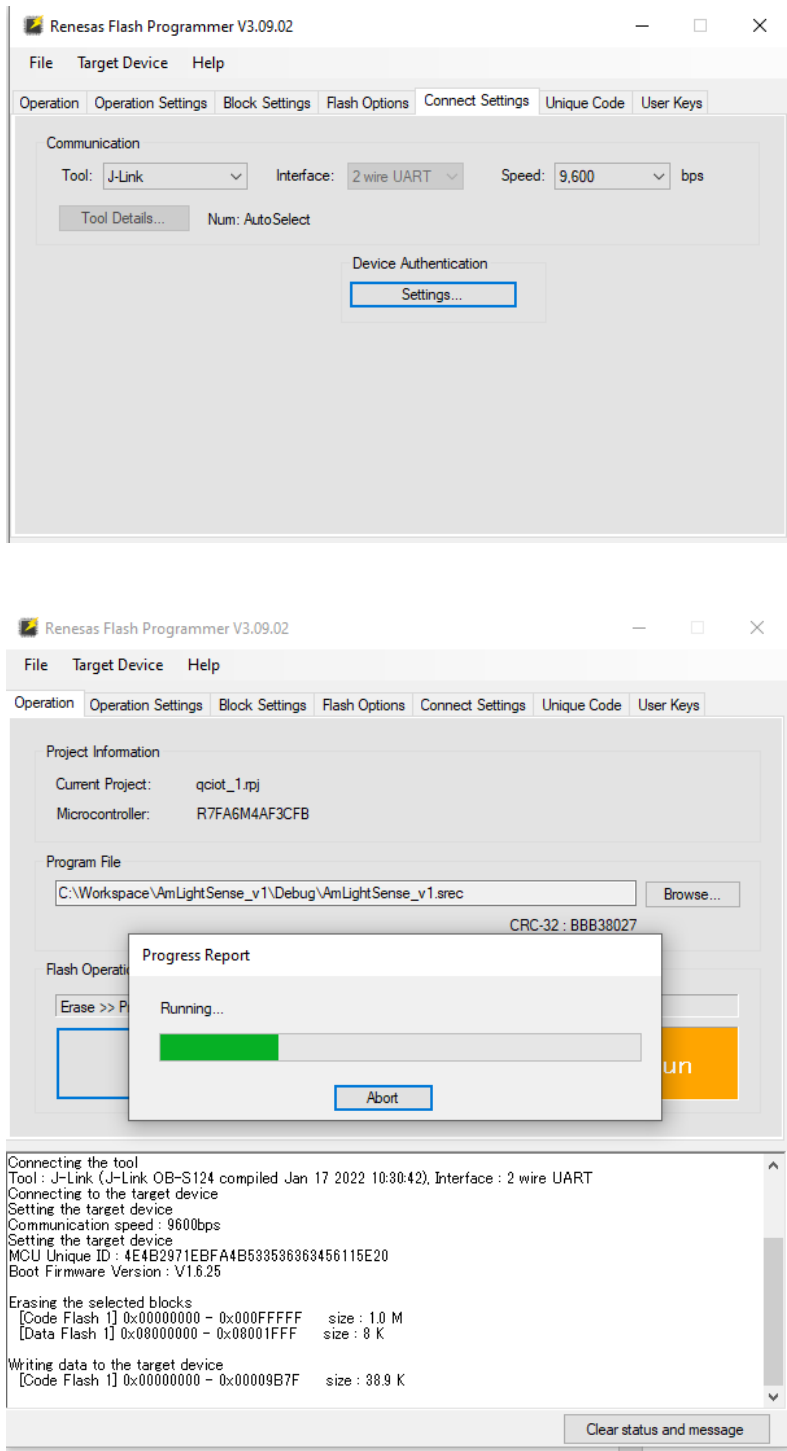

Figure 5. Steps for Flashing and Flash Programmer Settings

3. After debug is complete, the lux data can be viewed from the Tera Term software as shown in the [Figure 6](#).

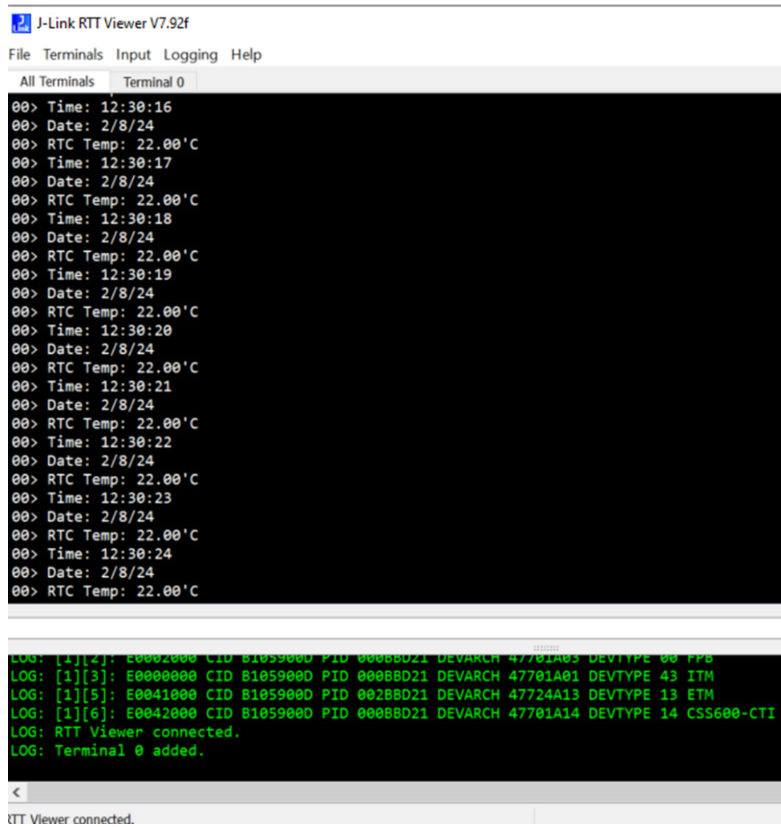

Figure 6. J-Link Terminal Window – Serial Data Output



## 4. Board Design

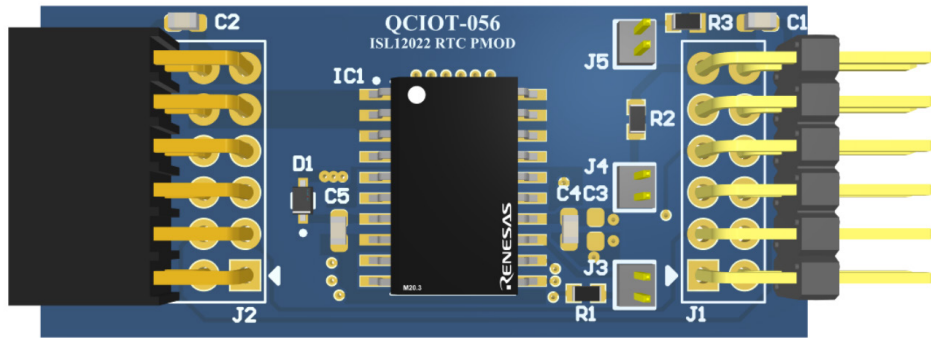

Figure 7. QCIOT056-ISL12022MAEVZ RTC Pmod Board (Top)

### 4.1 Application Schematic Diagram

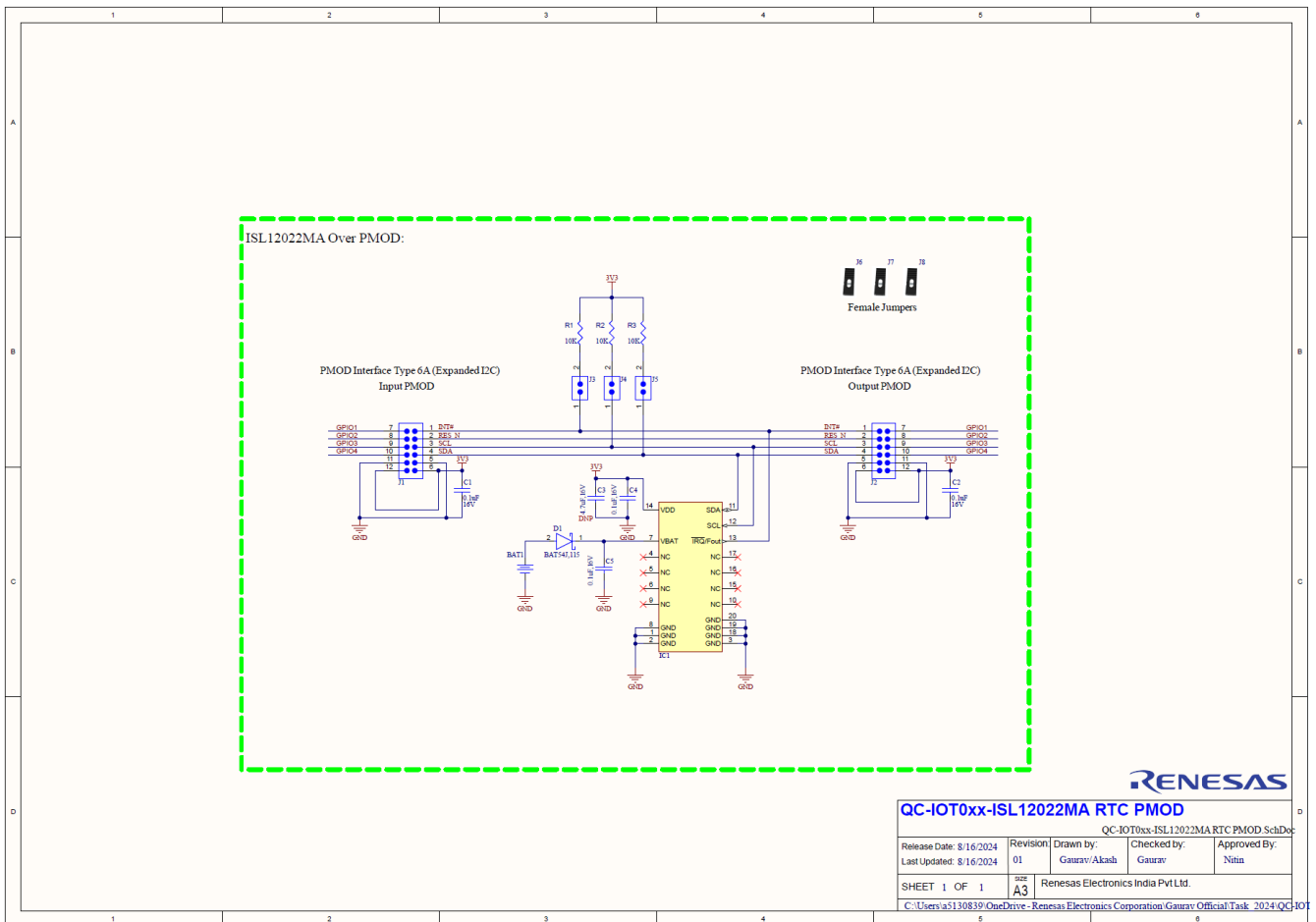

Figure 8. Application Schematic

## 4.2 Bill of Materials (BOM)

Qty	Reference Designator	Description	Manufacturer	Manufacturer Part Number
1	BAT1	Keystone CR1220 Battery Coin Cell holder	Keystone Electronics	3000TR
2	C1, C2	0.1 $\mu$ F $\pm$ 10% 16V Ceramic Capacitor X7R 0603 (1608 Metric)	Würth Elektronik	885012206046
0	C3	4.7 $\mu$ F $\pm$ 10% 16V Ceramic Capacitor X7R 0603 (1608 Metric)	Würth Elektronik	CC0603KRX5R7BB475
2	C4, C5	0.1 $\mu$ F $\pm$ 10% 16V Ceramic Capacitor X7R 0603 (1608 Metric)	Würth Elektronik	885012206046
1	D1	DIODE SCHOTTKY 30V 200MA SOD323F	Nexperia USA Inc.	BAT54J,115
1	IC1	Real Time Clock (RTC) IC Clock/Calendar 128B I2C, 2-Wire Serial 20-SOIC (0.295", 7.50mm Width)	Renesas	ISL12022MAIBZ
1	J1	Connector Header Through Hole, Right Angle 12 Position 0.100" (2.54mm)	Würth Elektronik	61301221021
1	J2	12 Position Receptacle Connector 0.100" (2.54mm) Through Hole, Right Angle Gold	Würth Elektronik	613012243121
3	J3, J4, J5	CONN HEADER VERT 2POS 1.27 MM	Samtec Inc.	FTS-102-01-L-S
3	J6, J7, J8	2 (1 $\times$ 2) Position Shunt Connector Black Closed Top, Grip 0.050" (1.27mm) Gold	Harwin Inc.	M50-2000005
3	R1, R2, R3	Chip Resistor, 10kOhm, $\pm$ 1%, 01W, -55 to 155 $^{\circ}$ C, 0603 (1608 Metric)	YAGEO	RC0603FR-0710KL

### 4.3 Board Layout

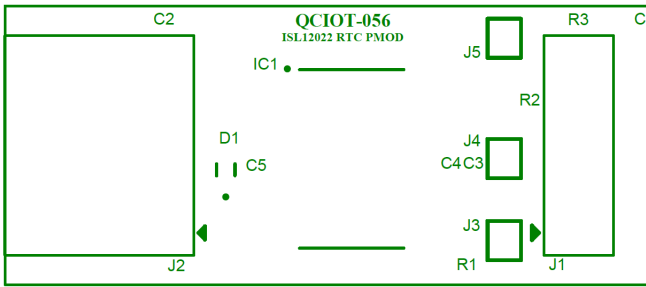

Figure 9. Silkscreen Top



Figure 10. Silkscreen Bottom

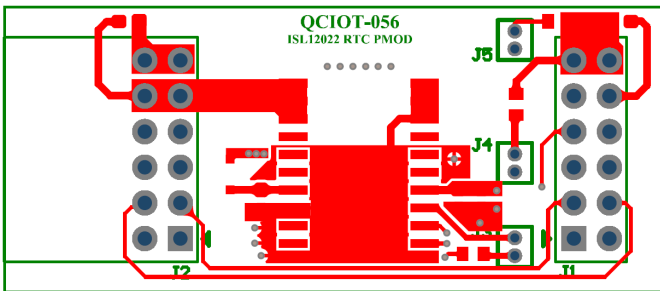

Figure 11. Copper Top

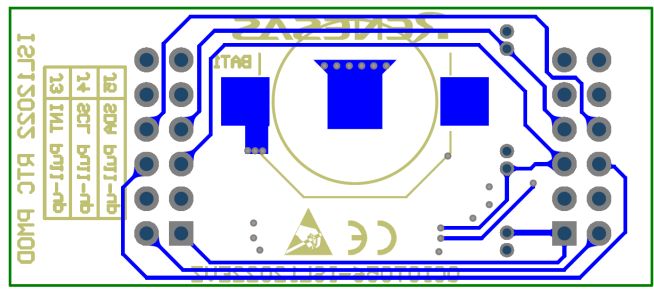

Figure 12. Copper Bottom

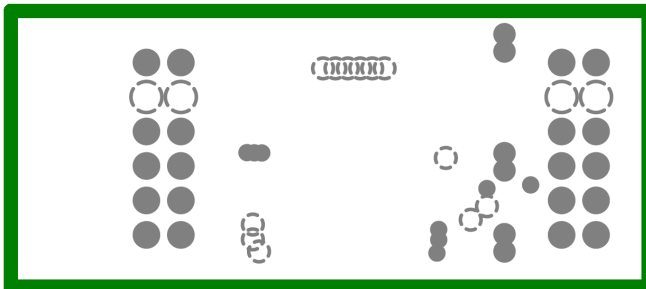

Figure 13. Internal Plane-1 (GND)

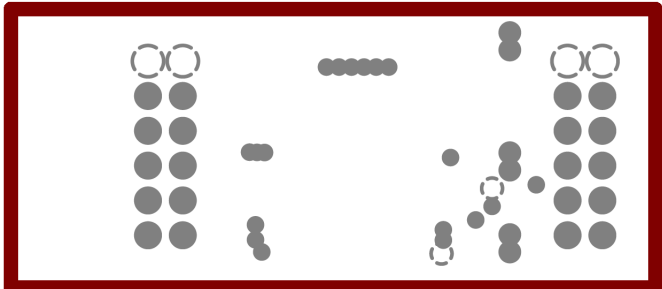

Figure 14. Internal Plane-2 (PWR)

## 5. Ordering Information

Part Number	Description
QCIOT056-ISL12022MAEVZ	ISL12022MA RTC Pmod Board
US082-INTERPEVZ	PMOD™ interposer board to convert Type 2A and 3A to Type 6A on older Renesas MCU kits

## 6. Revision History

Revision	Date	Description
1.00	Oct 22, 2024	Initial release.