

QCIOT31-ZMID4200POCZ

Sensor Pmod™ Board

Description

The QCIOT31-ZMID4200POCZ Board enables quick prototyping of the [ZMID4200](#) PWM-to-Digital Output Sensor for a custom system design. The ZMID4200 is an inductive position sensor IC with PWM, used for absolute rotary and linear motion sensing. The board provides a standard Pmod™ Type 6A (Extended I<sup>2</sup>C) connection for the on-board sensor to plug into any MCU evaluation kit with a matching connector.

The QCIOT31-ZMID4200POCZ features Pmod connectors on both sides of the board to allow additional Type 6/6A boards to be connected in a daisy-chained solution with multiple sensors on the same MCU/MPU Pmod connector. Software support present in the Renesas IDE ([e2 studio](#)) provides code generation to connect the sensor and the MCU, thereby significantly reducing development time. With its standard connector and software support, the QCIOT31-ZMID4200POCZ is ideal for Renesas [Quick-Connect IoT](#) to rapidly create an IoT system.

Kit Contents

- QCIOT31-ZMID4200POCZ Sensor Pmod Board

Features

- Inductive principle
- PWM output with programmable limits
- Overvoltage, reverse polarity, ESD and short circuit protection
- 10-bit resolution (PWM)
- Standardized Type 6A Pmod connector supports I<sup>2</sup>C Extended interface
- Dual connectors allow pass-through signals for daisy-chained solutions
- Software support in e2 studio minimizes development time with one-click code generation

Related Documents

- [ZMID4200 Datasheet](#)
- [ZMID4200 EVK User Manual](#)
- [Renesas Quick-Connect IoT Manual](#)

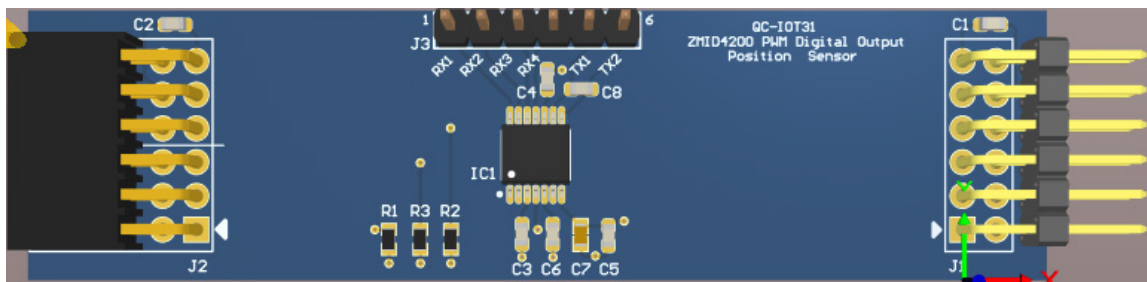

Figure 1. QCIOT31-ZMID4200POCZ Sensor Pmod Board

## Contents

<b>1. Functional Description</b> .....	<b>3</b>
1.1 Operating Environment.....	3
<b>2. Setup</b> .....	<b>4</b>
2.1 Required or Recommended User Equipment.....	4
2.2 Required Software Tools and Versions .....	4
2.2.1 Connection Setup between QC10T31-ZMID4200POCZ and ZMID4200STKI.....	5
2.2.2 Calibrating the ZMID4200 IC.....	5
2.3 Board Hardware Assembly.....	5
2.4 Kit Hardware Connections.....	6
<b>3. Programming Interface</b> .....	<b>7</b>
<b>4. Board Design</b> .....	<b>8</b>
4.1 Schematic Diagram .....	8
4.2 Bill of Materials (BOM).....	8
4.2.1 Pmod Base Board BOM .....	8
4.2.2 Coil Daughter Card Board BOM.....	9
4.3 Board Layout .....	10
4.3.1 Pmod Base Board Layout .....	10
4.3.2 Coil Daughter Card Board Layout .....	10
4.3.3 Metal Contact Board Layout.....	11
<b>5. Ordering Information</b> .....	<b>11</b>
<b>6. Revision History</b> .....	<b>11</b>

## Figures

Figure 1. QC10T31-ZMID4200POCZ Sensor Pmod Board.....	1
Figure 2. Evaluation Kit Connections using of QC10T31-ZMID4200POCZ with EK-RA6M4.....	3
Figure 3. Calibration GUI.....	4
Figure 4. QC10T31-ZMID4200POCZ and ZMID4200STKI Hardware Setup.....	5
Figure 5. QC10T31 Hardware Setup with Linear Coil.....	6
Figure 6. Evaluation Kit Connections.....	6
Figure 7. Debugging the Board .....	7
Figure 8. Application Schematic Diagram.....	8
Figure 9. Top Layer .....	10
Figure 10. Bottom Layer .....	10
Figure 11. Internal Plane-1 (GND).....	10
Figure 12. Internal Plane-2 (PWR) .....	10
Figure 13. Top Layer .....	10
Figure 14. Bottom Layer .....	10
Figure 15. Internal Plane-1 .....	10
Figure 16. Internal Plane-2 (PWR) .....	10
Figure 17. Top Layer .....	11
Figure 18. Bottom Layer .....	11

# 1. Functional Description

The QCIOT31-ZMID4200POCZ functions as PWM-to-Digital Output Sensor converter building block to create a custom system solution. Use the board individually or with a combination of other sensors by using the Pmod Type 6A interface (for a list of available sensors Pmod boards, see the Renesas [Quick-Connect IoT](#) web page).

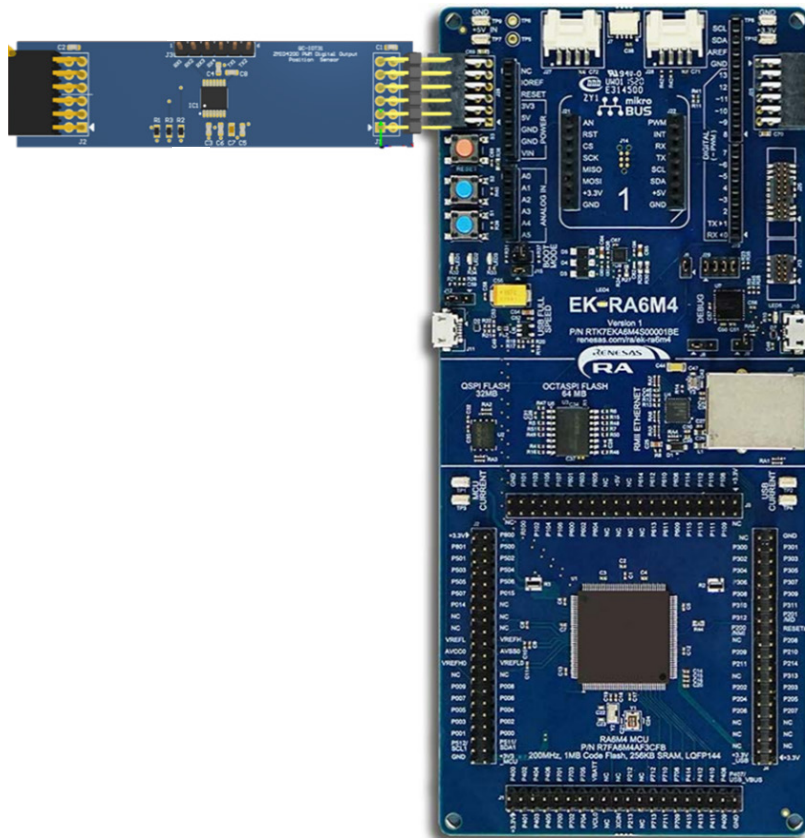

Figure 2. Evaluation Kit Connections using of QCIOT31-ZMID4200POCZ with EK-RA6M4

## 1.1 Operating Environment

The operation of this software project has been confirmed with the following environment.

Table 1. Operating Environment

Item	Description
Demonstration Board	RTK7EKA6M4S00001BE ( <a href="#">EK-RA6M4</a> )
Microcontroller	RA6M4
Operating Frequency	48MHz
Operating Voltage	+5V
Integrated Development Environment	e2 Studio 2023-04
C-compiler	GCC 10.3.1.20210824
Flexible Software Package (FSP)	v3.3.0
RTOS	N/A
Emulator	On board (J-LINK)
Sensor Board	QCIOT31-ZMID4200POCZ Pmod Board

## 2. Setup

### 2.1 Required or Recommended User Equipment

The following additional lab equipment (sold separately) is required for using the board:

- Any MCU/MPU board that supports Type 6A Pmods
- [ZMID4200STKIT](#) Inductive Position Sensing Starter Kit
- [US082-INTERPEVZ](#) interposer board when using one of the Renesas MCU kits shown in [Table 2](#)

**Table 2. MCU Evaluation Kits Capable of Supporting Type 6A Pmods when used with the QCIOT31-ZMID4200POCZ**

RA	RX	Synergy
EK-RA4W1	RX111-Starter-Kit	PK-S5D9
EK-RA2A1	RX231-Starter-Kit	DK-S3A7
EK-RA4M1	RX23W-Starter-Kit	DK-S128
EK-RA6M1	RX23T-Starter-Kit	TB-S1JA
EK-RA6M2	RX24T-Starter-Kit	TB-S3A6
EK-RA6M3	RX24U-Starter-Kit	DK-S7G2
EK-RA6M3G		

*Note:* This table is not a comprehensive list of supported MCU Kits. See the evaluation kit hardware manual to confirm the Pmod pinout.

### 2.2 Required Software Tools and Versions

The tool to calibrate ZMID4200 ICs is called “ZMID4200 EVKIT Application”. Open the [ZMID4200STKIT](#) product page, go to the section “Design & Development > Software Downloads” and download the *ZMID4200 Starter Kit Software*.

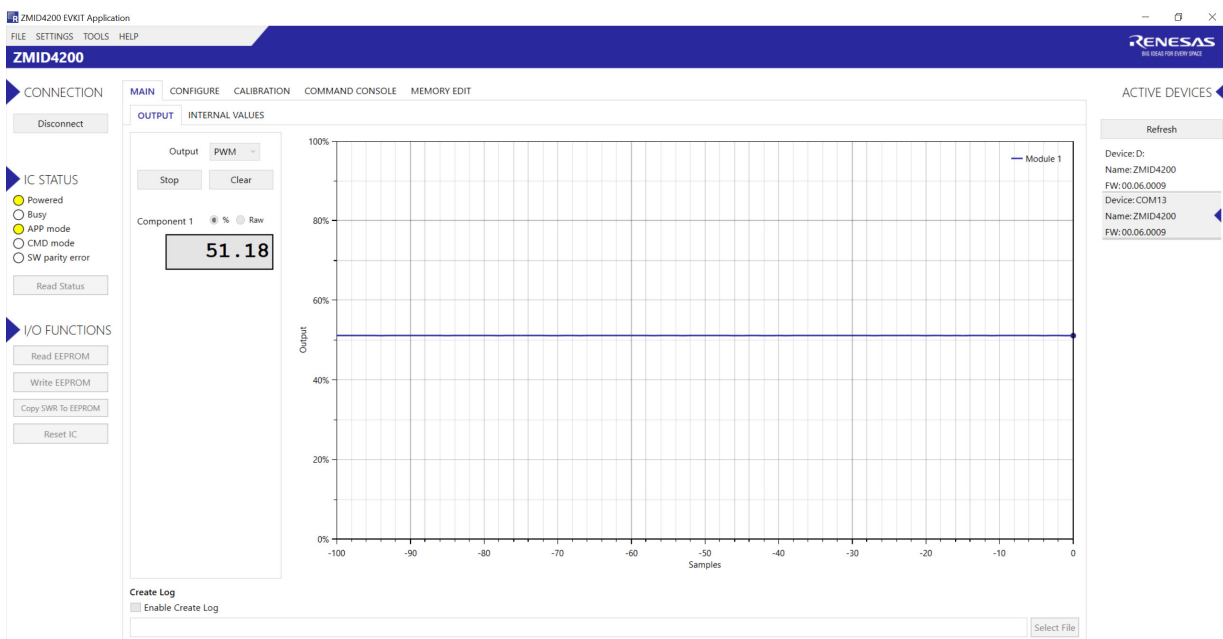

**Figure 3. Calibration GUI**



Figure 4. QCIOT31-ZMID4200POCZ and ZMID4200STKI Hardware Setup

### 2.2.1 Connection Setup between QCIOT31-ZMID4200POCZ and ZMID4200STKI

To establish a connection between the two boards, connect the P1 connector on Starter kit with the J1 connector on QCIOT31 board as per shown below:

ZMID4200STKI (P1)			QCIOT31-ZMID4200POCZ (J1)	
Pin Number	Pin Name		Pin Number	Pin Name
Pin 1	VDD	→	Pins 6/12	5V0
Pin 2	Out1	→	Pin 1	IRQ
Pin 3	GND	→	Pins 5/11	GND

### 2.2.2 Calibrating the ZMID4200 IC

1. Connect the *ZMID4200STKI Inductive Position Sensing Starter Kit* with the PC on which the above application is installed (see [Figure 3](#)).
2. After opening the application, click on the “refresh” button on the top right corner. The new device will appear under the refresh button.
3. Select that device and click on the *Connect* button on the top left side.
4. After the successful connection, the window appears as shown in [Figure 3](#).
5. After a successful connection, calibrate the device by following the steps in “Calibrations > Output Range > Start Calibration”.

## 2.3 Board Hardware Assembly

There are a total of 3 boards for the QCIOT31-ZMID4200POCZ kit assembly:

1. QCIOT31 Pmod Base Board.
2. Coil Daughter Card Board.
3. Metallic Contact Board.

Assemble as shown in [Figure 5](#).



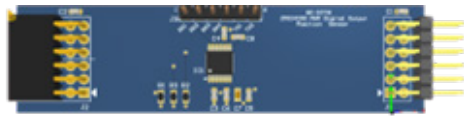

1. QC-IOT31 PMOD Base Board



2. Coil Daughter Card Board



3. Metallic Contact Board

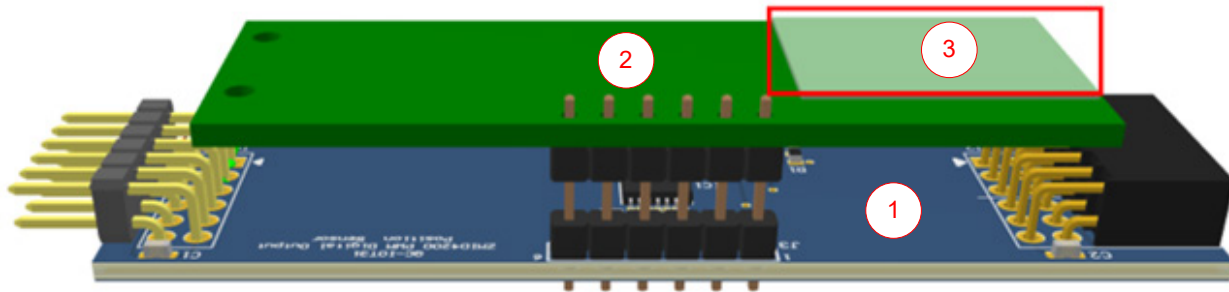

Figure 5. QC-IOT31 Hardware Setup with Linear Coil

## 2.4 Kit Hardware Connections

To setup the evaluation kit, see [Figure 6](#) and use the following procedures:

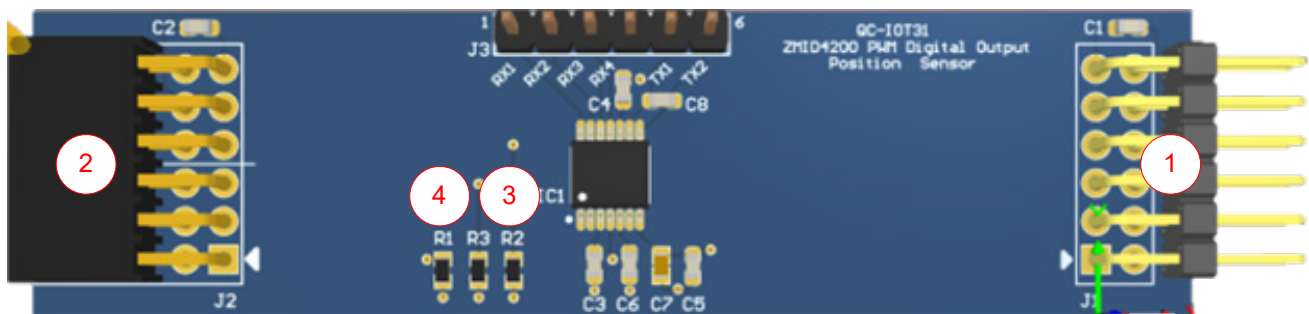

Figure 6. Evaluation Kit Connections

Number	Function
1	Connect to Board
2	Other Pmod connects here
3	I <sup>2</sup> C pull-up resistors (R2 and R3)
4	IRQ pull-up resistor (R1)

1. Ensure the MCU evaluation kit being used has a Pmod connector set to Type 6A (refer to the kit hardware manual to confirm).
  - a. If no Type 6A Pmod is available, ensure the MCU evaluation kit can use the Pmod interposer board and insert the board into the MCU connector before adding any sensor boards.
2. Plug in the QC-IOT31-ZMID4200POCZ to the Type 6A connector, taking care to align Pin 1 on the sensor board and MCU kit.
3. Connect the J3, J4 and J5 jumpers to place 1kΩ pull-up resistors on the IRQ and I<sup>2</sup>C bus lines.
  - a. Only one set of pull-up resistors should be used on the I<sup>2</sup>C bus lines. If multiple sensor boards are used, only one board should have the jumpers present.

- b. MCU kits typically do not have pull-up resistors present on these lines. Ensure to check for them.
- 4. The sensor is now ready to be used in the system. Follow the MCU kit instructions for connecting and powering up the evaluation kit.

### 3. Programming Interface

Programming of the system is accomplished through the Renesas IDE, [e2 studio](#). See the MCU evaluation kit documentation to set up the initial project in e2 studio. As the project is initialized, adding the ZMID4200 sensor to the project only takes a few steps.

#### 1. Project settings, configuration, and source code building:

IDE environment used for code development is e2-studio. [Figure 7](#) shows the steps to debug the board for the first time.

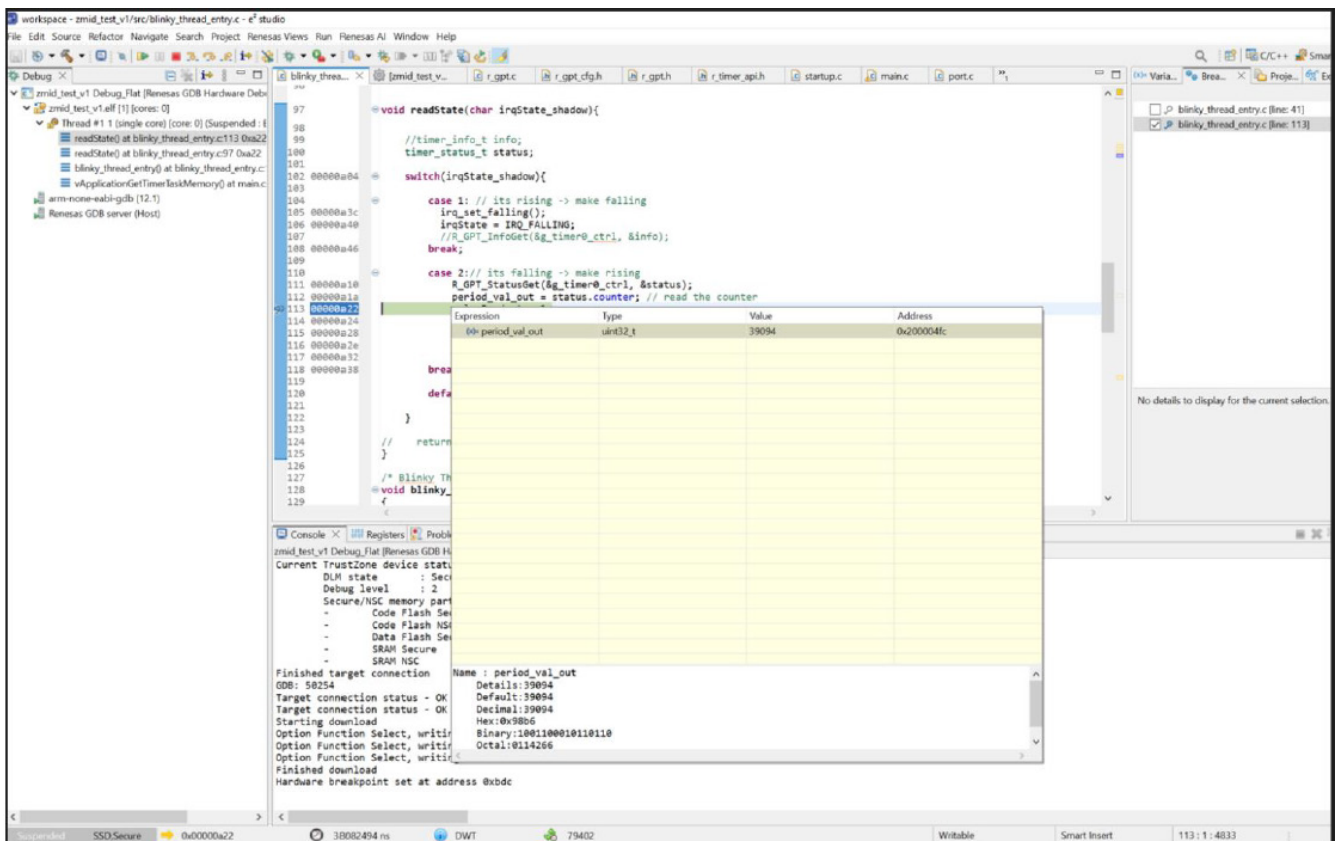

Figure 7. Debugging the Board

## 4. Board Design

### 4.1 Schematic Diagram

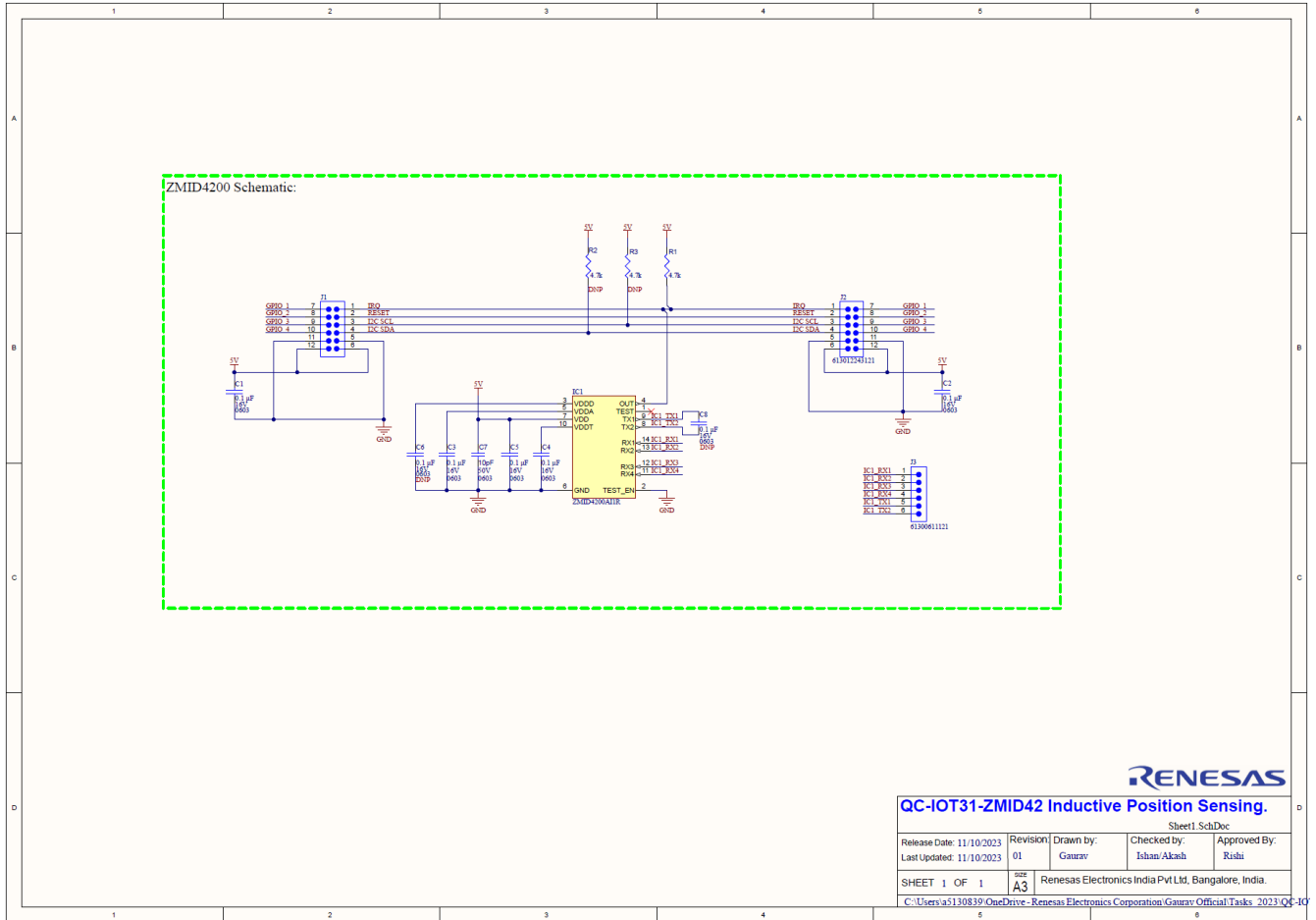

Figure 8. Application Schematic Diagram

### 4.2 Bill of Materials (BOM)

#### 4.2.1 Pmod Base Board BOM

Qty	Reference Designator	Description	Assembly Note	Manufacturer	Manufacturer Part Number
5	C1, C2, C3, C4, C5	0.1µF ±10% 16V Ceramic Capacitor X7R 0603	Fitted	Würth Elektronik	885012206046
2	C6, C8	0.1µF ±10% 16V Ceramic Capacitor X7R 0603	Not Fitted	Würth Elektronik	885012206046
1	C7	Ceramic Capacitor, 10 pF, ±5%, 50V, 0603 (1608 Metric)	Fitted	Renesas	GRM1885C1H100JA01D
1	IC1	Renesas Inductive Position Sensor IC, Analog Output 14pin TSSOP	Fitted	Würth Elektronik	ZMID4200A1R
1	J1	Connector Header Through Hole, Right Angle 12 Position 0.100" (2.54mm)	Fitted	Würth Elektronik	61301221021



Qty	Reference Designator	Description	Assembly Note	Manufacturer	Manufacturer Part Number
1	J2	12 Position Receptacle Connector 0.100" (2.54mm) Through Hole, Right Angle Gold	Fitted	Samtec Inc.	613012243121
1	J3	Connector Header Through Hole 6 Position 0.100" (2.54mm)	Fitted	Harwin Inc.	61300611121
1	R1	4.7kOhms ±1% 0.1W, 1/10W Chip Resistor 0603 (1608 Metric) Moisture Resistant Thick Film	Fitted	YAGEO	RC0603FR-134K7L
2	R2, R3	4.7kOhms ±1% 0.1W, 1/10W Chip Resistor 0603 (1608 Metric) Moisture Resistant Thick Film	Not Fitted	Yageo	RC0603FR-134K7L

#### 4.2.2 Coil Daughter Card Board BOM

Qty	Reference Designator	Description	Assembly Note	Manufacturer	Manufacturer Part Number
1	J3	6 Position Receptacle Connector 0.100" (2.54mm) Through Hole Gold	Fitted	Würth Elektronik	61300611821

### 4.3 Board Layout

#### 4.3.1 Pmod Base Board Layout

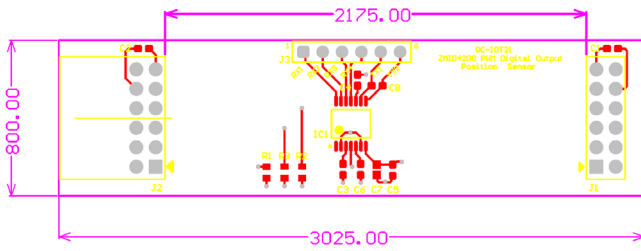

Figure 9. Top Layer

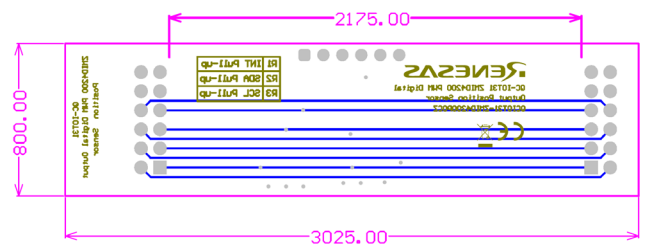

Figure 10. Bottom Layer

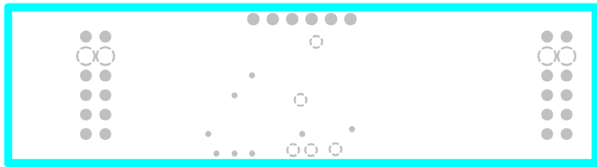

Figure 11. Internal Plane-1 (GND)

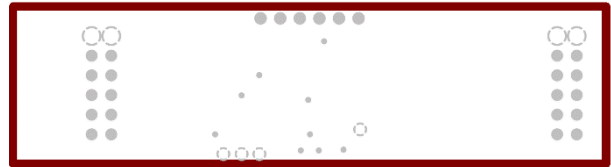

Figure 12. Internal Plane-2 (PWR)

#### 4.3.2 Coil Daughter Card Board Layout

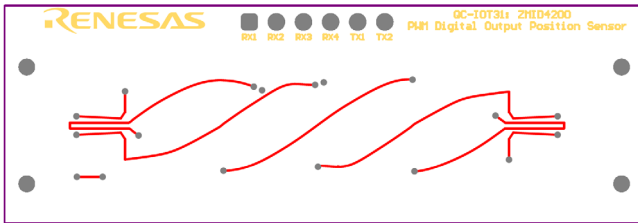

Figure 13. Top Layer

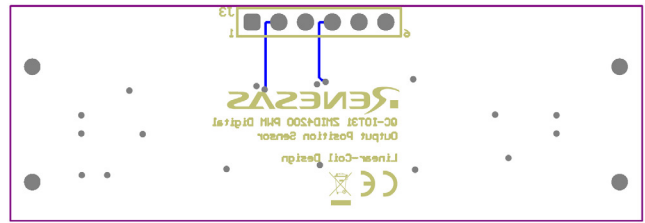

Figure 14. Bottom Layer

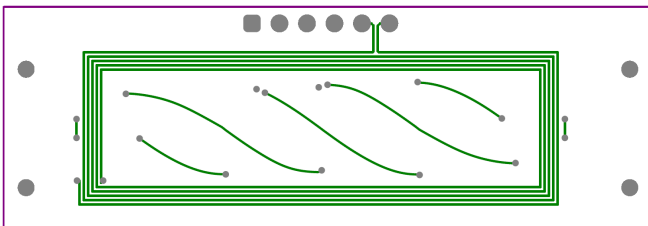

Figure 15. Internal Plane-1

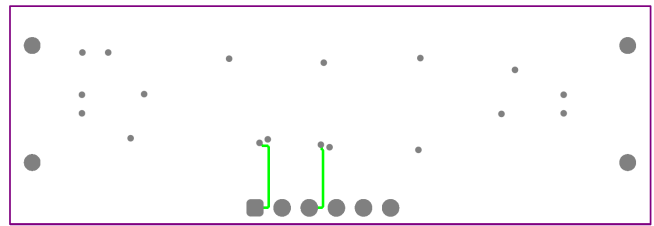

Figure 16. Internal Plane-2 (PWR)

### 4.3.3 Metal Contact Board Layout

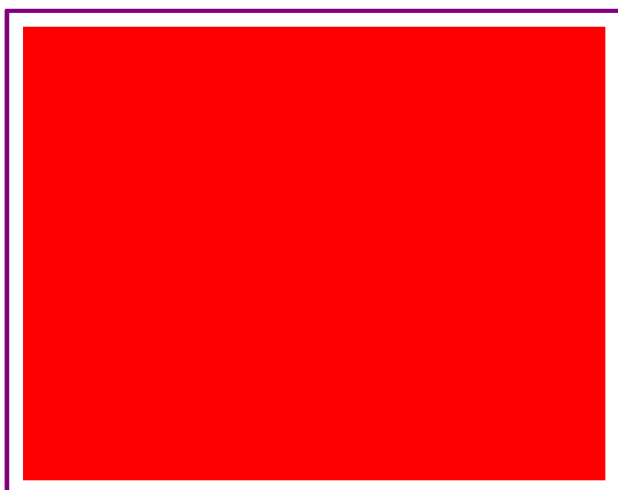

Figure 17. Top Layer



Figure 18. Bottom Layer

## 5. Ordering Information

Orderable Part Number	Description
QCIOT31-ZMID4200POCZ	ZMID4200 PWM-to-Digital Output Sensor
US082-INTERPEVZ	Pmod™ interposer board to convert Type 2A and 3A to Type 6A on older Renesas MCU kits

## 6. Revision History

Revision	Date	Description
1.00	Oct 24, 2024	Initial release.

## IMPORTANT NOTICE AND DISCLAIMER

RENESAS ELECTRONICS CORPORATION AND ITS SUBSIDIARIES (“RENESAS”) PROVIDES TECHNICAL SPECIFICATIONS AND RELIABILITY DATA (INCLUDING DATASHEETS), DESIGN RESOURCES (INCLUDING REFERENCE DESIGNS), APPLICATION OR OTHER DESIGN ADVICE, WEB TOOLS, SAFETY INFORMATION, AND OTHER RESOURCES “AS IS” AND WITH ALL FAULTS, AND DISCLAIMS ALL WARRANTIES, EXPRESS OR IMPLIED, INCLUDING, WITHOUT LIMITATION, ANY IMPLIED WARRANTIES OF MERCHANTABILITY, FITNESS FOR A PARTICULAR PURPOSE, OR NON-INFRINGEMENT OF THIRD-PARTY INTELLECTUAL PROPERTY RIGHTS.

These resources are intended for developers who are designing with Renesas products. You are solely responsible for (1) selecting the appropriate products for your application, (2) designing, validating, and testing your application, and (3) ensuring your application meets applicable standards, and any other safety, security, or other requirements. These resources are subject to change without notice. Renesas grants you permission to use these resources only to develop an application that uses Renesas products. Other reproduction or use of these resources is strictly prohibited. No license is granted to any other Renesas intellectual property or to any third-party intellectual property. Renesas disclaims responsibility for, and you will fully indemnify Renesas and its representatives against, any claims, damages, costs, losses, or liabilities arising from your use of these resources. Renesas' products are provided only subject to Renesas' Terms and Conditions of Sale or other applicable terms agreed to in writing. No use of any Renesas resources expands or otherwise alters any applicable warranties or warranty disclaimers for these products.

(Disclaimer Rev.1.01 Jan 2024)

### Corporate Headquarters

TOYOSU FORESIA, 3-2-24 Toyosu,  
Koto-ku, Tokyo 135-0061, Japan  
[www.renesas.com](http://www.renesas.com)

### Trademarks

Renesas and the Renesas logo are trademarks of Renesas Electronics Corporation. All trademarks and registered trademarks are the property of their respective owners.

### Contact Information

For further information on a product, technology, the most up-to-date version of a document, or your nearest sales office, please visit [www.renesas.com/contact-us/](http://www.renesas.com/contact-us/).