

QCIOT4-DA16600POCZ

Combo Wireless PMOD™ Module Evaluation Board

The QCIOT4-DA16600POCZ is a combo wireless PMOD™ module having Wi-Fi and Bluetooth® Low Energy (BLE) connectivity. The QC-IOT4 PMOD module is designed based on highly integrated ultra-low-power Wi-Fi + Bluetooth Low Energy using a DA16600 combo module solution. Two PMOD connectors are available for Wi-Fi and BLE communication with SPI and UART interfaces, respectively. All of the PMOD signals are also made available when the QC-IOT4 module is interfaced with an Arduino shield connector.

**Board Contents**

- QCIOT4-DA16600POCZ Evaluation Board

**Features**

- Support both RTOS and Linux operating systems:
  - Linux: SPI→Wi-Fi, UART→BLE
  - RTOS (optional): SPI→Wi-Fi/BLE, UART→Wi-Fi/BLE Low power single-band Wi-Fi and BLE communication
- Low power single-band Wi-Fi and BLE
- 3.3V power operated
- 4-layer PCB
- Applications include (but not limited to) IIoT, Gateways
- Standardized type 2A/3A PMOD™ connector supports SPI/UART extended interface
- Standard Arduino connector supports SPI and UART
- Dual connectors allow pass-through signals for daisy-chained solutions in RTOS system mode

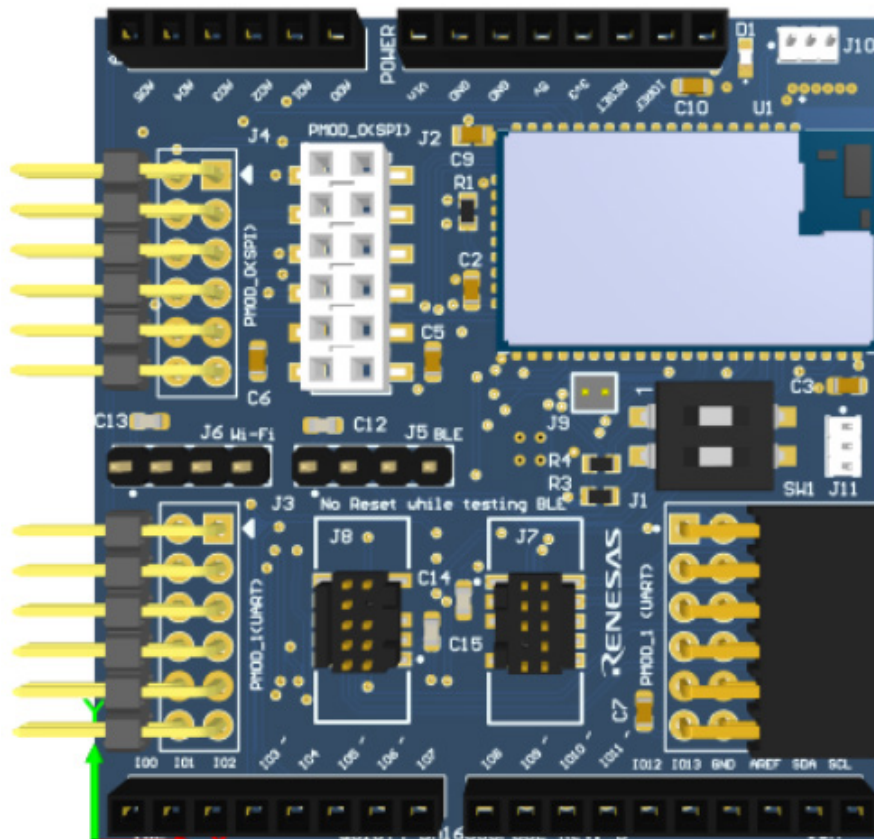

Figure 1. QCIOT4-DA16600POCZ PMOD Evaluation Board (top)

## Contents

<b>1. Functional Description</b>	<b>3</b>
<b>2. Setup</b>	<b>3</b>
2.1 Required Equipment	3
2.2 Software Tools and Versions	3
2.2.1 MPU Platform	3
2.2.2 MCU Platform	4
2.3 On-board Switches	4
2.4 Evaluation Kit Hardware Connections	5
2.4.1 MPU Platform	5
2.4.2 MCU Platform	5
2.4.3 Standalone Wi-Fi or BLE Mode for RF Test Setup	6
<b>3. Application Schematic</b>	<b>7</b>
<b>4. Bill-of-Materials (BOM)</b>	<b>8</b>
<b>5. Board Layout</b>	<b>9</b>
<b>6. Ordering Information</b>	<b>12</b>
<b>7. Revision History</b>	<b>12</b>

## Figures

Figure 1. QCIOT4-DA16600POCZ PMOD Evaluation Board (top)	1
Figure 2. Evaluation Kit Connections with RZ/G2L	5
Figure 3. Evaluation Kit Connections with RA6M4 EVK	6
Figure 4. QCIOT4-DA16600POCZ Application Schematic	7
Figure 5. Silkscreen Top	9
Figure 6. Copper Top	10
Figure 7. Copper L1 Plane (GND)	10
Figure 8. Copper L2 Plane (PWR)	11
Figure 9. Copper Bottom	11
Figure 10. Silkscreen Bottom	12

## Tables

Table 1. Renesas MPU and MCU Evaluation Kits Capable of Supporting Type 2A/3A PMOD/Arduino Connector Using the QCIOT4-DA16600POCZ	3
Table 2. Truth Table for On-board Switches	4
Table 3. QC-IOT4 Evaluation Board Bill-of-Materials	8

# 1. Functional Description

The QC-IOT4 PMOD is a Wi-Fi/BLE-enabled module for any SPI/UART MPU/MCUs. The module can connect to an MCU board through Arduino shield or to an RZ family/MPU carrier board through PMOD. The QC-IOT4 uses the DA16600MOD Wi-Fi/BLE module, providing ultra-low power Wi-Fi IEEE802.11b/g/n, 1x1, 20MHz channel bandwidth 2.4GHz, and Bluetooth v5.1.

## 2. Setup

### 2.1 Required Equipment

The following additional lab equipment (sold separately) is required for using the board:

- Any MPU board that supports both Type 2A and 3A PMOD
- Any MCU board that supports Arduino connection (see Table 1)

**Table 1. Renesas MPU and MCU Evaluation Kits Capable of Supporting Type 2A/3A PMOD/Arduino Connector Using the QC-IOT4-DA16600POCZ**

RZ	RA	RL78
EK-RZ/G2L	EK-RA4W1	RL78/G23-FPB
EK-RZ/V2L	EK-RA2A1	RL78/G22-FPB
EK-RZ/G2UL	EK-RA4M1	RL78/G14-FPB
EK-RZ/A3UL	EK-RA6M1	RL78/G15-FPB
EK-RZ/Five	EK-RA6M2	-
-	EK-RA6M3	-
-	EK-RA6M3G	-

*Note:* The table above is not a comprehensive list of supporting MPU and MCU Kits. See the respective evaluation kit hardware manual to confirm PMOD/Arduino pinout.

### 2.2 Software Tools and Versions

#### 2.2.1 MPU Platform

1. For Host details and RZ BSP versions, refer to the *Operating Environment* section in the software manual.
2. Port the DA16600 Linux driver to RZ/G2L Kernel 5.10 latest BSP.
3. Add the Linux driver to the RZ family BSP to support all RZ devices (RZ/G2L tested only).
4. Connect to the board following the hardware connection section (see Figure 2).
5. Visit Renesas [Quick-Connect IoT Platform](#) for more information about creating your customized system solution.

**Important:** Do not use the reset button (blue button) while BLE testing.

*Note:* The RZ/G2L is currently the only solution available. Other MPU software is in development.

### 2.2.2 MCU Platform

1. Download AT CMD binary from the webpage.
2. Flash the binary to the QC-IOT4 board.
3. Reflash MCU software.
4. Connect the QC-IOT4 board to the MCU board (see Figure 3).

*Note:* Refer to the “QC-IOT4 DA16600 AT-CMD Test Manual” for detailed descriptions of how to flash:

- AT-CMD (SPI and UART) binary in DA16600
- Firmware in RA6M4 MCU for AT-CMD test

### 2.3 On-board Switches

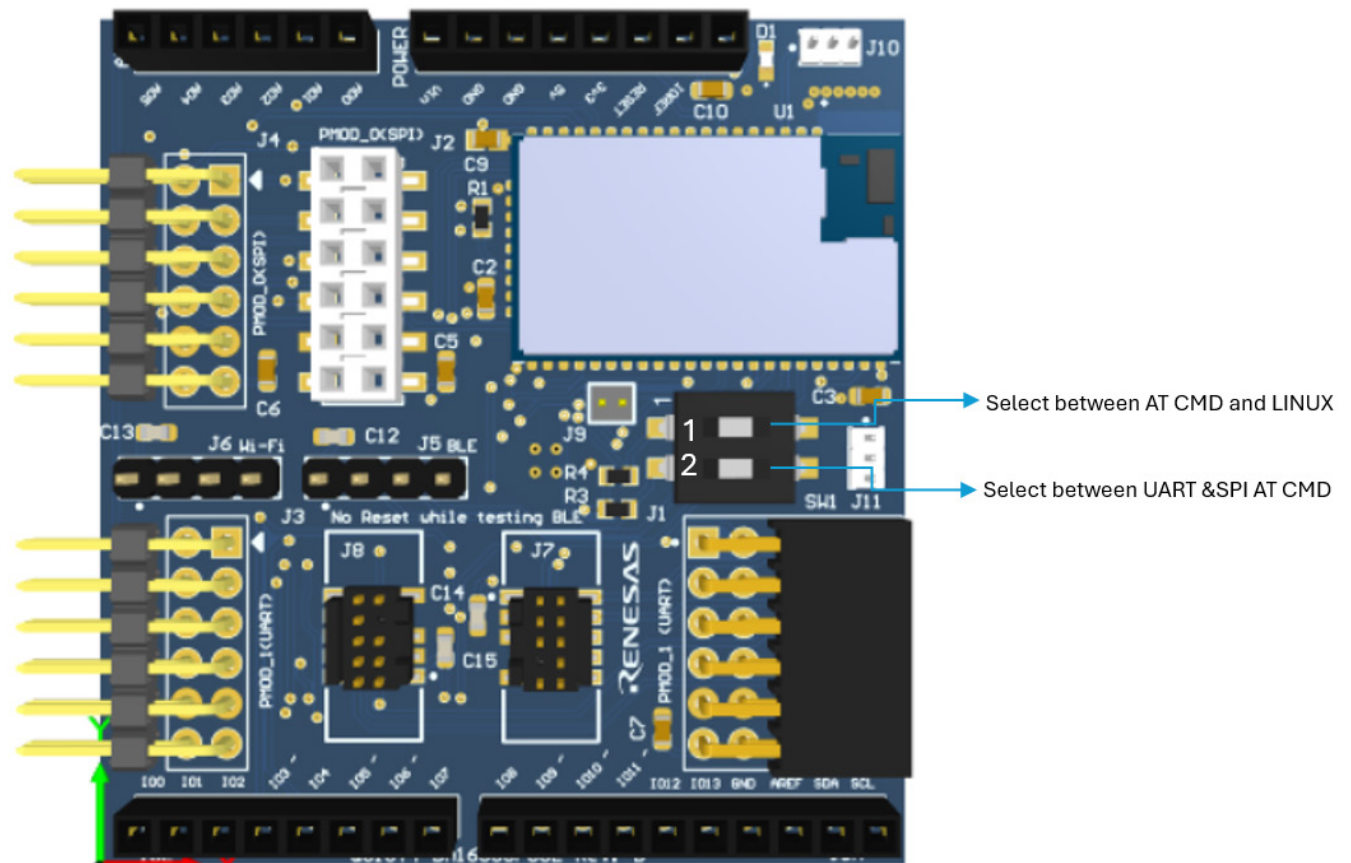

Table 2. Truth Table for On-board Switches

SW1	SW2	Function
0	0	UART AT CMD
0	1	SPI AT CMD
1	x	Linux

*Note:* The “ON” label written on the switch means that the switch is closed and the line is pulled to ground. GP will read it as a logic 0 or Low. Vice versa for the other switch positions.

## 2.4 Evaluation Kit Hardware Connections

### 2.4.1 MPU Platform

Use the following procedures to set up the kit connections with RZ/G2L SMARC EVK as shown in Figure 2.

1. Connect QCOT4-DA1660POCZ module to PMOD connector of RZ/G2L SMARC EVK platform.
2. Connect the micro-SD Card to the slot present in the carrier board connection (see Figure 2).
3. Connect debug console to the serial terminal application software (see Figure 2)
4. Wi-Fi router that connects wirelessly to QCOT4-DA1660POCZ module.
5. Wi-Fi router that connects wired/wireless to desktop/laptop.
6. Before powering up the board, check the switch settings on the QCOT4-DA1660POCZ board. For Linux, SW1 should be 1, irrespective of the position of SW2 (for detailed information, see section 3.3).
7. Power on SMARC EVK using a type C USB cable.

**Important:** No other Arduino shield on the top of QCOT4-DA1660POCZ board is recommended.

**Note:** PMOD female connectors are redundant (not available for use).

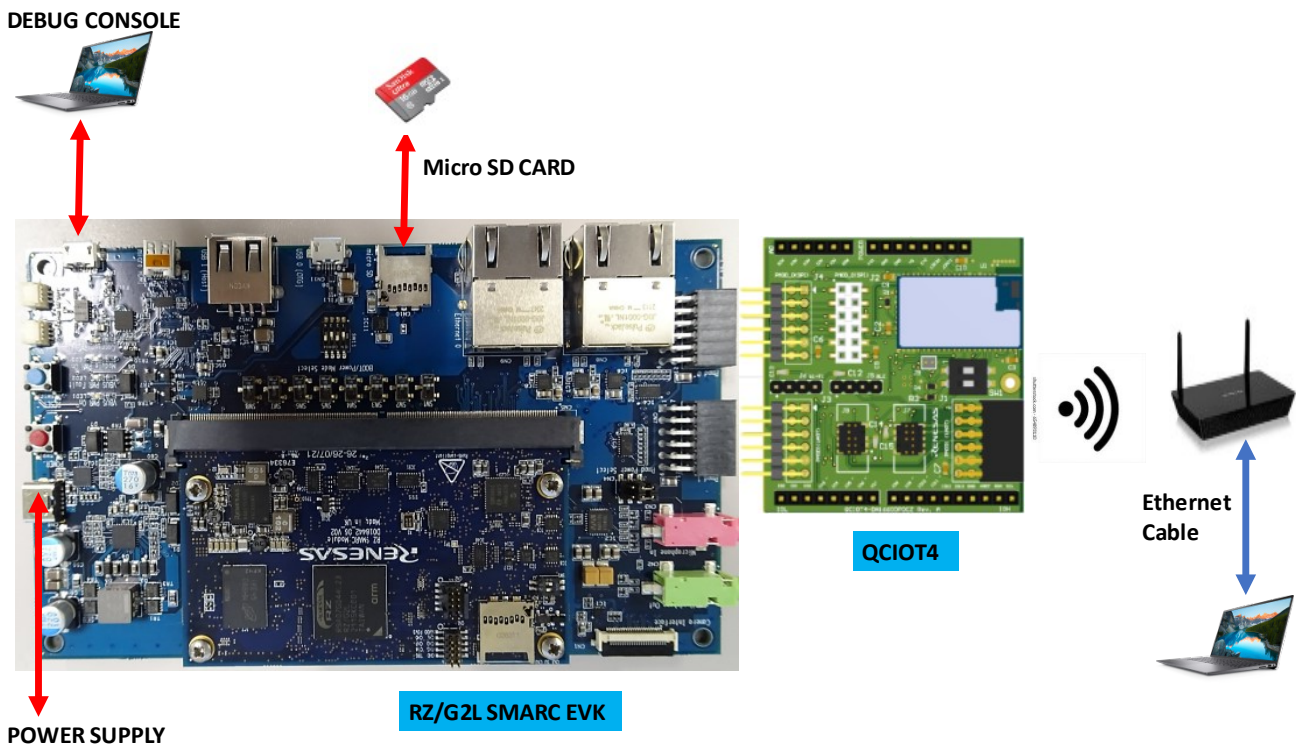

Figure 2. Evaluation Kit Connections with RZ/G2L

### 2.4.2 MCU Platform

Use the following procedures to set up the kit connections with RA6M4 EVK as shown in Figure 3.

1. The QCOT4-DA1660POCZ board can be interfaced with RA6M4 MCU EVK with Arduino connector provision.
2. Connect the QCOT4-DA1660POCZ board with MCU as shown in Figure 3.
3. Before powering up the board check the switch settings on QCOT4-DA1660POCZ board (for detailed information, see section 3.3).
4. Connect the USB debug port of RA6M4 to the PC as shown in Figure 3.

**Important:** No other Arduino shield on the top of QC\_IOT4-DA1660POCZ board is recommended.

**Note:** If SPI is in use for Wi-Fi/BLE communication, the UART PMOD (PMOD1) is available, and vice versa.

**Note:** Jumper option J10 is available to switch between Wi-Fi and BLE (without jumper the kit is in Wi-Fi mode; with jumper it is in BLE mode). Then using the serial interface, select the channels for Wi-Fi (IO0 and IO1 of Arduino connector) and BLE (pin 1 of J3 and J1).

**Note:** Jumper option J11 is available for BLE reset which is required while flashing the BLE firmware to the board using the Renesas [SmartBond™ Development Tools](#).

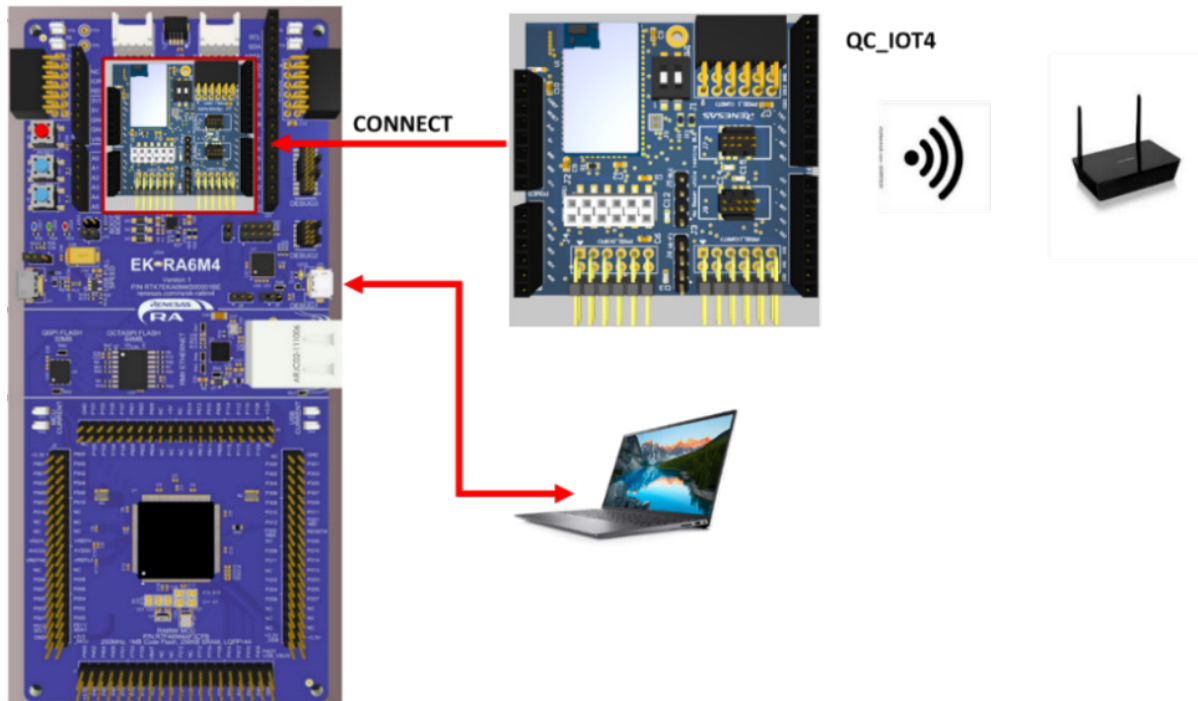

Figure 3. Evaluation Kit Connections with RA6M4 EVK

### 2.4.3 Standalone Wi-Fi or BLE Mode for RF Test Setup

Use the following procedures to setup the kit connections that enable the standalone QC-IOT4 board to work either in Wi-Fi or BLE mode.

#### Wi-Fi Mode

1. By default, the device is in Wi-Fi Mode without jumper on J10.
2. Select the wi-fi channel using serial.
3. With the USB to Serial converter, use pins IO0 and IO1 of the Arduino connector to assess the serial.
4. Channel selection can now be performed using the DA16200\_DA16600\_AT\_GUI Tool.

#### BLE Mode

1. Short the jumper on J10 to place the device in BLE mode.
2. Download the firmware for BLE (GUI ask for BLE Reset). This is accomplished by shorting the jumper setting J11 for 1 to 2 seconds.
3. Using the USB to Serial converter, connect Pin\_1 of J1 and J3. Then using the [SmartBond™ Development Tools](#), perform channel selection for BLE.

**Note:** The entirety of the above procedures are performed only when compliance testing is required.

### 3. Application Schematic

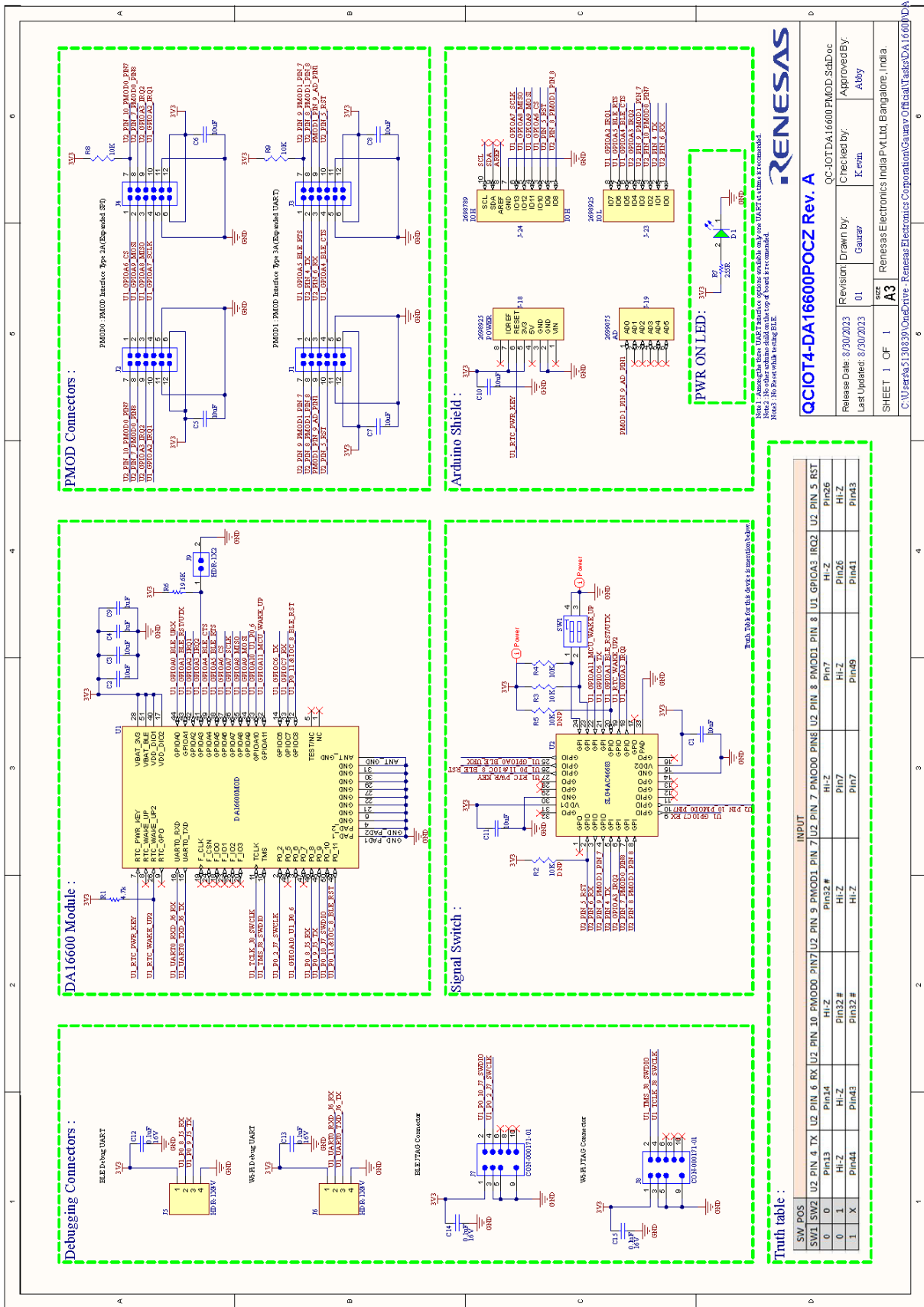

Figure 4. QC-IOT4-DA16600POCZ Application Schematic

## 4. Bill-of-Materials (BOM)

Table 3. QC-IOT4 Evaluation Board Bill-of-Materials

Item	Qty	Reference	Description	Value	PCB Footprint	Part Number
1	1	AD	6 Position Receptacle Connector 0.100" (2.54mm) Through Hole Gold	-	TH (P-2.54mm)	SSQ-106-03-G-S
2	9	C1, C2, C3, C5, C6, C7, C8, C10, C11	10µF ±10% 16V Ceramic Capacitor X5R 0603 (1608 Metric)	10µF	0603	885012106031
3	2	C4, C9	Chip Capacitor, 1µF, ±10%, 16V, 0603 (1608 Metric)	1µF	0603	885012206052
4	4	C12, C13, C14, C15	0.1µF ±10% 16V Ceramic Capacitor X7R 0603 (1608 Metric)	0.1µF	0603	885012206046
5	1	D1	WL-SMCD Mono-color Chip LED Diffused, SMT, size 0603, Bright Green, 2V, 140°	-	0603	150060VS55040
6	1	IOH	10 Position Receptacle Connector 0.100" (2.54mm) Through Hole Gold	-	TH (P-2.54mm)	SSQ-110-03-G-S
7	2	IOL, Power	8 Position Receptacle Connector 0.100" (2.54mm) Through Hole Gold	-	TH (P-2.54mm)	SSQ-108-03-G-S
8	1	J1	12 Position Receptacle Connector 0.100" (2.54mm) Through Hole, Right Angle Gold	-	TH (P-2.54 × 2.54mm)	613012243121
9	1	J2	CONN Socket 12POS 2ROW Vertical SMT	-	SMD (P-2.54 × 2.54mm)	61001221821
10	2	J3, J4	Connector Header Through Hole, Right Angle 12-Position 0.100" (2.54mm)	-	TH (P-2.54 × 2.54mm)	61301221021
11	2	J5, J6	Header, 1 × 4, 0.1"	-	TH (P-2.54mm)	61300411121
12	2	J7, J8	10-Position Shrouded Header 1.27mm Pitch Pin #7 Removed	-	SMD (P-1.27 × 1.27mm)	FTSH-105-01-L-DV-007-K
13	1	J9	CONN Header VERT 2POS 1.27mm	-	TH (P-1.27mm)	FTS-102-01-L-S
14	2	J10, J11	Male Header, Pitch 1.27mm, 1 position, Height 4mm, Tail Length 2.3mm, -40 to 105°, RoHS, Bulk	-	TH (P-1.27mm)	GRPB031VWVNR
15	1	R1	Chip Resistor, 4.7kOhms, ±1%, 0.1 W, -55 to 155 °C, 0603 (1608 Metric)	4.7kOhm	0603	RC0603FR-134K7L
16	0	R2, R5, R8, R9	Chip Resistor, 10kOhms, ±1%, 01 W, -55 to 155 °C, 0603 (1608 Metric)	10kOhm	0603	RC0603FR-0710KL
17	2	R3, R4	Chip Resistor, 10kOhms, ±1%, 01 W, -55 to 155 °C, 0603 (1608 Metric)	10kOhm	0603	RC0603FR-0710KL
18	1	R6	19.6kOhms ±1% 0.1W, 1/10W Chip Resistor 0603 (1608 Metric)	19.6kOhms	0603	RC0603FR-0719K6L



Item	Qty	Reference	Description	Value	PCB Footprint	Part Number
19	1	R7	255 Ohms ±1% 0.1W, 1/10W Chip Resistor 0603 (1608 Metric) Moisture Resistant Thick Film	255 Ohms	0603	RC0603FR-07255RL
20	1	SW1	DIP Switch, 2-Position, SPST	-	2.54 × 6.02 × 4.40 (PxLxH)	418121270802
21	1	U1	DA16600MOD, Wi-Fi, 802.11b/g/n, Bluetooth LE, Combo Module, SM	-	14.3 × 24.3 × 3.0	DA16600MOD-AAC4WA32
22	1	U2	GreenPAK Programmable Mixed-signal Matrix with Asynchronous State Machine and Dual Supply	-	TQFN-32	SLG4AC46683
23	3	Short Jumper	2 (1 × 2) Position Shunt Connector Black Closed Top, Grip 0.050" (1.27mm) Gold	-	-	M50-2000005

## 5. Board Layout

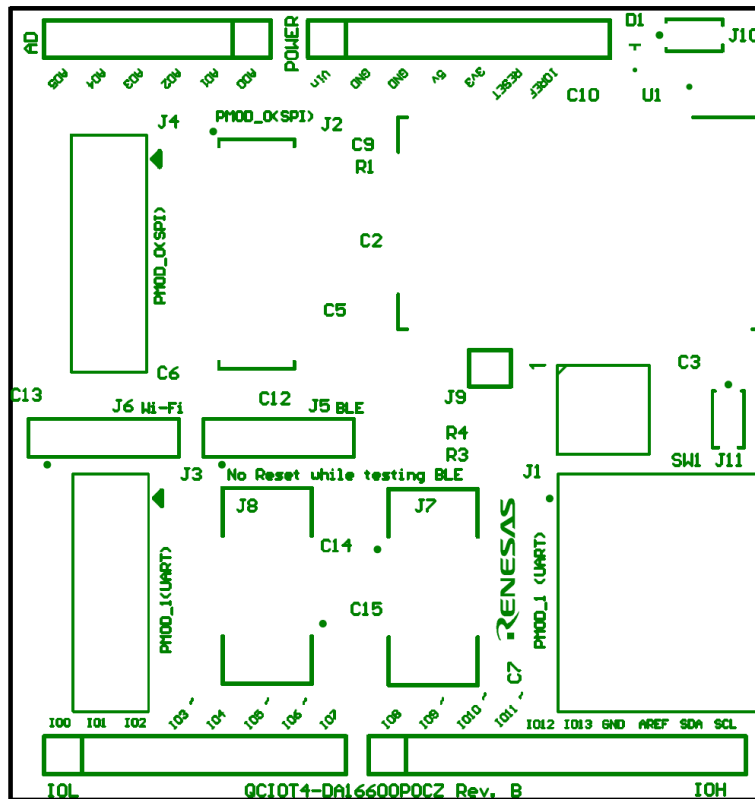

Figure 5. Silkscreen Top

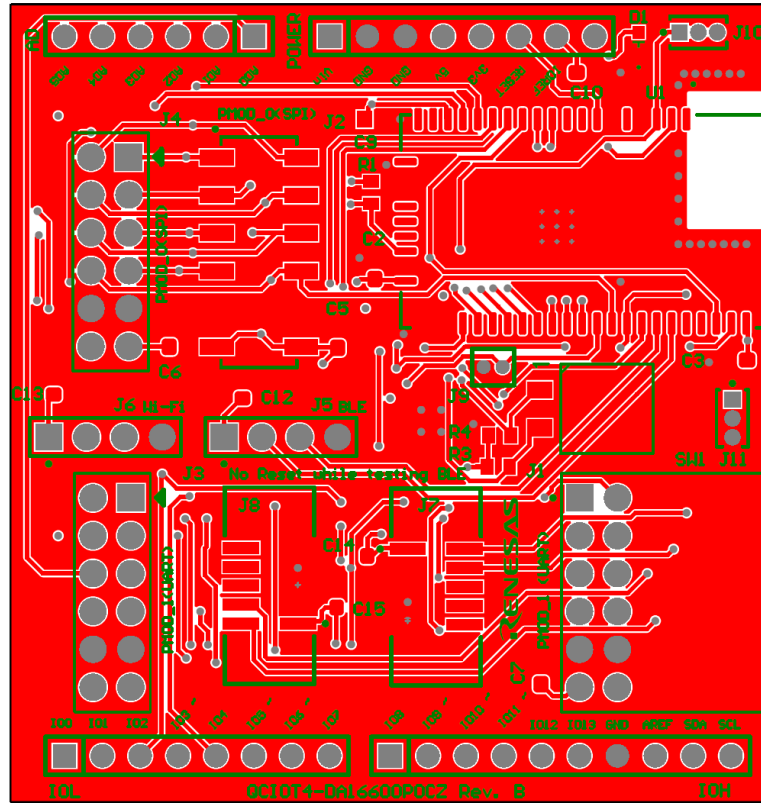

Figure 6. Copper Top

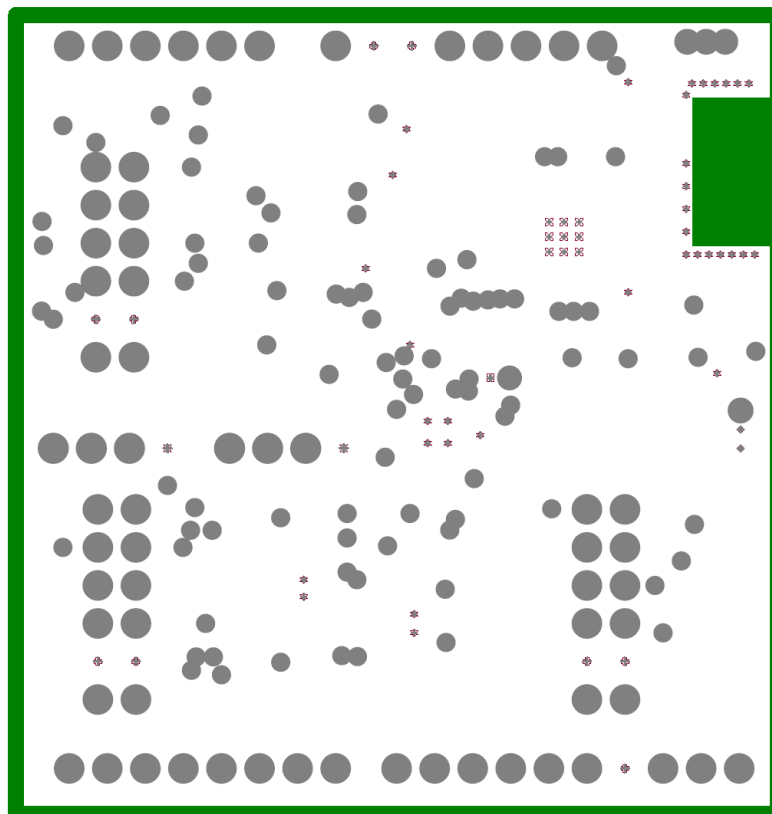

Figure 7. Copper L1 Plane (GND)

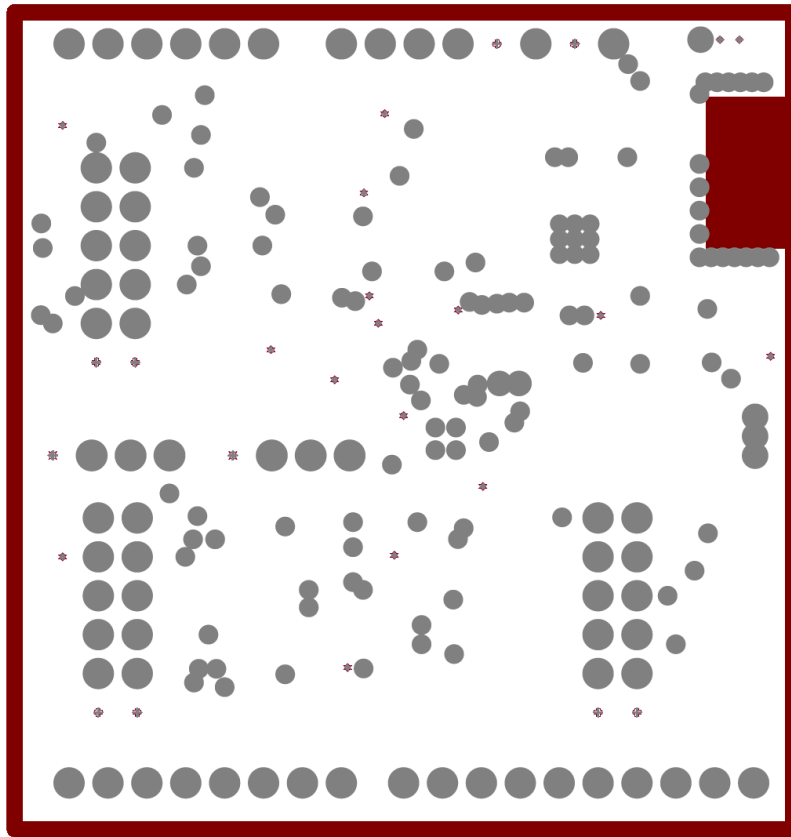

Figure 8. Copper L2 Plane (PWR)

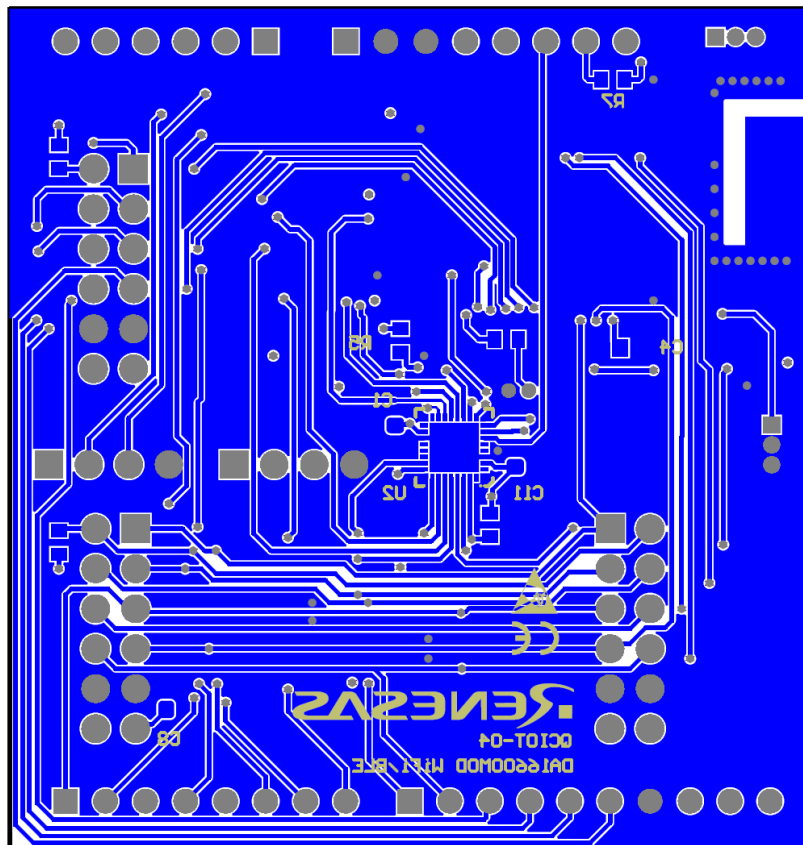

Figure 9. Copper Bottom

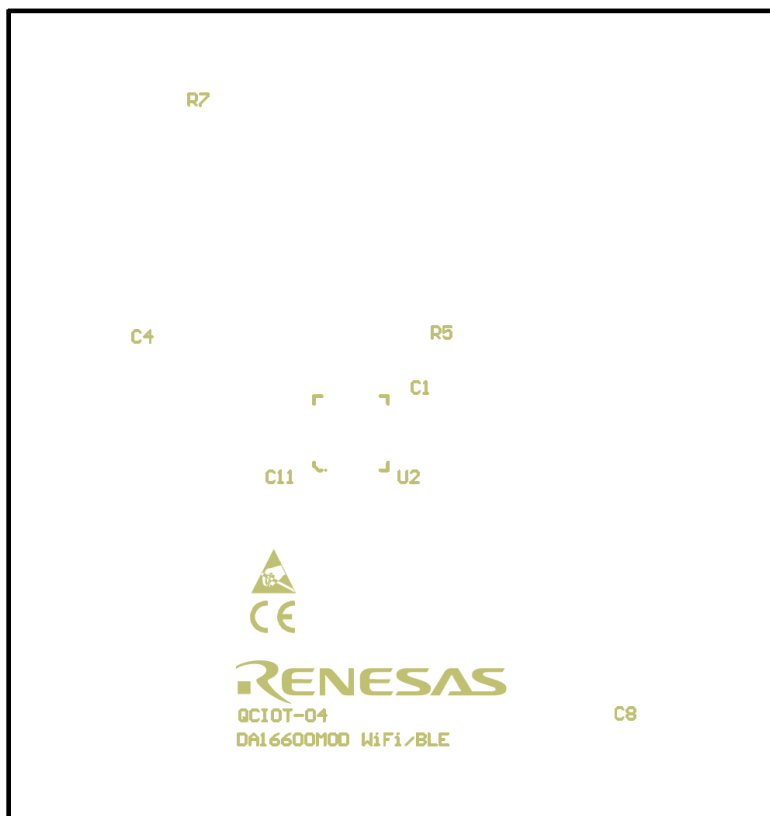

Figure 10. Silkscreen Bottom

## 6. Ordering Information

Part Number	Description
QCIOT4-DA16600POCZ	QCIOT04-DA16600POCZ PMOD™ Evaluation Board

## 7. Revision History

Revision	Date	Description
1.01	Sep 6, 2024	<ul style="list-style-type: none"> <li>▪ Updated Figure 1, Figure 5, Figure 6, Figure 7, Figure 8, Figure 9, and Figure 10.</li> <li>▪ Updated items 7 and 14 and added item 23 in Table 3.</li> <li>▪ Updated image in section 2.3.</li> <li>▪ Added notes to section 2.4.2.</li> <li>▪ Added section 2.4.3.</li> </ul>
1.00	Sep 13, 2023	Initial release.

## IMPORTANT NOTICE AND DISCLAIMER

RENESAS ELECTRONICS CORPORATION AND ITS SUBSIDIARIES (“RENESAS”) PROVIDES TECHNICAL SPECIFICATIONS AND RELIABILITY DATA (INCLUDING DATASHEETS), DESIGN RESOURCES (INCLUDING REFERENCE DESIGNS), APPLICATION OR OTHER DESIGN ADVICE, WEB TOOLS, SAFETY INFORMATION, AND OTHER RESOURCES “AS IS” AND WITH ALL FAULTS, AND DISCLAIMS ALL WARRANTIES, EXPRESS OR IMPLIED, INCLUDING, WITHOUT LIMITATION, ANY IMPLIED WARRANTIES OF MERCHANTABILITY, FITNESS FOR A PARTICULAR PURPOSE, OR NON-INFRINGEMENT OF THIRD-PARTY INTELLECTUAL PROPERTY RIGHTS.

These resources are intended for developers who are designing with Renesas products. You are solely responsible for (1) selecting the appropriate products for your application, (2) designing, validating, and testing your application, and (3) ensuring your application meets applicable standards, and any other safety, security, or other requirements. These resources are subject to change without notice. Renesas grants you permission to use these resources only to develop an application that uses Renesas products. Other reproduction or use of these resources is strictly prohibited. No license is granted to any other Renesas intellectual property or to any third-party intellectual property. Renesas disclaims responsibility for, and you will fully indemnify Renesas and its representatives against, any claims, damages, costs, losses, or liabilities arising from your use of these resources. Renesas' products are provided only subject to Renesas' Terms and Conditions of Sale or other applicable terms agreed to in writing. No use of any Renesas resources expands or otherwise alters any applicable warranties or warranty disclaimers for these products.

(Disclaimer Rev.1.01 Jan 2024)

### Corporate Headquarters

TOYOSU FORESIA, 3-2-24 Toyosu,  
Koto-ku, Tokyo 135-0061, Japan  
[www.renesas.com](http://www.renesas.com)

### Trademarks

Renesas and the Renesas logo are trademarks of Renesas Electronics Corporation. All trademarks and registered trademarks are the property of their respective owners.

### Contact Information

For further information on a product, technology, the most up-to-date version of a document, or your nearest sales office, please visit [www.renesas.com/contact-us/](http://www.renesas.com/contact-us/).