

# RL78/G1D Module (RY7011)

User's Manual: Hardware

Renesas Bluetooth low energy Module

All information contained in these materials, including products and product specifications, represents information on the product at the time of publication and is subject to change by Renesas Electronics Corp. without notice. Please review the latest information published by Renesas Electronics Corp. through various means, including the Renesas Electronics Corp. website (<http://www.renesas.com>).

## Notice

1. Descriptions of circuits, software and other related information in this document are provided only to illustrate the operation of semiconductor products and application examples. You are fully responsible for the incorporation or any other use of the circuits, software, and information in the design of your product or system. Renesas Electronics disclaims any and all liability for any losses and damages incurred by you or third parties arising from the use of these circuits, software, or information.
2. Renesas Electronics hereby expressly disclaims any warranties against and liability for infringement or any other claims involving patents, copyrights, or other intellectual property rights of third parties, by or arising from the use of Renesas Electronics products or technical information described in this document, including but not limited to, the product data, drawings, charts, programs, algorithms, and application examples.
3. No license, express, implied or otherwise, is granted hereby under any patents, copyrights or other intellectual property rights of Renesas Electronics or others.
4. You shall be responsible for determining what licenses are required from any third parties, and obtaining such licenses for the lawful import, export, manufacture, sales, utilization, distribution or other disposal of any products incorporating Renesas Electronics products, if required.
5. You shall not alter, modify, copy, or reverse engineer any Renesas Electronics product, whether in whole or in part. Renesas Electronics disclaims any and all liability for any losses or damages incurred by you or third parties arising from such alteration, modification, copying or reverse engineering.
6. Renesas Electronics products are classified according to the following two quality grades: "Standard" and "High Quality". The intended applications for each Renesas Electronics product depends on the product's quality grade, as indicated below.
  - "Standard": Computers; office equipment; communications equipment; test and measurement equipment; audio and visual equipment; home electronic appliances; machine tools; personal electronic equipment; industrial robots; etc.
  - "High Quality": Transportation equipment (automobiles, trains, ships, etc.); traffic control (traffic lights); large-scale communication equipment; key financial terminal systems; safety control equipment; etc.
- Unless expressly designated as a high reliability product or a product for harsh environments in a Renesas Electronics data sheet or other Renesas Electronics document, Renesas Electronics products are not intended or authorized for use in products or systems that may pose a direct threat to human life or bodily injury (artificial life support devices or systems; surgical implantations; etc.), or may cause serious property damage (space system; undersea repeaters; nuclear power control systems; aircraft control systems; key plant systems; military equipment; etc.). Renesas Electronics disclaims any and all liability for any damages or losses incurred by you or any third parties arising from the use of any Renesas Electronics product that is inconsistent with any Renesas Electronics data sheet, user's manual or other Renesas Electronics document.
7. No semiconductor product is absolutely secure. Notwithstanding any security measures or features that may be implemented in Renesas Electronics hardware or software products, Renesas Electronics shall have absolutely no liability arising out of any vulnerability or security breach, including but not limited to any unauthorized access to or use of a Renesas Electronics product or a system that uses a Renesas Electronics product. RENESAS ELECTRONICS DOES NOT WARRANT OR GUARANTEE THAT RENESAS ELECTRONICS PRODUCTS, OR ANY SYSTEMS CREATED USING RENESAS ELECTRONICS PRODUCTS WILL BE INVULNERABLE OR FREE FROM CORRUPTION, ATTACK, VIRUSES, INTERFERENCE, HACKING, DATA LOSS OR THEFT, OR OTHER SECURITY INTRUSION ("Vulnerability Issues"). RENESAS ELECTRONICS DISCLAIMS ANY AND ALL RESPONSIBILITY OR LIABILITY ARISING FROM OR RELATED TO ANY VULNERABILITY ISSUES. FURTHERMORE, TO THE EXTENT PERMITTED BY APPLICABLE LAW, RENESAS ELECTRONICS DISCLAIMS ANY AND ALL WARRANTIES, EXPRESS OR IMPLIED, WITH RESPECT TO THIS DOCUMENT AND ANY RELATED OR ACCOMPANYING SOFTWARE OR HARDWARE, INCLUDING BUT NOT LIMITED TO THE IMPLIED WARRANTIES OF MERCHANTABILITY, OR FITNESS FOR A PARTICULAR PURPOSE.
8. When using Renesas Electronics products, refer to the latest product information (data sheets, user's manuals, application notes, "General Notes for Handling and Using Semiconductor Devices" in the reliability handbook, etc.), and ensure that usage conditions are within the ranges specified by Renesas Electronics with respect to maximum ratings, operating power supply voltage range, heat dissipation characteristics, installation, etc. Renesas Electronics disclaims any and all liability for any malfunctions, failure or accident arising out of the use of Renesas Electronics products outside of such specified ranges.
9. Although Renesas Electronics endeavors to improve the quality and reliability of Renesas Electronics products, semiconductor products have specific characteristics, such as the occurrence of failure at a certain rate and malfunctions under certain use conditions. Unless designated as a high reliability product or a product for harsh environments in a Renesas Electronics data sheet or other Renesas Electronics document, Renesas Electronics products are not subject to radiation resistance design. You are responsible for implementing safety measures to guard against the possibility of bodily injury, injury or damage caused by fire, and/or danger to the public in the event of a failure or malfunction of Renesas Electronics products, such as safety design for hardware and software, including but not limited to redundancy, fire control and malfunction prevention, appropriate treatment for aging degradation or any other appropriate measures. Because the evaluation of microcomputer software alone is very difficult and impractical, you are responsible for evaluating the safety of the final products or systems manufactured by you.
10. Please contact a Renesas Electronics sales office for details as to environmental matters such as the environmental compatibility of each Renesas Electronics product. You are responsible for carefully and sufficiently investigating applicable laws and regulations that regulate the inclusion or use of controlled substances, including without limitation, the EU RoHS Directive, and using Renesas Electronics products in compliance with all these applicable laws and regulations. Renesas Electronics disclaims any and all liability for damages or losses occurring as a result of your noncompliance with applicable laws and regulations.
11. Renesas Electronics products and technologies shall not be used for or incorporated into any products or systems whose manufacture, use, or sale is prohibited under any applicable domestic or foreign laws or regulations. You shall comply with any applicable export control laws and regulations promulgated and administered by the governments of any countries asserting jurisdiction over the parties or transactions.
12. It is the responsibility of the buyer or distributor of Renesas Electronics products, or any other party who distributes, disposes of, or otherwise sells or transfers the product to a third party, to notify such third party in advance of the contents and conditions set forth in this document.
13. This document shall not be reprinted, reproduced or duplicated in any form, in whole or in part, without prior written consent of Renesas Electronics.
14. Please contact a Renesas Electronics sales office if you have any questions regarding the information contained in this document or Renesas Electronics products.

(Note1) "Renesas Electronics" as used in this document means Renesas Electronics Corporation and also includes its directly or indirectly controlled subsidiaries.

(Note2) "Renesas Electronics product(s)" means any product developed or manufactured by or for Renesas Electronics.

(Rev.5.0-1 October 2020)

## Corporate Headquarters

TOYOSU FORESIA, 3-2-24 Toyosu,  
Koto-ku, Tokyo 135-0061, Japan

[www.renesas.com](http://www.renesas.com)

## Contact information

For further information on a product, technology, the most up-to-date version of a document, or your nearest sales office, please visit:

[www.renesas.com/contact/](http://www.renesas.com/contact/).

## Trademarks

Renesas and the Renesas logo are trademarks of Renesas Electronics Corporation. All trademarks and registered trademarks are the property of their respective owners.

## General Precautions in the Handling of Microprocessing Unit and Microcontroller Unit Products

The following usage notes are applicable to all Microprocessing unit and Microcontroller unit products from Renesas. For detailed usage notes on the products covered by this document, refer to the relevant sections of the document as well as any technical updates that have been issued for the products.

### 1. Precaution against Electrostatic Discharge (ESD)

A strong electrical field, when exposed to a CMOS device, can cause destruction of the gate oxide and ultimately degrade the device operation. Steps must be taken to stop the generation of static electricity as much as possible, and quickly dissipate it when it occurs. Environmental control must be adequate. When it is dry, a humidifier should be used. This is recommended to avoid using insulators that can easily build up static electricity. Semiconductor devices must be stored and transported in an anti-static container, static shielding bag or conductive material. All test and measurement tools including work benches and floors must be grounded. The operator must also be grounded using a wrist strap. Semiconductor devices must not be touched with bare hands. Similar precautions must be taken for printed circuit boards with mounted semiconductor devices.

### 2. Processing at power-on

The state of the product is undefined at the time when power is supplied. The states of internal circuits in the LSI are indeterminate and the states of register settings and pins are undefined at the time when power is supplied. In a finished product where the reset signal is applied to the external reset pin, the states of pins are not guaranteed from the time when power is supplied until the reset process is completed. In a similar way, the states of pins in a product that is reset by an on-chip power-on reset function are not guaranteed from the time when power is supplied until the power reaches the level at which resetting is specified.

### 3. Input of signal during power-off state

Do not input signals or an I/O pull-up power supply while the device is powered off. The current injection that results from input of such a signal or I/O pull-up power supply may cause malfunction and the abnormal current that passes in the device at this time may cause degradation of internal elements. Follow the guideline for input signal during power-off state as described in your product documentation.

### 4. Handling of unused pins

Handle unused pins in accordance with the directions given under handling of unused pins in the manual. The input pins of CMOS products are generally in the high-impedance state. In operation with an unused pin in the open-circuit state, extra electromagnetic noise is induced in the vicinity of the LSI, an associated shoot-through current flows internally, and malfunctions occur due to the false recognition of the pin state as an input signal become possible.

### 5. Clock signals

After applying a reset, only release the reset line after the operating clock signal becomes stable. When switching the clock signal during program execution, wait until the target clock signal is stabilized. When the clock signal is generated with an external resonator or from an external oscillator during a reset, ensure that the reset line is only released after full stabilization of the clock signal. Additionally, when switching to a clock signal produced with an external resonator or by an external oscillator while program execution is in progress, wait until the target clock signal is stable.

### 6. Voltage application waveform at input pin

Waveform distortion due to input noise or a reflected wave may cause malfunction. If the input of the CMOS device stays in the area between  $V_{IL}$  (Max.) and  $V_{IH}$  (Min.) due to noise, for example, the device may malfunction. Take care to prevent chattering noise from entering the device when the input level is fixed, and also in the transition period when the input level passes through the area between  $V_{IL}$  (Max.) and  $V_{IH}$  (Min.).

### 7. Prohibition of access to reserved addresses

Access to reserved addresses is prohibited. The reserved addresses are provided for possible future expansion of functions. Do not access these addresses as the correct operation of the LSI is not guaranteed.

### 8. Differences between products

Before changing from one product to another, for example to a product with a different part number, confirm that the change will not lead to problems. The characteristics of a microprocessing unit or microcontroller unit products in the same group but having a different part number might differ in terms of internal memory capacity, layout pattern, and other factors, which can affect the ranges of electrical characteristics, such as characteristic values, operating margins, immunity to noise, and amount of radiated noise. When changing to a product with a different part number, implement a system-evaluation test for the given product.

# How to Use This Manual

**Readers** This manual is intended for user engineers who wish to understand the functions of the RY7011 and design and develop application systems and programs for this module.

**Purpose** This manual is intended to give users an understanding of the functions described in the **Organization** below.

**Organization** The manual for the RY7011 is this hardware manual. The RY7011 incorporates the RL78/G1D. The RL78/G1D manual is separated into two parts: the hardware edition and the software edition (common to the RL78 family).  
Moreover, there is Bluetooth® Low Energy protocol stack user's manual for using RF transceiver function of the RY7011.

<b>RY7011 User's Manual Hardware</b>	<b>RL78/G1D User's Manual Hardware</b>	<b>RL78 family User's Manual Software</b>	<b>Bluetooth® Low Energy protocol stack user's manual</b>
--	--	---	---

- |  |  |   |   |
|--|--|---|---|
| <ul style="list-style-type: none"><li>● Pin functions</li><li>● Internal block functions</li><li>● Deferences from RL78/G1D</li><li>● Electrical specifications</li><li>● Examples of application circuits</li></ul> | <ul style="list-style-type: none"><li>● Pin functions</li><li>● Internal block functions</li><li>● Interrupts</li><li>● Other on-chip peripheral functions</li><li>● Electrical specifications</li></ul> | <ul style="list-style-type: none"><li>● CPU functions</li><li>● Instruction set</li><li>● Explanation of each instruction</li></ul> | <ul style="list-style-type: none"><li>● Install</li><li>● Construction</li><li>● How to make execution file</li><li>● Description of function</li></ul> |
|--|--|---|---|

<b>RL78/G1D Module Firmware User's Manual</b>
---

- Firmware Specification
- Connection with the Host MCU
- Simplified Bi-directional Communication
- Bluetooth Device Address

**How to Read This Manual** It is assumed that the readers of this manual have general knowledge of electrical engineering, logic circuits, and microcontrollers.

- To gain a general understanding of functions:
  - Read this manual in the order of the **CONTENTS**. The mark "<R>" shows major revised points. The revised points can be easily searched by copying an "<R>" in the PDF file and specifying it in the "Find what:" field.
- To know details of the RL78/G1D Microcontroller instructions:
  - Refer to the separate document **RL78 Family Software User's Manual (R01US0015E)**.

**Conventions**

Active low representations:  $\overline{xxx}$ (overscore over pin and signal name)

**Note:** Footnote for item marked with **Note** in the text

**Caution:** Information requiring particular attention

**Related Documents**      The related documents indicated in this publication may include preliminary versions. However, preliminary versions are not marked as such.

**Documents Related to Devices**

Document Name	Document No.
RY7011 User's Manual Hardware	This manual
RL78/G1D User's Manual Hardware	R01UH0515E
RL78 Family Software User's Manual	R01US0015E
RL78/G1D Module Firmware User's Manual	R01UW0160E

**Documents Related to Flash Memory Programming**

Document Name	Document No.
PG-FP6 Flash Memory Programmer User's Manual	R20UT4025E
E1, E20 Emulator User's Manual	R20UT0398E
E2 Emulator User's Manual	R20UT3538E
E2 Lite Emulator User's Manual	R20UT3240E
Renesas Flash Programmer Flash Memory Programming Software User's Manual	R20UT4066E
Renesas Flash Development Toolkit User's Manual	R20UT0508E

**Caution** The related documents listed above are subject to change without notice. Be sure to use the latest version of each document when designing.

**Other Documents**

Document Name	Document No.
RENESAS MPUs & MCUs RL78 Family	R01CP0003E
Semiconductor Reliability Handbook	R51ZZ0001E

**Caution** The related documents listed above are subject to change without notice. Be sure to use the latest version of each document when designing.

### Notes on using the RF

The use of wireless receivers and transmitters is restricted by international standards and domestic regulations. Wireless receivers and transmitters must therefore be used in accordance with the applicable laws and regulations of the country in which they are being used.

The following standards typically apply to the use of the 2.4 GHz band:

Japan: ARIB STD-T66

United States: FCC 47CFR part 15.207, part15.209 and part15.247

Europe: EN300 328 and EN 301 489

The *Bluetooth*<sup>®</sup> word mark and logos are registered trademarks owned by Bluetooth SIG, Inc. and any use of such marks by Renesas Electronics Corporation is under license.

Other trademarks and trade names are those of their respective owners.

SuperFlash is a registered trademark of Silicon Storage Technology, Inc. in several countries including the United States and Japan.

Caution: This product uses SuperFlash<sup>®</sup> technology licensed from Silicon Storage Technology, Inc.

## CONTENTS

<b>CHAPTER 1 OUTLINE</b> .....	<b>1</b>
<b>1.1 Features</b> .....	<b>1</b>
<b>1.2 Part Numbers</b> .....	<b>3</b>
<b>1.4 Pin Identification</b> .....	<b>5</b>
<b>1.5 Block Diagram</b> .....	<b>6</b>
<b>1.6 Outline of Functions</b> .....	<b>7</b>
<b>1.7 Differences from RL78/G1D</b> .....	<b>9</b>
1.7.1 I/O ports and pin functions .....	9
1.7.2 Clock .....	9
<b>CHAPTER 2 PIN FUNCTIONS</b> .....	<b>11</b>
<b>2.1 Pin Functions</b> .....	<b>11</b>
<b>2.2 Connection of Unused Pins</b> .....	<b>14</b>
<b>CHAPTER 3 FLASH MEMORY</b> .....	<b>15</b>
<b>3.1 Serial Programming Using Flash Memory Programmer</b> .....	<b>17</b>
3.1.1 Programming environment .....	18
3.1.2 Communication mode .....	18
<b>3.2 Serial Programming Using External Device (that Incorporates UART)</b> .....	<b>19</b>
3.2.1 Programming environment .....	19
3.2.2 Communication mode .....	20
<b>3.3 Connection of Pins on Board</b> .....	<b>21</b>
3.3.1 P40/TOOL0 pin .....	21
3.3.2 RESET pin.....	21
3.3.3 Port pins .....	22
3.3.4 Power supply.....	22
<b>3.4 Serial Programming Method</b> .....	<b>23</b>
3.4.1 Serial programming procedure .....	23
3.4.2 Flash memory programming mode.....	24
3.4.3 Selecting communication mode.....	26
3.4.4 Communication commands .....	26
<b>3.5 Processing Time for Each Command When PG-FP5 Is in Use (Reference Value)</b> .....	<b>28</b>
<b>3.6 Self-Programming</b> .....	<b>29</b>
3.6.1 Self-programming procedure.....	30
3.6.2 Boot swap function .....	31
3.6.3 Flash shield window function.....	33
<b>3.7 Security Settings</b> .....	<b>34</b>

3.8 Data Flash .....	36
3.8.1 Data flash overview .....	36
3.8.2 Register controlling data flash memory .....	37
3.8.3 Procedure for accessing data flash memory .....	38
<b>CHAPTER 4 ELECTRICAL SPECIFICATIONS .....</b>	<b>39</b>
4.1 Absolute Maximum Ratings .....	39
4.2 Operating Voltage.....	39
4.3 Oscillator Characteristics .....	39
4.4 RF Transceiver Characteristics .....	40
4.4.1 RF transmission characteristics .....	40
4.4.2 RF reception characteristics .....	40
<b>CHAPTER 5 PACKAGE RELATED INFORMATION.....</b>	<b>41</b>
5.1 Module Drawings.....	41
5.2 Marking.....	42
5.3 Foot Pattern (Top View: For Reference).....	42
<b>CHAPTER 6 EXAMPLES OF APPLICATION CIRCUITS.....</b>	<b>43</b>
<b>CHAPTER 7 SOLDERING CONDITION.....</b>	<b>46</b>
7.1 Soldering Method .....	46
7.2 Maximum Reflow Times.....	46
7.3 Recommended Temperature Profile.....	46
<b>CHAPTER 8 PACKAGING .....</b>	<b>47</b>
8.1 Quantity of Components to Be Packaged.....	47
8.2 Carrier Tape and Reel Dimensions.....	48
8.3 Taping Direction .....	49
8.4 Peel Strength of Cover Tape .....	49
8.5 Packaging Specifications .....	50
8.6 Storage Conditions .....	51
<b>CHAPTER 9 CERTIFICATION OF COMPLIANCE .....</b>	<b>52</b>
9.1 Radio-Related Laws .....	52
9.2 Bluetooth SIG Certification .....	52
9.3 Labeling and Requirement for User Information .....	52
<b>CHAPTER 10 NOTES ON LAYOUT.....</b>	<b>57</b>
10.1 Main Board Design .....	57



<b>10.2 Housing Design .....</b>	<b>58</b>
<b>10.3 Layout of the Crystal Resonator for the External Subsystem Clock.....</b>	<b>58</b>
<b>10.4 Handling of IC Pin.....</b>	<b>59</b>
<b>10.5 Designing the Power Supply System .....</b>	<b>59</b>
<b>APPENDIX A REVISION HISTORY .....</b>	<b>60</b>
<b>A.1 Major Revisions in This Edition .....</b>	<b>60</b>
<b>A.2 Revision History of Preceding Edition .....</b>	<b>61</b>

## CHAPTER 1 OUTLINE

The RY7011 is a Bluetooth low energy module incorporating the RL78/G1D, a 32-MHz crystal resonator for the RF chip, and an antenna.

This module has obtained certificates of compliance with Japan's Radio Law, the FCC's module-related standards, IC regulation, CE mark requirements, and the Bluetooth v4.1 specification, so you can use it now.

### 1.1 Features

Ultra-low power consumption technology (3.0 V/MCU part: STOP mode)

- RF transmission: 4.3 mA (TYP.)
- RF reception: 3.5 mA (TYP.)
- RF sleep (POWER\_DOWN mode): 0.3  $\mu$ A (TYP.)

On-chip RF transceiver

- Bluetooth v4.2 Specification (Low Energy Single mode)
- 2.4 GHz ISM band, GFSK modulation, TDMA/TDD frequency hopping (including AES encryption circuit)
- Adaptability (only in slave operation)

Code flash memory

- 256 KB (block size: 1 KB)

Data flash memory

- Data flash memory: 8 KB

RAM

- 20 KB

Operating clock

- High-speed on-chip oscillator (selectable from among 32 MHz, 24 MHz, 16 MHz, 12 MHz, 8 MHz, 6 MHz, 4 MHz, 3 MHz, 2 MHz, and 1 MHz): For MCU operation
- Subsystem clock (32.768 kHz): For MCU operation and the RF slow clock
  - External clock input
  - External crystal resonator connection

Small pattern antenna mounted

Software written to the module as shipped

The module is shipped with software for verifying operation written to it. Verify the operation of the module before using it.

- The RL78/G1D module firmware has been written<sup>Note</sup>.

**Note** See the RL78/G1D Module Firmware User's Manual.

Development environment

With regard to various information on settings of device files, parameter files, and so on which are used in software development of the MCU and writing of programs, use ones which support the R5F11AGJDNB<sup>Note</sup>.

**Note** RL78/G1D product with 256 Kbytes of code flash memory for industrial applications

Certificates of compliance with radio-related laws

Japan: Type certification (authentication number: 007-AE0104)

North America: FCC (FCC ID: 2AEMXY7011A00000), IC (20194-Y7011A00000)

Europe: CE (RED)

Bluetooth SIG certificate has been obtained.

QDID: 82194

Operating environment

- Voltage: 1.6 to 3.6 V<sup>Note</sup>
- Temperature: -25 to +75°C

**Note** When the on-chip DC-DC converter is not in use (1.8 to 3.6 V when the on-chip DC-DC converter is in use)

Pin count

- 42 pins

Field of application (quality grade)

- For electronic equipment for general consumer applications) (standard)

1.2 Part Numbers

Figure 1 – 1 Part Numbers of RY7011

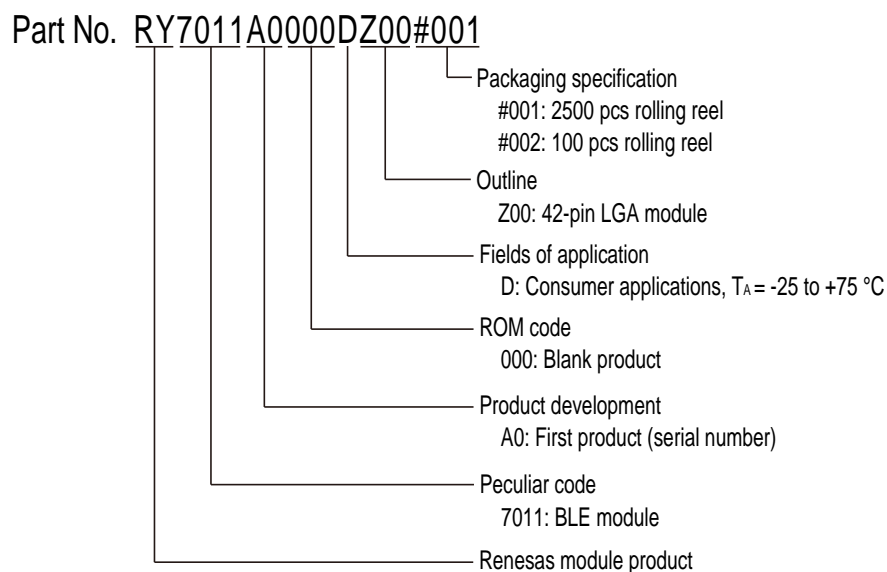
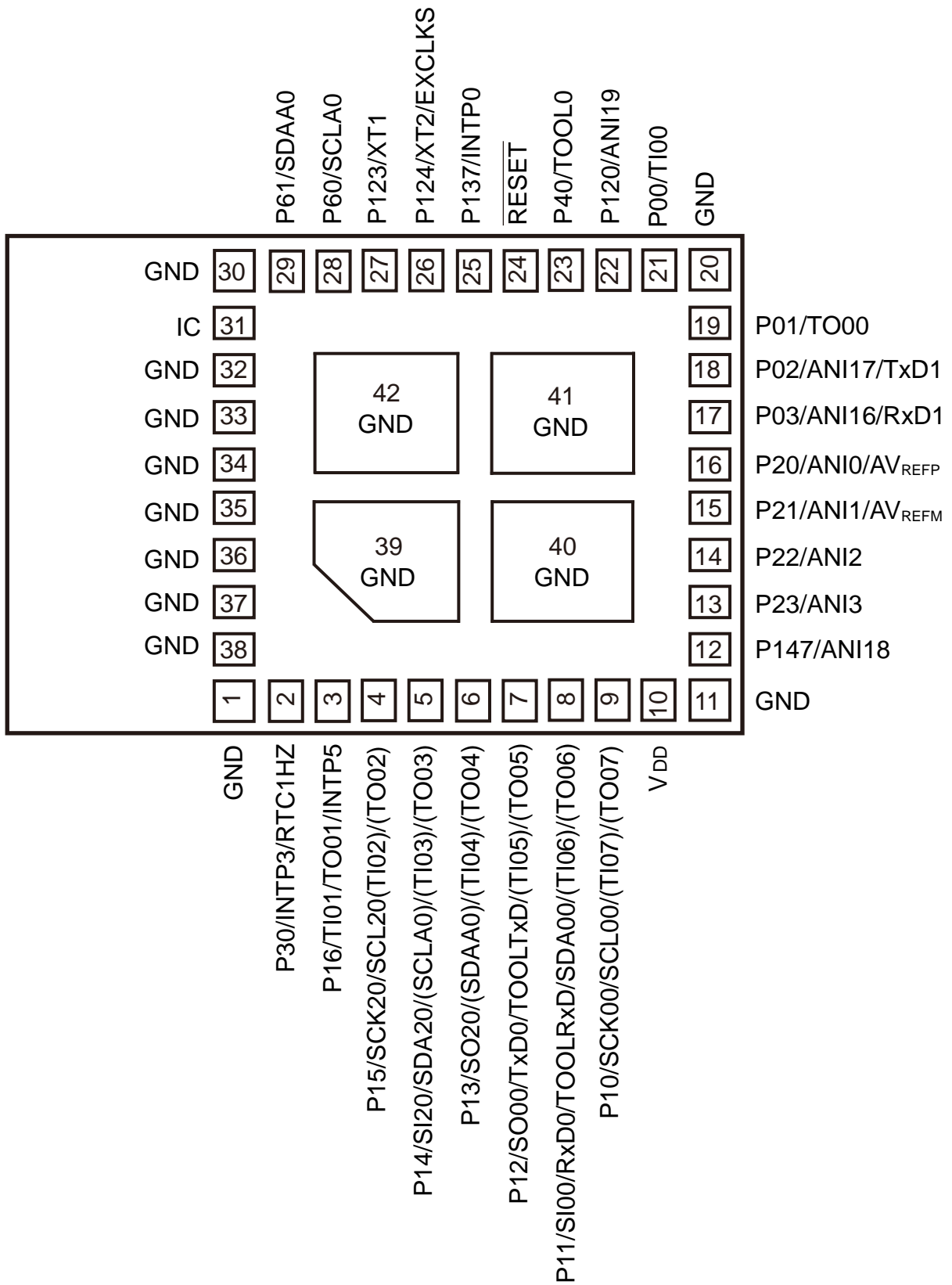

Table 1 – 1 List of Ordering Part Numbers

Pin count	Module	Fields of application	Part number	Code flash memory	Data flash memory	Packaging specification
42 pins	Metal cap type	Consumer applications	RY7011A0000DZ00#001	256 Kbytes	8 Kbytes	2500 pcs rolling reel
			RY7011A0000DZ00#002			100 pcs rolling reel

**Caution** These part numbers are identified at issuing of this manual. Latest part numbers are confirmed on the product page of Renesas Electronics’s web page.

1.3 Pin Configuration (Top View)



IC: Internally connected

## 1.4 Pin Identification

ANI0 to ANI3, ANI16 to ANI19:	Analog input
EXCLKS:	External clock input (subsystem clock)
INTP0, INTP3, INTP5:	External interrupt input
P00 to P03:	Port 0
P10 to P16:	Port 1
P20 to P23:	Port 2
P30:	Port 3
P40:	Port 4
P60, P61:	Port 6
P120, P123, P124:	Port 12
P137:	Port 13
P147:	Port 14
$\overline{\text{RESET}}$ :	Reset
RTC1HZ:	Real-Time clock correction clock (1 Hz) output
RxD0, RxD1:	Receive data
SCLA0:	Serial clock input/output
SCK00, SCK20, SCL00, SCL20:	Serial clock output
SDAA0, SDA00, SDA20:	Serial data input/output
SI00, SI20:	Serial data input
SO00, SO20:	Serial data output
TI00 to TI07:	Timer input
TO00 to TO07:	Timer output
TOOL0:	Data input/output for tool
TOOLRxD, TOOLTxD:	Data input/output for external device
TxD0, TxD1:	Transmit data
V <sub>DD</sub> :	Power supply
GND:	Ground
XT1, XT2:	Crystal oscillator (subsystem clock)

1.5 Block Diagram <sup>Note 1</sup>

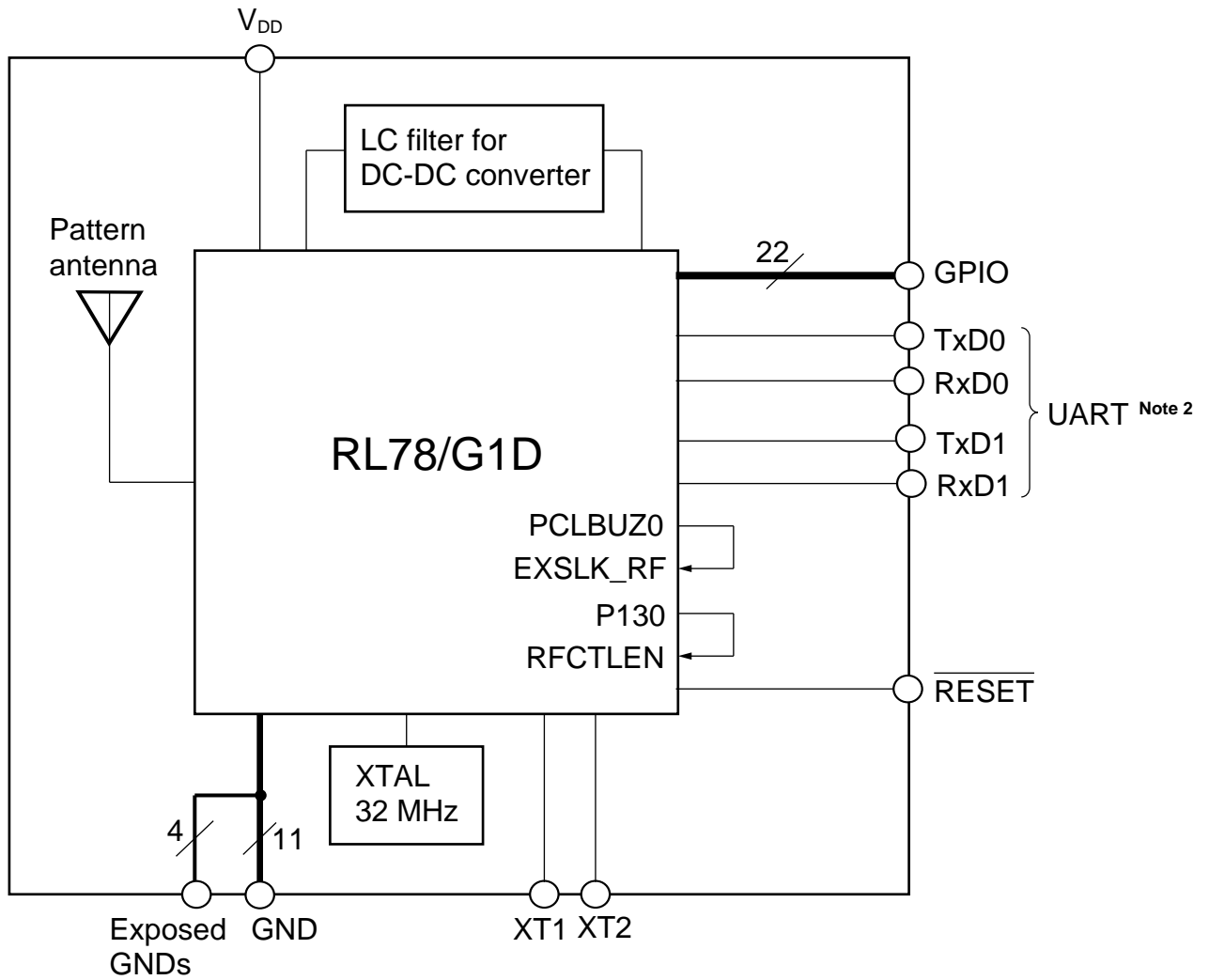

- Notes**
- Software written to the module as shipped realizes simple transmission and reception of data in combination with the host MCU.  
This software runs with a 32-kHz on-chip oscillator for the RF slow clock.
  - The UART is assumed to be connected to the host MCU.  
The Tx/D1 and Rx/D1 (UART1) pins are not used in the software written to the module as shipped.

## 1.6 Outline of Functions

The following functions can be realized because of development of firmware. For details, see the RL78/G1D User's Manual: Hardware (R01UH0515E).

Code flash memory:	256 KB
Data flash memory:	8 KB
RAM:	20 KB
Address space:	1 MB

Main system clock (high-speed on-chip oscillator)

HS (high-speed main) mode:	1 to 32 MHz ( $V_{DD} = 2.7$ to 3.6 V), 1 to 16 MHz ( $V_{DD} = 2.4$ to 3.6 V)
LS (low-speed main) mode:	1 to 8 MHz ( $V_{DD} = 1.8$ to 3.6 V)
LV (low-voltage main) mode:	1 to 4 MHz ( $V_{DD} = 1.6$ to 3.6 V)

Subsystem clock: 32.768 kHz (RF slow clock)

XT1 (crystal) oscillation
External subsystem clock input (EXCLKS)

General-purpose register: (8-bit register × 8) × 4 banks

Number of I/O ports<sup>Note</sup>

CMOS I/O:	21				
<table> <tr> <td>CMOS output:</td> <td>19</td> </tr> <tr> <td>N-ch open drain output (withstand voltage of 6 V):</td> <td>2</td> </tr> </table>	CMOS output:	19	N-ch open drain output (withstand voltage of 6 V):	2	
CMOS output:	19				
N-ch open drain output (withstand voltage of 6 V):	2				
CMOS input:	3				
Total:	24				

**Note** When the setting of PIOR0 is 1.

2.4 GHz RF transceiver

Supporting Bluetooth v4.2 Specification (Low Energy Single mode)
2.4 GHz ISM band, GFSK modulation, TDMA/TDD frequency hopping (including AES encryption circuit)
Adaptability (only in slave operation)



## Timer

16-bit timer:	8 channels
Watchdog timer:	1 channel
Real-time clock (RTC):	1 channel
12-bit interval timer:	1 channel
Timer output:	8 channels (PWM output: 7 <sup>Note</sup> )
Real-time clock (RTC) output:	1 channel, 1 Hz (source: subsystem clock $f_{SUB} = 32.768$ kHz)

**Note** The number of PWM outputs varies depending on the setting of channels in use (the master channel and the number of slave channels).

8/10-bit resolution A/D converter: 8 channels

## Serial interface

CSI/simplified I <sup>2</sup> C/UART:	1 channel
CSI/simplified I <sup>2</sup> C:	1 channel
UART:	1 channel
I <sup>2</sup> C bus:	1 channel

## Multiplier and divider/multiply-accumulator

Multiplication:	$16 \text{ bits} \times 16 \text{ bits} = 32 \text{ bits}$ (unsigned or signed)
Division:	$32 \text{ bits} \div 32 \text{ bits} = 32 \text{ bits}$ (unsigned)
Multiply-accumulate:	$16 \text{ bits} \times 16 \text{ bits} + 32 \text{ bits} = 32 \text{ bits}$ (unsigned or signed)

DMA controller: 4 channels

## Vectored interrupt sources

Internal:	29
External:	3

## Reset source

- External reset
  - RESET signal input
- Internal reset
  - Watchdog timer
  - Power-on-reset
  - Voltage detector
  - Illegal instruction execution<sup>Note</sup>
  - RAM parity error
  - Illegal-memory access

**Note** The illegal instruction is generated when instruction code FFH is executed.

A reset due to the illegal instruction execution is not issued in emulating with the on-chip debug emulator.

Power-on-reset circuit

Power-on-reset: 1.51 V (TYP.)

Power-down-reset: 1.50 V (TYP.)

Voltage detector

Rising edge: 1.67 to 3.13 V (12 stages)

Falling edge: 1.63 to 3.06 V (12 stages)

On-chip debug function: Provided

Power supply voltage:  $V_{DD} = 1.6$  to  $3.6$  V ( $V_{DD} = 1.8$  to  $3.6$  V on usage of the DC-DC converter)

Operating ambient temperature:  $T_A = -25$  to  $+75^\circ\text{C}$

## 1.7 Differences from RL78/G1D

The following shows the differences in function between this module and the RL78/G1D.

For functions of RL78/G1D, see RL78/G1D User's Manual Hardware (R01UH0515E).

### 1.7.1 I/O ports and pin functions

The port and pin functions listed below are not available.

GPIO0/TXSELH\_RF

GPIO1/TXSELL\_RF

GPIO2/CLKOUT\_RF

GPIO3/EXSLK\_RF

IC0

IC1

P121/X1

P122/X2/EXCLK

P130

RFCTLEN

P140/PCLBUZ0/INTP6

### 1.7.2 Clock

(1) Main system clock

Only the high-speed on-chip oscillator clock is available. This module does not support X1 (crystal/ceramic) oscillation and external main system clock input (EXCLK).

(2) Crystal oscillator for the RF chip

This module has a 32-MHz oscillator circuit and crystal resonator for the RF chip.

(3) On-chip local oscillator

The EXSLK\_RF and PCLBUZ0 pins of the RL78/G1D are connected with each other. Accordingly a 32.768-kHz crystal resonator should be connected with the XT1 or XT2 pin, or a 32.768-kHz clock signal should be input on the EXCLKS pin.

For this module, the signal equivalent to PCLBUZ0 is input to the on-chip local oscillator (32.768 kHz).

## CHAPTER 2 PIN FUNCTIONS

## 2.1 Pin Functions

The software written to the module as shipped selects the pin functions underlined in the table below.

(1/3)

Pin No.	Pin Name	Function
1	GND	Ground potential
2	P30/INTP3/RTC1HZ	<u>Port P30 input (enabled on-chip pull-up resistor)</u> External interrupt request input 3 Real-time clock correction clock (1 Hz) output
3	P16/TI01/TO01/INTP5	<u>Port P16 input (enabled on-chip pull-up resistor)</u> External count clock/capture trigger input to 16-bit timer 01 Timer output of 16-bit timer 01 External interrupt request input 5
4	P15/SCK20/SCL20(TI02)/(TO02)	<u>Port P15 input (enabled on-chip pull-up resistor)</u> Clock I/O of serial interface CSI20 Clock output of serial interface IIC20 External count clock/capture trigger input to 16-bit timer 02 Timer output of 16-bit timer 02
5	P14/SI20/SDA20/(SCLA0)/(TI03)/(TO03)	<u>Port P14 input (enabled on-chip pull-up resistor)</u> Serial data input of serial interface CSI20 Serial data I/O of serial interface IIC20 Clock I/O of serial interface IICA0 External count clock/capture trigger input to 16-bit timer 03 Timer output of 16-bit timer 03
6	P13/SO20/(SDAA0)/(TI04)/(TO04)	<u>Port P13 input (enabled on-chip pull-up resistor)</u> Serial data output of serial interface CSI20 Serial data I/O of serial interface IICA0 External count clock/capture trigger input to 16-bit timer 04 Timer output of 16-bit timer 04
7	P12/SO00/TxD0/TOOLTxD/(TI05)/(TO05)	Port P12 Serial data output of serial interface CSI00 <u>Serial data output of serial interface UART0</u> UART serial transmission for external device connection used during flash memory programming External count clock/capture trigger input to 16-bit timer 05 Timer output of 16-bit timer 05
8	P11/SI00/RxD0/TOOLRxD/SDA00/(TI06)/(TO06)	Port P11 Serial data input of serial interface CSI00 <u>Serial data input of serial interface UART0</u> UART serial data reception for external device connection used during flash memory programming Serial data I/O of serial interface IIC00 External count clock/capture trigger input to 16-bit timer 06 Timer output of 16-bit timer 06

(2/3)

Pin No.	Pin Name	Function
9	P10/SCK00/SCL00/(TI07)/(TO07)	<p><u>Port P10 input (enabled on-chip pull-up resistor)</u></p> <p>Clock I/O of serial interface CSI00</p> <p>Clock output of serial interface IIC00</p> <p>External count clock/capture trigger input to 16-bit timer 07</p> <p>Timer output of 16-bit timer 07</p>
10	V <sub>DD</sub>	Positive power supply
11	GND	Ground potential
12	P147/ANI18	<p><u>Port P147 input (enabled on-chip pull-up resistor)</u></p> <p>A/D converter analog input 18</p> <p>Do not pull down this pin while the software written to the module as shipped is in use. Otherwise, the software will not run properly.</p>
13	P23/ANI3	<p><u>Port P23 output</u></p> <p>A/D converter analog input 3</p>
14	P22/ANI2	<p><u>Port P22 output</u></p> <p>A/D converter analog input 2</p>
15	P21/ANI1/AVREFM	<p><u>Port P21 output</u></p> <p>A/D converter analog input 1</p> <p>A/D converter reference potential (- side) input</p>
16	P20/ANI0/AVREFP	<p><u>Port P20 output</u></p> <p>A/D converter analog input 0</p> <p>A/D converter reference potential (+ side) input</p>
17	P03/ANI16/RxD1	<p><u>Port P03 output</u></p> <p>A/D converter analog input 16</p> <p>Serial data input of serial interface UART1</p>
18	P02/ANI17/TxD1	<p><u>Port P02 (enabled on-chip pull-up resistor)</u></p> <p>A/D converter analog input 17</p> <p>Serial data output of serial interface UART1</p>
19	P01/TO00	<p><u>Port P01 input (enabled on-chip pull-up resistor)</u></p> <p>Timer output of 16-bit timer 00</p>
20	GND	Ground potential
21	P00/TI00	<p><u>Port P00 input (enabled on-chip pull-up resistor)</u></p> <p>External count clock/capture trigger input to 16-bit timer 00</p>
22	P120/ANI19	<p><u>Port P120 output</u></p> <p>A/D converter analog input 19</p>
23	P40/TOOL0	<p><u>Port P40 input</u></p> <p>Data I/O for flash memory programmer/debugger</p> <p>In the flash memory programming mode, connect this pin to V<sub>DD</sub> via a 1-kΩ resistor, and to the dedicated flash memory programmer.</p> <p>For notes when this pin is used as a port pin in normal operation mode, see the RL78/G1D User's Manual: Hardware (R01UH0515E).</p>
24	RESET	<p>This is the active-low system reset input pin.</p> <p>When the external reset pin is not used, connect this pin directly or via a resistor to V<sub>DD</sub>. For details, see the RL78/G1D User's Manual: Hardware (R01UH0515E).</p>

(3/3)

Pin No.	Pin Name	Function
25	P137/INTP0	<u>Port P137 input</u> External interrupt request input 0
26	P124/XT2/EXCLKS	<u>Port P124 input</u> Resonator connection for subsystem clock External clock input for subsystem clock
27	P123/XT1	<u>Port P123 input</u> Resonator connection for subsystem clock
28	P60/SCLA0	<u>Port P60 input</u> Clock I/O of serial interface IICA0
29	P61/SDAA0	<u>Port P61 input</u> Serial data I/O of serial interface IICA0
30	GND	Ground potential
31	IC	Not used (internal circuit connection): Leave open
32 to 42	GND	Ground potential

## 2.2 Connection of Unused Pins

Table 2 – 1 shows the connections of unused pins.

**Table 2 – 1 Connection of Unused Pins**

Pin Name	I/O	Recommended Connection of Unused Pins
P00/TI00	I/O	Input: Independently connect to $V_{DD}$ or GND via a resistor. Output: Leave open.
P01/TO00		
P02/ANI17/TxD1		
P03/ANI16/RxD1		
P10/SCK00/SCL00/(TI07)/(TO07)		Input: Independently connect to $V_{DD}$ or GND via a resistor. Output: Leave open.
P11/SI00/RxD0/TOOLRxD/ SDA00/(TI06)/(TO06)		
P12/SO00/TxD0/TOOLTxD/(TI05)/(TO05)		
P13/SO20/(SDAA0)/(TI04)/(TO04)		
P14/SI20/SDA20/(SCLA0)/(TI03)/(TO03)		
P15/SCK20/SCL20/(TI02)/(TO02)		
P16/TI01/INTP5		Input: Independently connect to $V_{DD}$ or GND via a resistor. Output: Leave open.
P20/ANI0/AV <sub>REFP</sub>		Input: Independently connect to $V_{DD}$ or GND via a resistor. Output: Leave open.
P21/ANI1/AV <sub>REFM</sub>		
P22/ANI2		Input: Independently connect to $V_{DD}$ or GND via a resistor. Output: Leave open.
P23/ANI3		
P30/INTP3	Input: Independently connect to $V_{DD}$ or GND via a resistor. Output: Leave open.	
P40/TOOL0	Input: Independently connect to $V_{DD}$ or leave open. Output: Leave open.	
P60/SCLA0	Input: Independently connect to $V_{DD}$ or GND via a resistor. Output: Set the port's output latch to 0 and leave the pins open, or set the port's output latch to 1 and independently connect the pins to $V_{DD}$ or GND via a resistor.	
P61/SDAA0		
P120/ANI19	I/O	Input: Independently connect to $V_{DD}$ or GND via a resistor. Output: Leave open.
P123/XT1	Input	Independently connect to $V_{DD}$ or GND via a resistor.
P124/XT2/EXCLKS		
P137/INTP0	Input	Independently connect to $V_{DD}$ or GND via a resistor.
P147/ANI18	I/O	Input: Independently connect to $V_{DD}$ via a resistor. Output: Leave open.
RESET	Input	Connect directly or via a resistor to $V_{DD}$ .
IC	—	Unused (connected internally): Leave open.

**CHAPTER 3 FLASH MEMORY**

The RL78 microcontroller incorporates the flash memory to which a program can be written, erased, and rewritten. The flash memory includes the “code flash memory”, in which programs can be executed, and the “data flash memory”, an area for storing data.

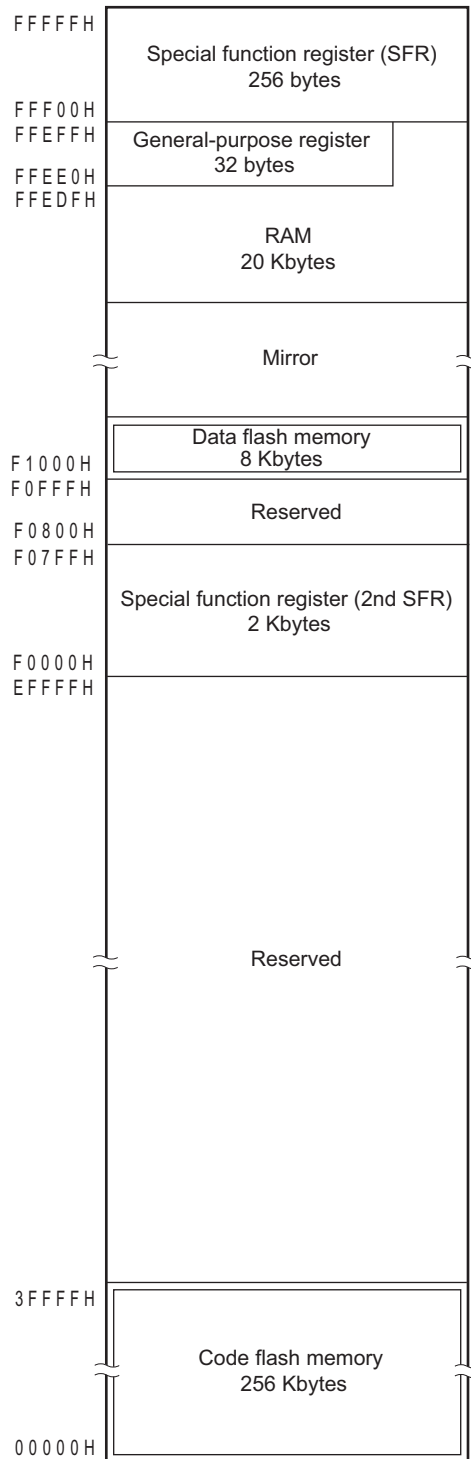



The following methods for programming the flash memory are available.

The code flash memory can be rewritten to through serial programming using a flash memory programmer or an external device (UART communication), or through self-programming.

- Serial programming using flash memory programmer (see 3.4)

Data can be written to the flash memory on-board or off-board by using a dedicated flash memory programmer.

- Serial programming using external device (UART communication) (see 3.2)

Data can be written to the flash memory on-board through UART communication with an external device (microcontroller or ASIC).

- Self-programming (see 3.6)

The user application can execute self-programming of the code flash memory by using the flash self-programming library.

The data flash memory can be rewritten to by using the data flash library during user program execution (background operation). For access and writing to the data flash memory, see 3.8 **Data Flash**.

### 3.1 Serial Programming Using Flash Memory Programmer

The following dedicated flash memory programmer can be used to write data to the internal flash memory of the RL78 microcontroller.

- PG-FP6, FL-PR6
- E1, E2, E2 Lite and E20 on-chip debugging emulators

Data can be written to the flash memory on-board or off-board, by using a dedicated flash memory programmer.

#### (1) On-board programming

The contents of the flash memory can be rewritten after the RL78 microcontroller has been mounted on the target system. The connectors that connect the dedicated flash memory programmer must be mounted on the target system.

#### (2) Off-board programming

Data can be written to the flash memory before the RL78 microcontroller is mounted on the target system.

**Remark** FL-PR6 is produced by Naito Densai Machida Mfg. Co., Ltd.

**Table 3 – 1 Wiring Between RL78/G1D Module and Dedicated Flash Memory Programmer**

Pin Configuration of Dedicated Flash Memory Programmer				Pin Name	Pin No.
Signal Name		I/O	Pin Function		
PG-FP6, FL-PR6	E1, E2, E2 Lite, E20 on-chip debugging emulators				
—	TOOL0	I/O	Transmit/receive signal	TOOL0/ P40	23
SI/RxD	—	I/O	Transmit/receive signal		
—	RESET	Output	Reset signal	RESET	24
/RESET	—	Output			
V <sub>DD</sub>		I/O	V <sub>DD</sub> voltage generation/ power monitoring	V <sub>DD</sub>	10
GND		—	Ground	GND	11, 20, 30, 32-42
FLMD1	EMV <sub>DD</sub>	—	Driving power for TOOL0 pin	V <sub>DD</sub>	10

**Remark** Pins that are not indicated in the above table can be left open when using the flash memory programmer for flash programming.

### 3.1.1 Programming environment

The environment required for writing a program to the flash memory of the RL78 microcontroller incorporated in RL78/G1D Module is illustrated below.

**Figure 3 – 1 Environment for Writing Program to Flash Memory**

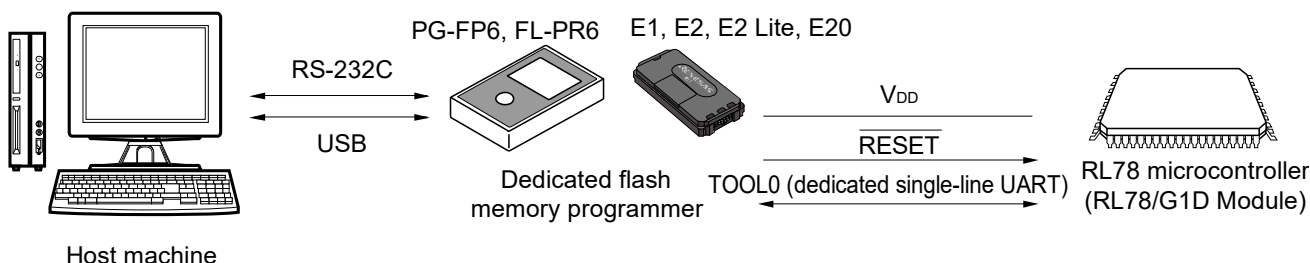

A host machine that controls the dedicated flash memory programmer is necessary.

To interface between the dedicated flash memory programmer and the RL78 microcontroller, the TOOL0 pin is used for manipulation such as writing and erasing via a dedicated single-line UART.

### 3.1.2 Communication mode

Communication between the dedicated flash memory programmer and the RL78 microcontroller is established by serial communication using the TOOL0 pin via a dedicated single-line UART of the RL78 microcontroller.

Transfer rate: 1 M, 500 k, 250 k, 115.2 kbps

**Figure 3 – 2 Communication with Dedicated Flash Memory Programmer**

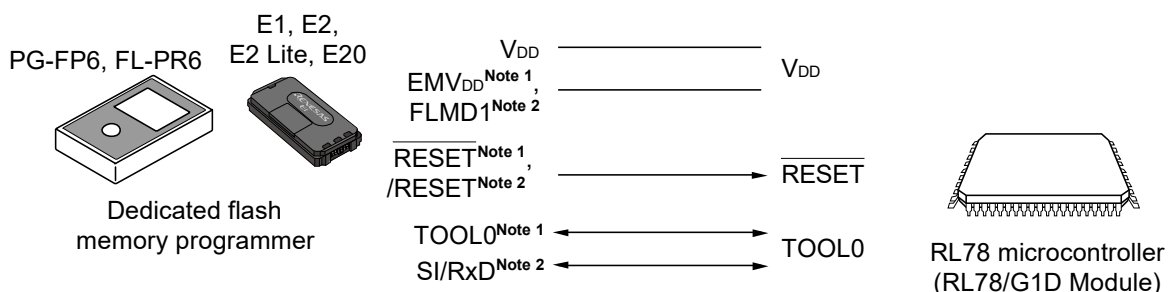

- Notes 1.** When using E1, E2, E2 Lite or E20 on-chip debugging emulator.
- 2.** When using PG-FP6 or FL-PR6.

The dedicated flash memory programmer generates the following signals for the RL78 microcontroller. See each manual of PG-FP6, FL-PR6, or E1, E2, E2 Lite, E20 on-chip debugging emulators for details.

**Table 3 – 2 Pin Connections**

Dedicated Flash Memory Programmer			RL78 Microcontroller	
Signal Name		I/O	Pin Function	Pin Name
PG-FP6, FL-PR6	E1, E2, E2 Lite, E20 on-chip debugging emulators			
V <sub>DD</sub>		I/O	V <sub>DD</sub> voltage generation/power monitoring	V <sub>DD</sub>
GND		—	Ground	GND
FLMD1	EMV <sub>DD</sub>	—	Driving power for TOOL0 pin	V <sub>DD</sub>
/RESET	—	Output	Reset signal	RESET
—	RESET	Output		
—	TOOL0	I/O	Transmit/receive signal	TOOL0
SI/RxD	—	I/O	Transmit/receive signal	

### 3.2 Serial Programming Using External Device (that Incorporates UART)

On-board data writing to the internal flash memory is possible by using the RL78 microcontroller and an external device (a microcontroller or ASIC) connected to a UART.

On the development of flash memory programmer by user, refer to the **RL78 Microcontrollers (RL78 Protocol A) Programmer Edition Application Note (R01AN0815)**.

#### 3.2.1 Programming environment

The environment required for writing a program to the flash memory of the RL78 microcontroller is illustrated below.

**Figure 3 – 3 Environment for Writing Program to Flash Memory**

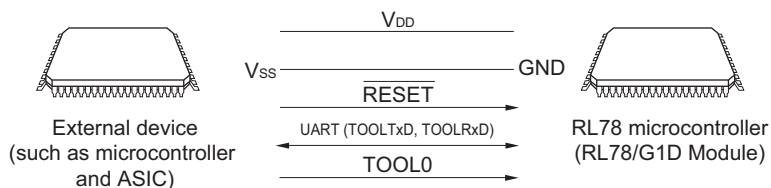

Processing to write data to or erase data from the RL78 microcontroller by using an external device is performed on-board. Off-board writing is not possible.

**3.2.2 Communication mode**

Communication between the external device and the RL78 microcontroller is established by serial communication using the TOOLTxD and TOOLRxD pins via the dedicated UART of the RL78 microcontroller.

Transfer rate: 1 M, 500 k, 250 k, 115.2 kbps

**Figure 3 – 4. Communication with External Device**

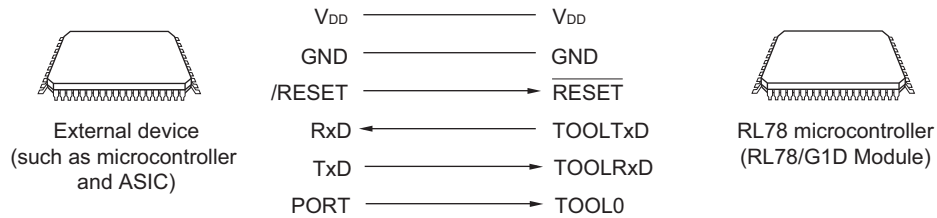

The external device generates the following signals for the RL78 microcontroller.

**Table 3 – 3. Pin Connections**

External Device			RL78 Microcontroller
Signal Name	I/O	Pin Function	Pin Name
V <sub>DD</sub>	I/O	V <sub>DD</sub> voltage generation/power monitoring	V <sub>DD</sub>
GND	—	Ground	GND
RESETOUT	Output	Reset signal output	RESET
RxD	Input	Receive signal	TOOLTxD
TxD	Output	Transmit signal	TOOLRxD
PORT	Output	Mode signal	TOOL0

### 3.3 Connection of Pins on Board

To write the flash memory on-board by using the flash memory programmer, connectors that connect the dedicated flash memory programmer must be provided on the target system. First provide a function that selects the normal operation mode or flash memory programming mode on the board.

When the flash memory programming mode is set, all the pins not used for programming the flash memory are in the same status as immediately after reset. Therefore, if the external device does not recognize the state immediately after reset, the pins must be handled as described below.

**Remark** For the flash memory programming mode, see 3.4.2 **Flash memory programming mode**.

#### 3.3.1 P40/TOOL0 pin

In the flash memory programming mode, connect this pin to the dedicated flash memory programmer via an external 1 k $\Omega$  pull-up resistor.

When this pin is used as the port pin, use that by the following method.

When used as an input pin: Input of low-level is prohibited for  $t_{HD}$  period after external pin reset release. However, when this pin is used via pull-down resistors, use the 500 k $\Omega$  or more resistors.

When used as an output pin: When this pin is used via pull-down resistors, use the 500 k $\Omega$  or more resistors.

- Remarks**
1.  $t_{HD}$ : How long to keep the TOOL0 pin at the low level from when the external and internal resets end for setting of the flash memory programming mode (see **30.13 Timing of Entry to Flash Memory Programming Modes** of the RL78/G1D User's Manual: Hardware)
  2. The SAU and IICA pins are not used for communication between the RL78 microcontroller and dedicated flash memory programmer, because single-line UART (TOOL0 pin) is used.

#### 3.3.2 $\overline{\text{RESET}}$ pin

Signal conflict will occur if the reset signal of the dedicated flash memory programmer and external device are connected to the  $\overline{\text{RESET}}$  pin that is connected to the reset signal generator on the board. To prevent this conflict, isolate the connection with the reset signal generator.

The flash memory will not be correctly programmed if the reset signal is input from the user system while the flash memory programming mode is set. Do not input any signal other than the reset signal of the dedicated flash memory programmer and external device.

**Figure 3 – 5 Signal Conflict ( $\overline{\text{RESET}}$  Pin)**

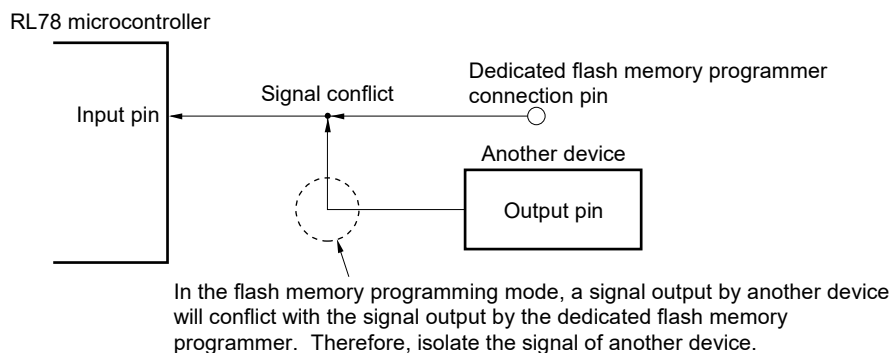

### 3.3.3 Port pins

When the flash memory programming mode is set, all the pins not used for flash memory programming enter the same status as that immediately after reset. If external devices connected to the ports do not recognize the port status immediately after reset, the port pin must be connected to  $V_{DD}$  or to GND via a resistor.

### 3.3.4 Power supply

To use the supply voltage output of the flash memory programmer, connect the  $V_{DD}$  pin to  $V_{DD}$  of the flash memory programmer, and the GND pin to GND of the flash memory programmer.

To use the on-board supply voltage, connect in compliance with the normal operation mode.

However, when writing to the flash memory by using the flash memory programmer and using the on-board supply voltage, be sure to connect the  $V_{DD}$  and GND pins to  $V_{DD}$  and GND of the flash memory programmer to use the power monitor function with the flash memory programmer.

### 3.4 Serial Programming Method

#### 3.4.1 Serial programming procedure

The following figure illustrates a flow for rewriting the code flash memory through serial programming.

**Figure 3 – 6 Code Flash Memory Manipulation Procedure**

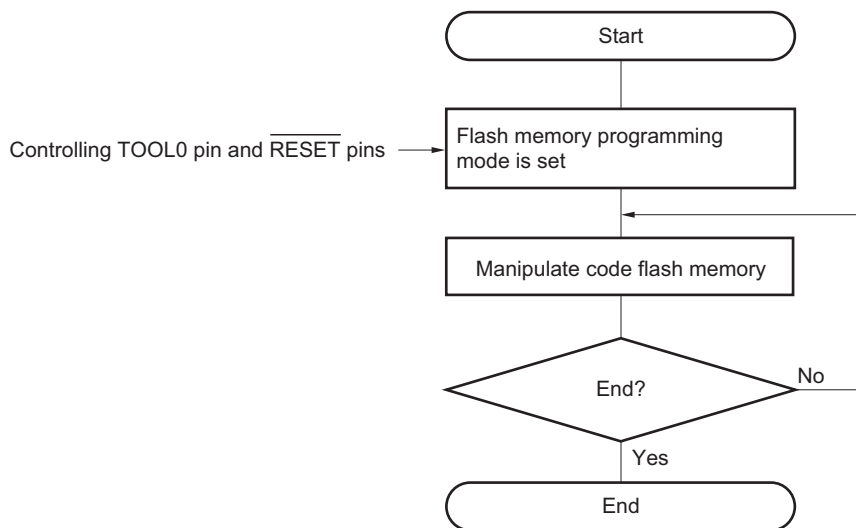



### 3.4.2 Flash memory programming mode

To rewrite the contents of the code flash memory through serial programming, set the RL78 microcontroller to the flash memory programming mode. To enter the mode, set as follows.

<Serial programming using the dedicated flash memory programmer>

Connect the RL78 microcontroller to a dedicated flash memory programmer. Communication from the dedicated flash memory programmer is performed to automatically switch to the flash memory programming mode.

<Serial programming using an external device (UART communication)>

Set the TOOL0 pin to the low level, and then cancel the reset (see **Table 3 – 4**). After that, enter flash memory programming mode according to the procedures <1> to <4> shown in **Figure 3 – 7**. For details, refer to the **RL78 Microcontrollers (RL78 Protocol A) Programmer Edition Application Note (R01AN0815)**.

**Table 3 – 4 Relationship between TOOL0 Pin and Operation Mode after Reset Release**

TOOL0	Operation Mode
V <sub>DD</sub>	Normal operation mode
0 V	Flash memory programming mode

**Figure 3 – 7 Setting of Flash Memory Programming Mode**

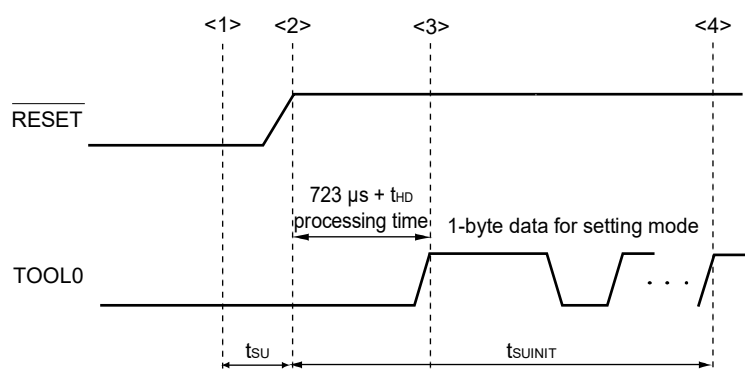

- <1> The low level is input to the TOOL0 pin.
- <2> The external reset ends (POR and LVD reset must end before the external reset ends.).
- <3> The TOOL0 pin is set to the high level.
- <4> Baud rate setting by UART reception is completed.

**Remark** *tsuINIT*: The segment shows that it is necessary to finish specifying the initial communication settings within 100 ms from when the resets end.

*tsu*: How long from when the TOOL0 pin is placed at the low level until an external reset ends

*t<sub>HD</sub>*: How long to keep the TOOL0 pin at the low level from when the external and internal resets end (the flash firmware processing time is excluded)

For details, see **30.13 Timing of Entry to Flash Memory Programming Modes** of the RL78/G1D User's Manual: Hardware.

There are two flash memory programming modes: wide voltage mode and full speed mode. The supply voltage value applied to the microcontroller during write operations and the setting information of the user option byte for setting of the flash memory programming mode determine which mode is selected.

When a dedicated flash memory programmer is used for serial programming, setting the voltage on GUI selects the mode automatically.

**Table 3 – 5 Programming Modes and Voltages at Which Data Can Be Written, Erased, or Verified**

Power Supply Voltage ( $V_{DD}$ )	User Option Byte Setting for Switching to Flash Memory Programming Mode		Flash Programming Mode
	Flash Operation Mode	Operating Frequency	
$2.7\text{ V} \leq V_{DD} \leq 3.6\text{ V}$	Blank state		Full speed mode
	HS (high speed main) mode	1 MHz to 32 MHz	Full speed mode
	LS (low speed main) mode	1 MHz to 8 MHz	Wide voltage mode
	LV (low voltage main) mode	1 MHz to 4 MHz	Wide voltage mode
$2.4\text{ V} \leq V_{DD} < 2.7\text{ V}$	Blank state		Full speed mode
	HS (high speed main) mode	1 MHz to 16 MHz	Full speed mode
	LS (low speed main) mode	1 MHz to 8 MHz	Wide voltage mode
	LV (low voltage main) mode	1 MHz to 4 MHz	Wide voltage mode
$1.8\text{ V} \leq V_{DD} < 2.4\text{ V}$	Blank state		Wide voltage mode
	LS (low speed main) mode	1 MHz to 8 MHz	Wide voltage mode
	LV (low voltage main) mode	1 MHz to 4 MHz	Wide voltage mode

- Remarks 1.** Using both the wide voltage mode and full speed mode imposes no restrictions on writing, erasing, or verification.
- 2.** For details about communication commands, see **3.4.4 Communication commands**.

### 3.4.3 Selecting communication mode

Communication modes of the RL78 microcontroller are as follows.

**Table 3 – 6 Communication Modes**

Communication Mode	Standard Setting <sup>Note 1</sup>			Pins Used	
	Port	Speed <sup>Note 2</sup>	Frequency		Multiply Rate
1-line UART (when flash memory programmer is used, or when external device is used)	UART	115200 bps, 250000 bps, 500000 bps, 1 Mbps	—	—	TOOL0
Dedicated UART (when external device is used)	UART	115200 bps, 250000 bps, 500000 bps, 1 Mbps	—	—	TOOLTxD, TOOLRxD

**Notes 1.** Selection items for Standard settings on GUI of the flash memory programmer.

**2.** Because factors other than the baud rate error, such as the signal waveform slew, also affect UART communication, thoroughly evaluate the slew as well as the baud rate error.

### 3.4.4 Communication commands

The RL78 microcontroller executes serial programming through the commands listed in **Table 3 – 7**.

The signals sent from the dedicated flash memory programmer or external device to the RL78 microcontroller are called commands, and programming functions corresponding to the commands are executed. For details, refer to the **RL78 Microcontrollers (RL78 Protocol A) Programmer Edition Application Note (R01AN0815)**.

**Table 3 – 7 Flash Memory Control Commands**

Classification	Command Name	Function
Verify	Verify	Compares the contents of a specified area of the flash memory with data transmitted from the programmer.
Erase	Block Erase	Erases a specified area in the flash memory.
Blank check	Block Blank Check	Checks if a specified block in the flash memory has been correctly erased.
Write	Programming	Writes data to a specified area in the flash memory <sup>Note</sup> .
Getting information	Silicon Signature	Gets the RL78 microcontroller information (such as the part number, flash memory configuration, and programming firmware version).
	Checksum	Gets the checksum data for a specified area.
	Security Get	Gets security information.
	Security Release	Release setting of prohibition of writing.
Others	Reset	Used to detect synchronization status of communication.
	Baud Rate Set	Sets baud rate when UART communication mode is selected.

**Note** Confirm that no data has been written to the write area. Because data cannot be erased after block erase is prohibited, do not write data if the data has not been erased.

Product information (such as product name and firmware version) can be obtained by executing the “Silicon Signature” command.

**Table 3 – 8** is a list of signature data and **Table 3 – 9** shows an example of signature data.

**Table 3 – 8 Signature Data List**

Field Name	Description	Number of Transmit Data
Device code	The serial number assigned to the device	3 bytes
Device name	Device name (ASCII code)	10 bytes
Code flash memory area last address	Last address of code flash memory area (Sent from lower address. Example: 00000H to 3FFFFH (256 KB) → FFH, FFH, 03H)	3 bytes
Data flash memory area last address	Last address of data flash memory area (Sent from lower address. Example: F1000H to F2FFFH (8 KB) → FFH, 2FH, 0FH)	3 bytes
Firmware version	Version information of firmware for programming (Sent from upper address. Example: From Ver. 1.23 → 01H, 02H, 03H)	3 bytes

**Table 3 – 9 Example of Signature Data**

Field Name	Description	Number of Transmit Data	Data (Hexadecimal)
Device code	RL78 protocol A	3 bytes	10 00 06
Device name	R5F11AGJ	10 bytes	52 = “R” 35 = “5” 46 = “F” 31 = “1” 31 = “1” 41 = “A” 47 = “G” 4A = “J” 20 = “ ” 20 = “ ”
Code flash memory area last address	Code flash memory area 00000H to 3FFFFH (256 Kbytes)	3 bytes	FF FF 03
Data flash memory area last address	Data flash memory area F1000H to F2FFFH (8 Kbytes)	3 bytes	FF 2F 0F
Firmware version	Ver.1.23	3 bytes	01 02 03

### 3.5 Processing Time for Each Command When PG-FP6 Is in Use (Reference Value)

The following shows the processing time for each command (reference value) when PG-FP6 is used as a dedicated flash memory programmer.

**Table 3 – 10 Processing Time for Each Command When PG-FP6 Is in Use (Reference Value)**

PG-FP6 Command	256 Kbytes Code Flash
Erasing	2.5 s
Writing	5.5 s
Verification	5.5 s
Writing after erasing	8 s

**Remark** The command processing times (reference values) shown in the table are typical values under the following conditions.

Port: TOOL0 (single-line UART)

Speed: 1,000,000 bps

Mode: Full speed mode (flash operation mode: HS (high speed main) mode)

### 3.6 Self-Programming

The RL78 microcontroller supports a self-programming function that can be used to rewrite the code flash memory via a user program. Because this function allows a user application to rewrite the code flash memory by using the flash self-programming library, it can be used to upgrade the program in the field.

- Cautions**
1. The self-programming function cannot be used when the CPU operates with the subsystem clock.
  2. To prohibit an interrupt during self-programming, in the same way as in the normal operation mode, execute the self-programming library in the state where the IE flag is cleared (0) by the DI instruction. To enable an interrupt, clear (0) the interrupt mask flag to accept in the state where the IE flag is set (1) by the EI instruction, and then execute the self-programming library.
  3. The high-speed on-chip oscillator should be kept operating during self-programming. If it is kept stopping, the high-speed on-chip oscillator clock should be operated (HIOSTOP = 0). The self-programming library should be executed after 30  $\mu$ s have elapsed.

- Remarks**
1. For details of the self-programming function, refer to **RL78 Microcontroller Flash Self Programming Library Type01 User's Manual (R01AN0350)**.
  2. For details of the time required to execute self-programming, see the notes on use that accompany the flash self-programming library tool.

The self-programming function has two flash memory programming modes; wide voltage mode and full speed mode.

Specify the mode that corresponds to the flash operation mode specified in bits CMODE1 and CMODE0 in option byte 000C2H.

Specify the full speed mode when the HS (high speed main) mode is specified. Specify the wide voltage mode when the LS (low speed main) mode or LV (low voltage main) mode is specified.

If the argument `fsl_flash_voltage_u08` is 00H when the `FSL_Init` function of the flash self-programming library provided by Renesas Electronics is executed, full speed mode is specified. If the argument is other than 00H, the wide voltage mode is specified.

- Remark** Using both the wide voltage mode and full speed mode imposes no restrictions on writing, erasing, or verification.

3.6.1 Self-programming procedure

The following figure illustrates a flow for rewriting the code flash memory by using a flash self-programming library.

Figure 3 – 8 Flow of Self Programming (Rewriting Flash Memory)

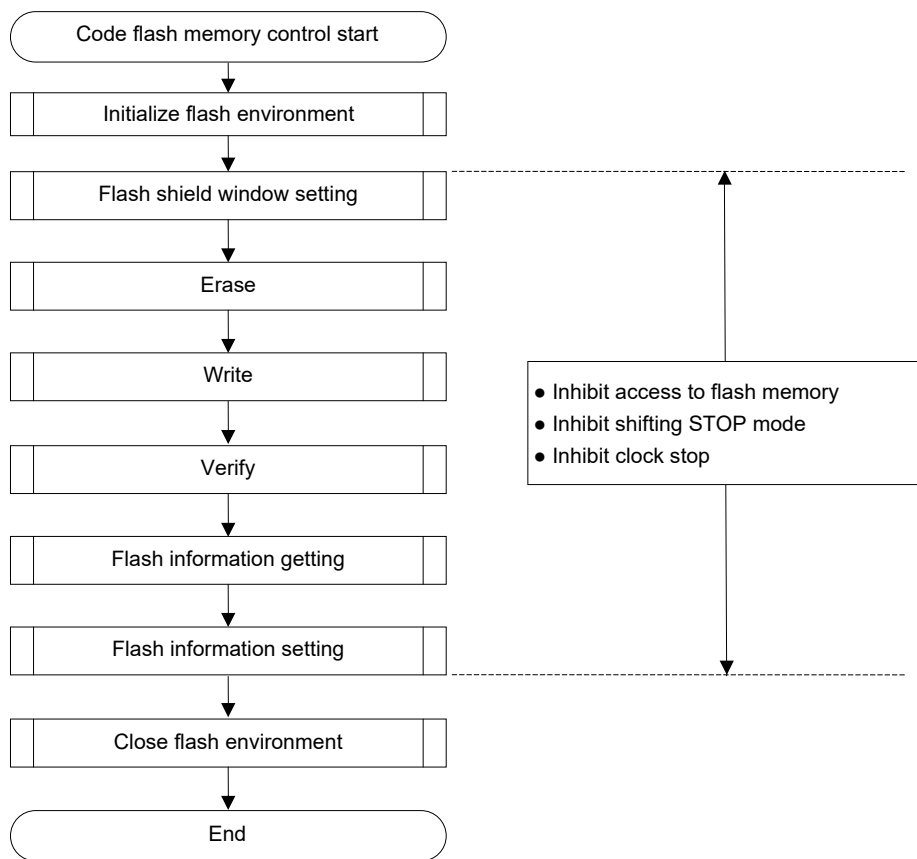

### 3.6.2 Boot swap function

If rewriting the boot area failed by temporary power failure or other reasons, restarting a program by resetting or overwriting is disabled due to data destruction in the boot area.

The boot swap function is used to avoid this problem.

Before erasing boot cluster 0<sup>Note</sup>, which is a boot area, by self-programming, write a new boot program to boot cluster 1 in advance. When the program has been correctly written to boot cluster 1, swap this boot cluster 1 and boot cluster 0 by using the set information function of the firmware of the RL78 microcontroller, so that boot cluster 1 is used as a boot area. After that, erase or write the original area, boot cluster 0.

As a result, even if a power failure occurs while the area is being rewritten, the program is executed correctly because it is booted from boot cluster 1 to be swapped when the program is reset and started next.

**Note** A boot cluster is a 4 Kbytes area and boot clusters 0 and 1 are swapped by the boot swap function.

**Figure 3 – 9 Boot Swap Function**

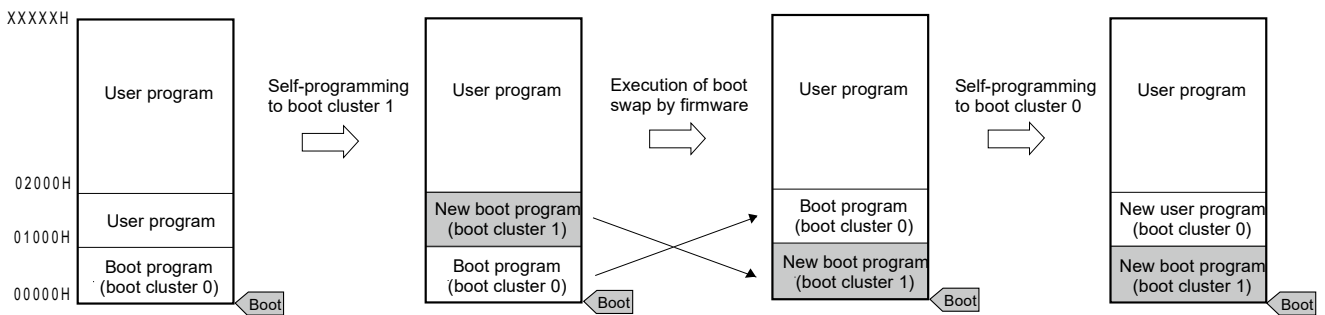

In an example of above figure, it is as follows.

Boot cluster 0: Boot area before boot swap

Boot cluster 1: Boot area after boot swap



Figure 3 – 10 Example of Executing Boot Swapping

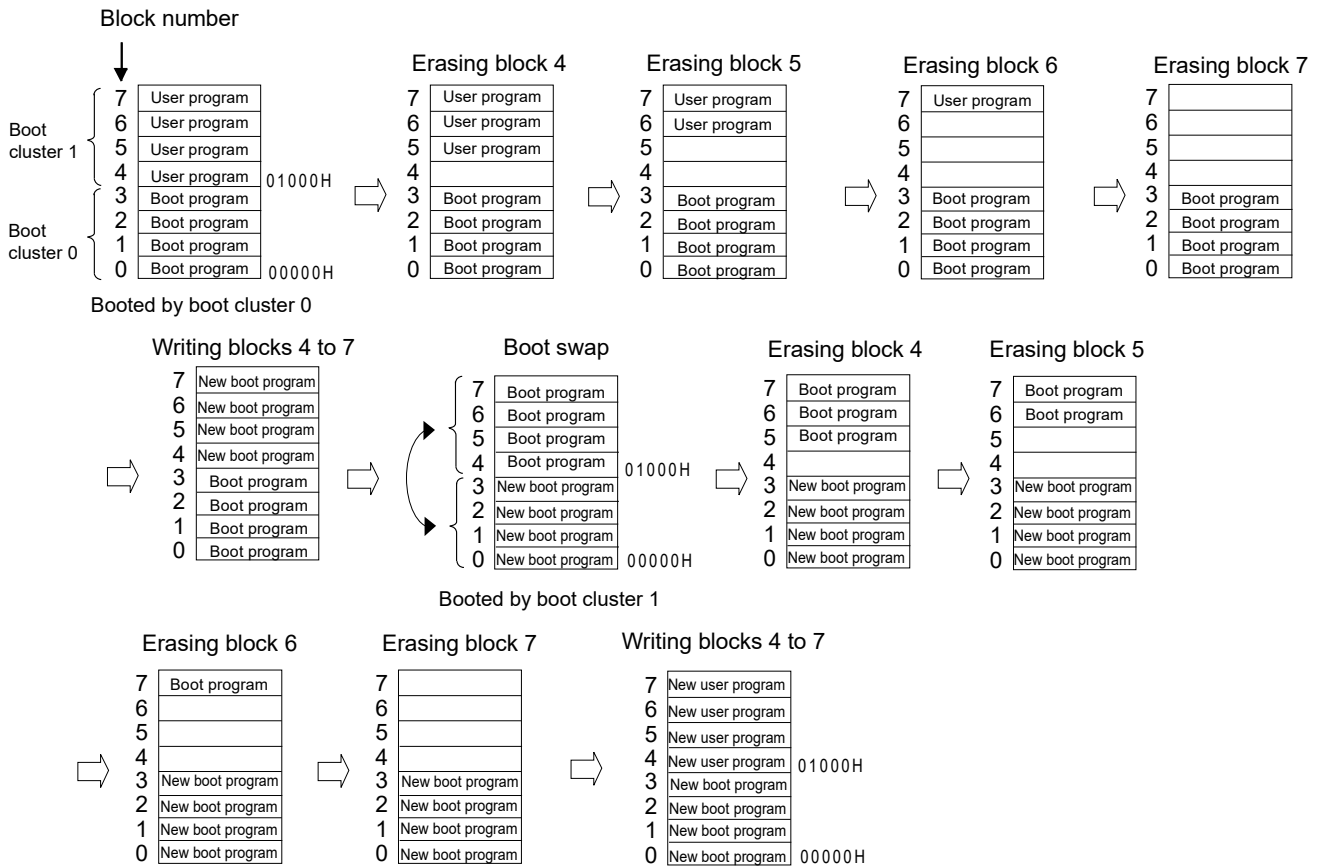

### 3.6.3 Flash shield window function

The flash shield window function is provided as one of the security functions for self-programming. It disables writing to and erasing areas outside the range specified as a window only during self-programming.

The window range can be set by specifying the start and end blocks. The window range can be set or changed during both serial programming and self-programming.

Writing to and erasing areas outside the window range are disabled during self-programming. During serial programming, however, areas outside the range specified as a window can be written and erased.

**Figure 3 – 11 Flash Shield Window Setting Example  
(Start Block: 04H, End Block: 06H)**

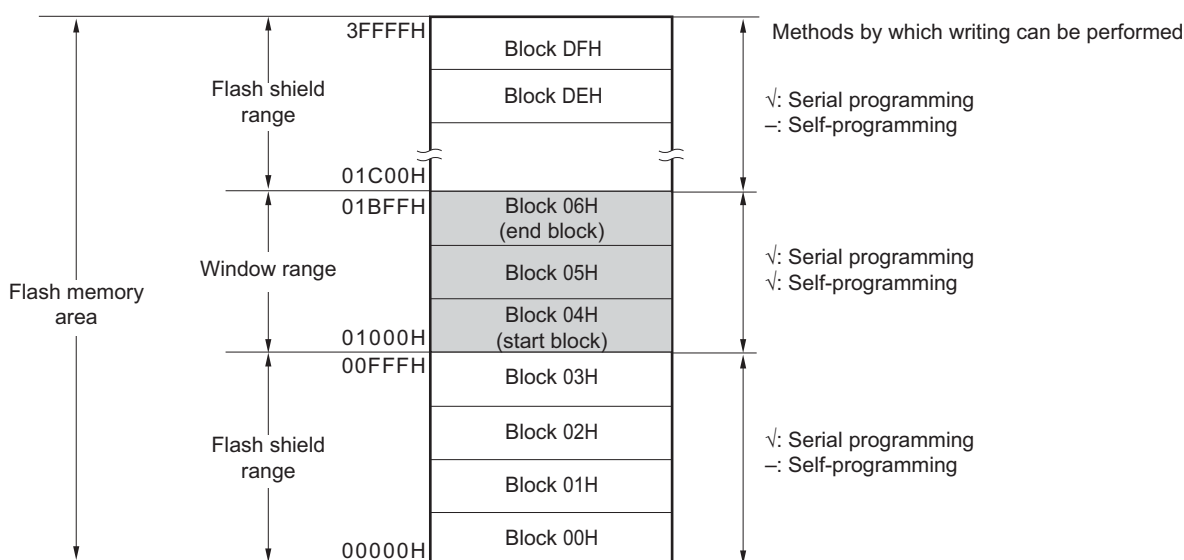

- Cautions**
1. If the rewrite-prohibited area of the boot cluster 0 overlaps with the flash shield window range, prohibition to rewrite the boot cluster 0 takes priority.
  2. The flash shield window can only be used for the code flash memory (and is not supported for the data flash memory).

**Table 3 – 11 Relationship Between Flash Shield Window Function Setting/Change Methods and Commands**

Programming Conditions	Window Range Setting/Change Methods	Execution Commands	
		Block Erase	Write
Self-programming	Specify the starting and ending blocks by the flash self-programming library.	Block erasing is enabled only within the window range.	Writing is enabled only within the range of window range.
Serial programming	Specify the starting and ending blocks on GUI of dedicated flash memory programmer, etc.	Block erasing is enabled also outside the window range.	Writing is enabled also outside the window range.

**Remark** See 3.7 Security Settings to prohibit writing/erasing during serial programming.

### 3.7 Security Settings

The RL78 microcontroller supports a security function that prohibits rewriting the user program written to the internal flash memory, so that the program cannot be changed by an unauthorized person.

The operations shown below can be performed using the Security Set command.

- Disabling block erase

Execution of the block erase command for a specific block in the flash memory is prohibited during serial programming. However, blocks can be erased by means of self-programming.

- Disabling write

Execution of the write command for entire blocks in the code flash memory is prohibited during serial programming. However, blocks can be written by means of self-programming.

After the setting of prohibition of writing is specified, releasing the setting by the Security Release command is enabled by a reset.

- Disabling rewriting boot cluster 0

Execution of the block erase command and write command on boot cluster 0 (00000H to 00FFFH) in the code flash memory is prohibited by this setting.

The block erase, write commands and rewriting boot cluster 0 are enabled by the default setting when the flash memory is shipped. Security can be set by serial programming and self-programming. Each security setting can be used in combination.

**Table 26-12** shows the relationship between the erase and write commands when the RL78 microcontroller security function is enabled.

**Caution** The security function of the dedicated flash programmer does not support self-programming.

**Remark** To prohibit writing and erasing during self-programming, use the flash shield window function (see 3.6.3 for detail).

Table 3 – 12 Relationship Between Enabling Security Function and Command

## (1) During serial programming

Valid Security	Executed Command	
	Block Erase	Write
Prohibition of block erase	Blocks cannot be erased.	Can be performed. <sup>Note</sup>
Prohibition of writing	Blocks can be erased.	Cannot be performed.
Prohibition of rewriting boot cluster 0	Boot cluster 0 cannot be erased.	Boot cluster 0 cannot be written.

**Note** Confirm that no data has been written to the write area. Because data cannot be erased after block erase is prohibited, do not write data if the data has not been erased.

## (2) During self-programming

Valid Security	Executed Command	
	Block Erase	Write
Prohibition of block erase	Blocks can be erased.	Can be performed.
Prohibition of writing		
Prohibition of rewriting boot cluster 0	Boot cluster 0 cannot be erased.	Boot cluster 0 cannot be written.

**Remark** To prohibit writing and erasing during self-programming, use the flash shield window function (see 3.6.3 for detail).

Table 3 – 13 Setting Security in Each Programming Mode

## (1) During serial programming

Security	Security Setting	How to Disable Security Setting
Prohibition of block erase	Set via GUI of dedicated flash memory programmer, etc.	Cannot be disabled after set.
Prohibition of writing		Set via GUI of dedicated flash memory programmer, etc.
Prohibition of rewriting boot cluster 0		Cannot be disabled after set.

**Caution** Releasing the setting of prohibition of writing is enabled only when the security is not set as the block erase prohibition and the boot cluster 0 rewrite prohibition with code flash memory area and data flash memory area being blanks.

## (2) During self-programming

Security	Security Setting	How to Disable Security Setting
Prohibition of block erase	Set by using flash self-programming library.	Cannot be disabled after set.
Prohibition of writing		Cannot be disabled during self-programming (set via GUI of dedicated flash memory programmer, etc. during serial programming).
Prohibition of rewriting boot cluster 0		Cannot be disabled after set.

## 3.8 Data Flash

### 3.8.1 Data flash overview

An overview of the data flash memory is provided below.

- The user program can rewrite the data flash memory by using the data flash library. For details, refer to **RL78 Family Data Flash Library User's Manual**.
- The data flash memory can also be rewritten through serial programming using the dedicated flash memory programmer or an external device.
- The data flash can be erased in 1-block (1-Kbyte) units.
- The data flash can be accessed only in 8-bit units.
- The data flash can be directly read by CPU instructions.
- Instructions can be executed from the code flash memory while rewriting the data flash memory (that is, background operation (BGO) is supported).
- Because the data flash memory is an area exclusively used for data, it cannot be used to execute instructions.
- Accessing the data flash memory is not possible while rewriting the code flash memory (during self-programming).
- Manipulating the DFLCTL register is not possible while rewriting the data flash memory.
- Transition to the STOP mode is not possible while rewriting the data flash memory.

- Cautions**
1. **The data flash memory is stopped after a reset is canceled. The data flash control register (DFLCTL) must be set up in order to use the data flash memory.**
  2. **The high-speed on-chip oscillator should be kept operating during data flash rewrite. If it is kept stopping, the high-speed on-chip oscillator clock should be operated (HIOSTOP = 0). The data flash library should be executed after 30  $\mu$ s have elapsed.**

**Remark** For rewriting the code flash memory via a user program, see 3.6 **Self-Programming**.

### 3.8.2 Register controlling data flash memory

#### (1) Data flash control register (DFLCTL)

This register is used to enable or disable accessing to the data flash.

The DFLCTL register is set by a 1-bit or 8-bit memory manipulation instruction.

Reset input sets this register to 00H.

Address: F0090H    After reset: 00H    R/W

Symbol	7	6	5	4	3	2	1	<0>
DFLCTL	0	0	0	0	0	0	0	DFLEN

DFLEN	Data flash access control
0	Disables data flash access
1	Enables data flash access

**Caution** Manipulating the DFLCTL register is not possible while rewriting the data flash memory.

### 3.8.3 Procedure for accessing data flash memory

The data flash memory is stopped after a reset ends. To access the data flash, make initial settings according to the following procedure.

- <1> Set bit 0 (DFLEN) of the data flash control register (DFLCTL) to 1.
- <2> Wait for the setup to finish for software timer, etc.  
The time setup takes differs for each flash operation mode for the main clock.  
<Setup time for each flash operation mode>
  - HS (High speed main): 5  $\mu$ s
  - LS (Low speed main): 720 ns
  - LV (Low voltage main): 10  $\mu$ s
- <3> After the wait, the data flash memory can be accessed.

- Cautions**
1. Accessing the data flash memory is not possible during the setup time.
  2. Transition to the STOP mode is not possible during the setup time. To enter the STOP mode during the setup time, clear DFLEN to 0 and then execute the STOP instruction.
  3. The high-speed on-chip oscillator should be kept operating during data flash rewrite. If it is kept stopping, the high-speed on-chip oscillator clock should be operated (HIOSTOP = 0). The flash data library should be executed after 30  $\mu$ s have elapsed.

After initialized, the data flash memory can be read by using a CPU instruction or can be read/written by using a data flash library.

If the DMA controller operates when the data flash memory is accessed, however, follow one of these procedures:

- (A) Suspending/forcibly terminating DMA transfer  
Before reading the data flash memory, suspend DMA transfer of all the channels used.  
After setting the DWAITn bit to 1, however, wait at least for the duration of three clocks ( $f_{CLK}$ ) before reading the data flash memory. After reading the data flash memory, lift the suspension of transfer by clearing the DWAITn bit to 0.  
Or, forcibly terminate DMA transfer in accordance with the procedure in **17.5.5 Forced termination by software** of the RL78/G1D User's Manual: Hardware before reading the data flash memory. Resume DMA transfer after the data flash memory has been read.
- (B) Access the data flash memory  
Access the data flash memory by using the newest data flash library.
- (C) Insertion of NOP  
Insert an NOP instruction immediately before the instruction that reads the data flash memory.

**<Example>**

```
MOVW    HL,!addr16    ; Reads RAM.
NOP                                ; Insert NOP instruction before reading data flash memory.
MOV     A,[DE]        ; Read data flash memory.
```

If a high-level language such as C is used, however, the compiler may generate two instructions for one code. In this case, the NOP instruction is not inserted immediately before the data flash memory read instruction. Therefore, read the data flash memory by (A) or (B) above.

- Remarks**
1. n: DMA channel number (n = 0, 1)
  2.  $f_{CLK}$ : CPU/peripheral hardware clock frequency

## CHAPTER 4 ELECTRICAL SPECIFICATIONS

This chapter describes the differences in specifications from the RL78/G1D.

For details on the specifications, the description of which is omitted from this user's manual, see the RL78/G1D User's Manual: Hardware (R01UH0515E).

### 4.1 Absolute Maximum Ratings

Parameter	Symbol	Condition	Rating	Unit
Supply voltage	$V_{DD}$		-0.5 to +4.0	V
Operating ambient temperature	$T_A$		-25 to +75	°C
Storage temperature	$T_{stg}$		-40 to +85	°C

### 4.2 Operating Voltage

Clock generator		Flash operation mode	Operation voltage	CPU operation frequency ( $f_{CLK}$ ) <sup>Note 1</sup>
Main system clock ( $f_{MAIN}$ )	High speed on-chip oscillator clock ( $f_{IH}$ )	HS (high-speed main) mode	$2.7 V \leq V_{DD} \leq 3.6 V$	1 to 32 MHz
			$2.4 V \leq V_{DD} \leq 2.7 V$	1 to 16 MHz
		LS (low-speed main) mode	$1.8 V \leq V_{DD} \leq 3.6 V$	1 to 8 MHz
		LV (low-voltage main) mode <sup>Note 2</sup>	$1.6 V \leq V_{DD} \leq 3.6 V$	1 to 4 MHz
Subsystem clock ( $f_{SUB}$ )	XT1 clock ( $f_{XT}$ )	-	$1.6 V \leq V_{DD} \leq 3.6 V$	32.768 kHz
	External subsystem clock ( $f_{EXT}$ ) <sup>Note 1</sup>	-	$1.6 V \leq V_{DD} \leq 3.6 V$	32.768 kHz

**Notes** 1. Indicates only permissible oscillator frequency ranges. Refer to AC characteristics for instruction execution times. Request evaluation by the manufacturer of the oscillator circuit mounted on a board to check the oscillator characteristics.

2. Use of this mode is prohibited in the case of using the DC-DC converter.

### 4.3 Oscillator Characteristics

This module does not support X1 oscillation. Use the high-speed on-chip oscillator clock.



## 4.4 RF Transceiver Characteristics

### 4.4.1 RF transmission characteristics

( $T_A = +25^\circ\text{C}$ ,  $V_{DD} = 3.0\text{ V}$ ,  $f = 2402$  to  $2480\text{ MHz}$ ,  $\text{GND} = 0\text{ V}$ )

Parameter	Symbol	Condition	MIN.	TYP.	MAX.	Unit
RF frequency range	$\text{RF}_{CF}$		2402		2480	MHz
Maximum transmitted output power	$\text{RF}_{POWER}$	RF low power mode		-15		dBm
		RF normal mode		0		dBm
		RF high performance mode		0		dBm
Frequency tolerance	$\text{RF}_{TXFERR}$	-25 to $+75^\circ\text{C}$	-50		+50	ppm

### 4.4.2 RF reception characteristics

( $T_A = +25^\circ\text{C}$ ,  $V_{DD} = 3.0\text{ V}$ ,  $f = 2402$  to  $2480\text{ MHz}$ ,  $\text{GND} = 0\text{ V}$ )

Parameter	Symbol	Condition	MIN.	TYP.	MAX.	Unit	
RF frequency range	$\text{RF}_{CF}$		2402		2480	MHz	
Maximum input level	$\text{RF}_{LEVEL}$	$\text{PER} \leq 30.8\%$		0		dBm	
Receiver sensitivity	$\text{RF}_{STY}$	$\text{PER} \leq 30.8\%$ ideal	RF low power mode		-60		dBm
			RF normal mode		-90		dBm
			RF high performance mode		-92		dBm
		$\text{PER} \leq 30.8\%$ dirty	RF normal mode			-70	dBm

CHAPTER 5 PACKAGE RELATED INFORMATION

5.1 Module Drawings

JEITA Package Code	RENESAS Code	Previous Code	MASS [Typ.]
-	MLZZ0042ZA-A	—	0.357 g

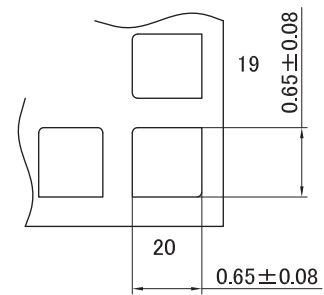
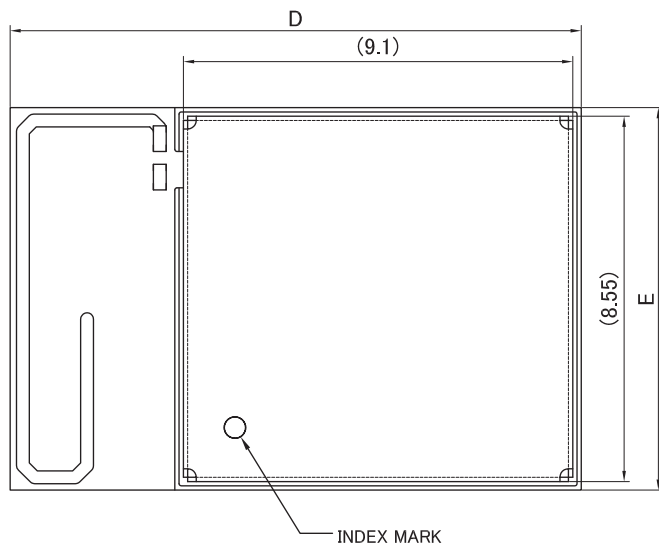

Detail F

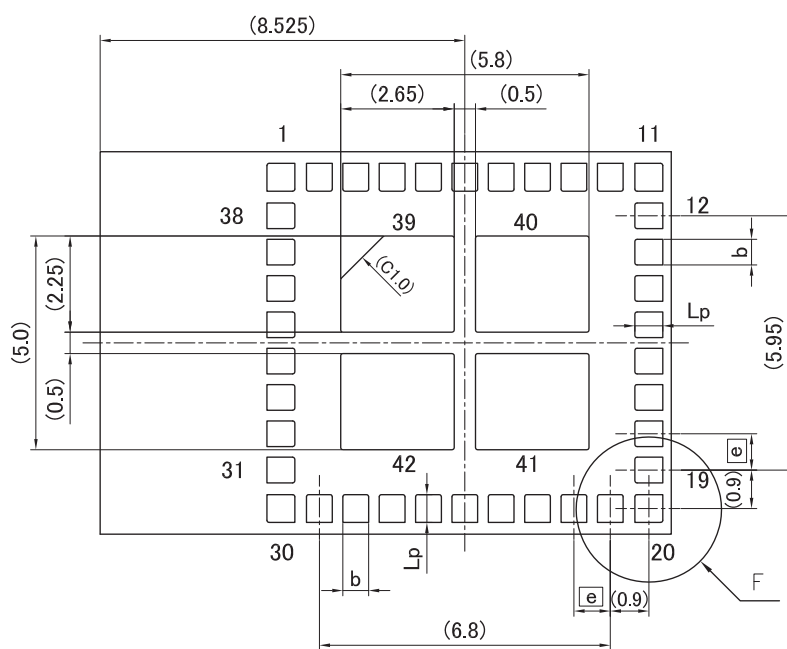
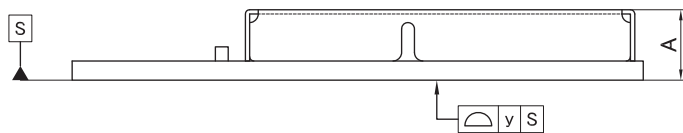

Reference Symbol	Dimension in Millimeters		
	Min	Nom	Max
D	13.20	13.35	13.50
E	8.80	8.95	9.10
A	—	—	1.7
e	—	0.85	—
Lp	0.57	0.65	0.73
b	0.52	0.6	0.68
y	—	—	0.1

5.2 Marking

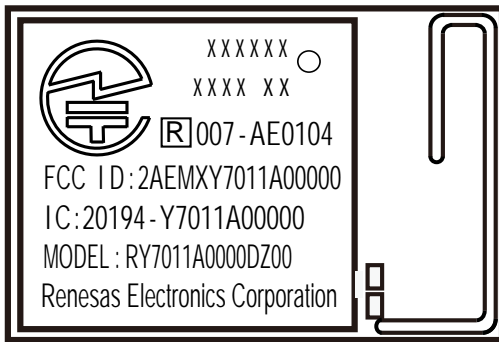

5.3 Foot Pattern (Top View: For Reference)

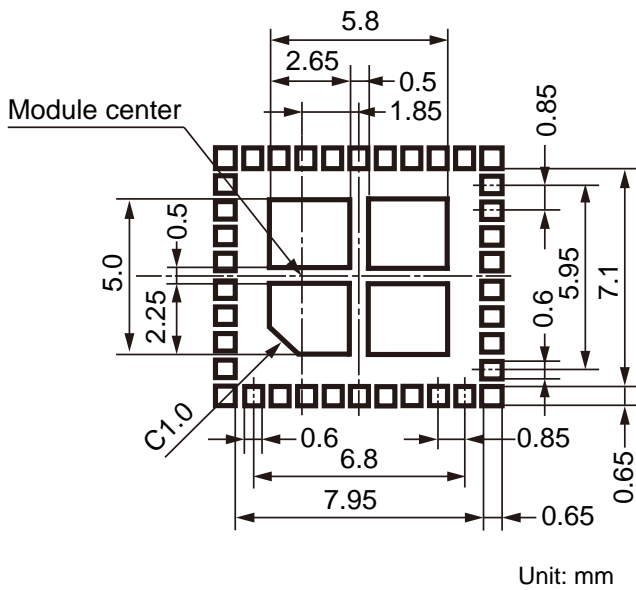

CHAPTER 6 EXAMPLES OF APPLICATION CIRCUITS

Figure 6 – 1 shows example of connecting to a host MCU, when the module is operated by software for verifying operation written to ship.

Figure 6 – 1 Operation by Software for Verifying Operation Written to Ship

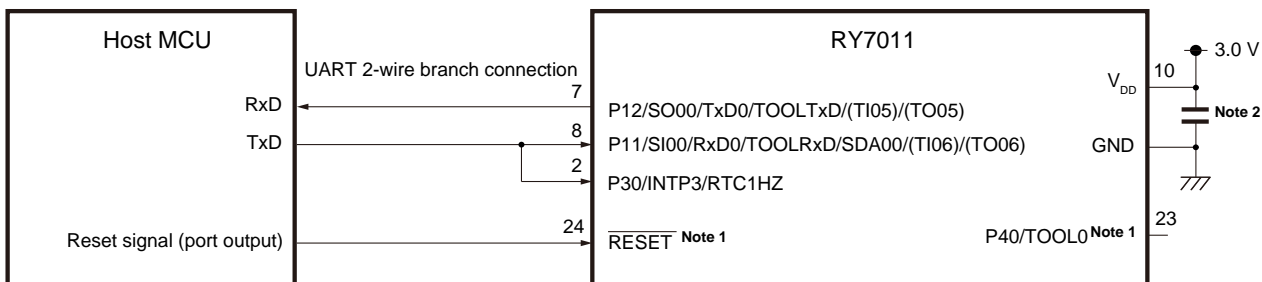

- Note 1.**  $\overline{\text{RESET}}$  and P40/TOOL0 pins are pulled-up/puledl-down with a resistor in accordance with the system requirement (see RL78/G1D User’s Manual: Hardware).
- 2.** Insert bypass capacitor of several  $\mu\text{F}$  between the  $V_{\text{DD}}$  and GND pins to suit the characteristics the power supply and wiring patterns.

Figure 6 – 2 to figure 6 – 6 show examples of application circuits.

Figure 6 – 2 UART Operation (2-wire Branch Connection: default) : Supply of the RF Slow Clock Signal from the Host MCU to This Module<sup>Notes 1, 2, 3</sup>

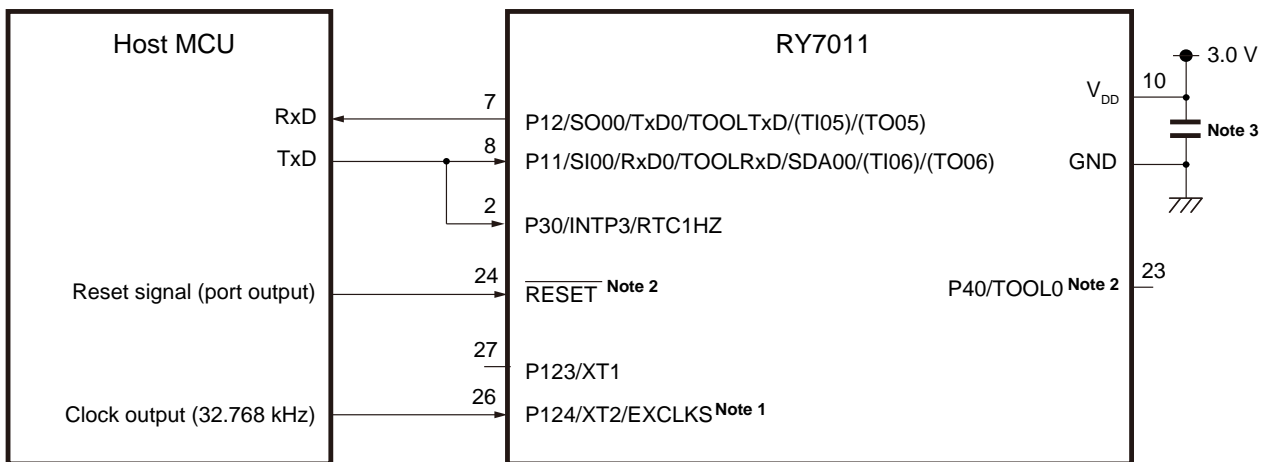

- Notes 1.** Accuracy of the frequency should be no greater than  $\pm 250$  ppm.
- 2.** Add an appropriate resistor (pull-up or pull-down) to be connected to the  $\overline{\text{RESET}}$  and P40/TOOL0 pins as required (see the RL78/G1D User’s Manual: Hardware).
- 3.** Insert a bypass capacitor of several  $\mu\text{F}$  between the  $V_{\text{DD}}$  and GND pins to suit the characteristics of the power supply and wiring patterns.

**Figure 6 – 3 CSI Operation (5-wire Connection) : Supply of the RF Slow Clock Signal from the Host MCU to This Module**<sup>Notes 1, 2, 3</sup>

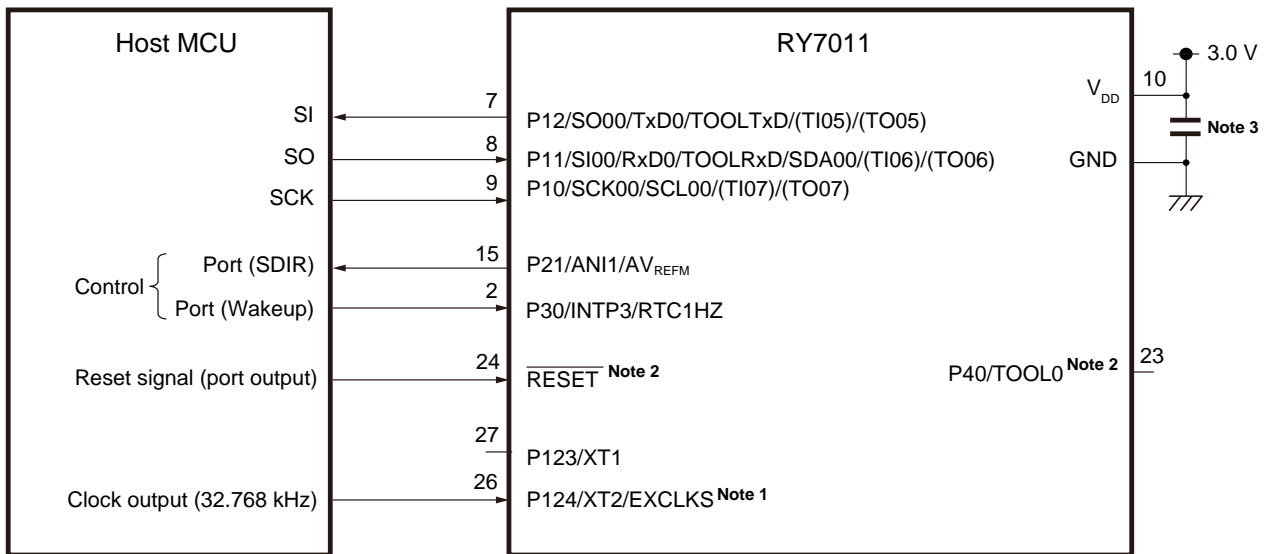

- Notes**
1. Accuracy of the frequency should be no greater than  $\pm 250$  ppm.
  2. Add an appropriate resistor (pull-up or pull-down) to be connected to the  $\overline{\text{RESET}}$  and P40/TOOL0 pins as required (see the RL78/G1D User's Manual: Hardware).
  3. Insert a bypass capacitor of several  $\mu\text{F}$  between the V<sub>DD</sub> and GND pins to suit the characteristics of the power supply and wiring patterns.

**Figure 6 – 4 I<sup>2</sup>C Operation (3-wire Connection: default) : Supply of the RF Slow Clock Signal from the Host MCU to This Module**<sup>Notes 1, 2, 3</sup>

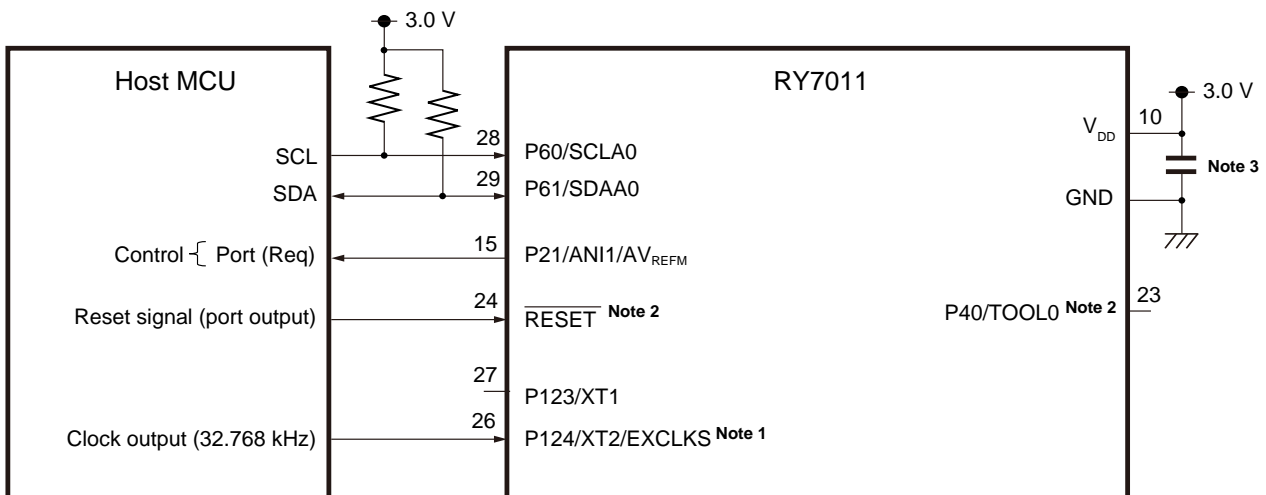

- Notes**
1. Accuracy of the frequency should be no greater than  $\pm 250$  ppm.
  2. Add an appropriate resistor (pull-up or pull-down) to be connected to the  $\overline{\text{RESET}}$  and P40/TOOL0 pins as required (see the RL78/G1D User's Manual: Hardware).
  3. Insert a bypass capacitor of several  $\mu\text{F}$  between the V<sub>DD</sub> and GND pins to suit the characteristics of the power supply and wiring patterns.

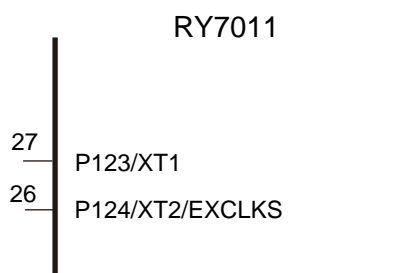
Figure 6 – 5 Connection of the XT1 and XT2/EXCLKS Pins When an On-Chip Oscillator Is in Use<sup>Note</sup>

**Note** For pins P123 and P124, see 2.2 Connection of Unused Pins.

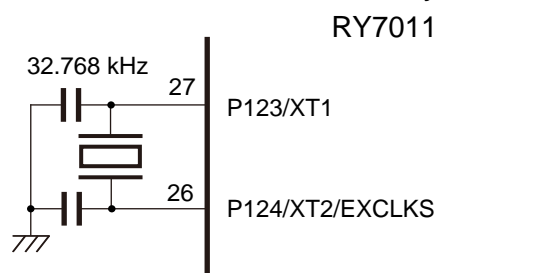
Figure 6 – 6 Connection of the XT1 and XT2/EXCLKS Pins When a Crystal Resonator Is Externally Connected<sup>Note</sup>

**Note** Request evaluation by the manufacturer of the oscillator circuit to check the crystal resonator characteristics.  
Verified : FC-12M (manufactured by Seiko Epson Corporation, product No. X1A000061000600)

**CHAPTER 7 SOLDERING CONDITION**

**7.1 Soldering Method**

Reflow

**7.2 Maximum Reflow Times**

Twice

**7.3 Recommended Temperature Profile**

Item	Condition
Maximum reflow temperature (package surface)	≤ 260 °C
Period over which the temperature is no lower than 255°C	≤ 30 s
Period over which the temperature is no lower than 217°C	60 to 150 s
Period over which the temperature remains at the preheat temperature (150 to 200°C)	60 to 120 s

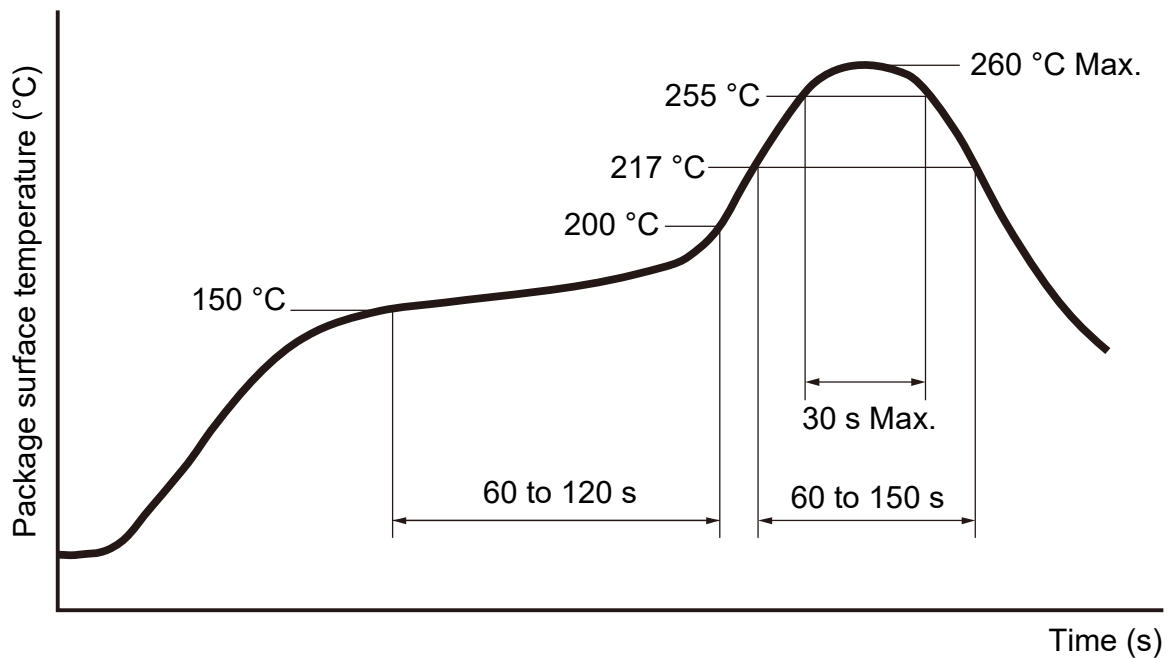

**CHAPTER 8 PACKAGING****8.1 Quantity of Components to Be Packaged**

RY7011A0000DZ00#001: 2500 pcs (per reel)

RY7011A0000DZ00#002: 100 pcs (per reel)



8.2 Carrier Tape and Reel Dimensions

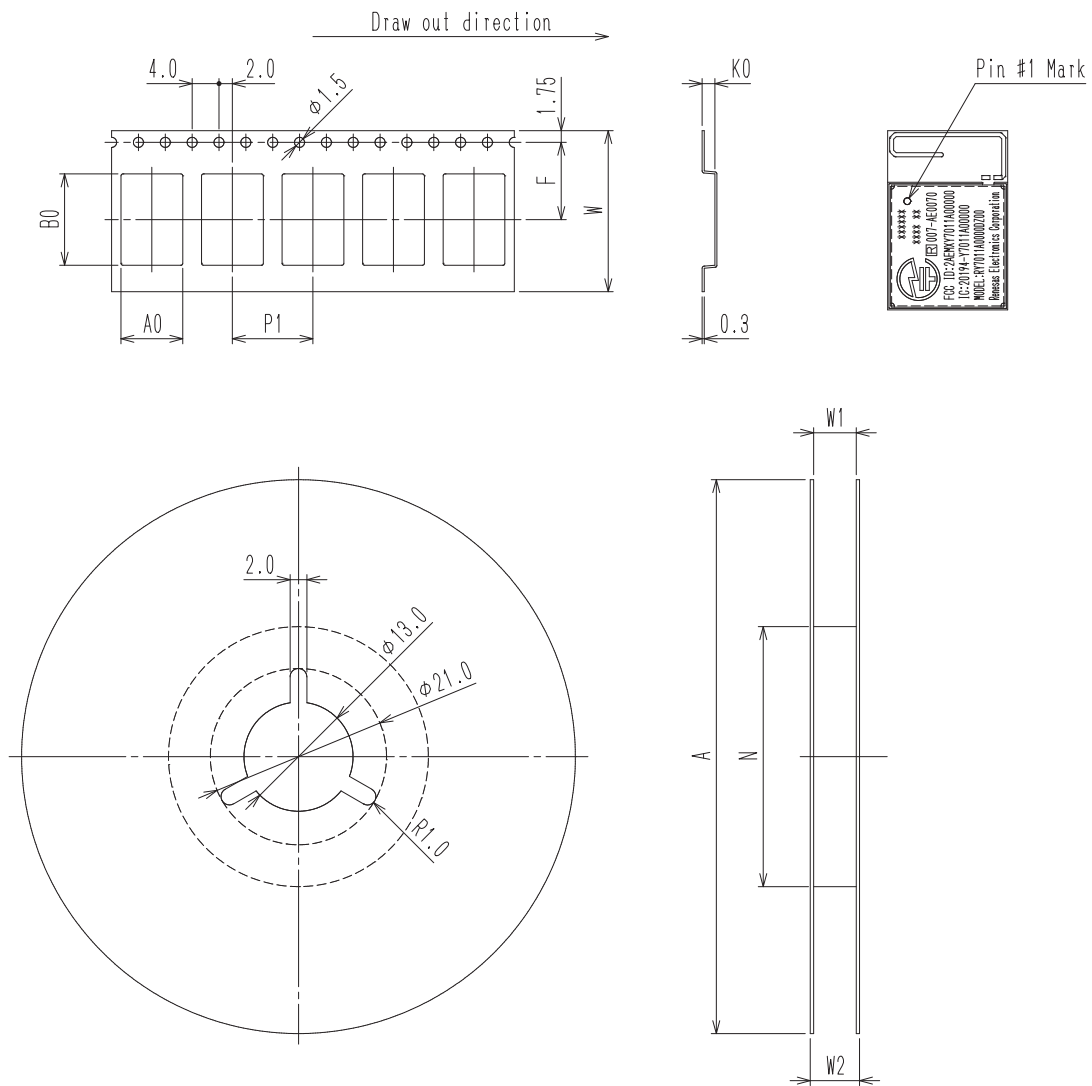

Tape Code		
Tape Dimensions (mm)	W	24.0
	P1	12.0
	A0	9.2
	B0	13.6
	K0	1.9
	F	11.5
Reel Dimensions (mm)	A	330.0
	N	80.0
	W1	25.4
	W2	29.4
Maximum storage pcs. Module/Reel		2500
Material	Tape	Carbon PS
	Reel	Carbon PS
Surface resistance	Tape	$1.0 \times 10^5 \sim 1.0 \times 10^{11} \Omega/\square$
	Reel	$1.0 \times 10^5 \sim 1.0 \times 10^{11} \Omega/\square$

【Unit:mm】

### 8.3 Taping Direction

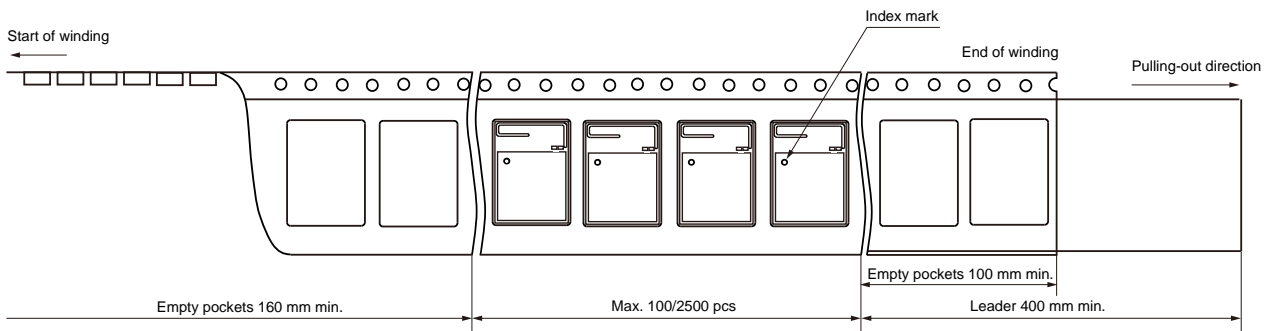

### 8.4 Peel Strength of Cover Tape

Peel strength: 0.1 to 1.3 N

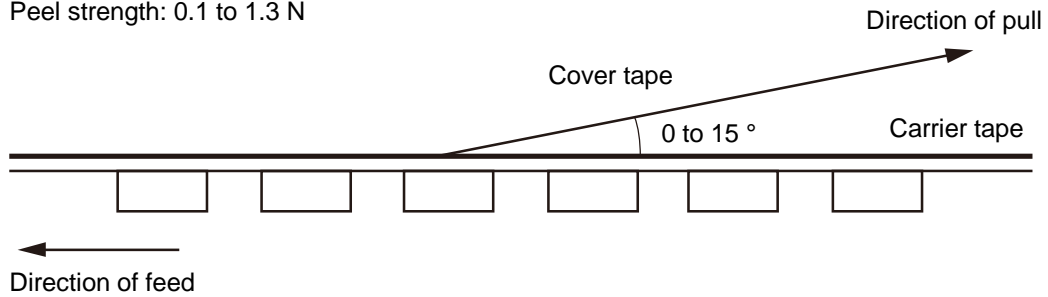

8.5 Packaging Specifications

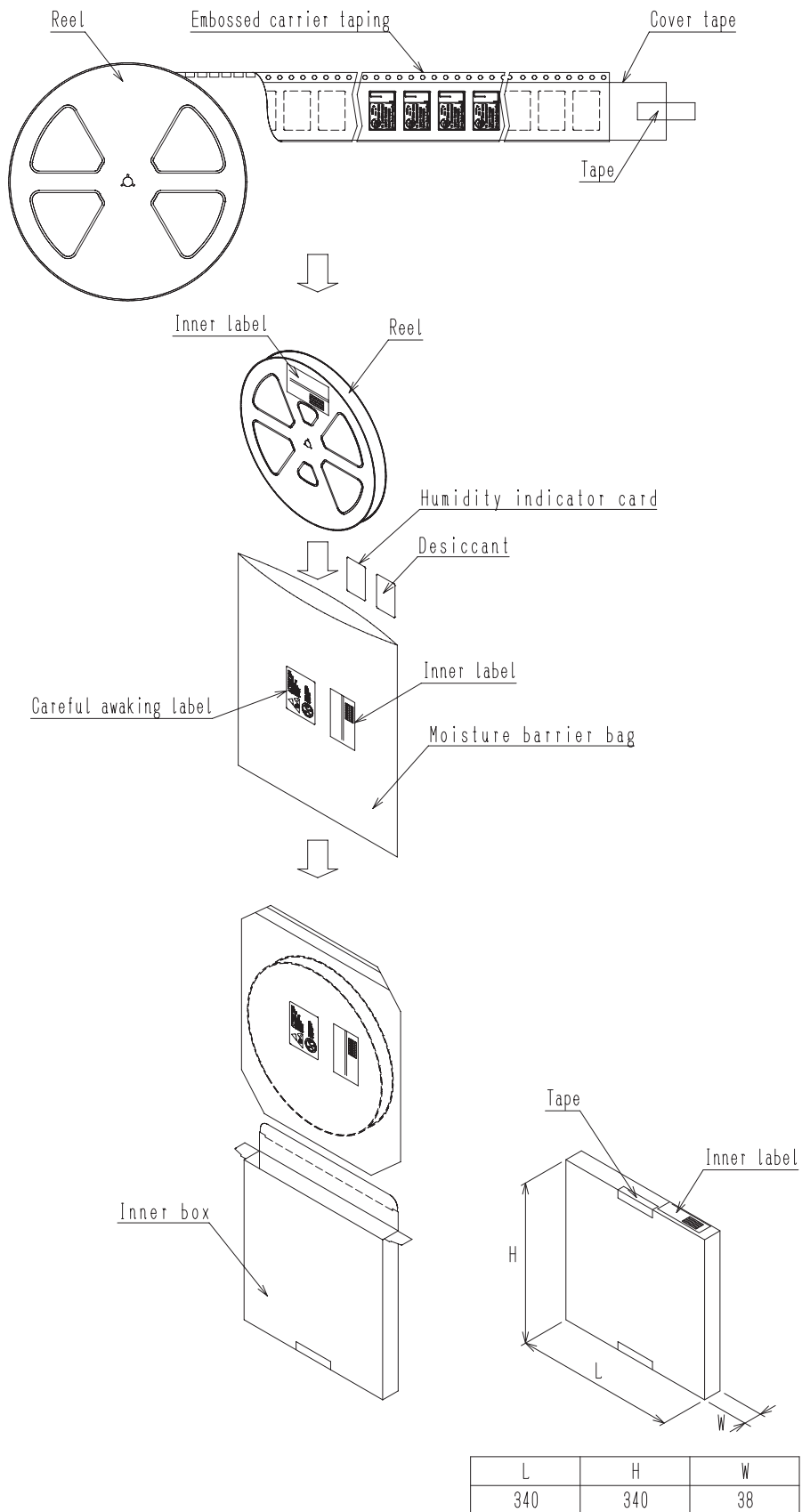

【Unit:mm】

## 8.6 Storage Conditions

Unopened state: We recommend storing packages at 5 to 35 °C and under humidity of up to 60 %, and using components within two years after the delivery.

After opening: Mount the components at 30 °C and under humidity of up to 60 % within 7 days after opening.

Once 7 days elapsed after opening, put a product through the baking process at 125 °C for 24 hours before mounting it.

## CHAPTER 9 CERTIFICATION OF COMPLIANCE

### 9.1 Radio-Related Laws

Japan: Type certification (authentication number: 007-AE0104)

North America: FCC (FCC ID: 2AEMXY7011A00000), IC (20194-Y7011A00000)

Europe: CE (RED)<sup>Note</sup>

**Note** Certificates of compliance with radio-related tests based on RED order.

User system is required the final certification tests and CE marking.

### 9.2 Bluetooth SIG Certification

QDID : 82194

Name : Renesas Bluetooth low energy Module

Model Number : RY7011A0000DZ00

Product Type : End Product

### 9.3 Labeling and Requirement for User Information

Following descriptions are precautions for implementation of this module to an end system.

Since this module is not sold to general end users directly, there is no user manual. For the details about this module, please refer to the specification sheet. This module should be installed in the host product according the installation manual.

The following statements must be described on the user manual of host device of this module;

#### Note to users in the United States of America

##### Caution:

Changes or modifications not expressly approved by the party responsible for compliance could void the user's authority to operate the equipment.

##### Declaration of Conformity

This device complies with part 15 of FCC Rules.

Operation is subject to the following two conditions:

- (1) This device may not cause harmful interference, and
- (2) This device must accept any interference received, including interference that may cause undesired operation.

#### Note to users in the United States of America and Canada

##### Note to users

It is strictly forbidden to use antenna except designated.

This equipment must not be co-located or operated in conjunction with any other antenna or transmitter.

**[For mobile equipment]**

This equipment complies with FCC/IC radiation exposure limits set forth for an uncontrolled environment and meets the FCC radio frequency (RF) Exposure Guidelines and RSS-102 of the IC radio frequency (RF) Exposure rules. This equipment has very low levels of RF energy that is deemed to comply without maximum permissive exposure evaluation (MPE).

**Note to users in Canada**

Cet équipement est conforme aux limites d'exposition aux rayonnements énoncées pour un environnement non contrôlé et respecte les règles des radioélectriques (RF) de la FCC lignes directrices d'exposition et d'exposition aux fréquences radioélectriques (RF) CNR-102 de l'IC. Cet équipement émet une énergie RF très faible qui est considérée comme conforme sans évaluation de l'exposition maximale autorisée (MPE).

**[For portable equipment]**

This equipment complies with FCC/IC radiation exposure limits set forth for an uncontrolled environment and meets the FCC radio frequency (RF) Exposure Guidelines and RSS-102 of the IC radio frequency (RF) Exposure rules. This equipment has very low levels of RF energy that is deemed to comply without testing of specific absorption rate(SAR).

**Note to users in Canada**

Cet équipement est conforme aux limites d'exposition aux rayonnements énoncées pour un environnement non contrôlé et respecte les règles des radioélectriques (RF) de la FCC lignes directrices d'exposition et d'exposition aux fréquences radioélectriques (RF) CNR-102 de l'IC. Cet équipement émet une énergie RF très faible qui est considérée comme conforme sans évaluation du débit d'absorption spécifique (DAS).

**Note to users in Canada**

This device complies with Industry Canada's licence-exempt RSSs.

Operation is subject to the following two conditions:

- (1) This device may not cause interference; and
- (2) This device must accept any interference, including interference that may cause undesired operation of the device.

**Remarque concernant les utilisateurs au Canada**

Le présent appareil est conforme aux CNR d'Industrie Canada applicables aux appareils radio exempts de licence.

L'exploitation est autorisée aux deux conditions suivantes :

- (1) l'appareil ne doit pas produire de brouillage, et
- (2) l'utilisateur de l'appareil doit accepter tout brouillage radioélectrique subi, même si le brouillage est susceptible d'en compromettre le fonctionnement.

**The following information must be indicated on the host device of this module;****[for FCC]**

Contains Transmitter Module FCC ID: 2AEMXY7011A00000

or

Contains FCC ID: 2AEMXY7011A00000

This device complies with part 15 of the FCC Rules. Operation is subject to the following two conditions: (1) This device may not cause harmful interference, and (2) this device must accept any interference received, including interference that may cause undesired operation.

**[for IC]**

Contains IC: 20194-Y7011A00000

**European Community Compliance Statement****Note:**

Hereby, Renesas Electronics Corporation, declares that this RY7011A0000DZ00 is in compliance with the essential requirements and other relevant provisions of Directive 2014/53/EC.

The full text of the EU declaration of conformity is shown from the next page.



&lt;R&gt;

**Renesas Electronics Corporation**

3-2-24, Toyosu, Koto-ku, Tokyo, 135-0061, Japan

## EU DECLARATION of CONFORMITY (DoC)

This declaration of conformity is issued under the sole responsibility of the manufacturer:

Name: Renesas Electronics Corporation  
 Address: 3-2-24 Toyosu, Koto-ku Tokyo 135-0061 Japan

We declare that the DoC is issued under our sole responsibility and belongs to the following product.

**Object of the declaration:**

Product Name	RL78/G1D Module
Model Name	RY7011A0000DZ00
Software Name	Bluetooth low energy protocol stack, Beacon stack
Software Ver.	Bluetooth low energy protocol stack is V1.10, V1.11, V1.20, and V1.21. Beacon stack is V1.00, V2.00, and V.2.10.
Accessories	N/A

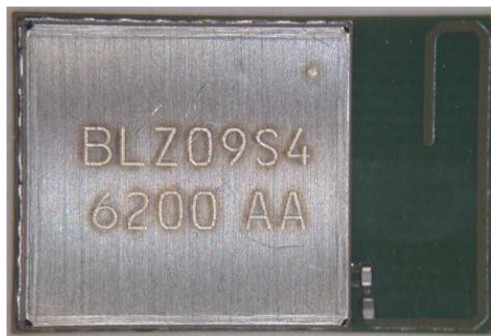

The object of the declaration described above is in conformity with the relevant Union harmonization legislation:

Radio Equipment (RE) Directive (2014/53/EU)



&lt;R&gt;

The following harmonized standards and technical specifications have been applied:

Health & Safety            EN 62368-1:2014(Second Edition)  
(Article 3.1(a)):            EN 62479: 2010

EMC                            EN 301 489-1 V2. 2. 3  
(Article 3.1(b)):            EN 301 489-17 V3. 2. 4

Radio Spectrum            EN 300 328 V2. 2. 2  
(Article 3.2):

Signed for and on behalf of:

Tokyo,  
Japan  
\_\_\_\_\_  
Place of Issue:

April 5, 2021  
\_\_\_\_\_  
Date of Issue:



\_\_\_\_\_  
Awanish Mishra  
Director  
IoT Platform Business Division  
IoT and Infrastructure Business Unit  
Renesas Electronics Corporation

## CHAPTER 10 NOTES ON LAYOUT

## 10.1 Main Board Design

To secure the antenna characteristics, take into account the following points to note in mounting this module on the main board.

Figure 10 – 1 Layout of the Main Board

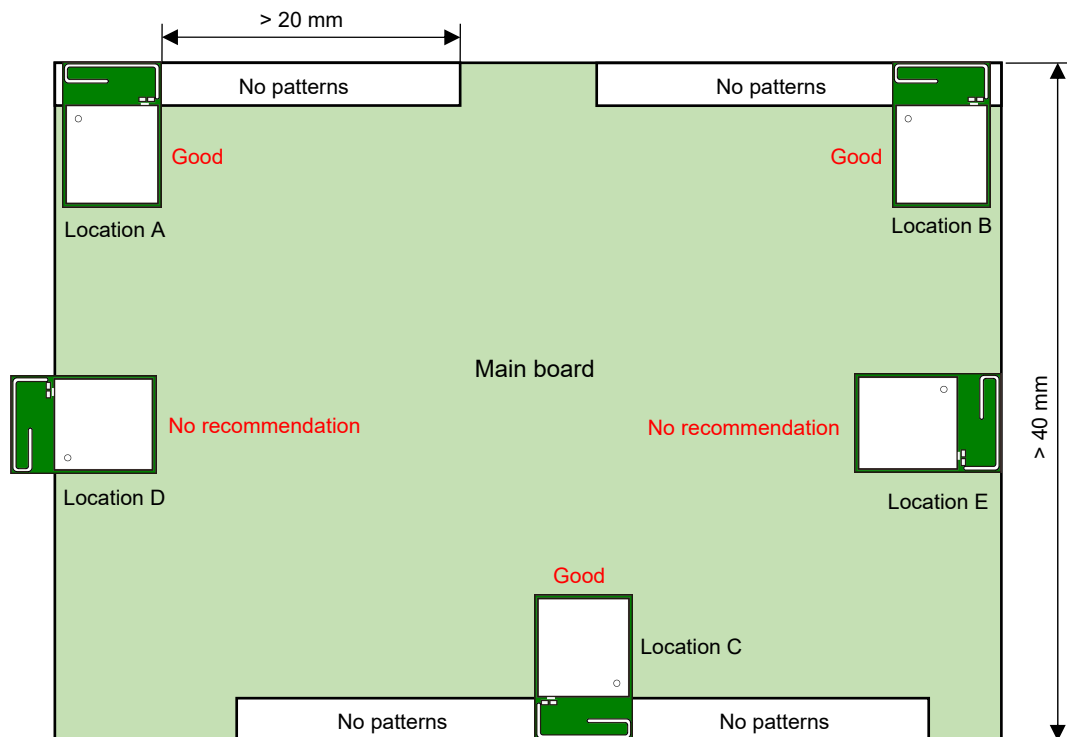

- Use a board which satisfies the conditions described below as the main board.

Material: FR4

Thickness: 1.0 to 1.6 mm

- Do not place patterns and a solid ground or power supply under the area where the module antenna is formed such as location E on the main board.
- Do not place patterns and conductors near the module antenna on the main board.

As a guideline, we recommend that any conductors have a separation of approximately at least 20 mm from the antenna, such as at locations A, B, and C in the figure.

Good antenna characteristics cannot be obtained if they are placed within 20 mm of the antenna.

- Place the main board under the area where the module antenna is formed.

The antenna has been adjusted on the assumption that the main board is under the area of the antenna. Good antenna characteristics cannot be obtained if the main board is not under the antenna.

We recommend not placing the module antenna beyond the edge of the board, as it is at location D in the figure.

- Make a solid ground to be included in the layer configuration of the main board as large as possible.

As a guideline, we recommend that the solid ground should extend for be approximately 40 mm, at least, in both directions.

If the ground area is smaller than 40-mm square, good antenna characteristics cannot be obtained.

## 10.2 Housing Design

To secure the antenna characteristics, take into account the following points to note in putting this module in a housing.

Figure 10 – 2 Distance from the Housing

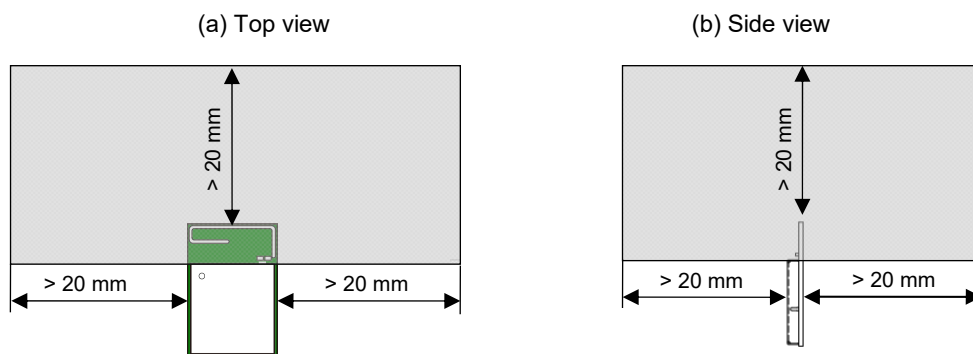

- Do not place metal conductors or components put in housings made of materials with high permittivity ( $\epsilon$ ) and high dielectric loss tangent ( $\tan\Delta$ ) near the module antenna.

Separate them by approximately 20 mm as a guide from the antenna.

- If the module antenna and housing are close to each other, use a material with a low permittivity ( $\epsilon$ ) and low dielectric loss tangent ( $\tan\Delta$ ) for the housing.

## 10.3 Layout of the Crystal Resonator for the External Subsystem Clock

Figure 10 – 3 External Crystal Resonator

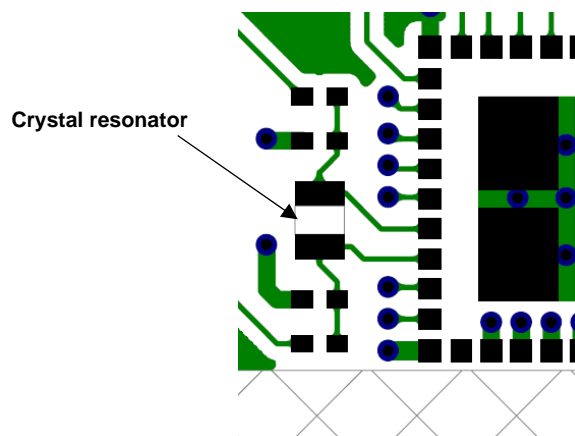

- If the crystal resonator is to be used for the external subsystem clock, connect the crystal resonator with the P123/XT1 and P124/XT2/EXCLKS pins such that the wiring between the resonator and these pins is as short as possible.

### 10.4 Handling of IC Pin

IC (Internally Connected) pin must be open without connection to any signal,  $V_{DD}$  or GND as **Figure 10 – 4**. However, it is acceptable to solder to a pad.

**Figure 10 – 4 Example of PCB Wiring**

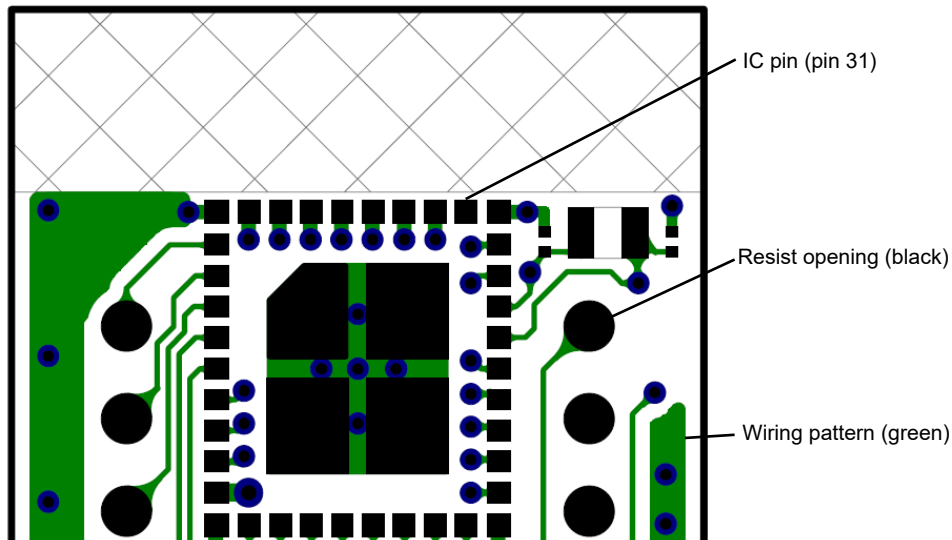

### 10.5 Designing the Power Supply System

Supply the power to the power supply pin ( $V_{DD}$ ) directly from a power supply which has little noise, such as a battery or low drop-out (LDO) regulator. When the power is supplied from a switching power supply, such as an external DC/DC converter, input the power externally or use the 32.768 kHz crystal oscillator. Do not use the on-chip oscillator for the RF slow clock.

Design the circuit such that the highest noise levels do not exceed 100 mV.

When a switching power supply such as an external DC/DC converter is in use with the RF slow clock (on-chip oscillator), apply one of the measures below.

1. Keep the switching frequency of the switching power supply to no more than 10 Hz or at 200 kHz or above.
2. Insert an LDO regulator between the switching power supply and the power supply pin ( $V_{DD}$ ) of the RF chip, making sure that this is in compliance with the recommended conditions of usage for the regulator.

**Caution** Switching power supplies produce periodic noise, so the device or system may require measures against noise if you are using one as the power supply. If this is the case, thoroughly confirm the operation of the device or system.

**APPENDIX A REVISION HISTORY****A.1 Major Revisions in This Edition**

Page	Description	Classification
CHAPTER 9 CERTIFICATION OF COMPLIANCE		
p.55, 56	Change of EU DECLARATION of CONFORMITY (DoC)	(b)

**Remark** "Classification" in the above table classifies revisions as follows.

(a): Error correction, (b): Addition/change of specifications, (c): Addition/change of description or note,

(d): Addition/change of package, part number, or management division, (e): Addition/change of related documents

## A.2 Revision History of Preceding Edition

(1/2)

Rev.	Description	Chapter
1.30	Change of Bluetooth version	CHAPTER 1 OUTLINE
	Changed flash memory programmers and added debugging emulators	CHAPTER 3 FLASH MEMORY
1.20	Change of 1.1 Features	CHAPTER 1 OUTLINE
	Change of 1.6 Outline of Functions	
	Addition of an item to 4.1 Absolute Maximum Ratings	CHAPTER 4 ELECTRICAL SPECIFICATIONS
	Change of Note in Figure 6 – 6 Connection of the XT1 and XT2/EXCLKS Pins When a Crystal Resonator Is Externally Connected	
	Change title of 8.3 Taping Direction of Components to Be Packaged	CHAPTER 8 PACKAGING
	Change of 9.1 Radio-Related Laws, and change title of 9.2 Bluetooth SIG Certification	CHAPTER 9 CERTIFICATION OF COMPLIANCE
	Addition of description to 9.3 Labeling and Requirement for User Information	
1.10	Change of Figure 10 – 1 Layout of the Main Board	CHAPTER 10 NOTES ON LAYOUT
	Change of description in 10.1 Main Board Design	
	Addition of 10.5 About Noise of Power Supply Pin	
1.01	Changed 1.3 Pin Configuration	CHAPTER 1 OUTLINE
	Changed 1.4 Pin Identification	
	Changed 1.5 Block Diagram	
	Changed 2.1 Pin Functions	CHAPTER 2 PIN FUNCTIONS
	Changed 2.2 Connection of Unused Pins	
	Changed 5.1 Module Drawings	CHAPTER 5 PACKAGE RELATED INFORMATION
	Changed 5.2 Marking	
	Figure 6 – 1 Operation by Software for Verifying Operation Written to Ship to Figure 6 – 4 I <sup>2</sup> C Operation	CHAPTER 6 EXAMPLES OF APPLICATION CIRCUITS
	Changed 9.1 Radio-Related Laws, and 9.2 Bluetooth SIG	CHAPTER 9 CERTIFICATION OF COMPLIANCE
	Changed 10.2 Housing Design	CHAPTER 10 NOTES ON LAYOUT
1.00	Changed 1.1 Features	CHAPTER 1 OUTLINE
	Changed Table 3 – 8 Signature Data List, and Table 3 – 9 Example of Signature Data	CHAPTER 3 FLASH MEMORY
	Changed 5.1 Module Drawings	CHAPTER 5 PACKAGE RELATED INFORMATION
	Changed 5.2 Marking	
	Changed 8.2 Carrier Tape and Reel Dimensions	CHAPTER 8 PACKAGING
	Changed 8.5 Packaging Specifications	
	Changed 9.1 Radio-Related Laws, and 9.2 Bluetooth SIG	CHAPTER 9 CERTIFICATION OF COMPLIANCE

(2/2)

Rev.	Description	Chapter
0.90	Changed the opening description	CHAPTER 1 OUTLINE
	Changed 1.1 Features	
	Added 1.2 Part Numbers	
	Changed 1.3 Pin Configuration (Top View)	
	Changed 1.6 Outline of Functions	
	Added description to 1.7 Differences from RL78/G1D	
	Changed 2.1 Pin Functions	CHAPTER 2 PIN FUNCTIONS
	Added 2.2 Connection of Unused Pins	
	Added the chapter	CHAPTER 3 FLASH MEMORY
	Changed 4.4 RF Transceiver Characteristics	CHAPTER 4 ELECTRICAL SPECIFICATIONS
	Changed the descriptions	CHAPTER 5 PACKAGE RELATED INFORMATION
	Changed the descriptions	CHAPTER 5 PACKAGE RELATED INFORMATION
	Added and changed the descriptions	CHAPTER 6 EXAMPLES OF APPLICATION CIRCUITS
	Changed 8.1 Minimum Quantity of Components to Be Packaged	CHAPTER 8 PACKAGING
Changed 8.6 Packaging Specifications		
Changed 9.1 Radio-Related Laws	CHAPTER 9 CERTIFICATION OF COMPLIANCE	
Added 10.4 Handling of IC Pin	CHAPTER 10 NOTES ON LAYOUT	
0.50	First edition issued.	Throughout

---

RL78/G1D Module (RY7011) User's Manual: Hardware

Publication Date: Rev. 0.50 Mar 11, 2016

Rev. 1.40 Apr 23, 2021

Published by: Renesas Electronics Corporation

---



RL78/G1D Module (RY7011)