

---

# RL78/L12+ISL97656+ISL6294

R01AN4065EC0110

Rev.1.10

## PM2.5 Monitor with Portable Battery

---

Mar. 31, 2019

### Introduction

This document describes an application for a PM2.5 Monitor with Portable Battery using Renesas microcontroller RL78/L12, integrated FET regulators ISL97656 and single cell battery chargers ISL6294.

### Target Device

RL78/L12, ISL97656, ISL6294

When applying the sample program covered in this application note to another microcomputer, modify the program according to the specifications for the target microcomputer and conduct an extensive evaluation of the modified program.

**Contents**

<b>1. Description .....</b>	<b>4</b>
1.1 Abstract.....	4
1.2 Specifications and Main Technical Parameters.....	4
<b>2. RL78/L12 Microcontroller .....</b>	<b>5</b>
2.1 RL78/L12 Block Diagram .....	5
2.2 Key Features.....	6
2.3 Pin Configuration .....	7
<b>3. System Outline .....</b>	<b>8</b>
3.1 Principle Introduction .....	8
3.2 Peripheral Functions to be Used .....	8
3.3 Pins to be Used .....	9
3.4 Operating Instructions.....	10
<b>4. Hardware.....</b>	<b>11</b>
4.1 PM2.5 Sensor Interface Circuit .....	12
4.2 EEPROM Driver Circuit.....	13
4.3 Battery Charge Circuit.....	14
4.4 Battery Discharge Boost Circuit.....	15
4.5 Battery Remaining Capacity Display Circuit.....	16
4.6 Air Quality Lights Display Circuit.....	17
4.7 LCD Interface Circuit .....	17
4.8 Alarm Circuit.....	18
4.9 Battery Voltage Detection Circuit.....	19
<b>5. Software .....</b>	<b>20</b>
5.1 Integrated Development Environment.....	20
5.2 Option Byte.....	20
5.3 Operation Outline.....	21
5.4 Flow Chart.....	23
5.4.1 Main Processing .....	23
5.4.2 Get EEPROM Data.....	24
5.4.3 Peripheral function Start.....	25
5.4.4 Battery processing .....	26
5.4.5 Air quality processing .....	27
5.4.6 Key processing .....	28
5.4.7 LCD Display .....	29
5.4.8 LED Display .....	30
5.4.9 Alarm processing.....	31
<b>6. Sample Code .....</b>	<b>32</b>

7. Reference Documents ..... 32

## 1. Description

### 1.1 Abstract

The PM2.5 Monitor with Portable Battery has two functions, one is PM2.5 concentration testing function, and the other is a portable charger which can provide emergency power for cell phones or other digital devices. It uses a lithium ion battery as its power storage unit and can either be charged or provide power.

The concept of “Portable Battery” is developed by the popularity of digital products, it is defined as a convenient and mobile battery. Endurance is vital for digital products as they are used more and more frequently. Then a portable battery can provide emergency power anytime, anywhere.

On the other hand, the impact of PM2.5 concentration in the air on the human health is a worldwide issue of concern. So, it’s necessary for us to know PM2.5 concentration value to guide our daily activities.

The PM2.5 Monitor with Portable Battery, which utilizes the RL78/L12 functions, integrates the above two functions into one product, with an LCD display as well.

### 1.2 Specifications and Main Technical Parameters

#### Technical Parameters

- Power supply: 5 V (2 lithium batteries)
- Low power consumption current (MCU): 0.1A (TYP.)
- Sensing method: Particles detection
- Alarm sound: About 80 dB
- Alarm interval: 1s/2s

#### Specifications

- Low power consumption function: After system powers on, it operates in low power consumption mode. When real-time clock interrupt occurs, system enters normal operation mode.
- Audible and visual alarm function: When the outside PM2.5 concentration value is larger than the pre-set value, the buzzer (about 80db) will sound at 1-sec intervals. When the battery is low, the buzzer (about 80db) will sound at 2-sec intervals.
- LED indication function:
  - Charge indicator:
    - If the battery is charging, the charge indicator light will stay on and the battery remaining indicator light will steadily blink. If the charging is completed, the charge indicator light will stay off and the battery remaining indicator will display normally.
  - Battery remaining indicator:
    - Different status of the 4 LED lights show the remaining battery amount.
- Operating temperature: -10°C ~ 60°C
- Operating humidity: 5 ~ 99% RH (No condensate water)

2. RL78/L12 Microcontroller

2.1 RL78/L12 Block Diagram

Figure 2.1 shows the block diagram of RL78/L12.



Figure 2.1 RL78/L12 Block Diagram

## 2.2 Key Features

- Minimum instruction execution time: Can be changed from high speed (0.04167  $\mu$ s @ 24 MHz operation with high-speed on-chip oscillator) to ultra-low speed (30.5  $\mu$ s @ 32.768 kHz operation with subsystem clock)
- General-purpose registers: (8-bit register  $\times$  8)  $\times$  4 banks
- ROM: 8 to 32 KB, RAM: 1 to 1.5 KB
- Selectable high-speed on-chip oscillator clock: 24/16/12/8/6/4/3/2/1 MHz (TYP.)
- On-chip single power supply flash memory
- On-chip debug function
- On-chip power-on-reset (POR) circuit
- On-chip watchdog timer (operable with the dedicated low-speed on-chip oscillator)
- On-chip key interrupt function
- On-chip clock output/buzzer output controller
- On-chip BCD (binary-coded decimal) correction circuit
- I/O port: 20 to 47 (N-ch open drain I/O [ $E_{V_{DD}}$  with stand voltage]:2)
- Timer
  - 16-bit timer: 8 channels
  - 12-bit interval timer: 1 channel
  - Real-time clock: 1 channel
- Serial interface
  - CSI: 2 channels
  - UART: 1 channel
  - Simplified I2C communication: 1 channel
- 8/10-bit resolution A/D converter: 4 to 10 channels
- Standby function: HALT mode, STOP mode, SNOOZE mode.
- Power supply voltage:  $V_{DD} = 2.0$  to 5.5 V
- Operating ambient temperature:  $T_A = -40$  to  $+85^{\circ}\text{C}$

RL78/L12 is widely used in small consumer electronics, including common technologies for industry, office, home appliance, healthcare, security and city application.

### 2.3 Pin Configuration

Figure 2.2 shows the pin configuration of RL78/L12.

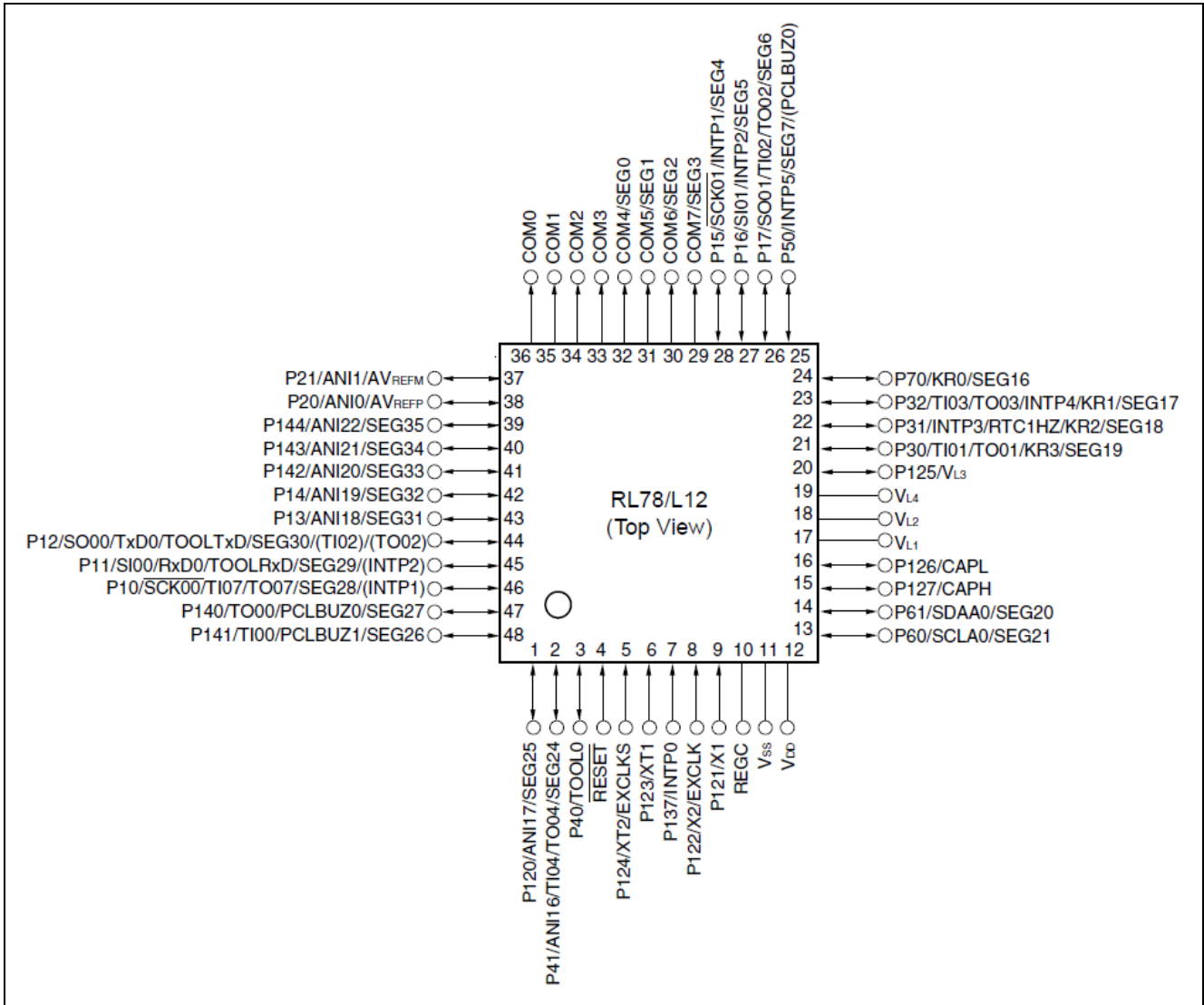

Figure 2.2 RL78/L12 Pin Configuration

### 3. System Outline

#### 3.1 Principle Introduction

IO ports, A/D converter, buzzer output controller, LCD controller and STOP mode function are used to achieve the PM2.5 Monitor with portable battery. The buzzer will sound if the PM2.5 concentration value is higher than the threshold value, which is set by users, or the battery voltage value is lower than 3.5 V.

Figure 3.1 shows the system block diagram for this application.

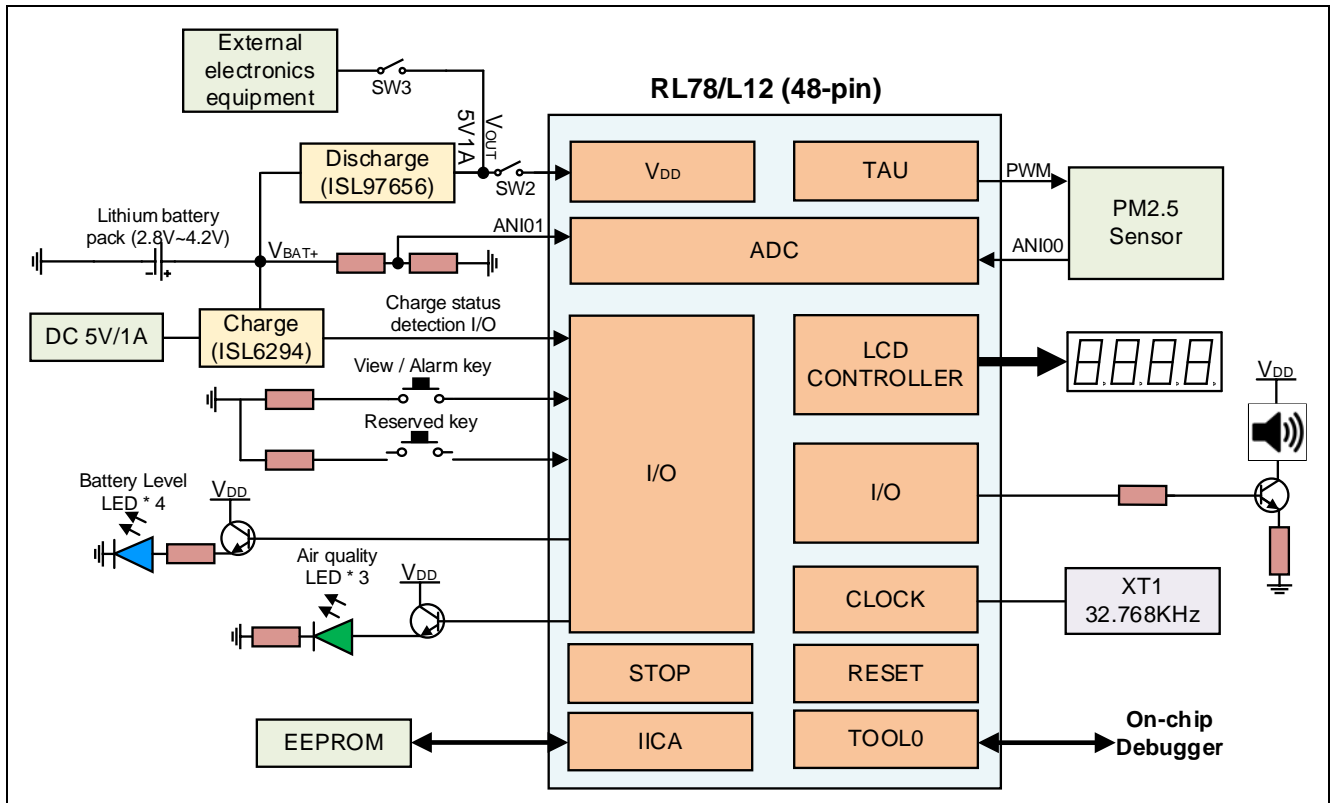

Figure 3.1 System Block Diagram

#### 3.2 Peripheral Functions to be Used

Table 3.1 lists the peripheral functions to be used and their usages.

Table 3.1 Peripheral Functions to be Used

Peripheral Function	Usage
Real-time Clock	Implement the real-time clock counting and generate the constant period interrupt (1s)
A/D converter	Measure the PM2.5 sensor output and measure the battery voltage.
Channel 0 and Channel 3 of TAU0	Output PWM wave output to the PM2.5 sensor
IICA0	Communication with EEPROM
LCD controller	Drive LCD display through automatic output of segment and common signals based on automatic display data register read



### 3.3 Pins to be Used

Table 3.2 lists the pins to be used and their descriptions.

**Table 3.2 Pins to be Used**

Pin Name	Description
P40/ TOOL0	On-chip debug
RESET	Hardware reset
P124/XT2	Clock supply for LCD driver module and Real-Time Clock
P123/XT1	
V <sub>SS</sub>	Ground
V <sub>DD</sub>	Power supply voltage
P61	Drive IICA0; read/write EEPROM
P60	
VL1, VL2, VL4	1/3 bias method, internal voltage boosting method
P126/CAPL, P127/CAPH	Connect a capacitor for the LCD
COM0-COM4, SEG0~SEG7	Control LCD
P137/INTP0	View/Alarm function switch input
P31/INTP3	Reserved switch input
P21/ANI1	Detect battery voltage
P20/ANI0	Detect sensor output voltage
P143	Control LED of the PM2.5 sensor
P70	Control buzzer
P14	CHG signal (ISL6294) input
P13	PPR signal (ISL6294) input
P144	Control the red LED
P30	Control the green LED
P10	Control the blue LED
P140	Control LEDs to display the battery capacity
P141	
P120	
P41	

### 3.4 Operating Instructions

SW2 is used to supply the power to the RL78/L12 MCU. SW3 is used to supply the power to the external device via USB interface.

- (1) Once turned on via SW2, the MCU resets and begins to read data from EEPROM.
- (2) After initialization operation, the MCU will enter STOP mode and wait for a real-time clock interrupt to wake the system up.
- (3) Once woken up, the MCU begins to measure the battery voltage and display the remaining capacity on the LEDs. The particle sensor is driven to detect current PM2.5 concentration. The MCU judges whether the concentration value exceeds the pre-set value and displays the PM2.5 concentration value on the LCD screen.
- (4) 4 blue LED lights are used to show current voltage percentage, and the colorful LED lights are used to display PM2.5 concentration value.
- (5) If the PM2.5 concentration value is larger than the pre-set value, the buzzer (about 80db) will sound at 1-sec intervals. If the battery voltage is low, the buzzer (about 80db) will sound at 2-sec intervals. If not, it will repeat (2) ~ (5).
- (6) Press the key of View/Alarm over 2s, the PM2.5 concentration value level can be set.
  - Level 0 (no alarm): PM2.5 concentration value is lower than 50  $\mu\text{g}/\text{m}^3$ .
  - Level 1: PM2.5 concentration value is bigger than 50  $\text{ug}/\text{m}^3$  and lower than 100  $\mu\text{g}/\text{m}^3$ .
  - Level 2: PM2.5 concentration value is bigger than 100  $\text{ug}/\text{m}^3$  and lower than 200  $\mu\text{g}/\text{m}^3$ .
  - Level 3: PM2.5 concentration value is bigger than 200  $\text{ug}/\text{m}^3$ .

### 4. Hardware

This section describes the circuits related to the MCU, including PM2.5 sensor interface circuit, EEPROM circuit, battery charge circuit, battery discharge boost circuit, battery remaining capacity display circuit, air quality lights display circuit, LCD interface circuit, alarm circuit and battery voltage detection circuit.

Figure 4.1 shows the board picture of the PM2.5 sensor interface circuit.

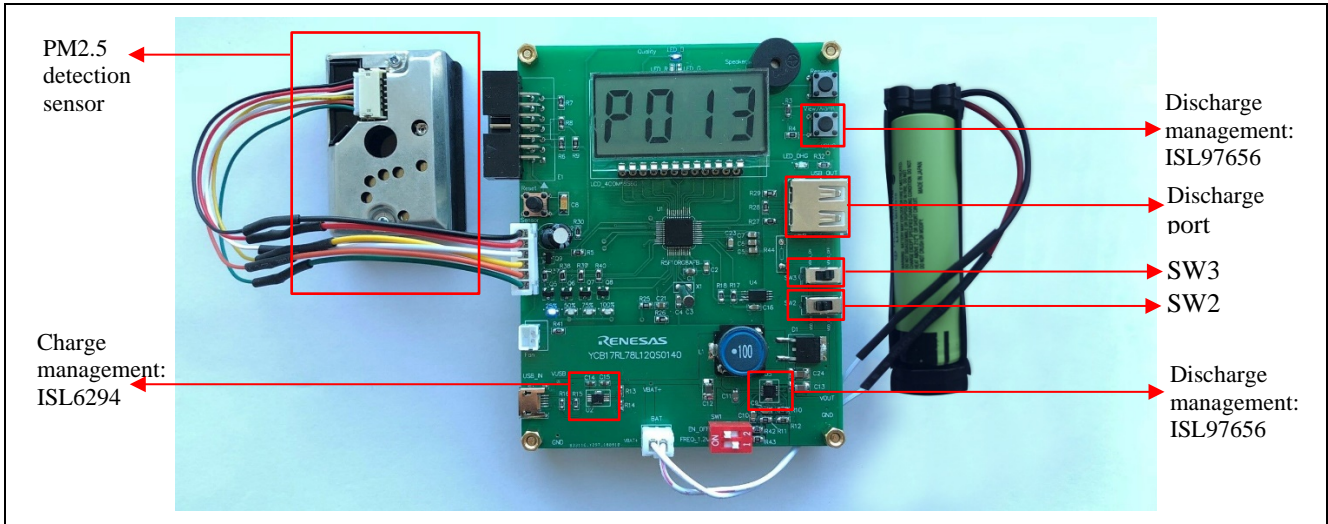
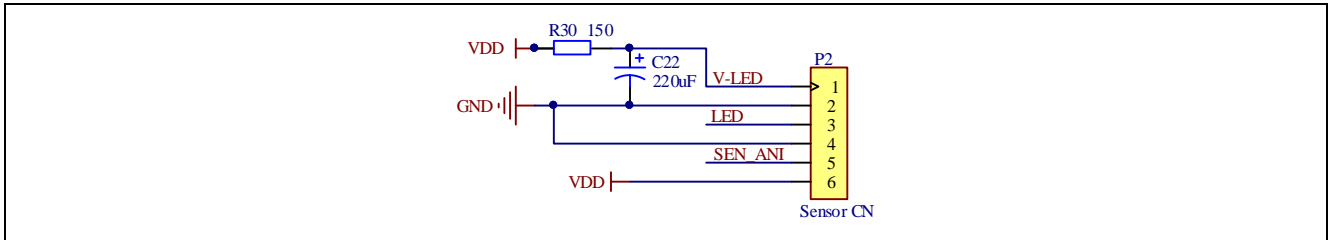

Figure 4.1 The Board Picture of the PM2.5 Sensor Interface Circuit

### 4.1 PM2.5 Sensor Interface Circuit

Figure 4.2 shows the schematic of the PM2.5 sensor interface circuit.



**Figure 4.2 PM2.5 Sensor Interface Circuit**

In this system, GP2Y1014 particle sensor is used to detect PM2.5 concentration.

An infrared emitting diode (IRED) and a phototransistor are diagonally arranged into this device to detect the reflected light of concentration in the air. It can detect particles larger than 0.8µm and outputs voltage signals.

After power-on, the system outputs PWM to drive the sensor and judges air quality according to voltage signals.

### 4.2 EEPROM Driver Circuit

Figure 4.3 shows the schematic of the EEPROM driver circuit.

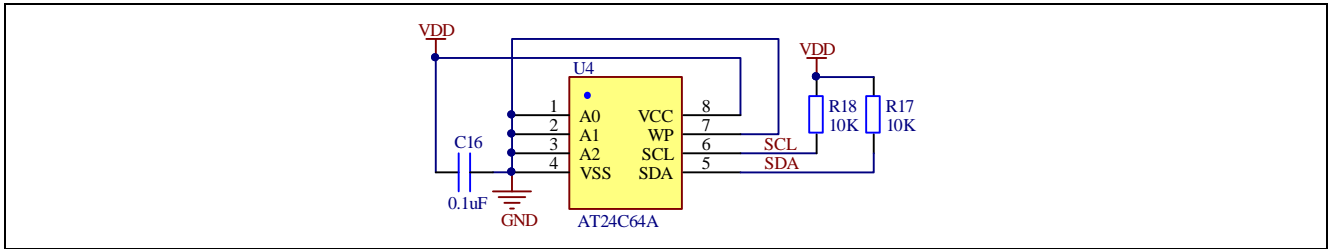

Figure 4.3 EEPROM Driver Circuit

AT24C64A (EEPROM memory device) is used to store the pre-set threshold value and daily/monthly PM2.5 concentration data. After power-on, data in the EEPROM is read and processed.

The EEPROM used in this application has a storage of 64K bit (8KB x 8bit), and it stores the following contents: Year (e.g. 17), Month (e.g. 01), Day (e.g. 01), Hour (e.g. 10), Minute (e.g. 00) and PM2.5 concentration. For further details please refer to table 4.1.

Table 4.1 EEPROM Storage and Endurance

Storing Interval	Memory Usage Per Day	Storage Endurance (64K bit Memory Full)
10 min (6 times/hour)	8 byte*24*6	1 week
1 h (once an hour)	8 byte*24	42 days and 16 hours

Note. If the data to be stored in your application is within 2K, RL78/L12 on-chip data flash is recommended other than EEPROM.

### 4.3 Battery Charge Circuit

Figure 4.4 shows the schematic of the battery charge circuit.

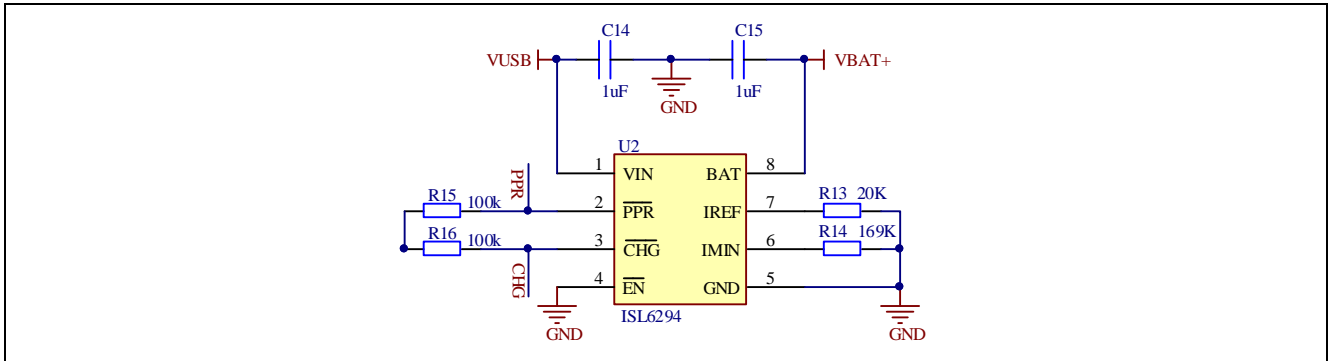

Figure 4.4 Battery Charge Circuit

ISL6294 is used as the charge management chip in this application. The entire charge cycle has 4 phases (including the trickle, constant-current, constant-voltage and charge maintenance), which can maximize electricity in the portable battery. The main MCU detects the charging status according to ISL6294's PPR pin and CHG pin, and then judge whether or not the charger is charging.

### 4.4 Battery Discharge Boost Circuit

Figure 4.5 shows the schematic of the battery discharge boost circuit.

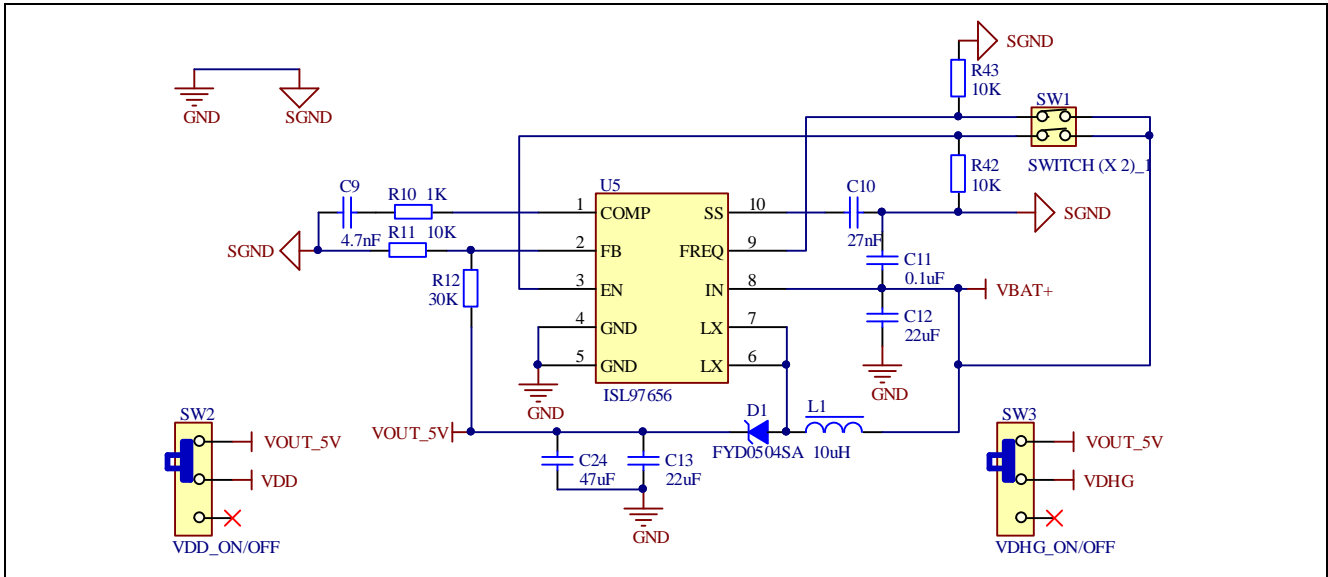

Figure 4.5 Battery Discharge Boost Circuit

ISL97656 is used as the battery discharge boost chip in this application. ISL97656 can deliver high output current at over 90% efficiency.

With an inductor, ISL97656 can be used as a DC-DC boost circuit which amplifies the battery voltage to a constant 5V/1A supplier and outputs to external devices.

SW2 is used to supply the power to the RL78/L12 MCU. SW3 is used to supply the power to the external device via USB interface.

### 4.5 Battery Remaining Capacity Display Circuit

Figure 4.6 shows the schematic of the battery remaining capacity display circuit.

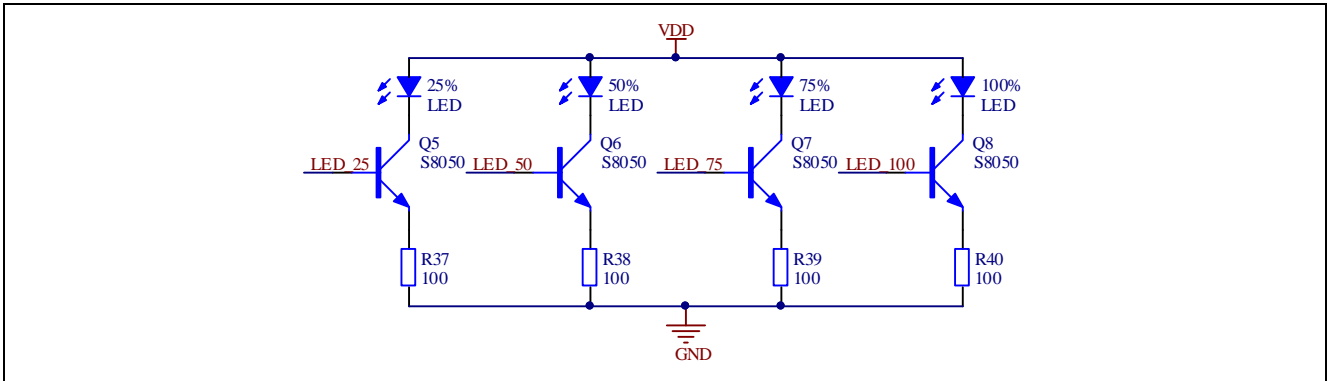

Figure 4.6 Battery Remaining Capacity Display Circuit

It displays the following percentages of the remaining battery power by combining 4 LED lights: 0%, 25%, 50%, 75%, 100%. For details see table 4.2.

Table 4.2 LED Display Combination

	LED_25	LED_50	LED_75	LED_100
Battery level: 0%	OFF	OFF	OFF	OFF
Battery level: 25%	ON	OFF	OFF	OFF
Battery level: 50%	ON	ON	OFF	OFF
Battery level: 75%	ON	ON	ON	OFF
Battery level: 100%	ON	ON	ON	ON



### 4.6 Air Quality Lights Display Circuit

Figure 4.7 shows the schematic of the air quality lights display circuit.

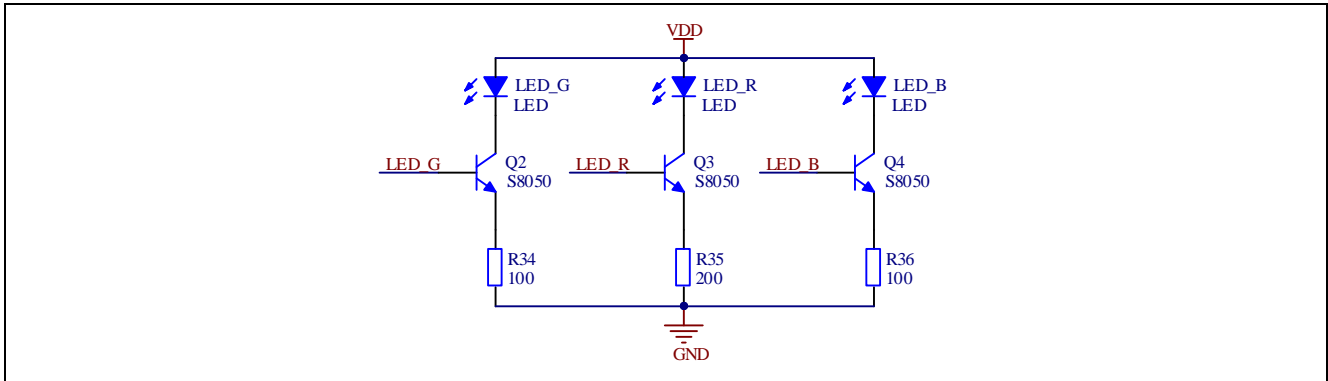

Figure 4.7 Air Quality Lights Display Circuit

It displays the air quality value by combining 3 LED lights. Please refer to Table 4.3 for details.

Table 4.3 LED Color Combination

	Red LED	Green LED	Blue LED
A (0-50)	OFF	OFF	ON
B (50-100)	OFF	ON	OFF
C (100-150)	ON	ON	OFF
E (>150)	ON	OFF	OFF

### 4.7 LCD Interface Circuit

Figure 4.8 shows the schematic of the LCD interface circuit.

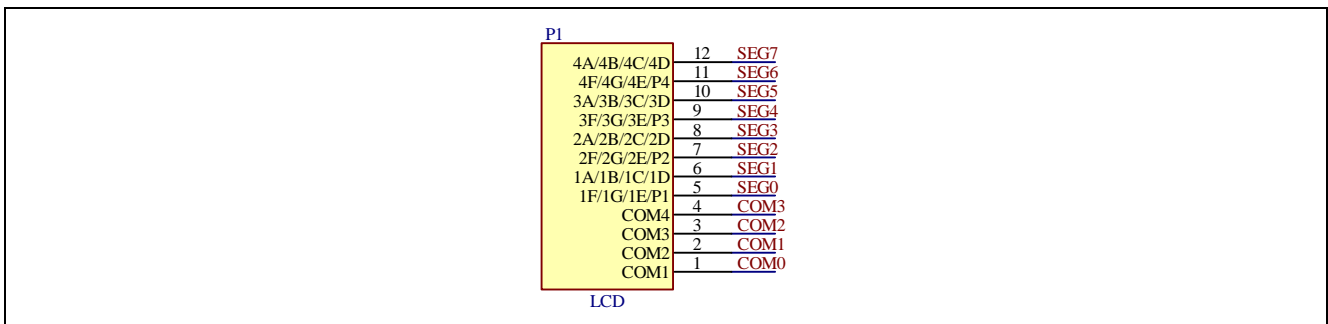

Figure 4.8 LCD Interface Circuit

The screen is a 4-digit 8-segment LCD display board and it is used to display current concentration value and the pre-set level of PM2.5. The RL78/L12 MCU can control LCD drivers by itself as it has 4 ~ 8 COM pins and 13 ~ 39 SEG pins.

### 4.8 Alarm Circuit

Figure 4.9 shows the schematic of the alarm circuit.

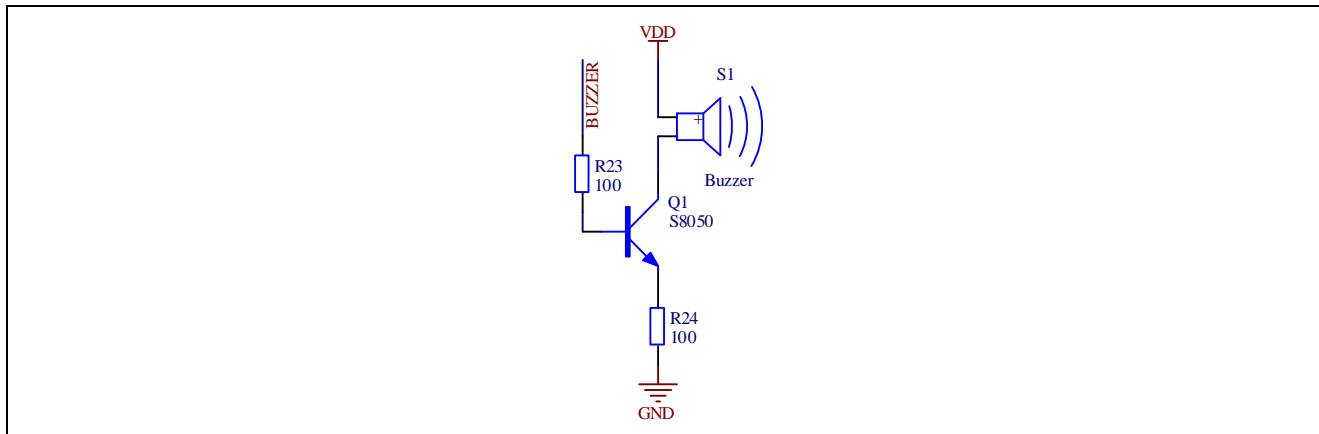
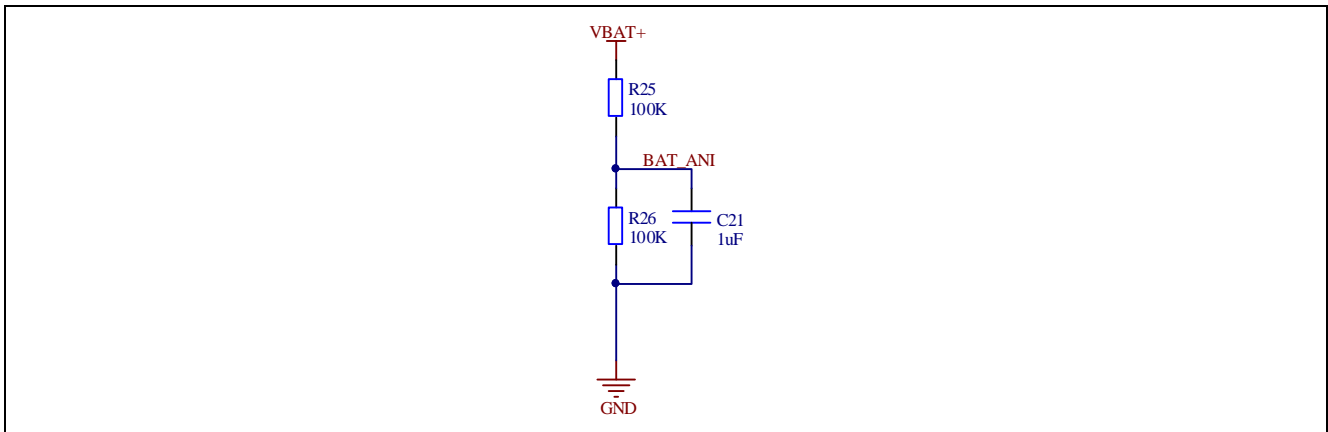

Figure 4.9 Alarm Circuit

If the outside PM2.5 concentration value is larger than the pre-set value, the buzzer (about 80db) will sound at 1-sec intervals. If the battery is low, the buzzer (about 80db) will sound at 2-sec intervals.

## 4.9 Battery Voltage Detection Circuit

Figure 4.10 shows the schematic of the battery voltage detection circuit.



**Figure 4.10 Battery Voltage Detection Circuit**

It uses the voltage divider circuit of 2 resistors to obtain current voltage value and then decides into which of the 4 grades the voltage value should be put.

## 5. Software

### 5.1 Integrated Development Environment

The sample code described in this chapter has been checked under the conditions listed in the table below.

**Table 5.1 Operation Check Conditions**

Item	Description
Microcontroller used	RL78/L12 (R5F10RG8)
Operating frequency	High-speed on-chip oscillator (HOCO) clock: 24 MHz CPU/peripheral hardware clock: 24 MHz
Operating voltage	5V (can run on a voltage range of 2.7 V to 5.5 V.) LVD detection voltage Rising edge 2.81V Falling edge 2.75V
Integrated development environment (CS+)	CS+ V6.00.00 from Renesas Electronics Corp.
C compiler (CS+)	CC-RL V1.05.00 from Renesas Electronics Corp.
Integrated development environment (e <sup>2</sup> studio)	e <sup>2</sup> studio V6.0.0 from Renesas Electronics Corp.
C compiler (e <sup>2</sup> studio)	CC-RL V1.05.00 from Renesas Electronics Corp.

### 5.2 Option Byte

Table 5.2 summarizes the settings of the option bytes.

**Table 5.2 Option Byte Settings**

Address	Value	Description
000C0H	11101111B	Stop watchdog timer operation. (Watchdog timer stops counting after reset)
000C1H	01111111B	LVD detection voltage Rising edge: 2.81V Falling edge: 2.75V
000C2H	11100000B	Operating frequency: 24 MHz (2.7 V ~ 5.5 V)
000C3H	10000100B	Enables the on-chip debugger.

### 5.3 Operation Outline

The tasks of the entire system are listed as below: peripheral initialization task, standby task, battery related operation, air quality related operation, display task and alarm task.

Figure 5.1 shows the block diagram for the tasks transition.

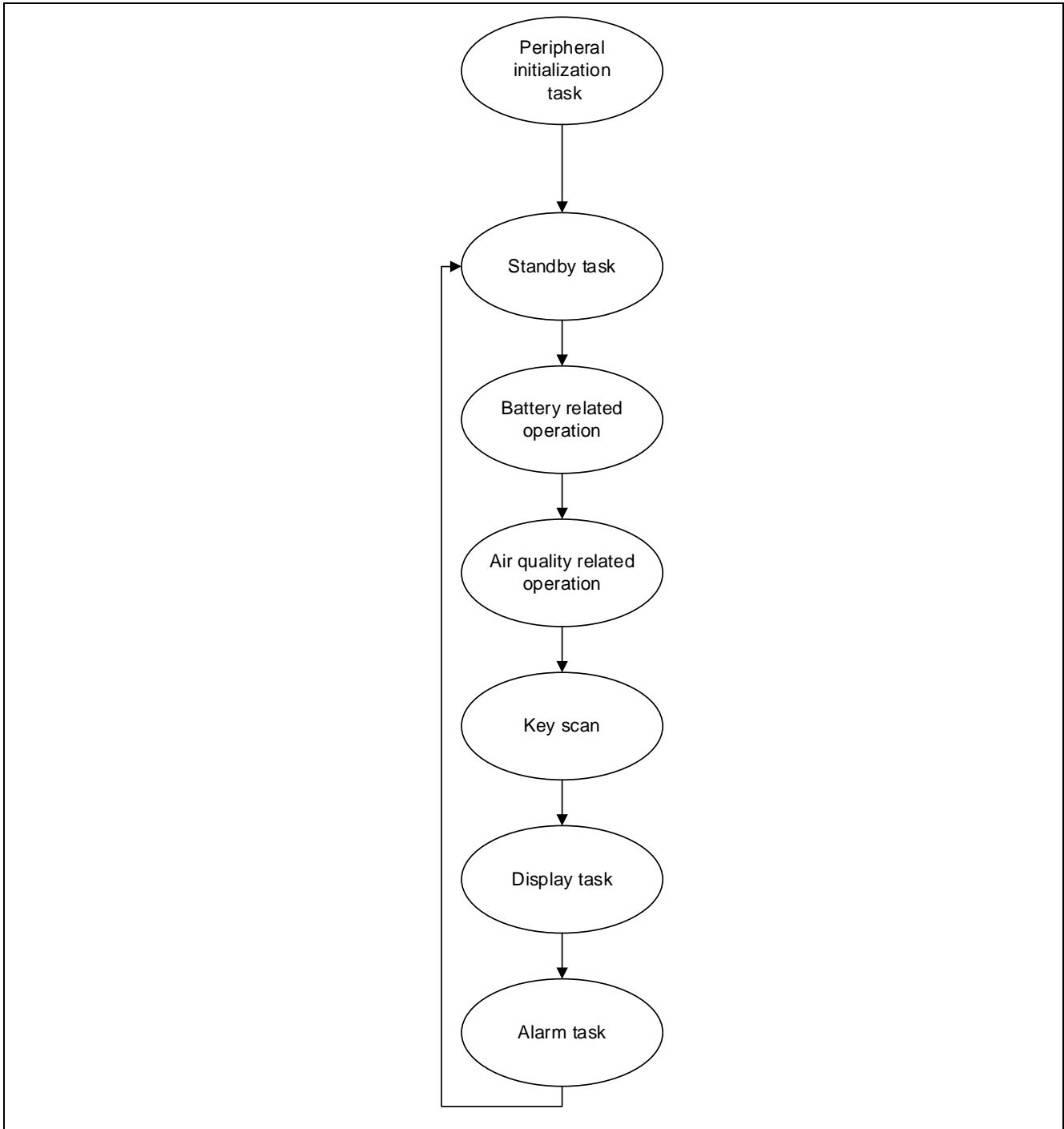

Figure 5.1 Tasks Transition Block Diagram

(1) Peripheral Initialization Task

After reset, the system powers on and executes initialization routine of each module.

(2) Standby Task

After system initialization, the system enters STOP mode and waits for an interrupt trigger of the real-time clock. Once triggered, the system enters interrupt wake-up task.

(3) Battery Related Operation

In this task, the system obtains battery amount data and judges whether it is low. It also detects whether there is any load connected to it in discharge mode, and detects charging status in charge mode.

(4) Air-quality Related Operation

The system drives the particle sensor to detect air quality and decide the level, also, the system would judge whether the air quality index exceeds the pre-set value.

(5) Display Task

The LCD is used to display current PM2.5 concentration. The LED lights are used to show current battery amount and air quality data.

(6) Alarm Task

Either the battery is lower than 3.5 V or the PM2.5 concentration is higher than the threshold value which is set by users, the buzzer will sound.

5.4 Flow Chart

5.4.1 Main Processing

Figure 5.2 shows the flowchart for main processing routine.

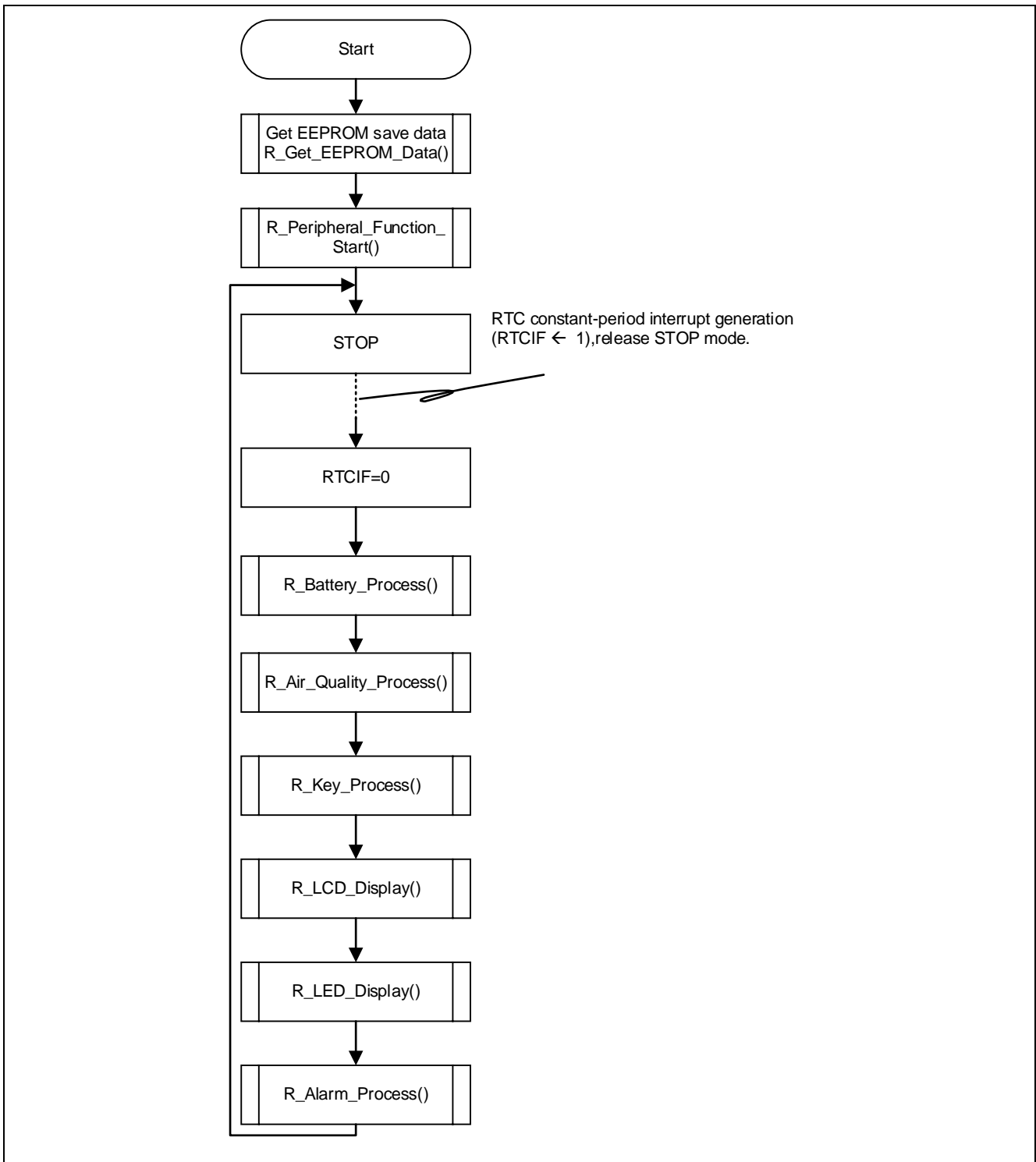

Figure 5.2 Main Processing

5.4.2 Get EEPROM Data

After system initialization, system enters standby processing, and the processing will be completed after 10 s.

Figure 5.3 shows the flowchart for standby task processing.

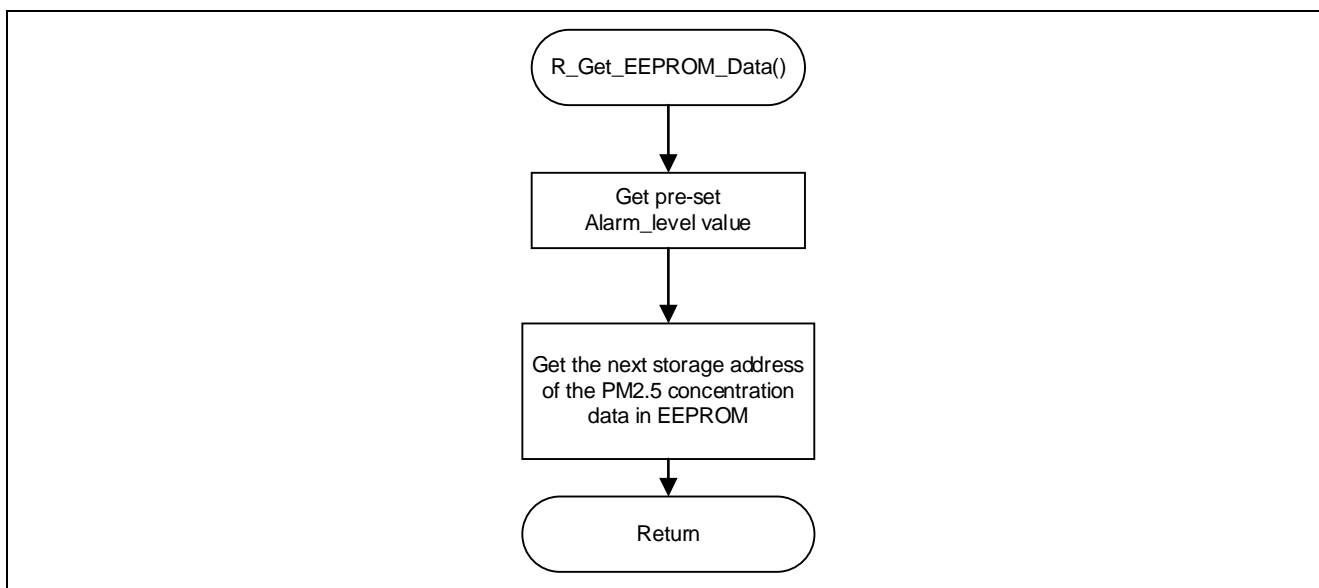

Figure 5.3 Get EEPROM Data



5.4.3 Peripheral function Start

Figure 5.4 shows the flowchart for the alarm task processing of peripheral function start.

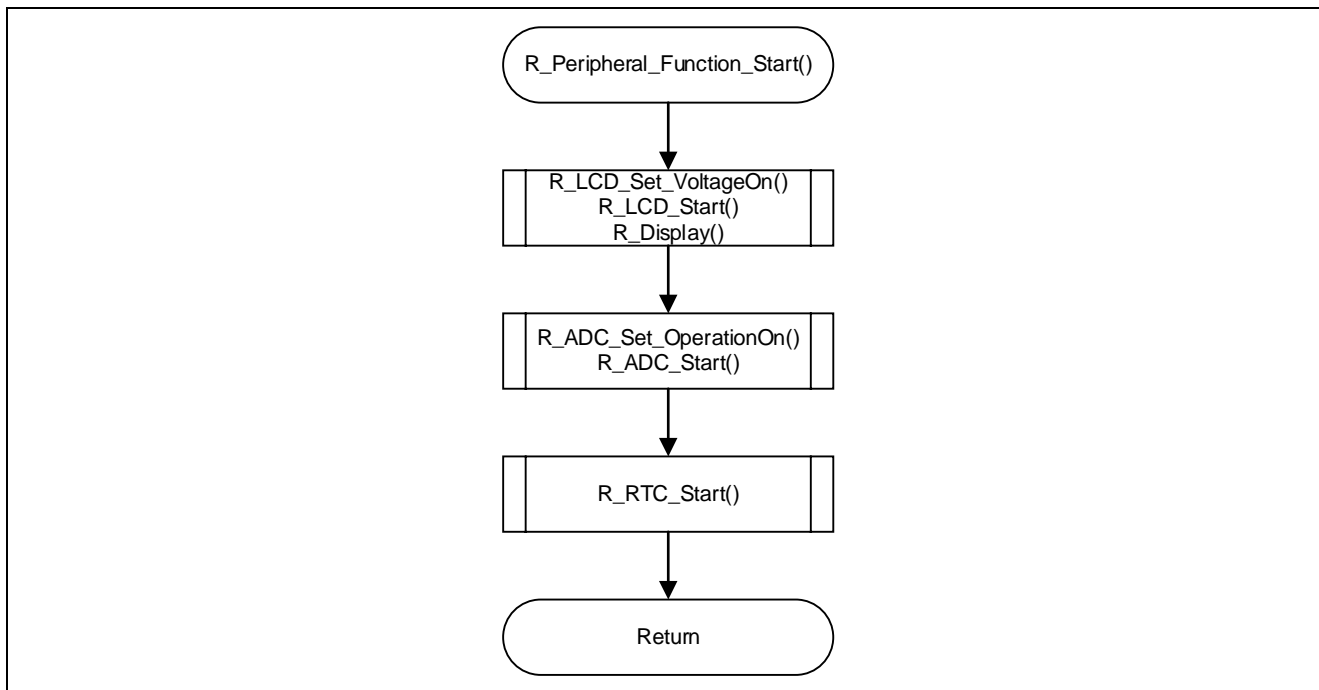

Figure 5.4 Peripheral Function Start

### 5.4.4 Battery processing

Figure 5.5 shows the flowchart for battery processing.

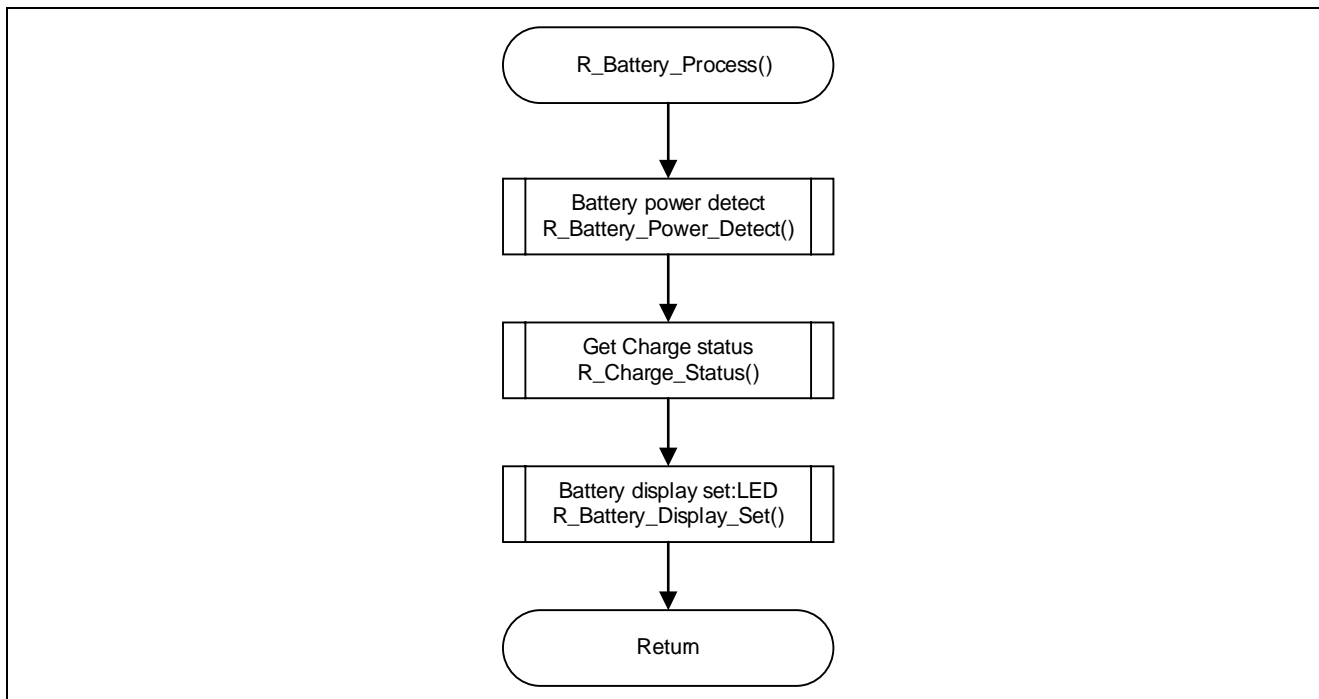

Figure 5.5 Battery Processing

5.4.5 Air quality processing

Figure 5.6 shows the flowchart for Air quality processing.

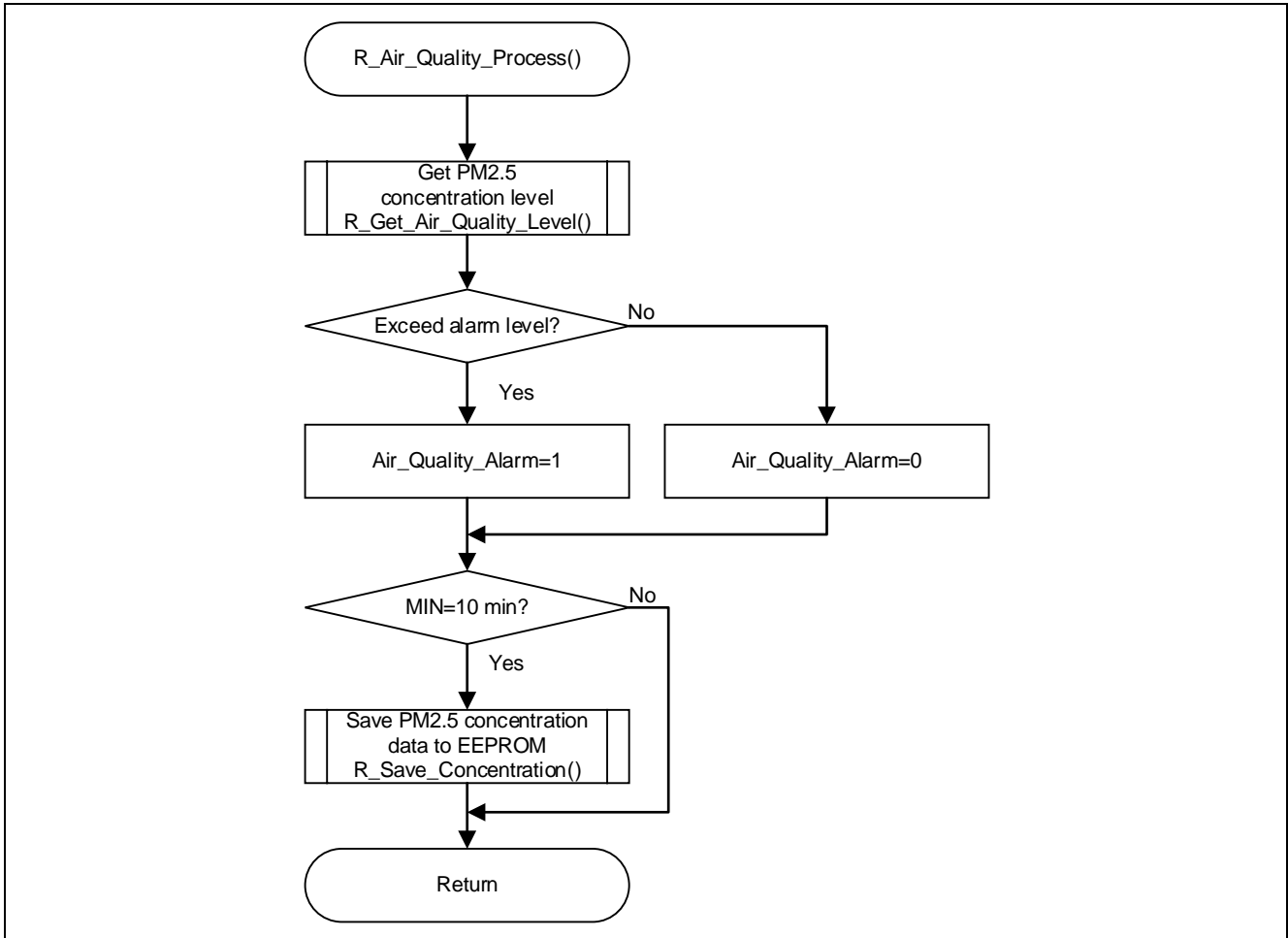

Figure 5.6 Air quality processing

5.4.6 Key processing

Figure 5.7 shows the flowchart for Key processing.

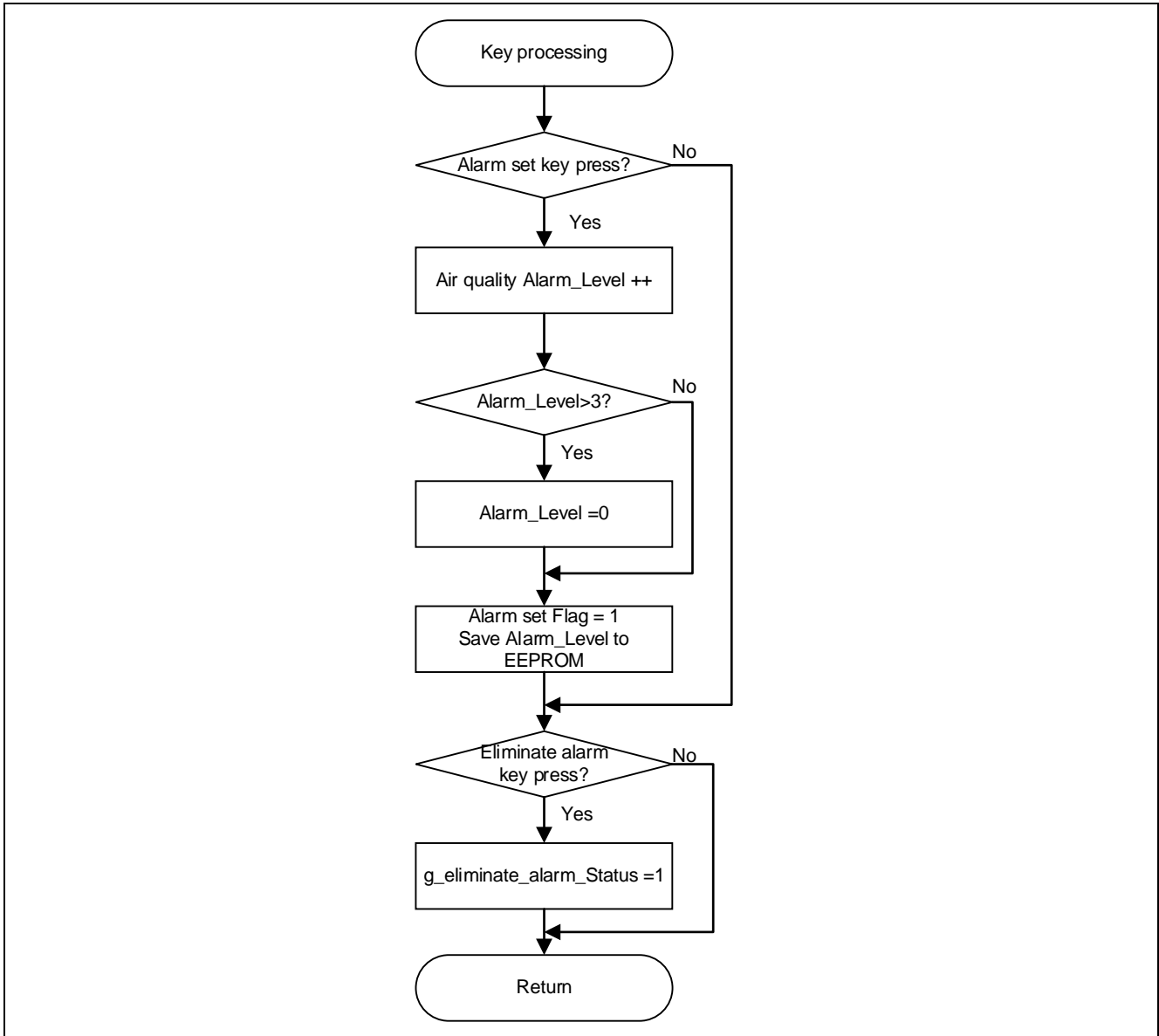

Figure 5.7 Key processing

5.4.7 LCD Display

Figure 5.8 shows the flowchart for LCD display.

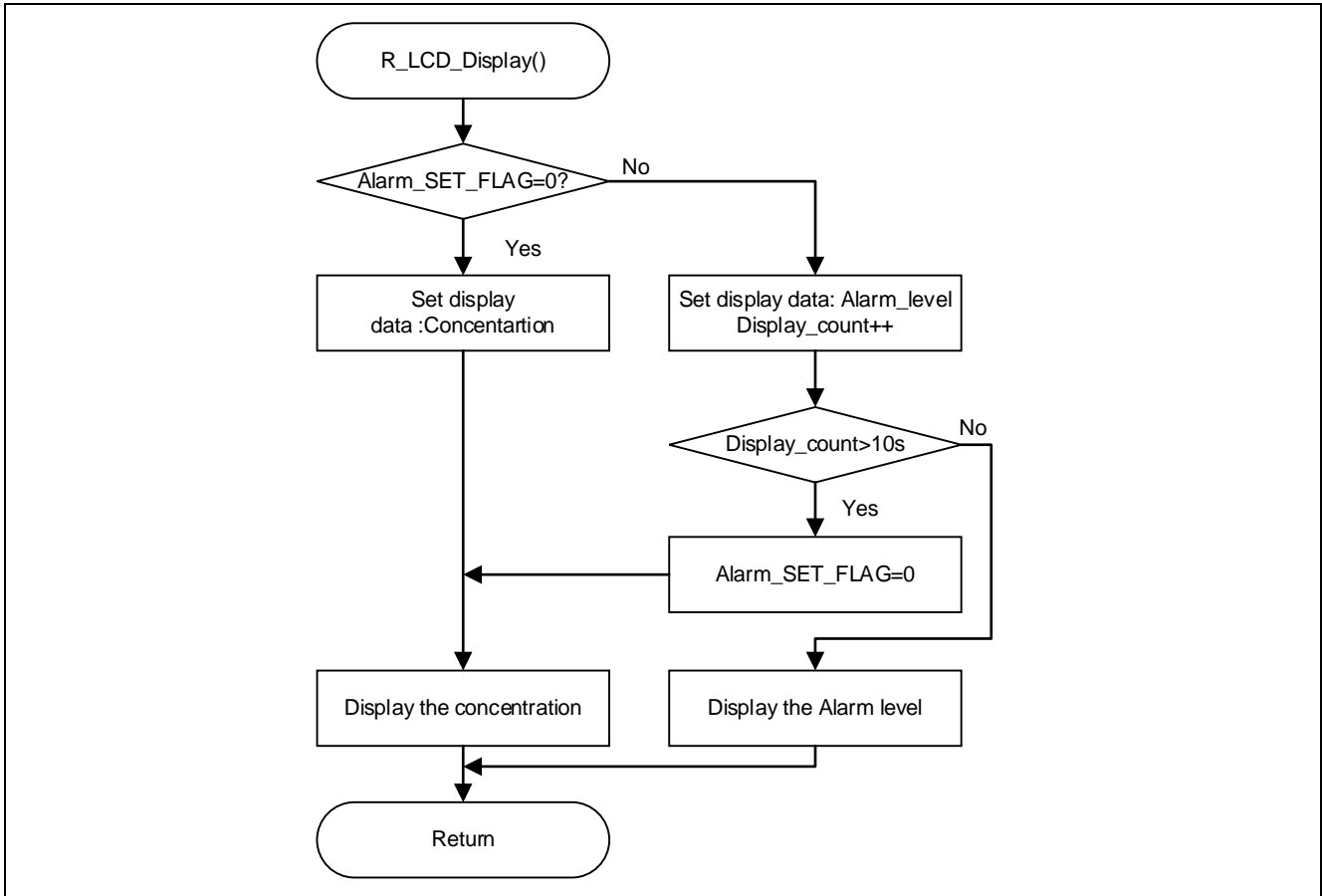

Figure 5.8 LCD Display

5.4.8 LED Display

Figure 5.9 shows the flowchart for LED display.

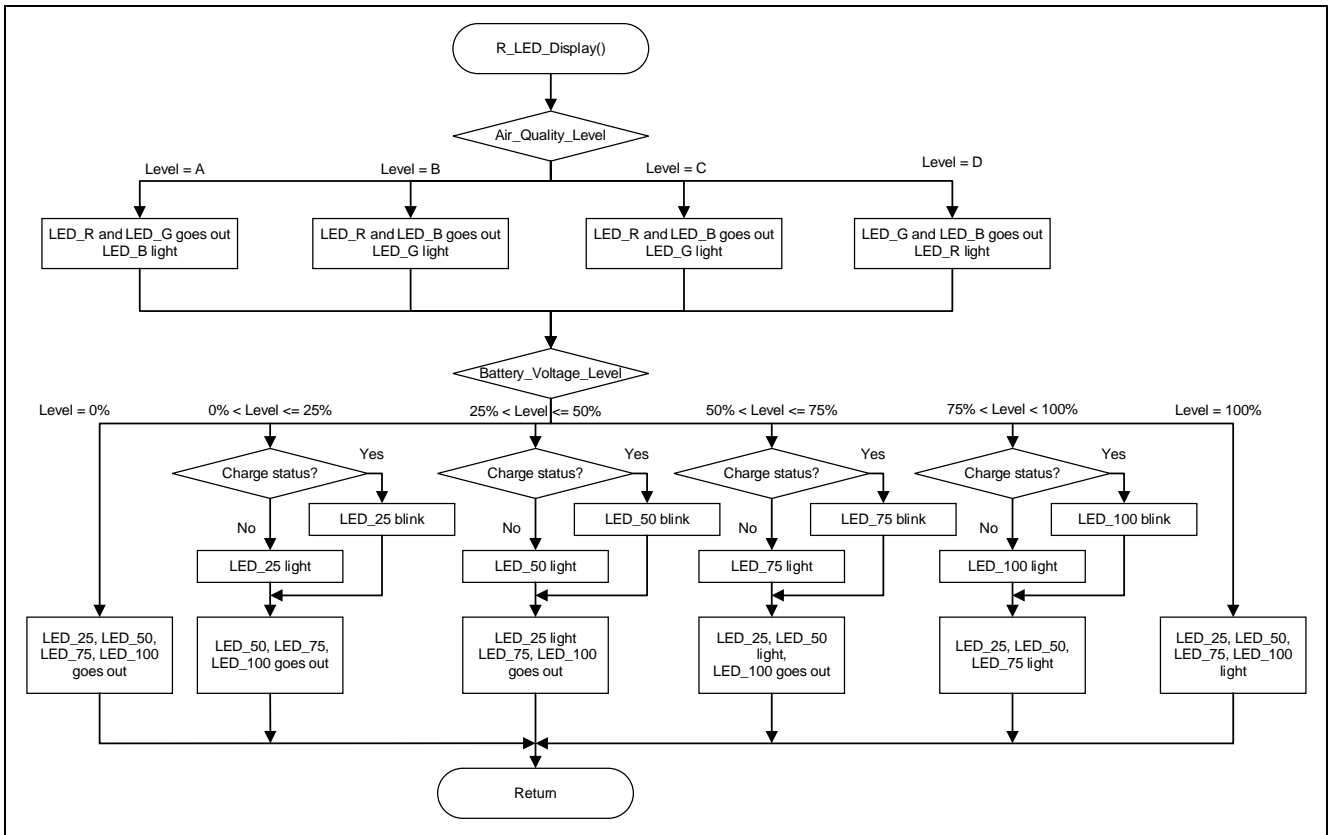

Figure 5.9 LED Display

5.4.9 Alarm processing

Figure 5.10 shows the flowchart for alarm processing.

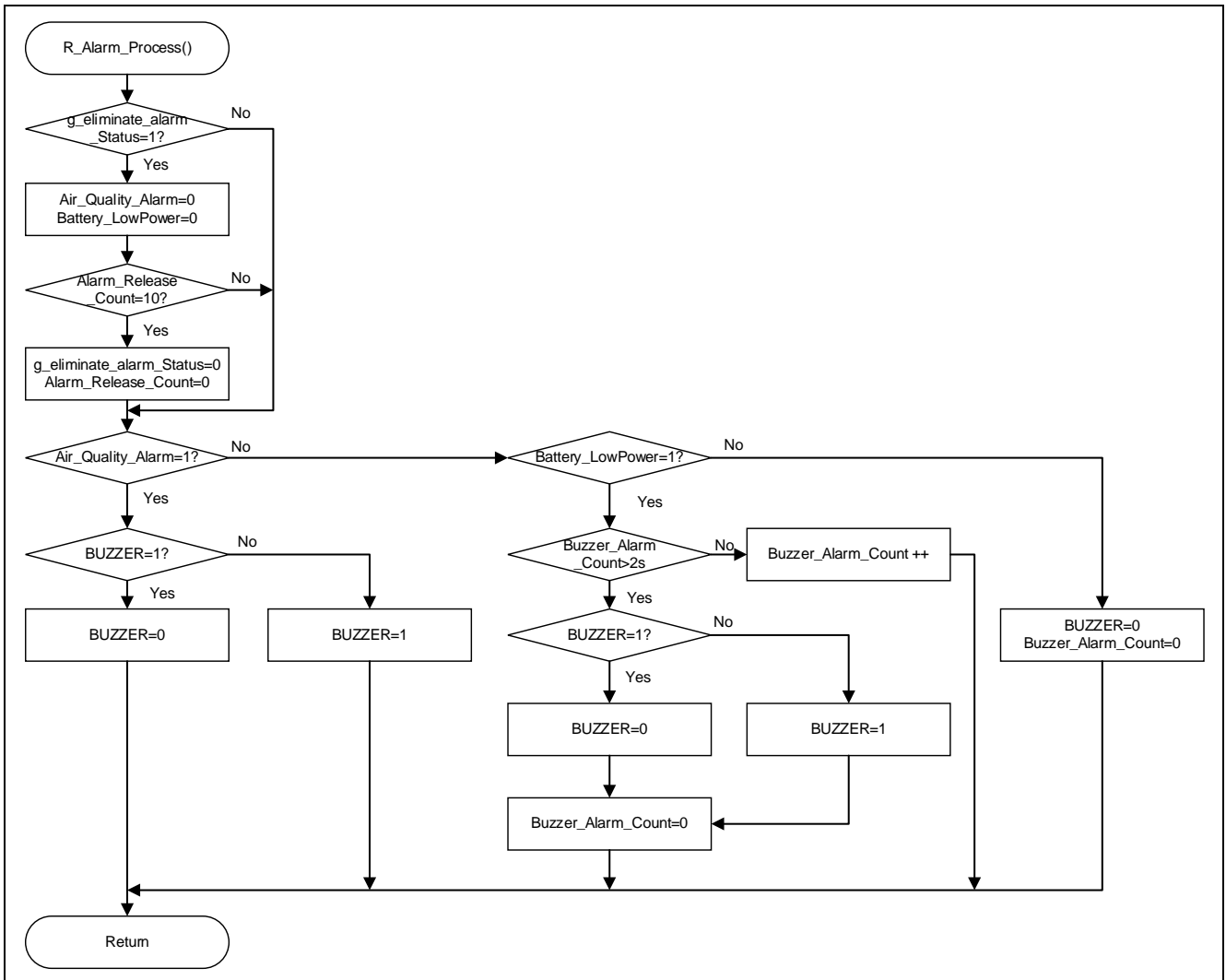

Figure 5.10 Alarm Processing

## 6. Sample Code

The sample code is available on the Renesas Electronics Website.

## 7. Reference Documents

RL78/L12 User's Manual: Hardware (R01UH0330)

RL78 Family User's Manual: Software (R01US0015)

ISL97656 Datasheet

ISL6294 Datasheet

(The latest versions of the documents are available on the Renesas Electronics Website.)

Technical Updates/Technical News

(The latest information can be downloaded from the Renesas Electronics Website.)

## Website and Support

Renesas Electronics Website

<http://www.renesas.com/>

Inquiries

<http://www.renesas.com/contact/>

All trademarks and registered trademarks are the property of their respective owners.



## Revision History

Rev.	Date	Description	
		Page	Summary
1.00	Dec. 31, 2017	—	First edition issued
1.10	Mar. 31, 2019	Page 8	Figure 3.1: added SW2, SW3; deleted 12-bit interval timer
		Page 8	Table 3.2: revised the used pins
		Page 11	Figure 4.1: changed board picture
		Page 15	Figure 4.5: changed battery discharge boost circuit

# General Precautions in the Handling of Microprocessing Unit and Microcontroller Unit Products

The following usage notes are applicable to all Microprocessing unit and Microcontroller unit products from Renesas. For detailed usage notes on the products covered by this document, refer to the relevant sections of the document as well as any technical updates that have been issued for the products.

## 1. Precaution against Electrostatic Discharge (ESD)

A strong electrical field, when exposed to a CMOS device, can cause destruction of the gate oxide and ultimately degrade the device operation. Steps must be taken to stop the generation of static electricity as much as possible, and quickly dissipate it when it occurs. Environmental control must be adequate. When it is dry, a humidifier should be used. This is recommended to avoid using insulators that can easily build up static electricity. Semiconductor devices must be stored and transported in an anti-static container, static shielding bag or conductive material. All test and measurement tools including work benches and floors must be grounded. The operator must also be grounded using a wrist strap. Semiconductor devices must not be touched with bare hands. Similar precautions must be taken for printed circuit boards with mounted semiconductor devices.

## 2. Processing at power-on

The state of the product is undefined at the time when power is supplied. The states of internal circuits in the LSI are indeterminate and the states of register settings and pins are undefined at the time when power is supplied. In a finished product where the reset signal is applied to the external reset pin, the states of pins are not guaranteed from the time when power is supplied until the reset process is completed. In a similar way, the states of pins in a product that is reset by an on-chip power-on reset function are not guaranteed from the time when power is supplied until the power reaches the level at which resetting is specified.

## 3. Input of signal during power-off state

Do not input signals or an I/O pull-up power supply while the device is powered off. The current injection that results from input of such a signal or I/O pull-up power supply may cause malfunction and the abnormal current that passes in the device at this time may cause degradation of internal elements. Follow the guideline for input signal during power-off state as described in your product documentation.

## 4. Handling of unused pins

Handle unused pins in accordance with the directions given under handling of unused pins in the manual. The input pins of CMOS products are generally in the high-impedance state. In operation with an unused pin in the open-circuit state, extra electromagnetic noise is induced in the vicinity of the LSI, an associated shoot-through current flows internally, and malfunctions occur due to the false recognition of the pin state as an input signal become possible.

## 5. Clock signals

After applying a reset, only release the reset line after the operating clock signal becomes stable. When switching the clock signal during program execution, wait until the target clock signal is stabilized. When the clock signal is generated with an external resonator or from an external oscillator during a reset, ensure that the reset line is only released after full stabilization of the clock signal. Additionally, when switching to a clock signal produced with an external resonator or by an external oscillator while program execution is in progress, wait until the target clock signal is stable.

## 6. Voltage application waveform at input pin

Waveform distortion due to input noise or a reflected wave may cause malfunction. If the input of the CMOS device stays in the area between  $V_{IL}$  (Max.) and  $V_{IH}$  (Min.) due to noise, for example, the device may malfunction. Take care to prevent chattering noise from entering the device when the input level is fixed, and also in the transition period when the input level passes through the area between  $V_{IL}$  (Max.) and  $V_{IH}$  (Min.).

## 7. Prohibition of access to reserved addresses

Access to reserved addresses is prohibited. The reserved addresses are provided for possible future expansion of functions. Do not access these addresses as the correct operation of the LSI is not guaranteed.

## 8. Differences between products

Before changing from one product to another, for example to a product with a different part number, confirm that the change will not lead to problems. The characteristics of a microprocessing unit or microcontroller unit products in the same group but having a different part number might differ in terms of internal memory capacity, layout pattern, and other factors, which can affect the ranges of electrical characteristics, such as characteristic values, operating margins, immunity to noise, and amount of radiated noise. When changing to a product with a different part number, implement a system-evaluation test for the given product.

## Notice

1. Descriptions of circuits, software and other related information in this document are provided only to illustrate the operation of semiconductor products and application examples. You are fully responsible for the incorporation or any other use of the circuits, software, and information in the design of your product or system. Renesas Electronics disclaims any and all liability for any losses and damages incurred by you or third parties arising from the use of these circuits, software, or information.
  2. Renesas Electronics hereby expressly disclaims any warranties against and liability for infringement or any other claims involving patents, copyrights, or other intellectual property rights of third parties, by or arising from the use of Renesas Electronics products or technical information described in this document, including but not limited to, the product data, drawings, charts, programs, algorithms, and application examples.
  3. No license, express, implied or otherwise, is granted hereby under any patents, copyrights or other intellectual property rights of Renesas Electronics or others.
  4. You shall not alter, modify, copy, or reverse engineer any Renesas Electronics product, whether in whole or in part. Renesas Electronics disclaims any and all liability for any losses or damages incurred by you or third parties arising from such alteration, modification, copying or reverse engineering.
  5. Renesas Electronics products are classified according to the following two quality grades: "Standard" and "High Quality". The intended applications for each Renesas Electronics product depends on the product's quality grade, as indicated below.
    - "Standard": Computers; office equipment; communications equipment; test and measurement equipment; audio and visual equipment; home electronic appliances; machine tools; personal electronic equipment; industrial robots; etc.
    - "High Quality": Transportation equipment (automobiles, trains, ships, etc.); traffic control (traffic lights); large-scale communication equipment; key financial terminal systems; safety control equipment; etc.
- Unless expressly designated as a high reliability product or a product for harsh environments in a Renesas Electronics data sheet or other Renesas Electronics document, Renesas Electronics products are not intended or authorized for use in products or systems that may pose a direct threat to human life or bodily injury (artificial life support devices or systems; surgical implantations; etc.), or may cause serious property damage (space system; undersea repeaters; nuclear power control systems; aircraft control systems; key plant systems; military equipment; etc.). Renesas Electronics disclaims any and all liability for any damages or losses incurred by you or any third parties arising from the use of any Renesas Electronics product that is inconsistent with any Renesas Electronics data sheet, user's manual or other Renesas Electronics document.
6. When using Renesas Electronics products, refer to the latest product information (data sheets, user's manuals, application notes, "General Notes for Handling and Using Semiconductor Devices" in the reliability handbook, etc.), and ensure that usage conditions are within the ranges specified by Renesas Electronics with respect to maximum ratings, operating power supply voltage range, heat dissipation characteristics, installation, etc. Renesas Electronics disclaims any and all liability for any malfunctions, failure or accident arising out of the use of Renesas Electronics products outside of such specified ranges.
  7. Although Renesas Electronics endeavors to improve the quality and reliability of Renesas Electronics products, semiconductor products have specific characteristics, such as the occurrence of failure at a certain rate and malfunctions under certain use conditions. Unless designated as a high reliability product or a product for harsh environments in a Renesas Electronics data sheet or other Renesas Electronics document, Renesas Electronics products are not subject to radiation resistance design. You are responsible for implementing safety measures to guard against the possibility of bodily injury, injury or damage caused by fire, and/or danger to the public in the event of a failure or malfunction of Renesas Electronics products, such as safety design for hardware and software, including but not limited to redundancy, fire control and malfunction prevention, appropriate treatment for aging degradation or any other appropriate measures. Because the evaluation of microcomputer software alone is very difficult and impractical, you are responsible for evaluating the safety of the final products or systems manufactured by you.
  8. Please contact a Renesas Electronics sales office for details as to environmental matters such as the environmental compatibility of each Renesas Electronics product. You are responsible for carefully and sufficiently investigating applicable laws and regulations that regulate the inclusion or use of controlled substances, including without limitation, the EU RoHS Directive, and using Renesas Electronics products in compliance with all these applicable laws and regulations. Renesas Electronics disclaims any and all liability for damages or losses occurring as a result of your noncompliance with applicable laws and regulations.
  9. Renesas Electronics products and technologies shall not be used for or incorporated into any products or systems whose manufacture, use, or sale is prohibited under any applicable domestic or foreign laws or regulations. You shall comply with any applicable export control laws and regulations promulgated and administered by the governments of any countries asserting jurisdiction over the parties or transactions.
  10. It is the responsibility of the buyer or distributor of Renesas Electronics products, or any other party who distributes, disposes of, or otherwise sells or transfers the product to a third party, to notify such third party in advance of the contents and conditions set forth in this document.
  11. This document shall not be reprinted, reproduced or duplicated in any form, in whole or in part, without prior written consent of Renesas Electronics.
  12. Please contact a Renesas Electronics sales office if you have any questions regarding the information contained in this document or Renesas Electronics products.

(Note1) "Renesas Electronics" as used in this document means Renesas Electronics Corporation and also includes its directly or indirectly controlled subsidiaries.

(Note2) "Renesas Electronics product(s)" means any product developed or manufactured by or for Renesas Electronics.

(Rev.4.0-1 November 2017)

## Corporate Headquarters

TOYOSU FORESIA, 3-2-24 Toyosu,  
Koto-ku, Tokyo 135-0061, Japan  
[www.renesas.com](http://www.renesas.com)

## Trademarks

Renesas and the Renesas logo are trademarks of Renesas Electronics Corporation. All trademarks and registered trademarks are the property of their respective owners.

## Contact information

For further information on a product, technology, the most up-to-date version of a document, or your nearest sales office, please visit:  
[www.renesas.com/contact/](http://www.renesas.com/contact/).