

RL78/G1D Group

RL78/G1D Evaluation Board User's Manual

RENESAS MCU
RL78 Family

All information contained in these materials, including products and product specifications, represents information on the product at the time of publication and is subject to change by Renesas Electronics Corp. without notice. Please review the latest information published by Renesas Electronics Corp. through various means, including the Renesas Electronics Corp. website (<http://www.renesas.com>).

Notice

1. Descriptions of circuits, software and other related information in this document are provided only to illustrate the operation of semiconductor products and application examples. You are fully responsible for the incorporation or any other use of the circuits, software, and information in the design of your product or system. Renesas Electronics disclaims any and all liability for any losses and damages incurred by you or third parties arising from the use of these circuits, software, or information.
2. Renesas Electronics hereby expressly disclaims any warranties against and liability for infringement or any other claims involving patents, copyrights, or other intellectual property rights of third parties, by or arising from the use of Renesas Electronics products or technical information described in this document, including but not limited to, the product data, drawings, charts, programs, algorithms, and application examples.
3. No license, express, implied or otherwise, is granted hereby under any patents, copyrights or other intellectual property rights of Renesas Electronics or others.
4. You shall be responsible for determining what licenses are required from any third parties, and obtaining such licenses for the lawful import, export, manufacture, sales, utilization, distribution or other disposal of any products incorporating Renesas Electronics products, if required.
5. You shall not alter, modify, copy, or reverse engineer any Renesas Electronics product, whether in whole or in part. Renesas Electronics disclaims any and all liability for any losses or damages incurred by you or third parties arising from such alteration, modification, copying or reverse engineering.
6. Renesas Electronics products are classified according to the following two quality grades: "Standard" and "High Quality". The intended applications for each Renesas Electronics product depends on the product's quality grade, as indicated below.

"Standard": Computers; office equipment; communications equipment; test and measurement equipment; audio and visual equipment; home electronic appliances; machine tools; personal electronic equipment; industrial robots; etc.

"High Quality": Transportation equipment (automobiles, trains, ships, etc.); traffic control (traffic lights); large-scale communication equipment; key financial terminal systems; safety control equipment; etc.

Unless expressly designated as a high reliability product or a product for harsh environments in a Renesas Electronics data sheet or other Renesas Electronics document, Renesas Electronics products are not intended or authorized for use in products or systems that may pose a direct threat to human life or bodily injury (artificial life support devices or systems; surgical implantations; etc.), or may cause serious property damage (space system; undersea repeaters; nuclear power control systems; aircraft control systems; key plant systems; military equipment; etc.). Renesas Electronics disclaims any and all liability for any damages or losses incurred by you or any third parties arising from the use of any Renesas Electronics product that is inconsistent with any Renesas Electronics data sheet, user's manual or other Renesas Electronics document.

7. No semiconductor product is absolutely secure. Notwithstanding any security measures or features that may be implemented in Renesas Electronics hardware or software products, Renesas Electronics shall have absolutely no liability arising out of any vulnerability or security breach, including but not limited to any unauthorized access to or use of a Renesas Electronics product or a system that uses a Renesas Electronics product. RENESAS ELECTRONICS DOES NOT WARRANT OR GUARANTEE THAT RENESAS ELECTRONICS PRODUCTS, OR ANY SYSTEMS CREATED USING RENESAS ELECTRONICS PRODUCTS WILL BE INVULNERABLE OR FREE FROM CORRUPTION, ATTACK, VIRUSES, INTERFERENCE, HACKING, DATA LOSS OR THEFT, OR OTHER SECURITY INTRUSION ("Vulnerability Issues"). RENESAS ELECTRONICS DISCLAIMS ANY AND ALL RESPONSIBILITY OR LIABILITY ARISING FROM OR RELATED TO ANY VULNERABILITY ISSUES. FURTHERMORE, TO THE EXTENT PERMITTED BY APPLICABLE LAW, RENESAS ELECTRONICS DISCLAIMS ANY AND ALL WARRANTIES, EXPRESS OR IMPLIED, WITH RESPECT TO THIS DOCUMENT AND ANY RELATED OR ACCOMPANYING SOFTWARE OR HARDWARE, INCLUDING BUT NOT LIMITED TO THE IMPLIED WARRANTIES OF MERCHANTABILITY, OR FITNESS FOR A PARTICULAR PURPOSE.
8. When using Renesas Electronics products, refer to the latest product information (data sheets, user's manuals, application notes, "General Notes for Handling and Using Semiconductor Devices" in the reliability handbook, etc.), and ensure that usage conditions are within the ranges specified by Renesas Electronics with respect to maximum ratings, operating power supply voltage range, heat dissipation characteristics, installation, etc. Renesas Electronics disclaims any and all liability for any malfunctions, failure or accident arising out of the use of Renesas Electronics products outside of such specified ranges.
9. Although Renesas Electronics endeavors to improve the quality and reliability of Renesas Electronics products, semiconductor products have specific characteristics, such as the occurrence of failure at a certain rate and malfunctions under certain use conditions. Unless designated as a high reliability product or a product for harsh environments in a Renesas Electronics data sheet or other Renesas Electronics document, Renesas Electronics products are not subject to radiation resistance design. You are responsible for implementing safety measures to guard against the possibility of bodily injury, injury or damage caused by fire, and/or danger to the public in the event of a failure or malfunction of Renesas Electronics products, such as safety design for hardware and software, including but not limited to redundancy, fire control and malfunction prevention, appropriate treatment for aging degradation or any other appropriate measures. Because the evaluation of microcomputer software alone is very difficult and impractical, you are responsible for evaluating the safety of the final products or systems manufactured by you.
10. Please contact a Renesas Electronics sales office for details as to environmental matters such as the environmental compatibility of each Renesas Electronics product. You are responsible for carefully and sufficiently investigating applicable laws and regulations that regulate the inclusion or use of controlled substances, including without limitation, the EU RoHS Directive, and using Renesas Electronics products in compliance with all these applicable laws and regulations. Renesas Electronics disclaims any and all liability for damages or losses occurring as a result of your noncompliance with applicable laws and regulations.
11. Renesas Electronics products and technologies shall not be used for or incorporated into any products or systems whose manufacture, use, or sale is prohibited under any applicable domestic or foreign laws or regulations. You shall comply with any applicable export control laws and regulations promulgated and administered by the governments of any countries asserting jurisdiction over the parties or transactions.
12. It is the responsibility of the buyer or distributor of Renesas Electronics products, or any other party who distributes, disposes of, or otherwise sells or transfers the product to a third party, to notify such third party in advance of the contents and conditions set forth in this document.
13. This document shall not be reprinted, reproduced or duplicated in any form, in whole or in part, without prior written consent of Renesas Electronics.
14. Please contact a Renesas Electronics sales office if you have any questions regarding the information contained in this document or Renesas Electronics products.

(Note1) "Renesas Electronics" as used in this document means Renesas Electronics Corporation and also includes its directly or indirectly controlled subsidiaries.

(Note2) "Renesas Electronics product(s)" means any product developed or manufactured by or for Renesas Electronics.

(Rev.5.0-1 October 2020)

Corporate Headquarters

TOYOSU FORESIA, 3-2-24 Toyosu,
Koto-ku, Tokyo 135-0061, Japan
www.renesas.com

Trademarks

Renesas and the Renesas logo are trademarks of Renesas Electronics Corporation. All trademarks and registered trademarks are the property of their respective owners.

Contact information

For further information on a product, technology, the most up-to-date version of a document, or your nearest sales office, please visit:
www.renesas.com/contact/.

General Precautions in the Handling of Microprocessing Unit and Microcontroller Unit Products

The following usage notes are applicable to all Microprocessing unit and Microcontroller unit products from Renesas. For detailed usage notes on the products covered by this document, refer to the relevant sections of the document as well as any technical updates that have been issued for the products.

1. Precaution against Electrostatic Discharge (ESD)

A strong electrical field, when exposed to a CMOS device, can cause destruction of the gate oxide and ultimately degrade the device operation. Steps must be taken to stop the generation of static electricity as much as possible, and quickly dissipate it when it occurs. Environmental control must be adequate. When it is dry, a humidifier should be used. This is recommended to avoid using insulators that can easily build up static electricity. Semiconductor devices must be stored and transported in an anti-static container, static shielding bag or conductive material. All test and measurement tools including work benches and floors must be grounded. The operator must also be grounded using a wrist strap. Semiconductor devices must not be touched with bare hands. Similar precautions must be taken for printed circuit boards with mounted semiconductor devices.

2. Processing at power-on

The state of the product is undefined at the time when power is supplied. The states of internal circuits in the LSI are indeterminate and the states of register settings and pins are undefined at the time when power is supplied. In a finished product where the reset signal is applied to the external reset pin, the states of pins are not guaranteed from the time when power is supplied until the reset process is completed. In a similar way, the states of pins in a product that is reset by an on-chip power-on reset function are not guaranteed from the time when power is supplied until the power reaches the level at which resetting is specified.

3. Input of signal during power-off state

Do not input signals or an I/O pull-up power supply while the device is powered off. The current injection that results from input of such a signal or I/O pull-up power supply may cause malfunction and the abnormal current that passes in the device at this time may cause degradation of internal elements. Follow the guideline for input signal during power-off state as described in your product documentation.

4. Handling of unused pins

Handle unused pins in accordance with the directions given under handling of unused pins in the manual. The input pins of CMOS products are generally in the high-impedance state. In operation with an unused pin in the open-circuit state, extra electromagnetic noise is induced in the vicinity of the LSI, an associated shoot-through current flows internally, and malfunctions occur due to the false recognition of the pin state as an input signal become possible.

5. Clock signals

After applying a reset, only release the reset line after the operating clock signal becomes stable. When switching the clock signal during program execution, wait until the target clock signal is stabilized. When the clock signal is generated with an external resonator or from an external oscillator during a reset, ensure that the reset line is only released after full stabilization of the clock signal. Additionally, when switching to a clock signal produced with an external resonator or by an external oscillator while program execution is in progress, wait until the target clock signal is stable.

6. Voltage application waveform at input pin

Waveform distortion due to input noise or a reflected wave may cause malfunction. If the input of the CMOS device stays in the area between V_{IL} (Max.) and V_{IH} (Min.) due to noise, for example, the device may malfunction. Take care to prevent chattering noise from entering the device when the input level is fixed, and also in the transition period when the input level passes through the area between V_{IL} (Max.) and V_{IH} (Min.).

7. Prohibition of access to reserved addresses

Access to reserved addresses is prohibited. The reserved addresses are provided for possible future expansion of functions. Do not access these addresses as the correct operation of the LSI is not guaranteed.

8. Differences between products

Before changing from one product to another, for example to a product with a different part number, confirm that the change will not lead to problems. The characteristics of a microprocessing unit or microcontroller unit products in the same group but having a different part number might differ in terms of internal memory capacity, layout pattern, and other factors, which can affect the ranges of electrical characteristics, such as characteristic values, operating margins, immunity to noise, and amount of radiated noise. When changing to a product with a different part number, implement a system-evaluation test for the given product.

Table of Contents

1.	Overview	1
1.1	Specification Outline	2
2.	Detailed Specifications	3
2.1	RL78/G1D Evaluation Board Appearance	3
2.2	Descriptions of Each Part	4
3.	Settings	5
3.1	Slide Switch Settings	5
4.	Connector	7
4.1	RL78/G1D Module Interface	7
4.2	E1 Debug Interface	7
4.3	USB Interface	7
4.4	External Extension Interface	8
4.5	Extension Interface of RL78/G1D Module	8
5.	I/O	9
5.1	Push Switches	9
5.2	DIP Switch	9
5.3	LEDs	10
5.4	USB Interface	10
6.	Power Supply	11
6.1	Power Line System	11
6.2	DC Jack Input Power	12
7.	Notes	13
8.	Circuit Diagrams	14
8.1	Diagram of RL78/G1D Module Connection	14
8.2	Circuit Diagrams of Extension Board for Bluetooth Low Energy Evaluation	16
	Appendix A. The UART- USB Conversion Device Driver	19
	Appendix B. Conformity Assessment	20

The *Bluetooth*[®] word mark and logos are registered trademarks owned by Bluetooth SIG, Inc. and any use of such marks by Renesas Electronics Corporation is under license. Other trademarks and trade names are those of their respective owners.

These commodities, technology or software, must be exported in accordance with the export administration regulations of the exporting country. Diversion contrary to the law of that country is prohibited.

Usage Notes of Evaluation Board

The regulations of international specifications and Japan's domestic laws restrict the usage of wireless receivers and transmitters.

Observe the specifications and laws of the country in which the RF transceiver is used.

Representative specifications for the band of 2.4 GHz are shown below.

Japan: ARIB STD-T66

United States: FCC 47CFR part15.207, part15.209 and part15.247

Europe: EN 300 328 and EN 301 489

1. Overview

This document explains Renesas Electronics' RL78/G1D evaluation board (RTK0EN0001D01001BZ).

Figure 1-1 shows a block diagram of this evaluation board.

This evaluation board consists of a module on which the RL78/G1D is mounted (RTK0EN0002C01001BZ) and an extension board for Bluetooth Low Energy evaluation (R0K3ZBBBDBN00BR) with peripheral functions such as push switches and LEDs.

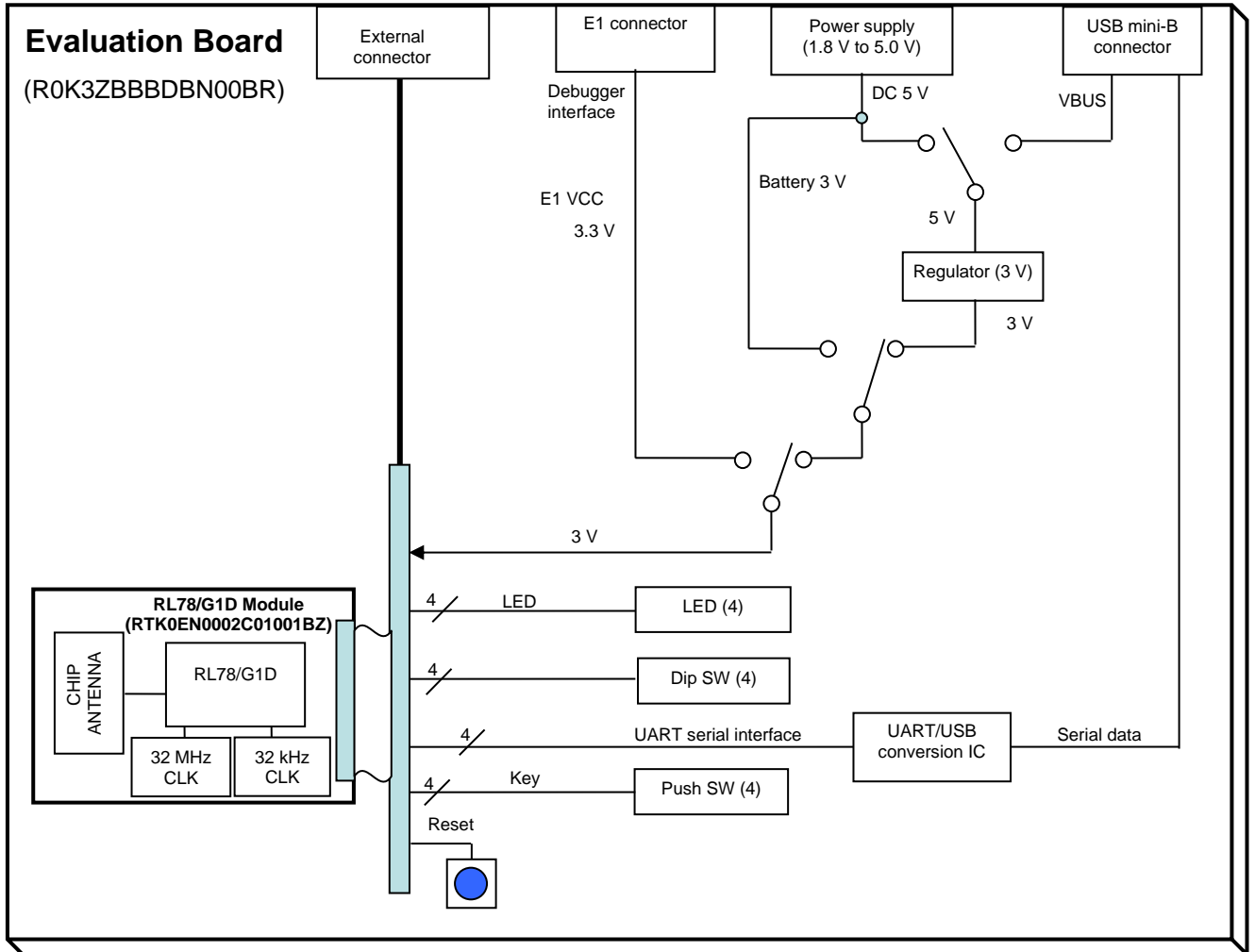

Figure 1-1 RL78/G1D Evaluation Board (RTK0EN0001D01001BZ) Block Diagram

1.1 Specification Outline

Table 1-1 shows the specifications of the RL78/G1D evaluation board.

Table 1-1 RL78/G1D Evaluation Board Specifications

Item	Contents
Wireless module	RL78/G1D module (RTK0EN0002C01001BZ)
USB communication	<ul style="list-style-type: none"> • USB interface USB mini-B connector UART0 on the RL78/G1D can be used as a USB input/output port by using a UART-USB conversion device. When the board is connected to a computer, the computer virtually handles the USB port as a COM port for communication by using a device driver.
Input functions	<ul style="list-style-type: none"> • RESET switch • DIP switch (4-pole switch) • Push switches (four)
Display	Four LEDs
Debug interface	2.54 mm pitch male connector with accidental insertion protection for connecting to an E1 emulator
Power supply voltage	One of the following power supplies can be selected by using slide switches. (For the slide switches, see 6. <i>Power Supply</i> .) <ol style="list-style-type: none"> 1. AC adapter 5.0 V or DC jack for battery box input Power supply jack: OD ϕ 5.5 mm, ID ϕ 2.0 mm, outside: minus, inside: plus 2. USB VBUS 5 V 3. 3.3 V supplied from E1 emulator
Supply current	1 A or higher
Supply voltage for each part	Power supply for the RL78/G1D module: 1.8 V to 3.6 V Power supply for peripherals: 1.8 V to 3.6 V
Dimension	Board size: 55 mm x 90 mm x 18 mm
Operating ambient temperature/humidity	0°C to +60°C, 10% to 80% RH (non condensing)
Storage temperature	-15°C to +60°C, 10% to 80% RH (non condensing)

Note: This evaluation board does not include an AC adapter or battery box.

2. Detailed Specifications

2.1 RL78/G1D Evaluation Board Appearance

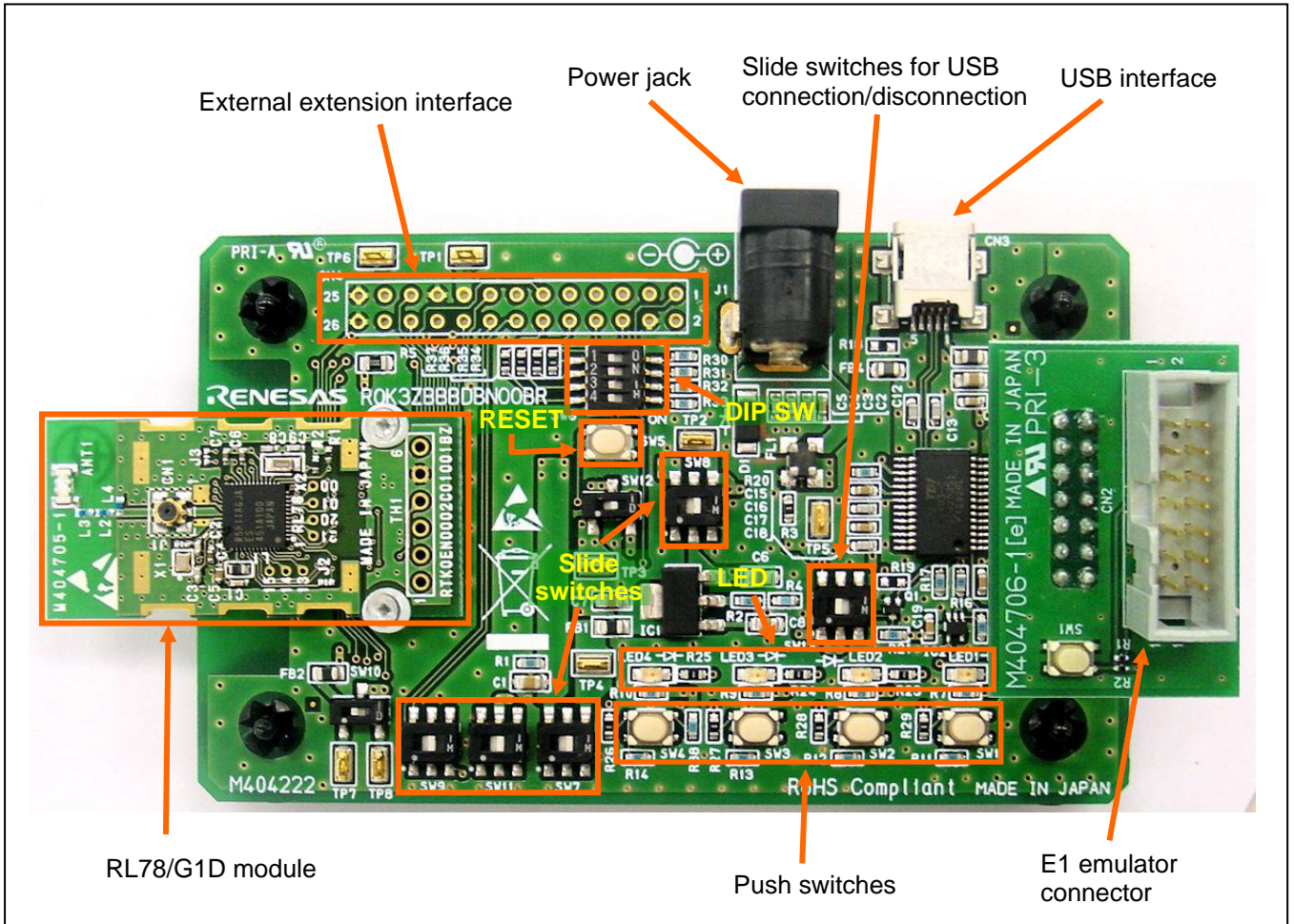

Figure 2-1 Board Appearance

2.2 Descriptions of Each Part

(1) CN1 connector that connects the RL78/G1D module

The RL78/G1D module is connected to CN1 on the extension board for Bluetooth Low Energy evaluation.

Do not remove the module from the extension board. Otherwise, the module or the board might malfunction.

(2) Slide switches for switching the power supply (SW7, SW8, and SW11)

The power supply for the evaluation board can be selected by using slide switches. Four types of power supplies are provided: AC adapter input (DC 5 V) from the DC jack (J1), battery box input (DC plug 3 V), USB VBUS input (5 V), and E1 input (3.3 V) available when the E1 emulator is connected.

If the AC adapter input (DC 5 V) or USB VBUS input (5 V) is selected, 3.0 V is generated by a regulator.

The AC adapter DC input, VBUS input, and E1 are switched by using the slide switches. Battery box input (3.0 V) and E1 input (3.3 V) can also be switched by using the slide switches.

(3) I/O

The evaluation board has a USB interface, push switches, a DIP switch (SW6), and LEDs for I/O. The interface of the push switches, DIP switch, and LEDs can be electrically separated from the RL78/G1D module by removing the 0 Ω resistors.

(4) E1 emulator connector

The E1 connector is provided to connect the Renesas Electronics on-chip debugging emulator E1 (sold separately).

(5) RESET

The evaluation board has a RESET switch (SW5). Use this switch to reset the RL78/G1D module.

(6) External extension interface

External extension interface pins are provided on the evaluation board in order to connect the I/O ports of the RL78/G1D module to an external system.

3. Settings

3.1 Slide Switch Settings

Table 3-1 shows the functions implemented by using the slide switches on the evaluation board and their operations. In this table, the factory settings are shown in bold face and italicized. Figure 3-1 shows the positions at which the slide switches are placed, and Figure 3-2 shows the factory setting of the slide switches.

Table 3-1 Functions of Slide Switches on RTK0EN0001D01001BZ

No.	Function	1-2 connected (left)	2-3 connected (right)
SW7	Selects DC/VBUS or battery as the power supply.	Power is directly supplied from the battery.	<i>Power is supplied from the DC/VBUS via a regulator.</i>
SW8	Selects DC 5 V or VBUS as the power supply.	<i>Power is supplied from DC 5 V.</i>	Power is supplied from USB VBUS.
SW9	Switches between USB and external extension interface.	Connected to an external extension interface.	<i>Connected to a USB device.</i>
SW10	Switches the power supply line.	<i>Power is supplied to the module.</i>	The power supply line is left open. (Current consumption can be measured by using TP7 and TP8.)
SW11	Selects the E1 debugger (3.3 V) or another source as the power supply.	3.3 V is supplied directly from the E1 debugger.	<i>Power is supplied from a source other than the E1 debugger (3.3 V).</i>
SW12	Unused	Do not use this switch.	<i>Set this switch to the right.</i>
SW13	Connects or disconnects the USB interface. ^{Note}	<i>The USB interface is connected.</i>	The USB interface is disconnected.

Note: When not using the USB interface, set SW9 to '1-2 connected' and SW13 to '2-3 connected'; these disconnect the buffer power supply and prevent leak current flowing to the signal level conversion buffer connected between the RL78/G1D and UART-USB conversion IC.

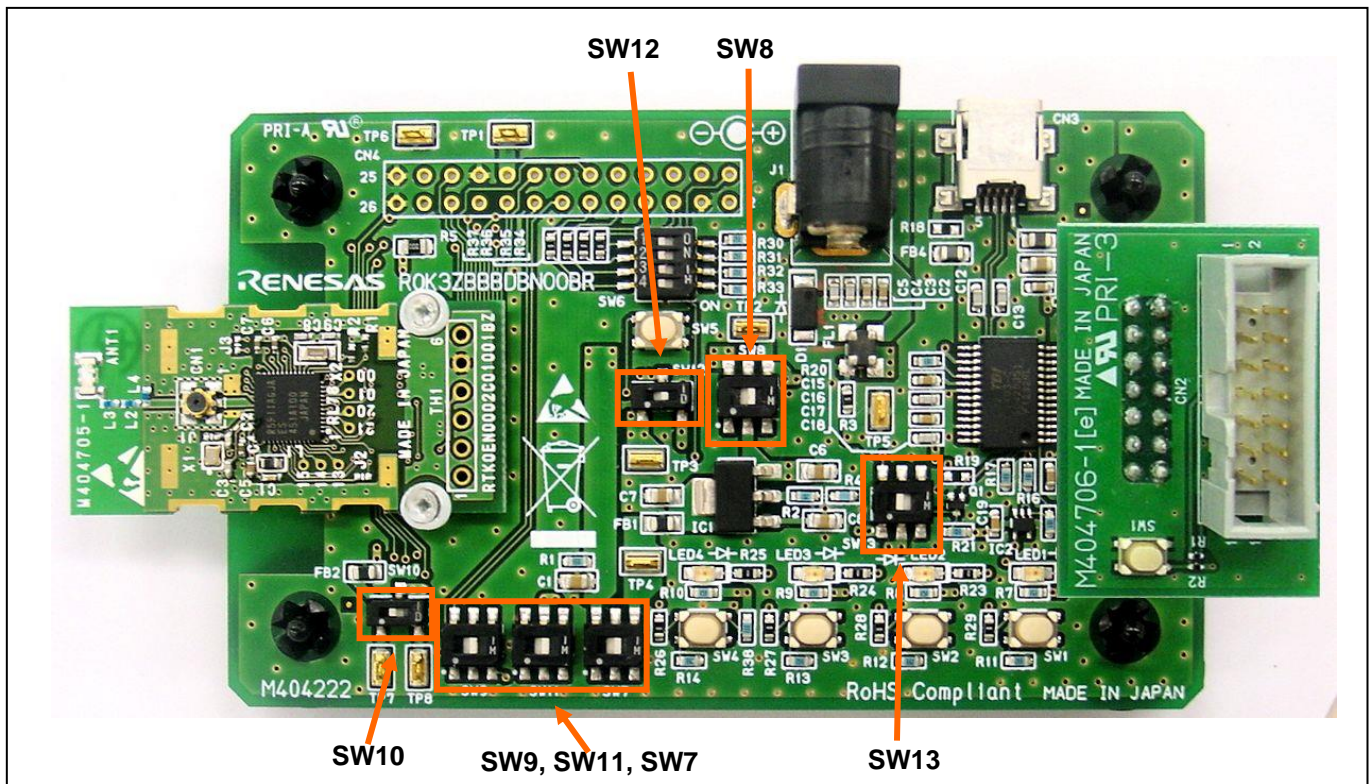

Figure 3-1 Mounting Positions of Slide Switches

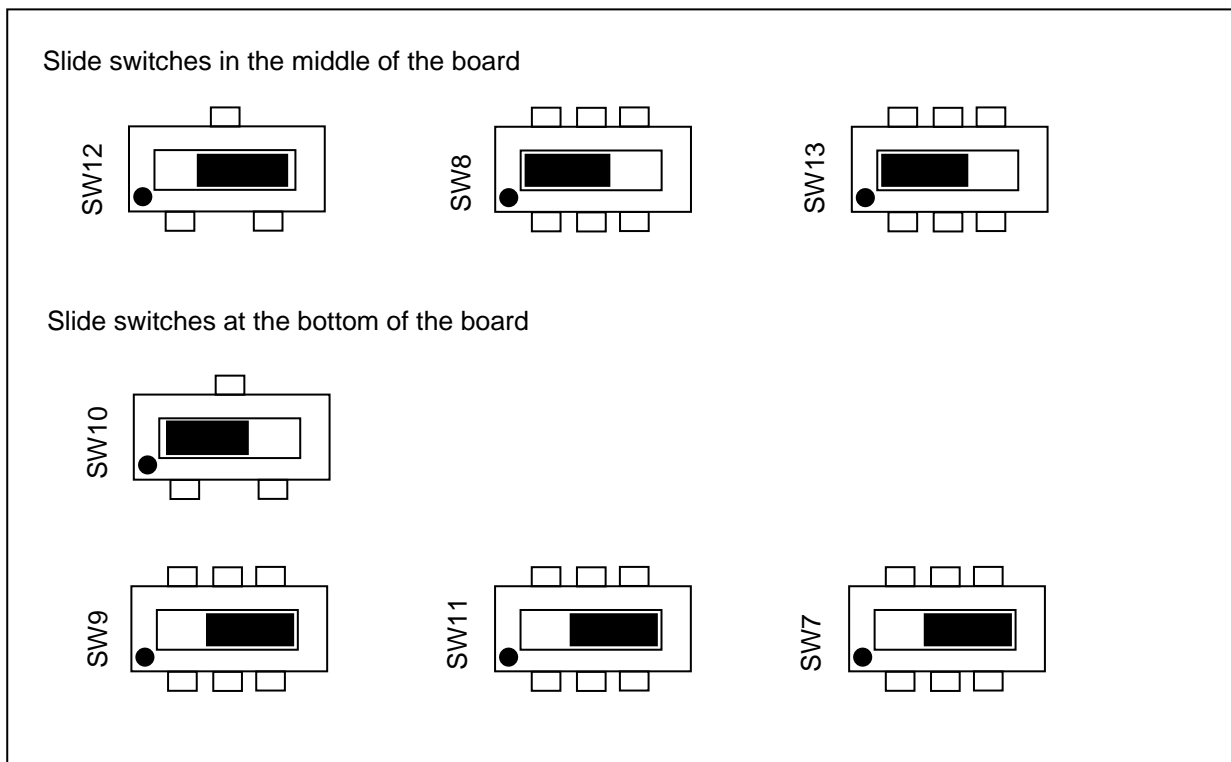

Figure 3-2 Slide Switches Factory Settings

4. Connector

4.1 RL78/G1D Module Interface

CN1 is used to connect the RL78/G1D module. Table 4-1 shows the assignment of the CN1 connector pins.

Table 4-1 Assignment of CN1 Connector Pins

Pin	Signal name	Pin	Signal name
1	VSS	13	P02/ANI17/ TXD1 / SW6-4
2	VDD	14	P10/SCK00/SCL00 / SW6-1
3	P40/TOOL0	15	GPIO0/TXSELH_RF / SW6-3
4	N.C.	16	P22/ANI2 / SW4
5	RESET	17	GPIO1/TXSELL_RF / SW6-2
6	N.C.	18	P23/ANI3 / SW3
7	P60/SCLA0 / LED4	19	N.C./ SW1
8	P61/SDAA0	20	P16/TI01/TO01/INTP5 / SW2
9	P03/ANI16/ RXD1 / LED3	21	VSS
10	P11/SI00/RXD0/SDA00 / RxD	22	P30/INTP3/RTC1HZ/UPON (VBUS detection)
11	P147/ANI18 / LED2	23	P120/ANI19 / LED1
12	P12/SO00/TXD0/TxD	24	N.C.

4.2 E1 Debug Interface

CN2 is used to connect Renesas Electronics on-chip debugging emulator E1 (sold separately) via conversion adapter. Table 4-2 shows the assignment of the CN2 connector pins when a conversion adapter is connected.

Table 4-2 Assignment of CN2 Connector Pins

Pin	Signal name	Pin	Signal name
1	N.C.	8	VDD
2	GND	9	VDD
3	N.C.	10	RESET#
4	N.C.	11	N.C.
5	TOOL0	12	GND
6	RESET_IN#	13	RESET#
7	N.C.	14	GND

4.3 USB Interface

CN3 is used to communicate with external devices by using the USB interface via a UART-USB conversion device. Table 4-3 shows the assignment of the CN3 connector pins.

Table 4-3 Assignment of CN3 Connector Pins

Pin	Signal name	Pin	Signal name
1	VBUS	4	N.C.
2	MD	5	GND
3	MP	6	CH

4.4 External Extension Interface

CN4 is provided as an external extension interface for when you want to connect and external device. Table 4-4 shows the assignment of the CN4 connector pins.

Table 4-4 Assignment of CN4 External Extension Connector Pins

Pin	Signal name	Pin	Signal name
1	P30/INTP3/RTC1HZ / UPON (VBUS detection)	14	P12/SO00/TXD0 / TxD
2	VCC3 (3V)	15	P120/ANI19 / LED1
3	P61/SDAA0	16	P11/SI00/RXD0/SDA00 / RxD
4	GND	17	VCC3
5	P23/ANI3 / SW3	18	N.C./ SW1
6	P10/SCK00/SCL00 / SW6-1	19	GND
7	P147/ANI18 / LED2	20	P16/TI01/TO01/INTP5 / SW2
8	GPIO1/TXSELL_RF / SW6-2	21	P40/TOOL0
9	P03/ANI16 /RXD1 LED3	22	RESET
10	GPIO0/TXSELH_RF / SW6-3	23	N.C.
11	P60/SCLA0 / LED4	24	5.0 V
12	P02/ANI17/SIO/TXD1 / SW6-4	25	GND
13	P22/ANI2 / SW4	26	GND

4.5 Extension Interface of RL78/G1D Module

Through-holes are provided as an extension interface if you want to use the module as a standalone device. Figure 4-1 shows the pin assignment of the through-hole. Use the pins of CN1 and the through-hole exclusively.

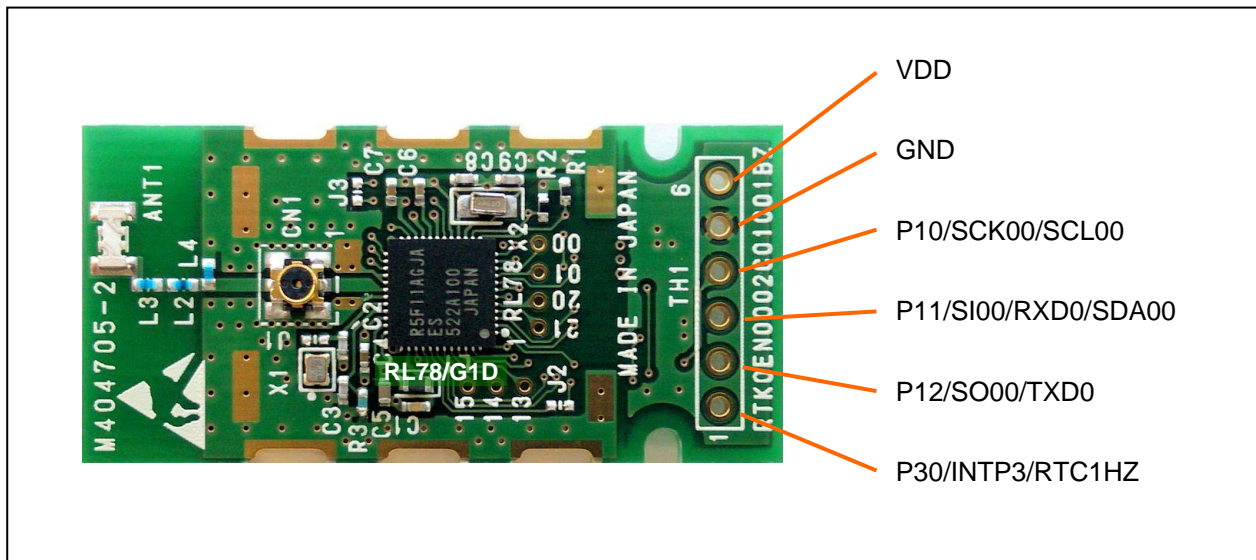

Figure 4-1 Assignment of Through-hole Pins

5. I/O

General-purpose ports on the RL78/G1D module are connected to the extension board for Bluetooth Low Energy evaluation via connectors. This section describes the interface for each I/O.

5.1 Push Switches

To use the push switches, enable the pull-up resistors incorporated in the RL78/G1D module. The level of the corresponding general-purpose ports becomes high when the switches are off and low when the switches are on. Table 5-1 shows the relationship between the push switch ports and the RL78/G1D module.

Table 5-1 Push Switches

	Pin No.	Port
SW1	CN1-19	N.C.
SW2	CN1-20	P16
SW3	CN1-18	P23
SW4	CN1-16	P22

Remark: Enable the on-chip pull-up resistor connected to P16 (in input mode) on the RL78/G1D. P22 is pulled up on the extension board for Bluetooth Low Energy evaluation. Connect a resistor of 100 kΩ to CN4 to pull up P23.

5.2 DIP Switch

To use the DIP switch, enable the pull-up resistors on the RL78/G1D module. The level of the corresponding general-purpose ports becomes high when the switch is set to off and low when the switch is set to on. At shipment, SW6-1 to SW6-4 are set to off. Table 5-2 shows the relationship between the DIP switch and the RL78/G1D module ports.

Table 5-2 DIP Switch

	Pin No.	Port
SW6-1	CN1-14	P10
SW6-2	CN1-17	–
SW6-3	CN1-15	–
SW6-4	CN1-13	P02

5.3 LEDs

The LEDs on the evaluation board are turned off when a high level is output to the corresponding general-purpose port and turned on when a low level is output.

Table 5-3 shows the relationship between the LEDs and the RL78/G1D module ports.

Table 5-3 LED

	Pin No.	Port
LED1	CN1-23	P120
LED2	CN1-11	P147
LED3	CN1-9	P03
LED4	CN1-7	P60

Remark: The LEDs become dim when the voltage is 2.2 V or lower.

5.4 USB Interface

By using a UART-USB conversion device, the evaluation board can use UART0 on the RL78/G1D to communicate with an external device. To communicate with a computer, connect a USB cable (A type male or mini-B male) to the CN3 connector. Communication with a computer does not require flow control.

A circuit to detect connection to a computer is also provided. When a low level is input to general-purpose port P30 on the RL78/G1D module, it indicates that the evaluation board is connected to the computer. When a high level is input, it indicates that the evaluation board is not connected.

When not using the USB interface, set the slide switch SW9 to '1-2 connected' and SW13 to '2-3 connected'; these disconnect the buffer power supply and prevent leak current flowing from the signal level conversion buffer between the RL78/G1D and UART-USB conversion IC.

Table 5-4 shows the relationship between the USB interface and the RL78/G1D module ports.

Table 5-4 USB Interface

	Pin No.	Port
UPON (VBUS detection)	CN1-22	P30
TxD	CN1-12	P12
RxD	CN1-10	P11

To communicate with an external device via the USB interface by using UART0 of RL78/G1D, a UART-USB conversion device driver must be installed in the computer. Install the driver referring to the appendix in this document.

For detailed specifications of UART-USB conversion, see the manual of the UART-USB conversion IC FT232RL (manufactured by Future Technology Devices International Ltd. in the UK).

6. Power Supply

6.1 Power Line System

The evaluation board operates on the power supply selected by using the slide switches: AC adapter input (DC 5 V) from the jack (J1), battery box input (DC plug 3 V), USB VBUS input (5 V), or E1 input (3.3 V; when the E1 emulator is connected). Do not select 5 V when connection is established by E1 emulator software.

When the AC adapter input (DC 5 V) or USB VBUS input (5 V) is selected, 3.0 V is generated by the regulator.

Figure 6-1 shows the power line system.

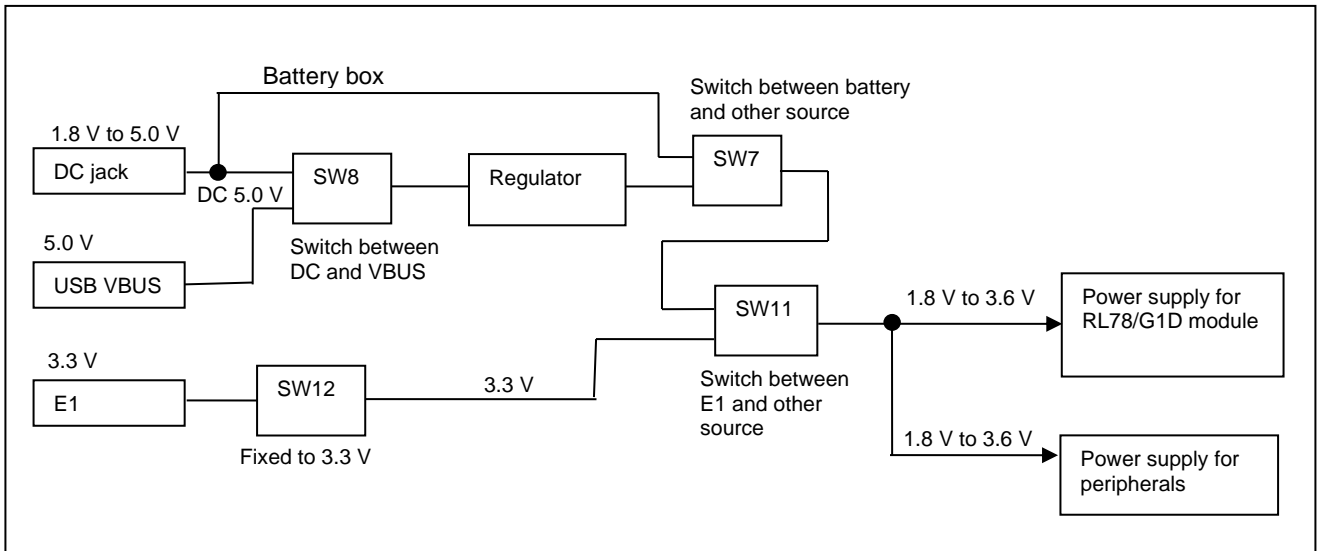

Figure 6-1 Power Line System

Table 6-1 shows operating modes and the settings of the slide switches for power supply input.

Table 6-1 Major Blocks Using Power Supply

Operating mode		Settings of slide switches			Host interface connection (P3_0)
		SW11	SW7	SW8	
Host interface used	DC 5 V power supply input	Pin 3 side (other power supply)	Pin 3 side (DC/VBUS)	Pin 1 side (DC 5 V)	L
	VBUS power supply input	Pin 3 side (other power supply)	Pin 3 side (DC/VBUS)	Pin 3 side (VBUS)	L
	Battery box input	Pin 3 side (other power supply)	Pin 1 side (battery)	–	L
	E1 power supply 3.3 V	Pin 3 side (E1 (3.3 V))	–	–	L
Host interface not used	DC 5 V power supply input	Pin 3 side (other power supply)	Pin 3 side (DC/VBUS)	Pin 1 side (DC 5 V)	H
	Battery box input	Pin 3 side (other power supply)	Pin 1 side (battery)	–	H
	E1 power supply (3.3 V)	Pin 1 side (E1 (3.3 V))	–	–	H

–: Setting not specified.

For SW12, see 3.1.

6.2 DC Jack Input Power

Table 6-2 shows the specifications of the power input from the DC jack on the evaluation board.

Table 6-2 DC Jack Input Power

Item	Specification
Plug	OD ϕ 5.5 mm, ID ϕ 2.0 mm
Polarity of plug	Outside: minus, inside: plus
Input voltage	1.8 V to 5.0 V
Supply current	1 A or higher

7. Notes

This evaluation board includes the extension board for Bluetooth Low Energy evaluation and the RL78/G1D module, which are connected together via a connector and attached by screws and washers. Note that neither the extension board nor the module is covered by warranty if they are detached from each other.

Direction on WEEE (Waste Electrical and Electronic Equipment Directive)



Renesas development tools and products are directly covered by the European Union's Waste Electrical and Electronic Equipment, (WEEE), Directive 2002/96/EC. As a result, this equipment, including all accessories, must not be disposed of as household waste but through your locally recognised recycling or disposal schemes. As part of our commitment to environmental responsibility Renesas also offers to take back the equipment and has implemented a Tools Product Recycling Program for customers in Europe. This allows you to return equipment to Renesas for disposal through our approved Producer Compliance Scheme. To register for the program, click here "<http://www.renesas.com/weee>".

CAUTION

This equipment should be handled like a CMOS semiconductor device. The user must take all precautions to avoid build-up of static electricity while working with this equipment. All test and measurement tool including the workbench must be grounded. The user/operator must be grounded using the wrist strap. The connectors and/or device pins should not be touched with bare hands.

EEDT-ST-004-10

8. Circuit Diagrams

8.1 Diagram of RL78/G1D Module Connection

A diagram of the RL78/G1D module (RTK0EN0002C01001BZ) connection is shown on the next page.

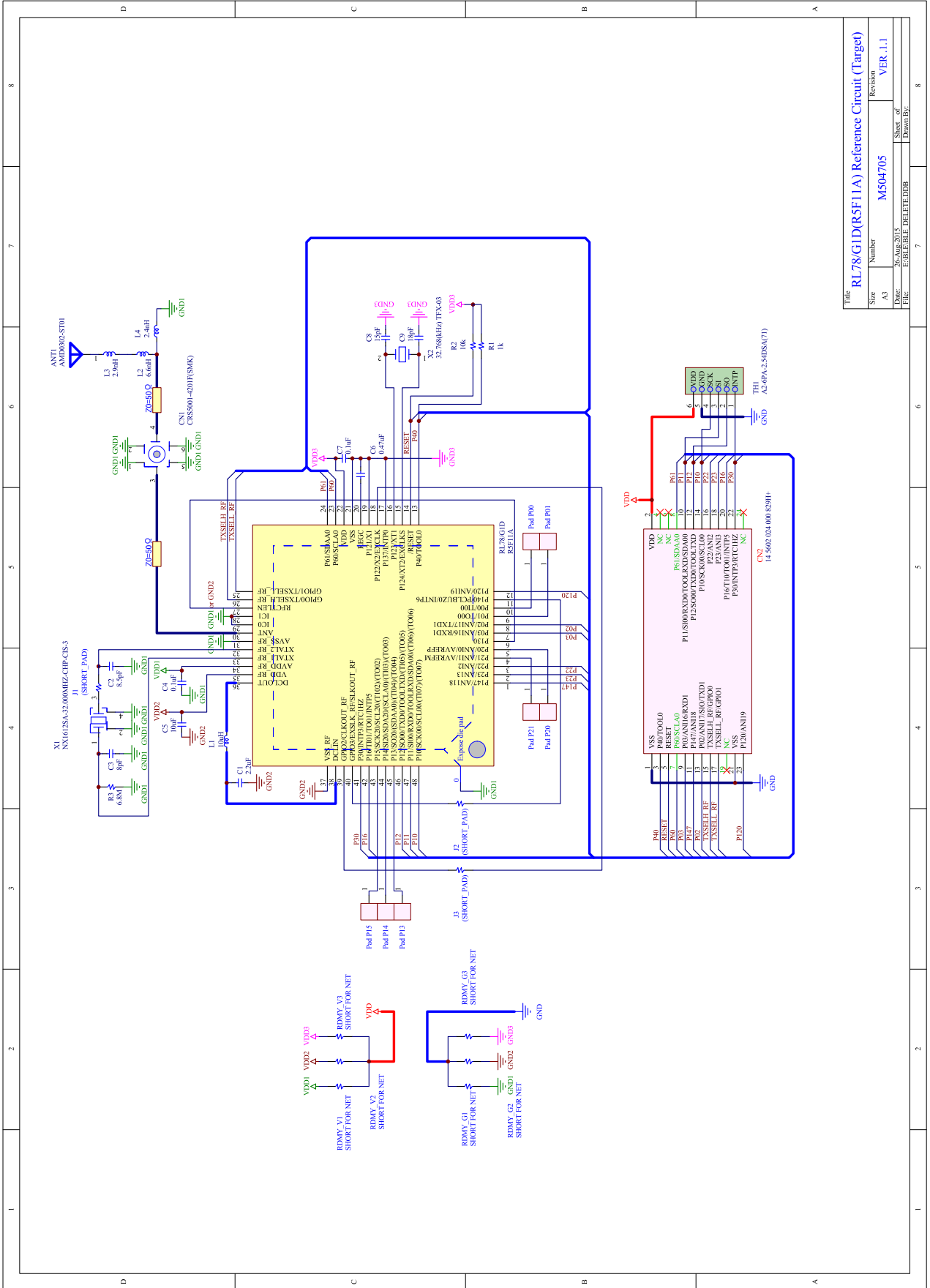

Title		RL78/G1D(R5F11A) Reference Circuit (Target)	
Size	Number	Revision	VER 1.1
Date:	26-Aug-2015	Sheet of	7
File:	ES/LEB/LE/DLE/TE/DOB	Drawn by:	

8.2 Circuit Diagrams of Extension Board for Bluetooth Low Energy Evaluation

Circuit diagrams of the extension board for Bluetooth Low Energy evaluation (R0K3ZBBDBN00BR) are shown on the following pages.

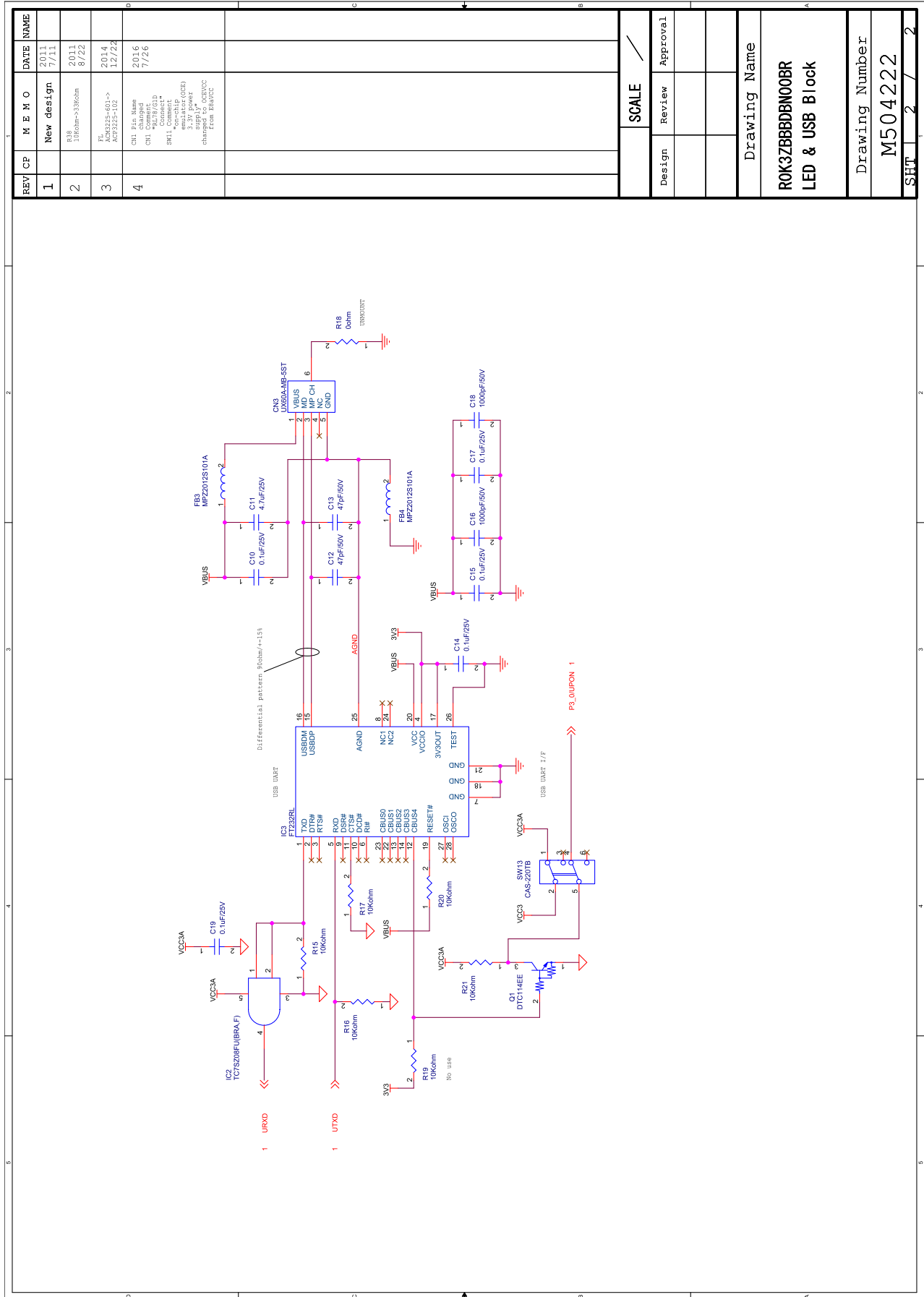

REV	CP	M E M O	DATE	NAME
1		New design	2011/7/11	
2		108 108ohm->330ohm	2011/8/22	
3		PL ACM3225-601-> ACM3225-102	2014/12/22	
4		CH1 Pin Name changed RL78/G1D Comment: SW11 non-chip resistor 3.3V Resistor changed From BRVCC to VCC3A	2016/7/26	

SCALE	
Design	Approval
Review	
Drawing Name	
R0K3ZBBDBN00BR	
LED & USB Block	
Drawing Number	
M504222	
SHEET 2 / 2	

Appendix A. The UART- USB Conversion Device Driver

To communicate with an external device via the USB interface by using UART0 of the RL78/G1D, a UART-USB conversion device (FT232RL) driver must be installed in the computer.

Before connecting the evaluation board to the computer, download the UART-USB conversion IC (FT232RL) driver from the website of FTDI (Future Technology Devices international Ltd.) and install it on your computer.

Appendix B. Conformity Assessment

RL78/G1D evaluation board (RTK0EN0001D01001BZ) conforms to the laws and regulations that are described in the following.

FCC/IC Regulatory

Since this module is not sold to general end users directly, there is no user manual of module.

For the details about this module, please refer to the specification sheet of module.

This module should be installed in the host device according to the interface specification (installation procedure).

The following information must be indicated on the host device of this module;

Contains FCC ID: 2AEMX-G1DEVA

This device complies with part 15 of the FCC Rules. Operation is subject to the following two conditions: (1) This device may not cause harmful interference, and (2) this device must accept any interference received, including interference that may cause undesired operation.

Contains IC: 20194-G1DEVA

The following statements must be described on the user manual of the host device of this module;

[for FCC]

FCC CAUTION

Changes or modifications not expressly approved by the party responsible for compliance could void the user's authority to operate the equipment.

This transmitter must not be co-located or operated in conjunction with any other antenna or transmitter.

This equipment complies with FCC radiation exposure limits set forth for an uncontrolled environment and meets the FCC radio frequency (RF) Exposure Guidelines. This equipment has very low levels of RF energy that it deemed to comply without maximum permissive exposure evaluation (MPE). But it is desirable that it should be installed and operated keeping the radiator at least 20cm or more away from person's body.

[for IC]

This device complies with Industry Canada's licence-exempt RSSs. Operation is subject to the following two conditions: (1) This device may not cause interference; and (2) This device must accept any interference, including interference that may cause undesired operation of the device.

Le présent appareil est conforme aux CNR d'Industrie Canada applicables aux appareils radio exempts de licence.

L'exploitation est autorisée aux deux conditions suivantes : 1) l'appareil ne doit pas produire de brouillage; 2)

l'utilisateur de l'appareil doit accepter tout brouillage radioélectrique subi, même si le brouillage est susceptible d'en compromettre le fonctionnement.

This equipment complies with IC radiation exposure limits set forth for an uncontrolled environment and meets RSS-102 of the IC radio frequency (RF) Exposure rules. This equipment has very low levels of RF energy that it deemed to comply without maximum permissive exposure evaluation (MPE). But it is desirable that it should be installed and operated keeping the radiator at least 20cm or more away from person's body.

Cet équipement est conforme aux limites d'exposition aux rayonnements énoncées pour un environnement non contrôlé et respecte les règles d'exposition aux fréquences radioélectriques (RF) CNR-102 de l'IC. Cet équipement émet une énergie RF très faible qui est considérée conforme sans évaluation de l'exposition maximale autorisée. Cependant, il est souhaitable qu'il devrait être installé et utilisé en gardant une distance de 20 cm ou plus entre le radiateur et le corps humain.

Korea Radio Regulations

MSIP-CRM-R5E-G1DEVA

해당 무선설비는 전파혼신 가능성이 있으므로 인명안전과 관련된 서비스는 할 수 없습니다.

China SRRC

1.

- 使用频率：2.4 - 2.4835 GHz
- 等效全向辐射功率(EIRP)：
天线增益<10dBi 时：≤100 mW 或≤20 dBm
- 最大功率谱密度：
天线增益<10dBi 时：≤20 dBm / MHz (EIRP)
- 载频容限：20 ppm
- 带外发射功率(在 2.4-2.4835GHz 频段以外)
≤-80 dBm / Hz (EIRP)
- 杂散发射(辐射)功率(对应载波±2.5 倍信道带宽以外)：
≤-36 dBm / 100 kHz (30 - 1000 MHz)
≤-33 dBm / 100 kHz (2.4 - 2.4835 GHz)
≤-40 dBm / 1 MHz (3.4 - 3.53 GHz)
≤-40 dBm / 1 MHz (5.725 - 5.85 GHz)
≤-30 dBm / 1 MHz (其它 1 - 12.75 GHz)

2. 不得擅自更改发射频率、加大发射功率(包括额外加装射频功率放大器)，不得擅自外接天线或改用其它发射天线；

3. 使用时不得对各种合法的无线电通信业务产生有害干扰；一旦发现有干扰现象时，应立即停止使用，并采取措施消除干扰后方可继续使用；

4. 使用微功率无线电设备，必须忍受各种无线电业务的干扰或工业、科学及医疗应用设备的辐射干扰；

5. 不得在飞机和机场附近使用。

RE Directive

Hereby, Renesas Electronics Corporation declares that the radio equipment type RTK0EN0001D01001BZ is in compliance with Directive 2014/53/EU.

The full text of the EU declaration of conformity and the conformity risk assessment report are shown from the next page.



Renesas Electronics Corporation
3-2-24, Toyosu, Koto-ku, Tokyo, 135-0061, Japan

EU DECLARATION of CONFORMITY (DoC)

This declaration of conformity is issued under the sole responsibility of the manufacturer:

Name: Renesas Electronics Corporation
Address: 3-2-24 Toyosu Koto-ku Tokyo 135-0061 Japan

We declare that the DoC is issued under our sole responsibility and belongs to the following product.

Object of the declaration:

Product Name	RL78/G1D Evaluation Board
Model Name	RTK0EN0001D01001BZ
Batch	N/A
Serial Number	N/A
Software Name	Bluetooth low energy protocol stack, Beacon stack
Software Ver.	Bluetooth low energy protocol stack is V1.10, V1.11, V1.20, and V1.21. Beacon stack is V1.00, V2.00, and V.2.10.
Accessories	N/A



The object of the declaration described above is in conformity with the relevant Union harmonization legislation:

Radio Equipment (RE) Directive (2014/53/EU)

The following harmonized standards and technical specifications have been applied:

Health & Safety
(Article 3.1(a)): EN 62368-1:2014(Second Edition)
EN 62479: 2010
EN 62311: 2008

EMC
(Article 3.1(b)): EN 301 489-1 V2.1.1
EN 301 489-17 V3.1.1

Radio Spectrum
(Article 3.2): EN 300 328 V2.2.2

Signed for and on behalf of:

Japan

Place of Issue:

April 9, 2021

Date of Issue:

Awanish

Awanish Mishra
Director
IoT Platform Business Division
IoT and Infrastructure Business Unit
Renesas Electronics Corporation

Revision History	RL78/G1D Evaluation Board User's Manual
------------------	---

Rev.	Date	Description	
		Page	Summary
1.00	Mar. 27, 2015	—	First Edition issued
1.10	June. 1, 2015	13	Append a CAUTION about static electricity accumulation avoidance.
		20	Appendix B. Conformity Assessment Described.
1.20	Sep. 1, 2015	15	Circuit diagram update (resistor R3 append)
1.30	Dec. 1, 2015	8	Figure 4-1: Changed the RL78/G1D module image data.
		21	China SRRC compliance notation added.
1.40	Sep. 1, 2016	17	Revised the circuit diagram of the extension board to RL78/G1D version.
		22	Replaced the DoC of the R&TTE Directive. (Article 3.2 Spectrum: EN 300 328 V1.8.1 → V1.9.1)
1.50	Jun. 8, 2017	Contents	Correction of specification name of "Usage Notes of Evaluation Board".
		22	Replaced the DoC of R&TTE directive with the DoC of RE directive. Added the conformity risk assessment report.
1.60	Feb. 1, 2019	5	Table 3-1: Corrected mistake of evaluation board type name of table title. R0K3ZBTM9D000BR → RTK0EN0001D01001BZ
1.70	May.28.21	22	Replaced the DoC of the RE Directive. (Article 3.2 Spectrum: EN 300 328 V2.1.1 → V2.2.2) Deleted the conformity risk assessment report.

RL78/G1D Evaluation Board User's Manual

Publication Date:	Rev.1.10	June.01,15
	Rev.1.20	Sep.01,15
	Rev.1.30	Dec.01,15
	Rev.1.40	Sep.01,16
	Rev.1.50	Jun.08,17
	Rev.1.60	Feb.01,19
	Rev.1.70	May.28.21

Published by: Renesas Electronics Corporation

RL78/G1D Group