

RL78/G23-64p Fast Prototyping Board

User's Manual

16-Bit Single-Chip Microcontrollers

RL78 Family

All information contained in these materials, including products and product specifications, represents information on the product at the time of publication and is subject to change by Renesas Electronics Corp. without notice. Please review the latest information published by Renesas Electronics Corp. through various means, including the Renesas Electronics Corp. website (<https://www.renesas.com>).

Notice

1. Descriptions of circuits, software and other related information in this document are provided only to illustrate the operation of semiconductor products and application examples. You are fully responsible for the incorporation or any other use of the circuits, software, and information in the design of your product or system. Renesas Electronics disclaims any and all liability for any losses and damages incurred by you or third parties arising from the use of these circuits, software, or information.
2. Renesas Electronics hereby expressly disclaims any warranties against and liability for infringement or any other claims involving patents, copyrights, or other intellectual property rights of third parties, by or arising from the use of Renesas Electronics products or technical information described in this document, including but not limited to, the product data, drawings, charts, programs, algorithms, and application examples.
3. No license, express, implied or otherwise, is granted hereby under any patents, copyrights or other intellectual property rights of Renesas Electronics or others.
4. You shall be responsible for determining what licenses are required from any third parties, and obtaining such licenses for the lawful import, export, manufacture, sales, utilization, distribution or other disposal of any products incorporating Renesas Electronics products, if required.
5. You shall not alter, modify, copy, or reverse engineer any Renesas Electronics product, whether in whole or in part. Renesas Electronics disclaims any and all liability for any losses or damages incurred by you or third parties arising from such alteration, modification, copying or reverse engineering.
6. Renesas Electronics products are classified according to the following two quality grades: "Standard" and "High Quality". The intended applications for each Renesas Electronics product depends on the product's quality grade, as indicated below.

"Standard": Computers; office equipment; communications equipment; test and measurement equipment; audio and visual equipment; home electronic appliances; machine tools; personal electronic equipment; industrial robots; etc.

"High Quality": Transportation equipment (automobiles, trains, ships, etc.); traffic control (traffic lights); large-scale communication equipment; key financial terminal systems; safety control equipment; etc.

Unless expressly designated as a high reliability product or a product for harsh environments in a Renesas Electronics data sheet or other Renesas Electronics document, Renesas Electronics products are not intended or authorized for use in products or systems that may pose a direct threat to human life or bodily injury (artificial life support devices or systems; surgical implantations; etc.), or may cause serious property damage (space system; undersea repeaters; nuclear power control systems; aircraft control systems; key plant systems; military equipment; etc.). Renesas Electronics disclaims any and all liability for any damages or losses incurred by you or any third parties arising from the use of any Renesas Electronics product that is inconsistent with any Renesas Electronics data sheet, user's manual or other Renesas Electronics document.

7. No semiconductor product is absolutely secure. Notwithstanding any security measures or features that may be implemented in Renesas Electronics hardware or software products, Renesas Electronics shall have absolutely no liability arising out of any vulnerability or security breach, including but not limited to any unauthorized access to or use of a Renesas Electronics product or a system that uses a Renesas Electronics product. RENESAS ELECTRONICS DOES NOT WARRANT OR GUARANTEE THAT RENESAS ELECTRONICS PRODUCTS, OR ANY SYSTEMS CREATED USING RENESAS ELECTRONICS PRODUCTS WILL BE INVULNERABLE OR FREE FROM CORRUPTION, ATTACK, VIRUSES, INTERFERENCE, HACKING, DATA LOSS OR THEFT, OR OTHER SECURITY INTRUSION ("Vulnerability Issues"). RENESAS ELECTRONICS DISCLAIMS ANY AND ALL RESPONSIBILITY OR LIABILITY ARISING FROM OR RELATED TO ANY VULNERABILITY ISSUES. FURTHERMORE, TO THE EXTENT PERMITTED BY APPLICABLE LAW, RENESAS ELECTRONICS DISCLAIMS ANY AND ALL WARRANTIES, EXPRESS OR IMPLIED, WITH RESPECT TO THIS DOCUMENT AND ANY RELATED OR ACCOMPANYING SOFTWARE OR HARDWARE, INCLUDING BUT NOT LIMITED TO THE IMPLIED WARRANTIES OF MERCHANTABILITY, OR FITNESS FOR A PARTICULAR PURPOSE.
8. When using Renesas Electronics products, refer to the latest product information (data sheets, user's manuals, application notes, "General Notes for Handling and Using Semiconductor Devices" in the reliability handbook, etc.), and ensure that usage conditions are within the ranges specified by Renesas Electronics with respect to maximum ratings, operating power supply voltage range, heat dissipation characteristics, installation, etc. Renesas Electronics disclaims any and all liability for any malfunctions, failure or accident arising out of the use of Renesas Electronics products outside of such specified ranges.
9. Although Renesas Electronics endeavors to improve the quality and reliability of Renesas Electronics products, semiconductor products have specific characteristics, such as the occurrence of failure at a certain rate and malfunctions under certain use conditions. Unless designated as a high reliability product or a product for harsh environments in a Renesas Electronics data sheet or other Renesas Electronics document, Renesas Electronics products are not subject to radiation resistance design. You are responsible for implementing safety measures to guard against the possibility of bodily injury, injury or damage caused by fire, and/or danger to the public in the event of a failure or malfunction of Renesas Electronics products, such as safety design for hardware and software, including but not limited to redundancy, fire control and malfunction prevention, appropriate treatment for aging degradation or any other appropriate measures. Because the evaluation of microcomputer software alone is very difficult and impractical, you are responsible for evaluating the safety of the final products or systems manufactured by you.
10. Please contact a Renesas Electronics sales office for details as to environmental matters such as the environmental compatibility of each Renesas Electronics product. You are responsible for carefully and sufficiently investigating applicable laws and regulations that regulate the inclusion or use of controlled substances, including without limitation, the EU RoHS Directive, and using Renesas Electronics products in compliance with all these applicable laws and regulations. Renesas Electronics disclaims any and all liability for damages or losses occurring as a result of your noncompliance with applicable laws and regulations.
11. Renesas Electronics products and technologies shall not be used for or incorporated into any products or systems whose manufacture, use, or sale is prohibited under any applicable domestic or foreign laws or regulations. You shall comply with any applicable export control laws and regulations promulgated and administered by the governments of any countries asserting jurisdiction over the parties or transactions.
12. It is the responsibility of the buyer or distributor of Renesas Electronics products, or any other party who distributes, disposes of, or otherwise sells or transfers the product to a third party, to notify such third party in advance of the contents and conditions set forth in this document.
13. This document shall not be reprinted, reproduced or duplicated in any form, in whole or in part, without prior written consent of Renesas Electronics.
14. Please contact a Renesas Electronics sales office if you have any questions regarding the information contained in this document or Renesas Electronics products.

(Note1) "Renesas Electronics" as used in this document means Renesas Electronics Corporation and also includes its directly or indirectly controlled subsidiaries.

(Note2) "Renesas Electronics product(s)" means any product developed or manufactured by or for Renesas Electronics.

(Rev.5.0-1 October 2020)

Corporate Headquarters

TOYOSU FORESIA, 3-2-24 Toyosu,
Koto-ku, Tokyo 135-0061, Japan

www.renesas.com

Trademarks

Renesas and the Renesas logo are trademarks of Renesas Electronics Corporation. All trademarks and registered trademarks are the property of their respective owners.

Contact information

For further information on a product, technology, the most up-to-date version of a document, or your nearest sales office, please visit:

www.renesas.com/contact/.

General Precautions in the Handling of Microprocessing Unit and Microcontroller Unit Products

The following usage notes are applicable to all Microprocessing unit and Microcontroller unit products from Renesas. For detailed usage notes on the products covered by this document, refer to the relevant sections of the document as well as any technical updates that have been issued for the products.

1. Precaution against Electrostatic Discharge (ESD)

A strong electrical field, when exposed to a CMOS device, can cause destruction of the gate oxide and ultimately degrade the device operation. Steps must be taken to stop the generation of static electricity as much as possible, and quickly dissipate it when it occurs. Environmental control must be adequate. When it is dry, a humidifier should be used. This is recommended to avoid using insulators that can easily build up static electricity. Semiconductor devices must be stored and transported in an anti-static container, static shielding bag or conductive material. All test and measurement tools including work benches and floors must be grounded. The operator must also be grounded using a wrist strap. Semiconductor devices must not be touched with bare hands. Similar precautions must be taken for printed circuit boards with mounted semiconductor devices.

2. Processing at power-on

The state of the product is undefined at the time when power is supplied. The states of internal circuits in the LSI are indeterminate and the states of register settings and pins are undefined at the time when power is supplied. In a finished product where the reset signal is applied to the external reset pin, the states of pins are not guaranteed from the time when power is supplied until the reset process is completed. In a similar way, the states of pins in a product that is reset by an on-chip power-on reset function are not guaranteed from the time when power is supplied until the power reaches the level at which resetting is specified.

3. Input of signal during power-off state

Do not input signals or an I/O pull-up power supply while the device is powered off. The current injection that results from input of such a signal or I/O pull-up power supply may cause malfunction and the abnormal current that passes in the device at this time may cause degradation of internal elements. Follow the guideline for input signal during power-off state as described in your product documentation.

4. Handling of unused pins

Handle unused pins in accordance with the directions given under handling of unused pins in the manual. The input pins of CMOS products are generally in the high-impedance state. In operation with an unused pin in the open-circuit state, extra electromagnetic noise is induced in the vicinity of the LSI, an associated shoot-through current flows internally, and malfunctions occur due to the false recognition of the pin state as an input signal become possible.

5. Clock signals

After applying a reset, only release the reset line after the operating clock signal becomes stable. When switching the clock signal during program execution, wait until the target clock signal is stabilized. When the clock signal is generated with an external resonator or from an external oscillator during a reset, ensure that the reset line is only released after full stabilization of the clock signal. Additionally, when switching to a clock signal produced with an external resonator or by an external oscillator while program execution is in progress, wait until the target clock signal is stable.

6. Voltage application waveform at input pin

Waveform distortion due to input noise or a reflected wave may cause malfunction. If the input of the CMOS device stays in the area between V_{IL} (Max.) and V_{IH} (Min.) due to noise, for example, the device may malfunction. Take care to prevent chattering noise from entering the device when the input level is fixed, and also in the transition period when the input level passes through the area between V_{IL} (Max.) and V_{IH} (Min.).

7. Prohibition of access to reserved addresses

Access to reserved addresses is prohibited. The reserved addresses are provided for possible future expansion of functions. Do not access these addresses as the correct operation of the LSI is not guaranteed.

8. Differences between products

Before changing from one product to another, for example to a product with a different part number, confirm that the change will not lead to problems. The characteristics of a microprocessing unit or microcontroller unit products in the same group but having a different part number might differ in terms of internal memory capacity, layout pattern, and other factors, which can affect the ranges of electrical characteristics, such as characteristic values, operating margins, immunity to noise, and amount of radiated noise. When changing to a product with a different part number, implement a system-evaluation test for the given product.

Renesas RL78/G23-64p Fast Prototyping Board Disclaimer

By using this RL78/G23-64p Fast Prototyping Board, the User accepts the following terms, which are in addition to, and control in the event of disagreement, with Renesas' General Terms and Conditions available at [renesas.com/legal-notices](https://www.renesas.com/legal-notices).

The RL78/G23-64p Fast Prototyping Board is not guaranteed to be error free, and the entire risk as to the results and performance of the RL78/G23-64p Fast Prototyping Board is assumed by the User. The RL78/G23-64p Fast Prototyping Board is provided by Renesas on an "as is" basis without warranty of any kind whether express or implied, including but not limited to the implied warranties of good workmanship, fitness for a particular purpose, title, merchantability, and non-infringement of intellectual property rights. Renesas expressly disclaims any implied warranty.

Renesas does not consider the RL78/G23-64p Fast Prototyping Board to be a finished product and therefore the RL78/G23-64p Fast Prototyping Board may not comply with some requirements applicable to finished products, including, but not limited to recycling, restricted substances and electromagnetic compatibility regulations. Refer to Certifications section, for information about certifications and compliance information for the RL78/G23-64p Fast Prototyping Board. It is the kit User's responsibility to make sure the kit meets any local requirements applicable to their region.

Renesas or its affiliates shall in no event be liable for any loss of profit, loss of data, loss of contract, loss of business, damage to reputation or goodwill, any economic loss, any reprogramming or recall costs (whether the foregoing losses are direct or indirect) nor shall Renesas or its affiliates be liable for any other direct or indirect special, incidental or consequential damages arising out of or in relation to the use of this RL78/G23-64p Fast Prototyping Board, even if Renesas or its affiliates have been advised of the possibility of such damages.

Renesas has used reasonable care in preparing the information included in this document, but Renesas does not warrant that such information is error free nor does Renesas guarantee an exact match for every application or parameter to part numbers designated by other vendors listed herein. The information provided in this document is intended solely to enable the use of Renesas products. No express or implied license to any intellectual property right is granted by this document or in connection with the sale of Renesas products. Renesas reserves the right to make changes to specifications and product descriptions at any time without notice. Renesas assumes no liability for any damages incurred by you resulting from errors in or omissions from the information included herein. Renesas cannot verify, and assumes no liability for, the accuracy of information available on another company's website.

Precautions

This Fast Prototyping Board is only intended for use in a laboratory environment under ambient temperature and humidity conditions. A safe separation distance should be used between this and any sensitive equipment. Its use outside the laboratory, classroom, study area, or similar such area invalidates conformity with the protection requirements of the Electromagnetic Compatibility Directive and could lead to prosecution.

The product generates, uses, and can radiate radio frequency energy and may cause harmful interference to radio communications. There is no guarantee that interference will not occur in a particular installation. If this equipment causes harmful interference to radio or television reception, which can be determined by turning the equipment off or on, you are encouraged to try to correct the interference by one or more of the following measures:

- Ensure attached cables do not lie across the equipment.
- Reorient the receiving antenna.
- Increase the distance between the equipment and the receiver.
- Connect the equipment into an outlet on a circuit different from that which the receiver is connected.
- Power down the equipment when not in use.
- Consult the dealer or an experienced radio/TV technician for help.

Note: It is recommended that wherever possible shielded interface cables are used.

The product is potentially susceptible to certain EMC phenomena. To mitigate against them it is recommended that the following measures be undertaken:

- The user is advised that mobile phones should not be used within 10 m of the product when in use.
- The user is advised to take ESD precautions when handling the equipment.

The Evaluation Kit does not represent an ideal reference design for an end product and does not fulfil the regulatory standards for an end product.

Proprietary Notice

All text, graphics, photographs, trademarks, logos, artwork, and computer code, collectively known as content, contained in this document is owned, controlled, or licensed by or to Renesas, and is protected by trade dress, copyright, patent and trademark laws, and other intellectual property rights and unfair competition laws. Except as expressly provided herein, no part of this document or content may be copied, reproduced, republished, posted, publicly displayed, encoded, translated, transmitted, or distributed in any other medium for publication or distribution or for any commercial enterprise, without prior written consent from Renesas.

"Pmod™" is the trademark of Digilent Inc. The Pmod Interface Specification is the property of Digilent Inc. For more information on the use of the Pmod trademark, please see our [Pmod License Agreement](#) page.

Arduino® is a trademark of Arduino SA.

Other brands and names mentioned in this document may be the trademarks or registered trademarks of their respective holders.

How to Use This Manual

1. Purpose and Target Readers

This manual is designed to provide the user with an understanding of the basic specifications and correct usage of this product.

The target users are those who will be using it in evaluating MCUs and debugging programs.

The target readers of this manual require basic knowledge regarding the facilities of MCUs and debuggers.

Particular attention should be paid to the precautionary notes when using the manual. These notes occur within the body of the text, at the end of each section, and in the Handling Precautions section.

The revision history summarizes the locations of revisions and additions. It does not list all revisions. Refer to the text of the manual for details.

The following documents apply to the RL78/G23-64p Fast Prototyping Board. Be sure to refer to the latest versions of these documents.

Document Type	Description	Document Title	Document No.
User's manual	Hardware specifications	RL78/G23-64p Fast Prototyping Board User's Manual	R20UT4814EJ (this manual)
Circuit schematics	Circuit schematics	RL78/G23-64p Fast Prototyping Board Circuit Schematics	R20UT4931EJ
Parts list	Parts list	RL78/G23-64p Fast Prototyping Board BOM LIST	R12TU0120EJ
User's manual for the hardware	Hardware specifications (pin assignments, memory maps, peripheral function specifications, electrical characteristics, timing charts) and descriptions of operation	RL78/G23 User's Manual: Hardware	R01UH0896EJ
Application note	Usage of the RL78 debugging functions using the serial port	RL78 Debugging Functions Using the Serial Port	R20AN0632EJ

2. List of Abbreviations and Acronyms

Abbreviation	Full Form
Arduino™ UNO	Connectors compatible with the Arduino™ UNO R3 board are mounted on the fast prototyping board.
CPU	Central Processing Unit
DIP	Dual In-line Package
DNF	Do Not Fit
Grove	A connector that is compatible with Grove modules can be mounted on the fast prototyping board.
IDE	Integrated Development Environment
IRQ	Interrupt Request
HOCO	High-Speed On-Chip Oscillator
LOCO	Low-Speed On-Chip Oscillator
LED	Light Emitting Diode
MCU	Micro-controller Unit
n/a (NA)	Not applicable
n/c (NC)	Not connected
PC	Personal Computer
RAM	Random Access Memory
RFP	Renesas Flash Programmer
ROM	Read Only Memory
SPI	Serial Peripheral Interface
USB	Universal Serial Bus
TPU	Timer Pulse Unit
UART	Universal Asynchronous Receiver/Transmitter
WDT	Watchdog timer

All trademarks and registered trademarks are the property of their respective owners.

Table of Contents

1. Overview.....	1
1.1 Purpose.....	1
1.2 Features.....	1
1.3 Preparation	1
1.3.1 Installing the e ² studio IDE	2
1.3.2 Installing the CS+ IDE	2
1.4 Board Specification Table	3
1.5 Block Diagram.....	4
2. Board Layout	5
3. Parts Layout	6
4. Operating Environment.....	7
5. User Circuits	8
5.1 Evaluation MCU	8
5.2 USB Connector	8
5.3 Power LED.....	8
5.4 User LEDs.....	8
5.5 Arduino™ Connectors	9
5.6 MCU Headers	11
5.7 Grove Connector.....	13
5.8 Clock	13
5.9 Reset Switch	14
5.10 User Switch.....	14
5.11 USB-to-Serial Converter	14
5.12 USB-to-Serial Converter Reset Header.....	15
5.13 Power-Supply Selection Header	16
5.14 External Power Supply.....	18
5.15 DC-Jack Power Supply	18
5.16 Current Measurement Header	19
5.17 Separate Pattern for VDD and EVDD	20
5.18 Pattern for Cutting the I/O Power Supply for the USB-to-Serial Converter	20
5.19 Emulator Connector	21
6. Handling Precautions.....	23
6.1 Power to be Supplied.....	23
6.2 Remodeling the Board	23
6.3 Power Supplies and Usage Conditions	25
7. Developing Code	27
7.1 Using the e ² studio	27
7.2 Using CS+	28
8. Certifications	29
8.1 EMC/EMI Standards	29
8.2 Material Selection, Waste, Recycling and Disposal Standards	30
8.3 Safety Standards	30
9. Design and Manufacturing Information	31

10. Website and Support32

1. Overview

This user's manual describes the RL78/G23-64p Fast Prototyping Board (RTK7RLG230CLG000BJ) (hereinafter referred to as "this product").

1.1 Purpose

This product is an evaluation tool for a Renesas MCU. This user's manual describes the hardware specifications, ways of setting switches, and the basic setup procedure.

1.2 Features

- Programming of the Renesas MCU
- Debugging of user code
- User circuits for switches and LEDs

1.3 Preparation

- Watch the video on "Getting Started with Fast Prototyping Board for RL78 Family".
<https://www.renesas.com/video/getting-started-fast-prototyping-board-rl78-family>
- Install the integrated development environment (IDE) and required software on the host PC.
<https://www.renesas.com/development-tools>
- Prepare a micro-USB cable for data transfer.
- Refer to the following Web page and prepare the E2 emulator if required.
<https://www.renesas.com/e2>
- Refer to the following Web page and prepare the E2 emulator Lite if required.
<https://www.renesas.com/e2lite>

1.3.1 Installing the e² studio IDE

For details on the procedure for installation, watch the video on “e² studio Quick Start Guide Video for RL78 Family - Installation”.

<https://www.renesas.com/software-tool/rl78-software-tool-course>

1. Download the installer for the latest version of the e² studio from the following Web page.
<https://www.renesas.com/software-tool/e-studio>
2. Unzip the downloaded zip file and run the installer file.
3. Select “RL78” for [Device Families].
4. Confirm that the latest version of Renesas CCRL has been selected as the compiler.
5. Select the [I accept the terms of the Software Agreements] checkbox and then click on the [Install] button.
6. When the software produces an installer window in the middle of installation, proceed with installation according to the instructions from the wizard.
7. After installation has finished, click on the [OK] button.

1.3.2 Installing the CS+ IDE

1. Download the installer for the latest version of CS+ for CC from the following Web page.
<https://www.renesas.com/software-tool/cs>
2. Unzip the downloaded zip file and run the installer file.
3. Click on [Begin CS+ Startup].
4. Confirm that [Tools for RL78 family] has been selected.
5. After installation has finished, click on the [OK] button.

1.4 Board Specification Table

Table 1-1 shows the board specifications.

Table 1-1 Board Specification Table

Item	Specification
Evaluation MCU (RL78/G23 with 64 pins)	Part No.: R7F100GLG2DFB
	Package: 64-pin LQFP
	On-chip memory: 128-KB ROM, 16-KB RAM, 8-KB data flash memory
Board size	53.34 mm x 68.58 mm
Power-supply voltage	VDD: 1.6 V to 5.5 V (EVDD is the same voltage as VDD.)
Power-supply circuit*2	USB connector: VBUS (5 V) or 3.3 V (default)
	External power supply: 1.6 V to 5.5 V
	DC jack: 7 V to 12 V
	E2 emulator or E2 emulator Lite
Current drawn	Max. 200 mA
Main clock*1	OSC1: Crystal oscillator (surface-mount technology (SMT)) for the main system clock
	OSC2: Crystal oscillator or ceramic resonator (lead type) for the main system clock
Sub-clock	OSC3: Crystal oscillator (SMT) for the sub-clock
Push switches	Reset switch x 1
	User switch x 1
LEDs	Power indicator: green x 1
	User: green x 2
USB connector	Connector: Micro USB Type-B
Arduino™ connectors	Connectors: 6 pins x 1, 8 pins x 2, 10 pins x 1 The interfaces are compatible with the Arduino™ UNO R3 board.
MCU headers*1	Headers: 19 pins x 1, 16 pins x 1
USB-to-serial converter	Used as the interface with the RL78 COM port debug tool. FT232RQ from FTDI x 1
USB-to-serial converter reset header	Header: 2 pins x 1 (open-circuit by default)
Current measurement headers*1	Headers: 2 pins x 2
Power-supply selection header*2	Header: 3 pins x 1
Emulator connector*1	14-pin connector for connecting an E2 emulator or E2 emulator Lite
Grove connector*1	Interface for Grove modules

Notes: 1. This part is not mounted.

2. The intended source of power for the evaluation MCU on the board as shipped is VBUS (5 V). Setting a jumper is required if power is to be supplied from other sources. For details, refer to Chapter 5, User Circuits.

1.5 Block Diagram

Figure 1-1 shows the block diagram of this product.

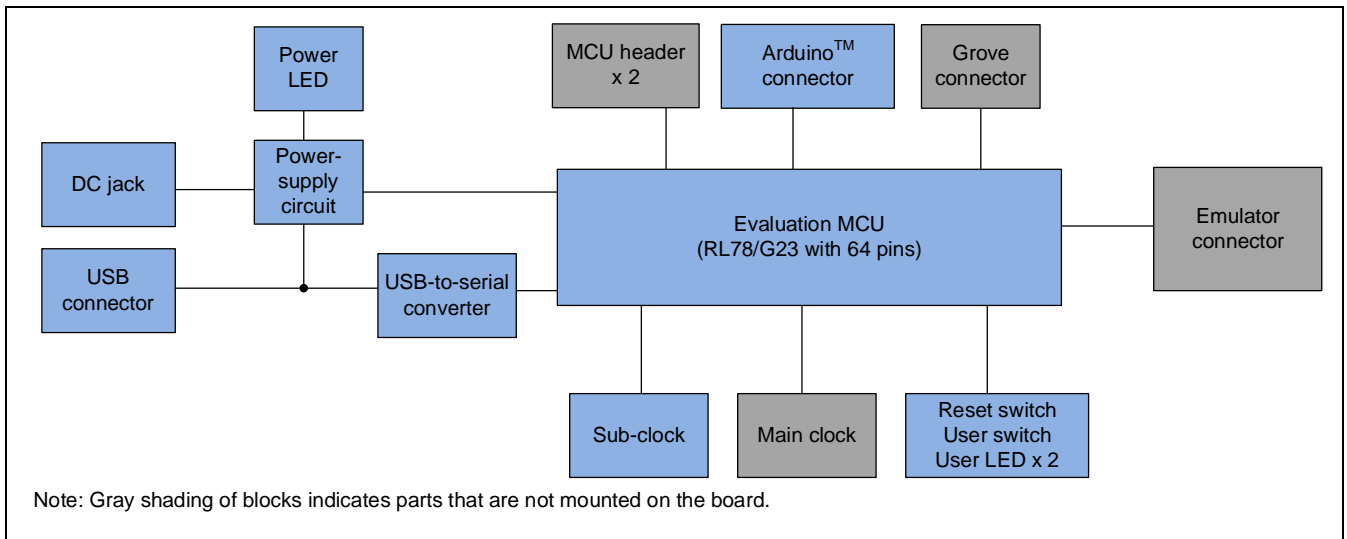

Figure 1-1 Block Diagram

2. Board Layout

Figure 2-1 shows the external appearance of the top side of this product.

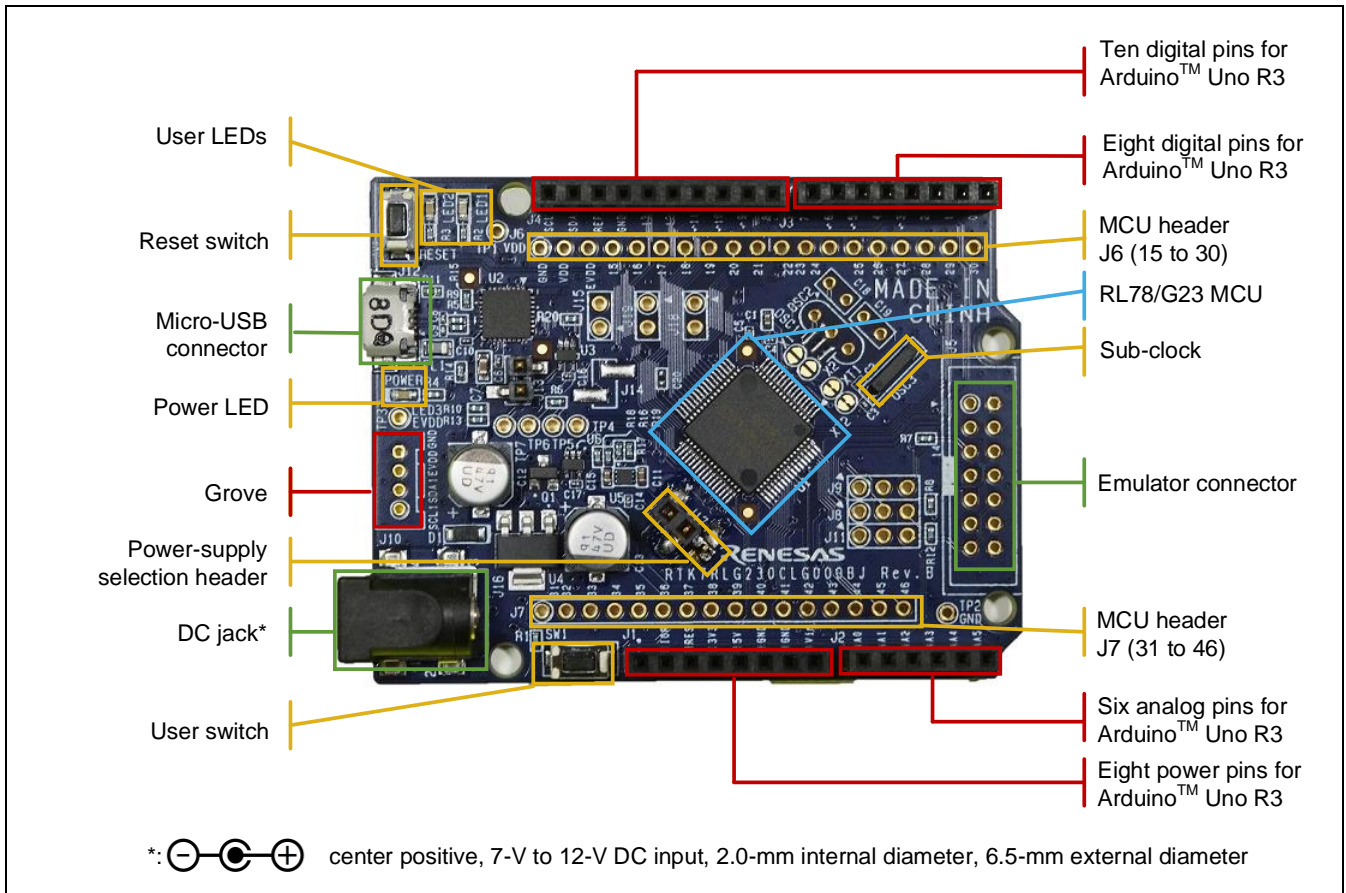

Figure 2-1 Board Layout (Top Side)

3. Parts Layout

Figure 3-1 shows the parts layout of this product.

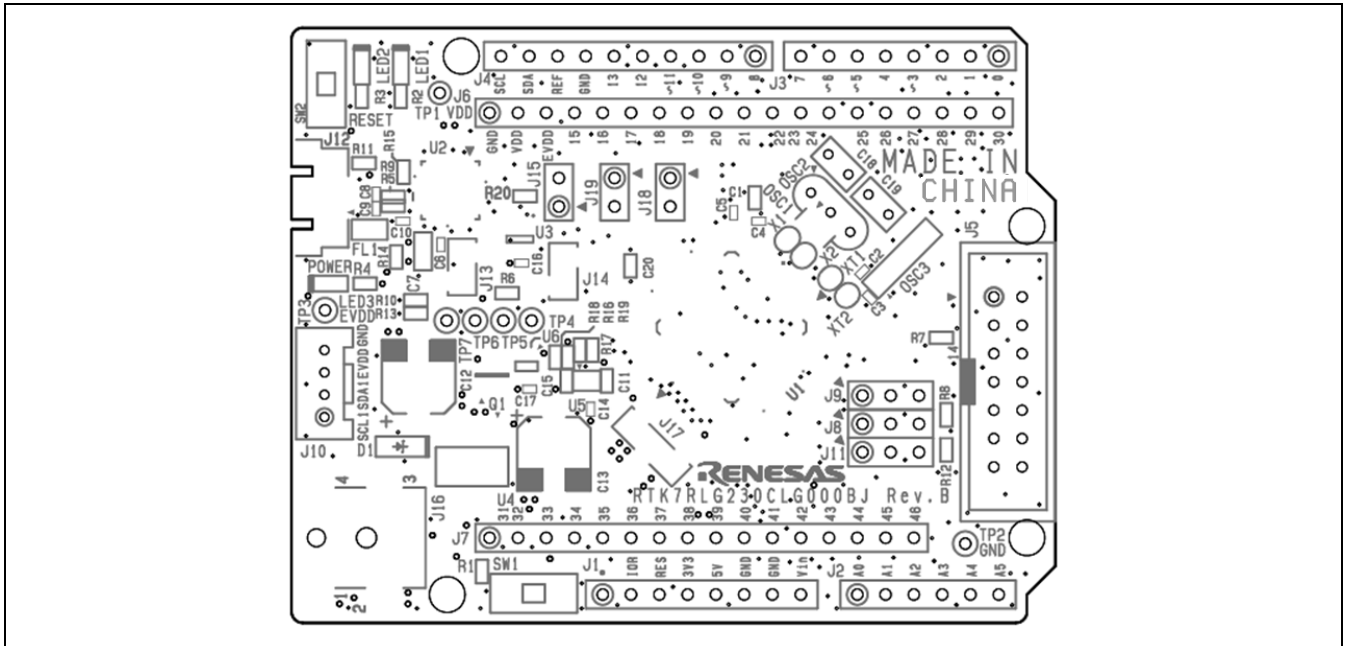

Figure 3-1 Parts Layout

Figure 3-2 shows the external dimensions of this product.

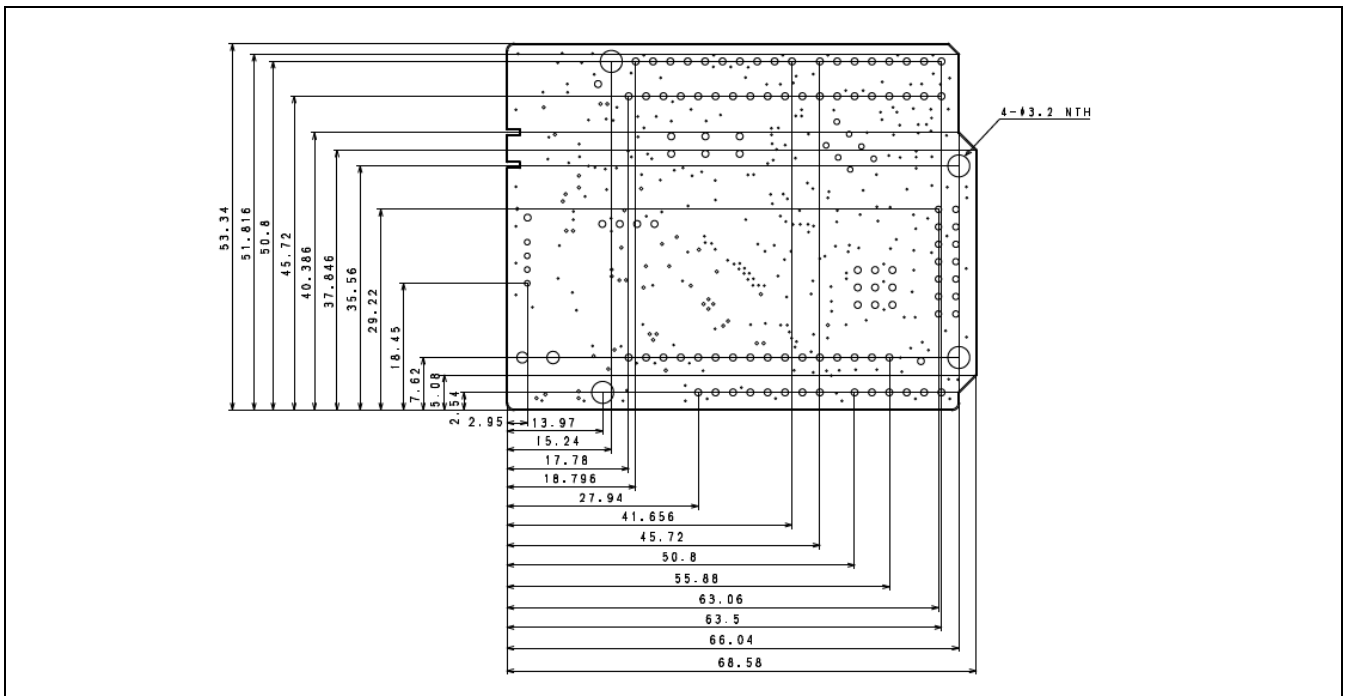

Figure 3-2 External Dimensions

4. Operating Environment

Figure 4-1 shows the operating environment of this product. Install the IDE on the host PC.

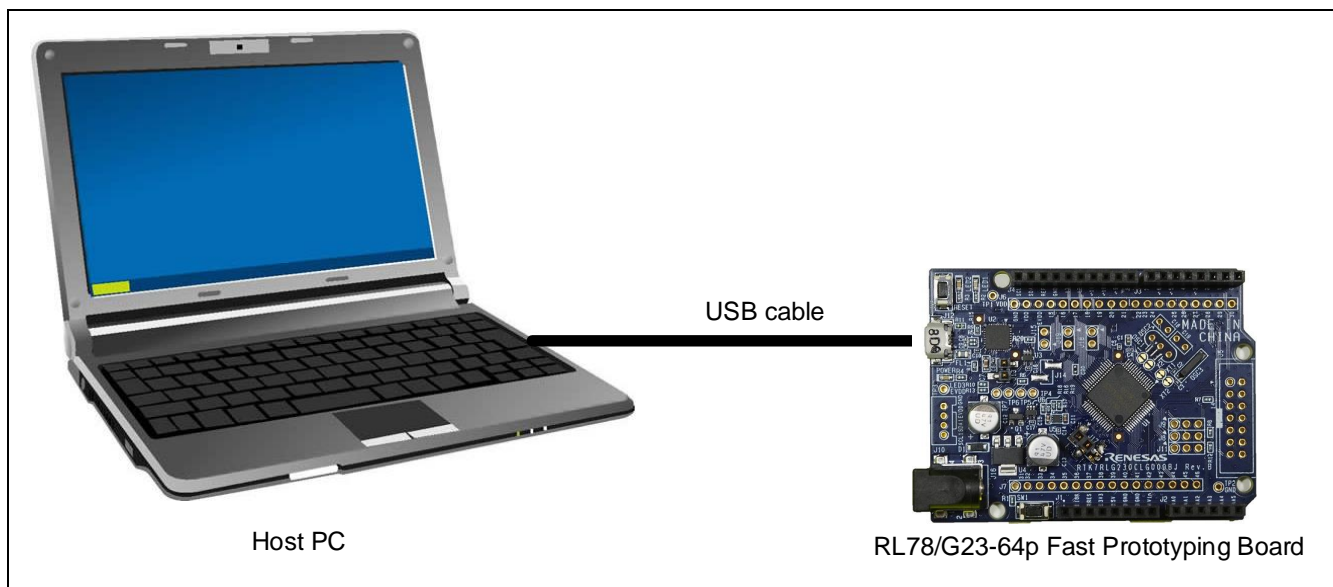

Figure 4-1 Operating Environment

5. User Circuits

5.1 Evaluation MCU

The specifications for the power supply, system clock, and reset of the evaluation MCU (RL78/G23 with 64 pins) at the time of shipment are as follows.

- Power supply: 5 V (VBUS) supplied from the USB (including the analog power supply)
- System clock: Operation with an on-chip oscillator
- Reset: Directed by the reset switch or IDE

5.2 USB Connector

The connector shape is micro-USB Type-B. It serves as a power-supply input and an interface for communications with the RL78 COM port debug tool (through USB-to-serial conversion). Connect the USB connector to the computer by a USB cable. If the power supply on the host side is on, the power is supplied to this product at the same time as connection of the cable.

Note: The package does not include a USB cable. Do not connect a USB cable while the emulator is supplying power.

5.3 Power LED

While the power LED is illuminated, VDD power is being supplied. The LED is green.

Note: The LED may not be illuminated when the power supply voltage is 2.2 V or lower.

5.4 User LEDs

The optional user LEDs can be used for any purpose. LED1 and LED2 are mounted on the board and are respectively connected to the following ports. The LEDs are green.

- LED1: Pin 36, connected to port P53
- LED2: Pin 35, connected to port P52

Note: The LED may not be illuminated when the power supply voltage is 2.2 V or lower.

5.5 Arduino™ Connectors

The specification of the Arduino™ connectors is on the assumption that Arduino™ shields are to be connectable. However, we do not guarantee connection to all types of Arduino™ shield. Confirm the specifications of this product against any Arduino™ shield you intend to use.

Figure 5-1 and Table 5-1 show the pin assignments of the Arduino™ connectors.

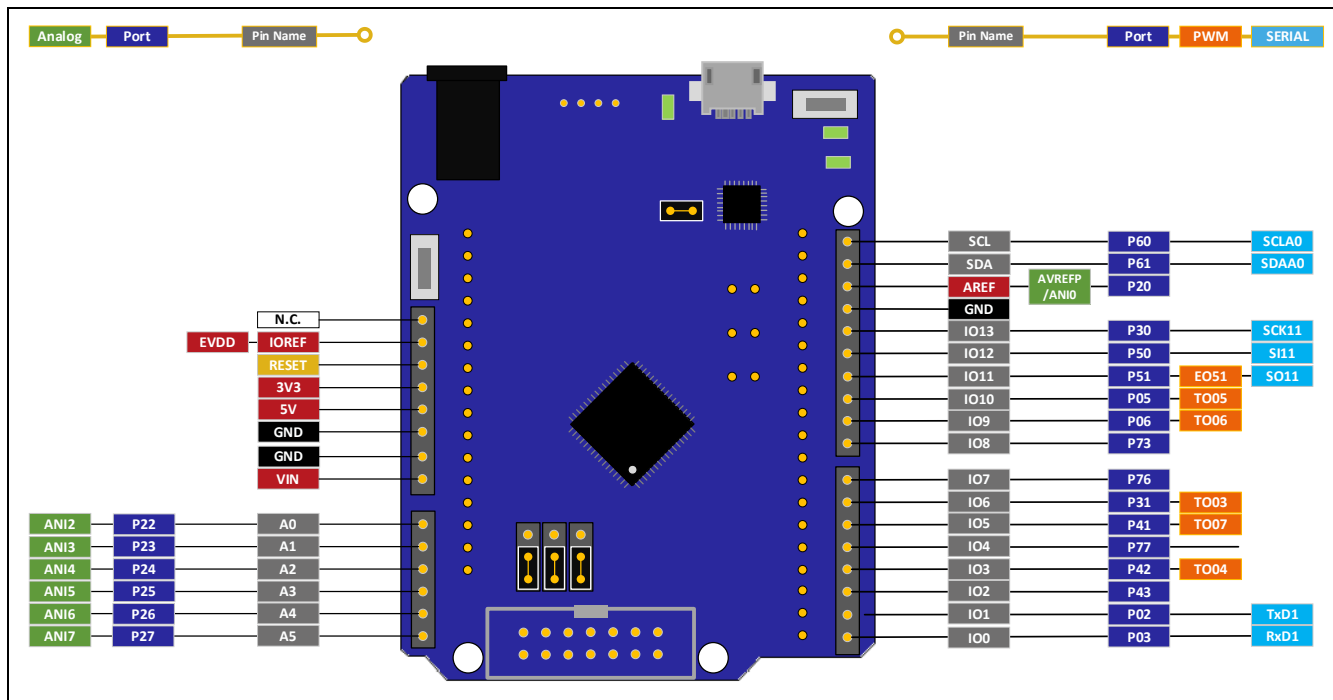

Figure 5-1 Pin Assignments of the Arduino™ Connectors

Table 5-1 Pin Assignments of the Arduino™ Connectors

Part No. in the Circuit Schematics	Name of Arduino™ Signal*2	RL78/G23 with 64 Pins						
		Pin	Power Supply	Port	Analog	PWM	Serial	Others
J1-1	N.C.	-	-	-	-	-	-	-
J1-2	IOREF	16	EVDD	-	-	-	-	-
J1-3	RESET	6	-	-	-	-	-	RESET
J1-4	3V3	-	-	-	-	-	-	-
J1-5	5V	-	-	-	-	-	-	-
J1-6	GND	14	VSS	-	-	-	-	-
J1-7	GND	14	VSS	-	-	-	-	-
J1-8	VIN	-	-	-	-	-	-	-
J2-1	A0	54	-	P22	ANI2	-	-	ANO0/TS20/EI22
J2-2	A1	53	-	P23	ANI3	-	-	ANO1/TS21/EI23
J2-3	A2	52	-	P24	ANI4	-	-	TS22
J2-4	A3	51	-	P25	ANI5	-	-	TS23
J2-5	A4	50	-	P26	ANI6	-	-	TS24
J2-6	A5	49	-	P27	ANI7	-	-	TS25
J3-1	IO0	59	-	P03	ANI16	-	RxD1 /SI10/SDA10	TS29
J3-2	IO1	60	-	P02	ANI17	-	TxD1 /SO10	TS28
J3-3	IO2	2	-	P43	-	-	-	CLKA1
J3-4	IO~3	3	-	P42	-	TO04	TxDA1-	TI04
J3-5	IO4	22	-	P77	-	-	-	TS09/KR7/INTP11
J3-6	IO~5	4	-	P41	-	TO07	RxDA1	TI07
J3-7	IO~6	21	-	P31	-	TO03	-	TS01/EI31/TI03/INTP4
J3-8	IO7	23	-	P76	-	-	-	TS08/KR6/INTP10
J4-1	IO8	26	-	P73	-	-	SO01	TS05/KR3
J4-2	IO~9	30	-	P06	-	TO06	-	TS11/TI06/CLKA0
J4-3	IO~10	31	-	P05	-	TO05	-	TS10/TI05
J4-4	IO~11	34	-	P51	-	EO51*1	SO11	EI51/CCD02/INTP2
J4-5	IO12	33	-	P50	-	-	SI11 /SDA11	TS00/EI50/EO50 /CCD03/INTP1
J4-6	IO13	32	-	P30	-	-	SCK11 /SCL11	VCOUT0/TSCAP /EI30/INTP3 /RTC1HZ
J4-7	GND	14	VSS	GND	-	-	-	-
J4-8	ADREF	56	-	P20*3	AVREFP /ANI0	-	-	EI20 VDD
J4-9	SDA	18	-	P61	-	-	SDAA0	EO61/CCD05
J4-10	SCL	17	-	P60	-	-	SCLA0	EO60/CCD04

Notes: 1. The TO02 (P17) timer output is available by using the event-link facility.

2. "x" in IOx and IO~x means a pin number for the Arduino™ IDE. For more information about Arduino IDE please refer to the following URL: <https://github.com/renesas/Arduino/wiki/>

3. P20 is connected to VDD by default. When P20 is disconnected from VDD, cut the given pattern for cutting [AVREFP].

5.6 MCU Headers

The MCU headers are provided as through holes; J6 includes the headers for a total of 19 pins and J7 includes the headers for a total of 16 pins. The pin headers have a pitch of 2.54 mm and the evaluation MCU is connected to the through holes for the headers.

Note that a multiplexed pin function of IO14 is for use as pin 5 of the emulator connector (J5). Table 5-2 and Table 5-3 show the pin assignments of the MCU headers.

Table 5-2 Pin Assignments of the MCU Headers (1)

Part No. in the Circuit Schematics	Name of Arduino™ Signal*1	RL78/G23 with 64 Pins						
		Pin	Power Supply	Port	Analog	PWM	Serial	Others
J5-5	IO14	5	-	P40	-	-	-	TOOL0
J6-15	-	13,14	VSS	-	-	-	-	-
J6-16	-	15	VDD	-	-	-	-	-
J6-17	-	16	EVDD	-	-	-	-	-
J6-18	IO15	35	-	P52	-	-	-	<u>LED2</u>
J6-19	IO16	36	-	P53	-	-	-	<u>LED1</u>
J6-20	IO17	37	-	P54	-	-	-	-
J6-21	IO18	38	-	P55	-	-	-	-
J6-22	IO19	29	-	P70	-	-	SCK21/SCL21	TS02/RIN0/KR0
J6-23	IO20	28	-	P71	-	-	SI21/SDA21/RxDA0	TS03/KR1
J6-24	IO21	27	-	P72	-	-	SO21/TxDA0	TS04/KR2
J6-25	IO22	25	-	P74	-	-	SI01/SDA01	TS06/KR4/INTP8
J6-26	IO23	24	-	P75	-	-	SCK01/SCL01	TS07/KR5/INTP9
J6-27	IO24	11	-	P121	-	-	-	VBAT/EI121
J6-28	IO25	10	-	P122	-	-	-	EXCLK/EI122
J6-29	IO26	9	-	P137	-	-	-	EI137/INTP0 <u>SW1</u>
J6-30	IO27	8	-	P123 *2	-	-	-	-
J6-31	IO28	7	-	P124 *3	-	-	-	EXCLKS
J6-32	IO29	1	-	P120	ANI19	-	-	IVCMP1/EI120
J6-33	IO30	58	-	P04	-	-	SCK10/SCL10	-

- Notes: 1. "x" in IOx means a pin number for the Arduino™ IDE. For more information about Arduino IDE please refer to the following URL: <https://github.com/renesas/Arduino/wiki/>
2. P123 is connected to the XT1 sub-clock by default. When P123 is to be used as a port pin, cut the pattern for cutting [XT1] and short-circuit the short-circuit pad [P123].
3. P124 is connected to the XT2 sub-clock by default. When P124 is to be used as a port pin, cut the pattern for cutting [XT2] and short-circuit the short-circuit pad [P124].

Table 5-3 Pin Assignments of the MCU Headers (2)

Part No. in the Circuit Schematics	Name of Arduino™ Signal*1	RL78/G23 with 64 Pins						
		Pin	Power Supply	Port	Analog	PWM	Serial	Others
J7-34	IO31	39	-	P17	-	TO02	-	EO17/CCD01/TI02-
J7-35	IO32	40	-	P16	-	TO01	-	EO16/CCD00/TI01/INTP5
J7-36	IO33	41	-	P15	-	-	SCK20/SCL20	EO15
J7-37	IO34	42	-	P14	-	-	RxD2/SI20/ SDA20	VCOUT1/EO14
J7-38	IO35	43	-	P13	-	-	TxD2/SO20	IVREF1/EO13
J7-39	IO36	44	-	P12	-	-	SO00/TxD0	EI12/EO12
J7-40	IO37	45	-	P11	-	-	SI00/RxD0/ SDA00	EI11/EO11
J7-41	IO38	46	-	P10	-	-	SCK00/SCL00	EI10/EO10
J7-42	IO39	47	-	P146	-	-	-	-
J7-43	IO40	48	-	P147	ANI18	-	-	IVCMP0/EI147
J7-44	IO41	55	-	P21 *4	ANI1/ AVREFM	-	-	EI21
J7-45	IO42	57	-	P130	-	-	-	-
J7-46	IO43	61	-	P01	-	TO00	-	TS27/EI01/EO01
J7-47	IO44	62	-	P00	-	-	-	TS26/EI00/TI00
J7-48	IO45	63	-	P141	-	-	-	PCLBUZ1/INTP7
J7-49	IO46	64	-	P140	-	-	-	PCLBUZ0/INTP6

Note: P21 is connected to GND by default. When P21 is to be disconnected from GND, cut the given pattern for cutting [AVREFM].

5.7 Grove Connector

This connector (J10) is assumed to be connected to Grove modules (through I2C). If a connector is mounted, however, connection to all Grove modules (through I2C) is not guaranteed. Use this connector after having confirmed the specifications of this product and Grove modules (through I2C) you intend to use.

Figure 5-2 and Table 5-4 show the pin assignments of the Grove connector (the connector is not mounted).

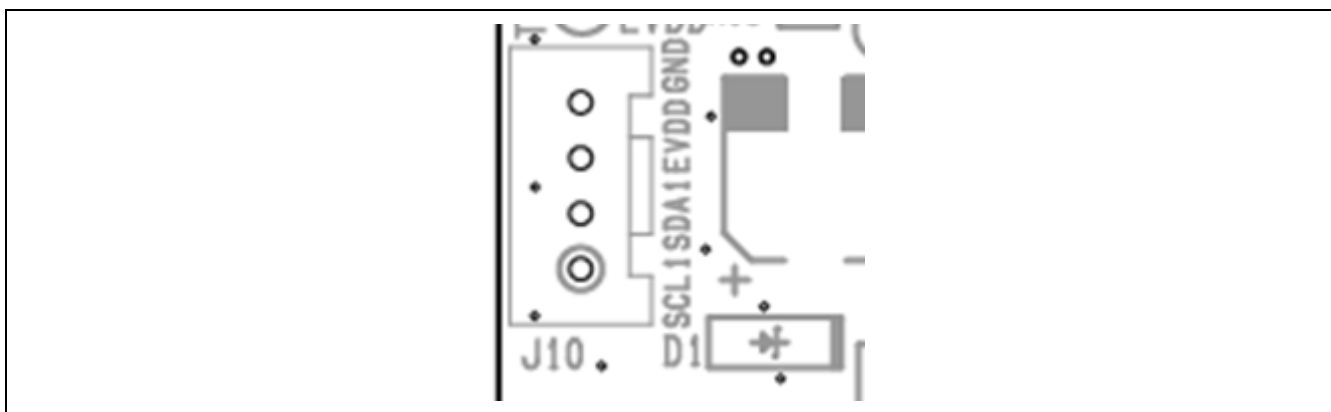

Figure 5-2 Pin Assignments of the Grove Connector

Table 5-4 Pin Assignments of the Grove Connector

Part No. in the Circuit Schematics	RL78/G23 with 64 Pins			
	Pin	Power Supply	Port	I2C
J10-1	19	-	P62	SCLA1
J10-2	20	-	P63	SDAA1
J10-3	-	EVDD	-	-
J10-4	-	GND	-	-

5.8 Clock

Clock circuits are provided to handle the clock sources for the evaluation MCU. For details on the specifications of the evaluation MCU, refer to the RL78/G23 User's Manual: Hardware. For details on the clock circuit of this product, refer to the circuit schematics of the RL78/G23-64p Fast Prototyping Board. Table 5-5 shows the details of the clocks on the RL78/G23-64p Fast Prototyping Board.

Table 5-5 Details of Clocks

Clock	Function and Usage	State as Shipped	Frequency	Package for the oscillator
OSC1*	Crystal oscillator for the main system clock (e.g. CSTNE20M0V5 from Murata Manufacturing Co., Ltd.)	Not mounted	n/a	SMT
OSC2*	Crystal oscillator or ceramic resonator for the main system clock	Not mounted	n/a	Lead type
OSC3	Crystal oscillator for the sub-clock	Mounted	32.768 kHz	SMT

Note: Use the main system clock by cutting the patterns for cutting [P121] and [P122] and short-circuiting the short-circuit pads [X1] and [X2].

5.9 Reset Switch

Pressing the reset switch (SW2:RESET) applies a hardware reset to the evaluation MCU.

5.10 User Switch

An optional user switch (SW1) is mounted. It is connected to pin 9 of the evaluation MCU, which operates as pin function P137. The INTP0 interrupt is multiplexed on the same pin.

5.11 USB-to-Serial Converter

A USB-to-serial converter (FT232RQ) from FTDI is mounted on the board and is usable with the standard driver of Windows 10. For other operating systems, install the driver by downloading from the following Web site of FTDI. <https://www.ftdichip.com/> DRIVERS -> VCP Drivers

The USB-to-serial converter reset header (J13) is open-circuit; it is recognized as a COM port when the host PC is connected to this board via a USB cable.

As the interface with the RL78 COM port debug tool, the USB-to-serial converter enables debugging and programming of the evaluation MCU. Refer to Chapter 7, Developing Code. Note that the P40, P11, and P12 pins of the evaluation MCU are respectively occupied as the TOOL0, TOOLRxD, and TOOLTxD functions.

For the method of COM port debugging, refer to the application note, RL78 Debugging Functions Using the Serial Port (R20AN0632).

When the USB-to-serial converter is not used as the interface with the RL78 COM port debug tool, using the RxD0 and TxD0 functions of the P11 and P12 pins enables UART communications between the host PC and the evaluation MCU. The user needs to prepare the terminal software, such as TeraTerm.

5.12 USB-to-Serial Converter Reset Header

The USB-to-serial converter is placed in the forced reset state by short-circuiting its reset header (J13). If the evaluation MCU alone is to operate without the use of the RL78 COM port debug tool, place the USB-to-serial converter in the reset state. This allows the use of P11 (RxD0) and P12 (TxD0) for functions other than a UART, such as port pins, while a reset is being applied to the USB-to-serial converter. Even if P11 and P12 are to be used for functions other than a UART, such as port pins, the board must be connected to the host PC by using the USB cable. Figure 5-3 shows the position of the USB-to-serial converter reset header.

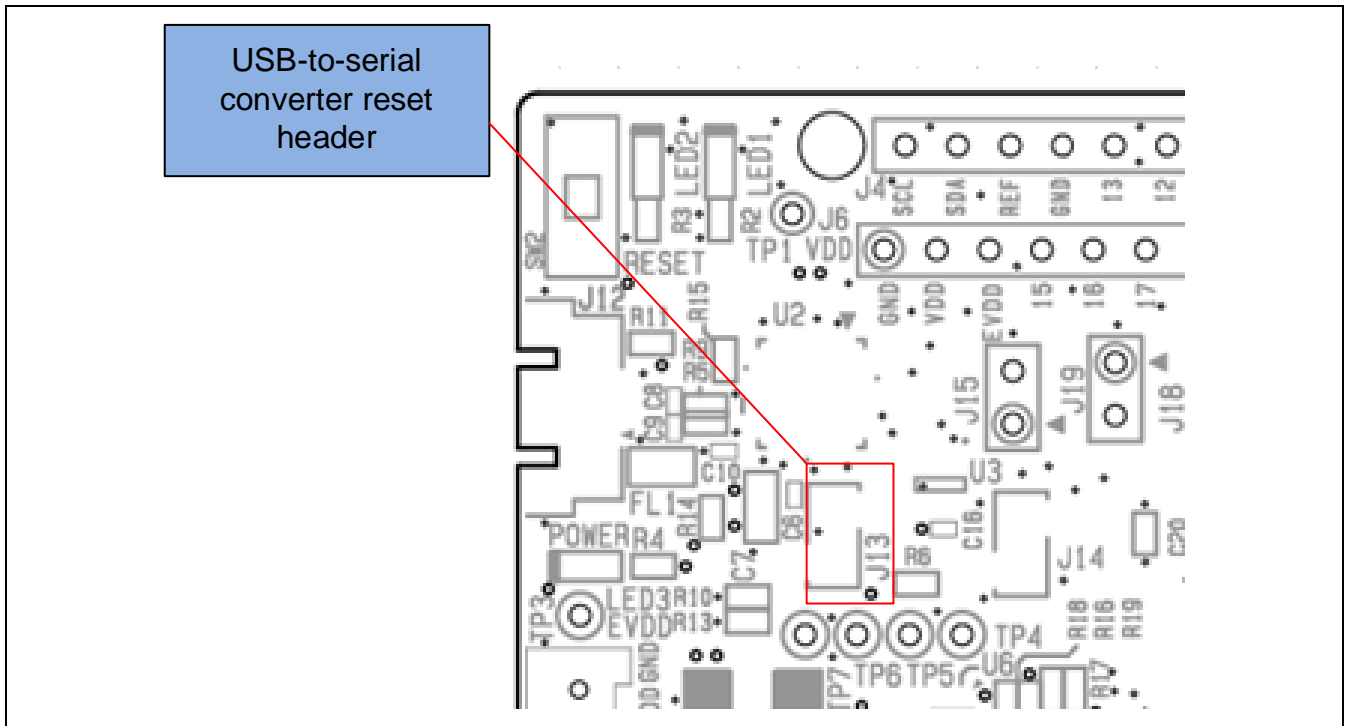

Figure 5-3 Position of the USB-to-Serial Converter Reset Header (Top Side)

5.13 Power-Supply Selection Header

The operating power (VDD) of the evaluation MCU can be set to 5 V or 3.3 V or to supply from the emulator or external power with the use of a header (J17). Only change the jumper setting of J17 while power is not being supplied.

- 1-2 of J17 being short-circuit selects a 5-V power supply. This is the default setting as shipped (Figure 5-4).
- 2-3 of J17 being short-circuit selects a 3.3-V power supply (Figure 5-5).
- J17 being open-circuit selects supply from the emulator or external power (Figure 5-6).

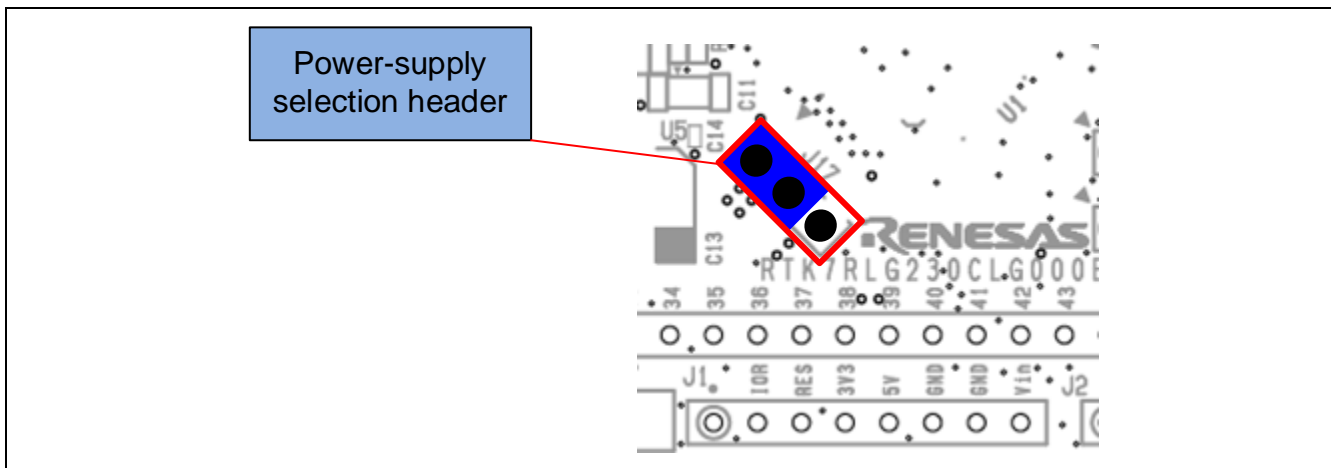

Figure 5-4 Setting of the Header to Select a 5-V Power Supply (Top Side)

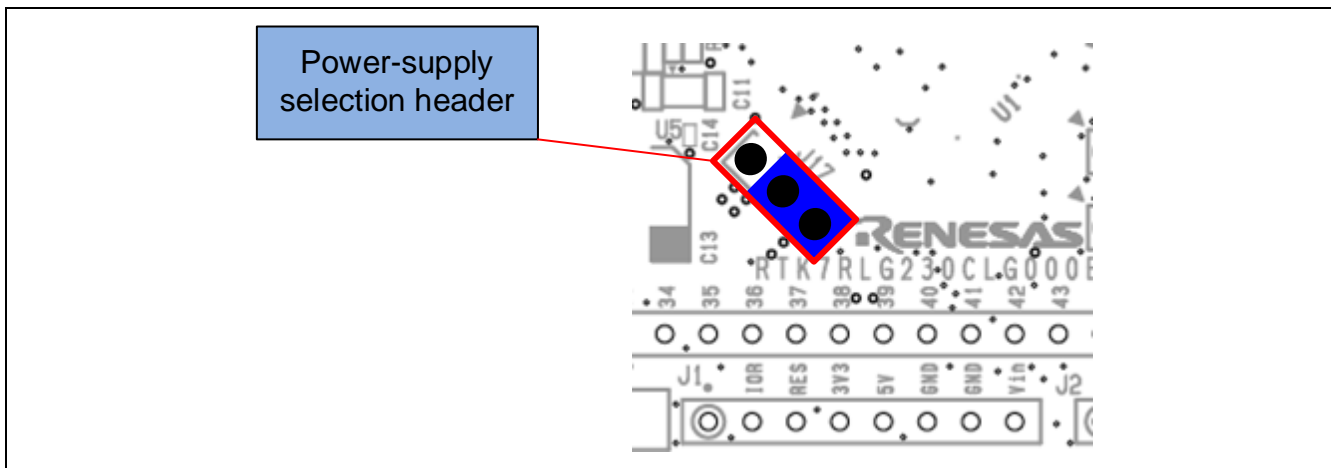

Figure 5-5 Setting of the Header to Select a 3.3-V Power Supply (Top Side)

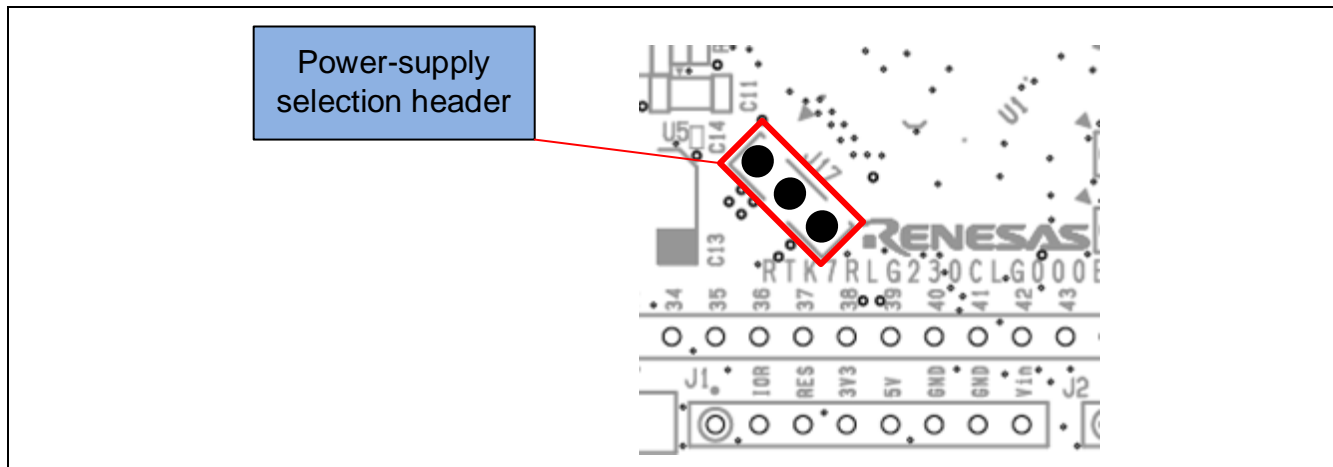

Figure 5-6 Setting of the Header to Select Supply from the Emulator or External Power (Top Side)

5.14 External Power Supply

When the evaluation MCU is to have a desired power-supply voltage, or when more current is required, use an external power supply. The usable voltages depend on the evaluation MCU.

Destinations for the connection of an external power supply:

- VDD side: pin J6-16 or TP1 on the MCU header
- GND side: pin J6-15 or TP2 on the MCU header

Figure 5-7 shows the positions of the external power supply.

When an external power supply is used, confirm that the I/O voltages for Arduino™ shields or Grove modules are correct.

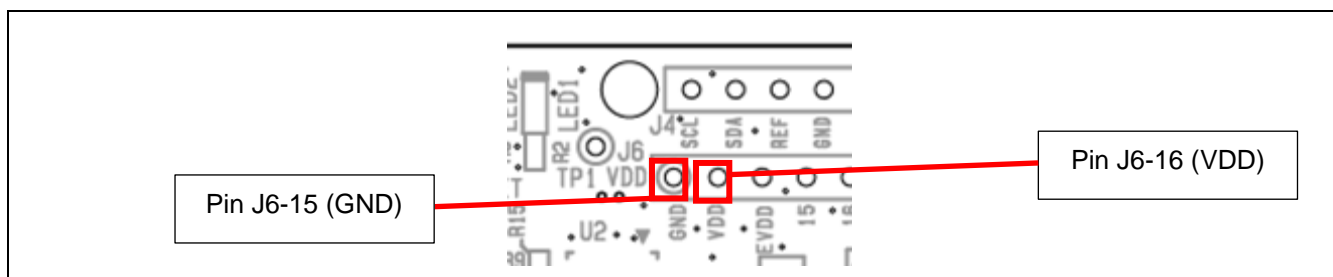

Figure 5-7 Positions of the Destinations for Connection of an External Power Supply (Top Side)

5.15 DC-Jack Power Supply

This product can also operate with an AC adapter (7 V to 12 V) connected to the DC jack (J16). The DC jack has center-positive polarity (⊖ ⊕), 2.0-mm internal diameter, and 6.5-mm external diameter (type number: KLDX-SMT2-0202-ATR from KYCON).

When this product is simultaneously connected to the DC jack and the USB cable, VBUS and the 5-V power supply are disconnected by an FET switch.

5.16 Current Measurement Header

This header (J18) is used to measure the current drawn by the evaluation MCU (J18 header components are not mounted). Connecting an ammeter to this product enables measurement of the current being drawn by the evaluation MCU. Take care to cut the given pattern for cutting (VDD) if this header is to be used. Figure 5-8 shows the positions of the current measurement header and pattern for cutting.

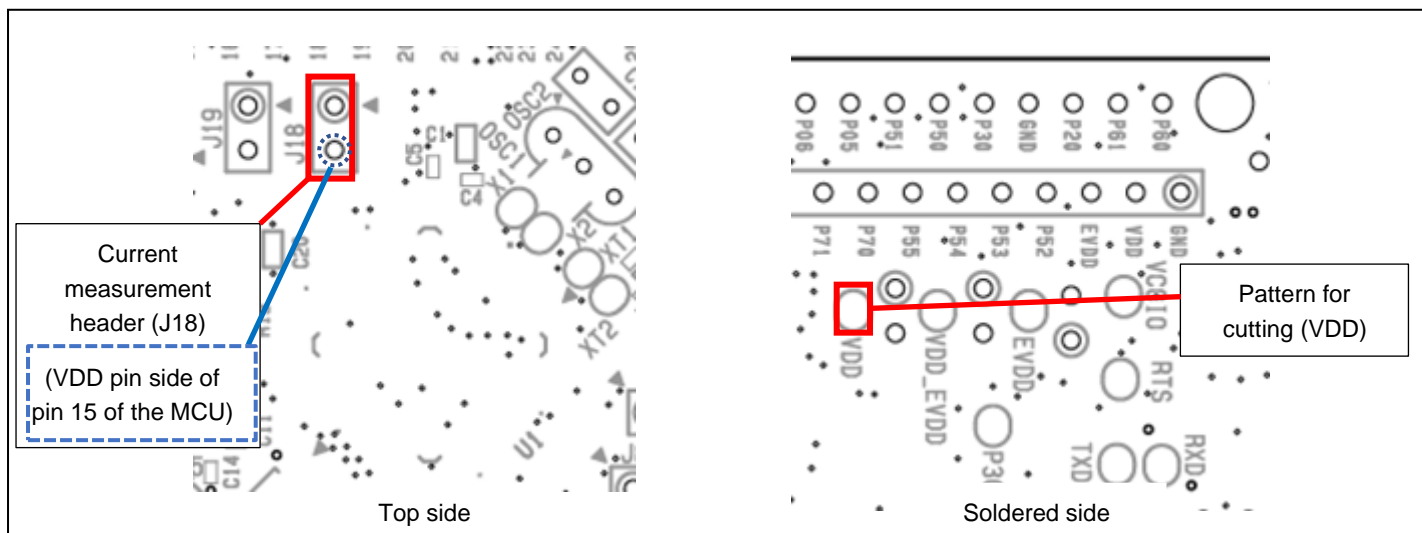

Figure 5-8 Positions of the Current Measurement Header (J18) and Pattern for Cutting (VDD)

Insert an ammeter between the sockets of the current measurement header (J18) to measure the current. Cut the pattern for cutting (VCCIO) (Figure 5-11) and turn down the LED to reduce the current drawn with an MCU other than the evaluation MCU.

When the current is to be measured with EVDD turned off and the MCU in a low-power state, cut the pattern for cutting (VDD_EVDD) (Figure 5-10) to separate VDD from EVDD.

Figure 5-9 is a block diagram of the power-supply lines related to the measurement of current drawn. For a block diagram of the power-supply circuit as a whole, refer to Figure 6-2.

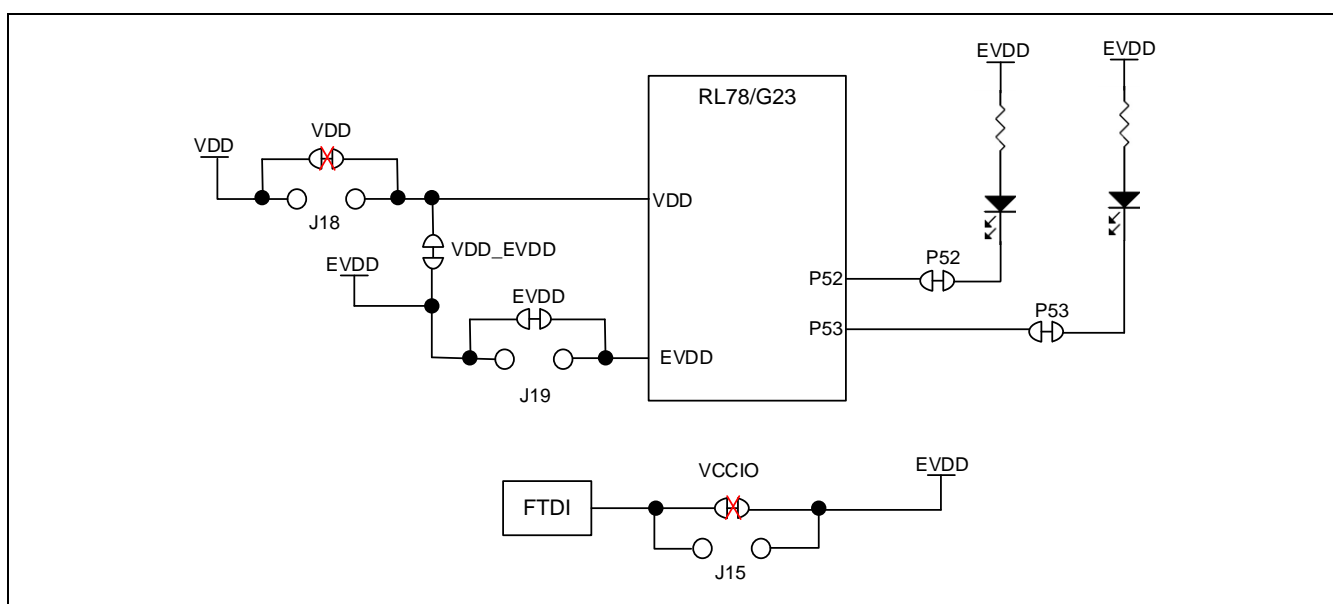

Figure 5-9 Block Diagram of the Headers Related to Current Measurement

5.17 Separate Pattern for VDD and EVDD

When VDD and EVDD are to be used with different potentials, cut the given pattern for cutting (VDD_EVDD). Figure 5-10 shows the position of the pattern for cutting.

Destination for the connection of an external power supply of EVDD to the source with a different potential:

- EVDD side: pin J6-17 or TP2 on the MCU header

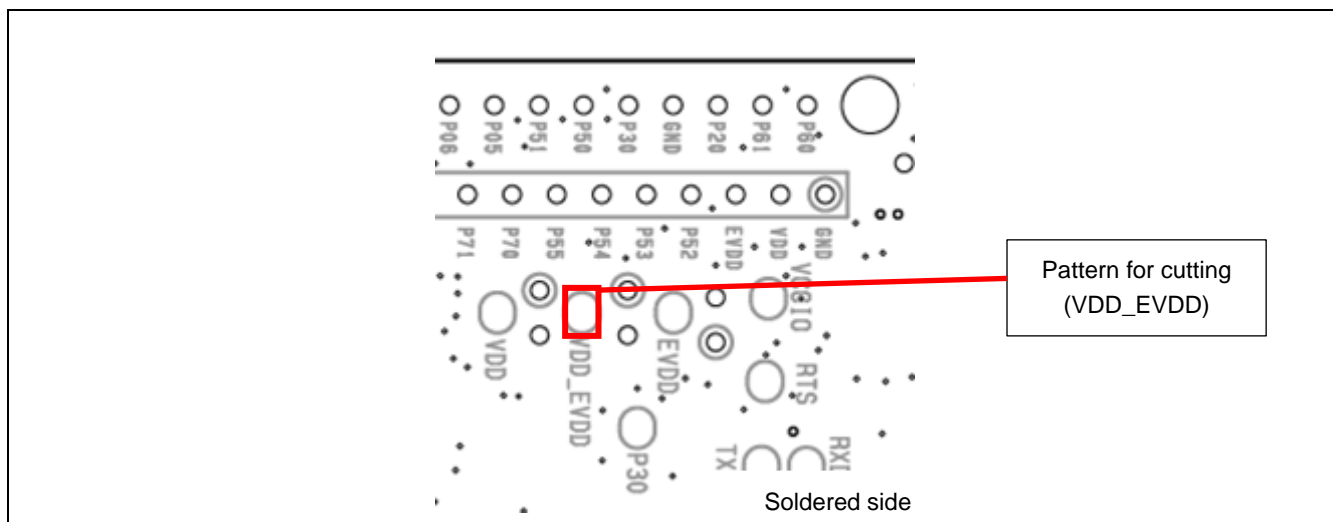

Figure 5-10 Position of the Pattern for Cutting (VDD_EVDD)

5.18 Pattern for Cutting the I/O Power Supply for the USB-to-Serial Converter

If you intend to use this board without connecting a USB connector, cut the given pattern for cutting (VCCIO). Figure 5-11 shows the position of the pattern for cutting. Also make the J15 header open-circuit (header components are not mounted).

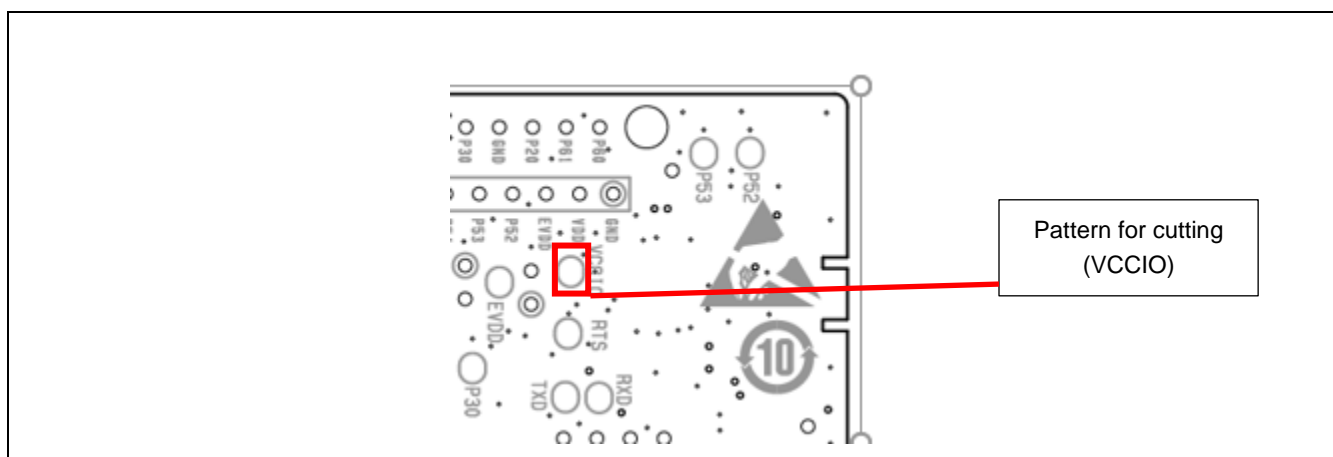

Figure 5-11 Position of the Pattern for Cutting (VCCIO)

5.19 Emulator Connector

This 14-pin connector (J5) is used to connect this product to an on-chip debugging E2 emulator or E2 emulator Lite, from Renesas Electronics, incorporating programming facilities (the connector is not mounted). The emulator is used for programming or debugging the evaluation MCU.

To use the emulator, make the following settings.

- J5: 14-pin connector must be mounted.
- J8, J9, and J11: pins 2-3 are short-circuit
- Pattern for cutting [TOOL0_USB]: cut
- Pattern for cutting [RESET]: cut
- Pattern for cutting [T_RESET]: cut

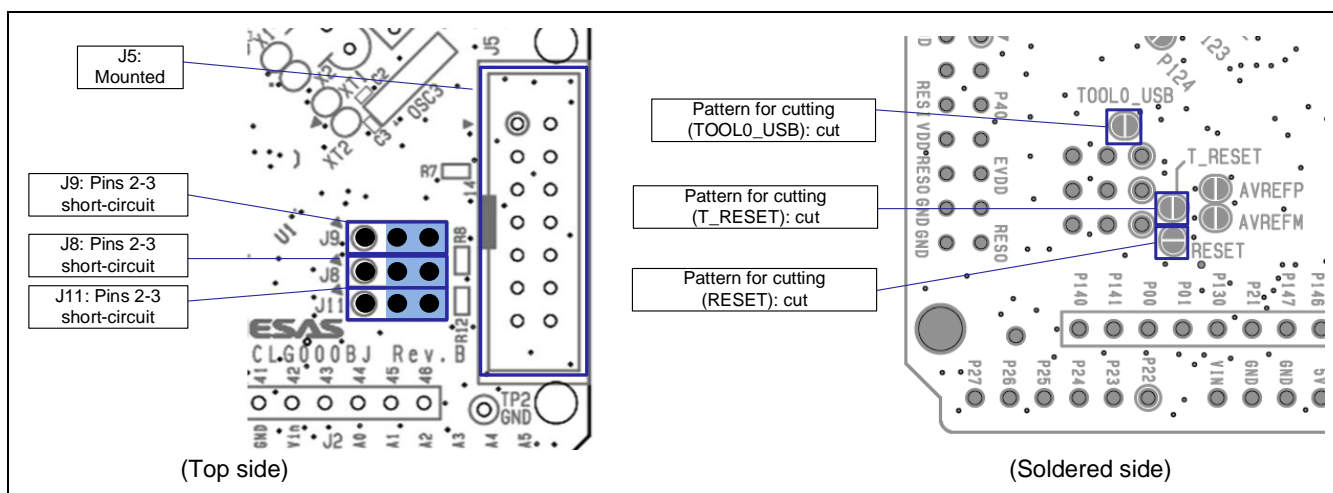

Figure 5-12 Settings for Use with the Emulator Connector

For the usage of the emulator, refer to the E1/E20/E2 Emulator, E2 emulator Lite Additional Document for User’s Manual (Notes on Connection of RL78) (R20UT1994).

After the changes to the circuit have been made to connect the emulator as described in the previous page, if you want to restore the settings to those for COM port debugging with the use of the USB-to-serial converter, make the following change of setting as follows.

- J8, J9, and J11: pins 1-2 are short-circuit
- J13: open-circuit

For the patterns for cutting that were cut on the previous page, solder need not to be applied.

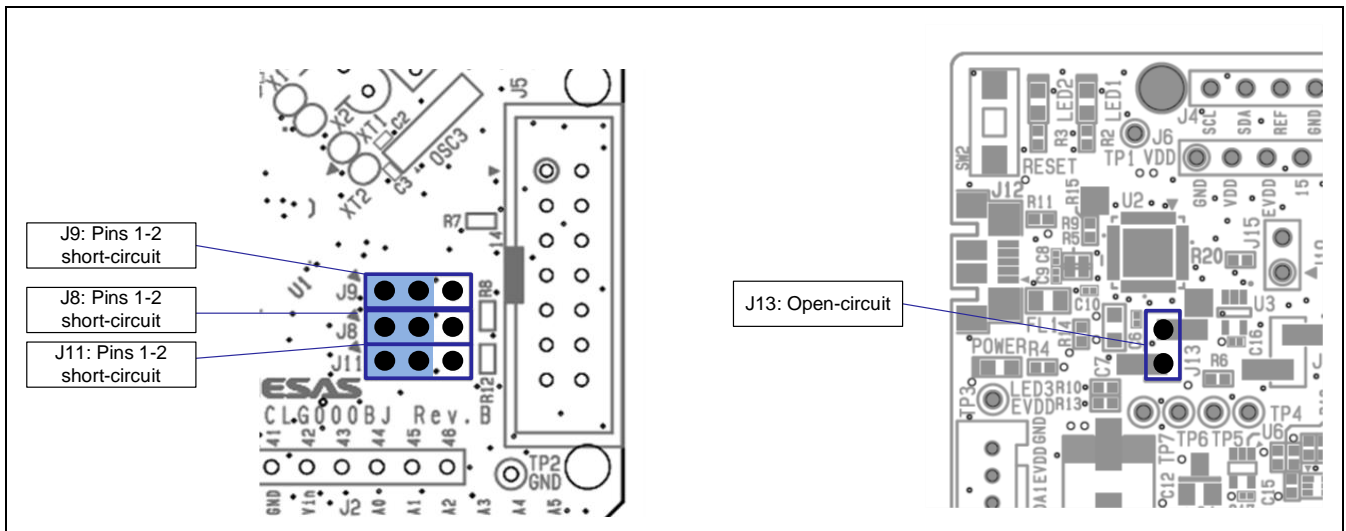

Figure 5-13 Settings for Use with COM Port Debugging (Top Side)

6. Handling Precautions

6.1 Power to be Supplied

When power is supplied to this product through the USB or DC jack, or from an emulator, note that the total current of VDD, EVDD, 5 V, and 3.3 V should not exceed the maximum current of 200 mA.

6.2 Remodeling the Board

Any modification of the board (including cutting the patterns for cutting) shall be conducted at the user’s own responsibility.

The following shows the settings of jumpers as shipped.

- J13: open-circuit
- J17: pins 1-2 are short-circuit

In this document, “short-circuit pads” refers to pairs of pads for short-circuiting by solder.

“Pattern for cutting” refers to a narrow signal pattern in the middle part between two short-circuit pads. When you cut the pattern for cutting, do not cut over the silkscreened frame of a white ellipse.

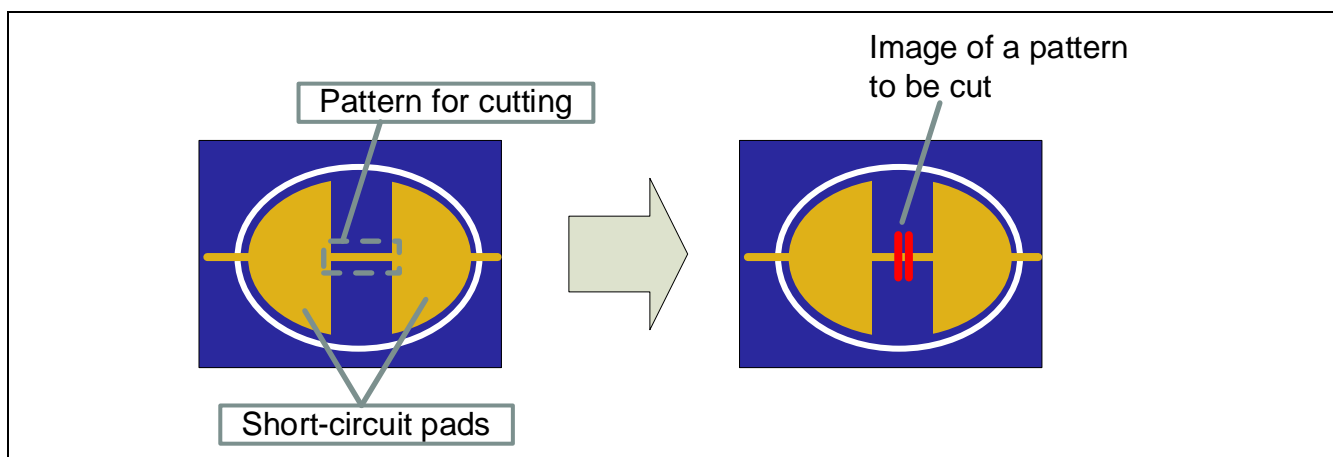
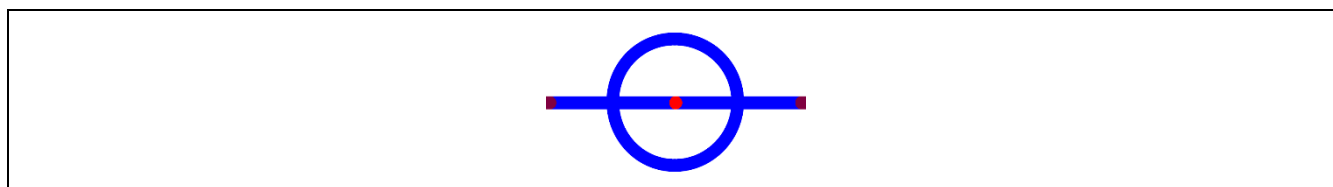

Figure 6-1 Pattern for Cutting and Short-circuit Pads

In some cases, a pattern for cutting may not be visible because it has been covered with coating of a resist. Also refer to the circuit schematics.

In the circuit schematics, the symbol below indicates that there is a pattern for cutting between short-circuit pads.



In the circuit schematics, the symbol below indicates that there are only short-circuit pads without any pattern for cutting.

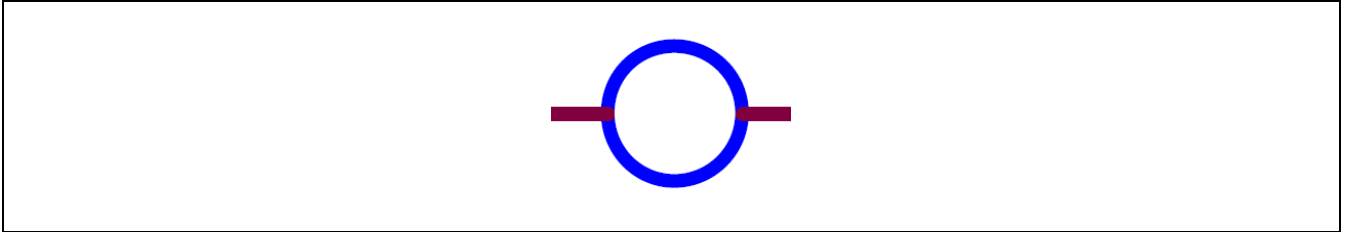

6.3 Power Supplies and Usage Conditions

Different power supplies can be selected. Table 6-1 shows the relationship between power-supply sources and usage conditions.

Figure 6-2 shows the block diagram of the power-supply circuit.

Table 6-1 Power-Supply Sources and Usage Conditions

Power-Supply Source	Usage Condition				
	Power supplied to the evaluation MCU	Use of Arduino™ shields*1	Use of Grove modules*1	Use of an emulator and IDE	Jumper setting*2
USB*4 (default)	5 V or 3.3 V	Possible	Possible	Possible*3	Not required • J17: 1-2 short-circuit: 5 V (default) Required • J17: 2-3 short-circuit: 3.3 V
DC jack (VIN)	5 V or 3.3 V	Possible	Possible	Possible*3	Not required • J17: 1-2 short-circuit: 5 V (default) Required • J17: 2-3 short-circuit: 3.3 V
External power supply	1.6 V or 5.5 V	Possible	Possible	Possible*3	Required • J17: open-circuit
Emulator	E2 Lite: 3.3 V E2: 1.8 V to 5.0 V	Possible*5	Possible	Possible	Required • J17: open-circuit

- Notes:
1. Connecting the RL78/G23-64p Fast Prototyping Board to an Arduino™ shield or a Grove module shall be conducted at the user's own responsibility and should only proceed after confirming the specifications of the power supply and interfaces. When an Arduino™ shield requires the supply of 5-V or 3.3-V power, connect the host PC to this board via the USB cable or use the DC jack.
 2. Requirements for modifications after shipment are stated in this column.
 3. Use the IDE in a state where power is being supplied from a source other than the emulator. The power supply voltage must be at least 1.8 V.
 4. If power to be supplied to this product other than via the USB, make J15 open-circuit and cut the pattern for cutting (VCCIO) (Figure 5-11).
 5. The shape of the shield may make using this product with the emulator difficult.

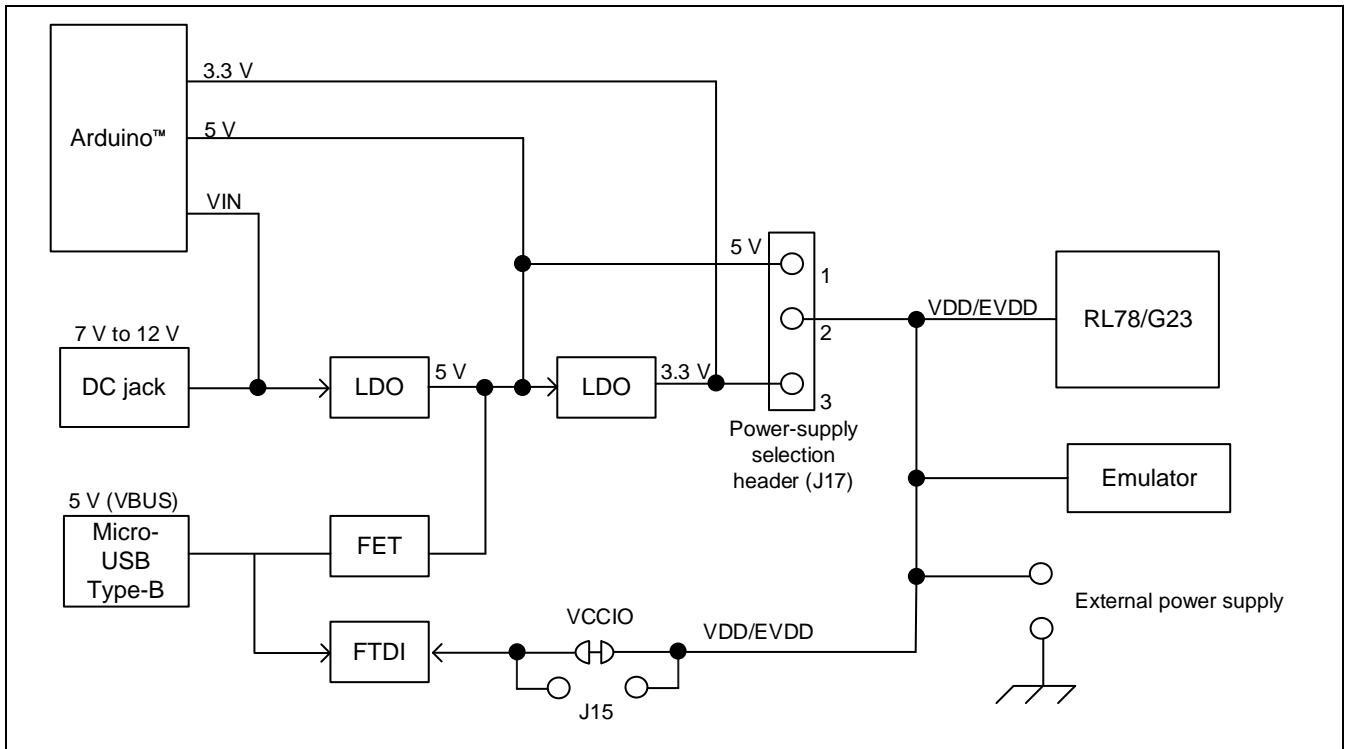

Figure 6-2 Block Diagram of the Power-Supply Circuit

7. Developing Code

Use the e² studio or CS+, both of which support the evaluation MCU (RL78/G23 with 64 pins).

7.1 Using the e² studio

Figure 7-1 shows the settings of the e² studio when it is to be connected to the RL78/G23-64p Fast Prototyping Board.

- [Debug hardware]: Select [COM port (RL78)].
- [Target Device]: Select [R7F100GLG].
- [Connection with Target Board]:
 [COM Port]: Select the COM port number for assignment to the RL78/G23-64p FPB from the pull-down list.
 [Reset control pin]: Select [DTR].

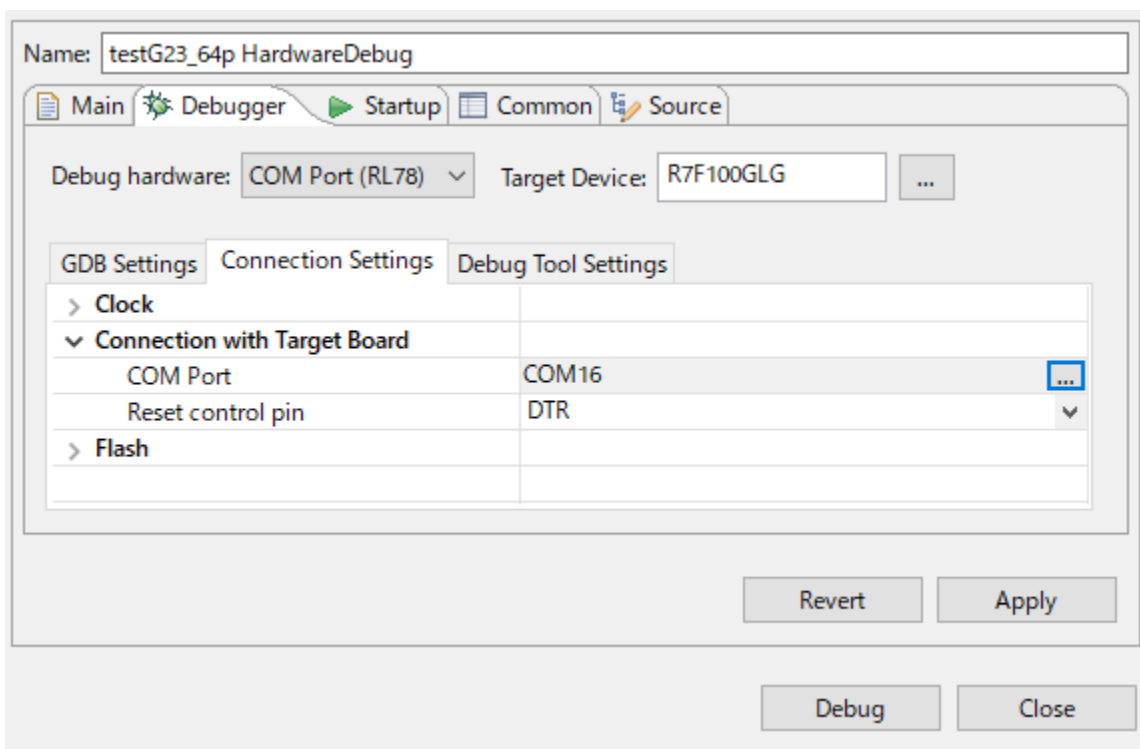

Figure 7-1 Settings of the e² studio

7.2 Using CS+

Figure 7-2 and Figure 7-3 show the settings of CS+ when it is to be connected to the RL78/G23-64p Fast Prototyping Board.

- [Using Debug Tool]:
Select [RL78 COM Port] from [Using Debug Tool] in the [Debug] menu.

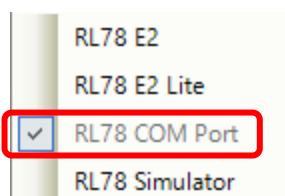

Figure 7-2 Panel for Selecting the Debug Tool

- [Connection with Target Board]:
[Communication port]: Select the COM port number for assignment to the RL78/G23-64p FPB from the pull-down list.
[Reset control pin]: Select [DTR].

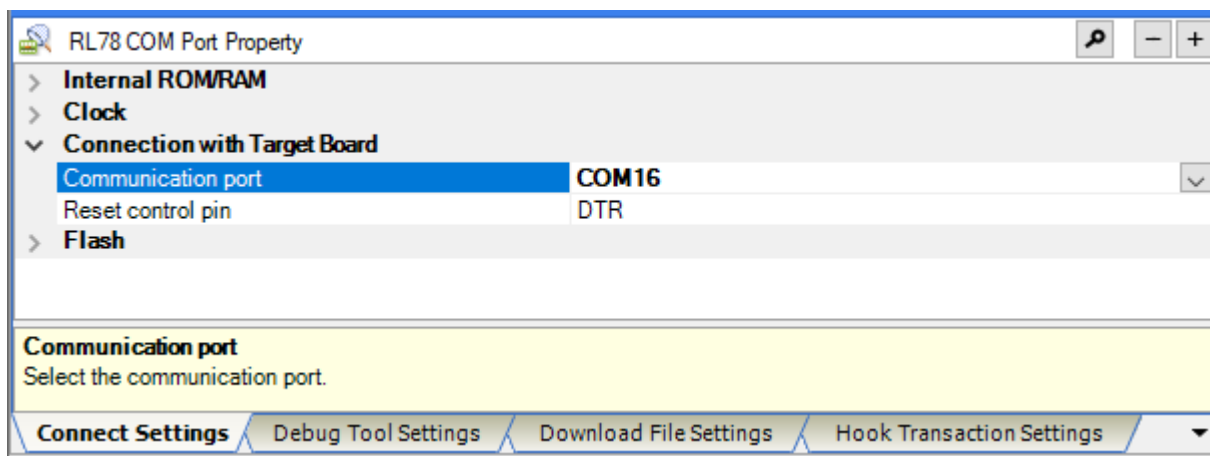

Figure 7-3 [Connect Settings] Tabbed Page of CS+

For details and points for caution, refer to the following application note for the RL78 COM port debug tool.

- RL78 Debugging Functions Using the Serial Port (R20AN0632)

8. Certifications

The RL78/G23-64p Fast Prototyping Board meets the following certifications/standards. See page 4 of this user's manual for the disclaimer and precautions.

8.1 EMC/EMI Standards

- CE Class A (EMC)



This product is herewith confirmed to comply with the requirements set out in the Council Directives on the Approximation of the laws of the Member States relating to Electromagnetic Compatibility Directive 2014/30/EU.

Warning – This is a Class A product. In a domestic environment this product may cause radio interference in which case the user may be required to take adequate measures to correct this interference.

1. UKCA Class A (EMC)



This product is in conformity with the following relevant UK Statutory Instrument(s) (and its amendments): 2016 No. 1091 Electromagnetic Compatibility Regulations 2016.

Warning – This is a Class A product. In a domestic environment this product may cause radio interference in which case the user may be required to take adequate measures to correct this interference.

- Taiwan: Chinese National Standard 13438, C6357 compliance, Class A limits
- Australia/New Zealand AS/NZS CISPR 32:2015, Class A

8.2 Material Selection, Waste, Recycling and Disposal Standards

- EU RoHS
- China SJ/T 113642014, 10-year environmental protection use period.
- WEEE Directive (2012/19/EU) & The Waste Electrical and Electronic Equipment Regulations 2013
The WEEE (Waste Electrical and Electronic Equipment) regulations put responsibilities on producers for the collection and recycling or disposal of electrical and electronic waste. Return of WEEE under these regulations is applicable in the UK and European Union.



This equipment (including all accessories) is not intended for household use. After use the equipment cannot be disposed of as household waste, and the WEEE must be treated, recycled and disposed of in an environmentally sound manner.

Renesas Electronics Europe GmbH can take back end of life equipment. Register for this service at; <https://www.renesas.com/eu/en/support/regional-customer-support/weee>

8.3 Safety Standards

- UL 94V-0

9.Design and Manufacturing Information

The design and manufacturing information for the RL78/G23-64p Fast Prototyping Board is available on https://www.renesas.com/rl78g23-64p_fpb.

Table 2. RL78/G23-64p Fast Prototyping Board design and manufacturing

File Type	Content	Title
File (PDF)	Schematics	RL78/G23-64p Fast Prototyping Board Schematics
File (PDF)	BoM	RL78/G23-64p Fast Prototyping Board BoM List
File (Zip)	PCB Design Files	RL78/G23-64p Fast Prototyping Board Desing and Gerber Files

10. Website and Support

Visit the following URLs to learn about the kit and the RL78 family of microcontrollers, download tools and documentation, and get support.

RL78/G23-64p Fast Prototyping Board Resources https://www.renesas.com/rl78g23-64p_fpb

RL78 Product Information [renesas.com/rl78](https://www.renesas.com/rl78)

RL78 Product Support Forum <https://community.renesas.com/mcu-mpu/rl78/>

RL78 Videos https://www.renesas.com/us/en/products/microcontrollers-microprocessors/rl78-low-power-8-16-bit-mcus#videos_training

Renesas Support [renesas.com/support](https://www.renesas.com/support)

Revision History	RL78/G23-64p Fast Prototyping Board User's Manual
------------------	---

Rev.	Date	Description	
		Page	Summary
1.00	Jan.16.21	—	First Edition issued
1.10	Jan.17.22	1	Descriptions were added to section 1.3, Preparation.
		21, 22	Figures for settings for use with the emulator connector and COM port debugging were added.
		23	Descriptions of "pattern for cutting" and "short-circuit pads" were added.
1.20	Jun.20.24	-	Add Disclaimer, Precautions, Proprietary Notic. Add "8.Cetifications", "9.Design and Manufacturing Information", "10.Website and Support".

RL78/G23-64p Fast Prototyping Board User's Manual

Publication Date: Rev.1.20 Jun.20.24

Published by: Renesas Electronics Corporation

RL78/G23



Renesas Electronics Corporation

R20UT4814EJ0120