

# RZ/T2M Group, RZ/N2L Group, RZ/T2L Group

R12UM0055EC0100  
Rev.1.00  
Jun.12, 2024

## CN032 AC Servo Solution Inverter Board Manual

### Abstract

This document describes the specifications of the CN032 Inverter Board using in CN032 AC Servo Solution by Renesas Electronics. We provide all the design files and BOM for customers to prepare their own hardware.

**<<Caution when handling the solution board>>**

**Be careful not to touch the board while power supply because CN032 AC servo solution board contains high voltage circuitry**

### Target Board

CN032 AC Servo Solution (for RZ/T2M, RZ/N2L, RZ/T2L)

### Related Document

- CN032 AC Servo Solution Inverter Board Manual (this manual)
- CN032 AC Servo Solution Hardware Manual (for RZ/T2M, RZ/N2L)
- CN032 AC Servo Solution Controller board Manual (for RZ/T2L)
- CN032 AC Servo Solution Firmware Manual
- CN032 AC Servo Solution Startup Guide (for Motion Utility Control)
- CN032 AC Servo Solution Startup Guide (for EtherCAT)
  
- RZ/T2M Group User's Manual: Hardware
- RZ/N2L Group User's Manual: Hardware
- RZ/T2L Group User's Manual: Hardware

**Contents**

1. Overview .....	3
2. Inverter Board Image .....	4
3. Schematic Description .....	5
3.1 AC-DC Power Supply .....	5
3.2 Capacitors Pre-charge Control .....	5
3.3 IPM Module .....	6
3.4 PWM x6 Signals .....	7
3.5 VFO Detection .....	7
3.6 P Voltage Sampling .....	8
3.7 Current Sampling .....	8
3.8 Brake Control .....	9
3.9 Brake Detection .....	9
3.10 Power Line Detection .....	9
3.11 Fan Control .....	10
3.12 NTC Detection .....	10
3.13 Controller Board Interface .....	11
3.14 Terminal Blocks .....	11
4. BOM List for Renesas Key Parts .....	12
Revision History .....	13

### 1. Overview

CN032 AC Servo Solution kit is a solution for Servo motor drive systems equipped with Renesas Electronics' RZ/T2M or RZ/N2L or RZ/T2L and related products. CN032 AC Servo Solution consists of two boards, a controller board equipped with RZ/T2M or RZ/N2L or RZ/T2L (hereinafter referred to as the controller board) and an inverter board.

This hardware manual describes the hardware information about inverter board.

The CN032 AC Servo Solution image is shown in Figure 1-1.

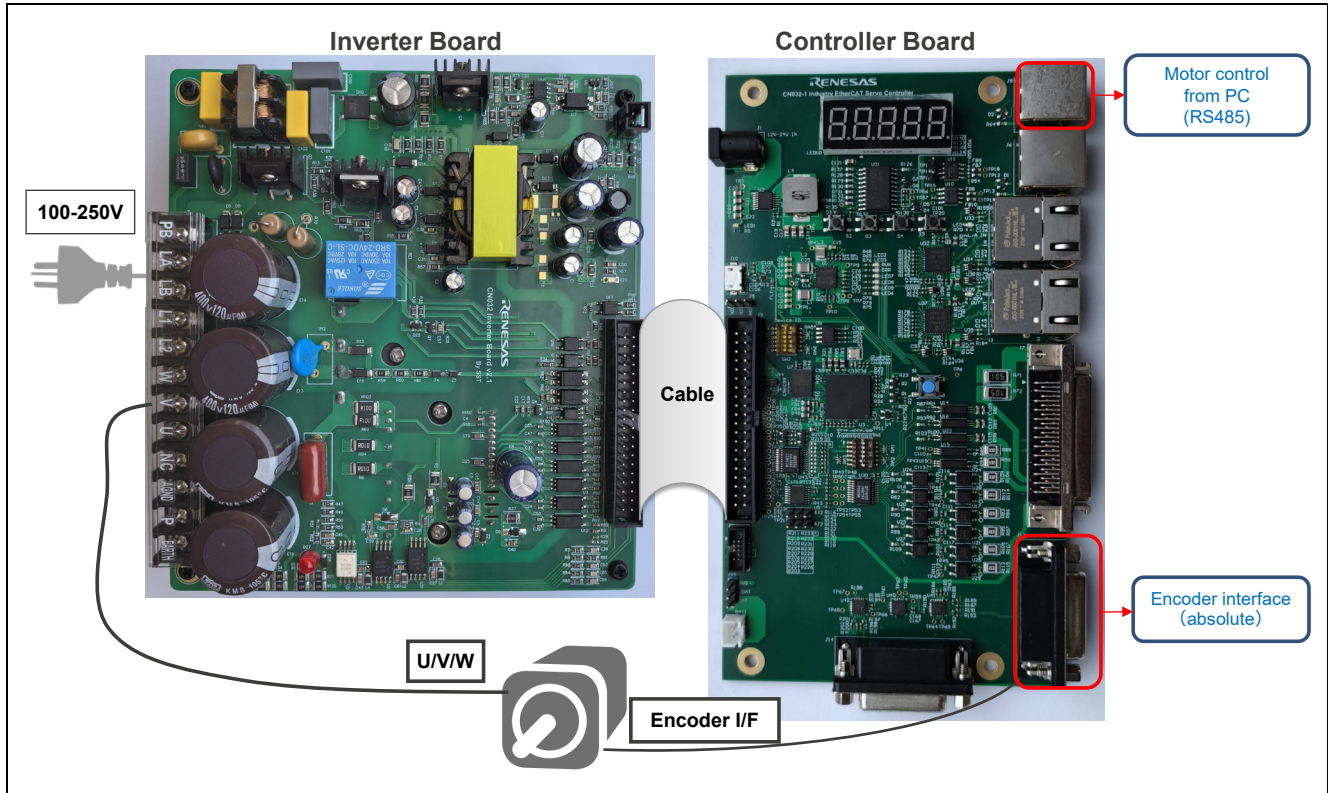

Figure 1-1 AC Servo Solution

The Table 1-1 Controller board and inverter board combination shows the combination of the controller board and inverter board. Operation is not guaranteed with any combination other than the following.

Table 1-1 Controller board and inverter board combination

No.	Controller board	Inverter board		
		V1.1	V1.2	V2.1
1	RZ/T2M(v1.1)	Available	Available	N/A
2	RZ/T2L(v1.0)	Available	Available	N/A
3	RZ/T2L(v2.0)	N/A	N/A	Available
4	RZ/N2L(v1.1)	Available	Available	N/A

## 2. Inverter Board Image

The Inverter Board image is shown in Figure 2-1 and Figure 2-2.

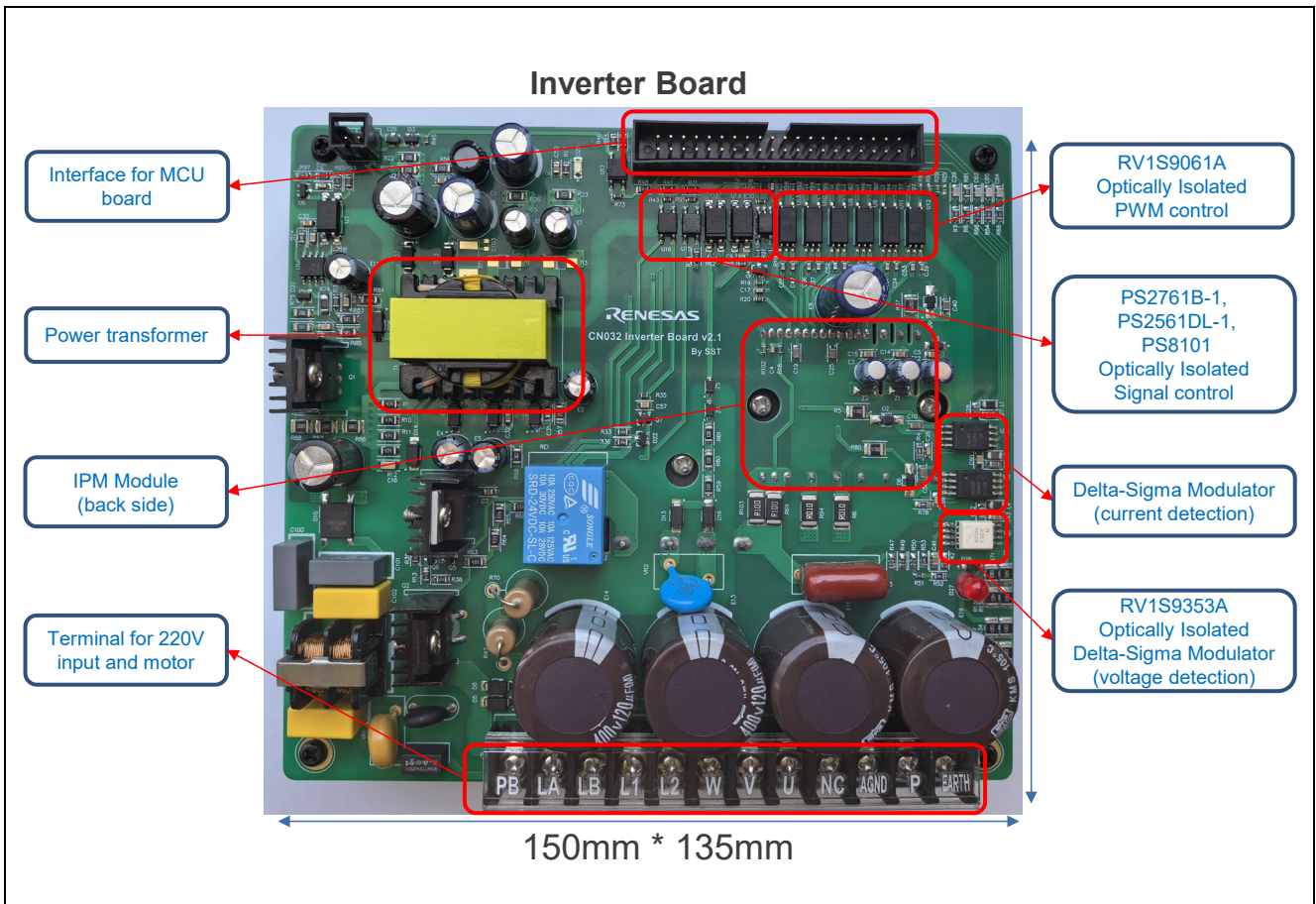

Figure 2-1 Inverter board (front)

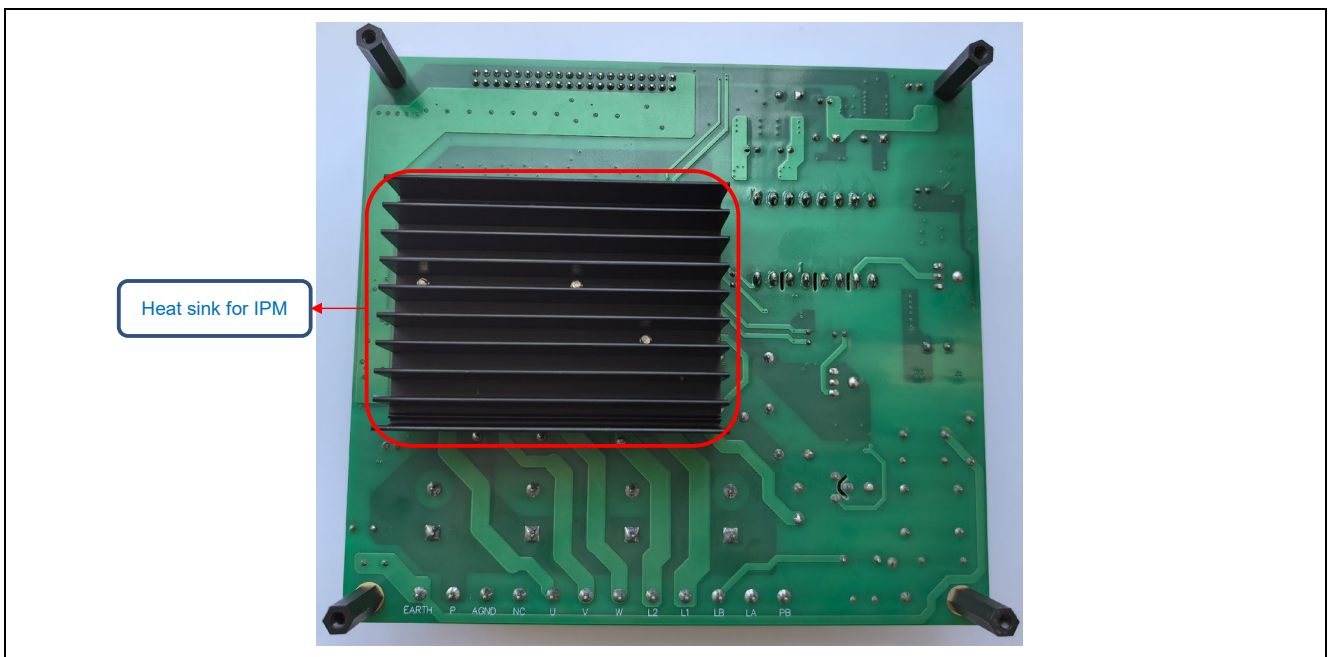

Figure 2-2 Inverter board (back)

### 3. Schematic Description

#### 3.1 AC-DC Power Supply

Inverter board can be inputted from 100V to 250V AC, and it provides the DC power supply for the related circuitry and the controller board.

1. The constant 15V VCC for IPM module and PWM input optocoupler, 5V power supply for delta-sigma modulator (current detection) at inverter board.
2. 5V/2A for main power supply and 24V/0.15A for external backup power to controller board. Please note that the 24V external backup power is not a constant one, because there is no feedback control. If customers want a constant 24V power supply for controller board, please add another external 24V power supply for application.

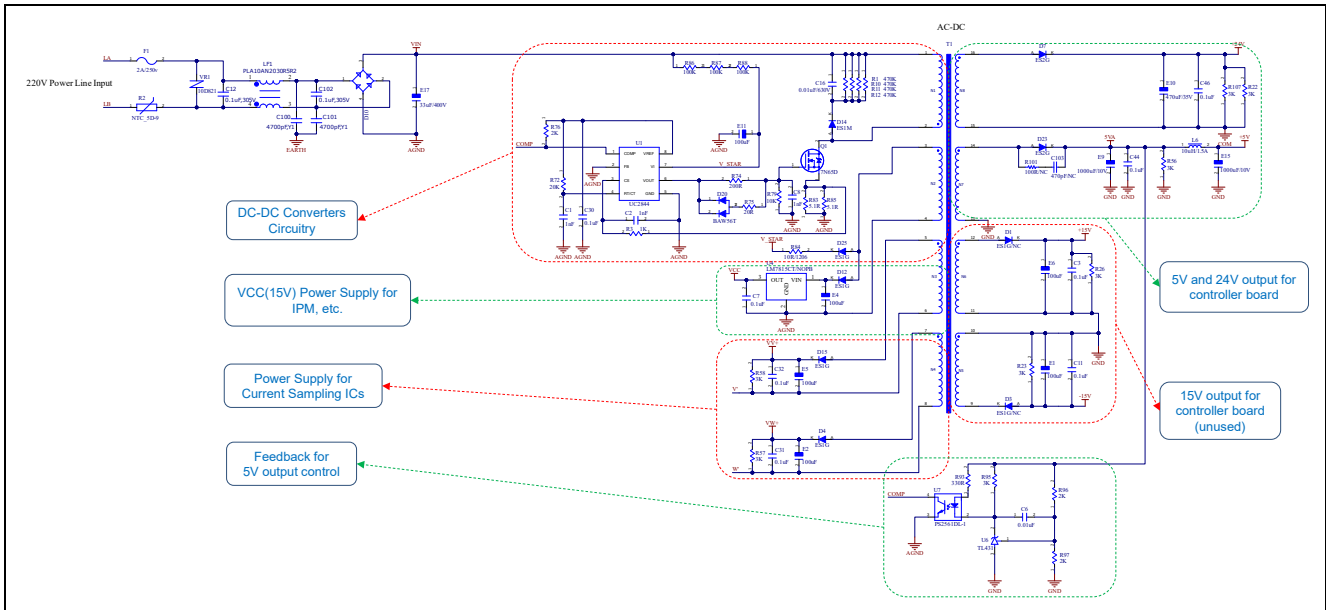

Figure 3-1 AC-DC Power Supply

#### 3.2 Capacitors Pre-charge Control

The P voltage is power supply to IPM module for AC motor control, comes from the AC input voltage passing through the rectifier bridge and filtering capacitors. Since these filtering capacitors are parallel installed with 120uF value, the pre-charge circuitry is need for these capacitors. Resistors R42 and R70 are used for pre-charge to limit the charging current, after that, a control signal (RY) from controller board will turn on the relay for motor control.

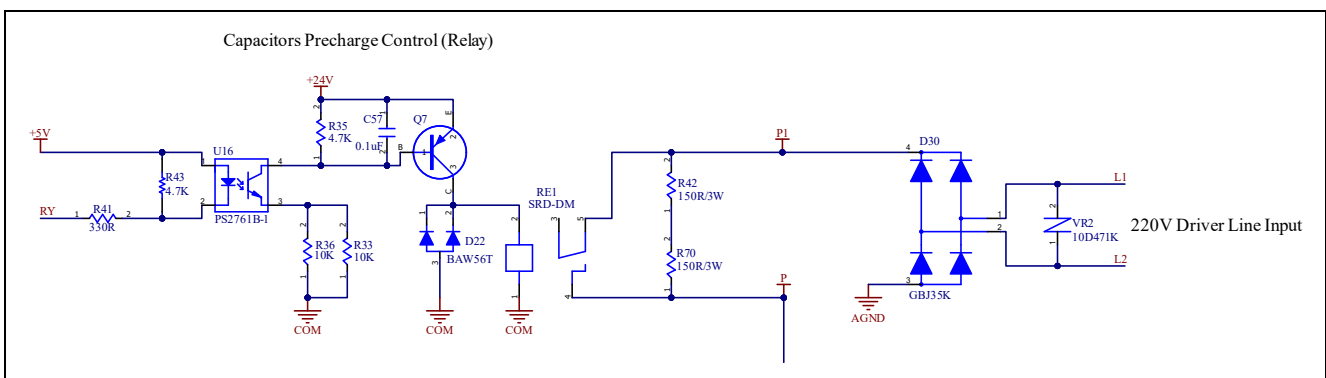

Figure 3-2 Capacitors Pre-charge Control

### 3.3 IPM Module

The IPM module PSS15S93E6-AG is used for the application on AC 100~240Vrms (DC voltage: 400V or below) class low power motor control, support 15A max current.

For more information, please refer to the related manual.

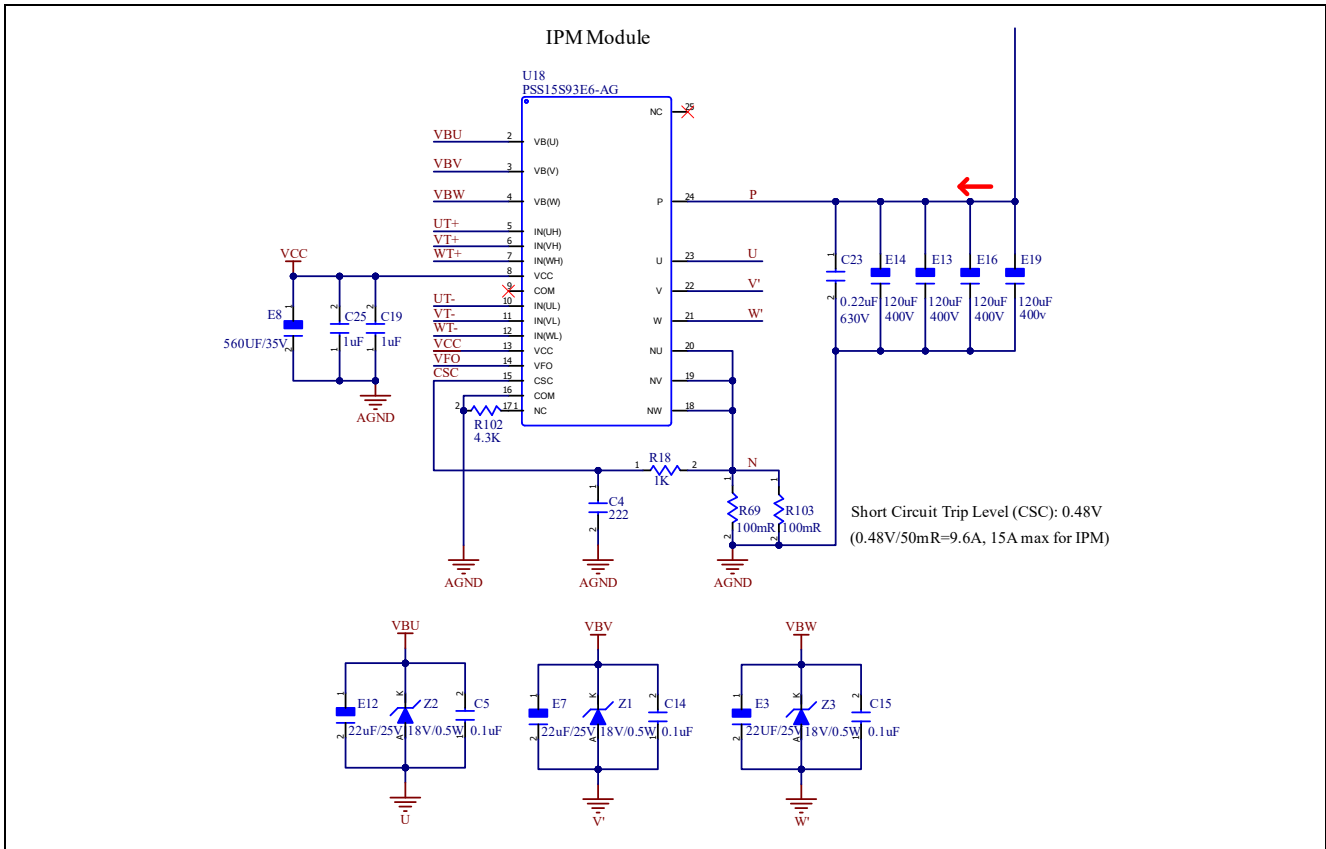

Figure 3-3 IPM Module



### 3.4 PWM x6 Signals

6 channel PWM control signals output from controller board, and input to IPM module for AC motor control through high-speed photocoupler RV1S9061A.

The RV1S9061A is a photocoupler featuring high-speed switching up to 15 Mbps with active high output logic which consists of an AlGaAs LED on the input side and an integrated circuitry with a photodiode on the output.

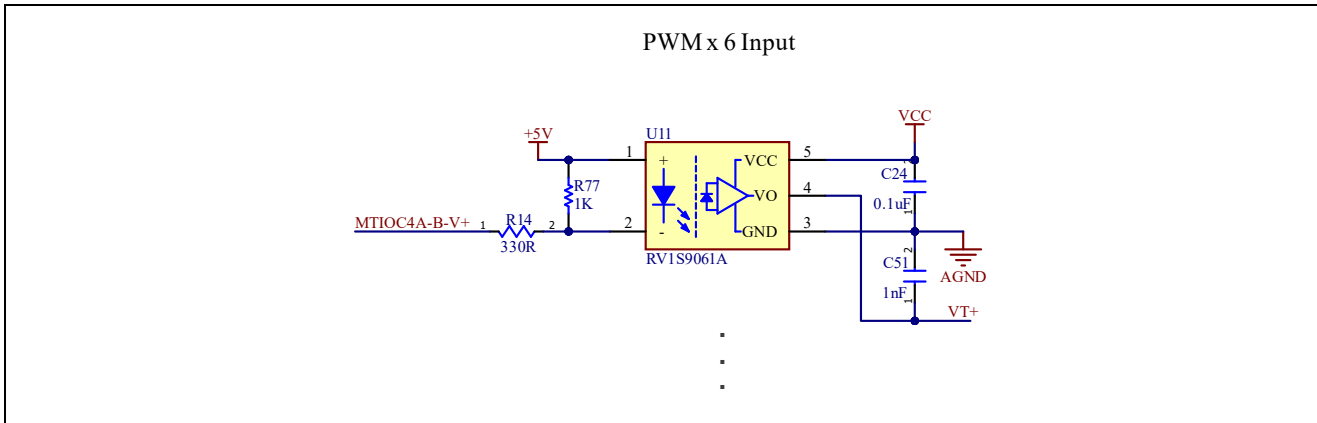

Figure 3-4 PWM x6 Signals

### 3.5 VFO Detection

Fault signal Fo outputs (VFO) when SC, UV or OT protection works in IPM module. Fo pulse width is different for each protection modes. At SC failure, Fo pulse width is a fixed width (=minimum 20us), But at UV or OT failure, Fo outputs continuously until recovering from UV or OT state.

The SC protection current can be selected from external shunt resistance. At current design, 50mR shunt resistance is used, and the protection current is about 9.6A, refer to Figure 3-3.

Short Circuit Trip Level (CSC):  $0.48V, 0.48V/50mR=9.6A$  (15A max for IPM).

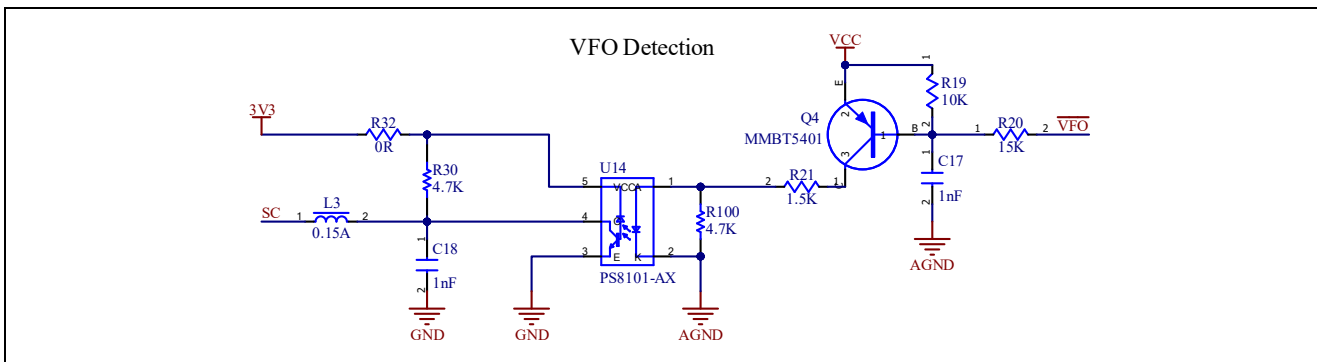

Figure 3-5 VFO Detection

### 3.6 P Voltage Sampling

Figure 3-6 shows the P voltage sampling circuitry, using Renesas optically isolated delta-sigma modulator RV1S9353A, the DS Modulator signal outputs to the delta-sigma interface of the controller board MPU directly.

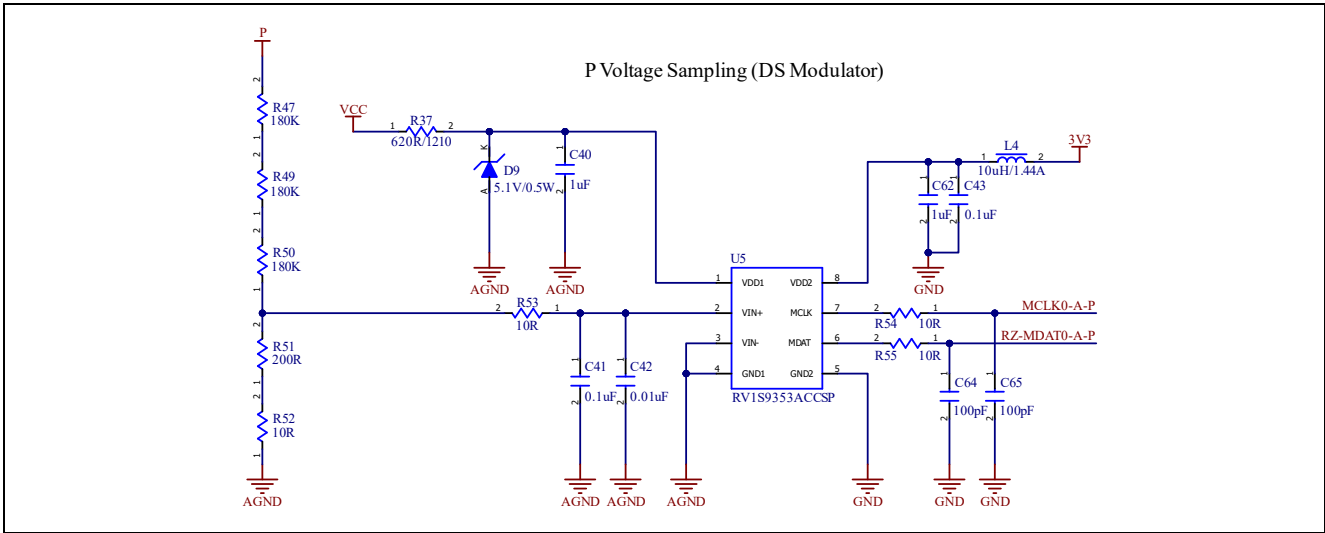

Figure 3-6 P Voltage Sampling

### 3.7 Current Sampling

Figure 3-7 shows the V/W phase current sampling circuitry, the DS Modulator signal outputs to the delta-sigma interface of the controller board MPU directly.

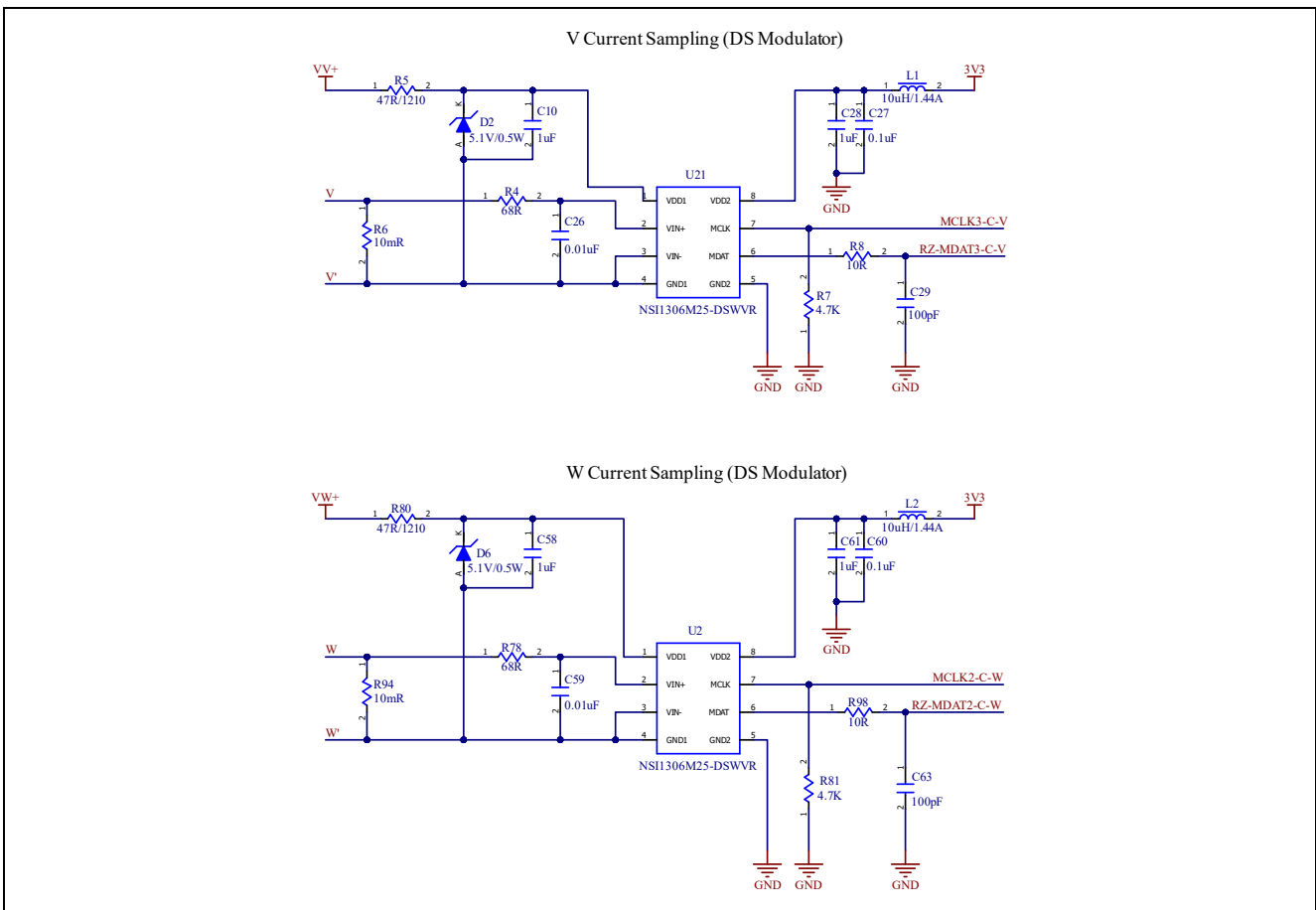

Figure 3-7 Current Sampling



### 3.8 Brake Control

Figure 3-8 shows the brake control circuitry, which controlled by an GPIO of MPU from the controller board through photocoupler PS2761B-1.

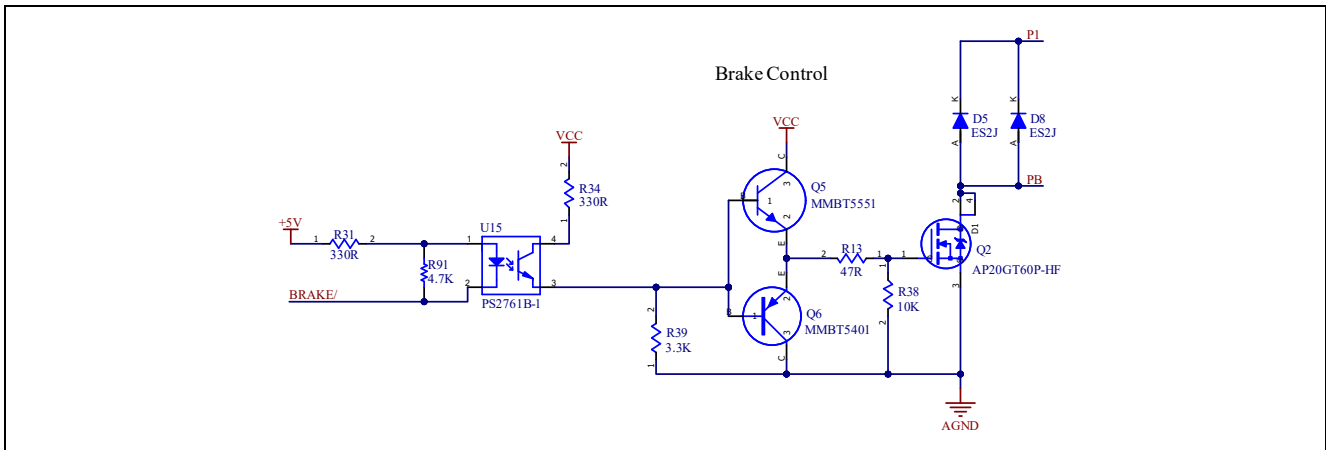

Figure 3-8 Brake Control

### 3.9 Brake Detection

Figure 3-9 shows the brake control circuitry, the voltage PB is detected by an GPIO of MPU from the controller board through photocoupler PS2561DL-1.

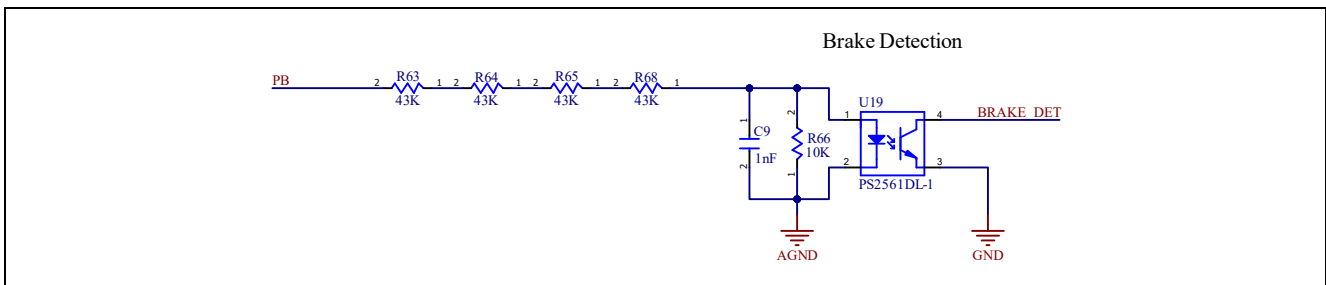

Figure 3-9 Brake Detection

### 3.10 Power Line Detection

Figure 3-10 shows the power line (L1, L2) detection circuitry, the power line voltage is detected by an GPIO of MPU from the controller board through photocoupler PS2561DL-1.

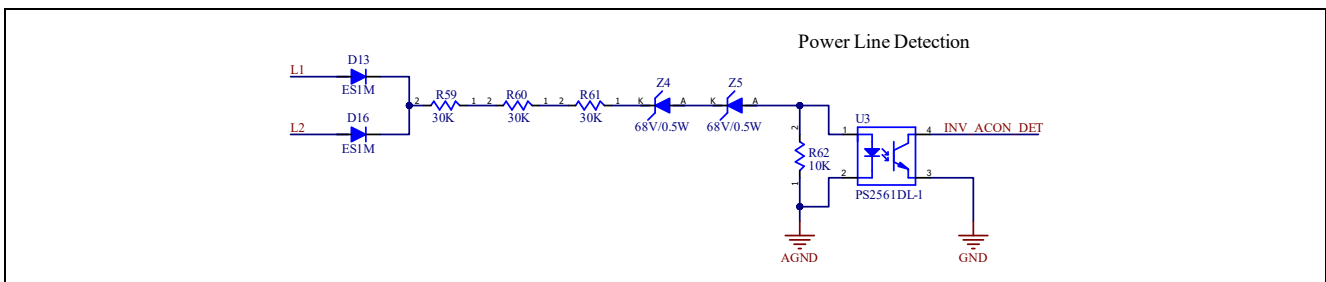

Figure 3-10 Power Line Detection

### 3.11 Fan Control

Figure 3-11 shows the fan control circuitry, which controlled by an GPIO of MPU from the controller board through photocoupler PS2761B-1. This is a reserved function to cool the heat sink.

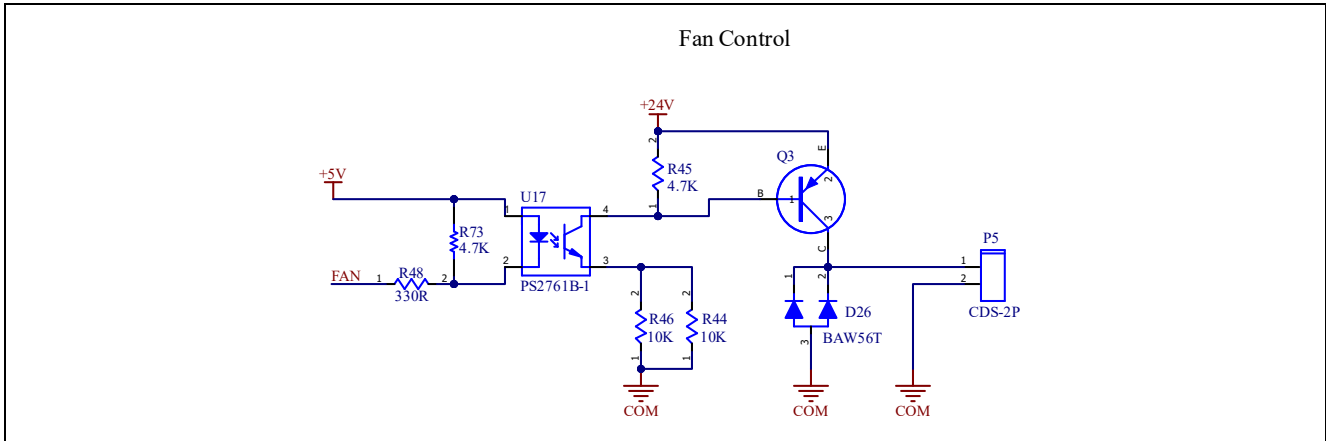

Figure 3-11 Fan Control

### 3.12 NTC Detection

Figure 3-12 shows the NTC detection circuitry, the user can place a NTC component R25 for their application, which is detected by an ADC channel of MPU from the controller board. This is a reserved function.

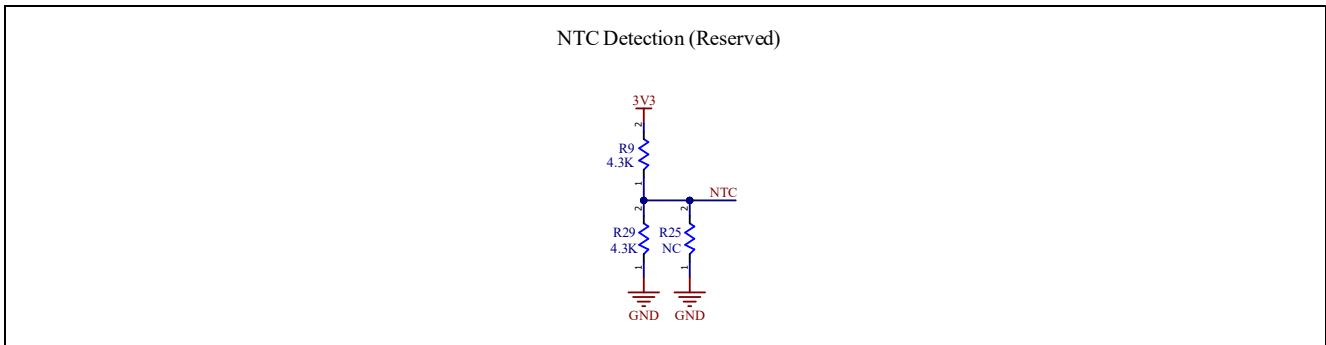

Figure 3-12 NTC Detection

### 3.13 Controller Board Interface

The inverter board provides 5V to the controller board through below interface as main power supply, also it makes motor control by U/V/W signals, 3 channels DS Modulator signal, and input/output signals.

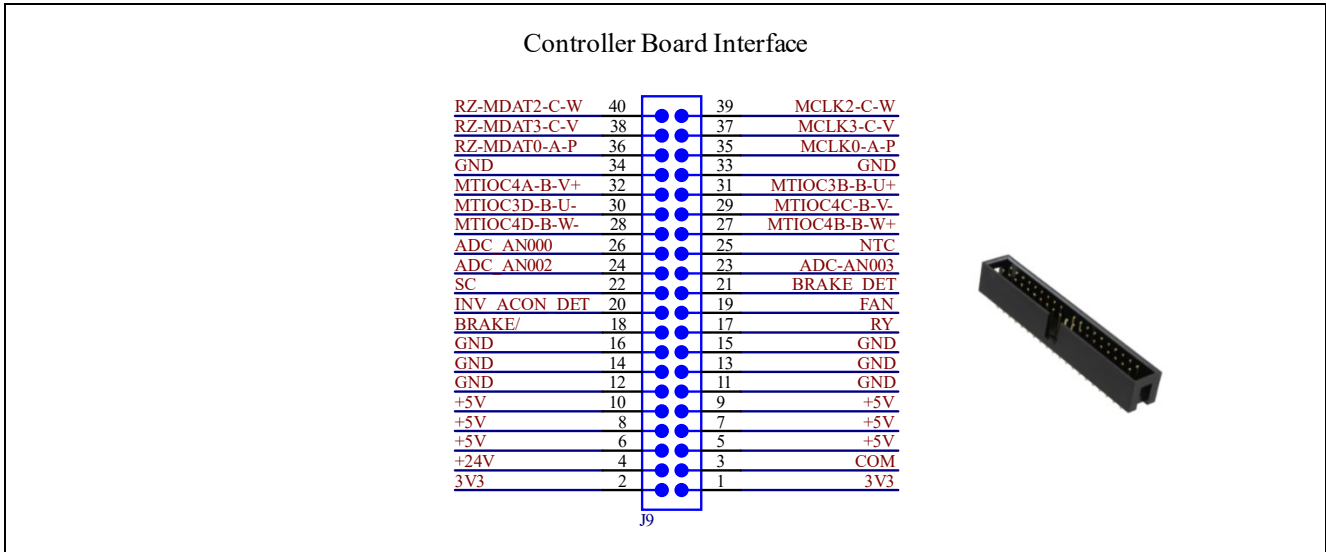

Figure 3-13 Controller Board Interface

### 3.14 Terminal Blocks

The inverter board need to be inputted 100-250V AC for motor power and controller power. L1/L2 is input to IPM for motor power, and LA/LB is input to transformer for controller power, they are dividual.

P/AGND also can input DC power for motor power, if don't input AC power from L1/L2.

PB is for brake control.

EARTH is for ground of 100-250V power and motor FG.

Pin2-8 are the necessary input for achieving the servo motor control.

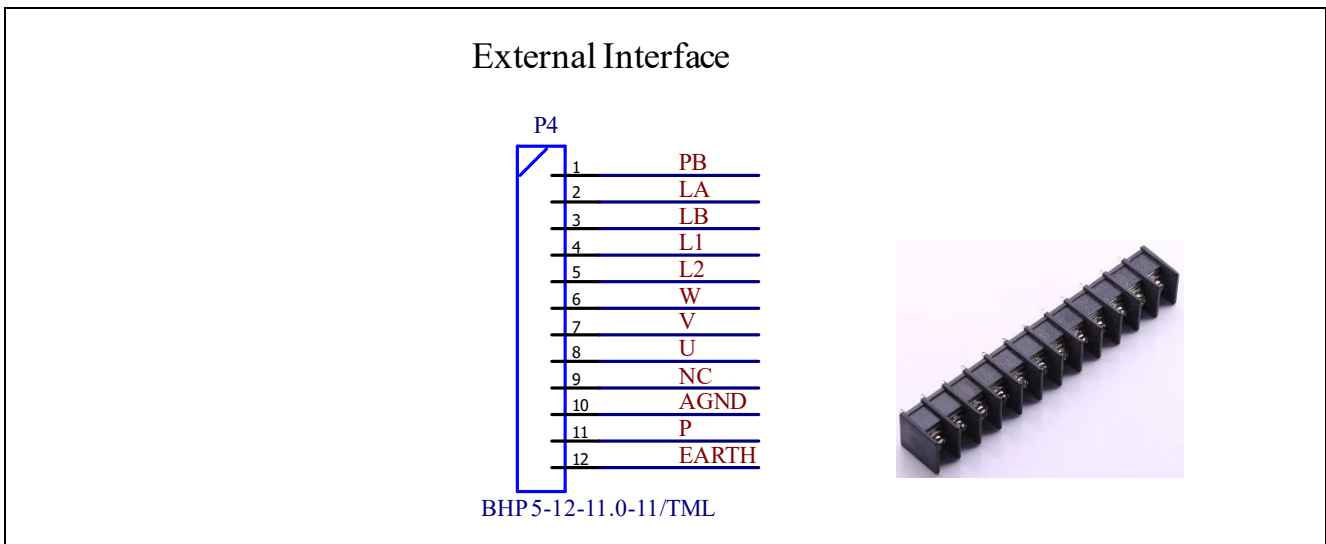

Figure 3-14 Terminal Blocks

#### 4. BOM List for Renesas Key Parts

Renesas provides the complete design files for this AC Servo Solution application, includes SCH, PCB, BOM, etc.

Here are the Renesas Key parts used in inverter board, for more information, please refer to the related files from Renesas.

##### BOM List from Inverter Board

Designator	Description	Manufacturer	Mfg Part Number	Quantity
U3, U7, U19	OPTOISOLATOR 5KV TRANS 4SMD	Renesas	PS2561DL-1	3
U5	DELTA-SIGMA MODULATOR (OPTOCPLR)	Renesas	RV1S9353A	1
U8, U9, U10, U11, U12, U13	15Mbps IPM Drive Photocouplers	Renesas	RV1S9061A	6
U14	OPTOISO 3.75KV PUSH PULL 6SO	Renesas	PS8101-AX	1
U15, U16, U17	OPTOISOLATOR 3.75KV TRANS 4SOP	Renesas	PS2761B-1	3

**Revision History**

Rev.	Date	Description	
		Page	Summary
1.00	Jun.12, 2024	-	First Edition issued

## General Precautions in the Handling of Microprocessing Unit and Microcontroller Unit Products

The following usage notes are applicable to all Microprocessing unit and Microcontroller unit products from Renesas. For detailed usage notes on the products covered by this document, refer to the relevant sections of the document as well as any technical updates that have been issued for the products.

### 1. Precaution against Electrostatic Discharge (ESD)

A strong electrical field, when exposed to a CMOS device, can cause destruction of the gate oxide and ultimately degrade the device operation. Steps must be taken to stop the generation of static electricity as much as possible, and quickly dissipate it when it occurs. Environmental control must be adequate. When it is dry, a humidifier should be used. This is recommended to avoid using insulators that can easily build up static electricity.

Semiconductor devices must be stored and transported in an anti-static container, static shielding bag or conductive material. All test and measurement tools including work benches and floors must be grounded. The operator must also be grounded using a wrist strap. Semiconductor devices must not be touched with bare hands. Similar precautions must be taken for printed circuit boards with mounted semiconductor devices.

### 2. Processing at power-on

The state of the product is undefined at the time when power is supplied. The states of internal circuits in the LSI are indeterminate and the states of register settings and pins are undefined at the time when power is supplied. In a finished product where the reset signal is applied to the external reset pin, the states of pins are not guaranteed from the time when power is supplied until the reset process is completed. In a similar way, the states of pins in a product that is reset by an on-chip power-on reset function are not guaranteed from the time when power is supplied until the power reaches the level at which resetting is specified.

### 3. Input of signal during power-off state

Do not input signals or an I/O pull-up power supply while the device is powered off. The current injection that results from input of such a signal or I/O pull-up power supply may cause malfunction and the abnormal current that passes in the device at this time may cause degradation of internal elements. Follow the guideline for input signal during power-off state as described in your product documentation.

### 4. Handling of unused pins

Handle unused pins in accordance with the directions given under handling of unused pins in the manual. The input pins of CMOS products are generally in the high-impedance state. In operation with an unused pin in the open-circuit state, extra electromagnetic noise is induced in the vicinity of the LSI, an associated shoot-through current flows internally, and malfunctions occur due to the false recognition of the pin state as an input signal become possible.

### 5. Clock signals

After applying a reset, only release the reset line after the operating clock signal becomes stable. When switching the clock signal during program execution, wait until the target clock signal is stabilized. When the clock signal is generated with an external resonator or from an external oscillator during a reset, ensure that the reset line is only released after full stabilization of the clock signal. Additionally, when switching to a clock signal produced with an external resonator or by an external oscillator while program execution is in progress, wait until the target clock signal is stable.

### 6. Voltage application waveform at input pin

Waveform distortion due to input noise or a reflected wave may cause malfunction. If the input of the CMOS device stays in the area between  $V_{IL}$  (Max.) and  $V_{IH}$  (Min.) due to noise, for example, the device may malfunction. Take care to prevent chattering noise from entering the device when the input level is fixed, and also in the transition period when the input level passes through the area between  $V_{IL}$  (Max.) and  $V_{IH}$  (Min.).

### 7. Prohibition of access to reserved addresses

Access to reserved addresses is prohibited. The reserved addresses are provided for possible future expansion of functions. Do not access these addresses as the correct operation of the LSI is not guaranteed.

### 8. Differences between products

Before changing from one product to another, for example to a product with a different part number, confirm that the change will not lead to problems. The characteristics of a microprocessing unit or microcontroller unit products in the same group but having a different part number might differ in terms of internal memory capacity, layout pattern, and other factors, which can affect the ranges of electrical characteristics, such as characteristic values, operating margins, immunity to noise, and amount of radiated noise. When changing to a product with a different part number, implement a system-evaluation test for the given product.

- Arm and Cortex are registered trademarks of Arm Limited (or its subsidiaries) in the EU and other countries. All rights reserved.
- Ethernet is a registered trademark of Fujitsu Xerox Co., Ltd.
- IEEE is a registered trademark of the Institute of Electrical and Electronics Engineers Inc
- EtherCAT® is registered trademark and patented technology, licensed by Beckhoff Automation GmbH, Germany.
- Additionally all product names and service names in this document are a trademark or a registered trademark which belongs to the respective owners.

## Notice

1. Descriptions of circuits, software and other related information in this document are provided only to illustrate the operation of semiconductor products and application examples. You are fully responsible for the incorporation or any other use of the circuits, software, and information in the design of your product or system. Renesas Electronics disclaims any and all liability for any losses and damages incurred by you or third parties arising from the use of these circuits, software, or information.
2. Renesas Electronics hereby expressly disclaims any warranties against and liability for infringement or any other claims involving patents, copyrights, or other intellectual property rights of third parties, by or arising from the use of Renesas Electronics products or technical information described in this document, including but not limited to, the product data, drawings, charts, programs, algorithms, and application examples.
3. No license, express, implied or otherwise, is granted hereby under any patents, copyrights or other intellectual property rights of Renesas Electronics or others.
4. You shall be responsible for determining what licenses are required from any third parties, and obtaining such licenses for the lawful import, export, manufacture, sales, utilization, distribution or other disposal of any products incorporating Renesas Electronics products, if required.
5. You shall not alter, modify, copy, or reverse engineer any Renesas Electronics product, whether in whole or in part. Renesas Electronics disclaims any and all liability for any losses or damages incurred by you or third parties arising from such alteration, modification, copying or reverse engineering.
6. Renesas Electronics products are classified according to the following two quality grades: "Standard" and "High Quality". The intended applications for each Renesas Electronics product depends on the product's quality grade, as indicated below.
  - "Standard": Computers; office equipment; communications equipment; test and measurement equipment; audio and visual equipment; home electronic appliances; machine tools; personal electronic equipment; industrial robots; etc.
  - "High Quality": Transportation equipment (automobiles, trains, ships, etc.); traffic control (traffic lights); large-scale communication equipment; key financial terminal systems; safety control equipment; etc.
- Unless expressly designated as a high reliability product or a product for harsh environments in a Renesas Electronics data sheet or other Renesas Electronics document, Renesas Electronics products are not intended or authorized for use in products or systems that may pose a direct threat to human life or bodily injury (artificial life support devices or systems; surgical implantations; etc.), or may cause serious property damage (space system; undersea repeaters; nuclear power control systems; aircraft control systems; key plant systems; military equipment; etc.). Renesas Electronics disclaims any and all liability for any damages or losses incurred by you or any third parties arising from the use of any Renesas Electronics product that is inconsistent with any Renesas Electronics data sheet, user's manual or other Renesas Electronics document.
7. No semiconductor product is absolutely secure. Notwithstanding any security measures or features that may be implemented in Renesas Electronics hardware or software products, Renesas Electronics shall have absolutely no liability arising out of any vulnerability or security breach, including but not limited to any unauthorized access to or use of a Renesas Electronics product or a system that uses a Renesas Electronics product. RENESAS ELECTRONICS DOES NOT WARRANT OR GUARANTEE THAT RENESAS ELECTRONICS PRODUCTS, OR ANY SYSTEMS CREATED USING RENESAS ELECTRONICS PRODUCTS WILL BE INVULNERABLE OR FREE FROM CORRUPTION, ATTACK, VIRUSES, INTERFERENCE, HACKING, DATA LOSS OR THEFT, OR OTHER SECURITY INTRUSION ("Vulnerability Issues"). RENESAS ELECTRONICS DISCLAIMS ANY AND ALL RESPONSIBILITY OR LIABILITY ARISING FROM OR RELATED TO ANY VULNERABILITY ISSUES. FURTHERMORE, TO THE EXTENT PERMITTED BY APPLICABLE LAW, RENESAS ELECTRONICS DISCLAIMS ANY AND ALL WARRANTIES, EXPRESS OR IMPLIED, WITH RESPECT TO THIS DOCUMENT AND ANY RELATED OR ACCOMPANYING SOFTWARE OR HARDWARE, INCLUDING BUT NOT LIMITED TO THE IMPLIED WARRANTIES OF MERCHANTABILITY, OR FITNESS FOR A PARTICULAR PURPOSE.
8. When using Renesas Electronics products, refer to the latest product information (data sheets, user's manuals, application notes, "General Notes for Handling and Using Semiconductor Devices" in the reliability handbook, etc.), and ensure that usage conditions are within the ranges specified by Renesas Electronics with respect to maximum ratings, operating power supply voltage range, heat dissipation characteristics, installation, etc. Renesas Electronics disclaims any and all liability for any malfunctions, failure or accident arising out of the use of Renesas Electronics products outside of such specified ranges.
9. Although Renesas Electronics endeavors to improve the quality and reliability of Renesas Electronics products, semiconductor products have specific characteristics, such as the occurrence of failure at a certain rate and malfunctions under certain use conditions. Unless designated as a high reliability product or a product for harsh environments in a Renesas Electronics data sheet or other Renesas Electronics document, Renesas Electronics products are not subject to radiation resistance design. You are responsible for implementing safety measures to guard against the possibility of bodily injury, injury or damage caused by fire, and/or danger to the public in the event of a failure or malfunction of Renesas Electronics products, such as safety design for hardware and software, including but not limited to redundancy, fire control and malfunction prevention, appropriate treatment for aging degradation or any other appropriate measures. Because the evaluation of microcomputer software alone is very difficult and impractical, you are responsible for evaluating the safety of the final products or systems manufactured by you.
10. Please contact a Renesas Electronics sales office for details as to environmental matters such as the environmental compatibility of each Renesas Electronics product. You are responsible for carefully and sufficiently investigating applicable laws and regulations that regulate the inclusion or use of controlled substances, including without limitation, the EU RoHS Directive, and using Renesas Electronics products in compliance with all these applicable laws and regulations. Renesas Electronics disclaims any and all liability for damages or losses occurring as a result of your noncompliance with applicable laws and regulations.
11. Renesas Electronics products and technologies shall not be used for or incorporated into any products or systems whose manufacture, use, or sale is prohibited under any applicable domestic or foreign laws or regulations. You shall comply with any applicable export control laws and regulations promulgated and administered by the governments of any countries asserting jurisdiction over the parties or transactions.
12. It is the responsibility of the buyer or distributor of Renesas Electronics products, or any other party who distributes, disposes of, or otherwise sells or transfers the product to a third party, to notify such third party in advance of the contents and conditions set forth in this document.
13. This document shall not be reprinted, reproduced or duplicated in any form, in whole or in part, without prior written consent of Renesas Electronics.
14. Please contact a Renesas Electronics sales office if you have any questions regarding the information contained in this document or Renesas Electronics products.

(Note1) "Renesas Electronics" as used in this document means Renesas Electronics Corporation and also includes its directly or indirectly controlled subsidiaries.

(Note2) "Renesas Electronics product(s)" means any product developed or manufactured by or for Renesas Electronics.

(Rev.5.0-1 October 2020)

## Corporate Headquarters

TOYOSU FORESIA, 3-2-24 Toyosu,  
Koto-ku, Tokyo 135-0061, Japan  
[www.renesas.com](http://www.renesas.com)

## Trademarks

Renesas and the Renesas logo are trademarks of Renesas Electronics Corporation. All trademarks and registered trademarks are the property of their respective owners.

## Contact information

For further information on a product, technology, the most up-to-date version of a document, or your nearest sales office, please visit:  
[www.renesas.com/contact/](http://www.renesas.com/contact/).