

User Manual

DA1459x Pro-Development Kit

UM-B-167

Abstract

This is the description of the DA1459x Development Kit Pro hardware which provides a tested reference platform, access to all signals for connecting peripherals and advanced debugging features.

Contents

Abstract	1
Contents	2
Figures	3
Tables	3
1 Terms and Definitions	5
2 References	5
3 Introduction	6
3.1 Features of DA1459x Pro-DB.....	6
3.2 Features of DA1459x Pro-MB	7
3.3 Pro Devkit hardware block diagram.....	7
4 Getting to Know DA1459x Pro Devkit	8
4.1 The Hardware components of the DA1459x Pro Devkit.....	8
4.1.1 Set up hardware of DA1459x Devkit with PMM2.....	8
4.1.2 Set up hardware of DA1459x Devkit without PMM2.....	9
4.1.3 Jumper settings	10
4.2 DA14592 Pro-DB.....	11
4.2.2 XTAL, 32 MHz (Y1).....	16
4.2.3 XTAL, 32 kHz (Y2).....	16
4.2.4 Debugging connector (J4).....	16
4.2.5 QSPI external memory (U2).....	17
4.2.6 General purpose LED (D1).....	18
4.2.7 The RESET on DA14592 Pro-Daughterboard.....	19
4.2.8 Power section of DA14592 Pro-Daughterboard.....	19
4.2.9 RF section.....	21
4.3 DA1459x Pro-MB.....	22
4.3.1 DA1459x signals distribution on Pro-Motherboard.....	23
4.3.2 USB port (USB1) and USB HUB (U11).....	25
4.3.3 USB to UART (U12)	25
4.3.4 USB to SWD (U5).....	26
4.3.5 Debugging signals, DIP switch, and Level translation	27
4.3.6 Reset.....	28
4.3.7 Push button (K1).....	29
4.3.8 MikroBUS and PMOD interface.....	29
4.3.9 Power section	31
4.3.10 Measurements and software triggers	32
4.4 The Power measurement module 2 (PMM2), (500-29-x)	36
4.4.1 Accuracy of Current Measurement for VBAT System (VLDO)	39
5 Schematics	41
A.1 DA1459x Pro-Motherboard schematic.....	41
A.2 DA1459x_db_fcqfn52 schematic	46
A.3 DA1459x-db-wlcsp39 schematic.....	48
Revision History	50

DA1459x Pro-Development Kit
Figures

Figure 1. DA1459x Pro Devkit with Pro-MB and the Pro-DB.....	6
Figure 2. System block diagram.....	7
Figure 3. DA1459x Pro Devkit components	8
Figure 4. Default hardware setup of DA1459x Pro-Devkit with PMM2.....	9
Figure 5. System block diagram of DA14592 Pro-DB (32 kHz only on FCQFN52)	12
Figure 6. TOP side, WLCSP39 Pro-DB (left), FCQFN52 Pro-DB (right).....	12
Figure 7. BOTTOM side, WLCSP39 Pro-DB (left), FCQFN52 Pro-DB (right).....	13
Figure 8. DA1459x Interface header of WLCSP39 to DA1459x Pro-Motherboard	14
Figure 9. DA1459x Interface header of FCQFN52 to DA1459x Pro-Motherboard.....	15
Figure 10. The debugging header, J4.....	17
Figure 11. The External QSPI memory, (U2) place holder.....	18
Figure 12. External Memory placeholder and the components.....	18
Figure 13. Red LED (D1) circuitry	19
Figure 14. Reset circuitry on Pro-Daughterboard.....	19
Figure 15. DA14592 SoC, power pins.....	20
Figure 16. SW1 (left), available battery sockets on the bottom side of the daughterboards (right)....	21
Figure 17. RF section of DA14592 Pro-DB	21
Figure 18. DA1459x Pro-Motherboard block diagram	22
Figure 19. DA1459x Pro-Motherboard, 469-16-x	23
Figure 20. USB HUB circuitry of DA14531 Pro-MB	25
Figure 21. USB to UART (U12).....	26
Figure 22. USB to SWD (U4).....	27
Figure 23. Voltage level translation circuit	28
Figure 24. RESET circuit on DA1459x Pro-MB.....	29
Figure 25. General purpose Push button K1	29
Figure 26. MikroBus and PMOD	30
Figure 27. DA1459x Pro MB Power section block diagram block.....	31
Figure 28. DA14592x Pro-Motherboard Power section	32
Figure 29. Power measurement module (PMM2) block diagram	33
Figure 30. Current measurement socket (M2).....	34
Figure 31. Selection jumper block (J24) and Buffer MOSFETS for I/O levels compatibility.....	35
Figure 32. DA1459x waveforms, captured from Power profiler of SmartSnippet Toolbox	36
Figure 33. PMM2 current measurement circuit PMM2.....	37
Figure 34. PMM2 on board peripherals (power supply, memory and so on)	38
Figure 35. Current measurement unit PCBA (TOP).....	39
Figure 36. Normal mode (1 μ A to 640 mA at 3.3 V) data after offset calibration.....	40
Figure 37. Hibernation mode (100 nA to 60 μ A at 3.3 V) data after offset calibration	40
Figure 38. DA1459x Pro-Motherboard schematic, modification history page.....	41
Figure 39. DA1459x Pro-Motherboard schematic, connectivity, and level translators.....	42
Figure 40. DA1459x Pro-Motherboard schematic, SWD implementation	43
Figure 41. DA1459x Pro-Motherboard schematic, PMM2 interface and software trigger buffers.....	44
Figure 42. DA1459x Pro-Motherboard schematic, USB Hub, UART to USB and power supply	45
Figure 43. DA1459x_db_fcqfn52, modification history page	46
Figure 44. DA1459x_db_fcqfn52, the circuit.....	47
Figure 45. DA1459x-db-wlcs39, modification history page.....	48
Figure 46. DA1459x-db-wlcs39, the circuit.....	49

Tables

Table 1. Headers and Jumper settings of DA1459x Pro-Devkit.....	10
Table 2. DA14592 ordering information.....	11
Table 3. DA1459x WLCSP39 pins assignment.....	14
Table 4. DA1459x FCQFN52 pins assignment	15
Table 5. Crystal specification.....	16

DA1459x Pro-Development Kit

Table 6. Debugging header –pins assignment.....	17
Table 7. DA1459x signal connectivity on Pro-Motherboard.....	24
Table 8. Signal mapping on DIP switch (S1).....	27
Table 9. MikroBUS and PMOD signals	31
Table 10. Monitored power sources.....	34
Table 11. Accuracy of the current measurement circuit.....	40

DA1459x Pro-Development Kit**1 Terms and Definitions**

DK	Development Kit
LPF	Low Pass Filter
PCB	Printed Circuit Board
Pro Devkit	Professional Development Kit
Pro-MB	Professional Motherboard
Pro-DB	Professional Daughterboard
SDK	Software Development Kit
SoC	System on Chip
SWD	Serial Wire Debug

2 References

[1] DA1459x, Datasheet, Renesas Electronics.

Note 1 References are for the latest published version, unless otherwise indicated.

DA1459x Pro-Development Kit

3 Introduction

This document describes the hardware of DA1459x Pro development kit (DK). The DA1459x Pro DK is available as a motherboard, two variants of a daughterboard (FCQFN52/WLCSP39) and the power measurement module PMM2, [Figure 1](#).

The Pro development kit when combined with the DA1459x SDK and Smart Snippets tools, provides an easy to use and complete platform for software/hardware development.

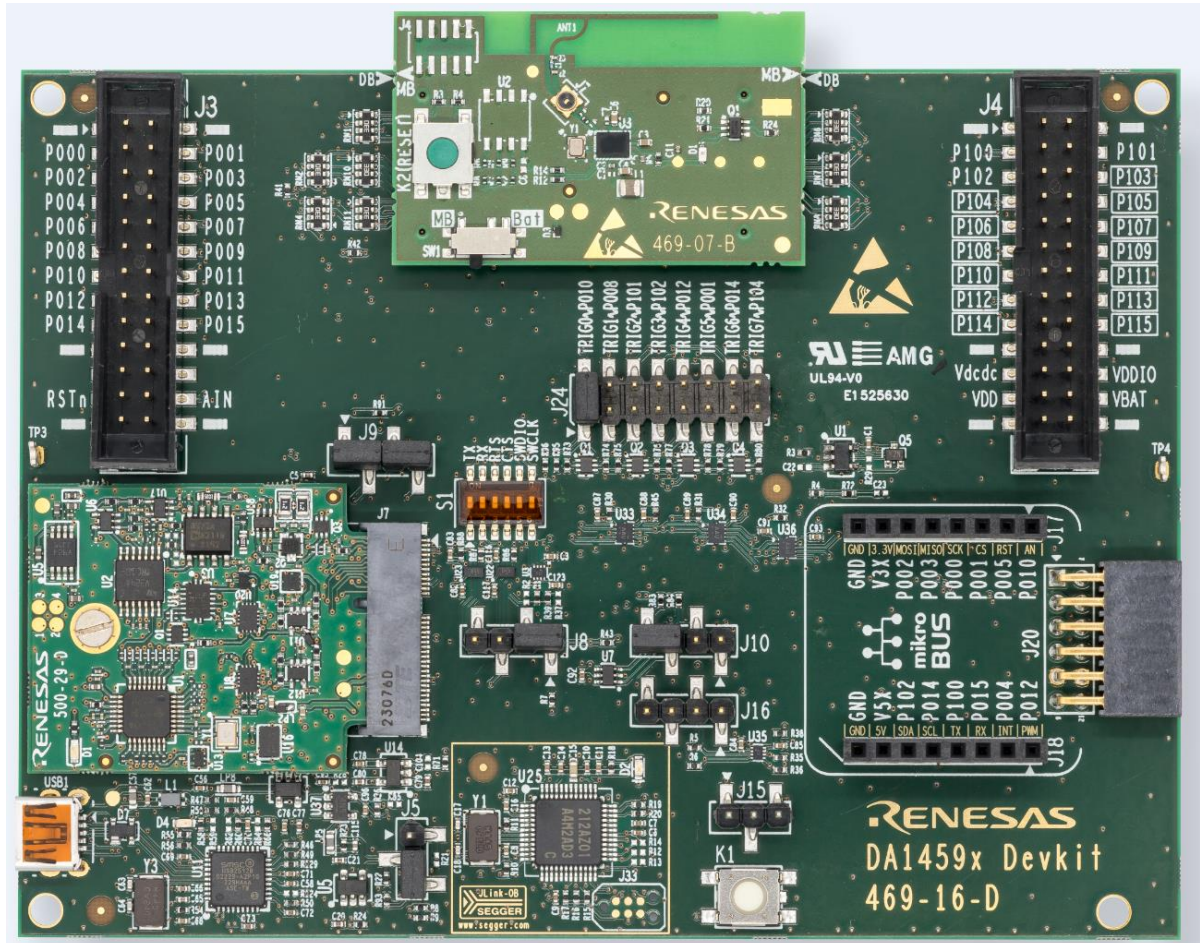

Figure 1. DA1459x Pro Devkit with Pro-MB and the Pro-DB

3.1 Features of DA1459x Pro-DB

- Embedded printed antenna
- Coaxial switch for conducted RF measurements
- Option for QSPI-Flash memory or PSRAM
- Reset button
- LED
- Flexible battery options
- Crystals 32 MHz, 32.768 kHz (optional – only for FCQFN52 package)
- Support for coin cell battery.

DA1459x Pro-Development Kit

3.2 Features of DA1459x Pro-MB

- Mating connectors for connecting a DA1459x Pro-DB which hosts either DA1459x FCQFN52 or WLCSP39 SoC
- Headers for I/O monitoring and expandability
- Option to support MikroBUS click boards.
- Provisions for automated test
- On-board basic peripherals for demo and development
- JTAG(SWD) debugger and connectivity to PC.

3.3 Pro Devkit hardware block diagram

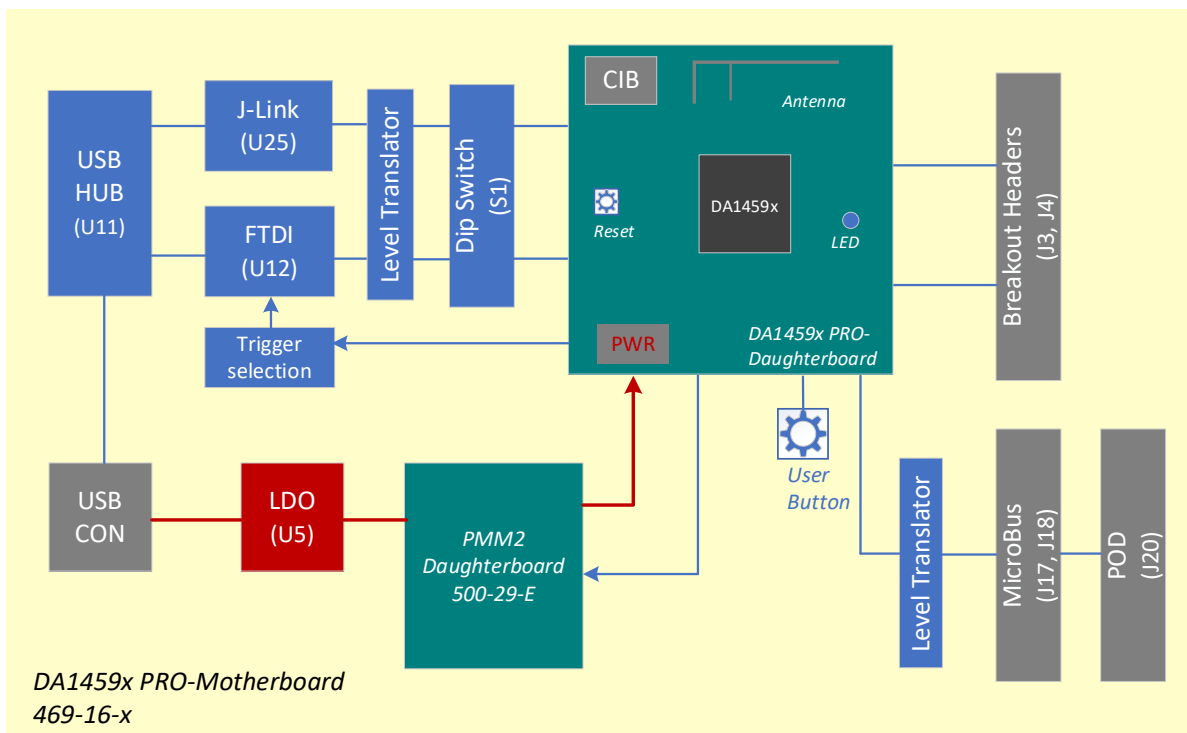

Figure 2. System block diagram

4 Getting to Know DA1459x Pro Devkit

4.1 The Hardware components of the DA1459x Pro Devkit

In this document we focus on the DA1459x DK Pro which consists of the following parts:

- Pro-Motherboard, DA1459x Pro-MB: PCBA reference number 469-16-D
- Pro-Daughterboard (two options, interchangeable)
 - FCQFN52 Pro-DB: it uses DA1459x -FCQFN52. PCBA reference number 469-08-B
 - WLCSP39 Pro-DB: it uses DA1459x-WLCSP39. PCBA reference number 469-07-B
- Power measurement module, PMM2. PCBA reference number 500-29-E.

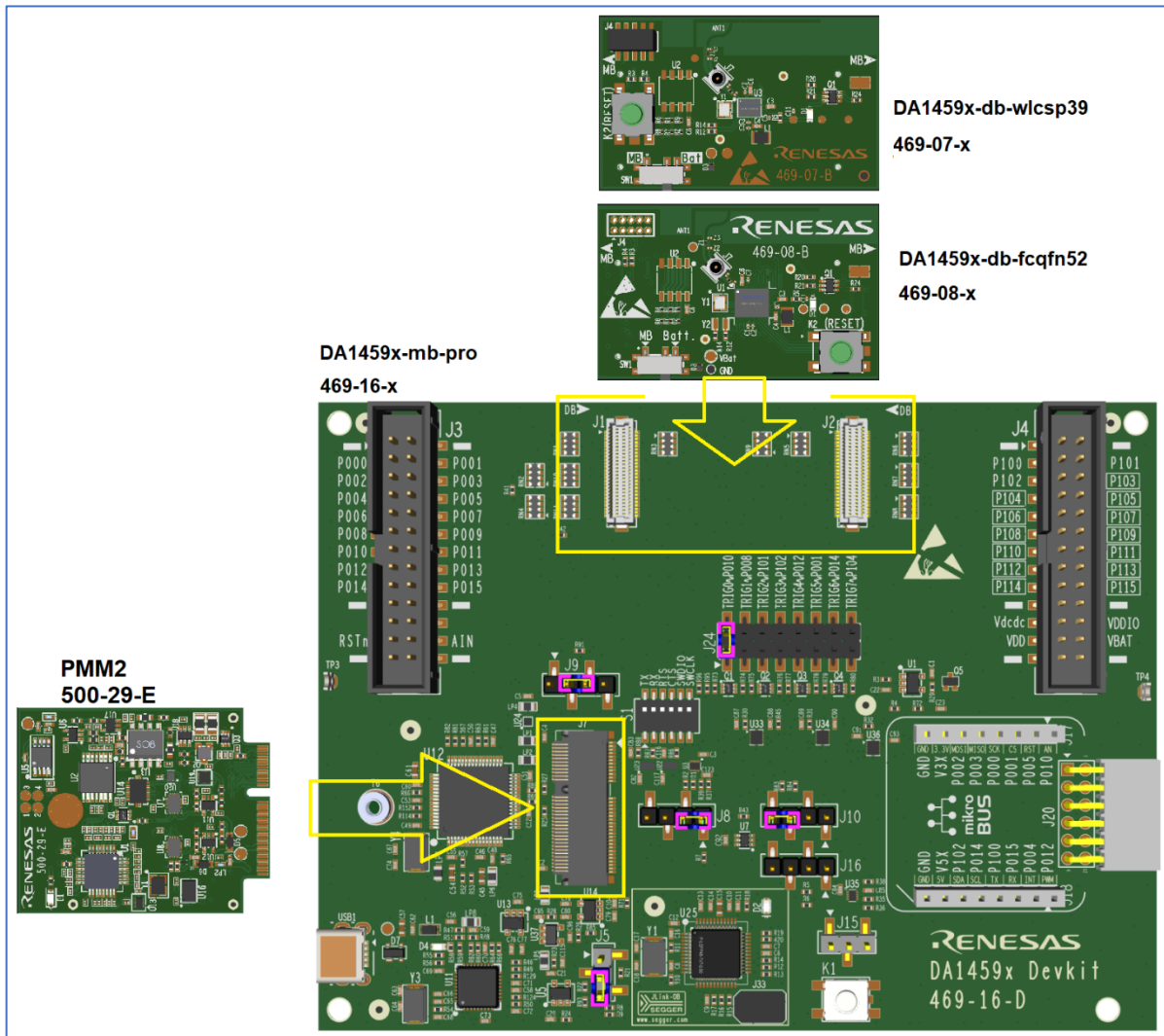

Figure 3. DA1459x Pro Devkit components

4.1.1 Set up hardware of DA1459x Devkit with PMM2

1. Mount Pro-Daughterboard (469-08-x or 469-07-x). Ensure the proper orientation, by checking the alignment marks of the two PCBAs.
2. Mount PMM2 as shown in Figure 4. The mounting screw (M2x4, D5x0.5 or similar) must be also applied.
3. Mount two jumpers on J9, between pins 1 and 2 and 3 and 4.

DA1459x Pro-Development Kit

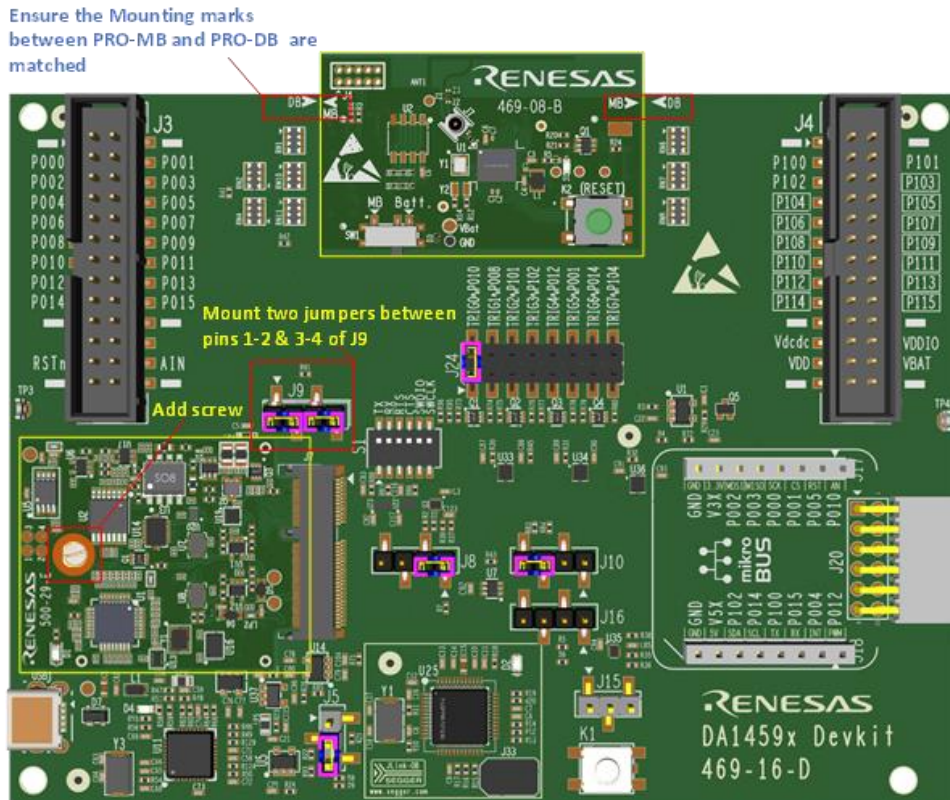

Figure 4. Default hardware setup of DA1459x Pro-Devkit with PMM2

4.1.2 Set up hardware of DA1459x Devkit without PMM2

1. Mount Pro-Daughterboard (469-08-x or 469-07-x). Ensure the proper orientation by checking the alignment marks of the two PCBAs.
2. Mount one jumper on J9, between pins 2 and 3.

DA1459x Pro-Development Kit

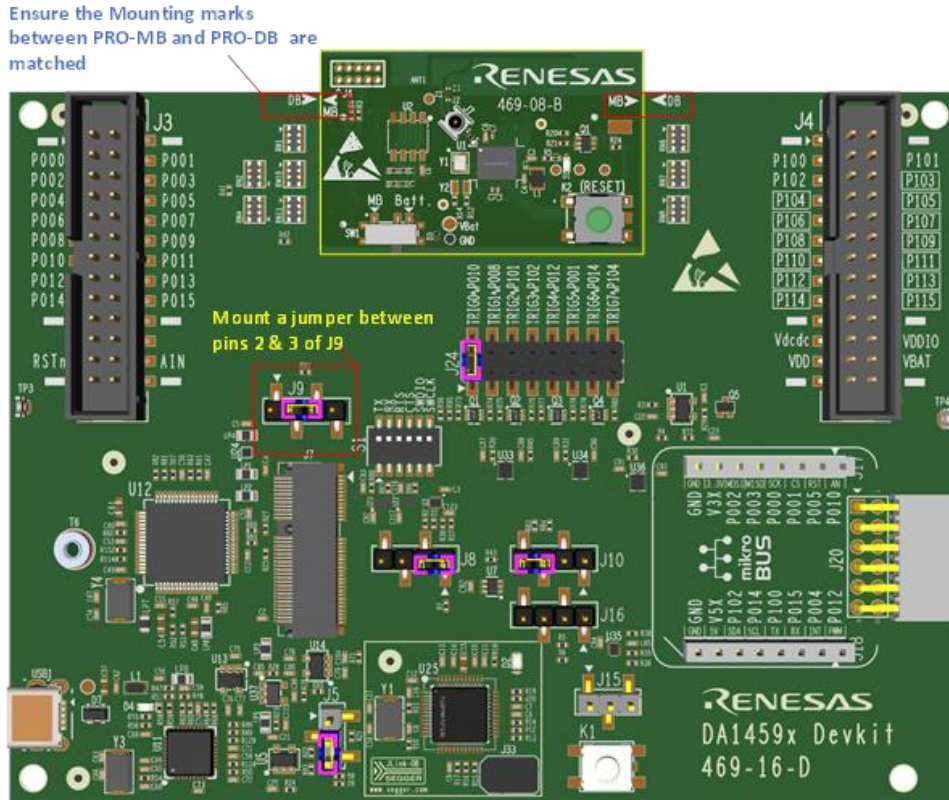

Figure 5. Hardware setup of DA1459x Pro-Devkit without PMM2

4.1.3 Jumper settings

Table 1. Headers and Jumper settings of DA1459x Pro-Devkit

HDR	Function of headers	Jumper Options		Default Jumper setting
J5	DA1459x input voltage, generated from LDO (U5)	1.8 V	Mount pos. 1-2 Or No mount 1-2	Mounted 2-3
		3.0 V	Mount pos. 2-3	
J8	K1, general purpose push button and (pins 1-2) Force enable Power_Enable (3-4), for supplying Pro-Devkit with a power source without USB data connection	Enable K1	Mount pos. 1-2	Mounted 1-2
		Force Power_Enable	Mount pos. 3-4	No mounted 3-4
J9	Power Measurement Module PMM2	PMM2 Bypass	Mount pos. 2-3	<i>PMM2 mounted:</i> Mounted 1-2
		PMM2 Enable	Mount pos.1-2 Mount pos. 3-4	Mounted 3-4 <i>PMM2 no mounted:</i> Mounted 2-3
J10	Reset source options	Activate Reset driven from Debugger (T_Reset)	Mount pos.1-2	Mounted 1-2

DA1459x Pro-Development Kit

HDR	Function of headers	Jumper Options		Default Jumper setting
		Activate Reset driven from serial interface (U_RSTn)	Mount pos. 3-4	No mounted 3-4
J15	Enable Pullups of I2C for PMOD and MikroBUS	Disable I2C	No jumper Mount	
		Power Pull-ups with 3.3 V	Mount pos.1-2	No mounted 1-2
		Power Pull-ups with 5 V	Mount pos.2-3	No mounted 3-4
J16	Enable I2C signals for PMOD and MikroBUS	Enable SDA	Mount pos.1-2	No mounted 1-2
		Enable SCL	Mount pos.3-4	No mounted 3-4
J24	Software Trigger activation	TRIG_0 mapped to P0_10 TRIG_1 mapped to P0_08 TRIG_2 mapped to P1_01 TRIG_3 mapped to P1_02 TRIG_4 mapped to P0_12 TRIG_5 mapped to P0_01 TRIG_6 mapped to P0_14 TRIG_7 mapped to P1_04	Mount pos.1-2 Mount pos.3-4 Mount pos.5-6 Mount pos.7-8 Mount pos. 9-10 Mount pos.11-12 Mount pos.13-14 Mount pos.15-16	Mounted 1-2

For enabling I2C for MikroBUS or PMOD, both J15 and J16 must be set.

4.2 DA14592 Pro-DB

On Pro-daughterboard, system consists of DA14592 SoC, crystals 32 MHz and 32 kHz (for FCQFN52 package only), Switch SW1 for power source selection, radio section (printed antenna and RF connector), LED and RESET button (Figure 5). There are two versions of the DA14592 SoC, WLCSP39 and FCQFN52 with the ordering information in Table 2.

Table 2. DA14592 ordering information

Part Number	Package	Size (mm)
DA14592-01000O92	WLCSP39	3.32 x 2.48 x 0.37
DA14592-010006F2	FCQFN52	5.1 x 4.3 x 0.78

There two variants of Pro-daughterboard are (Figure 6):

- for the FCQFN52 package (469-08-x), and
- for the WLCSP39 package (469-07-x).

The difference between the two daughterboards, apart from layout differences, is that the FCQFN52 daughterboard exposes more GPIOs to the motherboard and provides a place holder for a 32 kHz crystal. Both variants provide a place holder for external Flash.

On the power section, both variants provide a place holder for a coin cell battery. DA1459x SoC can be supplied from the battery through switch SW1.

DA1459x Pro-Development Kit

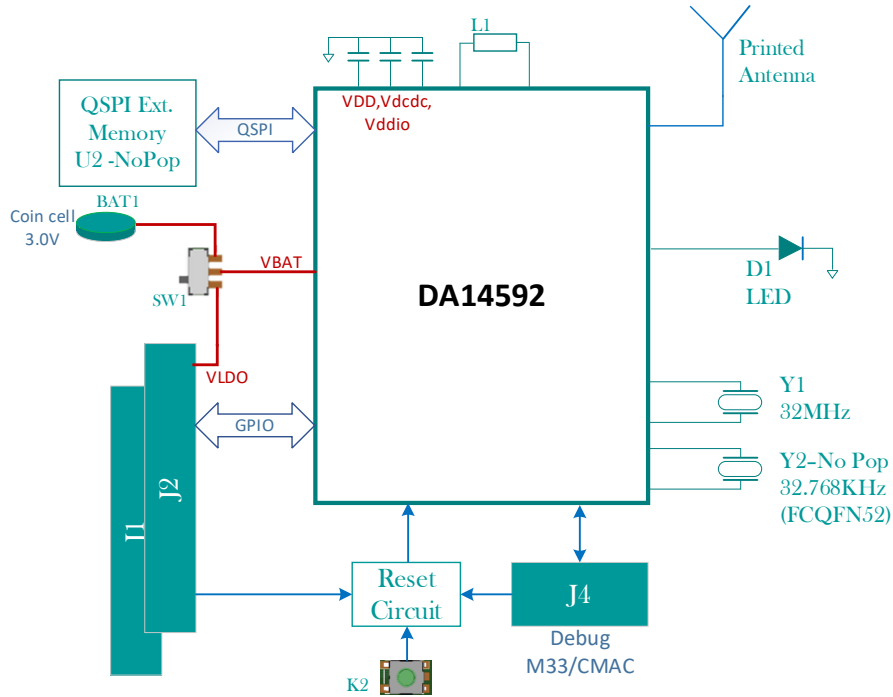

Figure 5. System block diagram of DA14592 Pro-DB (32 kHz only on FCQFN52)

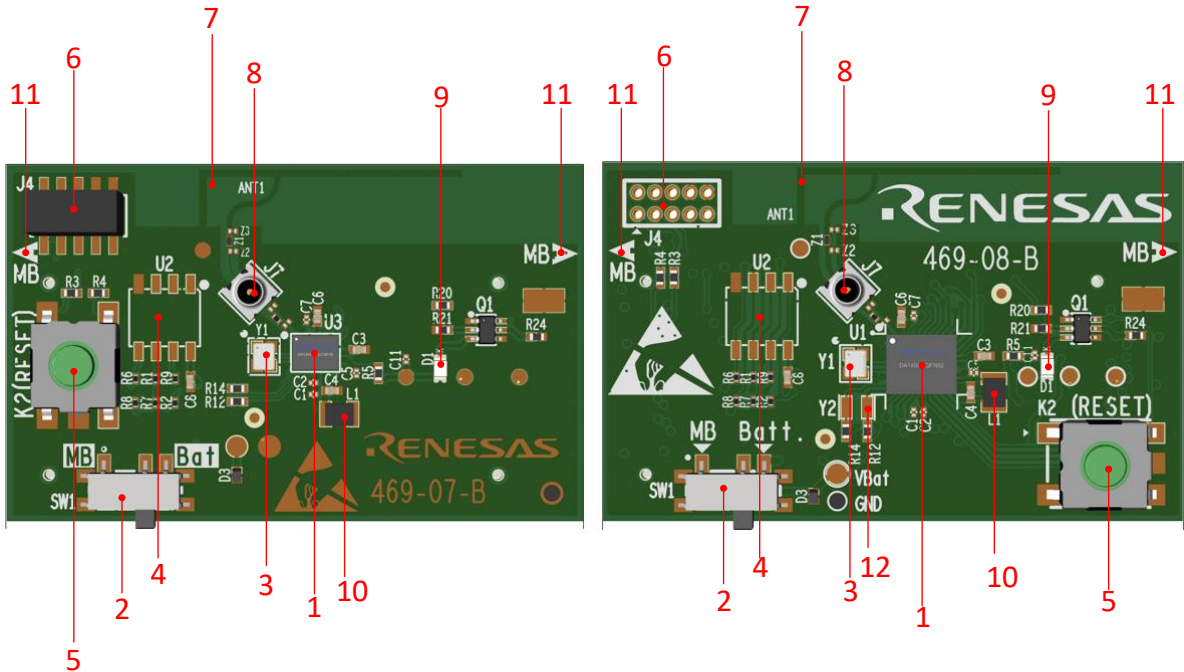

Figure 6. TOP side, WLCSP39 Pro-DB (left), FCQFN52 Pro-DB (right)

DA1459x Pro-Development Kit

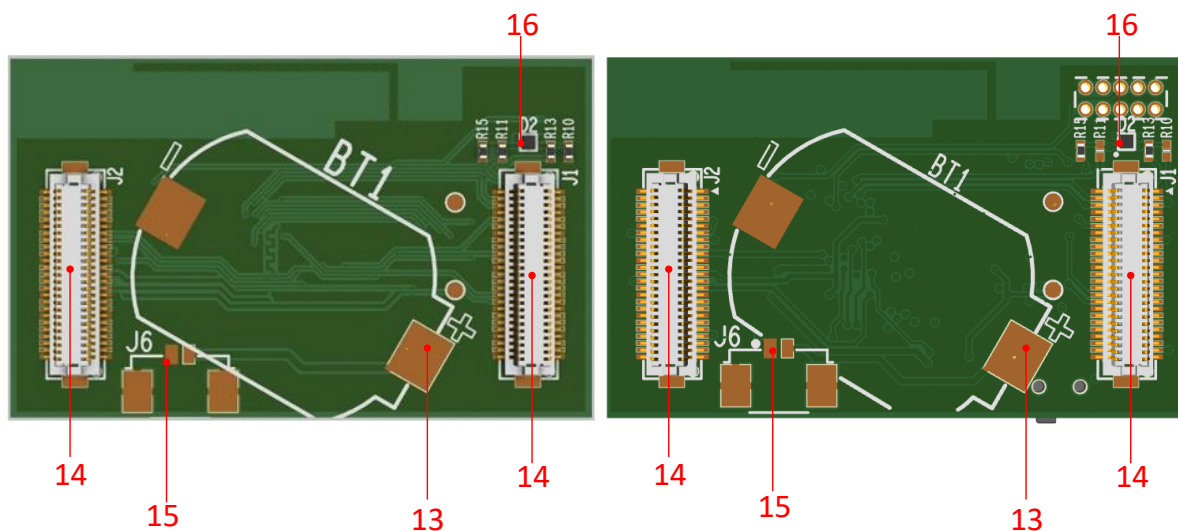

Figure 7. BOTTOM side, WLCSP39 Pro-DB (left), FCQFN52 Pro-DB (right)

1. DA1459x SoC
2. Power Switch, (SW1)
3. 32 MHz crystal (Y1)
4. External QSPI memory (U2)
5. Reset push button (K2)
6. Debugging connector (J4)
7. Printed antenna
8. RF electromechanical switch (J7)
9. LED (D1)
10. Power inductor (L1)
11. Mounting marking
12. 32 kHz crystal (Y2) – applied (not populated) only for FCQFN52 package.
13. Place holder for Coin cell Battery (BT1)
14. Mating connectors to Pro-MB (J1, J2)
15. Place holder for 2-pins battery connector (J6)
16. ESD diode for Debugging connector.

4.2.1.1 WLCSP39 based Pro-Daughterboard

Signals of DA14592 WLCSP39 (da1459x-db-wlcs39_469-07-x) are routed to J1, J2 interface board (mating) connectors on the DA1459x Daughterboard. See [Figure 8](#).

DA1459x Pro-Development Kit

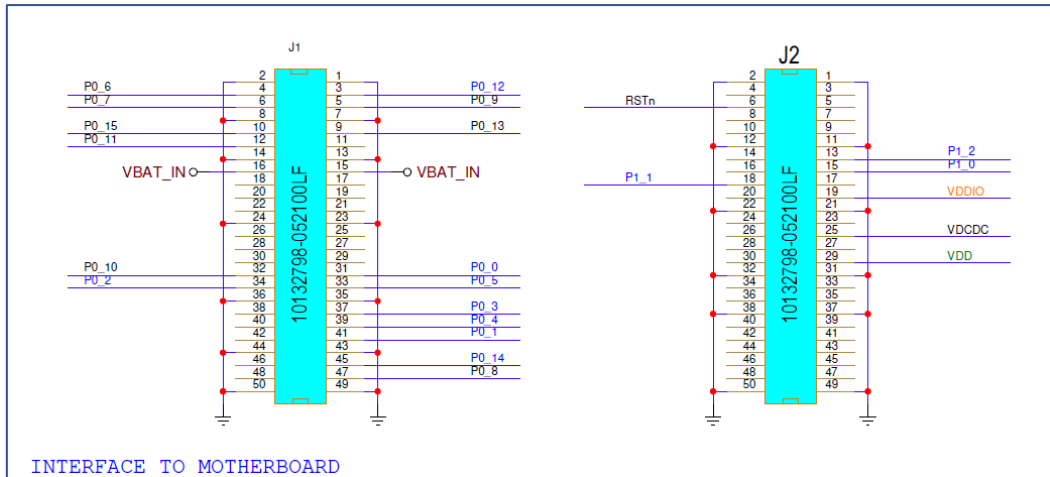

Figure 8. DA1459x Interface header of WLCSP39 to DA1459x Pro-Motherboard

Signals of DA1459x WLCSP39 are mapped to Pro-Motherboard.

Table 3 describes the mapping of the signals.

Table 3. DA1459x WLCSP39 pins assignment

GPIO	GPIO multiplexing	Devkit Function	MikroBUS	PMOD
P0_0	QSPI_CLK		SCK	SCK
P0_1	QSPI_CS	TRIG_5	CS1#	
P0_2	QSPI_D0		MOSI	MOSI
P0_3	QSPI_D1		MISO	MISO
P0_4	QSPI_D2		INT1	
P0_5	QSPI_D3		RST1#	
P0_6	M33_SWDIO	SWDIO		
P0_7	M33_SWCLK	SWCLK		
P0_8	CMAC_SWDIO/DIVN	TRIG_1		INT2
P0_9	CMAC_SWCLK			RST2#
P0_10	PWM_2/GPADC_2/SDADC_2	BUTTON/DTRIG_0	AN	
P0_11	XTAL32M	UCTS		CS1#
P0_12	LPCLK/PWM_1	TRIG_4	PWM	
P0_13	BOOT_UART_TX	UTX		
P0_14	WAKEUP_1	TRIG_6	SCL	SCL
P0_15	BOOT_UART_RX	URX	RX	
P1_0	PGA_INp/GPADC_0/SDADC_0	URTS	TX	
P1_1	PGA_INn/GPADC_1/SDADC_1	TRIG_2		
P1_2	RC32M/GPADC_3/SDADC_3	TRIG_3	SDA	SDA

4.2.1.2 FCQFN52 based Pro-Daughterboard

Signals of DA1459x FCQFN52 (da1459x_db_fcqfn52_469-08-x) are routed to J1, J2 interface board (mating) connectors on the DA1459x Daughterboard. See Figure 9.

DA1459x Pro-Development Kit

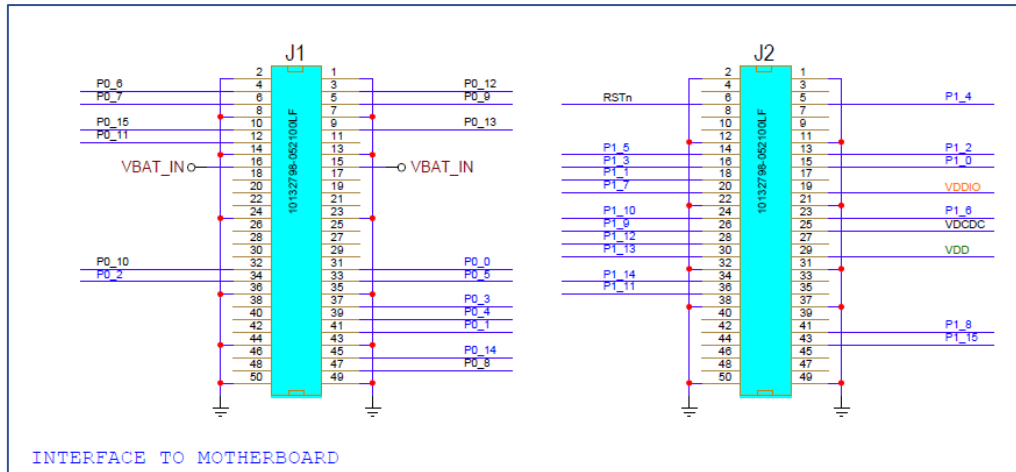

Figure 9. DA1459x Interface header of FCQFN52 to DA1459x Pro-Motherboard

Signals of DA1459x FCQFN52 are mapped to DA1459x Pro-Motherboard. Table 4 describes the mapping of the signals.

Table 4. DA1459x FCQFN52 pins assignment

GPIO	GPIO multiplexing	Devkit function	MikroBUS	PMOD	DBs mating headers J1 and J2 (Note 1)
P0_0	QSPI_CLK		SCK	SCK	J1.31
P0_1	QSPI_CS	TRIG_5	CS1#		J1.41
P0_2	QSPI_D0		MOSI	MOSI	J1.34
P0_3	QSPI_D1		MISO	MISO	J1.37
P0_4	QSPI_D2		INT1		J1.39
P0_5	QSPI_D3		RST1#		J1.33
P0_6	M33_SWDIO	SWDIO			J1.4
P0_7	M33_SWCLK	SWCLK			J1.6
P0_8	CMAC_SWDIO/DIVN	TRIG_1		INT2	J1.47
P0_9	CMAC_SWCLK			RST2#	J1.5
P0_10	PWM_2/GPADC_2/SDADC_2	BUTTON / TRIG_0	AN		J1.32
P0_11	XTAL32M	UCTS		CS1#	J1.12
P0_12	LPCLK/PWM_1	TRIG_4	PWM		J1.3
P0_13	BOOT_UART_TX	UTX			J1.09
P0_14	WAKEUP_1	TRIG_6	SCL	SCL	J1.45
P0_15	BOOT_UART_RX	URX	RX		J1.10
P1_0	PGA_INp/GPADC_0/SDADC_0	URTS	TX		J2.15
P1_1	PGA_INn/GPADC_1/SDADC_1	TRIG_2			J2.18
P1_2	RC32M/GPADC_3/SDADC_3	TRIG_3	SDA	SDA	J2.13
P1_3					J2.16
P1_4	WAKEUP_2	TRIG_7			J2.5

DA1459x Pro-Development Kit

GPIO	GPIO multiplexing	Devkit function	MikroBUS	PMOD	DBs mating headers J1 and J2 (Note 1)
P1_5	GPADC_4 / SDADC_4 / SDADC_REFp/ SDADC_INT_REF				J2.14
P1_6	GPADC_5/SDADC_5/SDADC_REFn				J2.23
P1_7					J2.20
P1_8					J2.41
P1_9	GPADC_6/SDADC_6				J2.26
P1_10					J2.24
P1_11	GPADC_7/SDADC_7				J2.36
P1_12					J2.28
P1_13	XTAL32km				J2.30
P1_14	XTAL32kp				J2.34
P1_15					J2.43

Note 1 QSPI (GPIO) pads input voltage must not exceed VDDIO voltage level since there is no backdrive protection on those pads.

4.2.2 XTAL, 32 MHz (Y1)

The main clock of the system is generated from a 32 MHz crystal which is connected to the internal crystal oscillator of DA1459x SoC.

The crystal used is the Murata XRCGB32M000F1H00R0 or XRCGB32M000F1S1AR0.

Table 5. Crystal specification

Item	Specification
Nominal Frequency	32.0000 MHz
Frequency Tolerance	±10 ppm max.
Frequency Shift by Temperature	±10 ppm/max. from initial value (-30 to +85°C)
Frequency Aging	±2 ppm max/year
Equivalent Series Resistance	60 Ω max. or 50 Ω max ⁽¹⁾
Load Capacitance	6.0±0.1 pF
Operating Temperature Range	-30 to +85°C
Size	2.0 x 1.6 mm

Note 1 60 Ω for XRCGB32M000F1H00R0
50 Ω for XRCGB32M000F1S1AR0

4.2.3 XTAL, 32 kHz (Y2)

An optional 32kHz external crystal can be placed on the daughterboard. This crystal is not mandatory as there is an internal RCX oscillator in DA1459x that can be used instead. In WLCSP Pro-daughterboard this crystal is not placed, while in FCQFN daughterboard there is a placeholder, but crystal is not populated.

4.2.4 Debugging connector (J4)

On both daughterboards there is an optional JTAG connector that can be used for debugging via SWD or for communication via UART.

DA1459x Pro-Development Kit

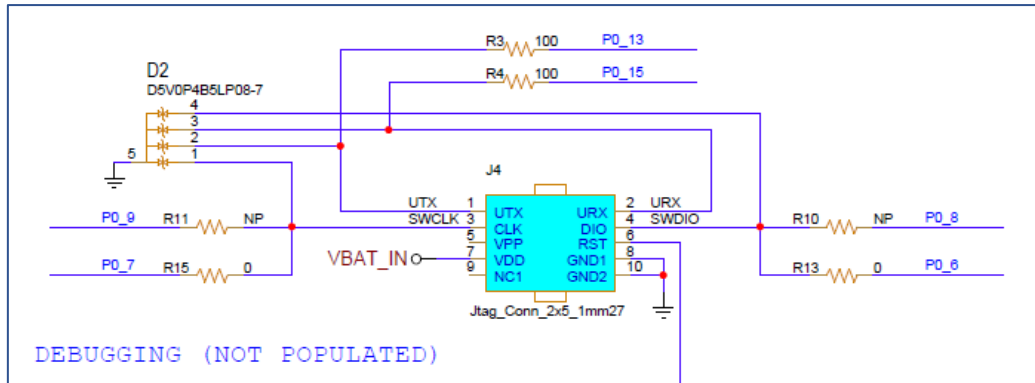

Figure 10. The debugging header, J4

As described in the datasheet, DA1459x contains two processors, an ARM Cortex-M33™ and an ARM Cortex-M0+™. Both processors can be accessed from J4, through their SWD bus. By default, the SWD of M33 is enabled. For enabling SWD bus of M0+, two resistors must be removed (R10, R15) and two others to be mounted (R11, R13).

Table 6. Debugging header – pins assignment

Pin No	Pin Function	Default Signals	Optional Signals	Comments
1	UTX	P0_13		Through 100 Ω
2	URX	P0_15		Through 100 Ω
3	SWCLK	P0_7 (SWCLK_M33)	P0_9 (SWCLK_M0+)	To Enable optional signal: solder R11/remove R15
4	SWDIO	P0_6 (SWDIO_M33)	P0_8 (SWDIO_M0+)	To Enable optional signal: solder R13/remove R10
5	VPP	No Connect		
6	RST	RST		Driven to DA14592 through inverter
7	VDD	VBAT_IN		
8	GND	GND		
9	No Connect	No Connect		
10	GND	GND		

SWD of M33 is also connected to the Pro-Motherboard onboard J-Link debugger. Consequently, by enabling the SWD of M0+ connectivity on J4, you can access both processors (M33 and M0+) of DA14592.

4.2.5 QSPI external memory (U2)

On both daughterboards an optional external QSPI memory place holder, U2 is applied. This is a footprint for a SOP-8, 150 mils. By default, it is not populated as DA1459x contains an embedded flash memory.

DA1459x Pro-Development Kit

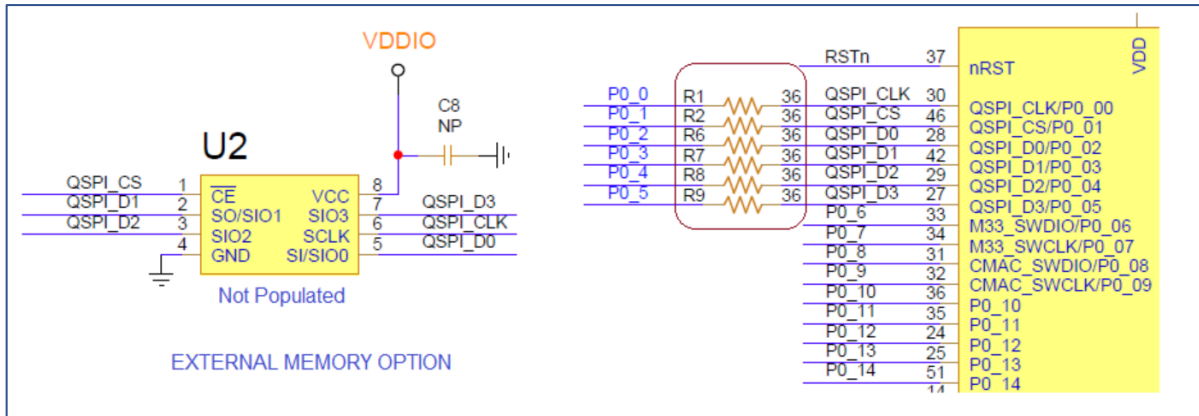

Figure 11. The External QSPI memory, (U2) place holder

On the Software Development Kit (SDK) the following components are supported:

- Macronix MX25U3235, 32 MBit
- Winbond W25Q32JWIM, 32 MBit
- Winbond W25Q32JWIQ, 32 MBit

For enabling the external memory option, user can populate U2, C8 (=1 μF) and remove resistors R1, R2 and R6 to R9 (=36 Ω) for isolating memory from Pro-Motherboard.

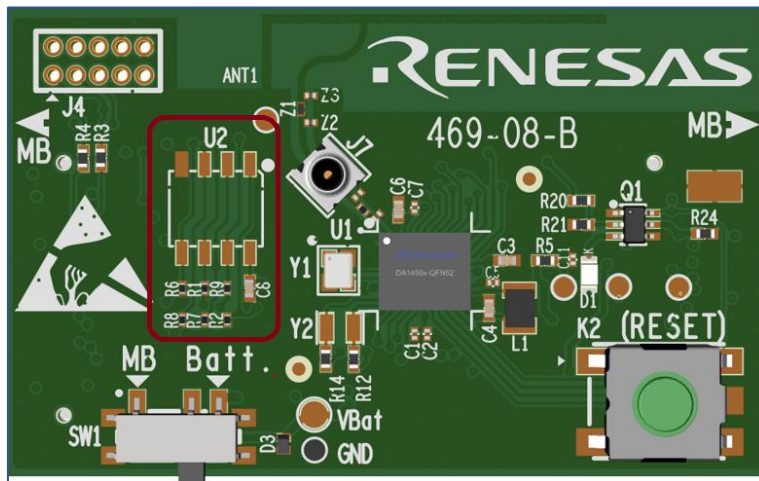

Figure 12. External Memory placeholder and the components

4.2.6 General purpose LED (D1)

On both daughterboards there is one red led (D1) that can be used for optical indications. LED is driven from P1_1 through a N-FET.

DA1459x Pro-Development Kit

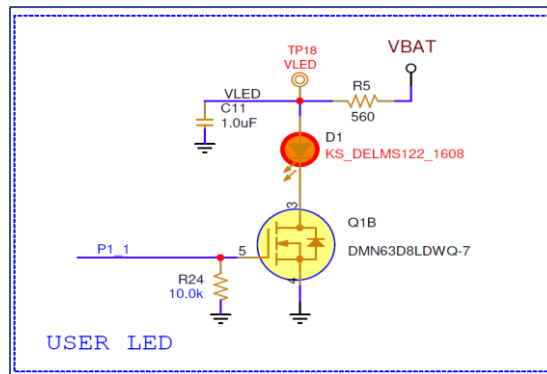

Figure 13. Red LED (D1) circuitry

4.2.7 The RESET on DA14592 Pro-Daughterboard

Reset is active low. If it is not driven low, nRst pin of DA14592 is set high by an internal pull up, 25 K, to VBAT_IN.

On DA1459x Pro Devkit, there are four ways for activating Reset.

- By pressing button (K2).
- Through Debugger connector J4. As the Reset signal of J4 is active high, a nFET is added.
- Through T-Reset signal on DA1459x Pro-Motherboard, see Section 4.3.6. This connected directly (wired-OR) to DA1459x chip pin.
- Through U_RSTn signal on DA1459x Pro-Motherboard, see Section 4.3.6. This signal is tied together with T_Reset and connected directly (wired-OR) to DA1459x chip pin. This option requires additional software. By default, it is not enabled.

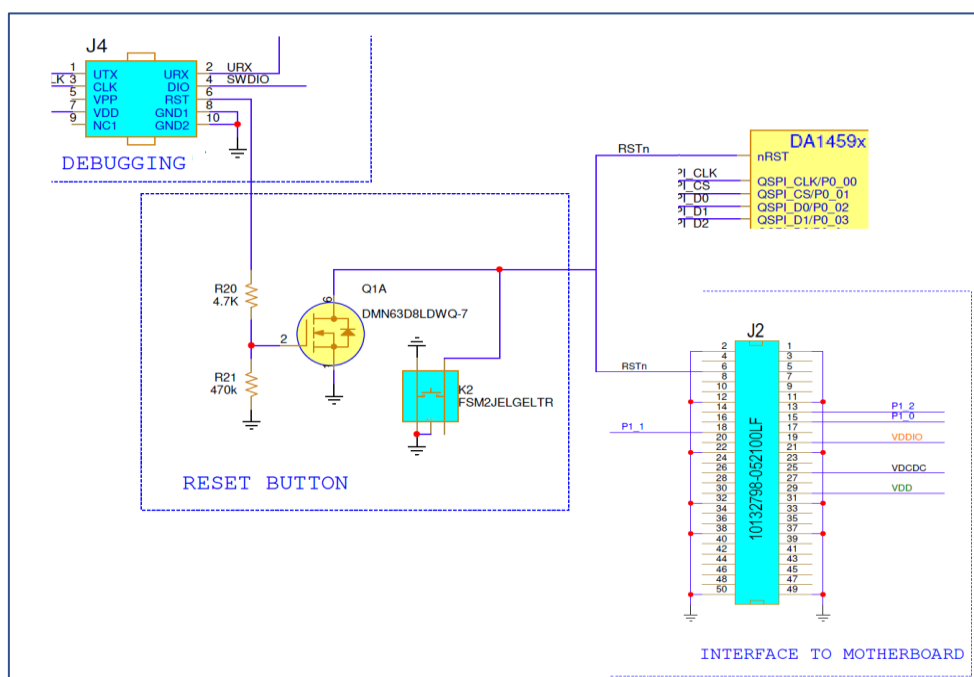

Figure 14. Reset circuitry on Pro-Daughterboard

4.2.8 Power section of DA14592 Pro-Daughterboard

The DA14592 has a complete integrated Power Management Unit (PMU). This includes a buck DC-DC converter and several LDOs for the different power rails of the system. Voltage rails are:

DA1459x Pro-Development Kit

- VBAT: input voltage of the DA14592 SoC. VBAT is provided either from Pro-Motherboard or a battery. Selection is done from SW1.
- VDCDC: produced from internal synchronous Single Inductance (L1) Single Output Buck DC-DC converter with programmable output 1.1 V to 1.4 VDCDC.
- VDD: LDO (active and retention) for the digital core with 20 mA (2 mA on retention) driving capability.
- VDDIO: LDO (active and retention) for the I/O-s with bypass functionality of 1.8 V voltage range.

Figure 15 shows the configuration of PMU on daughterboard.

The power section consists of a Switch (SW1) that can be used for selecting a power supply source for the chip.

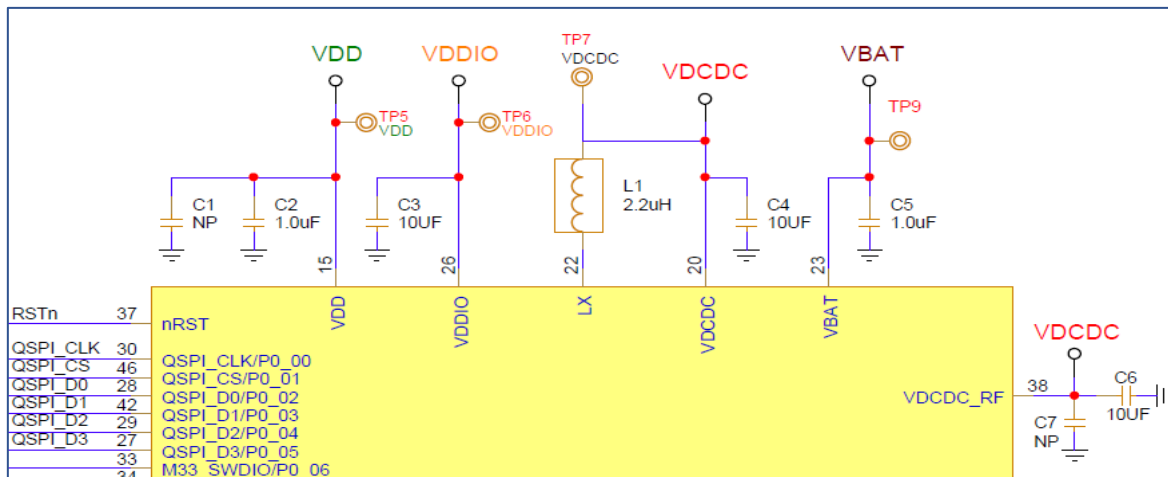

Figure 15. DA14592 SoC, power pins

There are two options available:

- Supply from LDO on Pro motherboard by setting SW1 to **MB**, see Figure 16,
 - Supply directly from Battery by setting SW1 to **Bat** see Figure 16
- Two Battery options are available:
- Place holder for a Coin cell 2016 lithium battery socket (BT1) on the bottom layer of each daughterboard. (Figure 16)
 - Place holder for a two pins Battery connector (J6).

NOTE

Do not use a LiPo battery because its voltage can go higher than 3.6 V and this can damage DA1459x SoC. Absolute maximum voltage of VBAT pin of DA14592 is 3.6 V.

DA1459x Pro-Development Kit

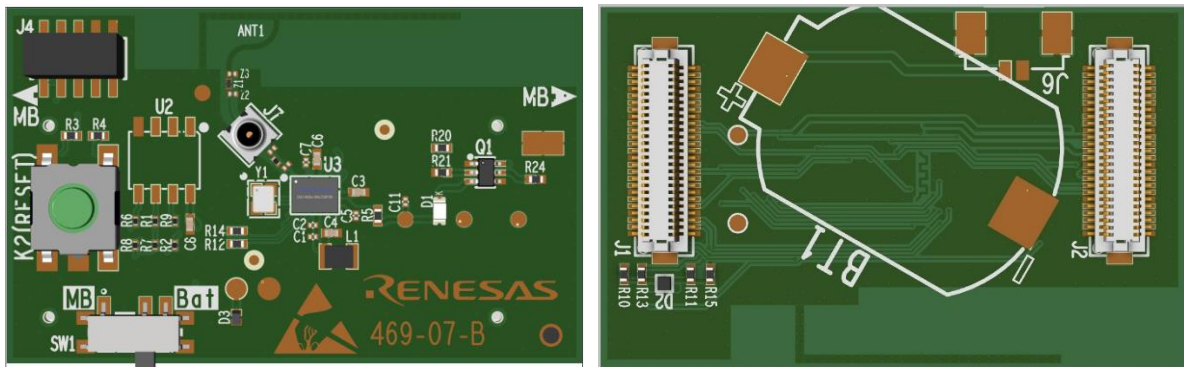

Figure 16. SW1 (left), available battery sockets on the bottom side of the daughterboards (right)

4.2.9 RF section

The RF section consists of a printed antenna, a matching circuit, a Low Pass Filter (LPF), and an RF coaxial switch that can be used for conducted RF measurements instead of the antenna. If a cable is connected on the RF coaxial switch, then the antenna gets disconnected from the chip.

The DA1459x RFIO pin is connected to the printed antenna through a 50 Ω RF stripline, an LPF and a matching circuit.

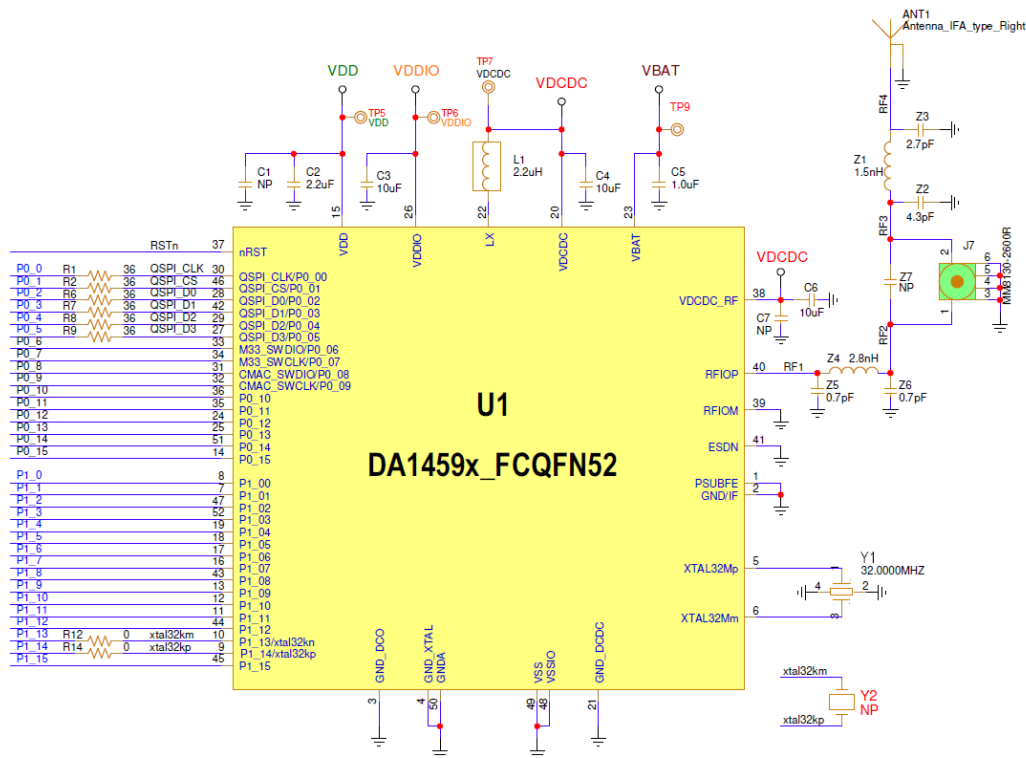

Figure 17. RF section of DA14592 Pro-DB

RF coaxial connector J7, is the Murata MM8130-2600RB8. You must use an appropriate mating coaxial cable to SMA, (MXHS83QE3000).

DA1459x Pro-Development Kit

4.3 DA1459x Pro-MB

The Pro-motherboard, with design name DA1459x-mb-pro and reference number 469-16-D, hosts the DA1459x Pro Daughterboard as well as the components which are required for evaluation and software development. Figure 18 shows Pro Motherboards main blocks.

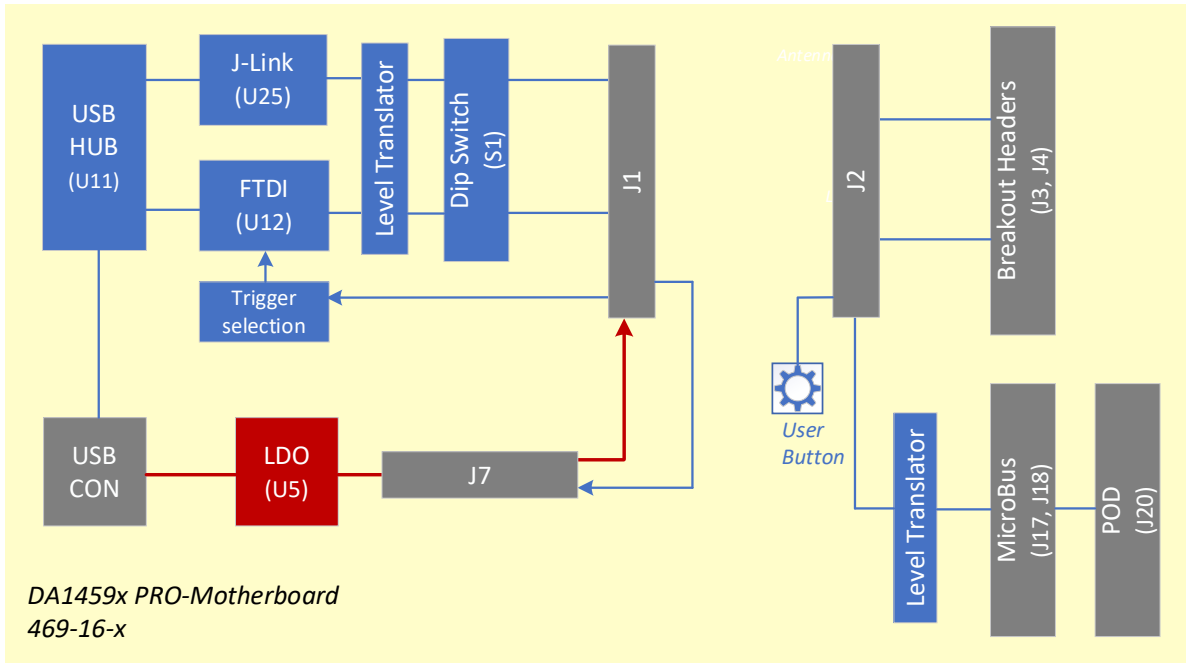

Figure 18. DA1459x Pro-Motherboard block diagram

- Pro Daughterboard mating headers (J1 and J2)
- Power section and Power Measurement Module (PMM2) daughterboard for measuring the current that DA1459x draws (it needs Smart Snippets toolbox)
- FTDI chip for UART communication between DA1459x and the PC
- MCU SEGGER chip for SWD debugging through Jlink
- DIP switch (S1) for allowing communication with FTDI and SEGGER
- Breakout headers (J3 and J4) for exposing the DA1459x GPIOs
- MikroBUS (J17 and J18) and PMOD (J20) interfaces – parallel connected
- General purpose push button
- Configuration headers.

DA1459x Pro-Development Kit

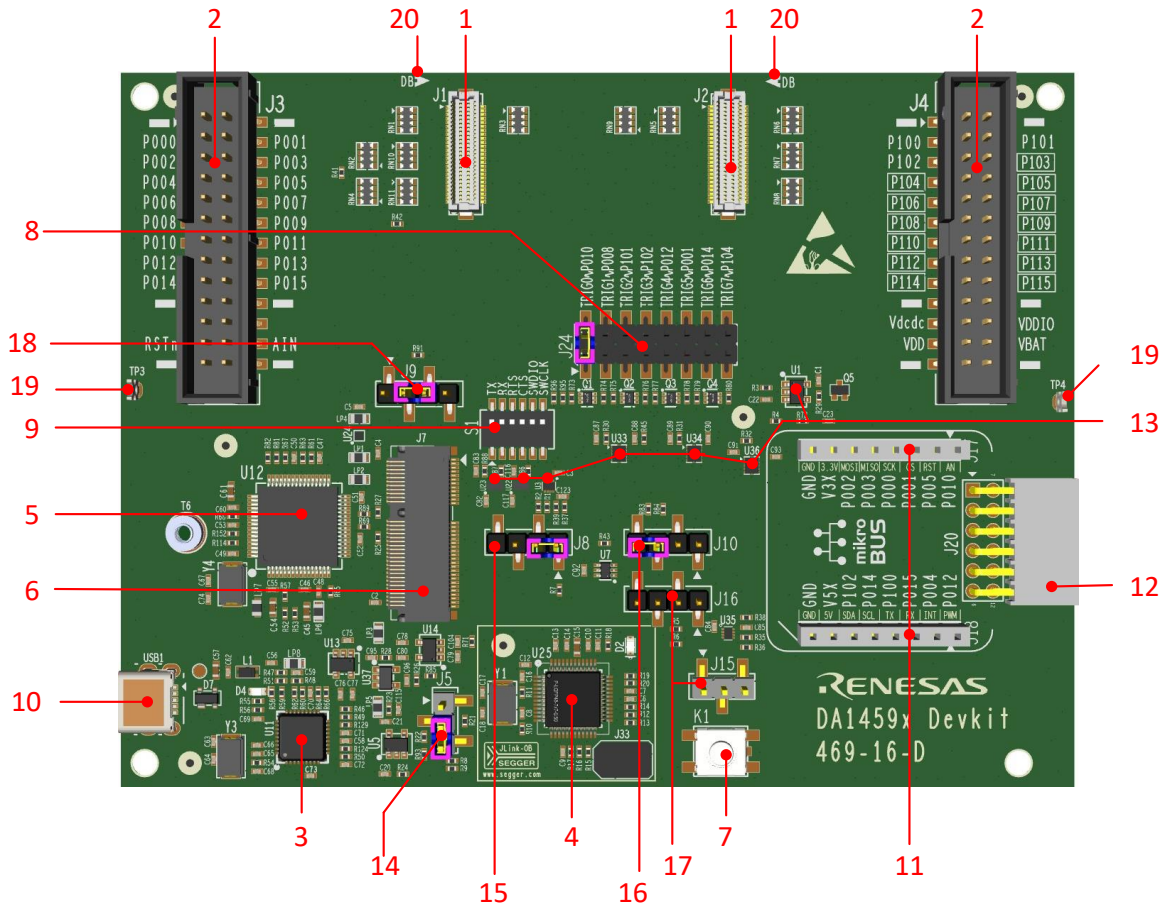

Figure 19. DA1459x Pro-Motherboard, 469-16-x

- | | |
|---|---|
| <ol style="list-style-type: none"> 1. Daughterboard Mating Headers, J1 and J2 2. Breakout Header, J3 and J4 3. USB HUB, U11 4. USB to SWD (Segger), U25 5. USB to UART, U12 6. PMM2 Mounting Connector, J7 7. Push Button, K1 8. Digital Trigger Header, J24 9. Debug Section Dip Switches, S1 10. USB port, USB1 | <ol style="list-style-type: none"> 11. MikroBus Connectors, J17 and J18 12. PMOD Connector, J20 13. Level Translators 14. Header of Power Supply options, J5 15. Header of Push Button enable and LDO_EN, J8 16. Header of Reset Options, J10 17. Header for Enabling Level Translators for I2C of Mikrobus and PMOD, J15 and J16 18. Header of PMM2 Enable, J9 19. GND pins, TP3 and TP4 20. Daughterboard alignment Mark. |
|---|---|

4.3.1 DA1459x signals distribution on Pro-Motherboard

The signals of DA1459x are routed to Pro-Daughterboard through J1, J2 mating connectors, and they are distributed into the Pro-Motherboard. They are either used for debugging purposes or they are connected to Mikrobus/PMOD interfaces. All signals are exposed to break out headers for monitoring purposes.

Table 7 describes the mapping of Signals of DA1459x on Pro-Motherboard.

DA1459x Pro-Development Kit
Table 7. DA1459x signal connectivity on Pro-Motherboard

GPIO	GPIO multiplexing	Devkit function	MikroBUS	PMOD	DBs mating headers J1 and J2	Breakout headers J3 and J4
P0_0	QSPI_CLK		SCK	SCK	J1.31	J3.3
P0_1	QSPI_CS	TRIG_5	CS1#		J1.41	J3.4
P0_2	QSPI_D0		MOSI	MOSI	J1.34	J3.5
P0_3	QSPI_D1		MISO	MISO	J1.37	J3.6
P0_4	QSPI_D2		INT1		J1.39	J3.7
P0_5	QSPI_D3		RST1#		J1.33	J3.8
P0_6	M33_SWDIO	SWDIO			J1.4	J3.9
P0_7	M33_SWCLK	SWCLK			J1.6	J3.10
P0_8	CMAC_SWDIO/DIVN	TRIG_1		INT2	J1.47	J3.11
P0_9	CMAC_SWCLK			RST2#	J1.5	J3.12
P0_10	PWM_2/GPADC_2/SDADC_2	BUTTON / TRIG_0	AN		J1.32	J3.13
P0_11	XTAL32M	UCTS			J1.12	J3.14
P0_12	LPCLK/PWM_1	TRIG_4	PWM		J1.3	J3.15
P0_13	BOOT_UART_TX	UTX			J1.09	J3.16
P0_14	WAKEUP_1	TRIG_6	SCL	SCL	J1.45	J3.17
P0_15	BOOT_UART_RX	URX	RX		J1.10	J3.18
P1_0	PGA_INp/GPADC_0/SDADC_0	URTS	TX		J2.15	J4.3
P1_1	PGA_INn/GPADC_1/SDADC_1	TRIG_2			J2.18	J4.4
P1_2	RC32M/GPADC_3/SDADC_3	TRIG_3	SDA	SDA	J2.13	J4.5
P1_3					J2.16	J4.6
P1_4	WAKEUP_2	TRIG_7			J2.5	J4.7
P1_5	GPADC_4 / SDADC_4 / SDADC_REFp/ SDADC_INT_REF				J2.14	J4.8
P1_6	GPADC_5/SDADC_5/ SDADC_REFn				J2.23	J4.9
P1_7					J2.20	J4.10
P1_8					J2.41	J4.11
P1_9	GPADC_6/SDADC_6				J2.26	J4.12
P1_10					J2.24	J4.13
P1_11	GPADC_7/SDADC_7				J2.36	J4.14
P1_12					J2.28	J4.15
P1_13	XTAL32km				J2.30	J4.16
P1_14	XTAL32kp				J2.34	J4.17
P1_15					J2.43	J4.18

DA1459x Pro-Development Kit

4.3.2 USB port (USB1) and USB HUB (U11)

DA1459x Devkit power and data port is the USB connector USB1. This is a mini-USB connector. Power connection is protected from surges with a Common Mode Choke whereas data connections are protected with ESD diodes.

The USB HUB of DA1459x Pro-MB is implemented by U11, USB2512B. This chip is supplied with 3.3 V from U13.

The signal PWR_ENABLE is generated from U11 and it is an active high signal. It enables the power components (LDOs and DC-DC converter) for UART, JTAG, and the current sensing circuit. The system powers up only after the USB HUB has enumerated properly. PWR_ENABLE signal can be manually activated by adding a jumper between positions 3 and 4 of header J8.

Its operation is indicated through the green LED D4 on DA1459x Pro-MB. A 24 MHz crystal (Y3) is required for chip operation.

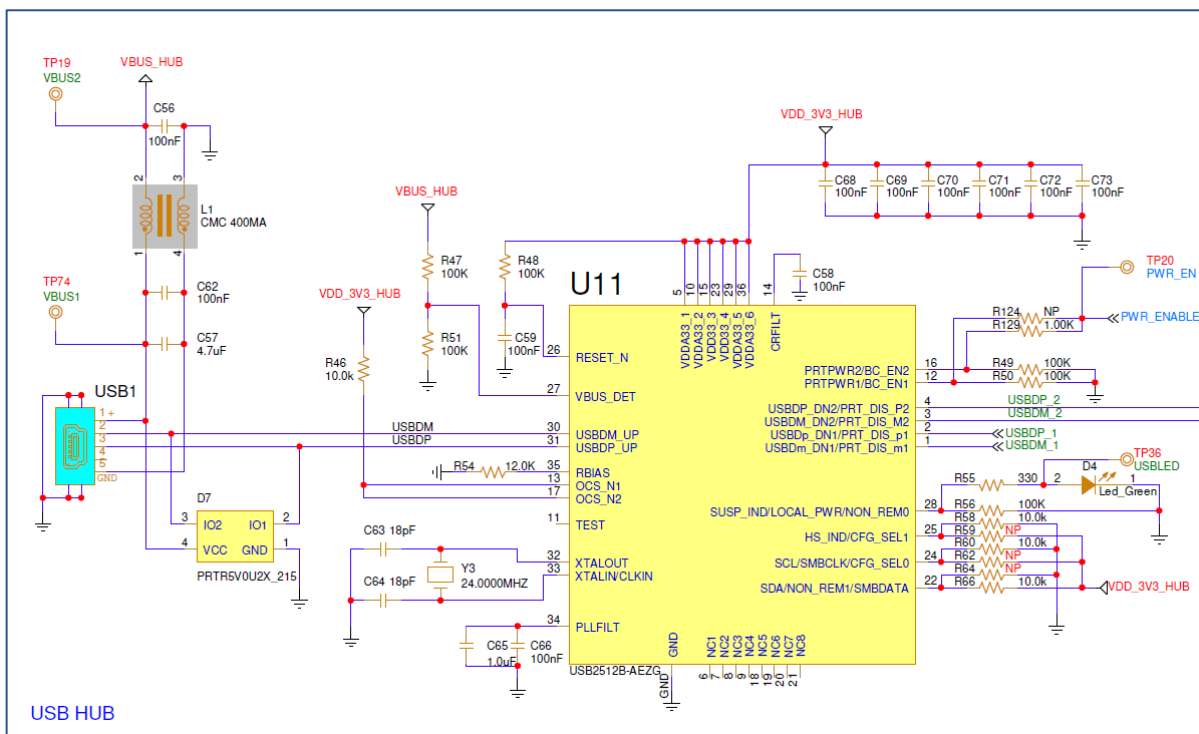

Figure 20. USB HUB circuitry of DA14531 Pro-MB

4.3.3 USB to UART (U12)

The USB to UART function is implemented by U12, FT2232HL. This chip is supplied with 3.3 V from U14. A 12 MHz crystal (Y4) is required for the chip operation. U12 is connected to the USB hub.

Functions served by U12 are the following:

- Connecting a PC to the UART port of DA1459x SoC. This is a Full UART which is connected to DA1459x through Dip Switch (S1) and level translators.
- Connecting a PC to the current sensing circuitry:
 - SPI connection with PMM2
 - Connection to 8 software triggers, including the software cursor triggering (TRIG_3 / P1_02) as defined in the Software Development Kit (SDK).
- Reset capability of the DA1459x SoC through the U_RSTn signal (not enabled).

DA1459x Pro-Development Kit

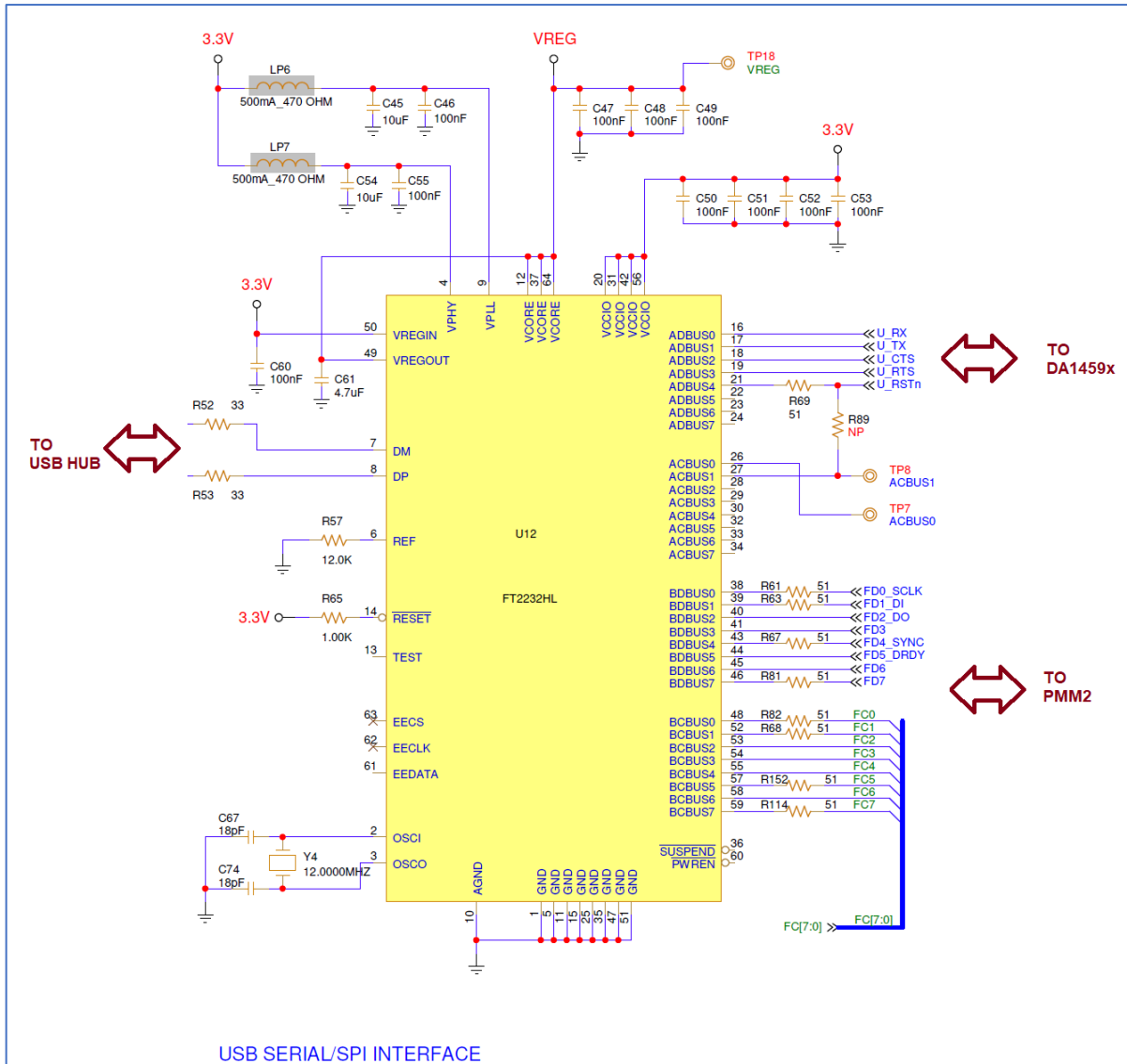

Figure 21. USB to UART (U12)

4.3.4 USB to SWD (U5)

The USB to SWD function is implemented by U5, R7FA4M2AD3CFL. On the Flash of U5, the JLink-OB firmware from SEGGER is loaded. Its operation is indicated via the green LED D2 on the DA1459x Pro-MB. This chip is supplied with 3.3 V from U14. U14 is enabled by the PWR_ENABLE signal.

Functions served by U5 include:

- Connecting a PC to the SWD port of DA1459x SoC
- Reset capability of the DA1459x SoC through the T_RESET signal.

DA1459x Pro-Development Kit

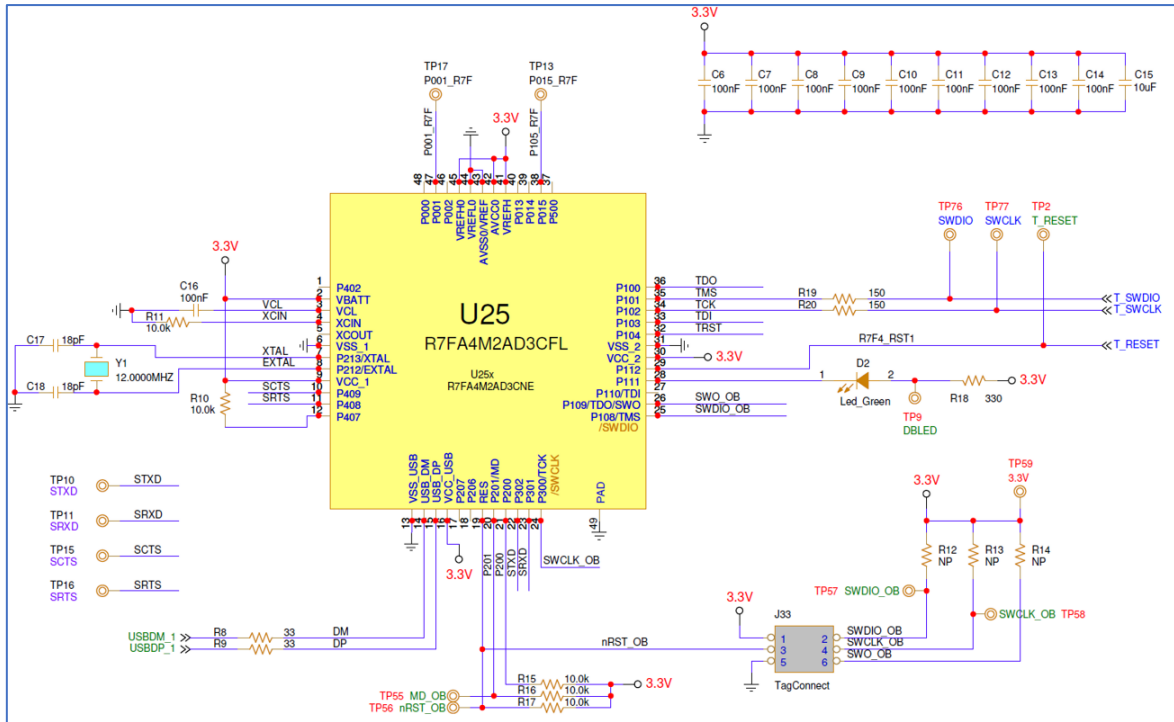

Figure 22. USB to SWD (U4)

4.3.5 Debugging signals, DIP switch, and Level translation

On Pro-motherboard there is a DIP switch (S1) that can connect or disconnect the DA1459x UART and SWD signals from the FTDI and SEGGER, respectively. Table 8 shows the mapping of these signals.

Table 8. Signal mapping on DIP switch (S1)

Pin name	Signal name
P0_10	SWDIO
P0_11	SWCLK
P0_9	UTX
P0_8	URX
P1_0	URTS
P0_7	UCTS

DEBUG INTERFACE

All the signals that are mapped on the DIP switch require voltage translation for avoiding leakage through the pins because the DA1459x I/O voltage is set to 1.8 V voltage range (LDO_IO) whereas the other side (on board interfaces, JTAG / UART) is fixed at 3.3 V, (Figure 23).

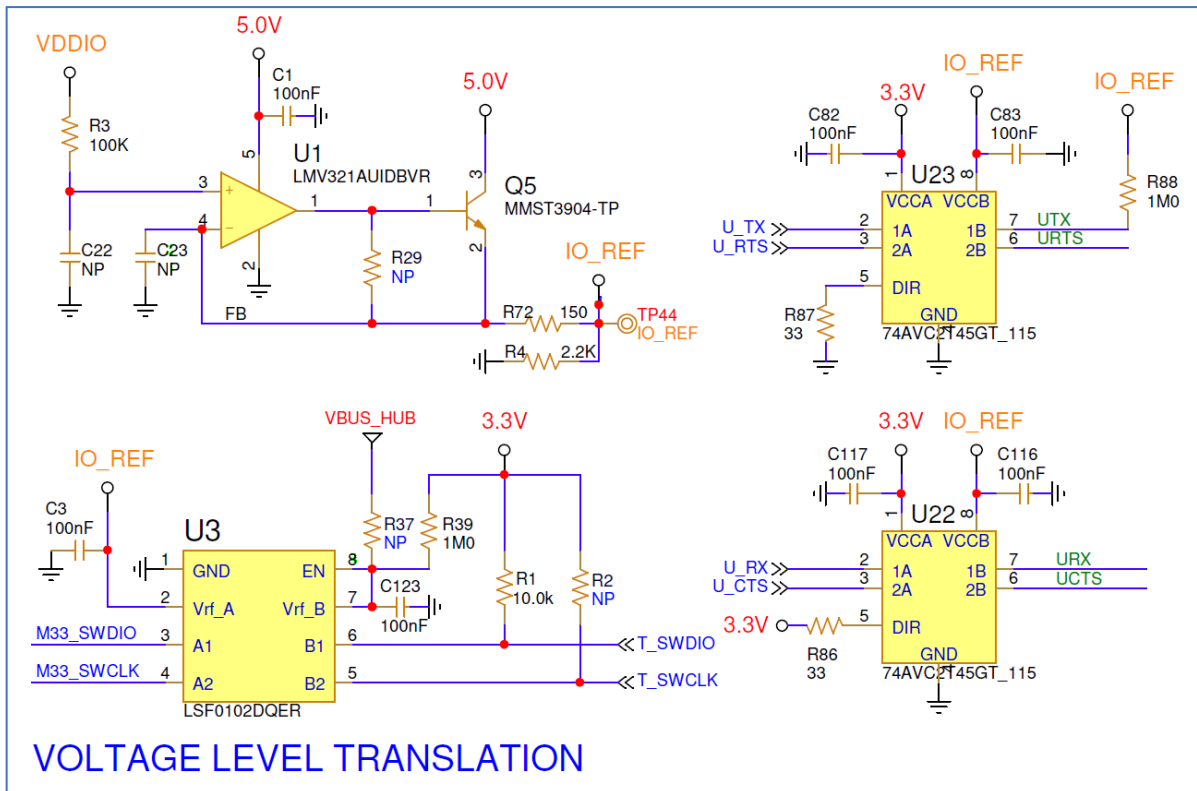

Figure 23. Voltage level translation circuit

IO_REF is a buffered version of the voltage used in the DA1459x side I/O. This voltage rail powers a dual buffer gate (U22) with direction from motherboard to DA1459x pins, and also on DA1459x side the single bidirectional transceiver used for SWDIO (U3).

The direction from DA1459x to the motherboard is handled by U23, powered from the motherboard 3.3 V.

4.3.6 Reset

The reset (RSTn) of DA14592x is active low, and in general, there are four ways for being activated:

- On DA1459x Pro-Daughterboard:
 - Press the **Push** button (K2) on Pro_DB, see [Figure 14](#)
 - Enable external signal on pin6 of J4 on Pro_DB, see [Figure 10](#)
- On DA1459x Pro-Motherboard:
 - Enable T_RESET on Pro_MB. This signal is connected to pin28 of U25 and it is controlled from the J-Link debugger. To enable it, place a jumper on header J10 between pins 3 and 4.
 - Enable U_RSTn on Pro_MB. U_RSTn is driven from the USB to UART chip (U12). It is connected to ADBUS4 (default) or ACBUS1. These pins must be actively controlled by software.
 - URSTn function is not enabled by default. Consequently, the jumper of J10 between pins 1 and 2 must not be placed or the DA1459x may go to reset condition.

DA1459x Pro-Development Kit

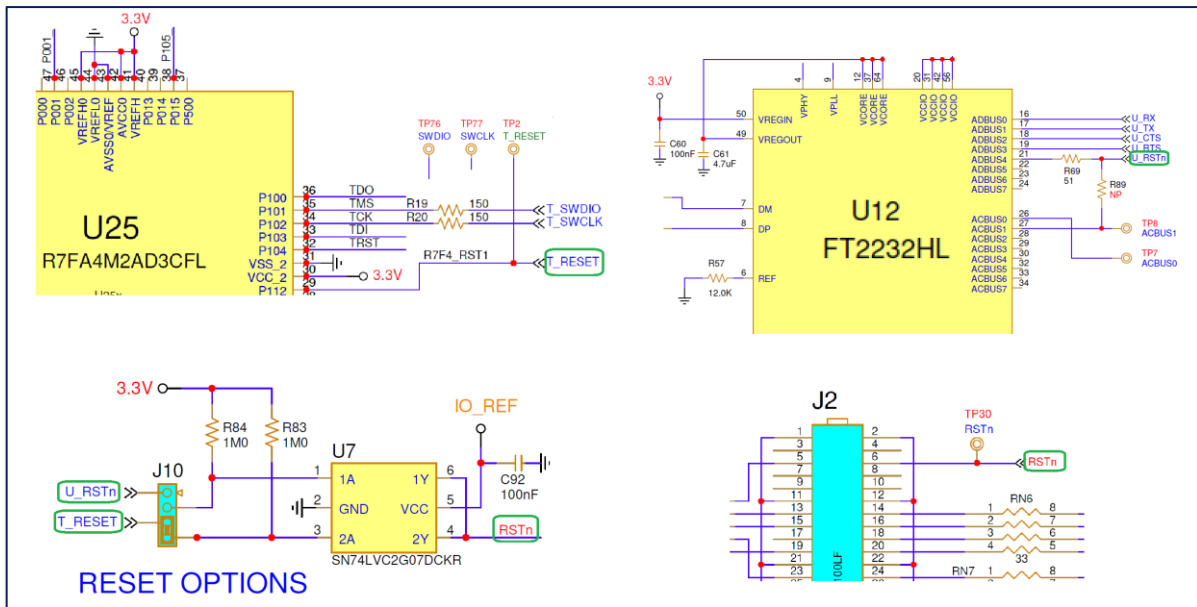

Figure 24. RESET circuit on DA1459x Pro-MB

4.3.7 Push button (K1)

A general-purpose push button, K1 is applied on DA1459x Pro_MB.

Press the **Push** button to drive P0_10 to GND through 1kΩ resistor (R7). The Push button logic is active low and its operation is hardware enabled (default) from header J8, pins 1 and 2.

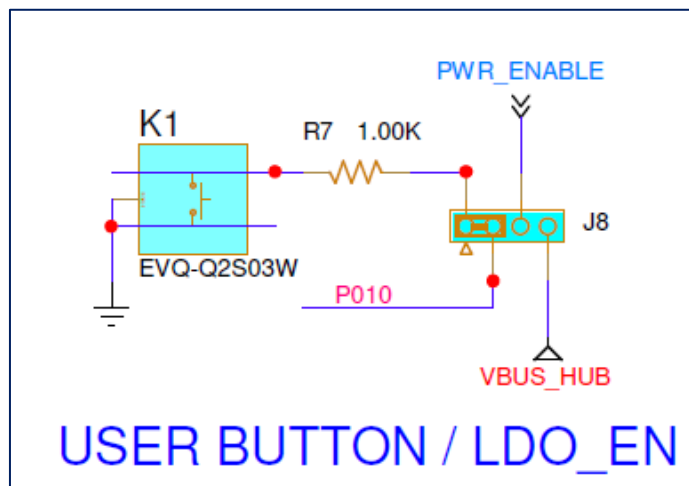

Figure 25. General purpose Push button K1

4.3.8 MikroBUS and PMOD interface

MikroBUS and PMOD share the same signals, except reset, chip select, and interrupt. This means that either MikroBUS or PMOD can be used. Since DA1459x IO-signal level is 1.8 V, voltage translators were added for the MikroBUS and PMOD signals. The connections of I2C signals are controlled by headers J15 and J16 (by default disabled). Termination resistors (33 Ω) are applied between level translators and DA1459x Pro-daughterboard.

MikroBus is supplied by V5P, a 4.5 V voltage rail, which is produced from U37. Both Mikrobus and PMOD are supplied by V3X, a 3.3 V voltage rail. The current drawn from V3X can be monitored from PMM2.

DA1459x Pro-Development Kit

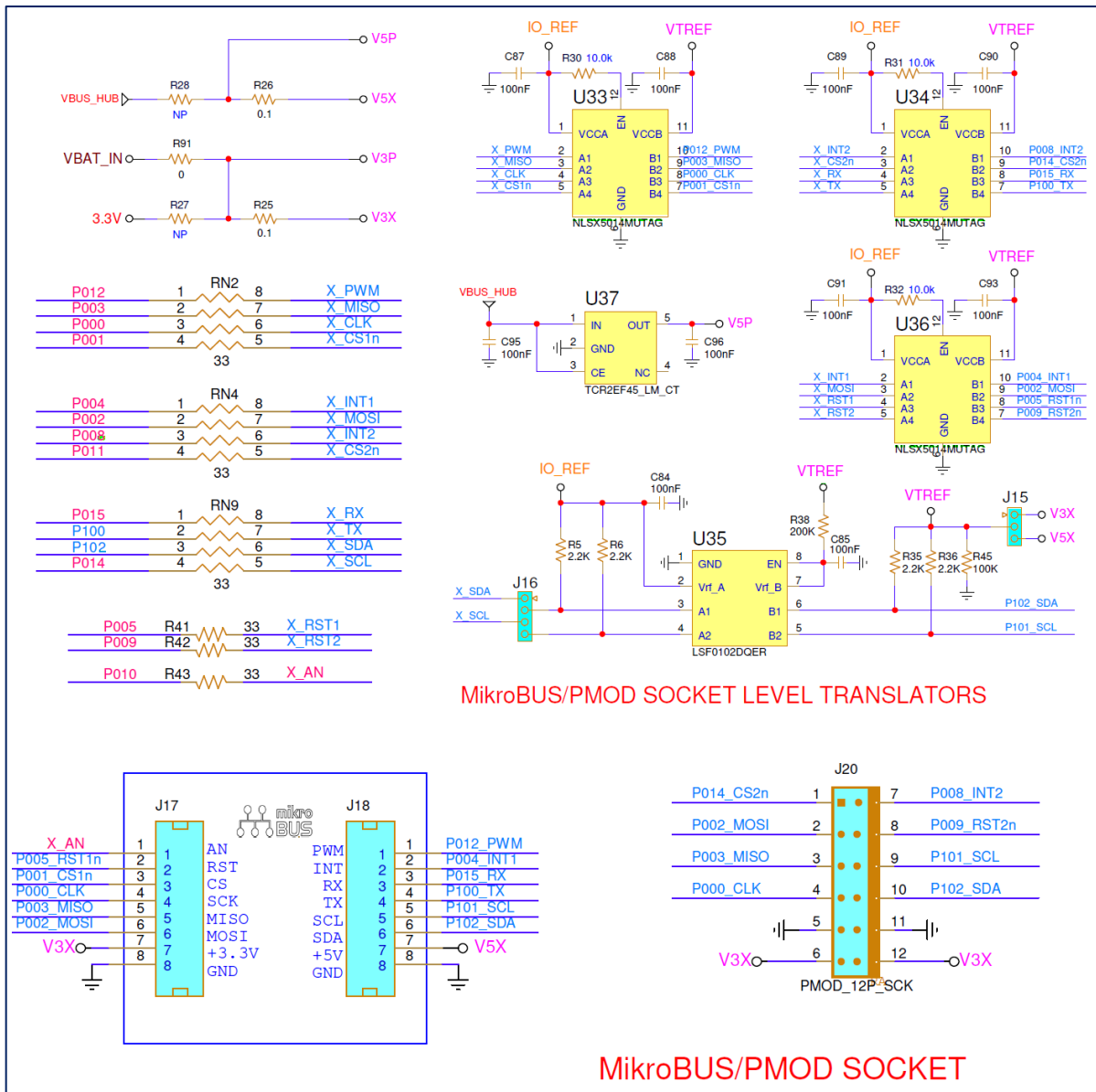

Figure 26. MikroBus and PMOD

MikroBUS is implemented with two female headers (8 position 0.100 inches, through hole, socket type), J17 and J18. PMOD is implemented with female header (right angle 10 positions 0.100 inches through hole, socket type), J20. Pins assignment is presented on [Table 9](#).

DA1459x Pro-Development Kit

Table 9. MikroBUS and PMOD signals

GPIO	GPIO multiplexing	MikroBUS		PMOD	
P0_0	QSPI_CLK	SCK	J17.4	SCK	J20.4
P0_1	QSPI_CS	CS1#	J17.3		
P0_2	QSPI_D0	MOSI	J17.6	MOSI	J20.2
P0_3	QSPI_D1	MISO	J17.5	MISO	J20.3
P0_4	QSPI_D2	INT1	J18.2		
P0_5	QSPI_D3	RST1n	J17.2		
P0_8	CMAC_SW/DIO/DIVN			INT2	J20.7
P0_9	CMAC_SWCLK			RST2#	J20.8
P0_10	PWM_2/GPADC_2/SDADC_2	AN	J17.1		
P0_11	XTAL32M/UCTS on Pro MB			CS2#	J20.1
P0_12	LPCLK/PWM_1	PWM	J18.1		
P0_14	WAKEUP_1	SCL	J18.5	SCL	J20.9
P0_15	BOOT_UART_RX	RX	J18.3		
P1_0	PGA_INp/GPADC_0/SDADC_0	TX	J18.4		
P1_2	RC32M/GPADC_3/SDADC_3	SDA	J18.6	SDA	J20.10

Limitation: QSPI bus of DA1459x is used for SPI interface for both MikroBUS and PMOD. When an external memory is applied on Pro-Daughterboard, the SPI interface is not available.

4.3.9 Power section

Power section includes the power circuitry for supplying the DA1459x Pro-Daughterboard as well as the supporting circuits on Pro-Motherboard. Figure 27 shows block diagram.

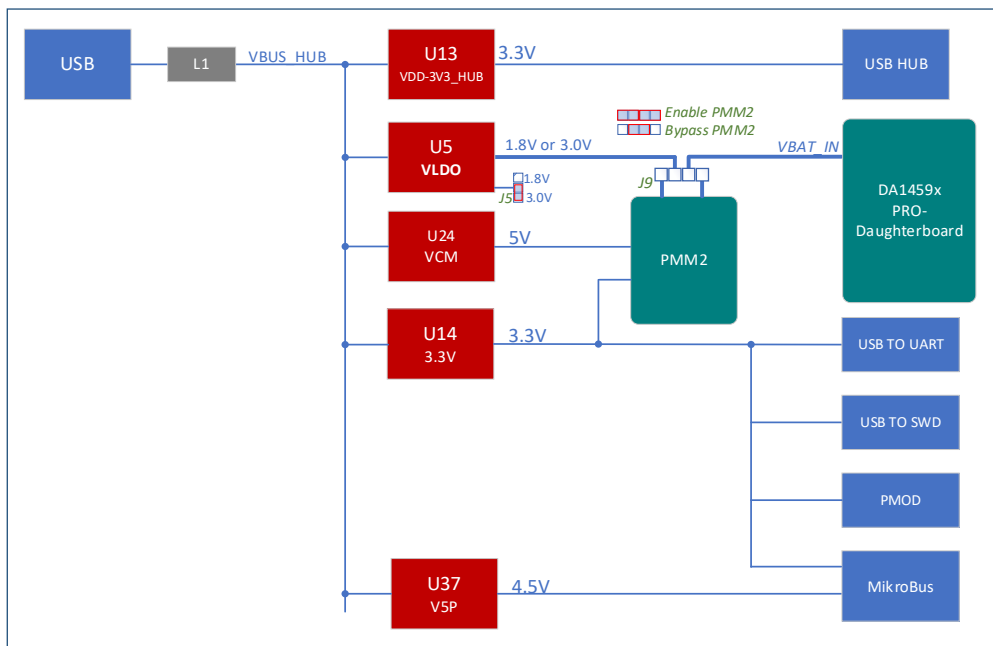

Figure 27. DA1459x Pro MB Power section block diagram block

DA1459x Pro-Development Kit

The system is supplied from the USB connector (USB1). Input current passes through a common mode chock (L1) for suppressing the incoming noise. USB Hub is supplied from U13. The rest of the Development kit is supplied from two LDOs U14 and U5. Both these components are enabled from control signal Power_Enable, which is produced from USB_HUB (U11). When a communication between USB_HUB and PC is established, Power_Enable is set high.

For the case when DA1459x Development Kit is powered by a source with no USB functionality, Power_Enable can be activated by adding a jumper on header J8 between pins3 and 4.

Pro_Motherboard circuits, including USB to UART, USB to SWD, MikroBUS and PMOD, are supplied with 3.3 V generated from LDO U14. Level translators are supplied from the same linear voltage regulator and the USB 5V voltage rail.

DA1459x Pro-Daughterboard is supplied by LDO U5, with the capability of providing either 3.0 V (default) or 1.8 V by removing jumper on header J5. The Current of VLDO can be monitored and measured from PMM2. This is accomplished by applying two jumpers on header J9, between pins 1-2 and 3-4. PMM2 can be bypassed if a jumper is applied on J9 between pins 2 and 3.

PMM2 is supplied by 5 V (=VCM) and 3.3 V. VCM is generated from a power switch which is enabled when Power_Enable is set high. 3.3 V is generated from U14.

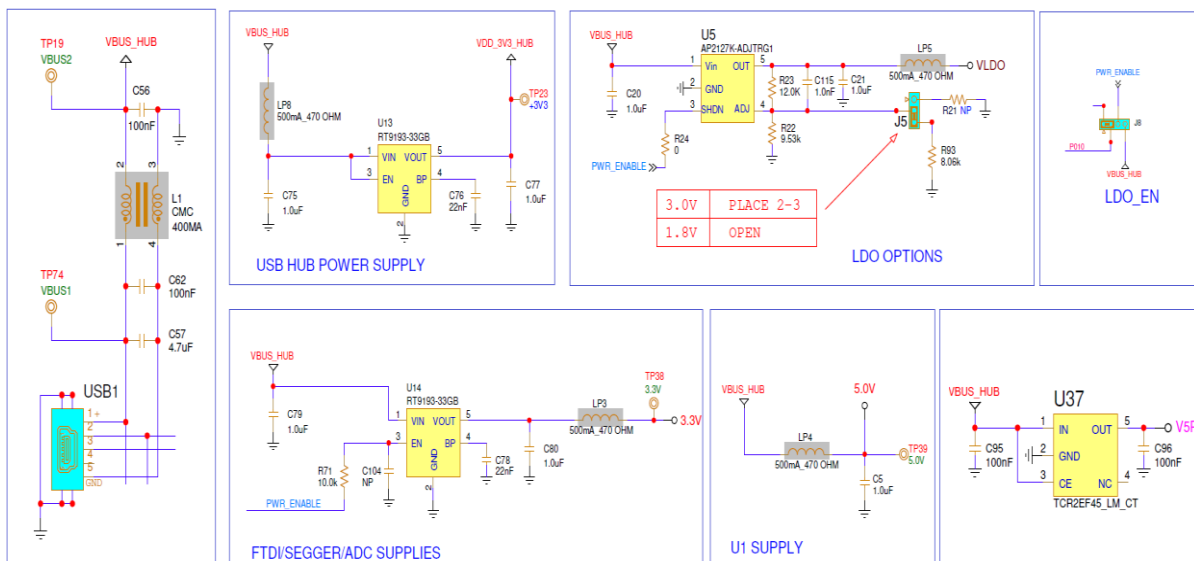

Figure 28. DA14592x Pro-Motherboard Power section

4.3.10 Measurements and software triggers

On DA1459x Development kit, user can monitor the critical current and voltages of the system. This is implemented with a power measurement circuitry which consists of the power measurement module (PMM2) and the monitoring circuit, which resides on the DA1459x Pro-Motherboard. The Power profiler of Renesas Smart Snippets Toolbox provides a good visualization of the system current drawn and various voltages. Measurements are quite accurate, but for precise measurements, use an external calibrated instrument.

PMM2 features are:

- DA1459x current measurement (1 μ A-100 mA at 128 kHz)
- Measurement of two additional system currents
- 2 x DA1459x system voltage measurement
- 9 x DA1459x system voltage monitoring
- Monitoring and measuring up to 8 Digital signals with capability to be configured as software triggers.

DA1459x Pro-Development Kit

Figure 29 shows the block diagram of PMM2. The analog frontend and ADC converter are implemented on the PMM2 module, whereas the SPI to USB bridge (FT2232H, U12) and digital signals reside on the motherboard.

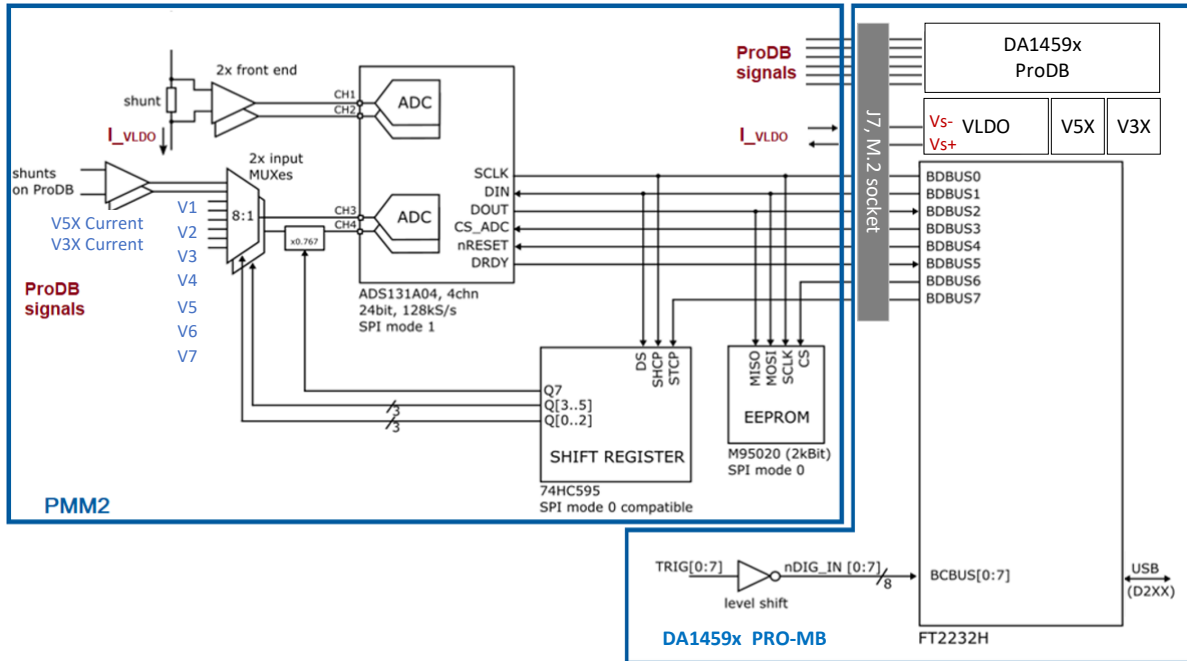

Figure 29. Power measurement module (PMM2) block diagram

An EEPROM is also provided on the module to store production data and allow autodetection from the host software.

The power measurement module (PMM2) is connected to Pro-Motherboard via J7, M.2 socket. PMM2 is supplied from 3.3 V and VCM through power switch U24.

The DA1459x does not employ shunt voltage drop compensation. The voltage drop on the PMM2 is $V_{PMM2_dropout} = 2.4 * I_{VBAT}$. Use cases for the DA1459x rarely draw more than 40-50 mA of current in which case the max voltage drop of about 100 mV due to the PMM2 should not cause problems.

DA1459x Pro-Development Kit

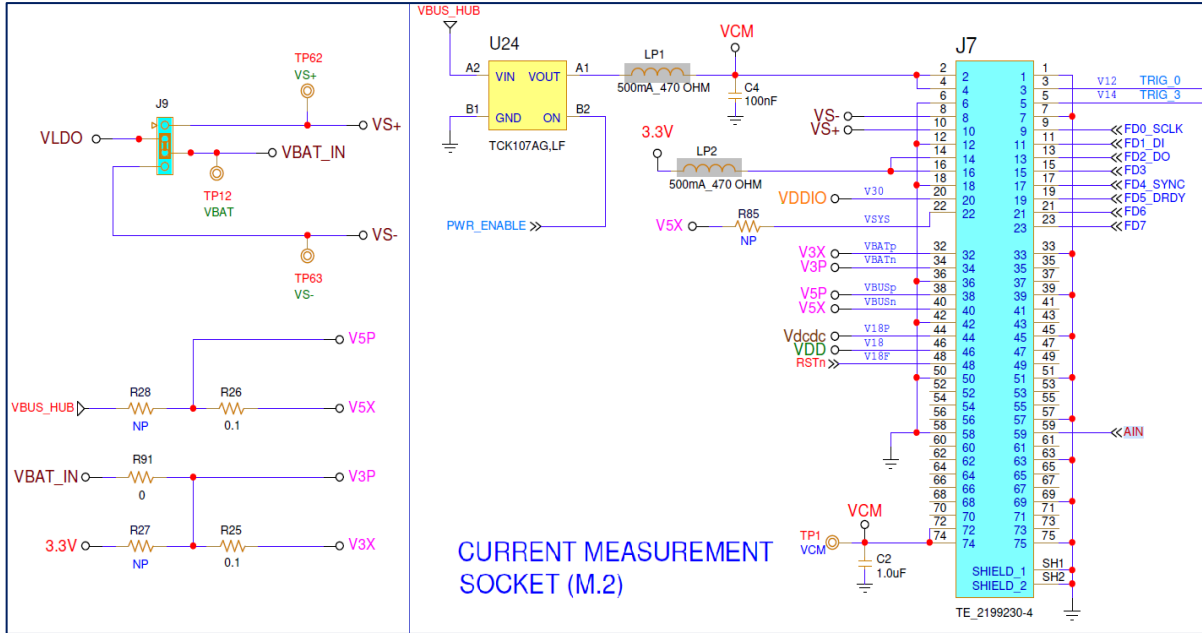

Figure 30. Current measurement socket (M2)

Table 10. Monitored power sources

Pmm2 Pins (Note1)	DA1459x Signals	Comments
V1	VDDIO	1.8 V voltage rail, applied on pin J7.20. Sourced from Pro-Daughterboard.
V2	V5X	5 V rail powering MikroBUS. It is not activated. For enabling, populate R85 =0.
V3	Vdcdc	1.1 V voltage rail, applied on pin J7.44. Sourced from Pro-Daughterboard.
V4	VDD	0.9 to 1.2 V voltage rail, applied on pin J7.46. Sourced from Pro-Daughterboard.
V5	RSTn	Reset pin applied on pin J7.48.
V6	TRIG_0	Pin P0_10 or another signal connected on J24.1. Applied on pin J7.3.
V7	TRIG_3	Pin P1_02 or another signal connected on J24.7. Applied on pin J7.5.
V8	AIN	Any signal connected on J3.24. Applied on J7.59.
VLDOp, VLDOn	Vs+, Vs-	DA1459x VBAT current measurement. Sourced from Pro-Motherboard. Current enters PMM2 from Vs+ (pin J7.10) and exits from Vs- (pin J7.8).
C1p, C1n	V3P, V3X	3.3 V voltage rail. V3X current measurement. The current drawn from PMOD.
C2p, C2n	V5P, V5X	5 V voltage rail. V5X current measurement. The current drawn from MikroBUS or PMOD.

Note 1 See PMM2 daughterboard pinout.

There are eight TRIG options defined (TRIG_0 to TRIG_7).

DA1459x Pro-Development Kit

Figure 31 shows the suitable jumper block (J7) allows you to directly select any of the available signals. Any other GPIO can be used as a trigger source by connecting a TRIG pin on J7 with a jumper wire to the desired position at breakout headers (J3..J5).

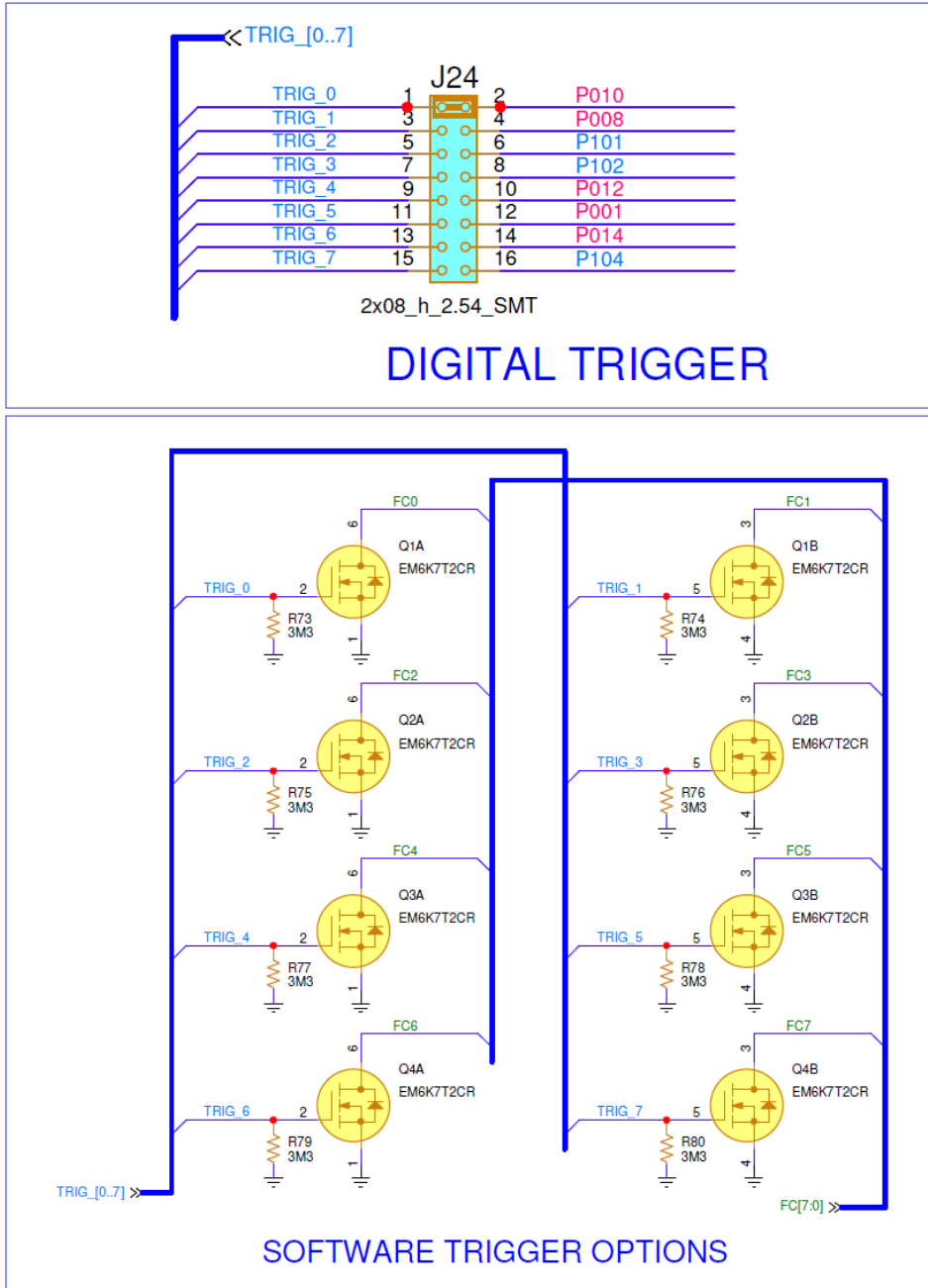

Figure 31. Selection jumper block (J24) and Buffer MOSFETS for I/O levels compatibility

The dual Mosfets Q1 to Q4 buffer the signals to provide compatibility with 1.2 to 5 V I/O levels.

Renesas Smart Snippets Toolbox is required for capturing the waveforms of DA1459x system. By using Power profiler, you can monitor simultaneously, on separated windows, the DA1459x VBAT current, two analog waveforms (voltages or currents), and up to eight digital signals, [Figure 32](#).

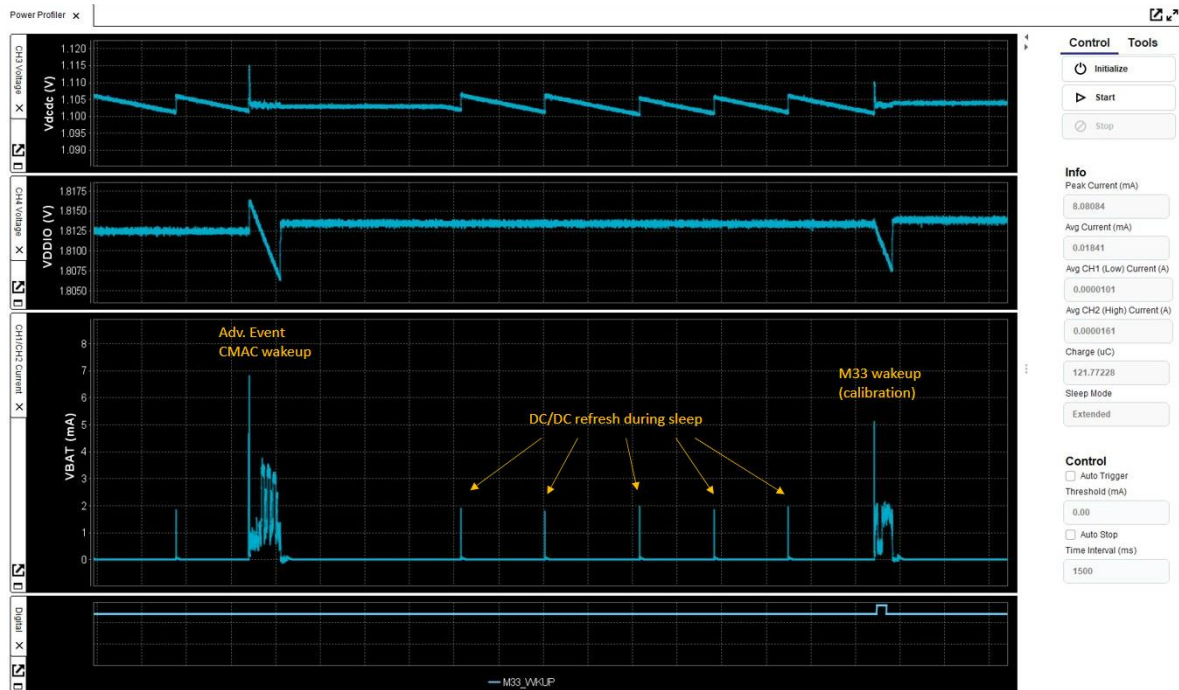

Figure 32. DA1459x waveforms, captured from Power profiler of SmartSnippet Toolbox

This functionality, coupled with the digital trigger signals allows profiling the power footprint of software operations and provides a better insight of how the system works. Digital signals can be used either as monitoring signals or as triggers to start/stop capture of data so the user can isolate specific events. The trigger functionality is implemented in SDK.

4.4 The Power measurement module 2 (PMM2), (500-29-x)

The power measurement module (PMM2) is an external add-on board that is interfaced (connected) on the Pro-Motherboard via connector J7.

The current measurement unit has the following features:

- Full scale range 640 mA at 3 V (for currents >50-100 mA dropout compensation is recommended – not implemented in the DA1459x Pro Devkit)
- Measure accurately down to 1 μ A
- Dedicated Hibernation mode to measure down to 100 nA
- Current sense resistors
 - 2.4 Ω in series to VLDO (located on PMM2)
 - 0.1 Ω in series for measuring current on C1p/C1n (located externally to PMM2)
 - 0.1 Ω in series for measuring current on C2p/C2n (located externally to PMM2)
- Analog processing blocks
- Fast quad channel 24-bit ADC with SPI interface
- FTDI chip for transferring data to the PC
- Software trigger inputs
- System voltage measurement
- External analog input 0-5 V

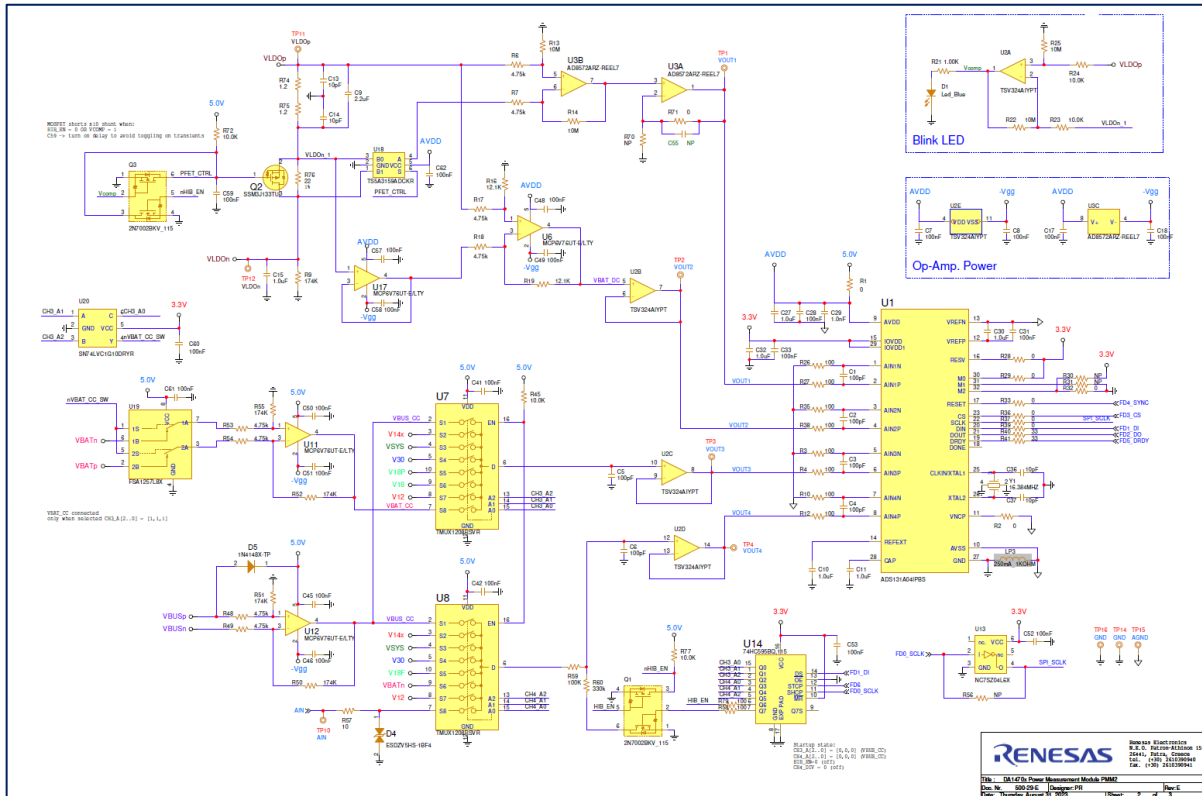

Figure 33. PMM2 current measurement circuit PMM2

The input to the circuit is the voltage across the sense resistors R74 and R75. The voltage across the sense resistors is sampled simultaneously by two differential amplifier stages and is converted by the ADC to a digital value. The low range has a conversion gain of 5053 V/A and covers from 1 μ A up to about 790 μ A. The high scale has a conversion gain of 6.114 V/A and covers up to about 600 mA depending on the VBAT voltage. Both channels are sampled simultaneously, and the host software selects the correct channel using a threshold of 750 μ A. R9 provides a constant offset which helps avoid the nonlinear region of the low scale. A blue LED serves as a visual indicator of the range. It switches on close to 750 μ A and allows you to have a quick indication of the state of the system (on when active, off when sleeping).

Multiplexers U7 and U8 select among the available system voltages and feed channels 3 and 4 of the ADC. A divider formed by R59 and R60 can be selected on CH4 to allow for 5 V input signal range (the full-scale voltage of the ADC is 4 V). Two analog front ends around U11 and U12 are provided for measuring the C1 (VBATp/n) and C2 (VBUSp/n) currents. The switch in front of U11 prevents the leakage current of the differential amplifier stage from C1 (VBATp/n) to be measured as system current.

A shift register and associated logic control the multiplexers and the rest of the functions of the module. An EEPROM memory is used to store production data and allows the host software to autodetect the module. Charge pump U6 generates a slightly negative voltage (-230 mV) to allow the output of the frontend OPAMPS to reach true zero.

DA1459x Pro-Development Kit

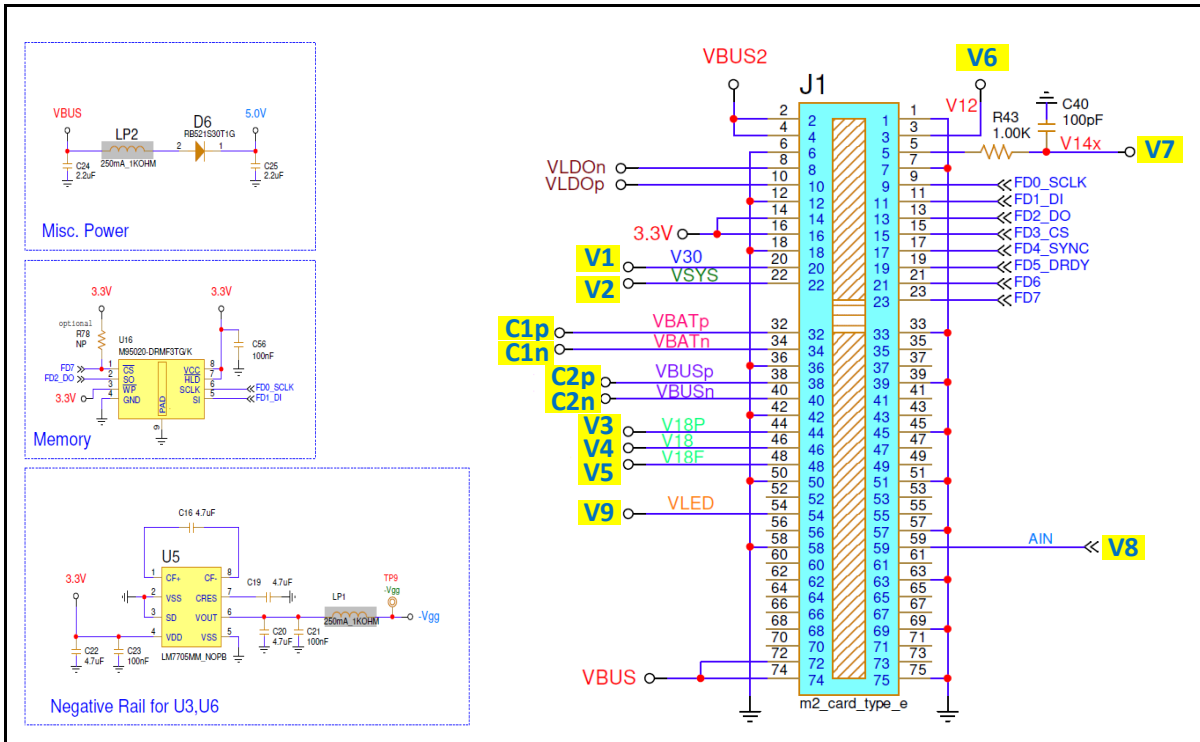

Figure 34. PMM2 on board peripherals (power supply, memory and so on)

The circuit can be set in a Low Current Measurement mode from the host (hibernation mode). This is useful to measure the current of the SoC in Hibernation (Shipping) mode, which is in the order of some hundreds of nA. The measurement range of the circuit in this mode is from 100 nA to 60 μ A. This is achieved with a significantly larger sense resistor (R76) which is shorted by Q2 in normal operation. In Hibernation mode, Q2 switches off and R76 is placed in series with R74 and R75 forming a 24.4 Ω sense resistor. The lower sampling point of the low range is moved to the terminals of this series combination with the help of analog switch U18. The high range connections remain unchanged, and it monitors the current through R74 and R75 only. To avoid excessive voltage drop due to the large sense resistor in case the system wakes up and draws large currents, the LED indicator output also overrides the control of Q2 when the measured current exceeds ~600-700 μ A. This ensures that the system can wake up normally and its operation is not affected by the Hibernation mode. The Hibernation mode is intended for measuring low level and mostly stable currents.

The offset of the circuit can be calibrated in the Smart Snippets Toolbox software. The procedure necessitates disconnecting the daughterboard either physically or by sliding the daughterboard power selection switch to the right.

Sampling rate is by default 128 kS/s but can be further reduced to 84 kS/s when using slower machines or lower speed USB ports. All analog and digital signals are sampled simultaneously.

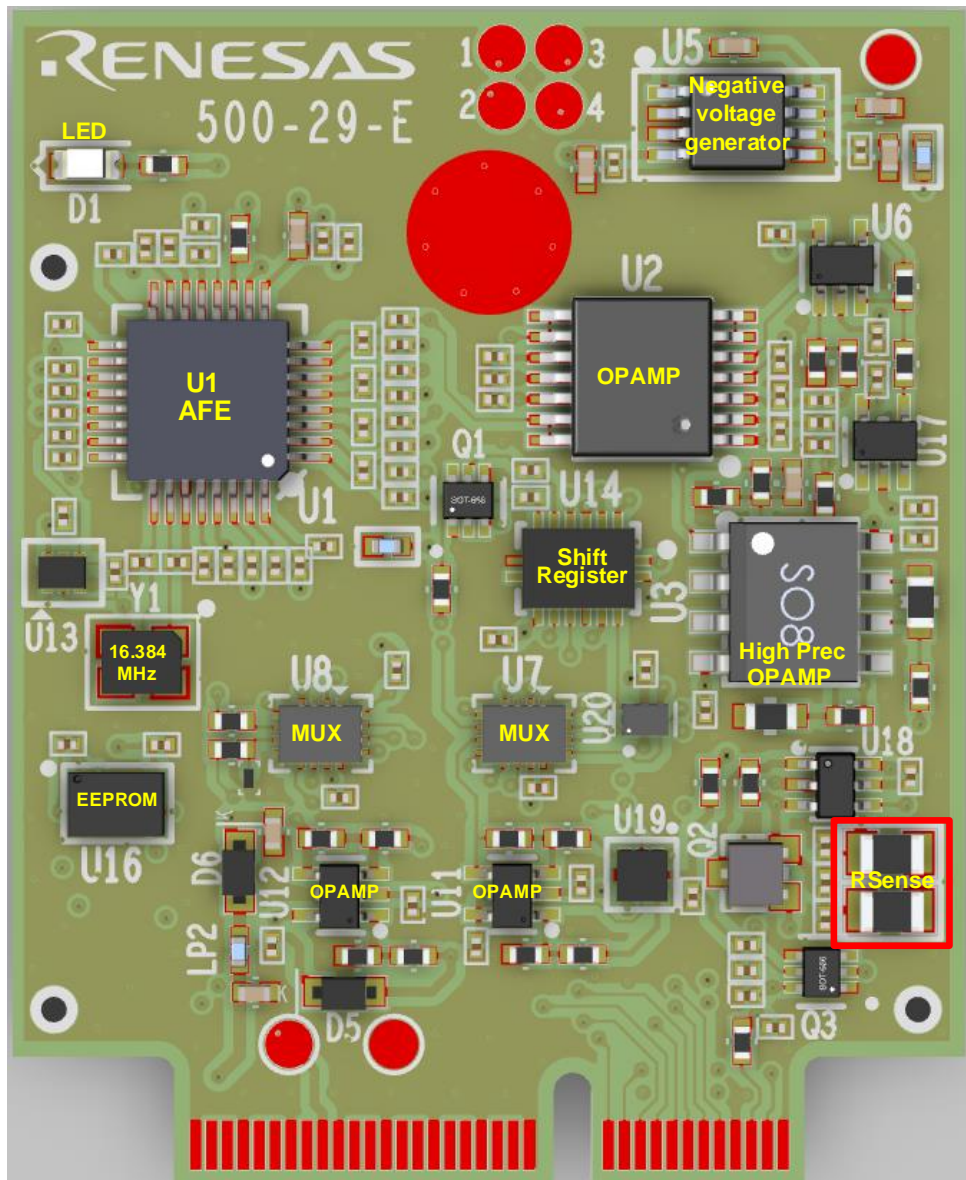

Figure 35. Current measurement unit PCBA (TOP)

4.4.1 Accuracy of Current Measurement for VBAT System (VLDO)

The total measuring range of the current measurement circuit of the power measurement module two is 100 nA to 500 mA for VLDO= 3 V, implemented into two scales. The current measurement range is covered by two operating modes, the default (1 μ A to 500 mA) and the Hibernation mode (100 nA to 60 μ A). Switching from Default to Hibernation mode is done manually over Smart Snippets Toolbox (a version supporting this mode must be used).

The circuit accuracy is measured by applying a constant current, monitoring the same current with an external instrument and the ADC of the PMM2 module, then comparing the two. In general, the inaccuracy presented in the current measurement circuit is less than 5 % (practically less than 2 %) in most of the current range, (Table 11). Note that the values presented in Figure 36 are averages of multiple points.

DA1459x Pro-Development Kit

Table 11. Accuracy of the current measurement circuit

Channel	Range	Error (%)	Comment
CH1/CH2: VBAT current hibern.	100 nA-60 μ A	$\pm 15\%$ at 100 nA, $< \pm 2\%$ at 1 μ A-60 μ A	Mode automatically overridden in hardware if current $> \sim 750 \mu$ A
CH1/CH2: VBAT current active	1 μ A-640 mA	$\pm 10\%$ at 1 μ A, $< \pm 2\%$ at 100 μ A-640 mA	2 ranges [1 μ A-750 μ A/750 μ A-640 mA]
CH3, CH4 current: C1p/n, C2p/n	1 mA-1 A	$\pm 5\%$	Range and accuracy depend on external R_{sense} . Values shown with 0.1 Ω /1% shunt
CH3 voltage	0-4 V	$\pm 2\%$	
CH4 voltages	0-4 V/0-5 V	$\pm 2\%$	0-5 V range available with 0.776x divider enabled

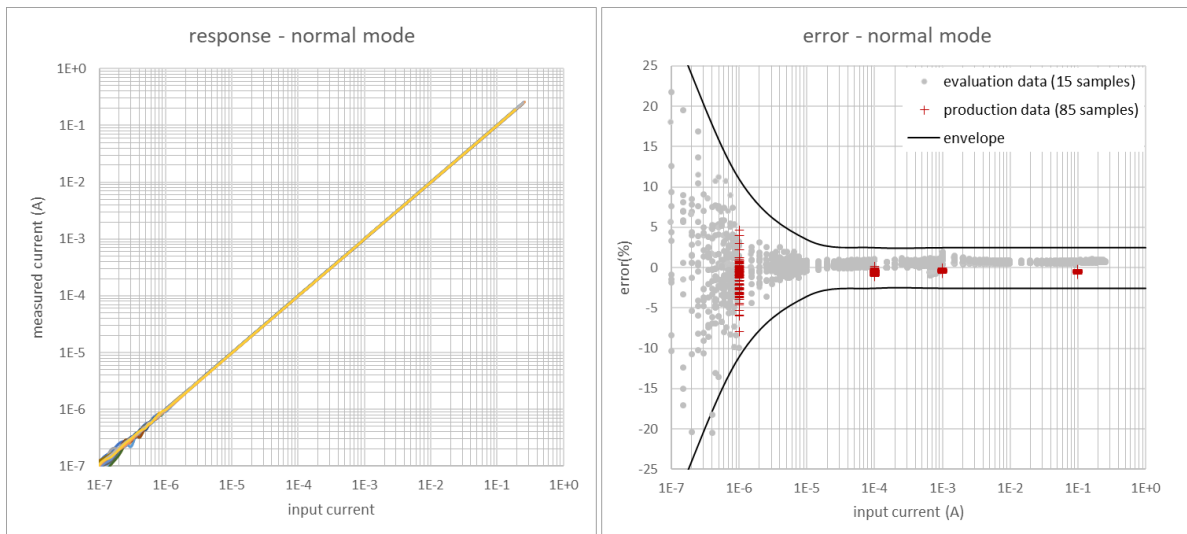

Figure 36. Normal mode (1 μ A to 640 mA at 3.3 V) data after offset calibration

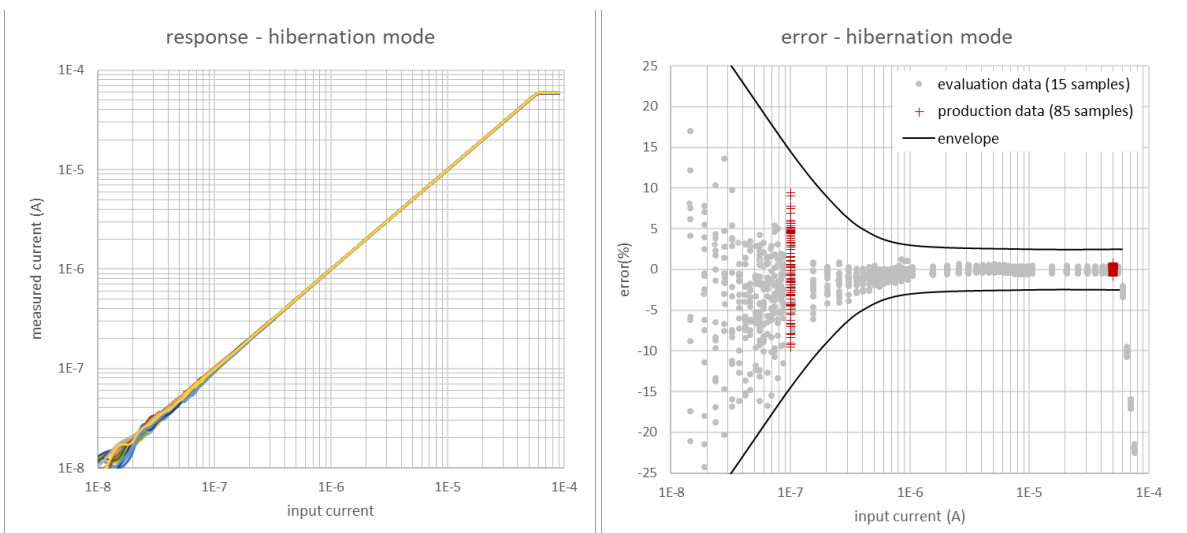

Figure 37. Hibernation mode (100 nA to 60 μ A at 3.3 V) data after offset calibration

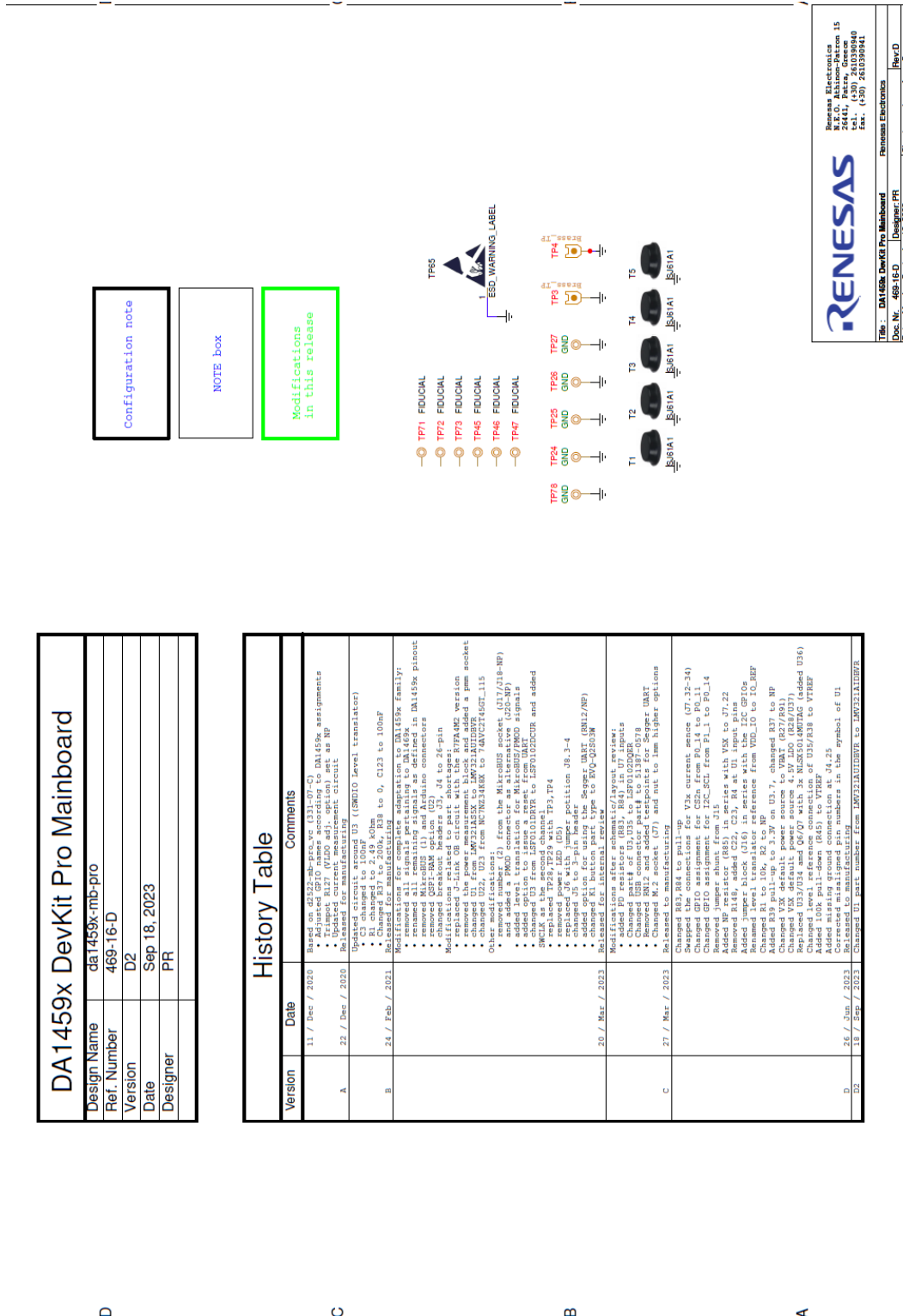

Figure 38. DA1459x Pro-Motherboard schematic, modification history page

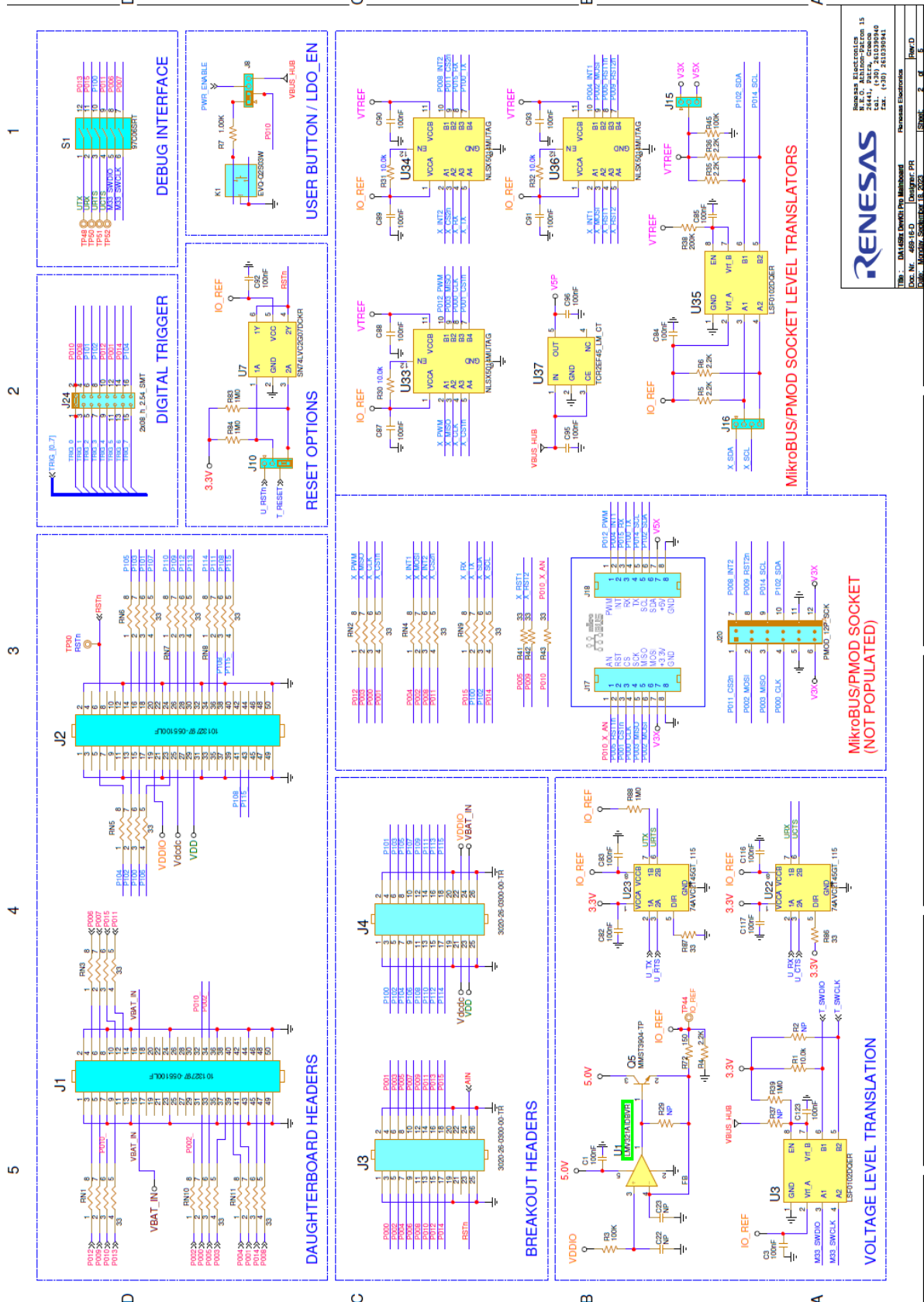
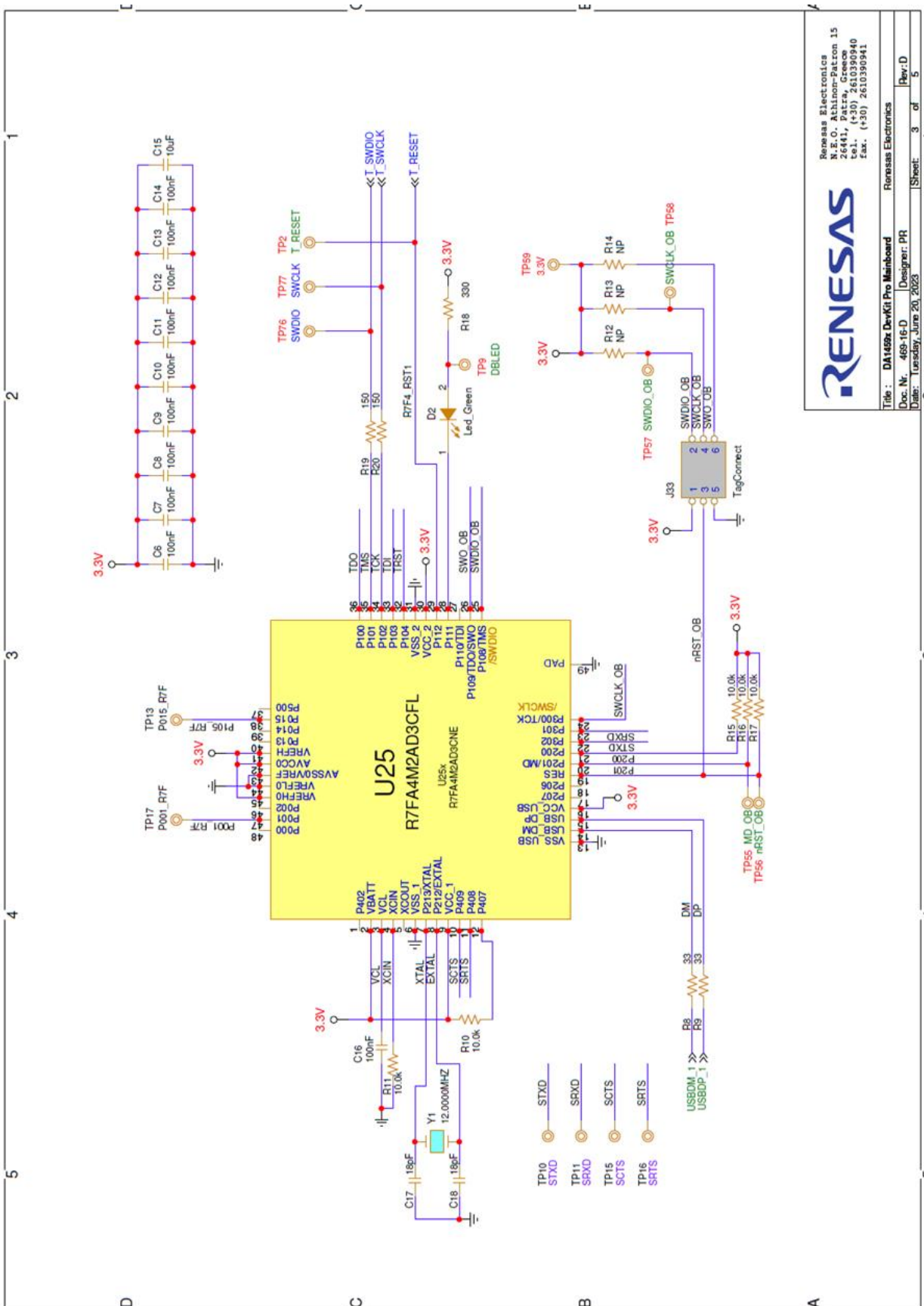

Figure 39. DA1459x Pro-Motherboard schematic, connectivity, and level translators



Renesas Electronics
 No. 1, Nishimuro 15
 26441, Patate, Gero-cho
 Tel. (+30) 2610390940
 Fax. (+30) 2610390941

Title : DA1459x DevKit Pro Mainboard
 Doc. Nr. 468-16-D Designer: PR
 Date: Tuesday, June 20, 2023
 Sheet: 3 of 5
 Rev: D

Figure 40. DA1459x Pro-Motherboard schematic, SWD implementation

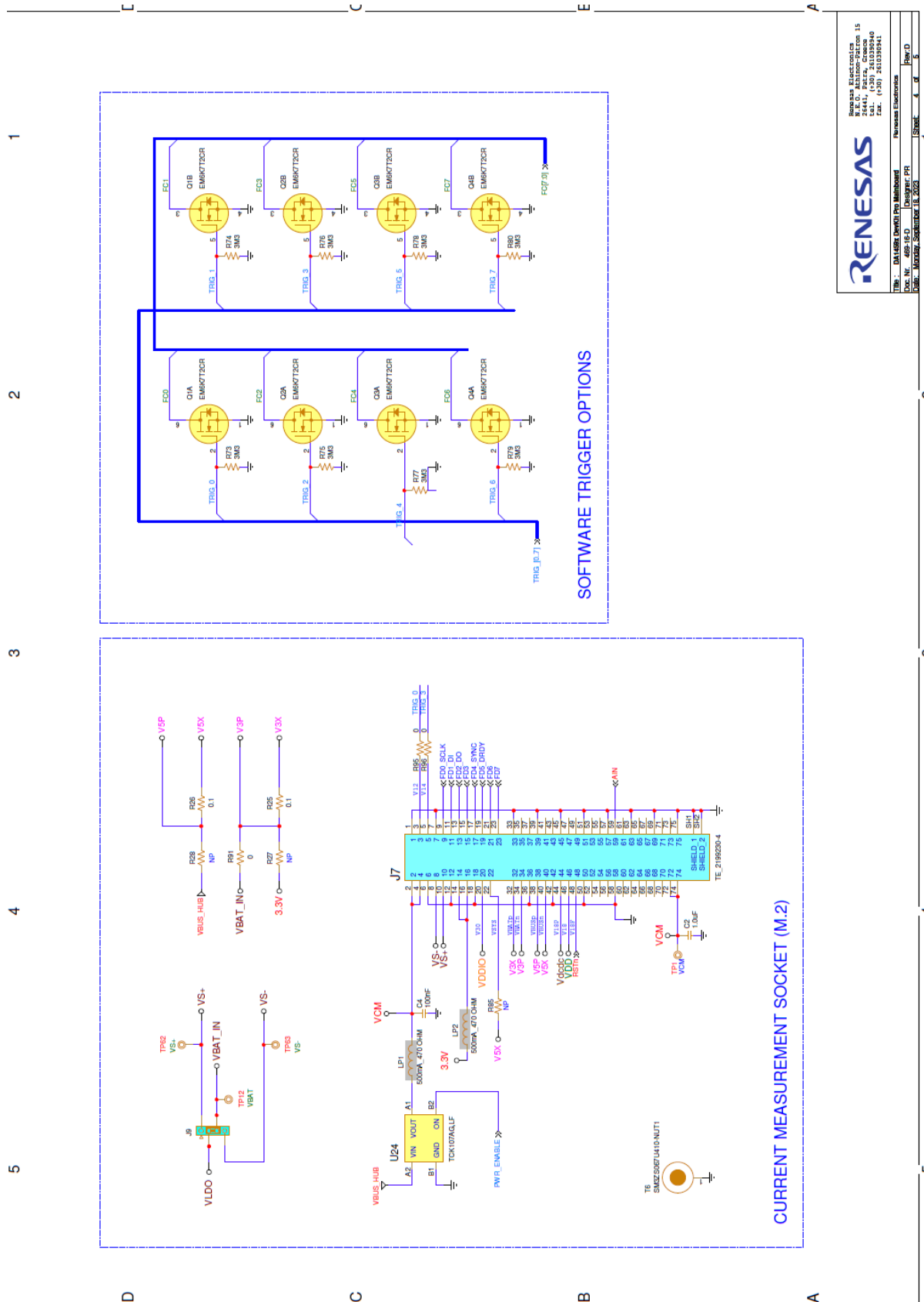

Renesas Electronics Corp.
 2-4-41, Daikoku, Chokyo
 City, Aichi 466-8501, Japan
 TEL: (81) 53 678 2200
 FAX: (81) 53 678 2201

Title: DA1459x Pro-Motherboard
 Doc. No.: UM-B-167
 Rev. 4.01

Part Name: DA1459x Pro-Motherboard
 Part No.: 685-014-01
 Rev. 4.01

Figure 41. DA1459x Pro-Motherboard schematic, PMM2 interface and software trigger buffers

DA1459x Pro-Development Kit

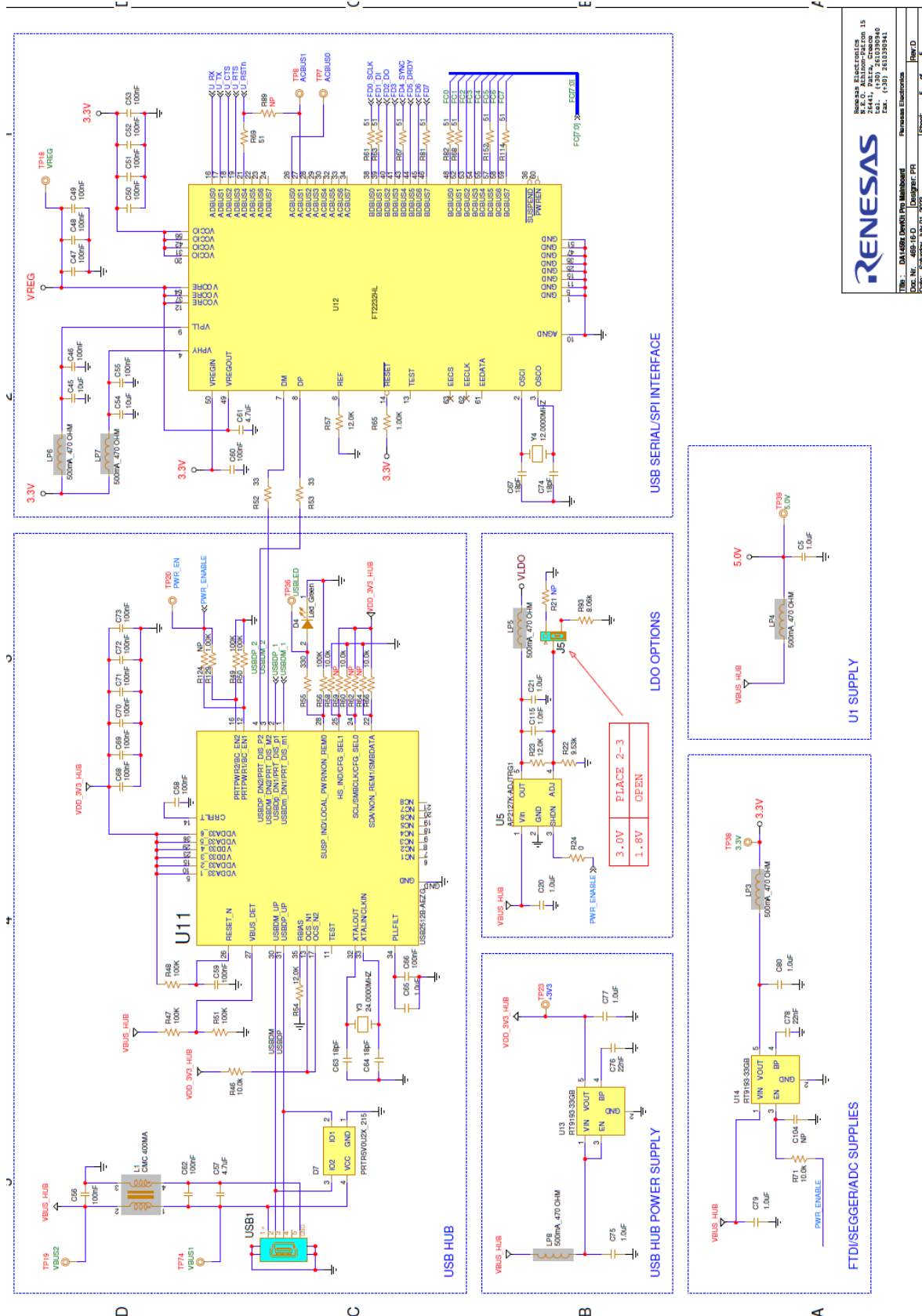

Figure 42. DA1459x Pro-Motherboard schematic, USB Hub, UART to USB and power supply

Renesas Electronics Corporation
 2-4-41, Sakae, Chuo-ku
 Nagoya, Aichi 466-8601, Japan
 Tel.: (81) 52 734 2100
 Fax: (81) 52 734 2101
 E-mail: renesas@renesas.com

Doc. No. 466-86-01
 Rev. 1.0
 Date: 2023.07.01

Part No. DA1459x Pro-Motherboard
 Design: P1
 Revision: 1.0
 Sheet: 5 of 5

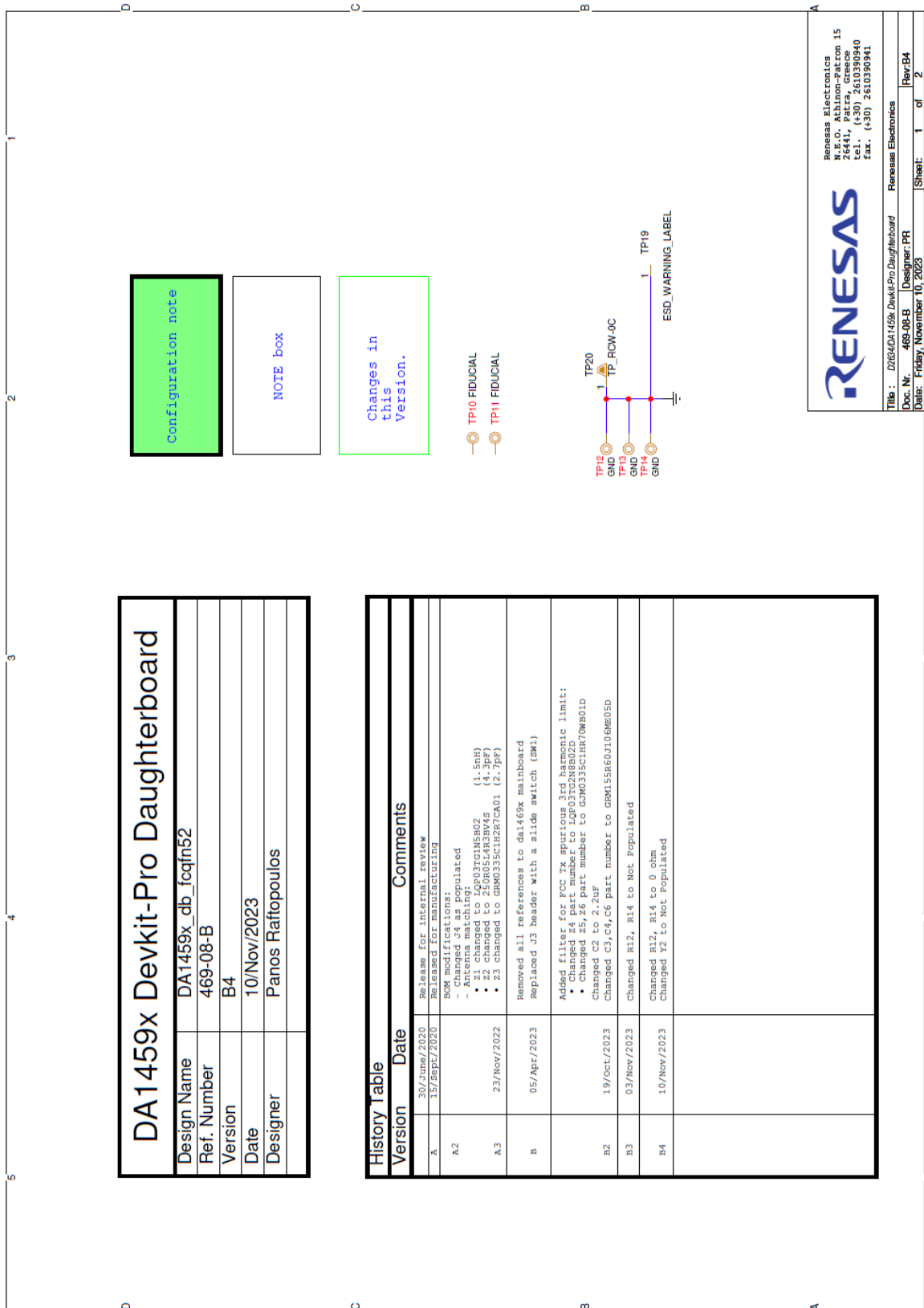
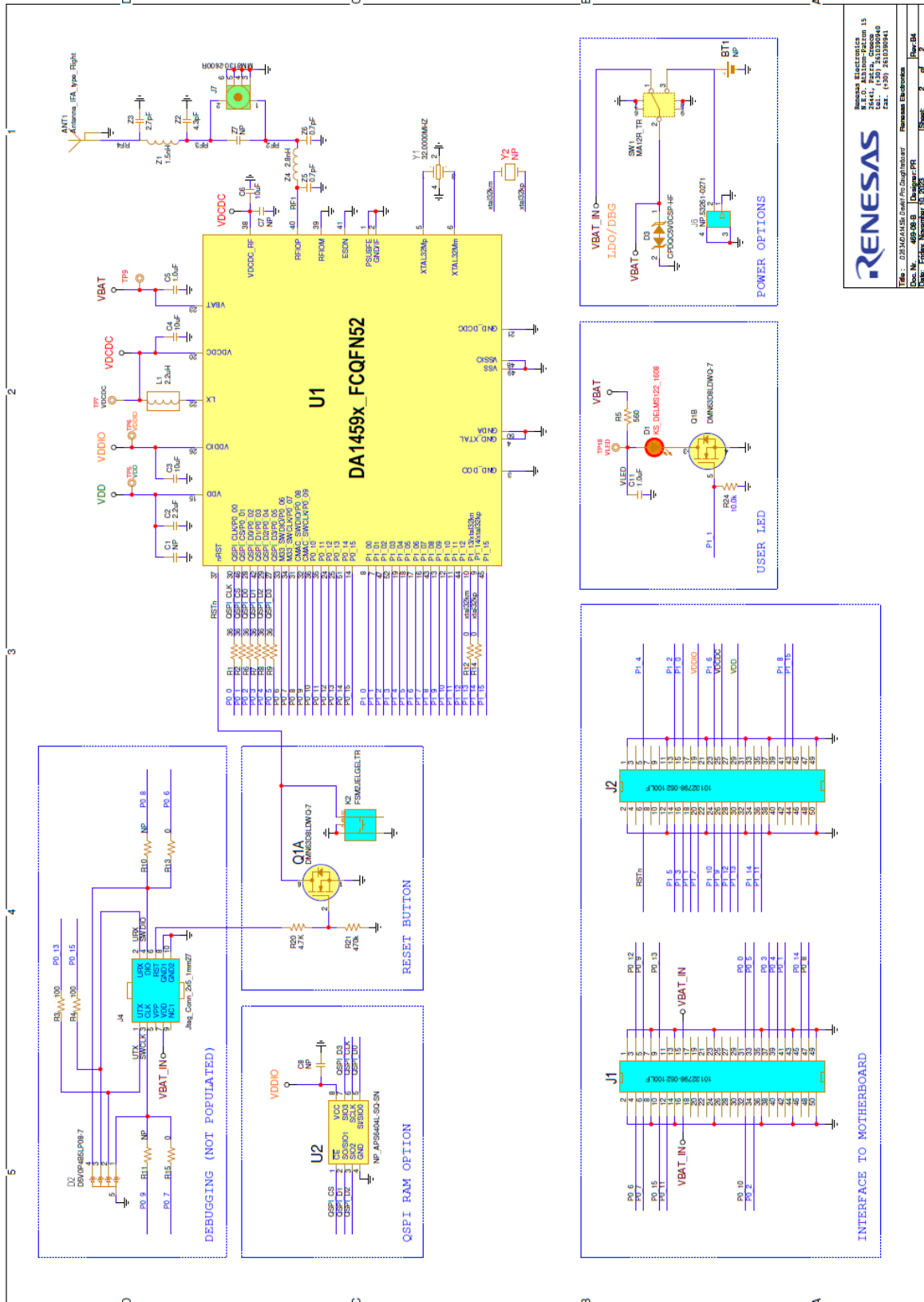

Figure 43. DA1459x_db_fcqfn52, modification history page



RENESAS

RENESAS ELECTRONICS
2-1-1, Atsuta-ku, Nagoya 466-8601, Japan
Tel.: (81) 52 653 5000
Fax: (81) 52 653 5044

Doc. No.: UM-B-167 Rev. 1.0
Date: 2024.03.15
Product: DA1459x Pro-Development Kit

Page 24 of 24

Figure 44. DA1459x_db_fcqfn52, the circuit

DA1459x Pro-Development Kit

A.3 DA1459x-db-wlcsp39 schematic

DA1459x Devkit-Pro Daughterboard	
Design Name	d2634-db-wlcsp39
Ref. Number	469-07-C
Version	C3
Date	09/Oct/2023
Designer	Panos Raftopoulos

History Table	Version	Date	Comments
A0.9		27/Feb/2020	Release for internal review
		05/Mar/2020	Added TVS diodes (D3 -- CPGQCV0CSP-RF) to VBAT Changed J220, C5, C6 to Renesas matching Changed Z2 to 1.0pF (antenna matching) Changed Z3 to 0.5pF (antenna matching) Changed net name on R16*2/J1*20 from P0_16 to C_TIRIG(PL_2) Released B.O.M. to assembly house Added alternative package option (H1609) for H1
A1.0		09/Mar/2020	Applied modifications to support extended temp. range
		16/Mar/2020	<ul style="list-style-type: none"> • Changed K2 part number to ZSM415A3R • Changed J1 to K1 and added Z7 (11pF) 5% bypass • Changed J2 to K2 and added Z7 (11pF) 5% bypass • Changed part number of J1 to M70103A-2MMF-B280A • Changed C14, C6 to 2801XCE0104M050 • Changed C14, C6 to 2801XCE0104M050 Released for manufacturing
A1.1		03/Apr/2020	ROM modification:
		30/Jun/2020	Changed J7 as populated, Z7 as NP (engineering builds only)
A1.3		22/Oct/2020	ROM modification: Changed J7 as populated. Added Note for J7
A1.4		16/Nov/2020	RF Matching changes: <ol style="list-style-type: none"> 1. Z1 changed to IQP03TG2N8502 1.5nH 2. Z2 changed to 250R0554R3W45 4.3pF 3. Z3 changed to GM0335C1H2R7CA01 2.7pF
			Removed all references to dai469x mainboard
			Replaced J3 header with a slide switch (SW1)
			Removed xtal32k option (Y2/NF)
			Changed the footprint of J4 header (NP) to SMT type
			Modified RF traces on the PCB for impedance matching
			Added filter for FCC TX spurious 3rd harmonic limit: <ul style="list-style-type: none"> • Changed Z4 part number to IQP03TG2N8502D • Changed Z5, Z6 part number to GM0335C1H70WB01D
			Changed C5 to 2.2uF
			Changed C5, C6 part number to GPM155R601104M050

Configuration note

NOTE box

Changed in this Version.

	Renesas Electronics 1150, Atkinson-Patron 15 Street, Irvine, CA 92614 USA Tel. (+30) 2610390940 Fax. (+30) 2610390941
Title : D2634/DA1459x Devkit-Pro Daughterboard	
Doc. No. 469-07-C	Designer: PR
Date: Thursday, October 19, 2023	Sheet: 1 of 2

Figure 45. DA1459x-db-wlcsp39, modification history page

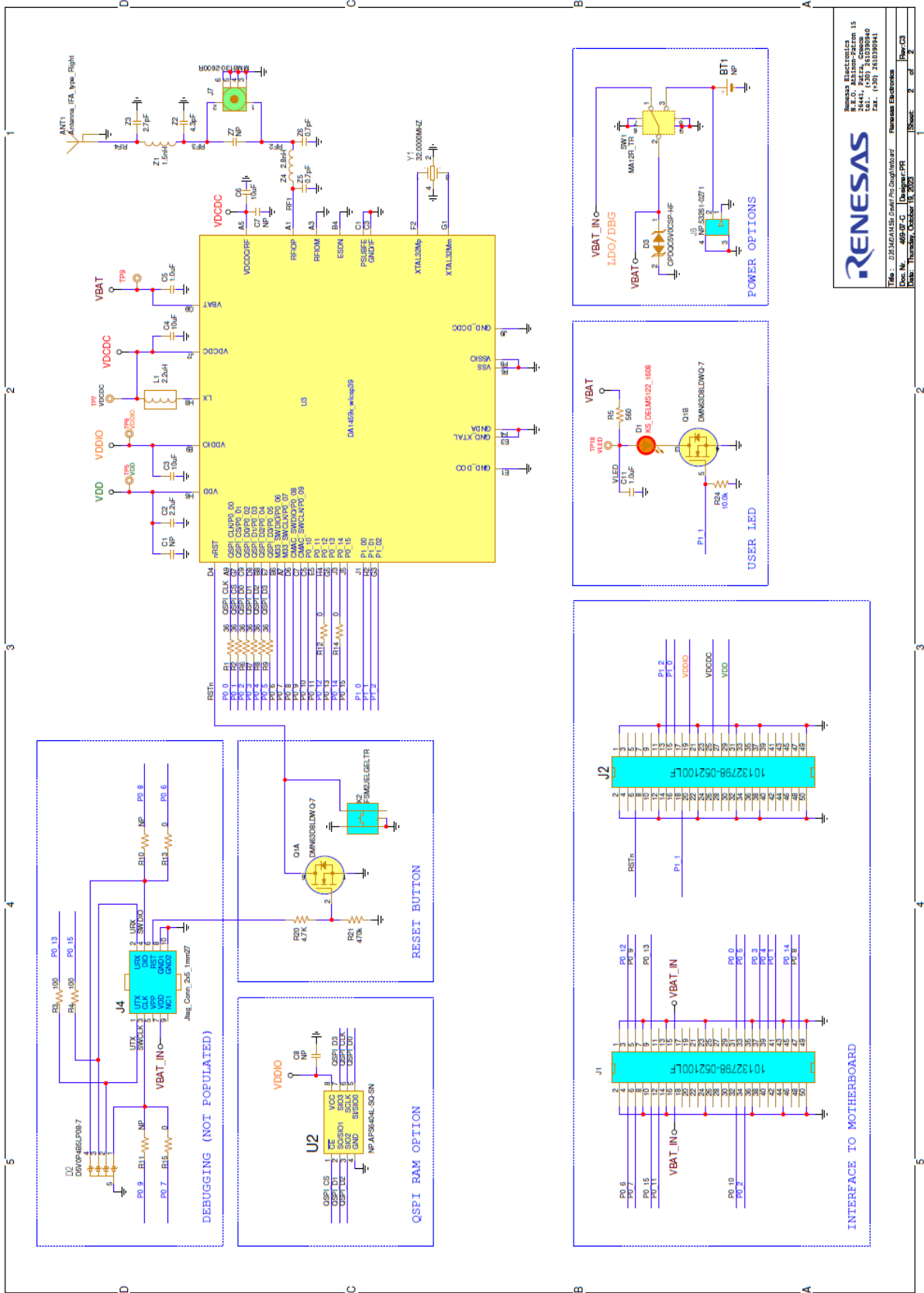

RENESAS

DA1459x Pro-Development Kit

Doc. No. 66207-C | Design-PR

Rev. 2 of 2

Issue: 2 of 2

Page: 3 of 3

Figure 46. DA1459x-db-wlcsp39, the circuit

Revision History

Revision	Date	Description
1.1	Mar 1, 2024	Updated schematics to latest revisions. Editorial.
1.0	Nov 30, 2023	Initial version.

DA1459x Pro-Development Kit

Status Definitions

Status	Definition
DRAFT	The content of this document is under review and subject to formal approval, which may result in modifications or additions.
APPROVED or unmarked	The content of this document has been approved for publication.

RoHS Compliance

Renesas' suppliers certify that its products are in compliance with the requirements of Directive 2011/65/EU of the European Parliament on the restriction of the use of certain hazardous substances in electrical and electronic equipment. RoHS certificates from our suppliers are available on request.

IMPORTANT NOTICE AND DISCLAIMER

RENESAS ELECTRONICS CORPORATION AND ITS SUBSIDIARIES (“RENESAS”) PROVIDES TECHNICAL SPECIFICATIONS AND RELIABILITY DATA (INCLUDING DATASHEETS), DESIGN RESOURCES (INCLUDING REFERENCE DESIGNS), APPLICATION OR OTHER DESIGN ADVICE, WEB TOOLS, SAFETY INFORMATION, AND OTHER RESOURCES “AS IS” AND WITH ALL FAULTS, AND DISCLAIMS ALL WARRANTIES, EXPRESS OR IMPLIED, INCLUDING, WITHOUT LIMITATION, ANY IMPLIED WARRANTIES OF MERCHANTABILITY, FITNESS FOR A PARTICULAR PURPOSE, OR NON-INFRINGEMENT OF THIRD-PARTY INTELLECTUAL PROPERTY RIGHTS.

These resources are intended for developers who are designing with Renesas products. You are solely responsible for (1) selecting the appropriate products for your application, (2) designing, validating, and testing your application, and (3) ensuring your application meets applicable standards, and any other safety, security, or other requirements. These resources are subject to change without notice. Renesas grants you permission to use these resources only to develop an application that uses Renesas products. Other reproduction or use of these resources is strictly prohibited. No license is granted to any other Renesas intellectual property or to any third-party intellectual property. Renesas disclaims responsibility for, and you will fully indemnify Renesas and its representatives against, any claims, damages, costs, losses, or liabilities arising from your use of these resources. Renesas' products are provided only subject to Renesas' Terms and Conditions of Sale or other applicable terms agreed to in writing. No use of any Renesas resources expands or otherwise alters any applicable warranties or warranty disclaimers for these products.

(Disclaimer Rev.1.01 Jan 2024)

Corporate Headquarters

TOYOSU FORESIA, 3-2-24 Toyosu,
Koto-ku, Tokyo 135-0061, Japan
www.renesas.com

Trademarks

Renesas and the Renesas logo are trademarks of Renesas Electronics Corporation. All trademarks and registered trademarks are the property of their respective owners.

Contact Information

For further information on a product, technology, the most up-to-date version of a document, or your nearest sales office, please visit www.renesas.com/contact-us/.