

User Manual

GreenPAK Pro

Development Platform

UM-GP-006

Abstract

This user manual provides basic guidelines for the developers to get familiar with the GreenPAK Pro Development Platform. It gives an overview of the hardware, as well as the functional description of this platform, and shows the example projects using SLG46880.

Contents

Abstract	1
Contents	2
Figures	3
Tables	3
1 Terms and Definitions	4
2 Introduction	5
2.1 GreenPAK Designer	5
2.2 Support	5
3 Getting Started	6
3.1 Introduction	6
3.2 Install Software	6
3.3 Uninstall Software	6
4 Hardware	7
4.1 Overview	7
4.2 Functional Description	8
4.2.1 Power Supply	8
4.2.2 USB 3.0 Communication	8
4.2.3 Socket Connector	9
4.2.4 Expansion Connector	9
4.2.5 Generators	10
4.2.6 Pins Connectivity	12
4.2.7 Preparing GreenPAK Pro Development Board	15
4.2.8 Chip PIN versus Development Board Test Point	16
4.2.9 Using 20 Pins Socket Adapter with 32 Pins Socket Connector	17
5 Example Projects using SLG46880	19
5.1 Project: Counter with Clock Enable	19
6 Conclusion	30
Appendix A Electrical Specification	31
Revision History	32

Figures

Figure 1: GreenPAK Pro Development Board, Top View	8
Figure 2: USB Interface	9
Figure 3: GreenPAK Socket Connector Pinout	9
Figure 4: GreenPAK Expansion Connector Pinout	9
Figure 5: Expansion Connector Control in GreenPAK Designer	10
Figure 6: Choosing Generators	11
Figure 7: Managing Buttons	11
Figure 8: Global Linkage Settings	11
Figure 9: Schematic Connection of the V _{DD} Pin	14
Figure 10: Schematic Connection of the Data Pin	15
Figure 11: GreenPAK Pro Development Board Ready to Work	16
Figure 12: PINs and TPs Location	16
Figure 13: Some PINs and TPs Accordance (for SLG46880V)	17
Figure 14: 20 Pins Socket Adapter Connected into 32 Pins Socket Connector	18
Figure 15: GreenPAK Designer Components	19
Figure 16: GreenPAK Components List	20
Figure 17: Pin1 Mode	21
Figure 18: Look Up Table Properties Configured as an AND Gate	22
Figure 19: Look Up Table Properties Configured as a NOR Gate	23
Figure 20: Counter Properties	24
Figure 21: Ready Project in GreenPAK Designer	25
Figure 22: Additional Emulation Toolbar in Emulation Mode	25
Figure 23: Generator Settings Window	26
Figure 24: “Add” Menu List	26
Figure 25: “EXT IN/OUT” Pin Output	26
Figure 26: Signal Labels and Control Panels	27
Figure 27: Logic Generator Properties	27
Figure 28: Emulator Controls Window	28
Figure 29: Waveform, Triggered on Button Pressed	28
Figure 30: Waveform, no Triggered on Button Released	29
Figure 31: Waveform of the Pulse Width of the Logic Generator and Count End Signal	29

Tables

Table 1: Data Pin Connections Schematics	12
Table 2: GreenPAK Pin Configuration	21

1 Terms and Definitions

ADC	Analog-to-Digital Converter
DAC	Digital-to-Analog Converter
ESD	Electrostatic Discharge
GND	Ground
GP	General Purpose
IC	Integrated Circuit
IDE	Integrated Development Environment
LED	Light Emitting Diode
LUT	Look Up Table
MCU	Microcontroller Unit
OTP	One-Time Programable
OV	Over-Voltage
NC	Not Connected
RAM	Random-Access Memory
SoC	System on a Chip
TP	Test Point
USB	Universal Serial Bus
UV	Under-Voltage
V _{DD}	Power Supply
V _{PP}	Programming Voltage

GreenPAK Pro Development Platform

2 Introduction

Thank you for choosing Renesas Electronics Corporation products. The GreenPAK Pro Development Platform allows you to develop your custom design using GreenPAK mixed signal ICs. You can design your own projects starting from a blank project, or by altering the sample projects provided at www.renesas.com.

2.1 GreenPAK Designer

GreenPAK Designer is an easy-to-use full-featured integrated development environment (IDE) that allows you to specify exactly how you want the device to be configured. This provides you direct access to all GreenPAK device features and complete control over the routing and configuration of a PAK project with just one tool.

With GreenPAK Designer, you can:

- Design the configuration which corresponds to your project needs;
- Verify the project using software interface to GreenPAK Pro Development Platform hardware;
- With simple-to-use and intuitive software and hardware tools you can reduce your project development time and get to market faster.

To start working with GreenPAK Designer please take the following steps:

- Download and install GreenPAK Designer software;
- Configure modules that you will need for your project;
- Interconnect and configure modules;
- Specify the pins out;
- Test your design with the GreenPAK Pro Development Platform.

2.2 Support

Free support for GreenPAK Pro Development Platform is available online at www.renesas.com.

At **facebook** : www.facebook.com/RenesasElectronics.

GreenPAK Designer will automatically notify you when a new version of software is available. For manual updates please go to <https://www.renesas.com/software-tool/go-configure-software-hub>.

These resources are also available under the **Help** menu of GreenPAK Designer.

3 Getting Started

3.1 Introduction

This chapter describes how to install and configure the GreenPAK Pro Development Platform. Section 4 provides the details of hardware operation. Section 5 provides an instructions on how to create a simple project.

3.2 Install Software

GreenPAK Designer software is available free of charge from the Renesas Electronics Corporation website at <https://www.renesas.com/software-tool/go-configure-software-hub> page.

Drivers required for the operation of the board will be installed as part of the software installation.

3.3 Uninstall Software

The software can be uninstalled in the way typical for your operating system. Please refer to your operating system support documentation if you need the specific instructions or visit Section 2.2 of this document for additional support from Renesas Electronics Corporation.

GreenPAK Pro Development Platform

4 Hardware

4.1 Overview

The GreenPAK Pro Development Platform is a high-performance development platform. The Super Speed USB 3.0 interface on the Development Board supports high speed data transfer and configuration flexibility. GreenPAK Pro Development Board provides a high data rate pattern generator with 30 digital channels and time resolution down to 40 ns point time per channel. For chip power usage analysis GreenPAK Pro Development Board includes a 2 channel power monitor for measuring voltage and current consumption parameters. These power monitors have two current measuring ranges: high current measurement that supports up to 60 mA and low current measurement that supports up to 1 mA. The current resolution in low current mode is equal to 400 nA. The external power rails include voltage protection to 15 V and UV/OV level control in chip emulation mode. The power rails voltage ranges are from 0.5 V to 5.5 V.

The analog portion of this Development Board has a 32-channel arbitrary waveform generator with 8 μ s point time conversion and low latency data reconfiguration. Each test point channel has connection to a 400 kSps ADC for voltage measurement. Two channels are used for voltage control of the power rails. For support of high accuracy measurement this Development Board includes an SoC with a 100 kSps 16-bit ADC. This SoC is connected to each test point pin and can provide chip programming. SoC functionality includes OV/UV sense and switch on/off. For GreenPAK memory programming high voltage power rail up to 9 V controlled by SoC MCU is used also. This program rail is named V_{PP} and is connected to test point 2 exclusively. V_{PP} voltage is controlled by an 8-bit DAC. It is possible to switch V_{PP} on/off by high voltage analog switch.

This Development Board can be used for external chip signal characterization, design test, and analysis. An external I²C port is available for controlling external expansion, such as an oscilloscope test point the Development Board, or LED indicator the Development Board.

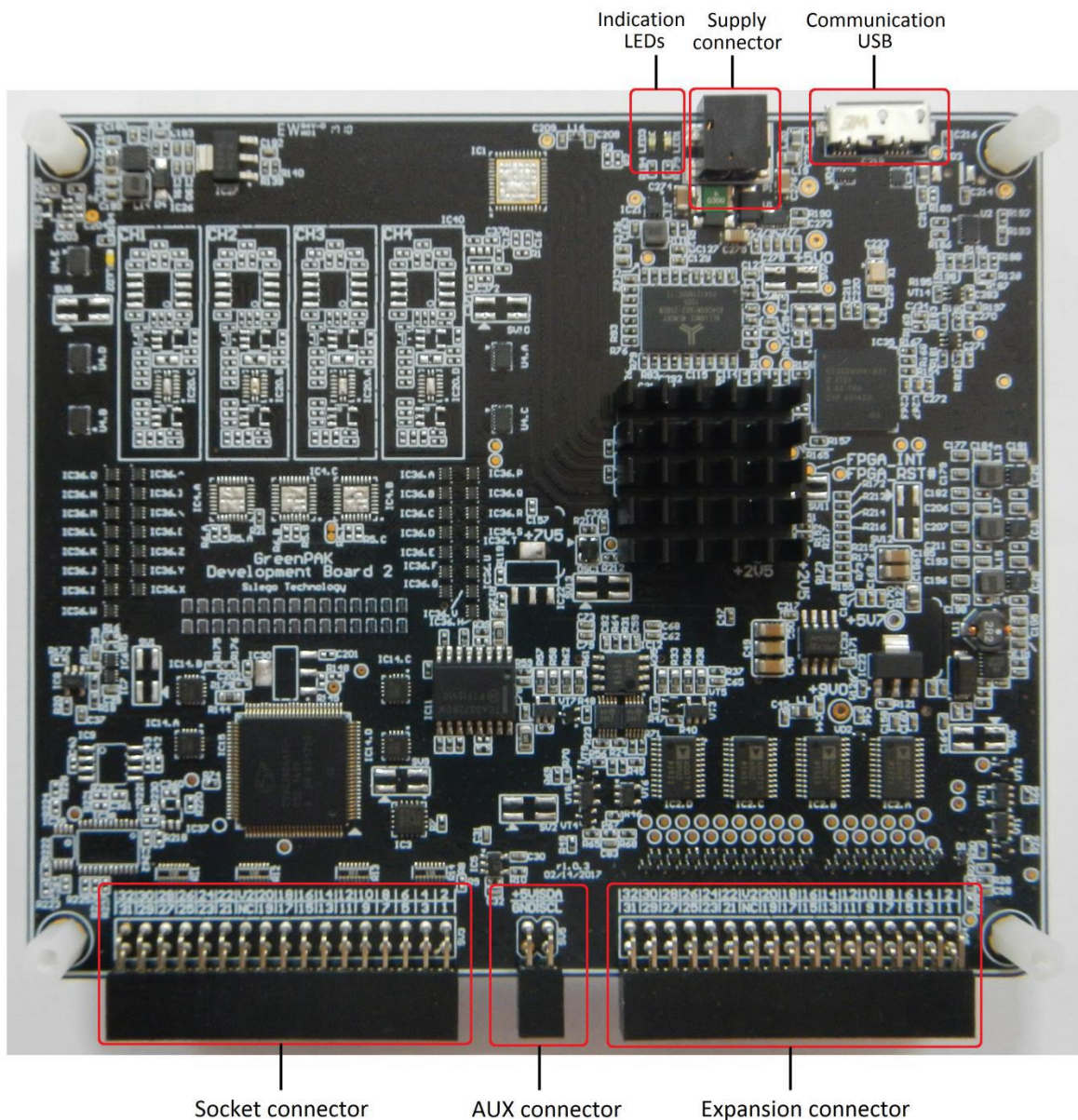

Figure 1: GreenPAK Pro Development Board, Top View

4.2 Functional Description

4.2.1 Power Supply

The main power source of the GreenPAK Pro Development Board is an external power supply that is supplied with the Development Board. Use only power supply that comes with the Development Board. The Development Board will not operate correctly without the external power supply.

4.2.2 USB 3.0 Communication

The Development Board has the USB communications interface that uses the USB 3.0 micro-B connector, as shown on Figure 2. This interface provides communication with the software control tool.

GreenPAK Pro Development Platform

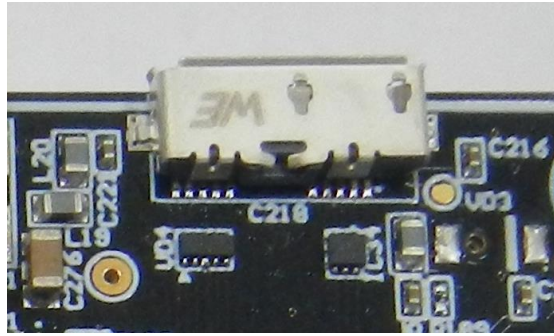

Figure 2: USB Interface

4.2.3 Socket Connector

This 34-pin connector is in the left bottom portion of the Development Board. The Socket Connector is a standard 0.1" double row female connector. The GreenPAK Pro Development Board should be used with a detachable socket board. Its main purpose is to connect the target GreenPAK chip to the Development Board.

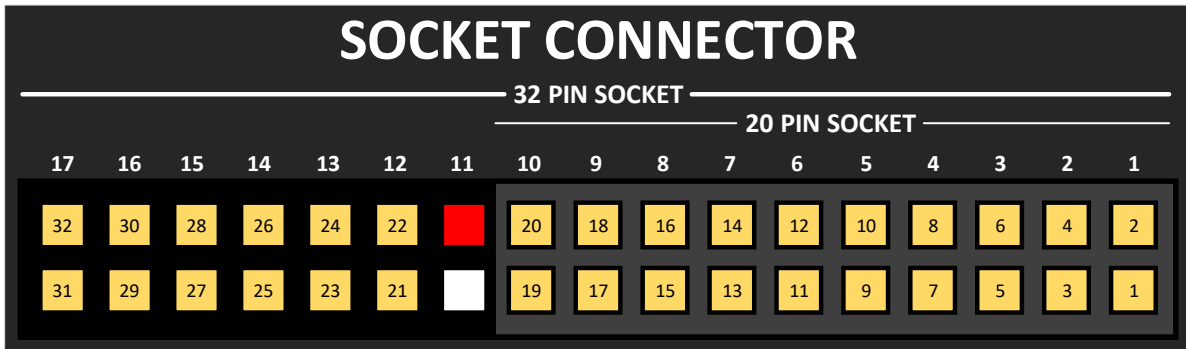

Figure 3: GreenPAK Socket Connector Pinout

4.2.4 Expansion Connector

This 34-pin connector is in the right bottom portion of the Development Board. The Expansion Connector is a standard 0.1" double row female connector. This port was designed to connect the GreenPAK Pro Development Board to external circuits and apply external power, signal sources, and loads. It can be used to connect GreenPAK chip into your custom design with a minimum of additional tools, while maintaining full control over the chip.

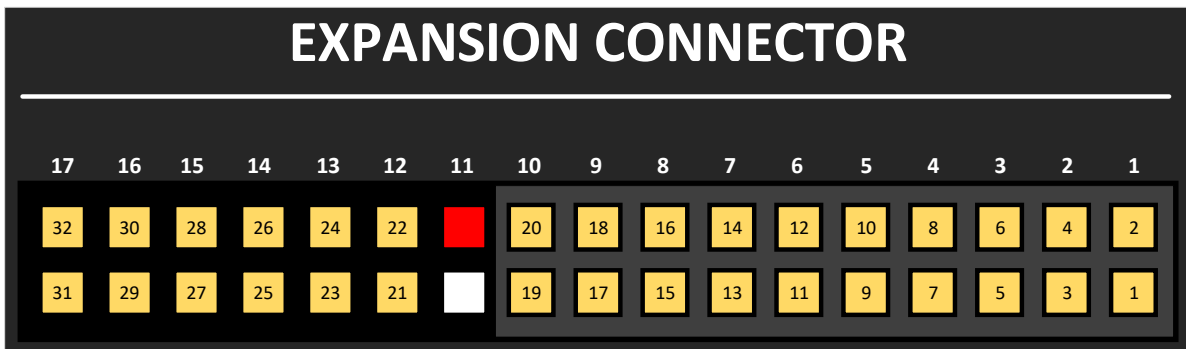

Figure 4: GreenPAK Expansion Connector Pinout

Each pin except GND and NC is controlled through an individual analog switch. GreenPAK Designer can enable or disable external pins, as it is shown on Figure 5. The main purpose of the Expansion

GreenPAK Pro Development Platform

Connector is to connect an external signal/power source safely to the GreenPAK Pro Development Board. In addition, each Expansion Connector line has ESD protection.



Figure 5: Expansion Connector Control in GreenPAK Designer

The Expansion Connector is enabled only in Emulation mode or Test mode. To enter either of these two modes the target GreenPAK device must be inside the socket. When the Test mode button is pressed, the software will first read the chip to verify if it was inserted correctly, and then configure the GreenPAK Pro Development Board as it was set in Emulation mode. After the Emulation button is pressed, the software will automatically perform the following steps:

- Check chip presence;
- Open all expansion port switches (allowing external signals/loads to be left connected to Expansion Connector);
- Load target configuration into the target GreenPAK device using internal power;
- Configure Development Board as it was selected in Emulation Tool window.

Note that the GreenPAK device has internal OTP memory which is normally loaded into RAM registers at initialization time. “Emulation mode” will bypass this load and write the updated version of the project directly into the RAM register inside the GreenPAK chip many times, but after power loss all internal data will be lost. Also, when the GreenPAK chip is already programmed – the User can use Emulation mode to load another project and test it on the emulation tool during the Emulation mode. In that case emulation data will be cleared. The “Emulation mode” is not necessary for checking programmed parts: in this case the “Test mode” will supply power to the device, which will perform the standard load of configuration data from OTP to RAM. The difference between the “Emulation” and the “Test mode” is that in the “Test mode” the process of loading configuration memory is skipped, and after the chip power, the OTP memory loads into RAM registers.

The Expansion Connector has the following type of connections:

1. V_{DD}
2. GND
3. Data connections

The V_{DD} connection allows the User to both use internal power supply to power the external circuit, and use external power source as the on-board chip power. This selection to use either internal or external power is made in the Emulator Controls window.

The GND connection is connected directly to the GreenPAK Pro Development Board ground and cannot be controlled or switched.

Data connections are the easiest way to connect external signals to the GreenPAK chip. They are software controlled switches that are controlled in the Emulator Controls window.

4.2.5 Generators

Three types of generator can be connected to a defined TP: Logic generator, Signal generator, or I²C generator. The user can add generator to highlighted green pins with the help of Add button or use a context menu of the TP.

GreenPAK Pro Development Platform

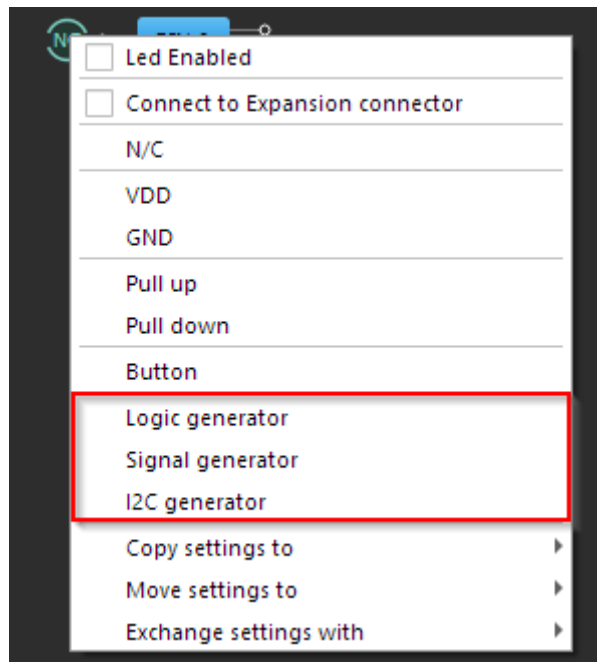

Figure 6: Choosing Generators

Logic generator is used for generating logic pulses.

I²C generator allows the user to create I²C signals based on logic generators. There are two logic generators combined together as SDA and SCL lines. The user can combine predefined I²C settings to generate a needed waveform and choose SCL frequency.

SCL sends I²C-compatible SCL signal to the line. SCL works only in a 'read-only' mode. SCL clock can be configured by choosing predefined frequency. The set of those frequencies depends on the development platform.

SDA sends I²C-compatible SDA signal to the line. In Signal Wizard special editor shows sequence of commands. There are some actions in command editor the user can do.

Signal generator is used to generate analog signals: constant voltage level, sine, trapeze (trapezoid), logic pattern, and user-defined.

There is a possibility to start all the generators using buttons at Debugging controls panel.

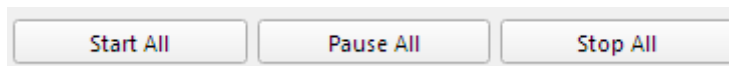

Figure 7: Managing Buttons

Note 1 These buttons can be controlled only by generators with installed Global Linkage flag.



Figure 8: Global Linkage Settings

4.2.6 Pins Connectivity

The Socket connector has the following type of connections:





1. V_{DD}
2. GND
3. Data connections

The GreenPAK Pro Development Board supports connecting eight types of loads and signal sources. Each source has its own special purpose.

For V_{DD} pins only a signal generator connection is available.

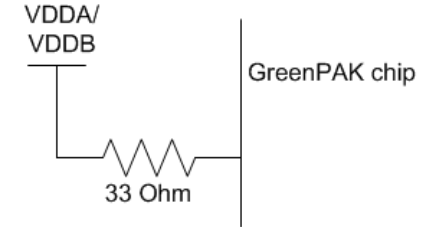
For the Data pins the following connections are available: V_{DD}, GND, Pull-up, Pull-down, Configurable Virtual Button, Signal Generator, Logic Generator.

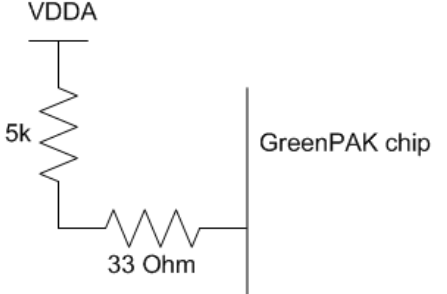
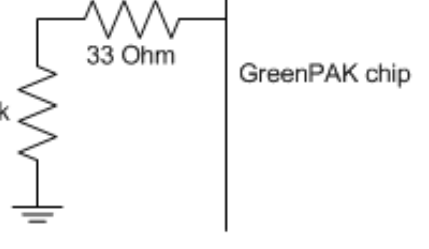
Table 1: Data Pin Connections Schematics

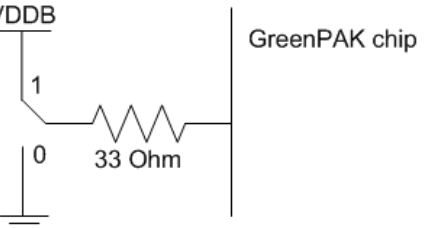
<p>Connect PIN to V_{DDA} or V_{DDB} (Note 2) via level shifter through 33 Ω resistor</p>	 <p style="text-align: center;">Set to VDD</p>	<p>Connect PIN to GND through 33 Ω resistor</p>	 <p style="text-align: center;">Set to GND</p>
<p>Connect PIN to V_{DDA} through MCU 5 kΩ Pull-up resistor + 33 Ω resistor</p>	 <p style="text-align: center;">Pull up</p>	<p>Connect PIN to GND through MCU 5 kΩ Pull Down resistor + 33 Ω Resistor</p>	 <p style="text-align: center;">Pull down</p>
<p>When button released, it connects to bottom connection</p>	 <p style="text-align: center;">Button released</p>	<p>When button pressed, it connects to upper connection</p>	 <p style="text-align: center;">Button pressed</p>

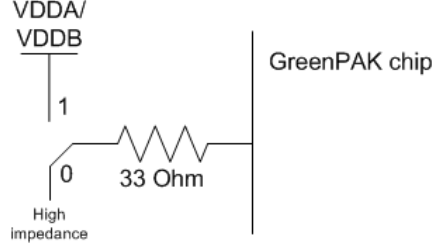
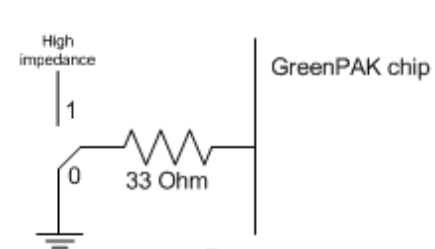
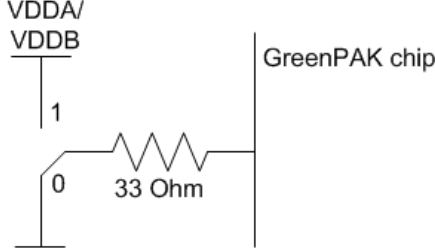
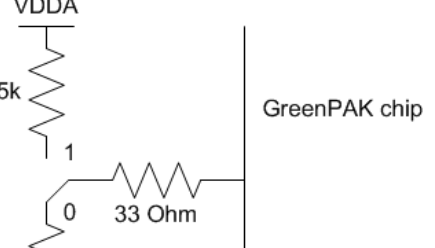
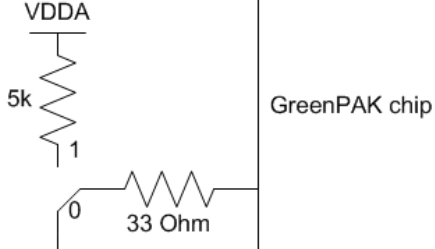
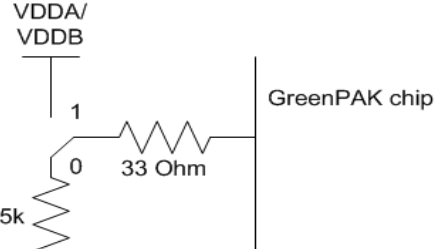
<p>Upper connection to V_{DDA} or V_{DDDB} (Note 2) via level shifter through 33 Ω resistor; bottom connection to high impedance MCU input</p>	 <p style="text-align: center;">Button VDD – HI-Z</p>	<p>Upper connection to high impedance MCU; bottom connection to GND through 33 Ω resistor</p>	 <p style="text-align: center;">Button HI-Z – GND</p>
<p>Upper connection to V_{DDA} or V_{DDDB} (Note 2) via level shifter through 33 Ω resistor; bottom connection to GND through 33 Ω resistor</p>	 <p style="text-align: center;">Button VDD – GND</p>	<p>Upper connection to V_{DDA} through MCU 5 kΩ Pull-up resistor + 33 Ω resistor; bottom connection to GND through MCU 5 kΩ Pull Down resistor + 33 Ω resistor</p>	 <p style="text-align: center;">Button Pull up – Pull down</p>
<p>Upper connection to V_{DDA} or V_{DDDB} (Note 2) through MCU 5 kΩ Pull-up resistor + 33 Ω resistor; bottom connection to GND through 33 Ω resistor</p>	 <p style="text-align: center;">Button Pull up – GND</p>	<p>Upper connection to V_{DDA} or V_{DDDB} (Note 2) via level shifter through 33 Ω resistor; bottom connection to GND through MCU 5 kΩ Pull-down resistor + 33 Ω resistor</p>	 <p style="text-align: center;">Button VDD – Pull down</p>

Note 2 Connection to V_{DDA} or V_{DDDB} depends on which logical voltage level pin belongs to. For this information see chip datasheet.

Figure 9 shows the schematic connection of the GP V_{DD} pins.

GreenPAK Pro Development Platform

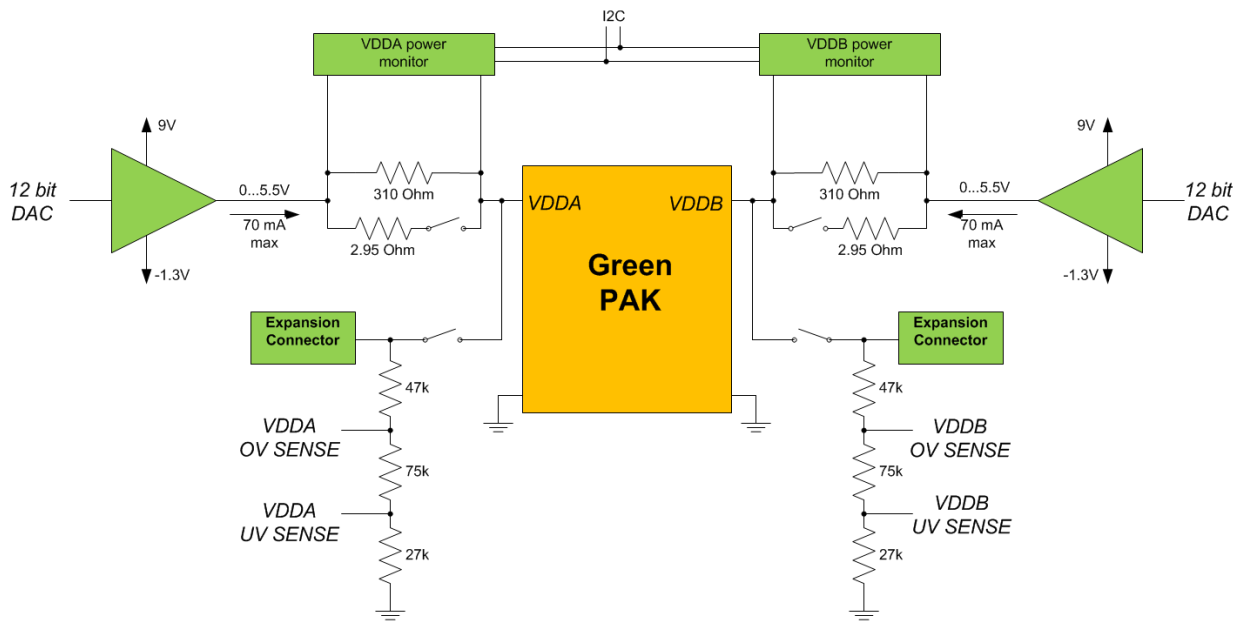

Figure 9: Schematic Connection of the V_{DD} Pin

Figure 10 shows the schematic connection of the GP data pins.

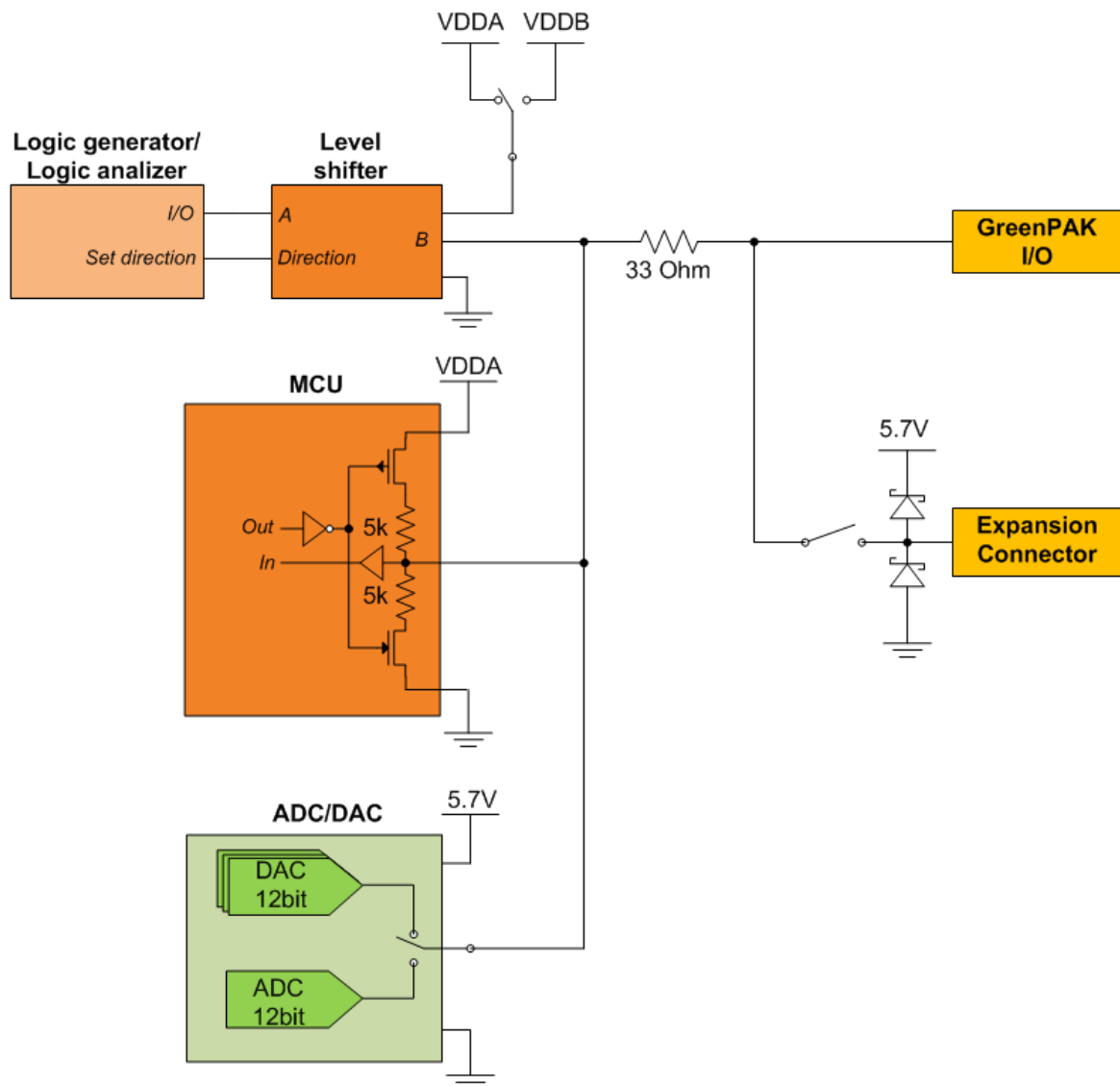

Figure 10: Schematic Connection of the Data Pin

4.2.7 Preparing GreenPAK Pro Development Board

To start working with GreenPAK Pro Development Board it is necessary to:

- Connect external Power Supply;
- Connect Development Board to PC via USB cable;
- Connect socket adapter to the Socket connector (if you would like to work with chip: emulate, program, test);
- Connect test point expansion Development Board to the Expansion connector (if necessary);
- Place chip into the socket.

GreenPAK Pro Development Platform

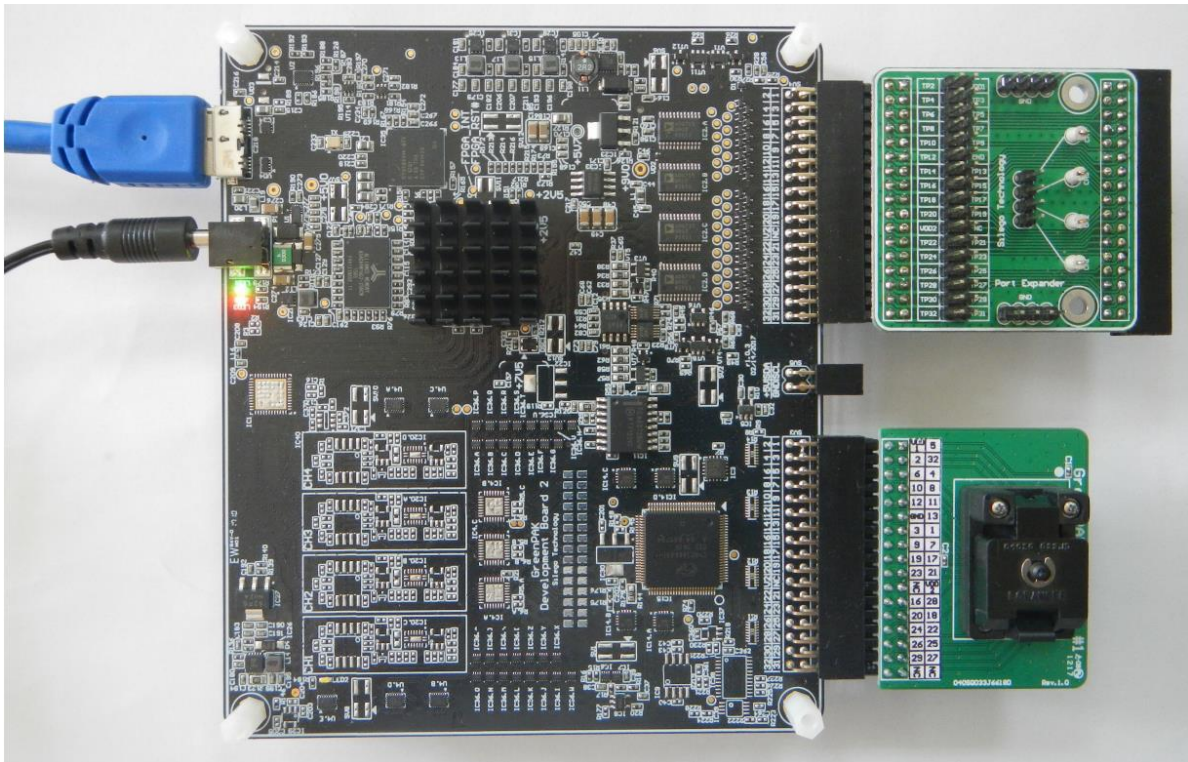

Figure 11: GreenPAK Pro Development Board Ready to Work

4.2.8 Chip PIN versus Development Board Test Point

Before you start working with a chip, you need to understand the difference between such concepts as PIN (chip pin) and TP (the Development Board test point). Figure 12 shows where PINs and TPs are.

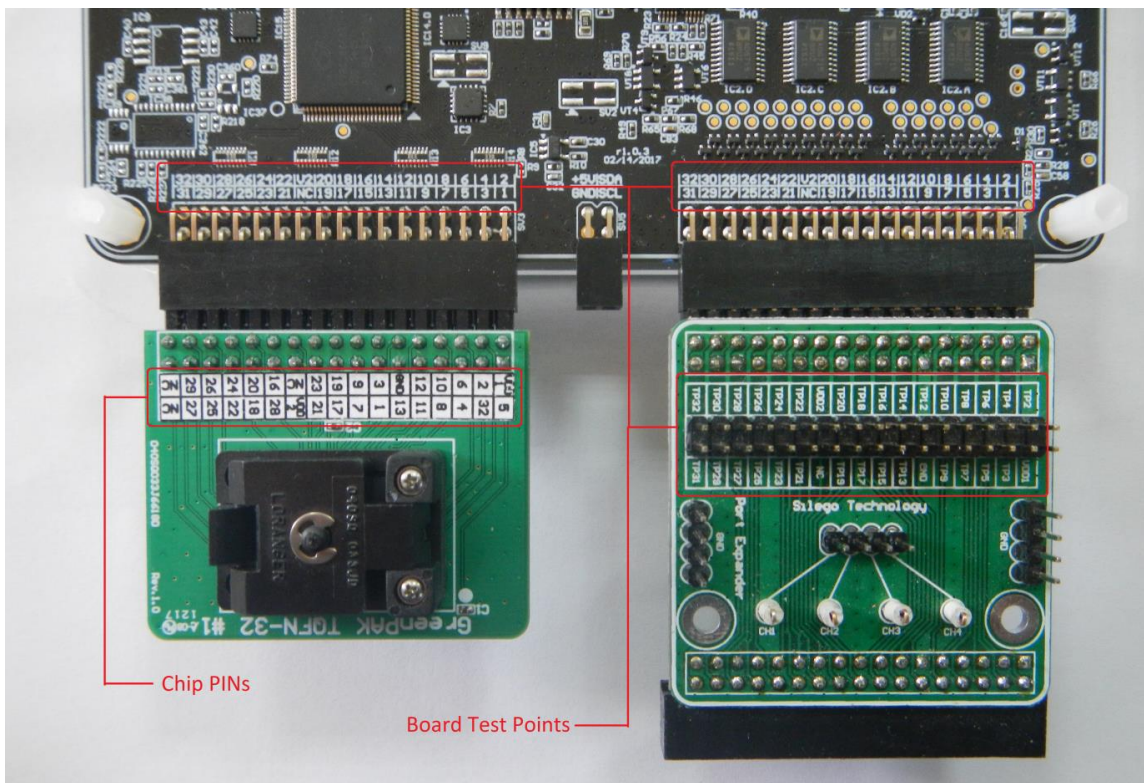

Figure 12: PINs and TPs Location

PINs refer to the physical pins that are on the chip package (their marking can be seen in the datasheet). TPs refer to the Socket and Expansion connector pins. TP and PIN numbers may not match since different PINs on the chip have different functions, see [Figure 13](#).

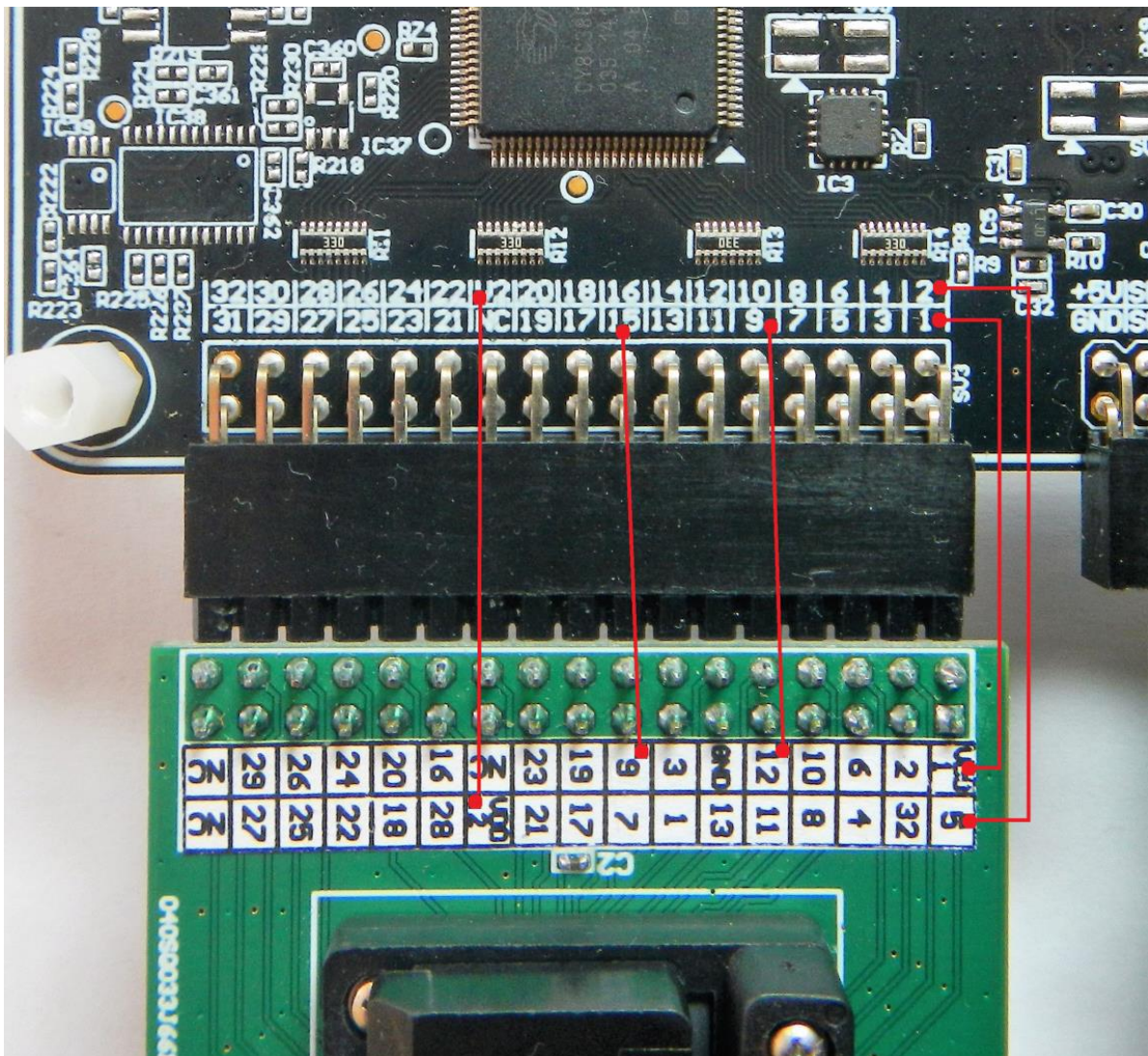

Figure 13: Some PINs and TPs Accordance (for SLG46880V)

In GreenPAK designer you can switch between PINs and TPs display mode. There is the button “TP Map” In Emulation Controls window, which will show this function, see [Figure 28](#).

4.2.9 Using 20 Pins Socket Adapter with 32 Pins Socket Connector

For working with a chip in 20-pin socket you need to connect it to the Development Board Pro Socket connector, as shown in [Figure 14](#). Pin numbering starts from the lower right corner (entire connector pinpoint is shown in [Figure 4](#)).

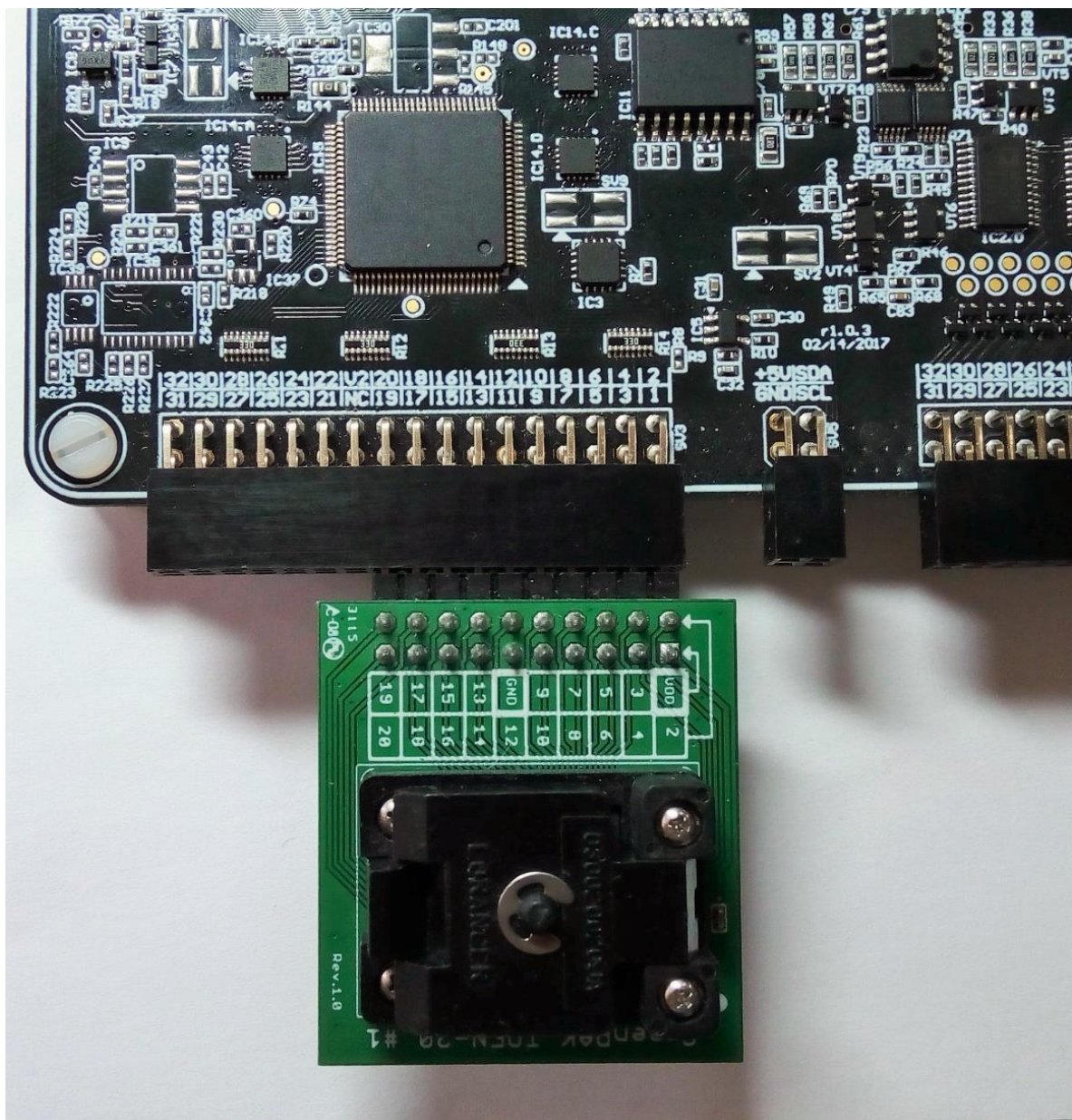

Figure 14: 20 Pins Socket Adapter Connected into 32 Pins Socket Connector

5 Example Projects using SLG46880

5.1 Project: Counter with Clock Enable

Blocks required:

- 2 digital inputs
- 1 digital output
- 2 Look Up Table with two inputs
- 1 Counter

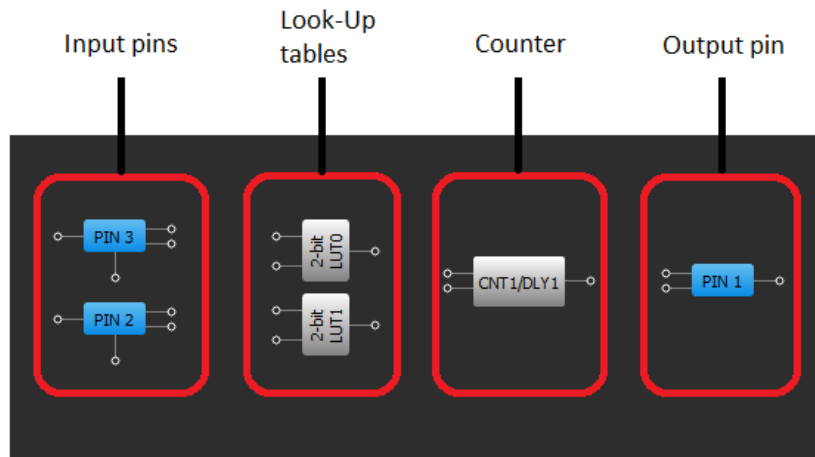

Figure 15: GreenPAK Designer Components

All these components can be found in Components List. If there are no components on the work area - make sure this component is enabled by checking appropriate boxes.

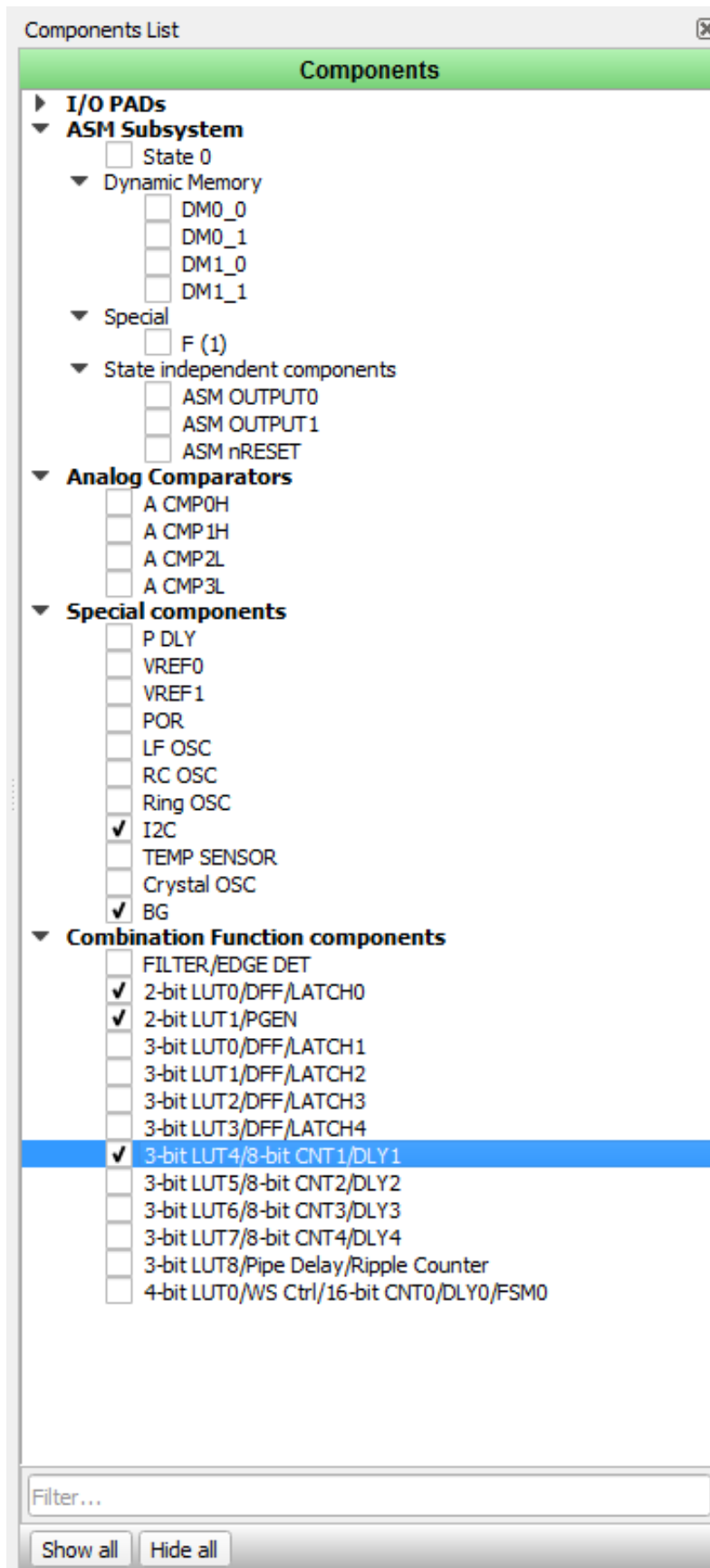

Figure 16: GreenPAK Components List

GreenPAK Pro Development Platform

Table 2: GreenPAK Pin Configuration

Pin #	Pin Name	Type	Pin Description
31	V _{DD1}	PWR	Supply Voltage
15	V _{DD2}	PWR	Supply Voltage
3	Clock	Digital Input	Digital Input
2	Enable	Digital Input	Digital Input
14, 30	GND	GND	Ground
1	Counter Output	Push-Pull Output	Digital Output

All components used in this project are shown on [Figure 15](#). Next step is to configure selected blocks. Double click on PIN1 to open “Properties” panel. Select “Digital output” in **I/O Selection** field and then select “1x push pull” from the drop-down menu in **Output mode** field and hit “Apply” button.

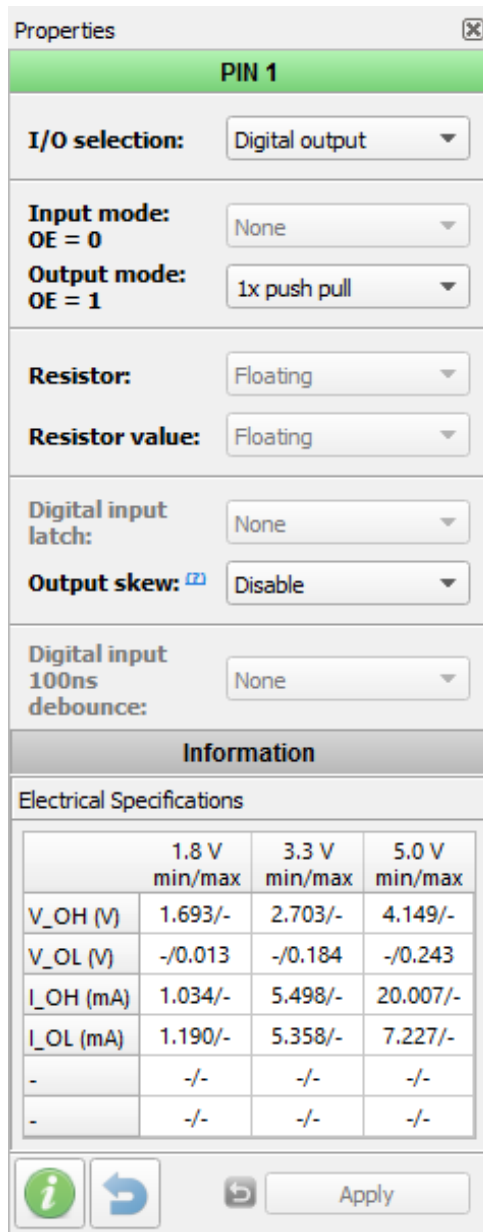

Figure 17: Pin1 Mode

GreenPAK Pro Development Platform

The next component in this design is Look Up Table. First Look Up Table (LUT0) is used to generate logic “1” only when there are high logic levels on both inputs (AND gate). Select AND gate from “Standard gates” drop-down menu or set table manually. Second Look Up Table (LUT1) is configured as NOR gate. It is used to generate reset signal for counter on PIN2 falling edge.

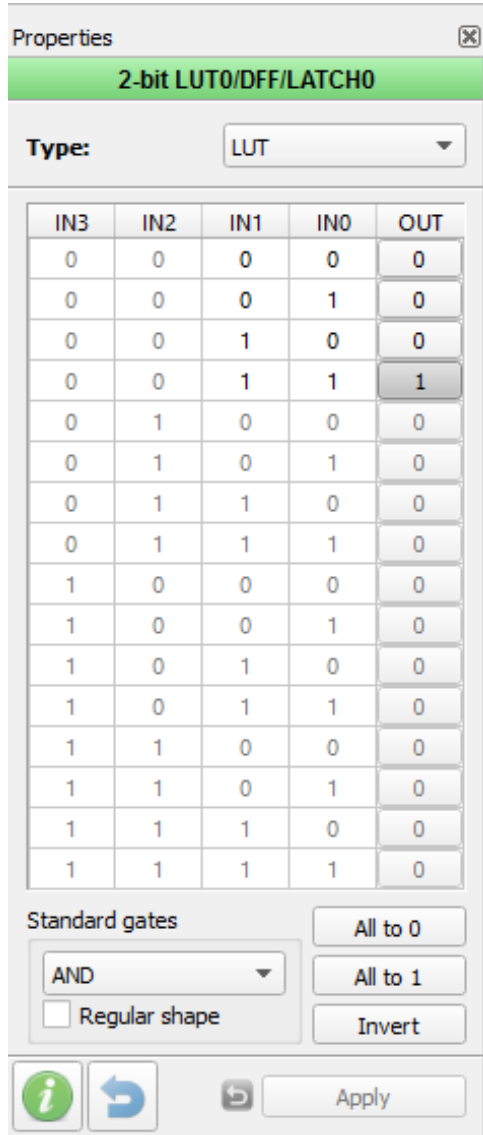

Figure 18: Look Up Table Properties Configured as an AND Gate

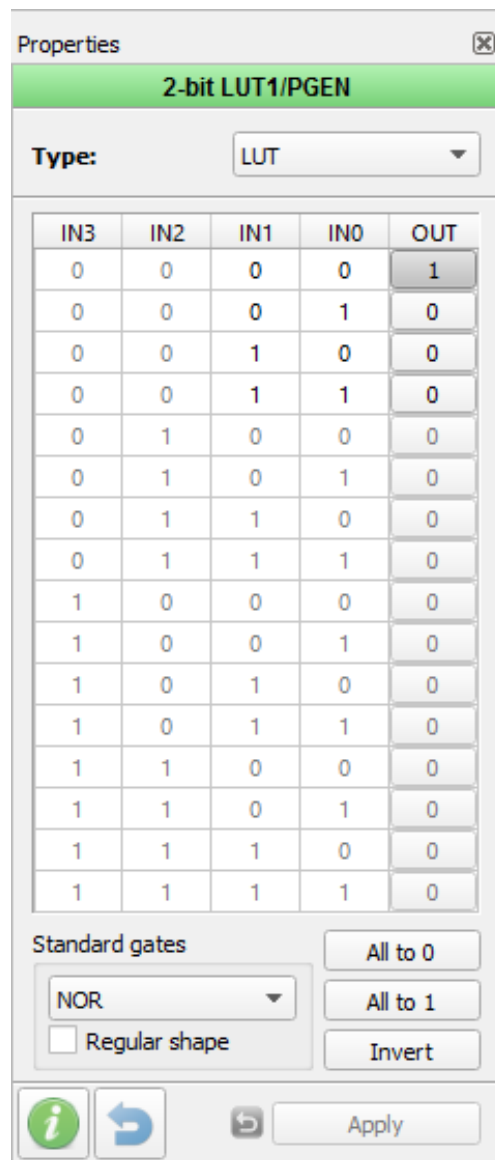

Figure 19: Look Up Table Properties Configured as a NOR Gate

Figure 20 shows counter properties.

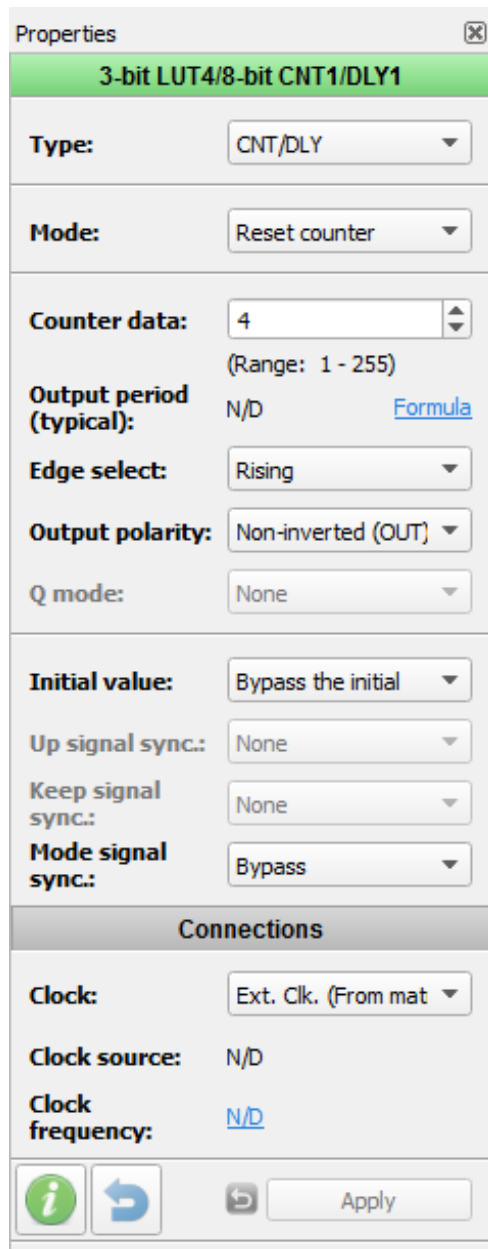



Figure 20: Counter Properties

The Final step is to connect each of the selected components. Use Wire tool to perform this action. To connect two pins select “Set Wire”  and then click on the first and the second pins of the module or modules that you want to connect. The trace will be automatically routed.

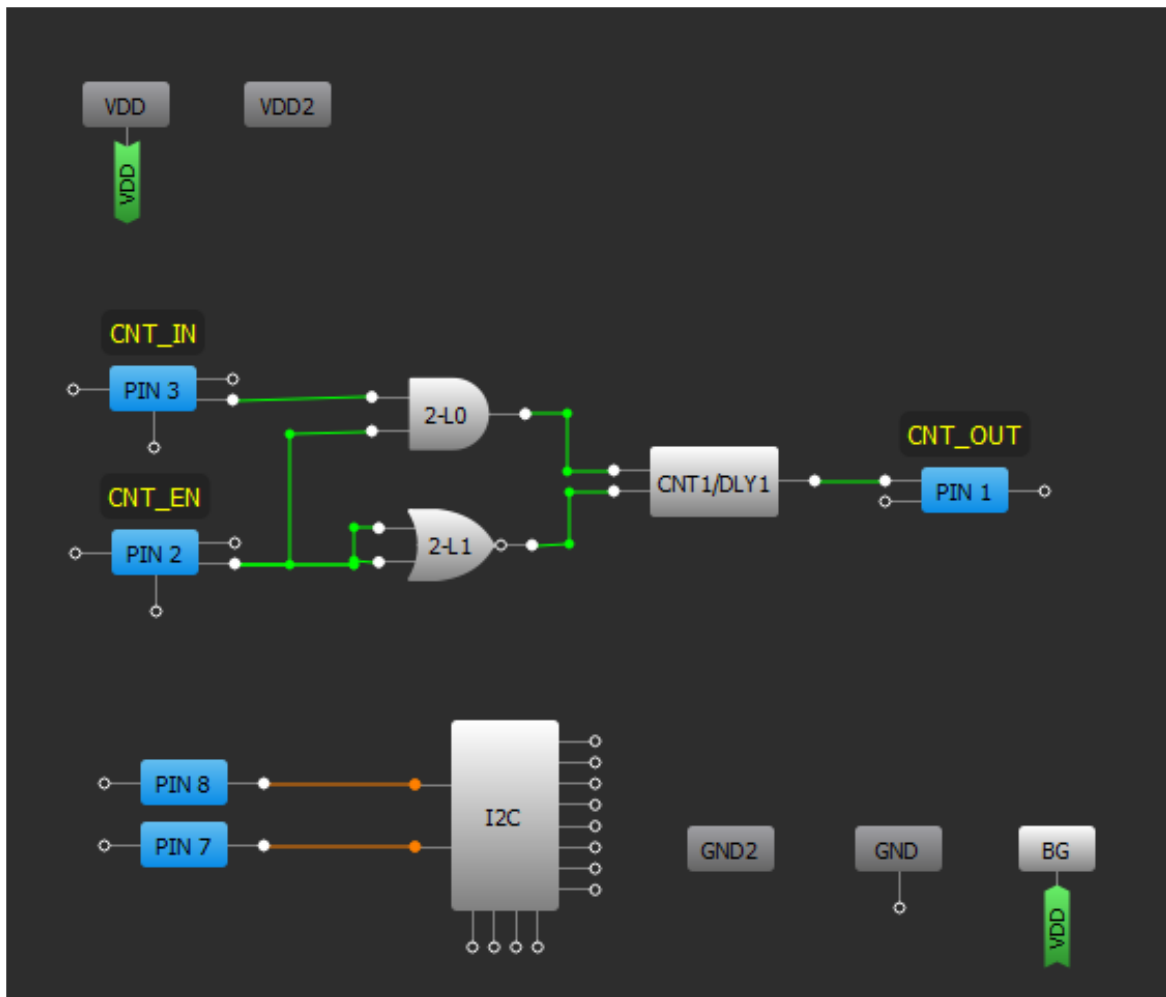

Figure 21: Ready Project in GreenPAK Designer

Figure 21 displays ready project with configured blocks and wire connections.

Use the GreenPAK Pro Development Board to test this project. Prepare the Development Board to work, see Section 4.2.7, and press “Emulator” button. Wait until the initialization process of GreenPAK Pro Development Board is in progress. In emulation mode you are able to add sources/loads to GreenPAK pins using additional emulation toolbar, see Figure 22.

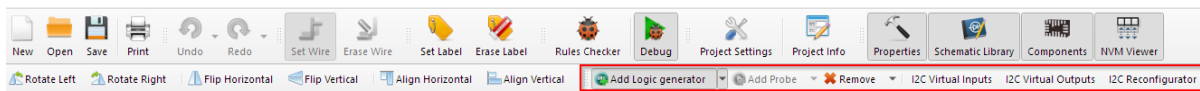

Figure 22: Additional Emulation Toolbar in Emulation Mode

To test this project, we will use the following tools:

- Signal generator. Signal generator is applied to V_{DD} pin to power GreenPAK chip;
- Logic generator. Logic generator serves as clock source;
- Button is a software simulation of the real button. It switches PIN between V_{DD} and GND signal levels.

The Signal generator is presented as power source for the GreenPAK chip (at V_{DD} and V_{DD2} pins). The values for V_{DD} and V_{DD2} will match the selections made in the Project Info window by default. To see signal generators settings double-click on the generator icon near the pin V_{DD} or V_{DD2}.

Figure 23 shows signal generator settings window.

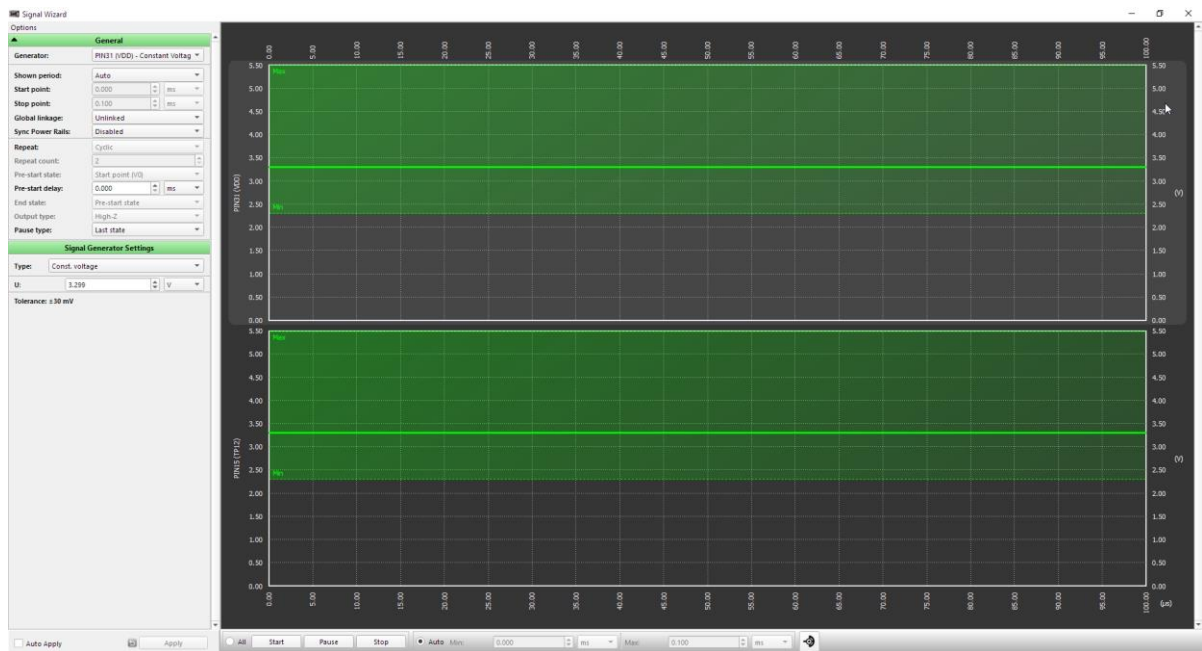

Figure 23: Generator Settings Window

It is necessary to connect logical generator to the PIN3, and to the PIN 2 button. To do so click on “Add” menu from Additional emulation toolbar and from the drop-down menu select needed tool, see Figure 24.

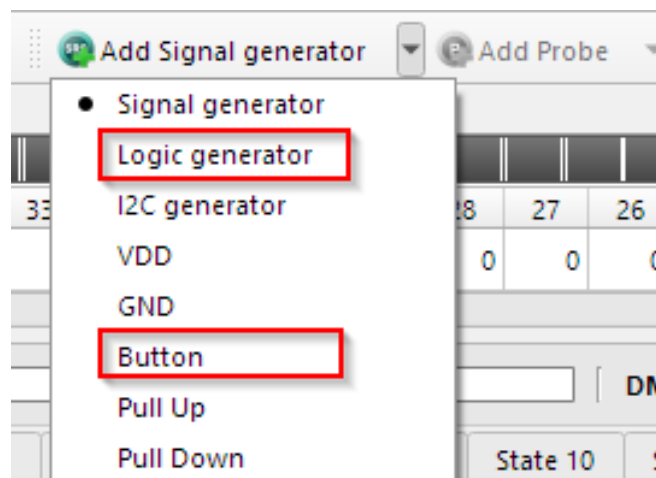

Figure 24: “Add” Menu List

After this click on point near “EXT IN/OUT” pin output, see Figure 25 (after you selected needed item in “Add” menu, “EXT IN/OUT” pin will change color on light green).

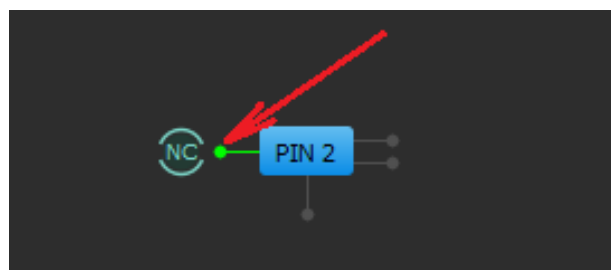

Figure 25: “EXT IN/OUT” Pin Output

After all settings have done, signal label near pin will change in accordance with the selected tool. When mouse move on signal label, it shows available tools in pop-up control panel, see [Figure 26](#).

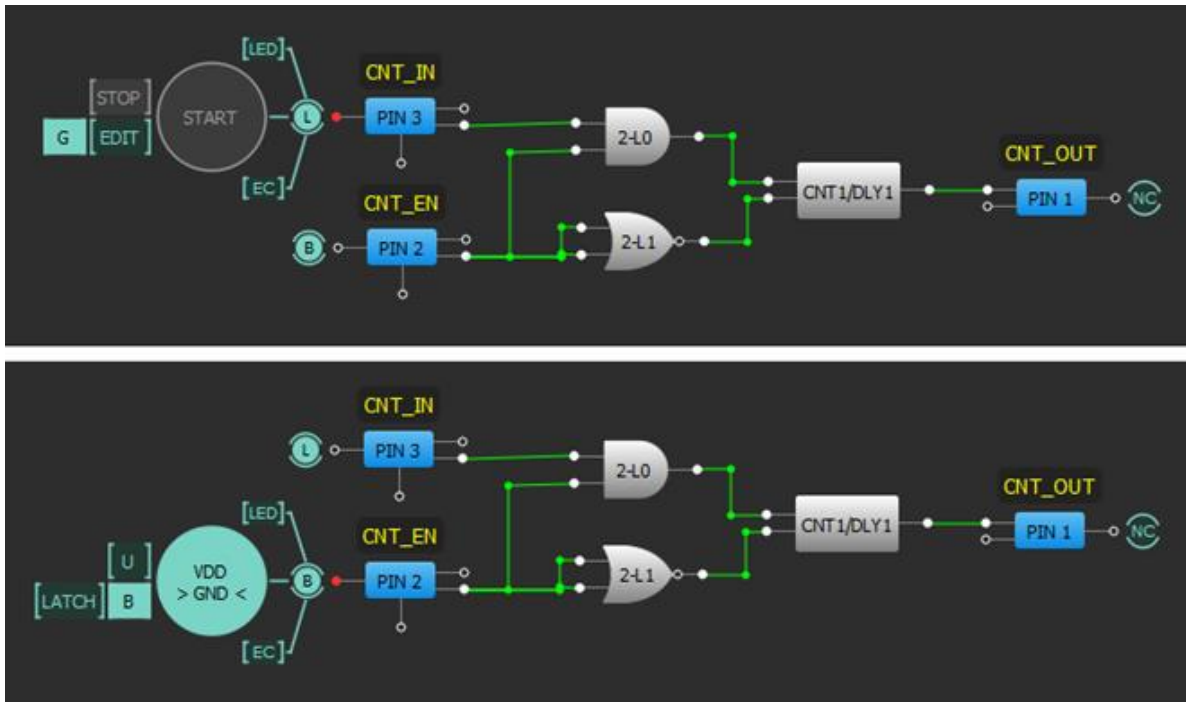

Figure 26: Signal Labels and Control Panels

The purpose of the logic generator is to provide clock pulses for the Counter block. It is configured for 10 Hz clock source as shown on [Figure 27](#).

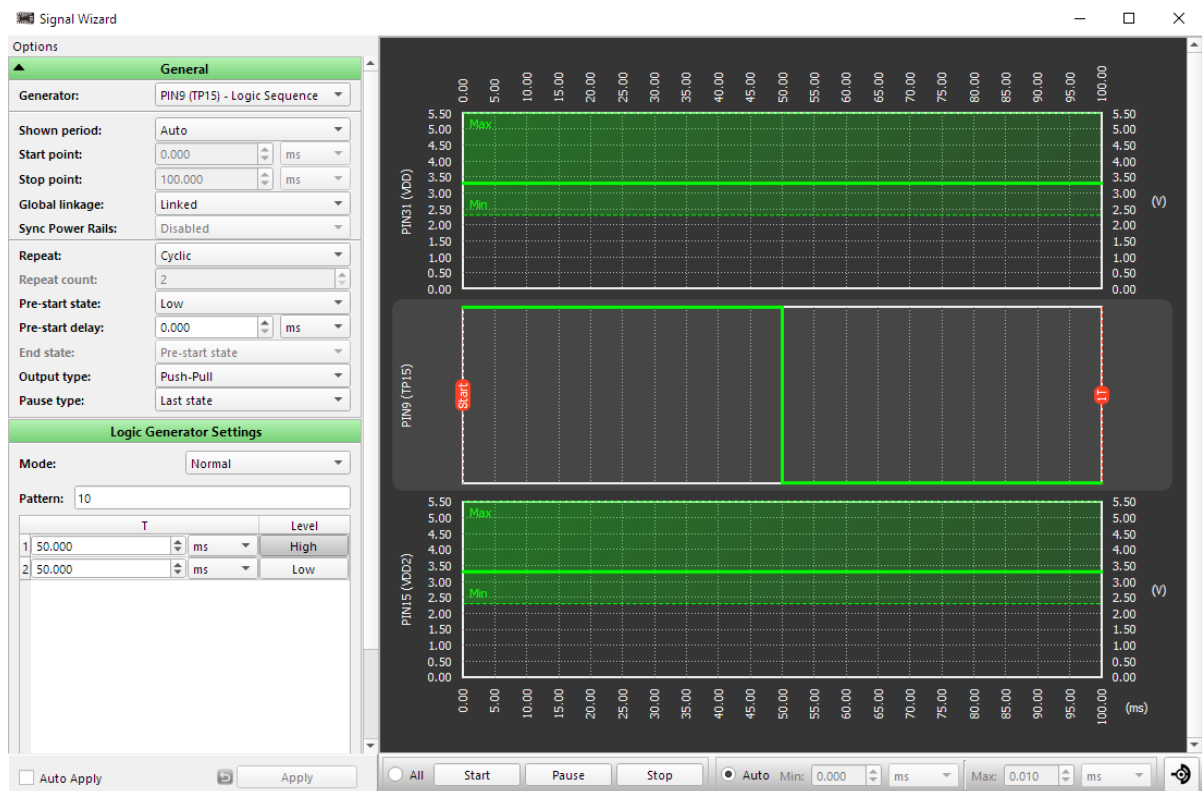

Figure 27: Logic Generator Properties

After all settings are done, click button “Emulation” from Emulation Controls window to start emulation process.

To start all logic and signal generators (except V_{DD}/V_{DD2} signal generators) press button “Start All”, see Figure 28.

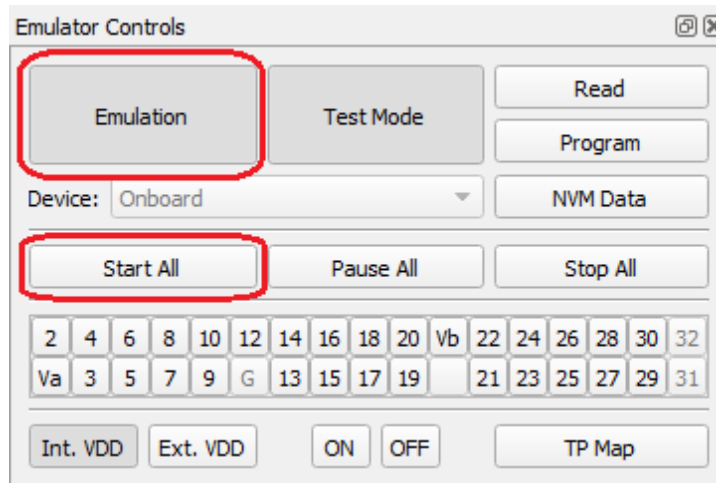

Figure 28: Emulator Controls Window

Functionality Waveform

Channel 1 (yellow/top) – Logic generator

Channel 2 (light blue/2nd line) – Button, 1 - enable Counter; 0 - disable Counter

Channel 3 (magenta/3rd line) – Counter output

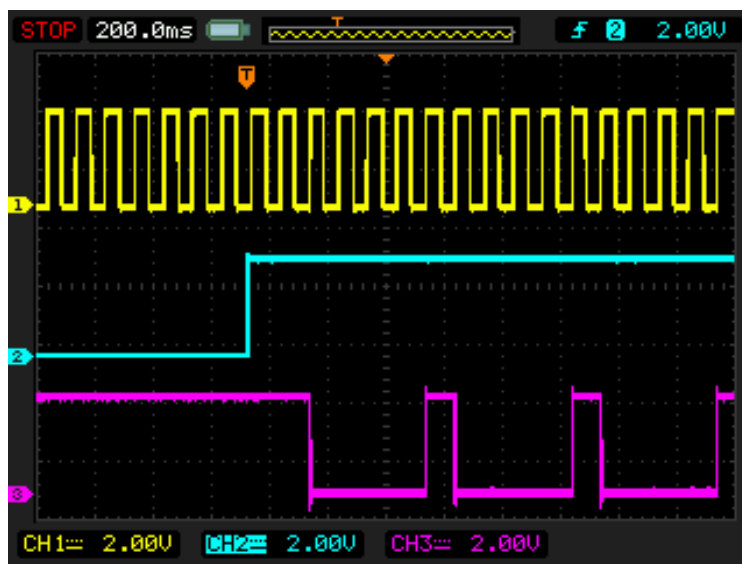

Figure 29: Waveform, Triggered on Button Pressed

Channel 1 (yellow/top) – Logic generator

Channel 2 (light blue/2nd line) – Button, 1 - enable Counter; 0 - disable Counter

Channel 3 (magenta/3rd line) – Counter output

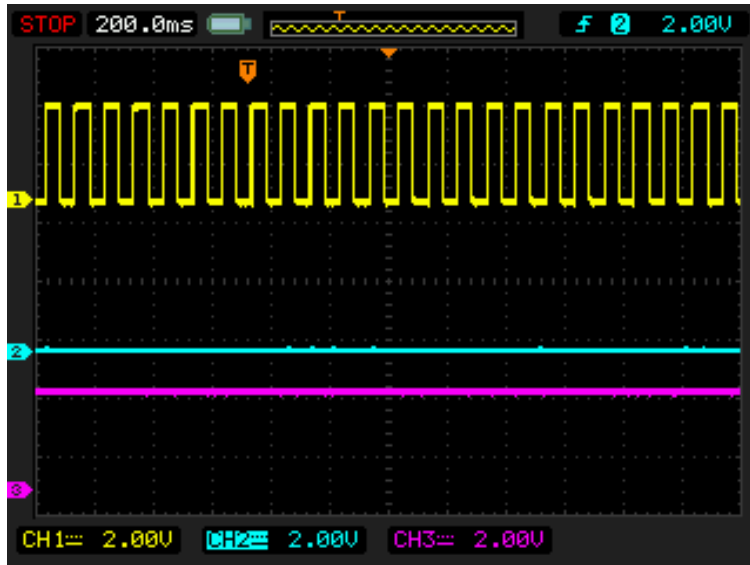

Figure 30: Waveform, no Triggered on Button Released

Channel 1 (yellow/top) – Logic generator
 Channel 2 (light blue/2nd line) – Button, 1 - enable Counter; 0 - disable Counter
 Channel 3 (magenta/3rd line) – Counter output

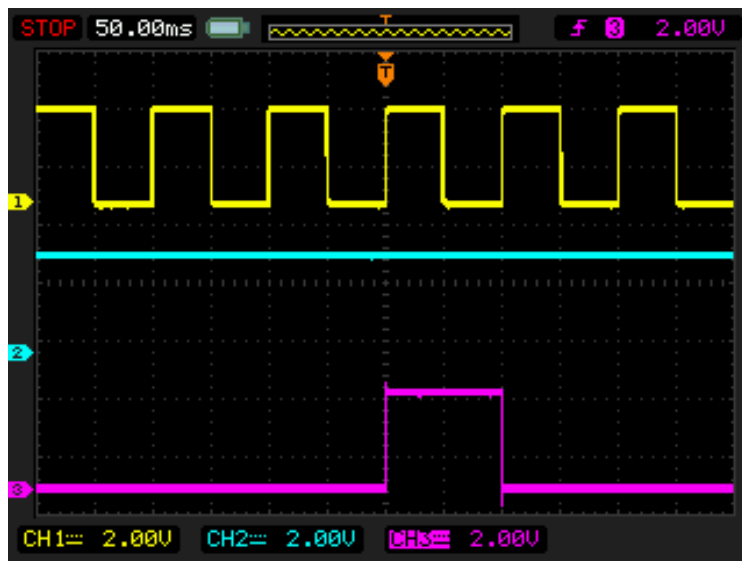

Figure 31: Waveform of the Pulse Width of the Logic Generator and Count End Signal

As it is shown in [Figure 30](#) and [Figure 31](#) Counter works only when the button is pressed.

6 Conclusion

This GreenPAK Pro Development Platform is a truly versatile tool. It allows the designer to create a custom project within minutes, without using additional devices (except oscilloscope).

For more information please visit our website www.renesas.com.

Appendix A Electrical Specification

Mode	Parameter	Min	Typ	Max	Units
General	Test Point Capacitance	55	--	--	pF
	Input Leakage Current	--	--	5	nA
	Max Current through Protection Diode to V _{DD}	--	--	200	mA
Power Supply (V _{DDA} /V _{DDB})	Voltage Range	0	--	5.5	V
	V _{DD} Max Current	--	--	70	mA
	Voltage Output Total Error	--	--	±30	mV
Logic generator	Number of Channels	--	--	30	--
	Output Voltage High	--	V _{DDA} V _{DDB}	--	V
	Output Voltage Low	--	--	0.8	V
	Max Current per TP	--	--	50	mA
	Rise Time	2.5	--	--	ns
	Fall Time	3	--	--	ns
	Max Output Frequency	0.152	--	12.5	MHz
	Max Number of Points	--	--	180	--
Signal Generator	Sample Rate	--	25000	--	kSPS
	Number of Channels	--	--	32	--
	Output Voltage Range	0	--	5.5	V
	DC Output Impedance	--	0.2	--	Ω
	Short-Circuit Current	--	--	25	mA
	Min Output Voltage	--	--	2	mV
	Output Total Error	--	--	±7	mV
	Output Frequency (SINE)	0.01	--	5000	Hz
	Max Number of Points	--	--	512	--
Virtual Button, V _{DD} /GND, Pull-Up/Down Driver	Sample Rate	--	100	--	kSPS
	Output Level High	--	V _{DDA} V _{DDB}	--	--
	Output Level High (Pull-Up)	--	V _{DDA}	--	--
	Output Level Low	--	GND	--	--
	Strong Drive (V _{DD} /GND) Resistance	--	33	--	Ω
Expansion Connector Switch	Pull-Up/Down Resistance	3.5	5.6	8.5	kΩ
	Max Voltage	--	--	5.5	V
	Continuous Current through Any Terminal	--	--	±30	mA
	Switch On-Resistance	--	2.5	5	Ω
	External V _{DD} Switch On-Resistance	--	--	100	Ω
	On Leakage Current	-0.1	--	0.1	nA
	Off Leakage Current	-0.1	--	0.1	nA
Bandwidth	--	150	--	MHz	

Revision History

Revision	Date	Description
1.2	21-Mar-2022	Renesas rebranding
1.1	15-Sep-2021	Added section Generators Updated according to Dialog's Writing Guideline

GreenPAK Pro Development Platform

Status Definitions

Status	Definition
DRAFT	The content of this document is under review and subject to formal approval, which may result in modifications or additions.
APPROVED or unmarked	The content of this document has been approved for publication.

RoHS Compliance

Renesas Electronics Corporation's suppliers certify that its products are in compliance with the requirements of Directive 2011/65/EU of the European Parliament on the restriction of the use of certain hazardous substances in electrical and electronic equipment. RoHS certificates from our suppliers are available on request.

IMPORTANT NOTICE AND DISCLAIMER

RENESAS ELECTRONICS CORPORATION AND ITS SUBSIDIARIES (“RENESAS”) PROVIDES TECHNICAL SPECIFICATIONS AND RELIABILITY DATA (INCLUDING DATASHEETS), DESIGN RESOURCES (INCLUDING REFERENCE DESIGNS), APPLICATION OR OTHER DESIGN ADVICE, WEB TOOLS, SAFETY INFORMATION, AND OTHER RESOURCES “AS IS” AND WITH ALL FAULTS, AND DISCLAIMS ALL WARRANTIES, EXPRESS OR IMPLIED, INCLUDING, WITHOUT LIMITATION, ANY IMPLIED WARRANTIES OF MERCHANTABILITY, FITNESS FOR A PARTICULAR PURPOSE, OR NON-INFRINGEMENT OF THIRD-PARTY INTELLECTUAL PROPERTY RIGHTS.

These resources are intended for developers who are designing with Renesas products. You are solely responsible for (1) selecting the appropriate products for your application, (2) designing, validating, and testing your application, and (3) ensuring your application meets applicable standards, and any other safety, security, or other requirements. These resources are subject to change without notice. Renesas grants you permission to use these resources only to develop an application that uses Renesas products. Other reproduction or use of these resources is strictly prohibited. No license is granted to any other Renesas intellectual property or to any third-party intellectual property. Renesas disclaims responsibility for, and you will fully indemnify Renesas and its representatives against, any claims, damages, costs, losses, or liabilities arising from your use of these resources. Renesas' products are provided only subject to Renesas' Terms and Conditions of Sale or other applicable terms agreed to in writing. No use of any Renesas resources expands or otherwise alters any applicable warranties or warranty disclaimers for these products.

(Disclaimer Rev.1.01 Jan 2024)

Corporate Headquarters

TOYOSU FORESIA, 3-2-24 Toyosu,
Koto-ku, Tokyo 135-0061, Japan
www.renesas.com

Trademarks

Renesas and the Renesas logo are trademarks of Renesas Electronics Corporation. All trademarks and registered trademarks are the property of their respective owners.

Contact Information

For further information on a product, technology, the most up-to-date version of a document, or your nearest sales office, please visit www.renesas.com/contact-us/.