

To our customers,

---

## Old Company Name in Catalogs and Other Documents

---

On April 1<sup>st</sup>, 2010, NEC Electronics Corporation merged with Renesas Technology Corporation, and Renesas Electronics Corporation took over all the business of both companies. Therefore, although the old company name remains in this document, it is a valid Renesas Electronics document. We appreciate your understanding.

Renesas Electronics website: <http://www.renesas.com>

April 1<sup>st</sup>, 2010  
Renesas Electronics Corporation

Issued by: Renesas Electronics Corporation (<http://www.renesas.com>)

Send any inquiries to <http://www.renesas.com/inquiry>.

## Notice

1. All information included in this document is current as of the date this document is issued. Such information, however, is subject to change without any prior notice. Before purchasing or using any Renesas Electronics products listed herein, please confirm the latest product information with a Renesas Electronics sales office. Also, please pay regular and careful attention to additional and different information to be disclosed by Renesas Electronics such as that disclosed through our website.
2. Renesas Electronics does not assume any liability for infringement of patents, copyrights, or other intellectual property rights of third parties by or arising from the use of Renesas Electronics products or technical information described in this document. No license, express, implied or otherwise, is granted hereby under any patents, copyrights or other intellectual property rights of Renesas Electronics or others.
3. You should not alter, modify, copy, or otherwise misappropriate any Renesas Electronics product, whether in whole or in part.
4. Descriptions of circuits, software and other related information in this document are provided only to illustrate the operation of semiconductor products and application examples. You are fully responsible for the incorporation of these circuits, software, and information in the design of your equipment. Renesas Electronics assumes no responsibility for any losses incurred by you or third parties arising from the use of these circuits, software, or information.
5. When exporting the products or technology described in this document, you should comply with the applicable export control laws and regulations and follow the procedures required by such laws and regulations. You should not use Renesas Electronics products or the technology described in this document for any purpose relating to military applications or use by the military, including but not limited to the development of weapons of mass destruction. Renesas Electronics products and technology may not be used for or incorporated into any products or systems whose manufacture, use, or sale is prohibited under any applicable domestic or foreign laws or regulations.
6. Renesas Electronics has used reasonable care in preparing the information included in this document, but Renesas Electronics does not warrant that such information is error free. Renesas Electronics assumes no liability whatsoever for any damages incurred by you resulting from errors in or omissions from the information included herein.
7. Renesas Electronics products are classified according to the following three quality grades: "Standard", "High Quality", and "Specific". The recommended applications for each Renesas Electronics product depends on the product's quality grade, as indicated below. You must check the quality grade of each Renesas Electronics product before using it in a particular application. You may not use any Renesas Electronics product for any application categorized as "Specific" without the prior written consent of Renesas Electronics. Further, you may not use any Renesas Electronics product for any application for which it is not intended without the prior written consent of Renesas Electronics. Renesas Electronics shall not be in any way liable for any damages or losses incurred by you or third parties arising from the use of any Renesas Electronics product for an application categorized as "Specific" or for which the product is not intended where you have failed to obtain the prior written consent of Renesas Electronics. The quality grade of each Renesas Electronics product is "Standard" unless otherwise expressly specified in a Renesas Electronics data sheets or data books, etc.

"Standard": Computers; office equipment; communications equipment; test and measurement equipment; audio and visual equipment; home electronic appliances; machine tools; personal electronic equipment; and industrial robots.

"High Quality": Transportation equipment (automobiles, trains, ships, etc.); traffic control systems; anti-disaster systems; anti-crime systems; safety equipment; and medical equipment not specifically designed for life support.

"Specific": Aircraft; aerospace equipment; submersible repeaters; nuclear reactor control systems; medical equipment or systems for life support (e.g. artificial life support devices or systems), surgical implantations, or healthcare intervention (e.g. excision, etc.), and any other applications or purposes that pose a direct threat to human life.

8. You should use the Renesas Electronics products described in this document within the range specified by Renesas Electronics, especially with respect to the maximum rating, operating supply voltage range, movement power voltage range, heat radiation characteristics, installation and other product characteristics. Renesas Electronics shall have no liability for malfunctions or damages arising out of the use of Renesas Electronics products beyond such specified ranges.
9. Although Renesas Electronics endeavors to improve the quality and reliability of its products, semiconductor products have specific characteristics such as the occurrence of failure at a certain rate and malfunctions under certain use conditions. Further, Renesas Electronics products are not subject to radiation resistance design. Please be sure to implement safety measures to guard them against the possibility of physical injury, and injury or damage caused by fire in the event of the failure of a Renesas Electronics product, such as safety design for hardware and software including but not limited to redundancy, fire control and malfunction prevention, appropriate treatment for aging degradation or any other appropriate measures. Because the evaluation of microcomputer software alone is very difficult, please evaluate the safety of the final products or system manufactured by you.
10. Please contact a Renesas Electronics sales office for details as to environmental matters such as the environmental compatibility of each Renesas Electronics product. Please use Renesas Electronics products in compliance with all applicable laws and regulations that regulate the inclusion or use of controlled substances, including without limitation, the EU RoHS Directive. Renesas Electronics assumes no liability for damages or losses occurring as a result of your noncompliance with applicable laws and regulations.
11. This document may not be reproduced or duplicated, in any form, in whole or in part, without prior written consent of Renesas Electronics.
12. Please contact a Renesas Electronics sales office if you have any questions regarding the information contained in this document or Renesas Electronics products, or if you have any other inquiries.

(Note 1) "Renesas Electronics" as used in this document means Renesas Electronics Corporation and also includes its majority-owned subsidiaries.

(Note 2) "Renesas Electronics product(s)" means any product developed or manufactured by or for Renesas Electronics.

# H8 Family E10T-USB Emulator

Additional Document for User's Manual  
Supplementary Information on Using  
the H8/3048F-ONE and H8/3029F

Renesas Microcomputer Development  
Environment System

H8 Family / H8/300H Series

E10T-USB for H8/3048F-ONE HS3048BTCU01HE



## Notes regarding these materials

1. This document is provided for reference purposes only so that Renesas customers may select the appropriate Renesas products for their use. Renesas neither makes warranties or representations with respect to the accuracy or completeness of the information contained in this document nor grants any license to any intellectual property rights or any other rights of Renesas or any third party with respect to the information in this document.
2. Renesas shall have no liability for damages or infringement of any intellectual property or other rights arising out of the use of any information in this document, including, but not limited to, product data, diagrams, charts, programs, algorithms, and application circuit examples.
3. You should not use the products or the technology described in this document for the purpose of military applications such as the development of weapons of mass destruction or for the purpose of any other military use. When exporting the products or technology described herein, you should follow the applicable export control laws and regulations, and procedures required by such laws and regulations.
4. All information included in this document such as product data, diagrams, charts, programs, algorithms, and application circuit examples, is current as of the date this document is issued. Such information, however, is subject to change without any prior notice. Before purchasing or using any Renesas products listed in this document, please confirm the latest product information with a Renesas sales office. Also, please pay regular and careful attention to additional and different information to be disclosed by Renesas such as that disclosed through our website. (<http://www.renesas.com>)
5. Renesas has used reasonable care in compiling the information included in this document, but Renesas assumes no liability whatsoever for any damages incurred as a result of errors or omissions in the information included in this document.
6. When using or otherwise relying on the information in this document, you should evaluate the information in light of the total system before deciding about the applicability of such information to the intended application. Renesas makes no representations, warranties or guaranties regarding the suitability of its products for any particular application and specifically disclaims any liability arising out of the application and use of the information in this document or Renesas products.
7. With the exception of products specified by Renesas as suitable for automobile applications, Renesas products are not designed, manufactured or tested for applications or otherwise in systems the failure or malfunction of which may cause a direct threat to human life or create a risk of human injury or which require especially high quality and reliability such as safety systems, or equipment or systems for transportation and traffic, healthcare, combustion control, aerospace and aeronautics, nuclear power, or undersea communication transmission. If you are considering the use of our products for such purposes, please contact a Renesas sales office beforehand. Renesas shall have no liability for damages arising out of the uses set forth above.
8. Notwithstanding the preceding paragraph, you should not use Renesas products for the purposes listed below:
  - (1) artificial life support devices or systems
  - (2) surgical implantations
  - (3) healthcare intervention (e.g., excision, administration of medication, etc.)
  - (4) any other purposes that pose a direct threat to human lifeRenesas shall have no liability for damages arising out of the uses set forth in the above and purchasers who elect to use Renesas products in any of the foregoing applications shall indemnify and hold harmless Renesas Technology Corp., its affiliated companies and their officers, directors, and employees against any and all damages arising out of such applications.
9. You should use the products described herein within the range specified by Renesas, especially with respect to the maximum rating, operating supply voltage range, movement power voltage range, heat radiation characteristics, installation and other product characteristics. Renesas shall have no liability for malfunctions or damages arising out of the use of Renesas products beyond such specified ranges.
10. Although Renesas endeavors to improve the quality and reliability of its products, IC products have specific characteristics such as the occurrence of failure at a certain rate and malfunctions under certain use conditions. Please be sure to implement safety measures to guard against the possibility of physical injury, and injury or damage caused by fire in the event of the failure of a Renesas product, such as safety design for hardware and software including but not limited to redundancy, fire control and malfunction prevention, appropriate treatment for aging degradation or any other applicable measures. Among others, since the evaluation of microcomputer software alone is very difficult, please evaluate the safety of the final products or system manufactured by you.
11. In case Renesas products listed in this document are detached from the products to which the Renesas products are attached or affixed, the risk of accident such as swallowing by infants and small children is very high. You should implement safety measures so that Renesas products may not be easily detached from your products. Renesas shall have no liability for damages arising out of such detachment.
12. This document may not be reproduced or duplicated, in any form, in whole or in part, without prior written approval from Renesas.
13. Please contact a Renesas sales office if you have any questions regarding the information contained in this document, Renesas semiconductor products, or if you have any other inquiries.



# Contents

Section 1 Connecting the Emulator with the User System .....	1
1.1 Components of the Emulator .....	1
1.2 Connecting the E10T-USB Emulator with the User System .....	2
1.3 Pin Assignments of the E10T-USB Connector .....	4
1.4 Example of Emulator Connection.....	5
Section 2 Specification of the E10T-USB Emulator's Software .....	11
2.1 Differences between the MCUs (H8/3048F-ONE and H8/3029F) and the Emulator.....	11
2.2 The H8/3048F-ONE E10T-USB Emulator Functions .....	15
2.2.1 Emulator Driver Selection .....	15
2.2.2 Hardware Break Functions.....	15
2.2.3 Notes on Setting the [Breakpoint] Dialog Box .....	17
2.2.4 Trace Function .....	17







# Section 1 Connecting the Emulator with the User System

## 1.1 Components of the Emulator

The H8/3048F-ONE E10T-USB emulator supports the H8/3048F-ONE and H8/3029F (hereafter referred to as the MCU unless the description is specific to any of them). Table 1.1 lists the components of the emulator.

**Table 1.1 Components of the Emulator (HS0005TCU01H)**

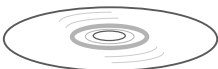
Classification	Component	Appearance	Quantity	Remarks
Hardware	Emulator box		1	HS0005TCU01H: Depth: 65.0 mm, Width: 97.0 mm, Height: 20.0 mm, Mass: 72.9 g
	User system interface cable		1	20-pin type: Length: 200 mm, Mass: 35.0 g
	USB cable		1	Length: 1500 mm, Mass: 50.6 g
Software	E10T-USB emulator setup program, H8 Family E10T-USB Emulator User's Manual, Supplementary Information on Using the H8/3048F-ONE and H8/3029F*, and Test program manual for HS0005TCU01H		1	HS0005TCU01SR,  HS0005TCU01HJ, HS0005TCU01HE,  HS3048BTCU01HJ, HS3048BTCU01HE,  HS0005TM01HJ, and HS0005TM01HE (provided on a CD-R)

Note: Additional document for the MCUs supported by the emulator is included. Check the target MCU and refer to its additional document.

## 1.2 Connecting the E10T-USB Emulator with the User System

Before connecting an E10T-USB emulator (hereafter referred to as emulator) with the user system, a connector must be installed in the user system so that a user system interface cable can be connected. When designing the user system, refer to the connector and recommended circuits shown in this manual.

Before designing the user system, be sure to read the E10T-USB emulator user's manual and the hardware manual for related MCUs.

Table 1.2 shows the recommended connector for the emulator.

**Table 1.2 Recommended Connector**

Type Number	Manufacturer	Specifications
2520-6002	3M Limited	20-pin straight type

Connect pins 2, 4, 6, 8, 10, 12, 14, and 16 of the user system connector to GND firmly on the PCB. These pins are used as electrical GND and to monitor the connection of the user system connector. Note the pin assignments of the user system connector.

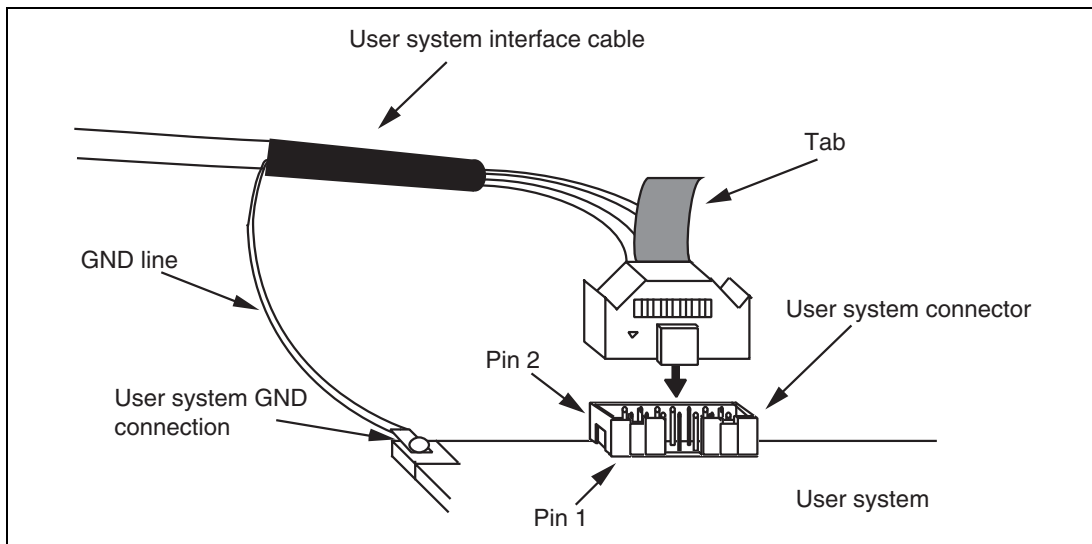

**Figure 1.1 Connecting the User System Interface Cable to the User System**

- Notes:
1. The pin number assignments of the 20-pin connector differ from those of the E10A emulator.
  2. When designing the connector layout on the user board, do not place any components within 3 mm of the connector.
  3. When the emulator is used in the writer mode, connect the emulator similarly to the user system.



## WARNING

**Be sure to place the GND line of the user system interface cable on the GND of the user system with a screw, etc. Failure to do so will result in a FIRE HAZARD due to an overcurrent and will damage the user system, the emulator product, and the host computer.**

### 1.3 Pin Assignments of the E10T-USB Connector

Figure 1.2 shows the pin assignments of the connector.

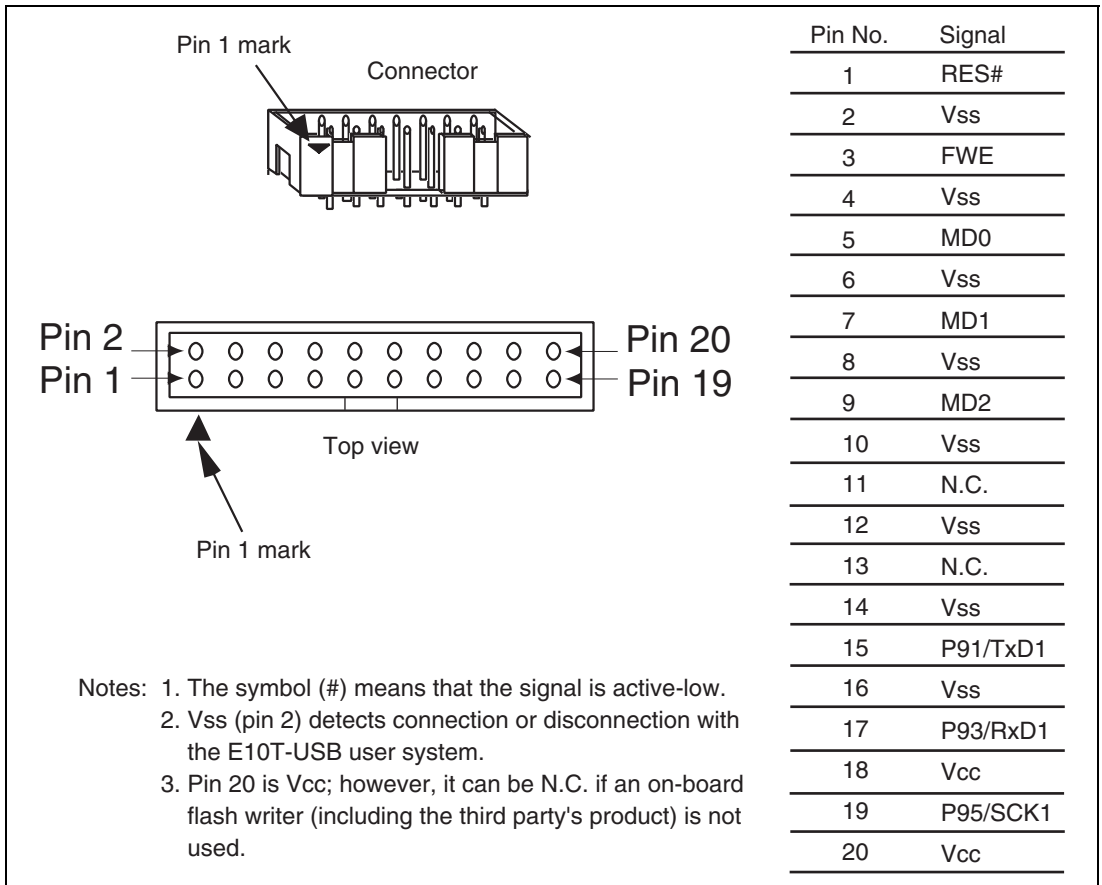

**Figure 1.2 Pin Assignments of the H-UDI Port Connector (36 Pins)**

## 1.4 Example of Emulator Connection

Figure 1.3 shows an example of emulator connection to the MCU.

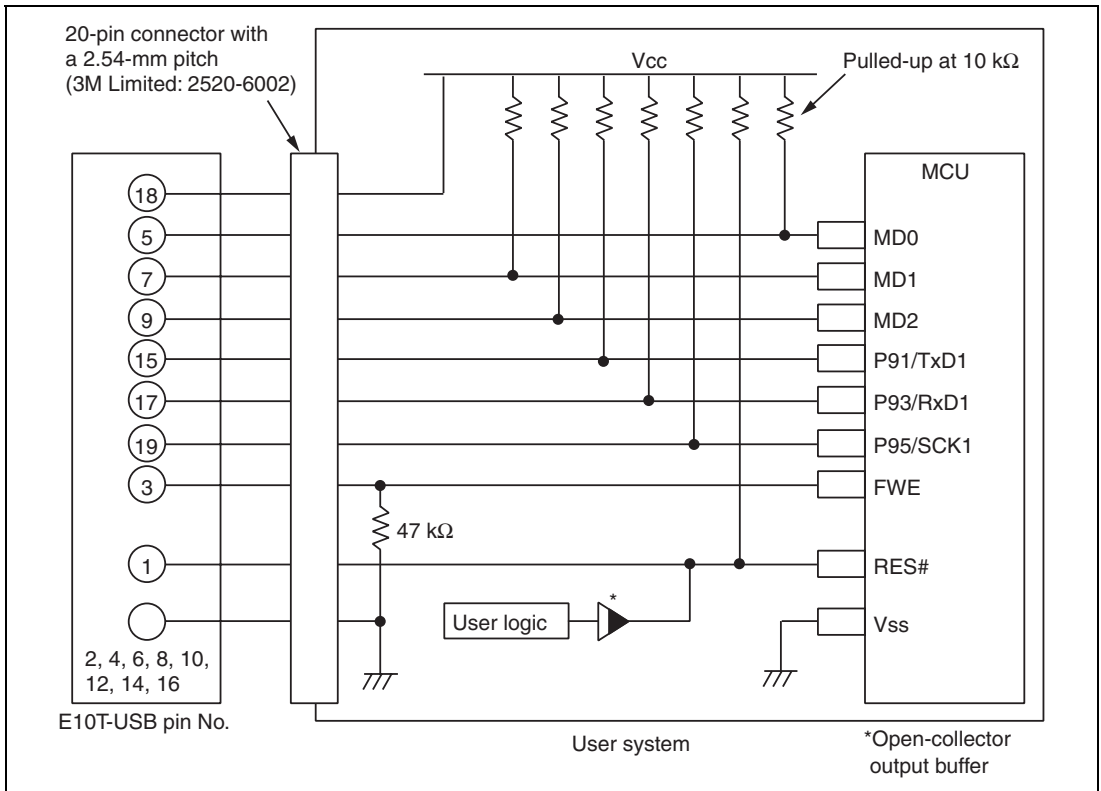

**Figure 1.3 Example of Emulator Connection (Mode 7)**

Notes: 1. P91, P93, and P95 are used by the emulator. Pull up and connect the emulator and MCU pins.

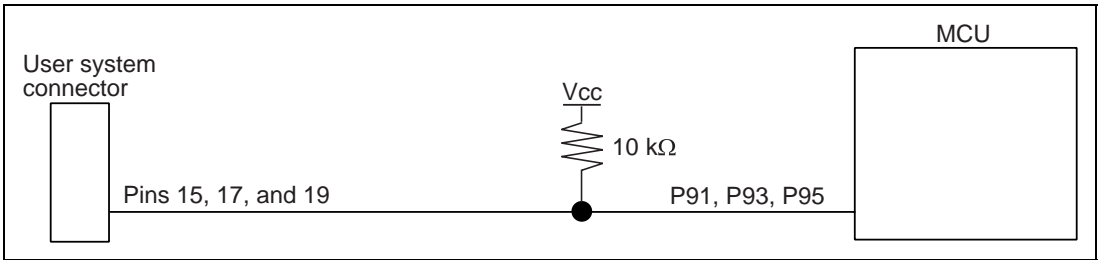

**Figure 1.4 Connection of Emulator and MCU**

2. The FWE signal is used for forced break control by the emulator. Connect the emulator and MCU pins directly.

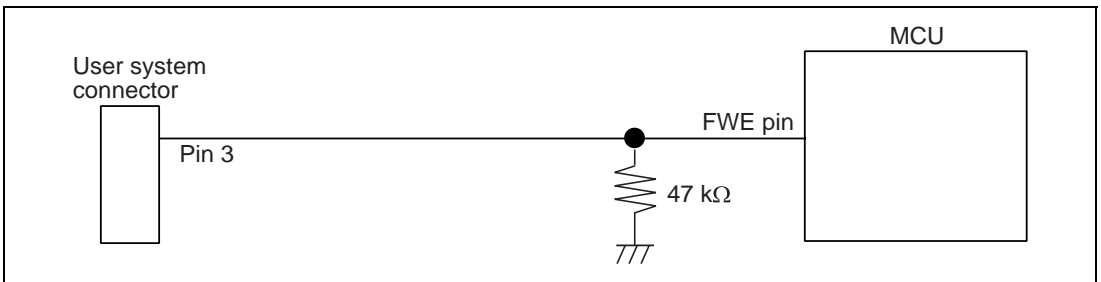

**Figure 1.5 Connection of Emulator and FWE Pin**

3. The RES# pin is used by the emulator. Create the following circuit so that a reset input from the emulator can be accepted:

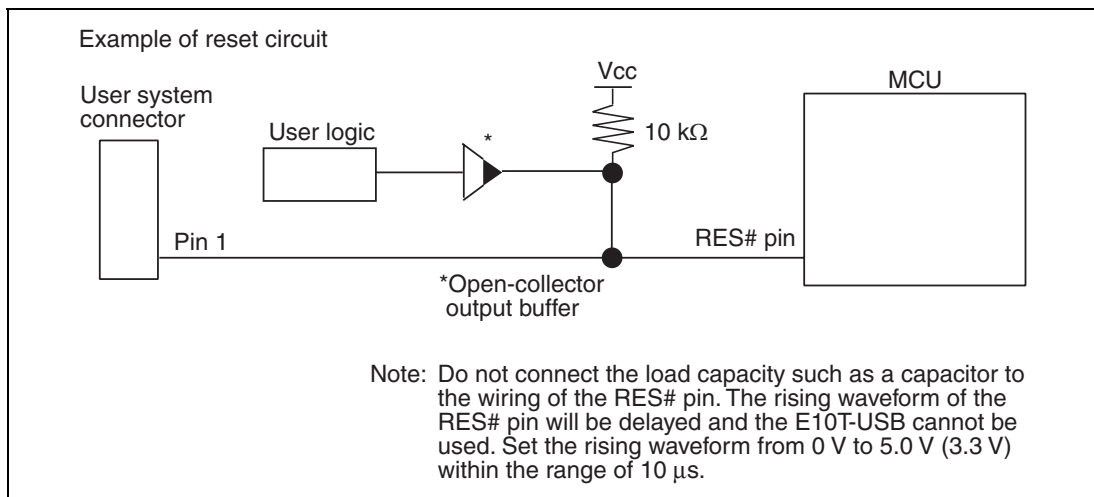

**Figure 1.6 Example of Reset Circuits**

4. MD0 to MD2 pins are used by the emulator at power-on reset. Connect MD0 to MD2 pins as shown in figure 1.7.

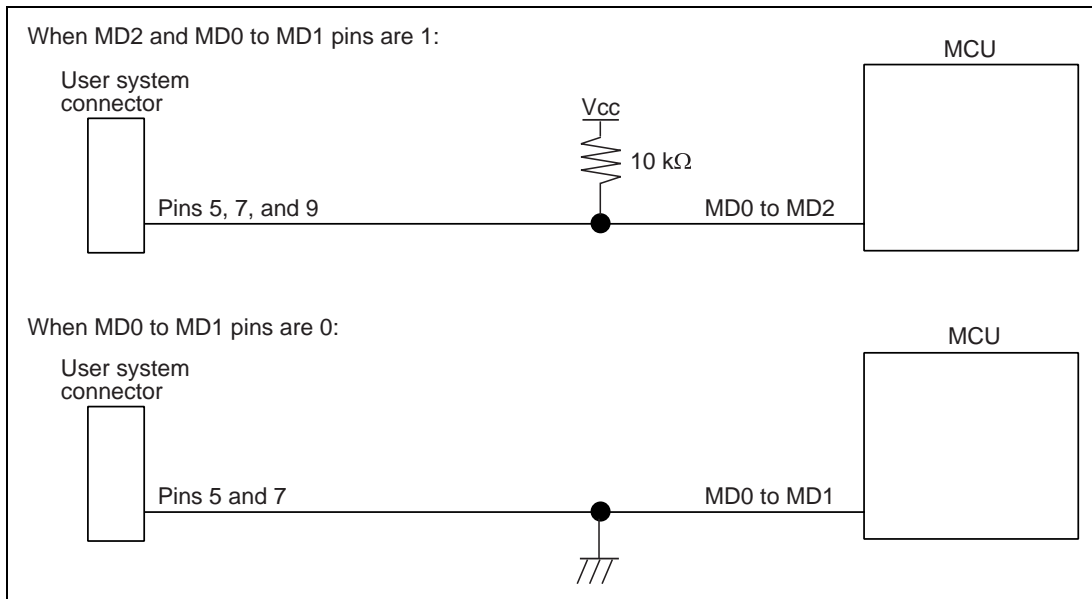

**Figure 1.7 Example of Circuits for Operating Mode Setting Pins**

5. Connect Vss and Vcc with the Vss and Vcc of the MCU, respectively.
6. Connect nothing with N.C.
7. The amount of voltage permitted to input to Vcc must be within the guaranteed range of the microcomputer. The H8/3048F-ONE has 4.5- to 5.5-V and 3.0- to 3.6-V input voltages. Use the correct input voltage depending on the microcomputer. The H8/3029F only has 3.0- to 3.6-V input voltage. Do not apply 4.5- to 5.5-V as the input to Vcc.
8. Figure 1.8 shows the interface circuit in the emulator. Use this figure as a reference to decide the pull-up resistance value.





9. When the MCU is connected to the emulator, the functions listed below cannot be used.

**Table 1.3 Pin Functions Not Available**

**H8/3048F-ONE and H8/3029F**

---

P91, P93, and P95

---

TxD1, RxD1, and SCK1

---

FWE

---

IRQ5#

---

The symbol (#) means that the signal is active-low.

## Section 2 Specification of the E10T-USB Emulator's Software

### 2.1 Differences between the MCUs (H8/3048F-ONE and H8/3029F) and the Emulator

1. The emulator supports the operating modes shown in table 2.1.

**Table 2.1 Supported Operating Mode**

MCU Name	Mode
H8/3048F-ONE	5, 6, and 7
H8/3029F	5 and 7

2. When the emulator system is initiated, it initializes the general registers and part of the control registers as shown in table 2.2. The initial value of the MCU is undefined. When the emulator is initiated from the workspace, a value to be entered is saved in a session.

**Table 2.2 Register Initial Values at Emulator Link Up**

Register	Emulator at Link Up
PC	Reset vector value in the vector address table
ER0 to ER6	Undefined
ER7 (SP)	(16-Mbyte expanded mode with on-chip ROM enabled) H8/3048F-ONE: H'FFFF10 H8/3029F: H'FFFF20 (Single-chip advanced mode) H8/3048F-ONE: H'FFF10 H8/3029F: H'FFF20 (1-Mbyte expanded mode with on-chip ROM enabled) H8/3048F-ONE: H'FFF10
CCR	1 for I mask, and others undefined

3. Low-Power Mode

During a user program break, the CPU operating frequency is forced to  $\phi$  for high-speed operation.

#### 4. Reset Signal

The MCU signals are only valid during user program execution started with clicking the GO or STEP-type button. In command input wait state, the RES signal is not sent to the H8/3048F-ONE.

Note: Do not start user program execution or access the memory while control input signal (RES) is being low. A TIMEOUT error will occur. The error will also occur when (RES) is low during a break.

#### 5. System Control Register

In the emulator, the internal I/O registers can be accessed from the [IO] window. However, be careful when accessing the system control register. The emulator saves the register value of the system control register at a break and returns the value when the user program is executed. Since this is done during a break, do not rewrite the system control register in the [IO] window.

#### 6. Memory Access during Emulation

If the memory contents are referenced or modified during emulation, realtime emulation cannot be performed because the user program is temporarily halted.

7. The emulator communicates with the H8/3048F-ONE by using the P95/SCK1, P93/RxD1, P91/TxD1, RES, FWE, and MD2 to MD0 pins. These pins cannot be used, except for RES and MD2 to MD0 pins.

8. The power consumed by the MCU can reach several mA. This is because the user power supply drives ICs to make the communication signal level match the user-system power-supply voltage.

9. The emulator uses a two-word stack pointer for values that are stored when user program execution is started or stopped (i.e., by a break). Therefore, the stack area must accept two-word addresses.

#### 10. Refresh Controller and DMA Controller

The emulator cannot debug the user program that uses the refresh controller or DMA controller.

## 11. Reading the MDCR Register and Setting the P9DDR Register in the Reset Exception Processing

Be sure to read MDCR and set P9DDR in the reset exception processing of the user program. Set bits P91DDR, P93DDR, and P95DDR in the P9DDR register as shown below.

P91DDR = 1

P93DDR = 0

P95DDR = 0

## 12. Initialization of the Internal I/O Register by Reset Function

In the [Debug] - [Reset CPU], [Debug] - [Reset GO] and RESET commands, the following internal I/O registers are not initialized. Be sure to initialize them by the user program.

[H8/3048F-ONE]

System control: SYSCR, MSTCR, DIVCR

Interrupt controller: ISCR, IER, ISR, IPRA, IPRB

Bus controller: ABWCR, ASTCR, WCR, WCER, BR CR, CSCR

Watchdog timer: TCSR, TCNT, RSTCSR

Serial communication interface (channel 1): SMR, BRR, SCR, TDR, SSR, RDR

Flash memory: FLMCR1, FLMCR2, EBR, RAMCR

D/A converter: DASTCR

[H8/3029F]

System control: SYSCR, MSTCR, DIVCR

Interrupt controller: ISCR, IER, IPRA, IPRB

Bus controller: ABWCR, ASTCR, WCRH, WCRL, BR CR

Watchdog timer: TCSR, TCNT, RSTCSR

Serial communication interface (channel 1):

SMR1, BRR1, SCR1, TDR1, SSR1, RDR1, SCMR1

Flash memory:

FPCS, FECS, FEKEY, FMATS, FTDAR, FVADRR, FVADRE, FVADRH, FVADRL

D/A converter: DASTCR

### 13. Note on Using Port 9

P91, P93, and P95 of port 9 are used by the emulator. When the P9DDR register is written in the user program, set bits P91DDR, P93DDR, and P95DDR in that register as shown below.

The P9DDR register is initialized by external reset. Be sure to set P9DDR in the reset exception processing of the user program.

P91DDR = 1

P93DDR = 0

P95DDR = 0

### 14. Sum Data Displayed in the Program Flash Mode

Sum data, which is displayed in the 'Program Flash' mode, is a value that data in the whole ROM areas has been added by bytes.

### 15. Programming Flash Memory during Debugging

The flash memory is programmed in the following functions because they use breakpoints:

- When executing [Go to cursor]
- When stepping over the subroutine
- When executing the subroutine at step-out operation

### 16. Reading Data from H8/3048F-ONE Internal Flash Memory

If the user makes the setting that allows data to be read from the internal flash memory by inputting the correct ID code and then activates the emulator, the emulator shows all data of the first address (16 bytes from H'0 to H'F) as H'FF. After activating the emulator, set the reset vector address again.

## 2.2 The H8/3048F-ONE E10T-USB Emulator Functions

- Notes:
1. Do not use an MCU that has been used for debugging.
  2. If the flash memory is rewritten many times, and the emulator is left for a few days, data may be lost due to retention problems.
  3. If the flash memory is rewritten many times, the data will not be erased. If an error message is displayed, exchange the MCU for a new one.

### 2.2.1 Emulator Driver Selection

Table 2.3 shows drivers which can be selected in the [E10T-USB Driver Details] dialog box.

**Table 2.3 Type Name and Driver**

Type Name	Driver
HS0005TCU01H	Renesas E-Series USB Driver

### 2.2.2 Hardware Break Functions

**Hardware Break Conditions:** In the emulator, conditions of Break Condition 1,2 can be set. Table 2.4 lists the items that can be specified.

**Table 2.4 Hardware Break Condition Specification Items**

Items	Description
Address bus condition	Breaks when the MCU address bus value matches the specified value.
Data bus condition	Breaks when the MCU data bus value matches the specified value. Byte or word can be specified as the access data size.
Read or write condition	Breaks in the read or write cycle.

Table 2.5 lists the combinations of conditions that can be set in the [Break condition 1] and [Break condition 2] dialog boxes.

**Table 2.5 Conditions Set in [Break condition 1] and [Break condition 2] Dialog Boxes**

Dialog Box	Condition		
	Address Bus Condition	Data Condition	Read or Write Condition
[Break condition 1]	○	○	○
[Break condition 2]	○	X	X

Note: ○: Can be set by checking the radio button in the dialog box.  
X: Cannot be set in the dialog box.

Table 2.6 lists the combinations of conditions that can be set by the BREAKCONDITION\_SET command.

**Table 2.6 Conditions Set by BREAKCONDITION\_SET Command**

Channel	Condition		
	Address Bus Condition (<addropt> option)	Data Condition (<dataopt> option)	Read or Write Condition (<r/wopt> option)
Break condition 1	○	○	○
Break condition 2	○	X	X

Note: ○: Can be set by the BREAKCONDITION\_SET command.  
X: Cannot be set by the BREAKCONDITION\_SET command.

### Notes on Setting the Break Condition:

1. When [Step In], [Step Over], or [Step Out] is selected, the settings of Break Condition are disabled.
2. Settings of Break Condition are disabled when an instruction to which a BREAKPOINT has been set is executed.
3. When step over function is used, the settings of BREAKPOINT and Break Condition are disabled.
4. Address bus conditions of Break Condition 2 and BREAKCONDITION\_SET command:  
The address bus condition of Break Condition 2 or channel 2 of the BREAKCONDITION\_SET command is satisfied only for the instruction prefetch address.  
The condition is not satisfied for the address bus value other than the instruction prefetch



address. In this case, use Break Condition 1 or channel 1 of the BREAKCONDITION\_SET command.

### 2.2.3 Notes on Setting the [Breakpoint] Dialog Box

1. When an odd address is set, the address is rounded down to an even address.
2. A BREAKPOINT is accomplished by replacing instructions. Accordingly, it can be set only to the flash memory or RAM area. However, a software break cannot be set to the following addresses:
  - An area other than flash memory or RAM
  - An instruction in which Break Condition is satisfied
3. During step operation, a BREAKPOINT is disabled.
4. A condition set at Break Condition is disabled immediately after starting execution when an instruction at a BREAKPOINT is executed. A break does not occur even if a condition of Break Condition is satisfied immediately after starting the execution.
5. When execution resumes from the breakpoint address after the program execution stops at the BREAKPOINT, single-step operation is performed at the address before execution resumes. Therefore, realtime operation cannot be performed.
6. Settings of BREAKPOINT and Break Condition are invalid while the STEP OVER function is being used.

### 2.2.4 Trace Function

The trace function in the emulator uses the branch-instruction trace function in the MCU. It displays the four-channel branch-source address, the mnemonic, and the operand. Trace can be acquired in realtime.



---

**H8 Family E10T-USB Emulator  
Additional Document for User's Manual  
Supplementary Information on Using the H8/3048F-ONE  
and H8/3029F**

Publication Date: Rev.1.00, August 27, 2004  
Rev.3.00, January 11, 2008  
Published by: Sales Strategic Planning Div.  
Renesas Technology Corp.  
Edited by: Customer Support Department  
Global Strategic Communication Div.  
Renesas Solutions Corp.

Renesas Technology Corp. Sales Strategic Planning Div. Nippon Bldg., 2-6-2, Ohte-machi, Chiyoda-ku, Tokyo 100-0004, Japan

---



## RENESAS SALES OFFICES

<http://www.renesas.com>

Refer to "<http://www.renesas.com/en/network>" for the latest and detailed information.

### **Renesas Technology America, Inc.**

450 Holger Way, San Jose, CA 95134-1368, U.S.A  
Tel: <1> (408) 382-7500, Fax: <1> (408) 382-7501

### **Renesas Technology Europe Limited**

Dukes Meadow, Millboard Road, Bourne End, Buckinghamshire, SL8 5FH, U.K.  
Tel: <44> (1628) 585-100, Fax: <44> (1628) 585-900

### **Renesas Technology (Shanghai) Co., Ltd.**

Unit 204, 205, AZIACenter, No.1233 Lujiazui Ring Rd, Pudong District, Shanghai, China 200120  
Tel: <86> (21) 5877-1818, Fax: <86> (21) 6887-7858/7898

### **Renesas Technology Hong Kong Ltd.**

7th Floor, North Tower, World Finance Centre, Harbour City, Canton Road, Tsimshatsui, Kowloon, Hong Kong  
Tel: <852> 2265-6688, Fax: <852> 2377-3473

### **Renesas Technology Taiwan Co., Ltd.**

10th Floor, No.99, Fushing North Road, Taipei, Taiwan  
Tel: <886> (2) 2715-2888, Fax: <886> (2) 3518-3399

### **Renesas Technology Singapore Pte. Ltd.**

1 Harbour Front Avenue, #06-10, Keppel Bay Tower, Singapore 098632  
Tel: <65> 6213-0200, Fax: <65> 6278-8001

### **Renesas Technology Korea Co., Ltd.**

Kukje Center Bldg. 18th Fl., 191, 2-ka, Hangang-ro, Yongsan-ku, Seoul 140-702, Korea  
Tel: <82> (2) 796-3115, Fax: <82> (2) 796-2145

### **Renesas Technology Malaysia Sdn. Bhd**

Unit 906, Block B, Menara Amcorp, Amcorp Trade Centre, No.18, Jln Persiaran Barat, 46050 Petaling Jaya, Selangor Darul Ehsan, Malaysia  
Tel: <603> 7955-9390, Fax: <603> 7955-9510



**H8 Family E10T-USB Emulator  
Additional Document for User's Manual  
Supplementary Information on Using  
the H8/3048F-ONE and H8/3029F**



**Renesas Electronics Corporation**

1753, Shimonumabe, Nakahara-ku, Kawasaki-shi, Kanagawa 211-8668 Japan

REJ10J1202-0300