

ISL28005xEVAL1Z

The ISL28005 evaluation board is a design platform containing all the circuitry needed to characterize critical performance parameters of the ISL28005 in either a high side or low-side current sense application. The ISL28005 is available in fixed 100V/V, 50V/V, and 20V/V gains.

Features

- One installed sense resistor: 100mΩ, 1W, 1%
- Connectors for direct connections to external system supply and load resistor
- Options for four more on-board sense resistors
- Options for additional input and output filter resistors and capacitors

Specifications

- Low Power Consumption: 50μA, Typ
- Supply Range on VS+: 2.7V to 28V
- Wide Common Mode Input: 0V to 28V
- Operating Temperature Range: -40°C to +125°C

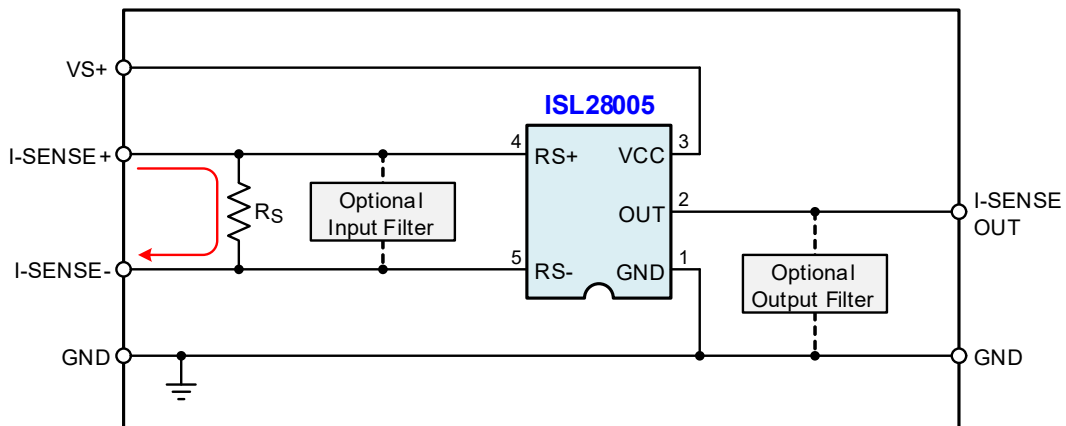

Figure 1. Block Diagram

Contents

1. Functional Description	3
1.1 Optional Transient Protection	3
1.2 Power Supplies	3
2. Board Design	4
2.1 Schematic Diagram	5
2.2 Bill of Materials	6
2.3 Board Layout	6
3. Ordering Information	7
4. Revision History	7

1. Functional Description

1.1 Optional Transient Protection

For applications where the load and the power source are permanently connected, transient protection is not required and only an external current sense resistor (R_3) is needed.

For applications where fast transients can generate voltage spikes that can overdrive the amplifier input and drive the output of the amplifier into the rails, resulting in a long overload recovery time. Common mode capacitors C_7 , C_9 and differential capacitor C_8 are used to filter the common mode and differential voltage spikes.

For switching applications or where fast transients are caused by hot plugging the source or load, external protection components may be needed. The external current limiting resistor (R_6) in [Figure 4](#) limits the peak current through the internal ESD diodes to <20mA. This condition can occur in applications that experience high levels of in-rush current causing high peak voltages that can damage the internal ESD diodes of the ISL28005. If the current limiting resistor is required, it needs to be placed on the RS- input (R_6). Placing it on the RS+ input side (R_7) will result in a much larger error voltage due to the ISL28005 taking its supply current from the sense current in high-side applications.

For example:

Current limiting resistor R_6 with a value of 100Ω provides protection for a 2V transient with the maximum of 20mA flowing through the input while adding only an additional $13\mu\text{V}$ (worst case over-temperature) of V_{OS} as shown in [Equation 1](#). **Note:** Worst case over-temperature input bias current on the RS- input is 130nA.

$$\text{(EQ. 1)} \quad R_6 \times I_{RS-} = 100\Omega \times 130\text{nA} = 13\mu\text{V}$$

Current limiting resistor R_7 with value of 100Ω provides the same transient protection, but with an error voltage of $800\mu\text{V}$. **Note:** Worst case over-temperature input bias current on the RS+ input is $8\mu\text{A}$ as shown in [Equation 2](#).

$$\text{(EQ. 2)} \quad R_7 \times I_{RS+} = 100\Omega \times 8\mu\text{A} = 800\mu\text{V}$$

R_7 is a carry-over from our characterization board and was used to measure input bias current. The evaluation board is populated with a 0Ω resistor for R_7 .

1.2 Power Supplies

External power connections are made through the VS+ and Ground connections on the evaluation board. Capacitors C_2 and C_4 perform two duties, de-coupling the supplies and with R_{15} , filtering of the power supply noise. Anti-reverse diodes D_1 and D_3 protect the circuit in the case of accidental polarity reversal of the supply. Resistor R_{12} is used to connect ground to the fixed gain parts.

2. Board Design

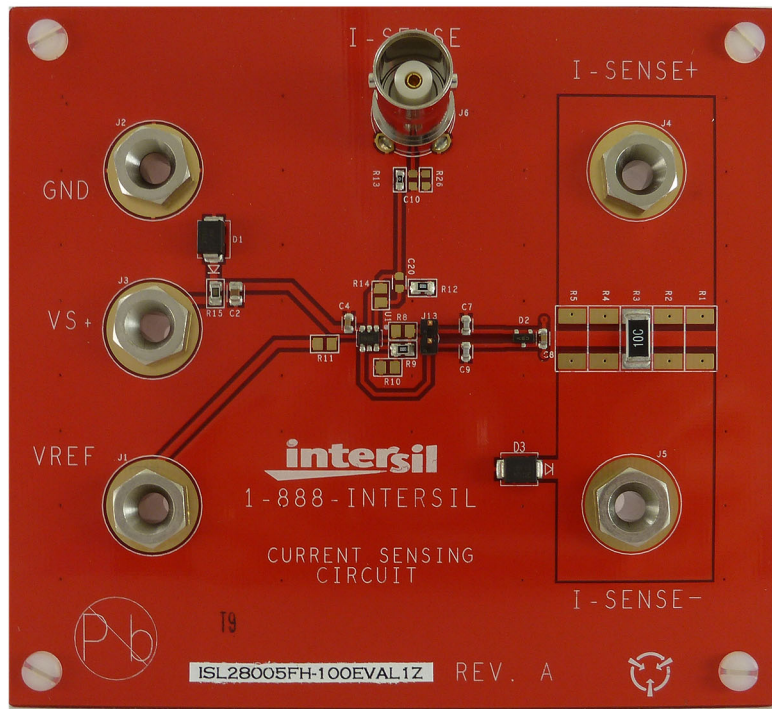

Figure 2. ISL28005FH-100EVAL1Z Evaluation Board (Top)

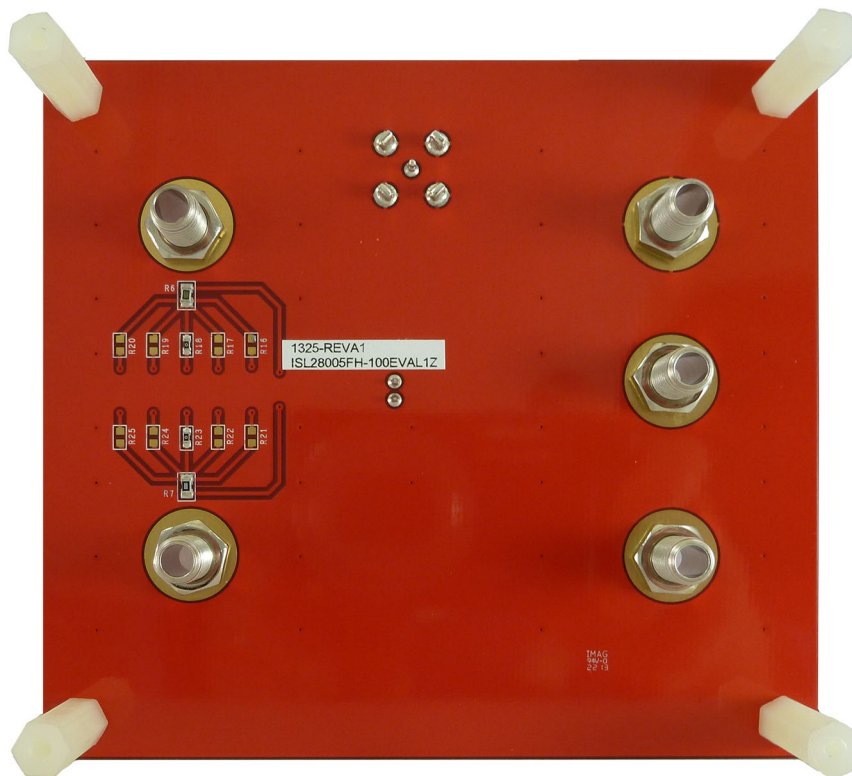

Figure 3. ISL28005FH-100EVAL1Z Evaluation Board (Bottom)

2.1 Schematic Diagram

The ISL2800XEVAL1Z evaluation board is configured with either the ISL28005-100, ISL28005-50, or ISL28005-20 device.

Figure 1 shows the basic application circuit and optional protection components for the fixed gain parts. Figure 4 shows the complete schematic for the ISL2800XEVAL1Z evaluation board.

Components shown in red in Figure 4 are optional transient protection and not required for clean environments.

Note: The evaluation board comes equipped with the transient protection devices.

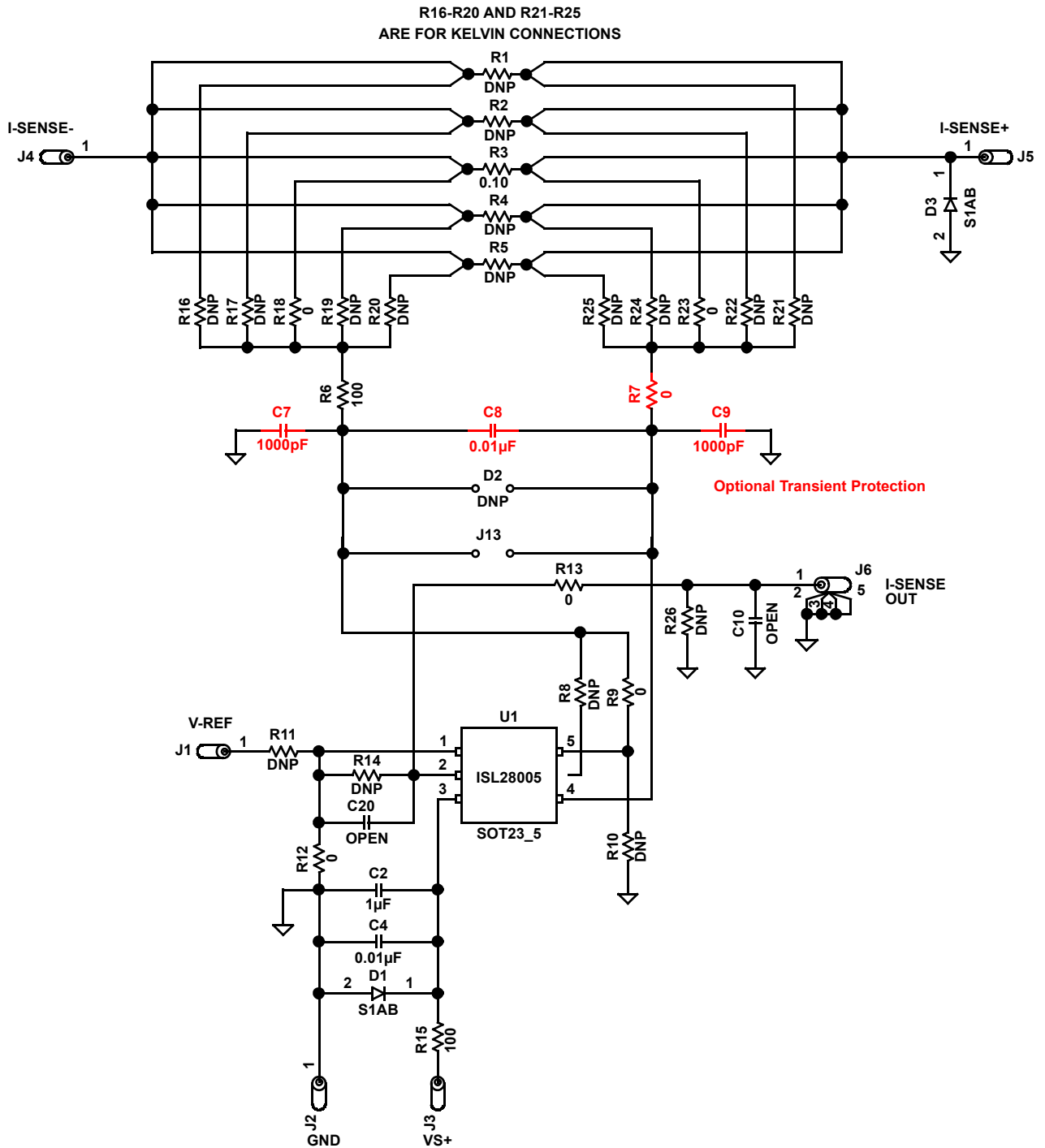

Figure 4. ISL28005xEVAL1Z Schematic Diagram

2.2 Bill of Materials

Reference Designator	Description	Comments
C2	CAP, SMD, 0805, 1 μ F, 50V, 20%, X7R, ROHS	Power Supply Decoupling and Input Filter
C4, C8	CAP, SMD, 0603, 0.01 μ F, 50V, 10%, X7R, ROHS	Power Supply Decoupling/Input Filter and Differential Current Sense Filter
C7, C9	CAP, SMD, 0603, 1000pF, 50V, 10%, X7R, ROHS	Common Mode Current Sense Filter
C10, C20	CAP, SMD, 0603, DNP - Place Holder, ROHS	User Selectable Capacitors - Not Populated
D1, D3	Diode-Rectifier, SMD, S1AB, 50V, ROHS	Reverse Power Protection
U1	ISL28005FH100Z-T7, SOT-23, ROHS	For ISL28005-100EVAL1Z board only
	ISL28005FH50Z-T7, SOT-23, ROHS	For ISL28005-50EVAL1Z board only
	ISL28005FH20Z-T7, SOT-23, ROHS	For ISL28005-20EVAL1Z board only
R16, R17, R19 -R22, R24, R25	Resistor, SMD, 0603, MF, DNP - Place Holder	User Selectable Kelvin Connection - Not Populated
R26	Resistor, SMD, 0603, MF, DNP - Place Holder	User Selectable Output Load Resistor - Not Populated
R3	Resistor, SMD, 2512, 0.1 Ω , 1W, 1%, TF, ROHS	Sense Resistor
R1, R2, R4, R5	Resistor, SMD, 2512, DNP - Place Holder	User Selectable Sense Resistors - Not Populated
R6, R7, R13, R18, R23	Resistor, SMD, 0603, 0 Ω , 1/10W, TF, ROHS	Zero Ohm User Selectable Resistors
R15	Resistor, SMD, 0603, 100 Ω , 1/10W, TF, ROHS	Current Limiting Resistors

2.3 Board Layout

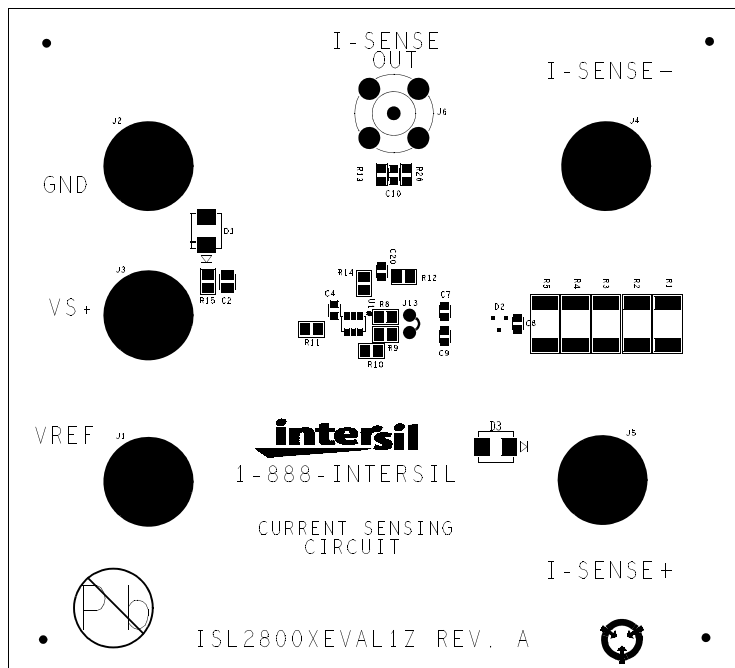

Figure 5. Top Layer

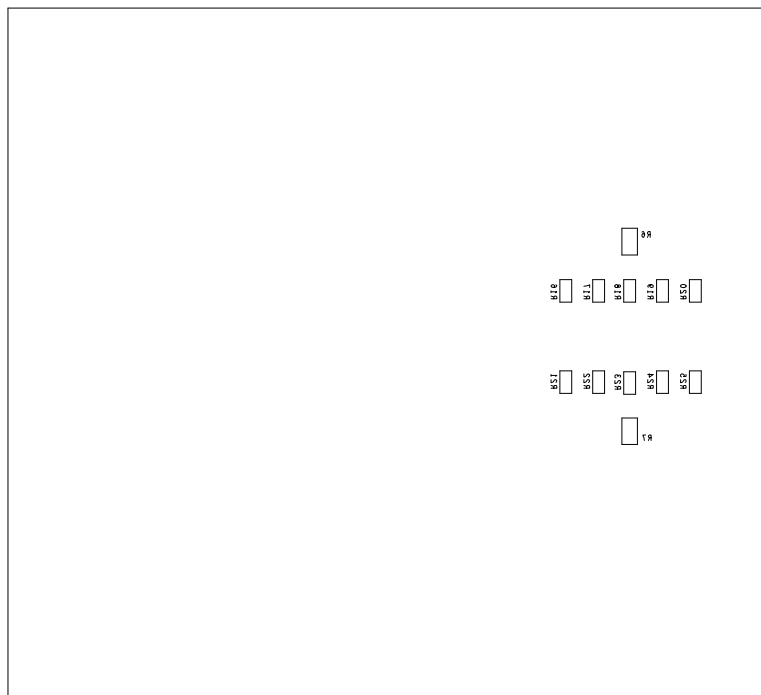

Figure 6. Bottom Layer

3. Ordering Information

Part Number	Description
ISL28005-100EVAL1Z	ISL28005 100V/V fixed gain evaluation board
ISL28005-50EVAL1Z	ISL28005 50V/V fixed gain evaluation board
ISL28005-20EVAL1Z	ISL28005 20V/V fixed gain evaluation board

4. Revision History

Revision	Date	Description
1.00	Feb 9, 2022	Applied new template. Updated Figure 1. Added Figures 2, 3, and 6. Added Ordering Information Tale.
0.00	Feb 18, 2010	Initial release

IMPORTANT NOTICE AND DISCLAIMER

RENESAS ELECTRONICS CORPORATION AND ITS SUBSIDIARIES (“RENESAS”) PROVIDES TECHNICAL SPECIFICATIONS AND RELIABILITY DATA (INCLUDING DATASHEETS), DESIGN RESOURCES (INCLUDING REFERENCE DESIGNS), APPLICATION OR OTHER DESIGN ADVICE, WEB TOOLS, SAFETY INFORMATION, AND OTHER RESOURCES “AS IS” AND WITH ALL FAULTS, AND DISCLAIMS ALL WARRANTIES, EXPRESS OR IMPLIED, INCLUDING, WITHOUT LIMITATION, ANY IMPLIED WARRANTIES OF MERCHANTABILITY, FITNESS FOR A PARTICULAR PURPOSE, OR NON-INFRINGEMENT OF THIRD PARTY INTELLECTUAL PROPERTY RIGHTS.

These resources are intended for developers skilled in the art designing with Renesas products. You are solely responsible for (1) selecting the appropriate products for your application, (2) designing, validating, and testing your application, and (3) ensuring your application meets applicable standards, and any other safety, security, or other requirements. These resources are subject to change without notice. Renesas grants you permission to use these resources only for development of an application that uses Renesas products. Other reproduction or use of these resources is strictly prohibited. No license is granted to any other Renesas intellectual property or to any third party intellectual property. Renesas disclaims responsibility for, and you will fully indemnify Renesas and its representatives against, any claims, damages, costs, losses, or liabilities arising out of your use of these resources. Renesas' products are provided only subject to Renesas' Terms and Conditions of Sale or other applicable terms agreed to in writing. No use of any Renesas resources expands or otherwise alters any applicable warranties or warranty disclaimers for these products.

(Rev.1.0 Mar 2020)

Corporate Headquarters

TOYOSU FORESIA, 3-2-24 Toyosu,
Koto-ku, Tokyo 135-0061, Japan
www.renesas.com

Contact Information

For further information on a product, technology, the most up-to-date version of a document, or your nearest sales office, please visit:
www.renesas.com/contact/

Trademarks

Renesas and the Renesas logo are trademarks of Renesas Electronics Corporation. All trademarks and registered trademarks are the property of their respective owners.