

ISL59482EVAL1Z

Evaluation Board User Guide

AN1282
Rev 0.00
January 10, 2007

Introduction

The ISL5948x EVAL1Z evaluation board contains the ISL59482 Dual 4:1 RGB MUX amp and associated components needed to implement an 8:1 RGB+H/V sync video multiplexer. The 8 video input ports, and single output port are accessed using standard 15 pin VGA female connectors. The I/O connectors are compatible with most VGA, SVGA and XGA video sources and video monitors with VGA cable interfaces. A typical application would use the ISL5948x EVAL1Z board to multiplex anywhere from 2 to 8 PC's or laptops to a single video monitor or projector.

Evaluation Board Description and Key Features

The multiplexing of the RGB video is performed by the ISL59482. Multiplexing the H and V sync signals is accomplished using two ISL84051 8:1 analog switches. The ISL59482 Video MUX and the analog H and V sync multiplexers have the same input channel select logic coding, and are parallel-connected to form a single 3 input binary coded interface (S0, S1, S2). An additional ISL84051 8:1 analog switch and channel-select LED indicators are included to identify the selected input channel. The evaluation board contains three different channel select options via jumpers on the board. Switches on the board enable direct logic control in binary format. The on-board oscillator and 4-bit counter can be connected to provide a

continuous channel-by-channel scan of as few as 2 input channels up to all 8 (Table 2). A jumper option allows the user to disconnect the auto-scan oscillator and use the on-board momentary-contact switch to manually scan through the selected channels.

Reference Documents

- ISL59482 Data Sheet, FN6209

Getting Started

The evaluation board should have the same appearance as the silk screen shown in Figure 1. Prior to applying power, connect the source input VGA cables and the evaluation board output VGA cable to the respective video components. The evaluation board, as supplied, is designed for 75Ω source impedances and requires a 75Ω termination impedance in the output display device.

Applying Power to the Evaluation Board

The following safeguards will ensure correct power-up.

1. Limit the current on ±5V supplies to 250mA.
2. Turn on the power supplies after the power cables are attached to the evaluation board.

Power supply protection Schottky diodes are included on the ±5V supplies to prevent damage due to reverse polarity.

Evaluation Board Jumper, Cable Header, and Switch Descriptions

COMPONENT	DESCRIPTION
JUMPERS	
J1	Selects channel select via single-step momentary contact switch S4, or auto mode using on-board oscillator
J-S0	Selects S0 logic input to manual control via switch S0 or through external control ribbon cable header
J-S1	Selects S1 logic input to manual control via switch S1 or through external control ribbon cable header
J-S2	Selects S2 logic input to manual control via switch S2 or through external control ribbon cable header
HEADERS	
EN	External MUX enable: Internal pull-down (logic 0) enables RGB+H/V output, logic high disables RGB and H/V sync output
S0	External S0 channel select logic input
S1	External S1 channel select logic input
S2	External S2 channel select logic input
SWITCHES	
S0	Manual channel select logic input S0
S1	Manual channel select logic input S1
S2	Manual channel select logic input S2
S3	Momentary contact channel select step control

FIGURE 1. ISL5948xEVAL1Z TOP VIEW

Testing the Evaluation Board

Testing the video and sync signal paths is accomplished using 1 or more RGB+H/V test video sources and a video monitor as the measurement device. Before powering the board, connect the jumpers as follows:

1. Connect jumpers J-S0, J-S1 and J-S2 to the MANUAL position (center to right post).
2. Connect jumper J1 to the single-step position (center to left post).

The following tests should be performed in the order shown.

Power Supply Tests

1. Connect an ammeter in series with the +5V and -5V supply.
2. Connect power supplies to the respective +5V, -5V and ground banana jacks.
3. Set supplies to +5V; $\pm 50\text{mV}$ and -5V; $\pm 50\text{mV}$. Supply power to the board.
4. Measure +5V supply current = $+110\text{mA} \pm 20\text{mA}$
5. Measure -5V supply current = $-100\text{mA} \pm 20\text{mA}$

Channel Select Logic and Video Performance Test

1. Calibrate the video test source with the video monitor by connecting the source(s) to the video monitor and selecting a display suitable for verifying correct luminance, display resolution and H/V sync lock. The test display in the following evaluation board tests should be identical to the test display.
2. Re-connect the video monitor to the VIDEO_OUT VGA connector on the evaluation board.
3. Connect the video test source to IN0. Additional video sources can speed up the verification process. If more than 1 test source is available connect each in sequential fashion to IN1, IN2 etc.
4. Set switches S0, S1 and S2 to the GND position and apply power.
5. After $\sim 3\text{s}$ the test display supplied to IN0 should appear on the test monitor exactly as it appeared in step 1.

NOTE: The $\sim 3\text{s}$ delay is a built in delay common in many display devices to lock onto the H/V sync signals and adjust the picture prior to enabling the display screen.

6. Perform the display test on the remaining video inputs by moving the video input source to the appropriate input according to the truth table in Table 1.
7. Signal calibration can also be performed using the RGB BNC connectors J6, J7 and J8 to connect an external signal into IN7 input, while monitoring the RGB outputs using BNCs J3, J4 and J5. To connect the BNCs, the open resistor placements R76 through R81 must be populated with 0Ω resistors.

Auto-Scan Test

1. Connect scope probe to the J1 AUTO pin and observe a logic level (0 to +5V) square wave with $\sim 3\text{s}$ period.
2. Connect jumpers J-S0, J-S1, and J-S2 to the AUTO position (center to left post).
3. Connect jumper J1 to the AUTO position and observe that the display scans all the test sources connected to the input channels (center to right post).
4. Connect jumper J1 to the single-step position and use the momentary contact switch S4 to manually all the test sources.

Test completed.

RGB Video Signal Path

The video inputs are terminated with 75Ω resulting in an overall RGB video path gain of 1 when using 75Ω video source impedance and load terminations (Figure 2). The RGB outputs contain series-connected 75Ω back-termination resistors for cable driving. The ISL59482 operates with a gain of +2. Provision for additional gain is provided by triple op amp U6 (EL5364 - not populated), gain resistors R62, R63, R67, and R71 thru R73. The 0Ω resistors R68, thru R70 must be removed when using the triple op amp. Gain reduction is best achieved when using the divider network R_S and R_t . Capacitor pads (C_{np}) are provided to adjust the frequency response of the amplifier.

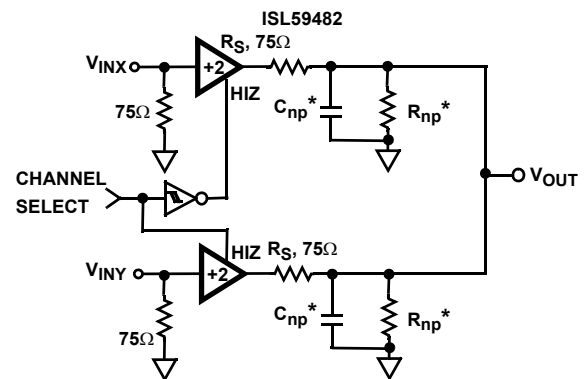

* C_{NP} AND R_{NP} ARE NOT POPULATED AND ARE PROVIDED FOR FREQUENCY RESPONSE ADJUSTMENT

FIGURE 2. VIDEO SIGNAL PATH

Channel Select Logic

The ISL59482 RGB MUX and the H/V sync MUX share the same 1 of 8 input channel select logic inputs (S0, S1, S2). The channel select logic is shown in Table 1. Three methods of channel select logic control are provided using jumpers.

TABLE 1. CHANNEL SELECT TRUTH TABLE

S2	S1	S0	VIDEO OUT
0	0	0	IN0
0	0	1	IN1
0	1	0	IN2
0	1	1	IN3
1	0	0	IN4
1	0	1	IN5
1	1	0	IN6
1	1	1	IN7

Auto Sequencing Using the On-Board Oscillator

An on-board 0.3Hz R-C oscillator (Figure 3) drives the master clock of the 4-bit binary counter, which generates the channel select logic inputs S0, S1 and S2. The default 6s channel scan rate provides the time needed by the display to sync-lock and adjust the picture prior to enabling the display. The 2.2M Ω (R1) resistor value can be reduced to speed up the channel scan time. Jumper J1 is provided to select either the 6s auto-step timer, or the momentary contact switch for manual stepping.

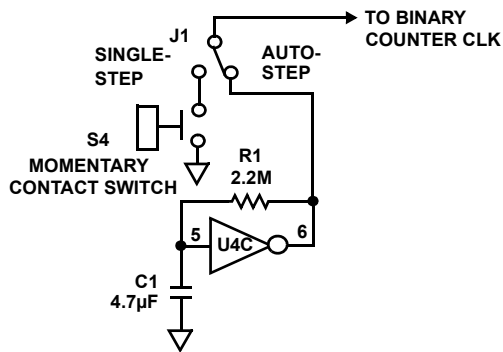

FIGURE 3. CHANNEL SCAN OSCILLATOR

Internal and External Channel Select Logic

J-S0, J-S1 and J-S2 are two-position jumpers that control the method of channel selection. In the AUTO position, the internal channel scan is enabled. The MANUAL position connects the on-board SPDT switches (S0, S1, and S2) for manual selection. A parallel-connected EXTERNAL CONTROL ribbon cable header is provided for external channel select control.

A wide range of auto-scan options can be selected by connecting only 1 or 2 of the 3 jumpers to the internal logic, with the remainder connected to the switch. For example, connecting jumper J-S0 to the AUTO position and connecting jumpers J-S1 and J-S2 to the MANUAL position with the switches S1 and S2 to the logic 0 state limits the channel scan to only 2 of the 8 channels (IN0 and IN1). Moving a second jumper from the MANUAL position to the AUTO position, increases the number of channels scanned from 2 to 4. The complete list of channel scan jumper options are shown in Table 2.

TABLE 2. CHANNEL SCAN SELECT LOGIC TABLE

CHANNELS SCANNED	JUMPER POSITION			SWITCH POSITION			CHANNELS SELECTED							
	J-S2	J-S1	J-S0	S2	S1	S0	IN0	IN1	IN2	IN3	IN4	IN5	IN6	IN7
8	Auto	Auto	Auto	-	-	-	X	X	X	X	X	X	X	X
4	Manual	Auto	Auto	0	-	-	X	X	X	X				
	Manual	Auto	Auto	1	-	-					X	X	X	X
	Auto	Manual	Auto	-	0	-	X	X			X	X		
	Auto	Manual	Auto	-	1	-			X	X			X	X
	Auto	Auto	Manual	-	-	0	X		X		X		X	
	Auto	Auto	Manual	-	-	1		X		X		X		X
2	Manual	Manual	Auto	0	0	-	X	X						
	Manual	Manual	Auto	0	1	-			X	X				
	Manual	Manual	Auto	1	0	-					X	X		
	Manual	Manual	Auto	1	1	-							X	X
	Auto	Manual	Manual	-	0	0	X				X			
	Auto	Manual	Manual	-	0	1		X				X		
	Auto	Manual	Manual	-	1	0			X				X	
	Auto	Manual	Manual	-	1	1				X				X
	Manual	Auto	Manual	0	-	0	X		X					
	Manual	Auto	Manual	0	-	1					X		X	
	Manual	Auto	Manual	1	-	0		X		X				
	Manual	Auto	Manual	1	-	1						X		X

ISL5948xEVAL1Z Schematic Diagram

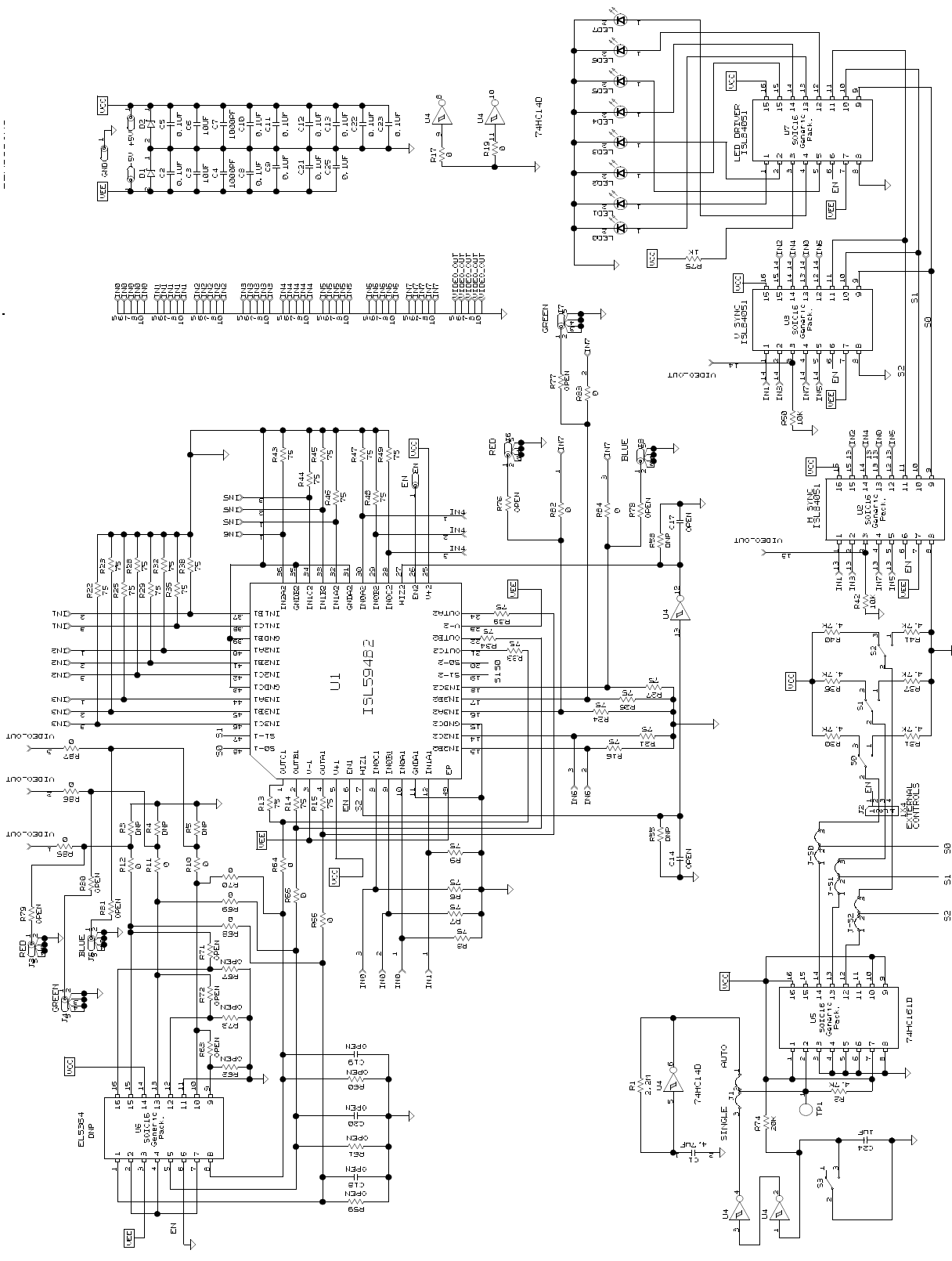

ISL5948xEVAL1Z Components List

COMPONENT	P/N, VALUE	MANUFACTURER	RATING
PWB	ISL5948xEVAL1Z REV A PCB, ROHS	Intersil Corp.	N/A
U ₁ - 8:1 RGB Video MUX	ISL59482IRZA QFN48 Pb-Free	Intersil Corp.	N/A
U ₂ , U ₃ , U ₇ - 8:1 Analog MUX	ISL84051IBZ SOIC16 Pb-Free	Intersil Corp.	N/A
U ₄ - Hex Inverter	SN74HC14D SOIC14	TI	N/A
U ₅ - 4-Bit Binary Counter	SN74HC161D SOIC16	TI	N/A
U ₆ - Triple 600MHz Op Amp	EL5364ISZ SOIC16 Pb-Free	Intersil Corp.	DNP
C4, C7	CAP, SMD, 0603 1000pF	10%, X7R	25V
C2, C5, C8-C13, C21, C23, C25	CAPACITOR, SMD, 0603, 0.1μF	N/A	25V
C3, C6	CAPACITOR, SMD, 0805, 10μF	10%, X5R	6.3V
C1	CAPACITOR, SMD, 0805, 4.7μF	10%, X5R	16V
C14, C17-C20	CAPACITOR, SMD, 0805, DNP	N/A	DNP
IN0 TO IN7, VIDEO_OUT	181-015-213R171 CONN-SUB MINI D, 15PIN, RECEPTACLE, RT ANGLE, FRONT METAL SHELL	NORCOMP	N/A
+5V, -5V, EN, GND	CONN-JACK, BANA-SS-SDRLESS, VERTIC	N/A	N/A
J2	CONN-HEADER, 4PIN, BRKAWY, 2.54mm, VERT	J2	
J-S0, J-S1, J-S2, J1	CONN-HEADER, 1x3, BRKAWY 1x36, 0.1	N/A	N/A
D1, D2	MBR0540T1-T DIODE-RECTIFIER, SMD SOD-123, 2PIN	SEMICON	40V, 0.5A
LED0 - LED7	597-3111-407F LED, SMD, 1206, RED, 30mA, 60mW, 17mcd, ROHS	DIALIGHT	N/A
R76 - R81	RESISTOR, SMD, 0603, 0Ω, DNP		DNP
R3-R5, R55-58	RESISTOR, SMD, 0805, DNP, DNP, DNP, TF	N/A	DNP
R10-R12, R82-R87	RESISTOR, SMD, 0603, 0Ω	N/A	N/A
R62, R67, R73	RESISTOR, SMD, 0603, 432Ω DNP	1%	DNP
R63, R71, R72	RESISTOR, SMD, 0603, 562Ω D	1%	DNP
R6-R9, R13-R16, R21-R29, R32-R35, R39, R43-R49	RESISTOR, SMD, 0805, 75Ω	1%	1/10W
R13-R15, R17-R20, R33, R34, R39, R68-R70	RESISTOR, SMD, 0805, 0Ω	N/A	1/10W
R42, R50	RESISTOR, SMD, 0805, 10k	5%	1/10W
R74	RESISTOR, SMD, 0805, 20kΩ,	5%	1/10W
R1	RESISTOR, SMD, 0805, 2.2M	5%	1/8W
R2, R30, R31, R36, R37, R40, R41	RESISTOR, SMD, 0805, 4.7k	5%	1/10W
R59-R61	RESISTOR, DNP, SMD, 0805, 499, DNP	5%	DNP
R75	RESISTOR, SMD, 0603, 1kΩ	5%	1/10W
S0-S2	SWITCH-TOGGLE, THRU, SPDT, 5P, ON-N	N/A	N/A
S3	SWITCH-PUSHBUTTON, TH, 6mm, 4P, ON/OFF,	N/A	12V, 0.05A

Notice

1. Descriptions of circuits, software and other related information in this document are provided only to illustrate the operation of semiconductor products and application examples. You are fully responsible for the incorporation or any other use of the circuits, software, and information in the design of your product or system. Renesas Electronics disclaims any and all liability for any losses and damages incurred by you or third parties arising from the use of these circuits, software, or information.
2. Renesas Electronics hereby expressly disclaims any warranties against and liability for infringement or any other claims involving patents, copyrights, or other intellectual property rights of third parties, by or arising from the use of Renesas Electronics products or technical information described in this document, including but not limited to, the product data, drawings, charts, programs, algorithms, and application examples.
3. No license, express, implied or otherwise, is granted hereby under any patents, copyrights or other intellectual property rights of Renesas Electronics or others.
4. You shall not alter, modify, copy, or reverse engineer any Renesas Electronics product, whether in whole or in part. Renesas Electronics disclaims any and all liability for any losses or damages incurred by you or third parties arising from such alteration, modification, copying or reverse engineering.
5. Renesas Electronics products are classified according to the following two quality grades: "Standard" and "High Quality". The intended applications for each Renesas Electronics product depends on the product's quality grade, as indicated below.
"Standard": Computers; office equipment; communications equipment; test and measurement equipment; audio and visual equipment; home electronic appliances; machine tools; personal electronic equipment; industrial robots; etc.
"High Quality": Transportation equipment (automobiles, trains, ships, etc.); traffic control (traffic lights); large-scale communication equipment; key financial terminal systems; safety control equipment; etc.
Unless expressly designated as a high reliability product or a product for harsh environments in a Renesas Electronics data sheet or other Renesas Electronics document, Renesas Electronics products are not intended or authorized for use in products or systems that may pose a direct threat to human life or bodily injury (artificial life support devices or systems; surgical implantations; etc.), or may cause serious property damage (space system; undersea repeaters; nuclear power control systems; aircraft control systems; key plant systems; military equipment; etc.). Renesas Electronics disclaims any and all liability for any damages or losses incurred by you or any third parties arising from the use of any Renesas Electronics product that is inconsistent with any Renesas Electronics data sheet, user's manual or other Renesas Electronics document.
6. When using Renesas Electronics products, refer to the latest product information (data sheets, user's manuals, application notes, "General Notes for Handling and Using Semiconductor Devices" in the reliability handbook, etc.), and ensure that usage conditions are within the ranges specified by Renesas Electronics with respect to maximum ratings, operating power supply voltage range, heat dissipation characteristics, installation, etc. Renesas Electronics disclaims any and all liability for any malfunctions, failure or accident arising out of the use of Renesas Electronics products outside of such specified ranges.
7. Although Renesas Electronics endeavors to improve the quality and reliability of Renesas Electronics products, semiconductor products have specific characteristics, such as the occurrence of failure at a certain rate and malfunctions under certain use conditions. Unless designated as a high reliability product or a product for harsh environments in a Renesas Electronics data sheet or other Renesas Electronics document, Renesas Electronics products are not subject to radiation resistance design. You are responsible for implementing safety measures to guard against the possibility of bodily injury, injury or damage caused by fire, and/or danger to the public in the event of a failure or malfunction of Renesas Electronics products, such as safety design for hardware and software, including but not limited to redundancy, fire control and malfunction prevention, appropriate treatment for aging degradation or any other appropriate measures. Because the evaluation of microcomputer software alone is very difficult and impractical, you are responsible for evaluating the safety of the final products or systems manufactured by you.
8. Please contact a Renesas Electronics sales office for details as to environmental matters such as the environmental compatibility of each Renesas Electronics product. You are responsible for carefully and sufficiently investigating applicable laws and regulations that regulate the inclusion or use of controlled substances, including without limitation, the EU RoHS Directive, and using Renesas Electronics products in compliance with all these applicable laws and regulations. Renesas Electronics disclaims any and all liability for damages or losses occurring as a result of your noncompliance with applicable laws and regulations.
9. Renesas Electronics products and technologies shall not be used for or incorporated into any products or systems whose manufacture, use, or sale is prohibited under any applicable domestic or foreign laws or regulations. You shall comply with any applicable export control laws and regulations promulgated and administered by the governments of any countries asserting jurisdiction over the parties or transactions.
10. It is the responsibility of the buyer or distributor of Renesas Electronics products, or any other party who distributes, disposes of, or otherwise sells or transfers the product to a third party, to notify such third party in advance of the contents and conditions set forth in this document.
11. This document shall not be reprinted, reproduced or duplicated in any form, in whole or in part, without prior written consent of Renesas Electronics.
12. Please contact a Renesas Electronics sales office if you have any questions regarding the information contained in this document or Renesas Electronics products.
(Note 1) "Renesas Electronics" as used in this document means Renesas Electronics Corporation and also includes its directly or indirectly controlled subsidiaries.
(Note 2) "Renesas Electronics product(s)" means any product developed or manufactured by or for Renesas Electronics.

(Rev.4.0-1 November 2017)



SALES OFFICES

Renesas Electronics Corporation

<http://www.renesas.com>

Refer to "<http://www.renesas.com/>" for the latest and detailed information.

Renesas Electronics America Inc.
1001 Murphy Ranch Road, Milpitas, CA 95035, U.S.A.
Tel: +1-408-432-8888, Fax: +1-408-434-5351

Renesas Electronics Canada Limited
9251 Yonge Street, Suite 8309 Richmond Hill, Ontario Canada L4C 9T3
Tel: +1-905-237-2004

Renesas Electronics Europe Limited
Dukes Meadow, Millboard Road, Bourne End, Buckinghamshire, SL8 5FH, U.K
Tel: +44-1628-651-700, Fax: +44-1628-651-804

Renesas Electronics Europe GmbH
Arcadiastrasse 10, 40472 Düsseldorf, Germany
Tel: +49-211-6503-0, Fax: +49-211-6503-1327

Renesas Electronics (China) Co., Ltd.
Room 1709 Quantum Plaza, No.27 ZhichunLu, Haidian District, Beijing, 100191 P. R. China
Tel: +86-10-8235-1155, Fax: +86-10-8235-7679

Renesas Electronics (Shanghai) Co., Ltd.
Unit 301, Tower A, Central Towers, 555 Langao Road, Putuo District, Shanghai, 200333 P. R. China
Tel: +86-21-2226-0888, Fax: +86-21-2226-0999

Renesas Electronics Hong Kong Limited
Unit 1601-1611, 16/F., Tower 2, Grand Century Place, 193 Prince Edward Road West, Mongkok, Kowloon, Hong Kong
Tel: +852-2265-6688, Fax: +852-2886-9022

Renesas Electronics Taiwan Co., Ltd.
13F, No. 363, Fu Shing North Road, Taipei 10543, Taiwan
Tel: +886-2-8175-9600, Fax: +886-2-8175-9670

Renesas Electronics Singapore Pte. Ltd.
80 Bendemeer Road, Unit #06-02 Hyflux Innovation Centre, Singapore 339949
Tel: +65-6213-0200, Fax: +65-6213-0300

Renesas Electronics Malaysia Sdn.Bhd.
Unit 1207, Block B, Menara Amcorp, Amcorp Trade Centre, No. 18, Jln Persiaran Barat, 46050 Petaling Jaya, Selangor Darul Ehsan, Malaysia
Tel: +60-3-7955-9390, Fax: +60-3-7955-9510

Renesas Electronics India Pvt. Ltd.
No.777C, 100 Feet Road, HAL 2nd Stage, Indiranagar, Bangalore 560 038, India
Tel: +91-80-67208700, Fax: +91-80-67208777

Renesas Electronics Korea Co., Ltd.
17F, KAMCO Yangjae Tower, 262, Gangnam-daero, Gangnam-gu, Seoul, 06265 Korea
Tel: +82-2-558-3737, Fax: +82-2-558-5338