

ISL6140/50EVAL1 Board

Negative Voltage Hot Plug Controller

AN9967
Rev 0.00
October 2001

The ISL6140 is an 8-pin, negative voltage hot plug controller that allows a board to be safely inserted and removed from a live backplane. Inrush current is limited to a programmable value by controlling the gate voltage of an external N-channel pass transistor. The pass transistor is turned off if the input voltage is less than the undervoltage threshold, or greater than the overvoltage threshold. A programmable electronic circuit breaker protects the system against shorts. The active low $\overline{\text{PWRGD}}$ signal can be used to directly enable a power module (with a low enable input)

The ISL6150 is the same part, but with an active high PWRGD signal.

Typical Application

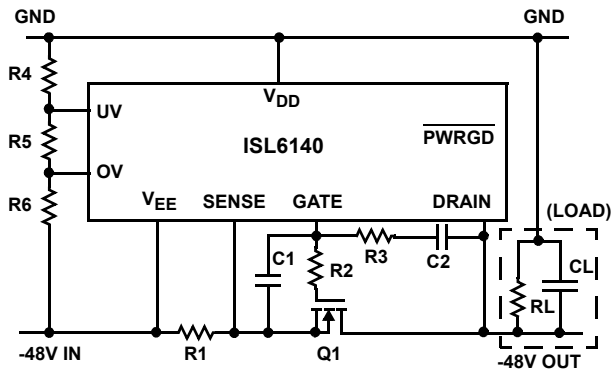

- R1 = 0.02Ω (1%)
- R2 = 10Ω (5%)
- R3 = 18kΩ (5%)
- R4 = 562kΩ (1%)
- R5 = 9.09kΩ (1%)
- R6 = 10kΩ (1%)
- C1 = 150nF (25V)
- C2 = 3.3nF (100V)
- Q1 = IRF530 (100V, 17A, 0.11Ω)
- CL = 100μF (100V)
- RL = equivalent resistance of the Load

Features (ISL6140/50)

- Low Side External NFET Switch
- Operates from -10V to -80V (-100V absolute max rating) or +10V to +80V (+100V absolute max rating)
- Programmable Inrush Current
- Programmable Electronic Circuit Breaker (overcurrent shutdown)
- Programmable Overvoltage Protection
- Programmable Undervoltage Lockout
- Power Good Control Output
 - $\overline{\text{PWRGD}}$ Active High: (H Version) ISL6150
 - $\overline{\text{PWRGD}}$ active Low: (L Version) ISL6140

Applications

- VoIP (Voice over Internet Protocol) Servers
- Telecom systems at -48V
- Negative Power Supply Control
- +24V Wireless Base Station Power

Related Literature

- ISL6140/50 Hot Plug Controller, Document # FN9039
- ISL6116 Hot Plug Controller, Document # FN4778

NOTE: See www.intersil.com/hotplug for more information.

Pinout

ISL6140 OR ISL6150 (8 LEAD SOIC)
TOP VIEW

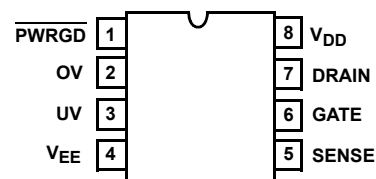

ISL6140 has active Low (L version) $\overline{\text{PWRGD}}$ output pin

ISL6150 has active High (H version) PWRGD output pin

Eval Board

- Three-board set with edge connectors to simulate live plug-ins
- Two independent channels, for comparison measurements
- Fully populated; requires only a 48V power supply to start

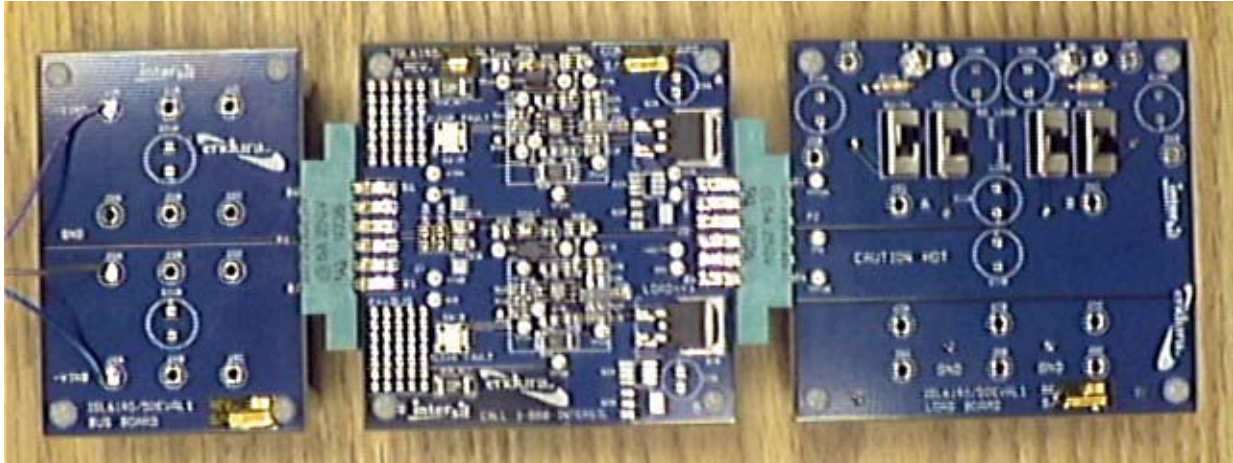

BUS BOARD

CONTROL BOARD

LOAD BOARD

FIGURE 1. THREE BOARD SET PHOTOGRAPH

Overview

This document assumes the reader is familiar with the hot plug concept, and has a copy of the ISL6140/50 datasheet referenced on the first page.

The ISL6140/50EVAL1 Board Set is made up of 3 boards (see Figures 1, 2, and 5 for various representations):

- BUS board: Input -48V power bus
- CONTROL board: IC hot-plug functions
- LOAD board: Load resistors and capacitors

This allows the user to simulate plugging a board into a live edge connector OR simulate plugging a live load into a motherboard.

- Wide voltage range (-10 to -80V); -48V typical. Most component values have been optimized for performance at -48V; some components need to be changed at either voltage extreme for optimal (or even acceptable) performance. For example, LED brightness is determined by the supply voltage through a current limiting resistor; the brightness at -10V is low, and high at -80V. If the board is to be used at a single fixed voltage level, some components might be changed to match.
- There are two identical channels (A and B); they can share one power supply (connect -VINA and -VINB together, either on the board, or externally), or they can each have their own supply (even at different voltages); there is no interaction between them (other than sharing the common GND); no power up or down sequencing is required. The default board is shipped with an ISL6140 in Channel A, and an ISL6150 in Channel B. See Figure 7 for schematic.
- The boards are labeled for negative supply operation; GND is the most positive voltage, and -VINA and -VINB are the most negative voltages. Note that GND is common for both channels on all three boards. Since

most IC signals are referenced to the negative rail, the user may want to reference the voltmeter and oscilloscope GNDs to the negative supply. However, be careful of earth GND connections (on power supplies or oscilloscopes) that don't match the user's GND.

- The boards can be used in a positive supply configuration, as long as the user renames (mentally or physically) the signals (the GND will become the positive supply, and -VINA and -VINB will become the new GND). Here, both supplies must be the same voltage.
- Boards are set for 54V max operation (using overvoltage shutdown) to protect the load resistors. Users have the option to change components and substitute alternate loads. UV is set at 37V.
- Typical load is a -48V to 5V brick regulator.

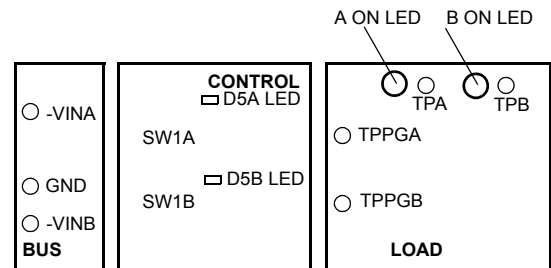

FIGURE 2. LEDs AND TEST POINTS

BUS board (Input -48V Power; Fig. 6)

- Multiple large holes for soldering wires, posts, pins, etc. for input power (-48V and GND typical)
- Holes for optional input caps
- Edge connector pins plug into Control board
- Short pin GND to simulate last pin making contact

CONTROL Board (IC Hot-Plug; Fig. 7)

- 2 Identical hot plug channels
- compare Intersil ISL6140 (L) to ISL6150 (H), or to any other present or future pin-compatible device
- change components for alternate applications
- Red "FAULT" LED (PowerGood; for ISL6140 only); jumper to disconnect it (if it interferes with logic level)
- Push-button Switch for overcurrent latch reset
- Footprints for 3 FET outlines; D2PAK, SO-8, SOT-223
- short pin connection for UV lockout
- testpoint for each IC pin
- small bread-board area for adding user circuitry
- (approximate) minimum board area highlighted
- Board Application Options (See "Optional Components" section)
- Load capacitors
- RC filter on VDD
- RC delay on overcurrent shutdown
- Drain diodes
- Overvoltage clamping suppressor
- Green LED for PowerGood OK (ISL6140 only)
- Spare (alternate) Sense Resistor included

LOAD Board (R and C Loads; Fig 8)

- Edge connector pins plug into Control board
- Typical Load current is <100mA (limited by power dissipation of the load resistors); overcurrent trip is ~185mA.
- Two load resistors for each channel; one ~80mA, 2nd ~160mA; both together ~240mA (Over-load).
- Switches to connect the loads in and out
- Multiple holes for soldering wires, pins, posts, for external output load connections (brick regulators are too big and varied to include on the board).
- Holes for optional load caps
- PowerGood signal from each channel brought over through edge connector, for use with brick regulator; available on testpins
- LED Channel "ON" indication

-48V Hook-Up Instructions

1. Get one (or two) -48V power supplies (~0.25A current needed per channel; 0.5A total). A positive supply can also be used as long as the user keeps the polarities correct. The two channels can share one voltage supply, can each have their own similar supply, or can even have two

different voltages (no special sequence is needed). If only one channel is being tested, the other can be left unconnected. The following instructions are the same for both channels. As shown in Fig. 3, A1 is an optional ammeter to measure current; V1 is a Voltmeter to measure power supply voltage, and V2 is a voltmeter to look at other signals. Note that the voltmeters are referenced to the negative supply rail.

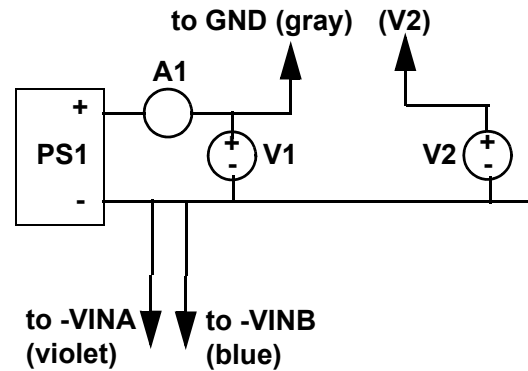

FIGURE 3. HOOK UP

NOTE: If the user substitutes higher current external loads, the power supply capability would need to be increased accordingly.

2. All Power off.
3. Connect the gray wire to GND (or most positive voltage); connect the -VINA (violet) and -VINB (blue) wire(s) to -48V (or the most negative voltage).
4. Plug the 3 boards together; from left to right, should be BUS, CONTROL, and LOAD (those labels should be upright, facing the user). Set the switches on the LOAD board to the "No Load" position.
5. Turn on supplies to -48V. The FETs should turn on, switching the -VIN voltages to -VOUT; the A ON and B ON LED(s) on the LOAD board should be on. Power supply current (if monitored) should be only a few milli-Amps.
6. A simple check for UV (undervoltage) and OV (overvoltage) can be done, when using a variable power supply. From the -48V normal start, increase the voltage to >-54V; the FETs and "ON" LEDs should turn off, until the voltage is lowered (There should be about one volt of hysteresis). Similarly, bring the voltage to <-37V to turn off the FETs and LEDs; again, there is some hysteresis to turn them back on.

NOTE: The Fault LED is not compatible with the ISL6150; it will always be on as long as the input power supply is on. That is why the jumper is disconnected. In addition, one of the loads may need to be switched on for the "ON" LEDs to respond properly to OV or UV.

7. Switch on Loads: At 48V, SW11 by itself should give ~80mA of current; SW12 by itself should give ~160mA of current. Both together should give ~240mA, which is over the preset Overcurrent level ($0.05V/0.27\text{ohm} = 185\text{ mA}$). The FET should turn off, the A/B ON LED should go off, the Fault LED should turn on. To return to normal operation, unswitch one or both load resistors, and press and release SW1 (which pulls down on the UV pin, to reset the internal fault latch).
8. Disconnect the BUS board from the CONTROL/LOAD; now plug it back in; this simulates a hot plug board being

inserted into a live connector. The FETs should turn on in a controlled manner, based on the gate timing components.

9. Disconnect the BUS/CONTROL from the LOAD; now plug it back in; this simulates a load being plugged into a powered hot plug on the motherboard.

Other Notes:

Current Monitoring: There are several ways to monitor load currents. A voltmeter can be placed across the R1 sense resistor, to calculate the current ($I = V/R$; $R = 0.27$ ohms).

For more for detailed measurements, a current probe connected to an oscilloscope can be used. First, place all of the load switches in the “No Load” position. Add an wire loop between -VOUTA (or -VOUTB) to an external load and then back to GND. The load resistors can also be used; just connect the wire loop from -VOUT to one of the load resistor’s terminal closest to the switch. Now the load current will flow through the wire loop, and can be monitored. Note that the LED current (~1mA) will not be included in the current loop; but if it interferes with a “zero” current condition, then just un-solder the R13 resistor, in order to disconnect it.

Alternate sense resistor: The R1 sense resistor on the board is 0.27 ohm; this sets the overcurrent shutdown at 185mA. This was done primarily to allow reasonably sized load resistors to be used for initial demonstrations. However, the IC and the boards are certainly capable of switching much higher currents, as long as the user supplies his own external load (the Q1 IRF530 FET, for example, is rated up to 17A). Therefore, an R1_alt of 0.02 ohms is also supplied on the board for each channel. Un-solder R1 and solder R1_alt in its place. This will set the overcurrent shutdown at $I = V/R = 50\text{mV}/20\text{mohms} = 2.5$ Amps. Similarly, the user can supply his own alternate value to set the trip point wherever he wants to. Keep in mind that the power supply must also be rated to handle the higher load current.

Overvoltage is set to 54V to protect the load resistors; the R4,R5,R6 values can be changed for other loads. A more typical value for OV is around 71V, the high end of the range for a 48V supply application. See the ISL6140 datasheet for more details on how to select the resistors.

There are many test pins that can be used for meter or oscilloscope probes. Discrete components might even be soldered to them, if necessary. See the various “Board Labels” section.

Additional or alternative loads can be externally connected to the LOAD board.

Individual components can be un-soldered and replaced with alternative values, if desired.

There are many optional components that can be soldered in, as desired (see “Optional Components” section).

Be sure the external components are properly rated for the application voltage; this is especially true for input or output

capacitors, for example; they should be rated for 100V, if the full voltage range will be used.

The fault LED is intended for display purposes; the implementation used is not necessarily a satisfactory solution for a production design. Aside from being useful only with the ISL6140, the brightness varies greatly with the supply voltage. If the signal is to be used as a logic output, as well as drive an LED, then the voltage level must also be compatible with the signal it drives (the jumper JP1 disconnects the LED from the pin, to separate the functions). The present circuit also clamps the output voltage; a 3V zener diode was included to make the clamp voltage around 4.5V, compatible with most logic levels. Finally, the LED provides a current path between the PWRGD pin back to the VEE pin, when the FET is off; this may not be desirable in the system (referencing the LED to the DRAIN pin doesn’t work, since under most faults, when the FET turns off, the DRAIN will then be floating).

Since the ISL6140 PWRGD output is an open-drain, pull-down device, an LED connected to the positive supply is another option. But since the LED will be on during normal operation, and off during a fault, a green “OK” LED is suggested. See “Optional Components” section for more details.

Required Components (Same for both A and B channels; See Fig. 4 and 7)

U1 is the ISL6140 (L) or ISL6150 (H) Intersil hot plug controller IC; the only difference between the two part numbers is the polarity of the PWRGD output (pin 1).

R4, R5, R6, are the resistors that divide the input power supply voltage down to the overvoltage (OV) and undervoltage (UV) trip points. The top of the resistor divider is connected to the short-pin GND.

R3, C2, R2, C1 control the inrush current, prevent momentary turn-on during power-up, and keep the gate pin from oscillating. See ISL6140/50 datasheet for more details.

R1 is the Overcurrent sense resistor. $I = 50 \text{ mV} / R1$.

Q1 is the FET that switches the voltage from the input BUS to the LOAD. It uses a D2PAK package.

R8, R9, D4, D5 create the red LED “FAULT” indication for the ISL6140 (L version). R8 sets the LED current; R9 is just a zero ohm placeholder; D5 is the LED, and D4 is a 3V zener. Note that when the PWRGD open-drain pull-down output turns on (Power is Good), the fault LED is off. When the output turns off, the fault LED will turn on; the voltage would rise to a high value, but the zener and LED will clamp it to approximately 4.5V.

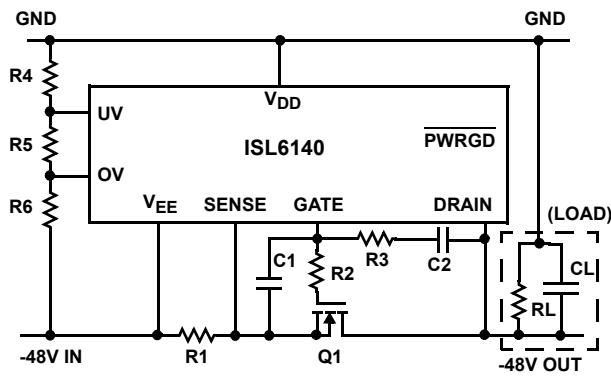

FIGURE 4. TYPICAL APPLICATION

TABLE 1. NEEDS A DESCRIPTION

R1 = 0.02Ω (1%)	C1 = 150nF (25V)
R2 = 10Ω (5%)	C2 = 3.3nF (100V)
R3 = 18kΩ (5%)	Q1 = IRF530 (100V, 17A, 0.11Ω)
R4 = 562kΩ (1%)	CL = 100μF (100V)
R5 = 9.09kΩ (1%)	RL = equivalent resistance of the Load
R6 = 10kΩ (1%)	

Optional Components (Same for both A and B channels; See Fig. 7)

R10 and C4 make an RC filter for the VDD pin. It is used to isolate some kinds of system supply noise from the IC. For example, it may help filter out glitches that could trigger OV or UV (which shut off the FET) if near their trip points.

D1 is a voltage suppressor, which can help protect the board components from transient voltages that exceed the normal operating range allowed (absolute maximum is 100V).

D2 and D3 may be used to block inductive transients that might pull the drain pin negative with respect to the VEE pin. The ISL6140 (L version) uses one diode (D2); the ISL6150 (H version) uses both diodes. The diodes have a second effect of offsetting the drain trip points for the PWRGD output. The default board has one of the diodes shorted out with zero ohms; that should be removed before adding one or two diodes.

R7 and C3 make an RC time constant to lengthen the time allowed in the overcurrent condition, before shutting down. Without them, any pulse longer than the 2–4 usec spec would latch off the output. If noise pulses wider than that are expected (and won't cause other damage), then set the filter to a time longer than those pulses. Note, however, that the FET must be able to safely handle the current and power dissipation for that longer time period. The default boards are shipped with R7 = zero ohms.

Q2 and Q3 are alternate package options for Q1 FETs. Q2 is an 8-pin SOIC, using a standard pinout (S=1, 2, 3, G=4, D=5-

8). Q3 is an SOT-223 package. Since all three pins of all three packages are wired in parallel, with no jumpers, it is recommended that only one of the 3 be populated at any given time.

R1_alt is a 20 milli-ohm sense resistor; if used instead of R1 (un-solder R1, and solder in R1_alt), it will produce an overcurrent trip point of (50mV / 20 mOhms) = 2.5 Amps. CAUTION: The load resistors supplied with the LOAD board combined only give about 0.25Amps for each channel; an additional external load or shorting mechanism will then be needed to trip the overcurrent.

C5 is a load capacitor that can be placed on the CONTROL board (in addition to the three cap footprints on the LOAD board). It can be any value consistent with the application. Note the polarity for electrolytic capacitors.

D6 is a green LED that can be used as a PWRGD "OK" indicator, instead of a red "FAULT" LED. It should only be used with the ISL6140. R8 sets the LED current; D6 LED replaces R9, and D4 and D5 are disconnected (remove either one to open circuit).

BUS Board Labels (See Fig. 11)

- -VINA = J1A, J1B, J1C
- GND = J2A, J2B, J2C
- GND = J3A, J3B, J3C
- -VINB = J4A, J4B, J4C
- C21A = optional input capacitor for -VINA (to GND)
- C21B = optional input capacitor for -VINB (to GND)

Edge Connector Pins P1;

- top pins B6, B5, B4 = -VINA
- top pins B3, B2, B1 = -VINB
- bottom pins A6 - A1 = GND
- (note that pin A3 is shorter than the others; this pin is thus expected to be the last one to make contact; it is used to hold the IC's in reset until all pins are have made good contact).

CONTROL Board Labels (See Fig. 10)

Edge Connector Jack J1

- top pins B6, B5, B4 = -VINA
- top pins B3, B2, B1 = -VINB
- bottom pins A6, A5, A4, A2, A1 = GND
- bottom pin A3 = SHORT GND (last pin to make contact; connected to the UV/OV resistor divider on both channels)
- JP2A and JP2B are optional jumpers (not populated); if the SHORT GND function is not desired, connecting the two pins on either jumper will effectively eliminate the

shorter pin (the UV/OV resistor divider will be connected to the longer GND pins).

Edge Connector Jack J2

- top pins B6, B5, B4 = -VOUTB
- top pins B3, B2, B1 = -VOUTA
- bottom pins A5, A4, A3, A2, = GND
- bottom pins A1 = PWRGDA; A6 = PWRGDB (these signals are brought over to the LOAD board, in the event the user needs them (for example, to enable a brick regulator). There is also test point for each (TPPGA, TPPGB) on the LOAD board.

Test Pins

- -VINA, GND, -VINB, GND (from J1)
- TP1A - TP8A (each IC pin number has its own TP)
- TP1B - TP8B (each IC pin number has its own TP)
- -VOUTA, GND, -VOUTB, GND (from J2)

Switches

- SW1A = momentary contact pushbutton to bring Channel A UV (IC pin 3) to VEE, in order to clear overcurrent fault latch.
- SW1B = same as above for Channel B

Jumpers

- JP1A = shorting the two pins together connects the Channel A PWRGD signal (IC pin 1) to the red fault LED indicator. This jumper should be removed for the ISL6150 (H version), because the LED circuit is not valid; (the LED would remain on for either state), and should also be removed if the LED circuit interferes with the logic levels needed externally (such as for a brick regulator; the present board clamps to ~4.5V when the LED is on). Note that this circuit may not be the most efficient or cost-effective; it is just meant to be functional for the Eval board.
- JP1B = same as above for Channel B

LEDs

- D5A = red "FAULT" LED; it comes on if the $\overline{\text{PWRGD}}$ pin on the ISL6140 goes high; it represents some kind of fault, usually a shorted output or an overcurrent shutdown; it will also become active if the FET is turned off for OV or UV.
- D5B = same as above for Channel B.

LOAD Board Labels (See Fig. 9)

CAUTION HOT

The load resistors are mounted on the bottom of the LOAD board, but the heat can be felt through the top of the board. Be careful how you handle the board, especially while gripping it for plugging or unplugging.

Edge Connector Pins P2;

- top pins B6, B5, B4 = -VOUTB
- top pins B3, B2, B1 = -VOUTA
- bottom pins A5, A4, A3, A2 = GND
- bottom pins A1 = PWRGDA; A6 = PWRGDB

Test Pins

- TPPGA (J1, pin A1); PWRGDA
- TPPGB (J1, pin A6); PWRGDB
- TPG (J1, pin A5 - A2); GND
- TPA (also J5A, J5B, J5C); -VOUTA
- TPB (also J6A, J6B, J6C); -VOUTB
- J7A, J7B, J7C, J8A, J8B, J8C; GND

Optional Capacitors

- C11A, C12A, C13A; for -VOUTA
- C11B, C12B, C13B; for -VOUTB

Switches (note the Load and No Load positions)

- SW11A is a nominal load R11A for -VOUTA
- SW12A is a higher nominal load R12A for -VOUTA
- Both Switches together should create an overcurrent shutdown for Channel A (with R1 = 0.27 ohms)
- SW11B is a nominal load R11B for -VOUTB
- SW12B is a higher nominal load R12B for -VOUTB
- Both Switches together should create an overcurrent shutdown for Channel B (with R1 = 0.27 ohms)

LEDs

- D11A is on when -VOUTA is switched on (through the Q1A FET). Note it is independent of whether either of the load resistors is connected.
- Same as above for Channel B (Note that D11B was not labeled on the board; look for "B ON").

ISL6140/50 EVAL boards (BUS Input, CONTROL, LOAD Output)

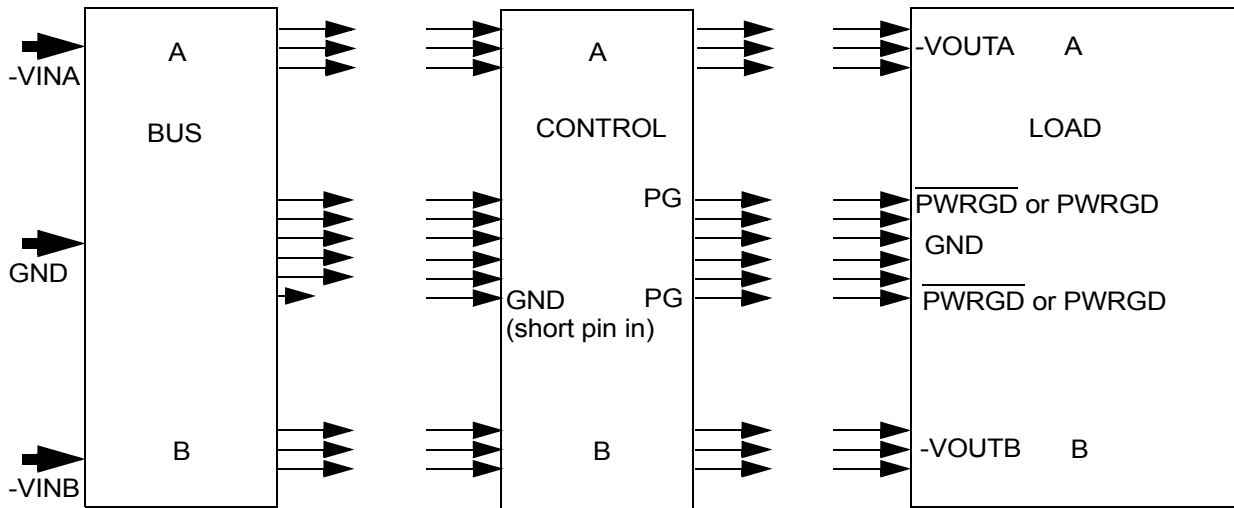

FIGURE 5. THREE BOARD SET

ISL6140/50 EVAL boards BUS (Input)

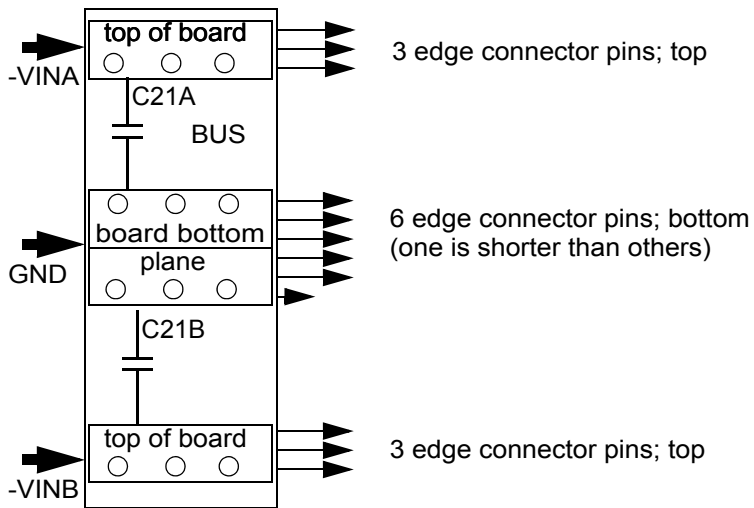

FIGURE 6. BUS BOARD SCHEMATIC

ISL6140/50 EVAL board (CONTROL)
 (Two identical channels (A/B) on board; all components have a suffix A or B).

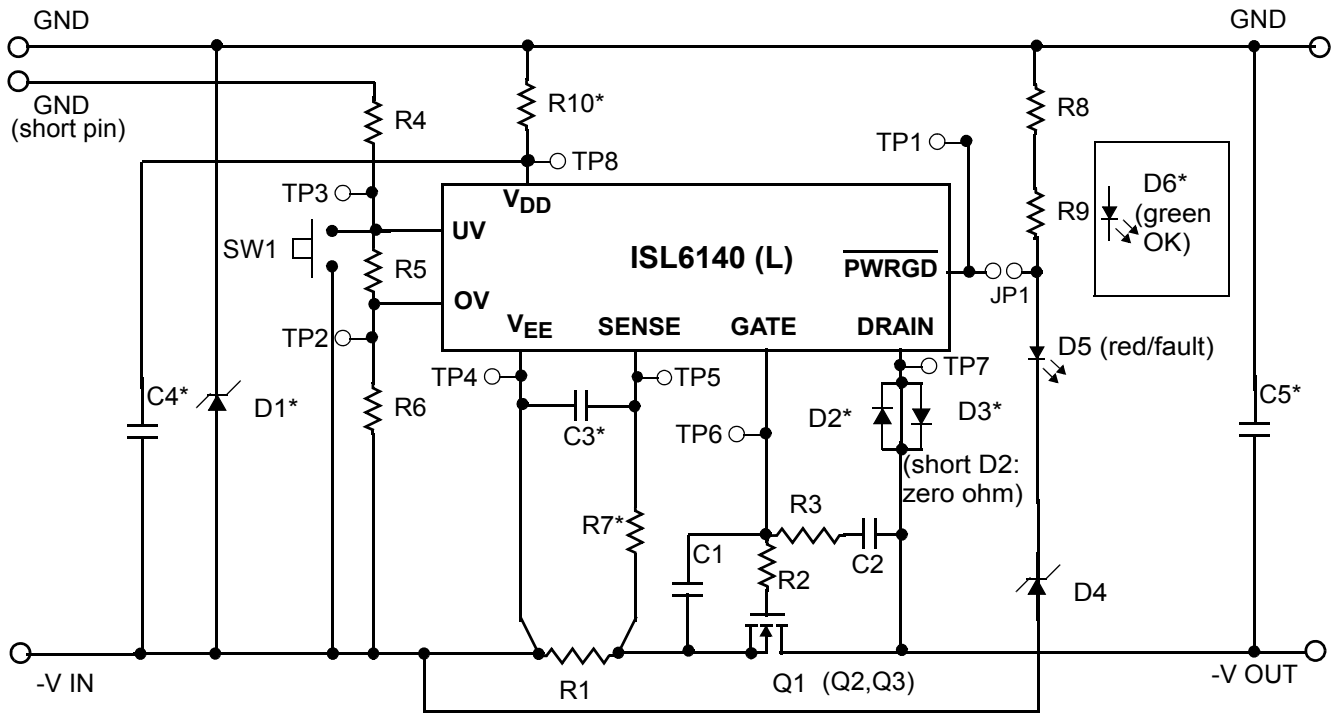

FIGURE 7. CONTROL BOARD SCHEMATIC

ISL6140/50 EVAL boards LOAD (Output)

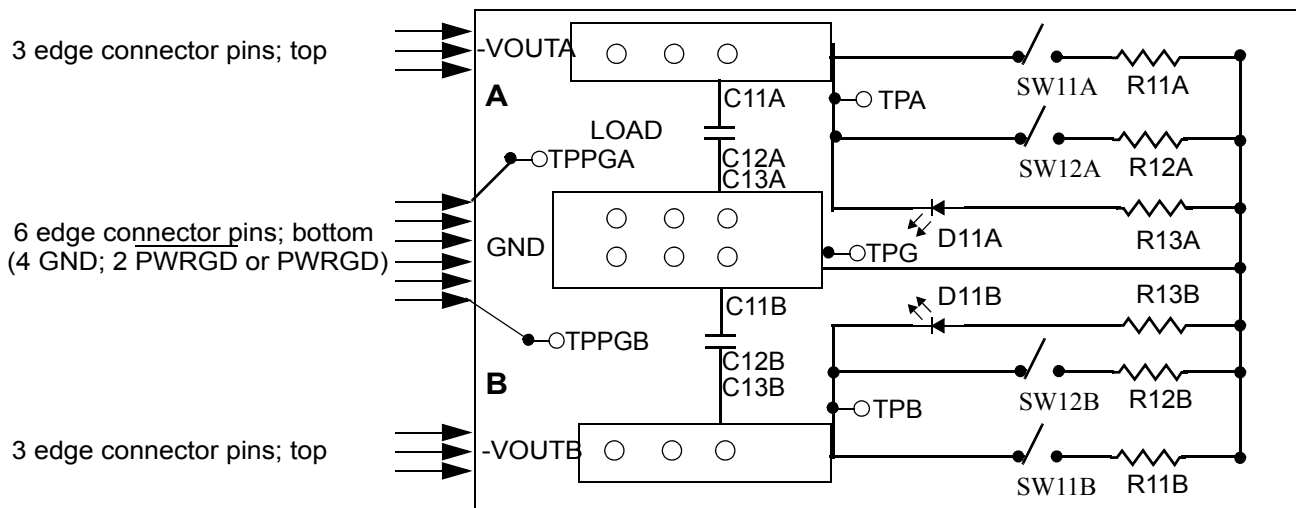

FIGURE 8. LOAD BOARD SCHEMATIC

Bill Of Material**TABLE 2. BILL OF MATERIAL**

Component	Name	Size	Description
	CONTROL BOARD BOM		
U1 A/B	ISL6140 (A); ISL6150 (B)	8-SOIC	
Q1 A/B	IRF530 or equivalent	SMD-220(D2PAK)	
Q2 A/B	Optional FET	8-SOIC	DNP;
Q3 A/B	Optional FET	SOT-223	DNP;
R1 A/B	Current Sense Resistor	2512, 0.27ohm,5%	1W
R1_alt A/B	Current Sense Resistor (alternate)	2512, 20mohm,1%	1W
R2 A/B	Gate Resistor	0805,10 ohm,5%	
R3 A/B	Power up Resistor	0805,18k ohm,5%	
R4 A/B	UV/OV resistor divider	0805,562k ohm,1%	
R5 A/B	UV/OV resistor divider	0805,5.9k ohm,1%	
R6 A/B	UV/OV resistor divider	0805,13.3k ohm,1%	
R7 A/B	(Placeholder); OC time stretch	0805,0 ohm,5%	optional RC stretch (with C3)
R8 A/B	LED current Resistor	1210,39k ohm,5%	1/4W
R9 A/B	(Placeholder);	0805,0 ohm,5%	optional green "OK" LED
R10 A/B	(Placeholder); RC filter for VDD	0805,0 ohm,5%	optional RC filter (with C4)
C1 A/B	Power up Capacitor	0805,150nF,25V	
C2 A/B	Feedback Capacitor	0805,3.3nF,100V	
C3 A/B	Optional RC	0805	DNP (with R7)
C4 A/B	Optional RC filter for VDD	0805,0.1uF,100V	DNP
C5 A/B	Optional Load Capacitor	electrolytic	DNP; Through-hole;
D1 A/B	SMAT70A	SMA	Voltage suppressor
D2,D3 A/B	1N4148	SOD-123; 75V	Blocking diode
D4 A/B	3V zener diode	S-mini 2P	
D5 A/B	Red LED	0805	
D6 A/B	Green LED	0805	DNP; optional
SW1 A/B	UV reset push button;		Normally Open
JP1 A/B	Two Pin Jumper; shorting shunt		Isolate PWRGD, LED
	BUS BOARD BOM		
C21 A/B	Optional Input Capacitor	electrolytic	DNP: through-hole;
	LOAD BOARD BOM		
R11 A/B	Load Resistor	620 ohm,5%,5W	through-hole;
R12 A/B	Over-Load Resistor	330 ohm,5%,10W	through-hole;
R13 A/B	LED Current Resistor	39 kohm, 5%, 1/4W	through-hole;

TABLE 2. BILL OF MATERIAL (Continued)

Component	Name	Size	Description
D11 A/B	Red LED	T1-3/4	through-hole;
SW11 A/B SW12 A/B	Load Slide Switch		through-hole;
C11 A/B C12 A/B C13 A/B	Optional Load Capacitors	electrolytic	DNP; through-hole;
	Note: Surface Mount Resistors are 1/10W unless otherwise noted		
	Note: DNP = Do Not Populate		

Component Placement and Labels

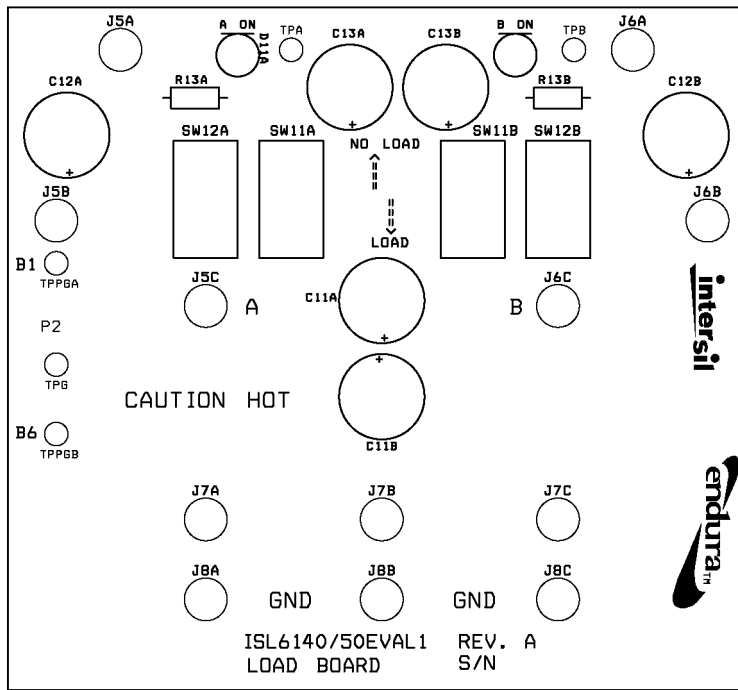

NOTE: D11B NOT LABELED

FIGURE 9. LOAD BOARD

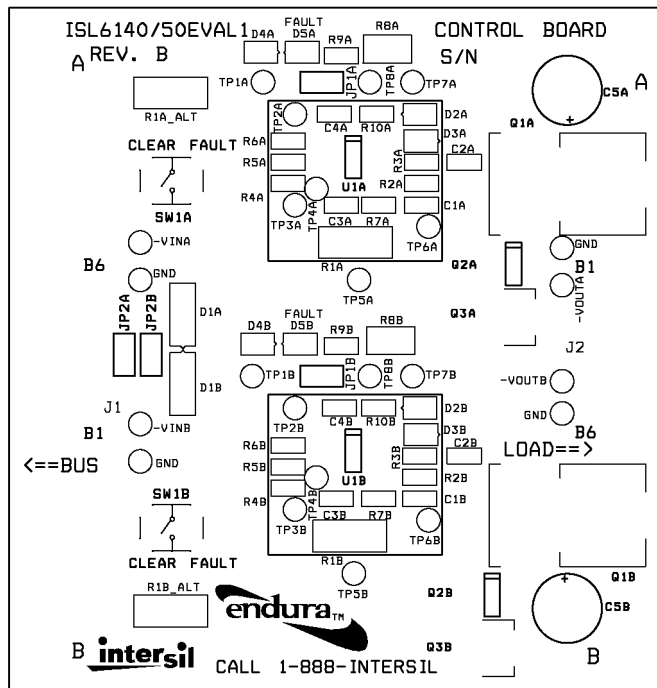

FIGURE 10. CONTROL BOARD

Component Placement and Labels

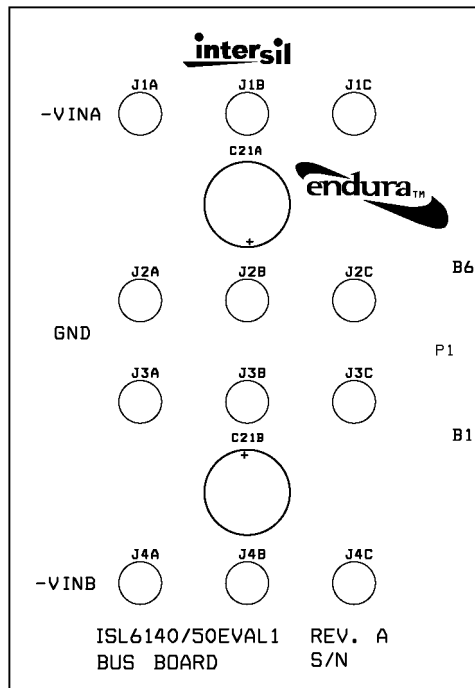

FIGURE 11. BUS BOARD

Notice

1. Descriptions of circuits, software and other related information in this document are provided only to illustrate the operation of semiconductor products and application examples. You are fully responsible for the incorporation or any other use of the circuits, software, and information in the design of your product or system. Renesas Electronics disclaims any and all liability for any losses and damages incurred by you or third parties arising from the use of these circuits, software, or information.
2. Renesas Electronics hereby expressly disclaims any warranties against and liability for infringement or any other claims involving patents, copyrights, or other intellectual property rights of third parties, by or arising from the use of Renesas Electronics products or technical information described in this document, including but not limited to, the product data, drawings, charts, programs, algorithms, and application examples.
3. No license, express, implied or otherwise, is granted hereby under any patents, copyrights or other intellectual property rights of Renesas Electronics or others.
4. You shall not alter, modify, copy, or reverse engineer any Renesas Electronics product, whether in whole or in part. Renesas Electronics disclaims any and all liability for any losses or damages incurred by you or third parties arising from such alteration, modification, copying or reverse engineering.
5. Renesas Electronics products are classified according to the following two quality grades: "Standard" and "High Quality". The intended applications for each Renesas Electronics product depends on the product's quality grade, as indicated below.
"Standard": Computers; office equipment; communications equipment; test and measurement equipment; audio and visual equipment; home electronic appliances; machine tools; personal electronic equipment; industrial robots; etc.
"High Quality": Transportation equipment (automobiles, trains, ships, etc.); traffic control (traffic lights); large-scale communication equipment; key financial terminal systems; safety control equipment; etc.
Unless expressly designated as a high reliability product or a product for harsh environments in a Renesas Electronics data sheet or other Renesas Electronics document, Renesas Electronics products are not intended or authorized for use in products or systems that may pose a direct threat to human life or bodily injury (artificial life support devices or systems; surgical implantations; etc.), or may cause serious property damage (space system; undersea repeaters; nuclear power control systems; aircraft control systems; key plant systems; military equipment; etc.). Renesas Electronics disclaims any and all liability for any damages or losses incurred by you or any third parties arising from the use of any Renesas Electronics product that is inconsistent with any Renesas Electronics data sheet, user's manual or other Renesas Electronics document.
6. When using Renesas Electronics products, refer to the latest product information (data sheets, user's manuals, application notes, "General Notes for Handling and Using Semiconductor Devices" in the reliability handbook, etc.), and ensure that usage conditions are within the ranges specified by Renesas Electronics with respect to maximum ratings, operating power supply voltage range, heat dissipation characteristics, installation, etc. Renesas Electronics disclaims any and all liability for any malfunctions, failure or accident arising out of the use of Renesas Electronics products outside of such specified ranges.
7. Although Renesas Electronics endeavors to improve the quality and reliability of Renesas Electronics products, semiconductor products have specific characteristics, such as the occurrence of failure at a certain rate and malfunctions under certain use conditions. Unless designated as a high reliability product or a product for harsh environments in a Renesas Electronics data sheet or other Renesas Electronics document, Renesas Electronics products are not subject to radiation resistance design. You are responsible for implementing safety measures to guard against the possibility of bodily injury, injury or damage caused by fire, and/or danger to the public in the event of a failure or malfunction of Renesas Electronics products, such as safety design for hardware and software, including but not limited to redundancy, fire control and malfunction prevention, appropriate treatment for aging degradation or any other appropriate measures. Because the evaluation of microcomputer software alone is very difficult and impractical, you are responsible for evaluating the safety of the final products or systems manufactured by you.
8. Please contact a Renesas Electronics sales office for details as to environmental matters such as the environmental compatibility of each Renesas Electronics product. You are responsible for carefully and sufficiently investigating applicable laws and regulations that regulate the inclusion or use of controlled substances, including without limitation, the EU RoHS Directive, and using Renesas Electronics products in compliance with all these applicable laws and regulations. Renesas Electronics disclaims any and all liability for damages or losses occurring as a result of your noncompliance with applicable laws and regulations.
9. Renesas Electronics products and technologies shall not be used for or incorporated into any products or systems whose manufacture, use, or sale is prohibited under any applicable domestic or foreign laws or regulations. You shall comply with any applicable export control laws and regulations promulgated and administered by the governments of any countries asserting jurisdiction over the parties or transactions.
10. It is the responsibility of the buyer or distributor of Renesas Electronics products, or any other party who distributes, disposes of, or otherwise sells or transfers the product to a third party, to notify such third party in advance of the contents and conditions set forth in this document.
11. This document shall not be reprinted, reproduced or duplicated in any form, in whole or in part, without prior written consent of Renesas Electronics.
12. Please contact a Renesas Electronics sales office if you have any questions regarding the information contained in this document or Renesas Electronics products.
(Note 1) "Renesas Electronics" as used in this document means Renesas Electronics Corporation and also includes its directly or indirectly controlled subsidiaries.
(Note 2) "Renesas Electronics product(s)" means any product developed or manufactured by or for Renesas Electronics.

(Rev.4.0-1 November 2017)



SALES OFFICES

Renesas Electronics Corporation

<http://www.renesas.com>

Refer to "<http://www.renesas.com/>" for the latest and detailed information.

Renesas Electronics America Inc.
1001 Murphy Ranch Road, Milpitas, CA 95035, U.S.A.
Tel: +1-408-432-8888, Fax: +1-408-434-5351

Renesas Electronics Canada Limited
9251 Yonge Street, Suite 8309 Richmond Hill, Ontario Canada L4C 9T3
Tel: +1-905-237-2004

Renesas Electronics Europe Limited
Dukes Meadow, Millboard Road, Bourne End, Buckinghamshire, SL8 5FH, U.K
Tel: +44-1628-651-700, Fax: +44-1628-651-804

Renesas Electronics Europe GmbH
Arcadiastrasse 10, 40472 Düsseldorf, Germany
Tel: +49-211-6503-0, Fax: +49-211-6503-1327

Renesas Electronics (China) Co., Ltd.
Room 1709 Quantum Plaza, No.27 ZhichunLu, Haidian District, Beijing, 100191 P. R. China
Tel: +86-10-8235-1155, Fax: +86-10-8235-7679

Renesas Electronics (Shanghai) Co., Ltd.
Unit 301, Tower A, Central Towers, 555 Langao Road, Putuo District, Shanghai, 200333 P. R. China
Tel: +86-21-2226-0888, Fax: +86-21-2226-0999

Renesas Electronics Hong Kong Limited
Unit 1601-1611, 16/F., Tower 2, Grand Century Place, 193 Prince Edward Road West, Mongkok, Kowloon, Hong Kong
Tel: +852-2265-6688, Fax: +852-2886-9022

Renesas Electronics Taiwan Co., Ltd.
13F, No. 363, Fu Shing North Road, Taipei 10543, Taiwan
Tel: +886-2-8175-9600, Fax: +886-2-8175-9670

Renesas Electronics Singapore Pte. Ltd.
80 Bendemeer Road, Unit #06-02 Hyflux Innovation Centre, Singapore 339949
Tel: +65-6213-0200, Fax: +65-6213-0300

Renesas Electronics Malaysia Sdn.Bhd.
Unit 1207, Block B, Menara Amcorp, Amcorp Trade Centre, No. 18, Jln Persiaran Barat, 46050 Petaling Jaya, Selangor Darul Ehsan, Malaysia
Tel: +60-3-7955-9390, Fax: +60-3-7955-9510

Renesas Electronics India Pvt. Ltd.
No.777C, 100 Feet Road, HAL 2nd Stage, Indiranagar, Bangalore 560 038, India
Tel: +91-80-67208700, Fax: +91-80-67208777

Renesas Electronics Korea Co., Ltd.
17F, KAMCO Yangjae Tower, 262, Gangnam-daero, Gangnam-gu, Seoul, 06265 Korea
Tel: +82-2-558-3737, Fax: +82-2-558-5338