

ISL85033-12VEVAL3Z

Wide VIN Negative VOUT Buck-Boost Regulator With Up to 5A Output Current

AN1636
Rev 1.00
July 27, 2011

Hardware Description

The ISL85033 is a wide input range, dual standard buck converter that can be configured to provide a negative output voltage. The ISL85033-12VEVAL3Z evaluation board is used in this application note to demonstrate the negative configuration. In this configuration, V_{IN} can range from 4.5V to (28V - V_{OUT}).

The ISL85033 is offered in a 4mmx4mm 28 Ld TQFN package with 1mm maximum height. The complete converter occupies 6.25cm² area.

Key Features

- Wide Input Voltage Range from 4.5V to (28V - V_{OUT})
- Adjustable and Synchronizable Negative Output Voltage with Continuous Output Current up to 5A, depending on V_{OUT} and V_{IN}
- Current Mode Control
- Adjustable Switching Frequency from 300kHz to 2MHz
- Power-Good Detection (referenced to V_{OUT})
- Externally Adjustable Soft-start Time
- Overcurrent and Hiccup Mode Short Circuit Protection, Thermal Overload Protection, UVLO
- Boot Undervoltage Detection
- Default Out-of-phase Channels Reduce Voltage Ripple and Component Size. User-selectable Phase Operation.

Recommended Equipment

The following materials are recommended to perform testing:

- 0V to 30V power supply with at least 7A source current capability or a 5V battery
- Electronic loads capable of sinking current up to 7A
- Digital multimeters (DMMs)
- 100MHz quad-trace oscilloscope
- Signal generator

Quick Setup Guide

1. Ensure that the circuit is correctly connected to the supply and loads prior to applying any power.
2. Connect the bias supply to VIN1, the plus terminal to VIN1, and the negative return to GND1.
3. Verify that the position is ON for S1.
4. Turn on the power supply.
5. Verify the output voltage is -12V for V_{OUT} .

Evaluating the Other Output Voltages

The ISL85033-12VEVAL3Z kit output is preset to -12V; however, output voltages can be adjusted from -3.3V to -15V. The output voltage programming resistor, R3, depends on the desired output voltage of the regulator. The value for the feedback resistor is typically between 0Ω and 142kΩ as shown in Equation 1.

$$R3 = R2 \left(\frac{V_{OUT}}{V_{FB}} - 1 \right) \quad (EQ. 1)$$

Table 1 summarizes the external component selection for $V_{OUT} = -5V$, $V_{OUT} = -12V$, and $V_{OUT} = -15V$.

TABLE 1. COMPONENT SELECTION FOR V_{OUT}

V_{OUT}	EXTERNAL COMPONENTS
-5V	R3 = 43.2k; R5 = 20k; C4 = 2.7nF C20 = 22μF (1210 ceramic) C17 = 22μF (1210 ceramic) C19 = 68μF (15mΩ polymer EEFUD0K680R)
-12V	R3 = 112k; R5 = 120k; C4 = 4.7nF C14, C17 = 22μF (2210 ceramic) C12, C19 = 68μF (70mΩ TaNbO2 TPSD686M020R0070) C20 = DNP
-15V	R3 = 142k; R5 = 120k; C4 = 4.7nF C14, C17 = 22μF (2210 ceramic) C12, C19 = 68μF (70mΩ TaNbO2 TPSD686M020R0070) C20 = DNP

The curves in Figure 1 indicate the maximum output current the converter can deliver as a function of the input voltage and the selected output voltage configuration.

Figures 2, 3 and 4 show the efficiency for different V_{IN} , V_{OUT} and load combinations.

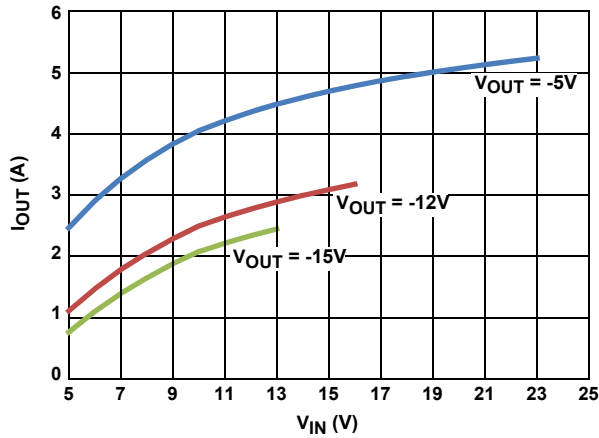

FIGURE 1. ISL85033-12VEVAL3Z BUCK BOOST: RECOMMENDED MAXIMUM I_{OUT} (V_{IN})

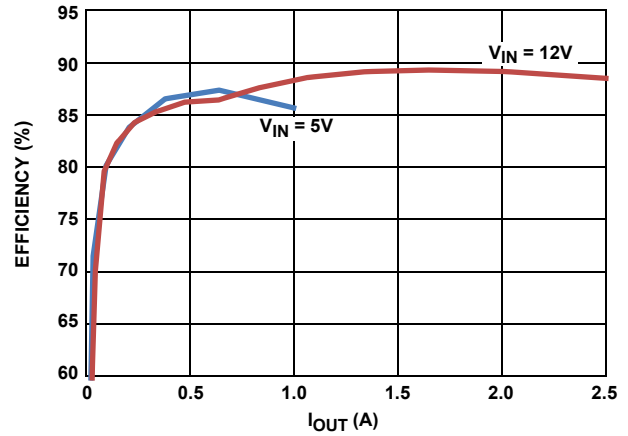

FIGURE 2. ISL85033-12VEVAL3Z EFFICIENCY: $V_{OUT} = -15V$

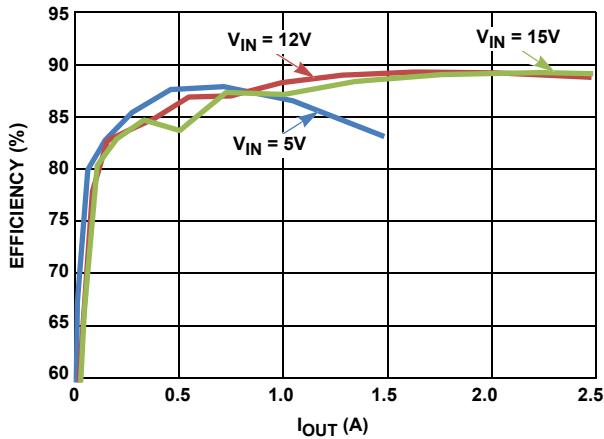

FIGURE 3. ISL85033-12VEVAL3Z EFFICIENCY: $V_{OUT} = -12V$

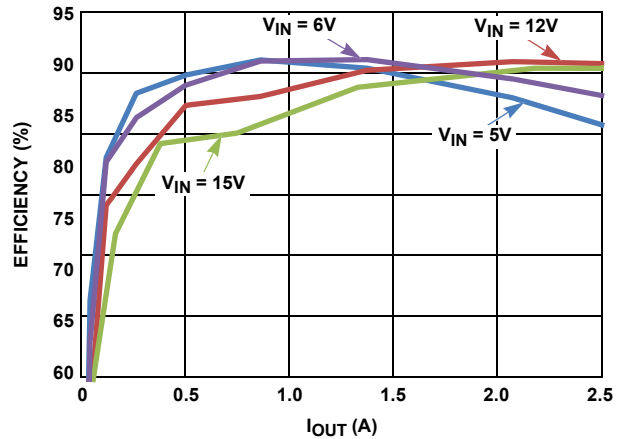

FIGURE 4. ISL85033-12VEVAL3Z EFFICIENCY: $V_{OUT} = -5V$

If the output voltage desired is $-0.8V$, then R3 is shorted. The value for R2 is typically between 1k and 10k. Note that if $V_{OUT} < |2.5V|$ (i.e., $-0.8V$), the switching frequency and compensation must be changed to accommodate the 300kHz operation, due to minimum on-time limitation. Please refer to the [ISL85033](#) data sheet for further information.

Frequency Control

The ISL85033-12VEVAL3Z evaluation board has an FS pin that controls the frequency of operation. Programmable frequency allows for optimization between efficiency and external component size. Default switching frequency is 500kHz when FS is tied to VCC ($R9 = 0$). By removing R9 and connecting R10 to the most negative potential on the board (V_{OUT}), the switching frequency could be changed from 300kHz ($R10 = 383k$) to 2MHz ($R10 = 40.2k$). See the [ISL85033](#) data sheet for information about calculating the value of R10. Do not leave this pin floating.

Disabling/Enabling Function

The ISL85033-12VEVAL3Z evaluation board contains an S1 switch that enables or disables both channels, thus allowing a low quiescent current state. Table 2 details this function.

TABLE 2. SWITCH SETTINGS

S1	ON/OFF CONTROL
ON	Enable V_{OUT}
OFF	Disable V_{OUT}

NOTE: If driven externally, the EN signal (the same as all input logic signals) is referenced to V_{OUT} (the most negative potential on the board) and not to GND. Therefore, the source cannot be GND referenced, and input level shifting is required.

ISL85033-12VEVAL3Z Schematic

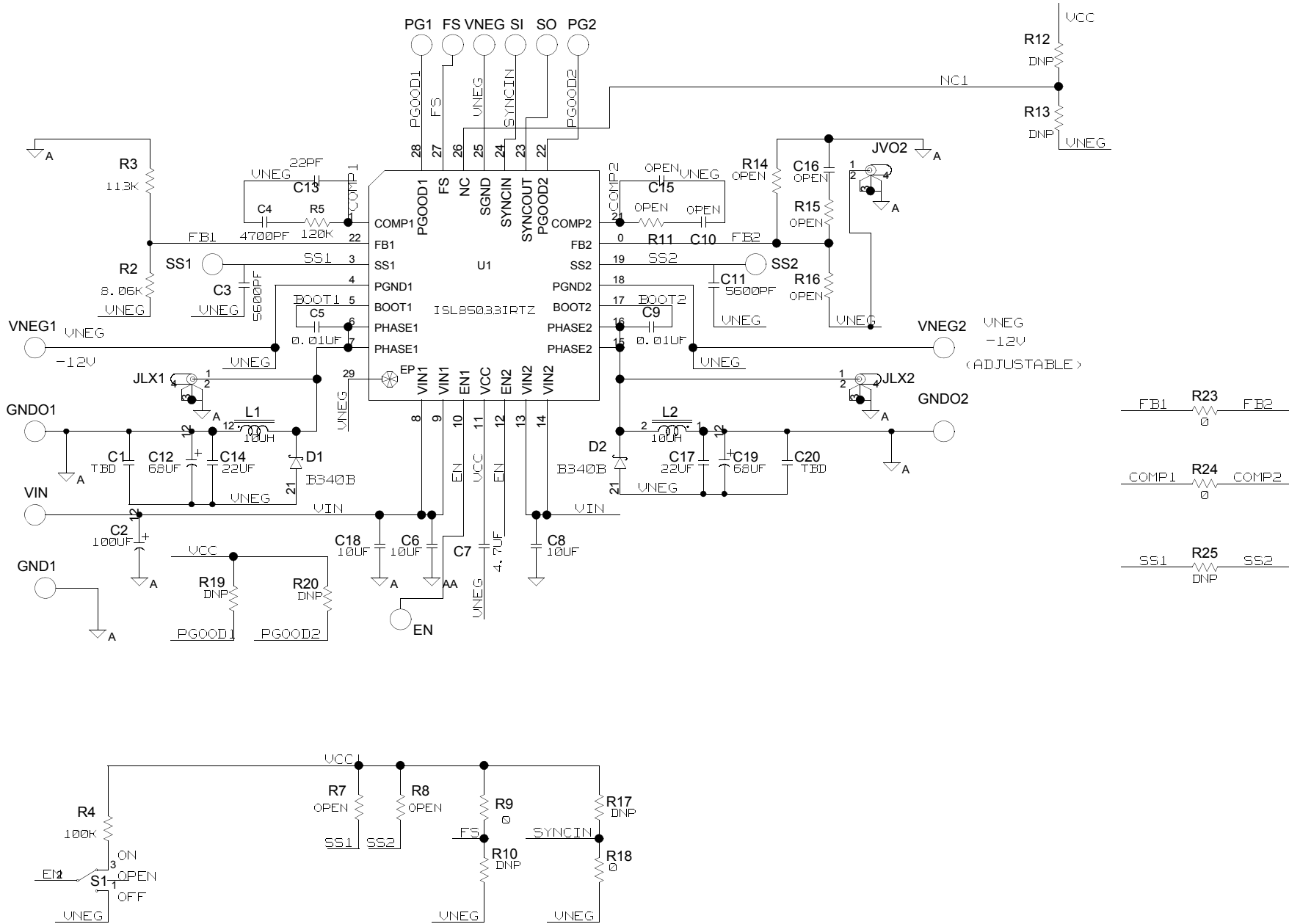

Bill of Materials

PART NUMBER	REFERENCE DESIGNATOR	QUANTITY	VALUE	TOLERANCE	VOLTAGE	POWER	PACKAGE TYPE	JEDEC TYPE	MANUFACTURER	DESCRIPTION
131-4353-00	JLX1, JLX2, JV02	3					CONN	TEK131-4353-00	TEKTRONIX	Scope Probe Test Point PCB Mount
TPSD686K020R00070-T	C12, C19	2	68 μ F	20%	20V		SMD	CAP_TANT	AVX	TQC Series Hi-Volt Low ESR Capacitor
B340B	D1, D2	2					SMD2	DO_SMA	DIODES	3A Low VF SCHOTTKY BARRIER RECTIFIER
C5750X7R1E226M	C14, C17	2	22 μ F	20%	25V		2220	CAP_2220	TDK	Ceramic Cap
EEE-FK1V101P-T	C2	1	100 μ F	20%	35V		SMD	CAPAE_315X402	PANASONIC	AL LYTIC FK SERIES CAP (RoHS COMP.)
GMK325BJ106KN	C6, C8	2	10 μ F	10%	35V		1210	CAP_1210	TAIYO YUDEN	Ceramic Chip Cap
GT13MCBE	S1	1					SW	SW_GT13MCBE	C&K	SPDT On-Off-On Ultraminiature Toggle Switch
H1044-00220-50V5	C13	1	22PF	5%	50V		402	CAP_0402	GENERIC	Multilayer Cap
H1044-00472-50V10	C4	1	4700PF	10%	50V		402	CAP_0402	GENERIC	Multilayer Cap
H1044-OPEN	C10, C15, C16	3	OPEN	OPEN	OPEN		402	CAP_0402	GENERIC	Multilayer Cap
H1045-00103-50V10	C5, C9	2	0.01 μ F	10%	50V		603	CAP_0603	GENERIC	Multilayer Cap
H1045-00562-50V10	C3, C11	2	5600PF	10%	50V		603	CAP_0603	GENERIC	Multilayer Cap
H1046-00475-10V20	C7	1	4.7 μ F	20%	10V		805	CAP_0805	GENERIC	Multilayer Cap
H1065-00106-25V10-T	C18	1	10 μ F	10%	25V		SMD	CAP_1206	VENKEL	Multilayer Cap
H1082-TBD-TBD	C1, C20	2	TBD	TBD	TBD		1210	CAP_1210	GENERIC	Ceramic Chip Cap
H2505-01003-1/16WR1	R4	1	100k	0.10%		1/16W	603	RES_0603	GENERIC	Metal Film Chip Resistor
H2505-DNP-DNP-1	R10, R17	2	DNP	1%		DNP	603	RES_0603	GENERIC	Metal Film Chip Resistor (Do Not Populate)
H2505-DNP-DNP-R1	R12, R13, R19, R20, R25	5	DNP	0.10%		DNP	603	RES_0603	GENERIC	Metal Film Chip Resistor (Do Not Populate)
H2510-01133-1/16W1	R3	1	113k	1%		1/16W	402	RES_0402	GENERIC	Thick Film Chip Resistor
H2510-01203-1/16W1	R5	1	120k	1%		1/16W	402	RES_0402	GENERIC	Thick Film Chip Resistor
H2510-08061-1/16W1	R2	1	8.06k	1%		1/16W	402	RES_0402	GENERIC	Thick Film Chip Resistor
H2510-ROPEN-OPEN	R7, R8, R11, R14-R16	6	OPEN	1%		OPEN	402	RES_0402	GENERIC	Thick Film Chip Resistor
H2511-00R00-1/16W	R23, R24	2	0	0%		1/16W	603	RES_0603	GENERIC	Thick Film Chip Resistor
H2511-00R00-1/16W1	R9, R18	2	0	1%		1/16W	603	RES_0603	GENERIC	Thick Film Chip Resistor
ISL85033IRTZ	U1	1					QFN	QFN28_157X157_157_EP	INTERSIL	WIDE VIN DUAL STANDARD BUCK REGULATOR (Pb-FREE)
PAD_100	EN, FS, SI, SO, PG1, PG2, SS1, SS2, VNEG	9					THOLE	PAD-100	GENERIC	0.100 Pad with 0.037 Plated Thru Hole

Bill of Materials (Continued)

PART NUMBER	REFERENCE DESIGNATOR	QUANTITY	VALUE	TOLERANCE	VOLTAGE	POWER	PACKAGE TYPE	JEDEC TYPE	MANUFACTURER	DESCRIPTION
PAD_150	VIN, GND1, GND01, GND02, VNEG1, VNEG2	6					THOLE	PAD-150	GENERIC	0.150 Pad with 0.110 Plated Thru Hole
SQ1004	L1, L2	2	10µH	25%		4.8A	SMD	IND_SQ10XX	FALCO	SMT SHIELDED POWER INDUCTOR

ISL85033-12VEVAL3Z Layout

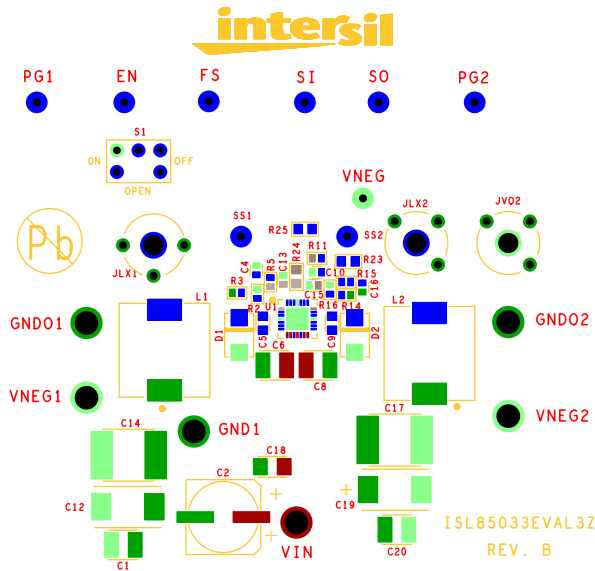

FIGURE 5. TOP LAYER COMPONENTS

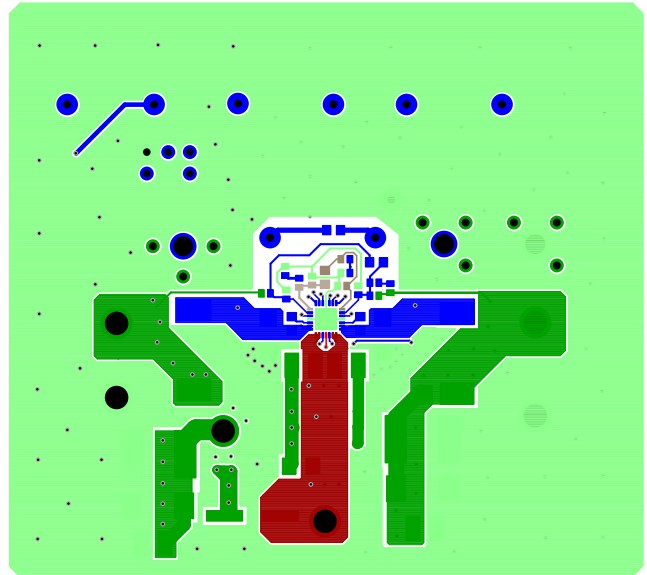

FIGURE 6. TOP LAYER ETCH

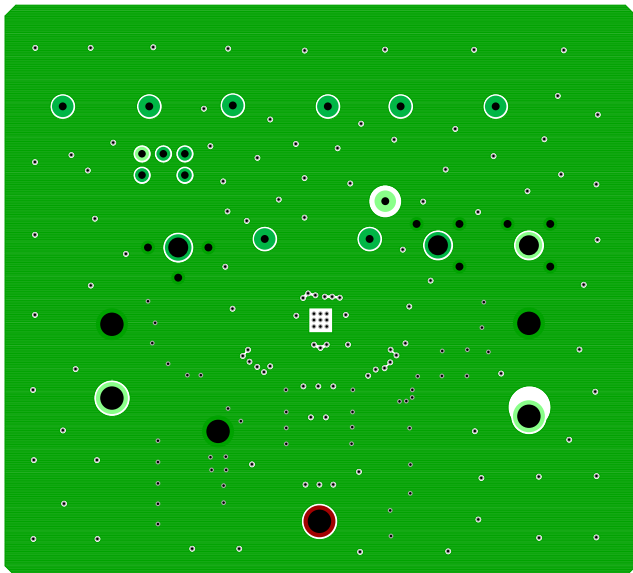

FIGURE 7. SECOND LAYER ETCH

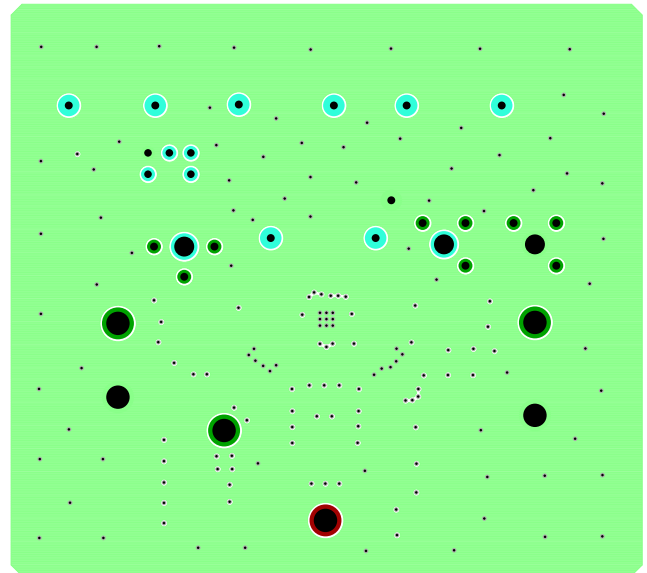

FIGURE 8. THIRD LAYER ETCH

ISL85033-12VEVAL3Z Layout (Continued)

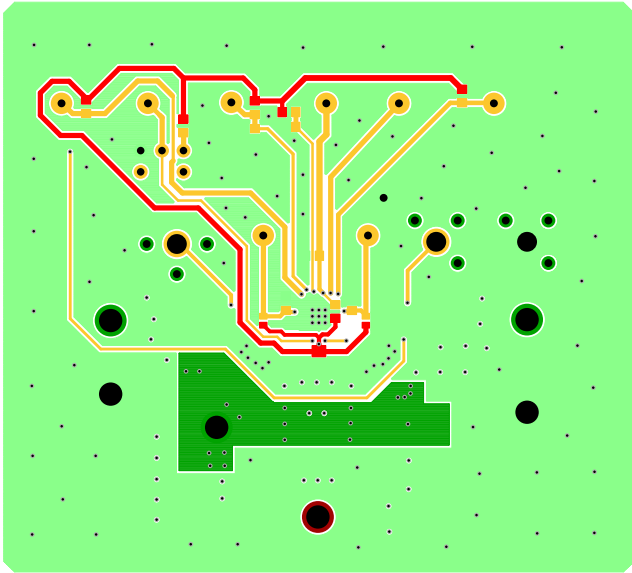

FIGURE 9. BOTTOM LAYER ETCH

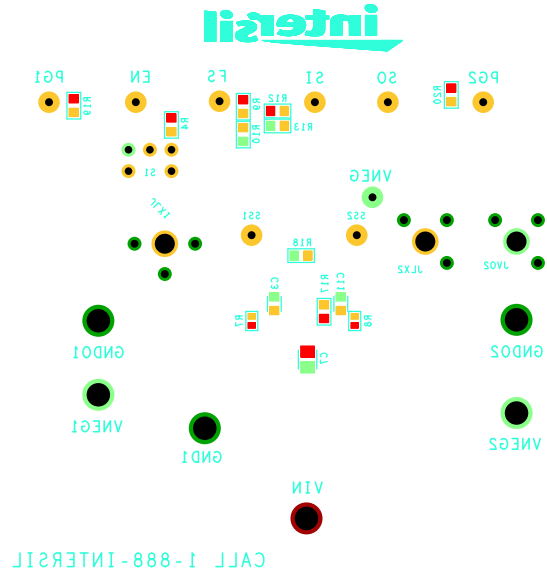

FIGURE 10. BOTTOM LAYER COMPONENTS

Notice

1. Descriptions of circuits, software and other related information in this document are provided only to illustrate the operation of semiconductor products and application examples. You are fully responsible for the incorporation or any other use of the circuits, software, and information in the design of your product or system. Renesas Electronics disclaims any and all liability for any losses and damages incurred by you or third parties arising from the use of these circuits, software, or information.
 2. Renesas Electronics hereby expressly disclaims any warranties against and liability for infringement or any other claims involving patents, copyrights, or other intellectual property rights of third parties, by or arising from the use of Renesas Electronics products or technical information described in this document, including but not limited to, the product data, drawings, charts, programs, algorithms, and application examples.
 3. No license, express, implied or otherwise, is granted hereby under any patents, copyrights or other intellectual property rights of Renesas Electronics or others.
 4. You shall not alter, modify, copy, or reverse engineer any Renesas Electronics product, whether in whole or in part. Renesas Electronics disclaims any and all liability for any losses or damages incurred by you or third parties arising from such alteration, modification, copying or reverse engineering.
 5. Renesas Electronics products are classified according to the following two quality grades: "Standard" and "High Quality". The intended applications for each Renesas Electronics product depends on the product's quality grade, as indicated below.
"Standard": Computers; office equipment; communications equipment; test and measurement equipment; audio and visual equipment; home electronic appliances; machine tools; personal electronic equipment; industrial robots; etc.
"High Quality": Transportation equipment (automobiles, trains, ships, etc.); traffic control (traffic lights); large-scale communication equipment; key financial terminal systems; safety control equipment; etc.
Unless expressly designated as a high reliability product or a product for harsh environments in a Renesas Electronics data sheet or other Renesas Electronics document, Renesas Electronics products are not intended or authorized for use in products or systems that may pose a direct threat to human life or bodily injury (artificial life support devices or systems; surgical implantations; etc.), or may cause serious property damage (space system; undersea repeaters; nuclear power control systems; aircraft control systems; key plant systems; military equipment; etc.). Renesas Electronics disclaims any and all liability for any damages or losses incurred by you or any third parties arising from the use of any Renesas Electronics product that is inconsistent with any Renesas Electronics data sheet, user's manual or other Renesas Electronics document.
 6. When using Renesas Electronics products, refer to the latest product information (data sheets, user's manuals, application notes, "General Notes for Handling and Using Semiconductor Devices" in the reliability handbook, etc.), and ensure that usage conditions are within the ranges specified by Renesas Electronics with respect to maximum ratings, operating power supply voltage range, heat dissipation characteristics, installation, etc. Renesas Electronics disclaims any and all liability for any malfunctions, failure or accident arising out of the use of Renesas Electronics products outside of such specified ranges.
 7. Although Renesas Electronics endeavors to improve the quality and reliability of Renesas Electronics products, semiconductor products have specific characteristics, such as the occurrence of failure at a certain rate and malfunctions under certain use conditions. Unless designated as a high reliability product or a product for harsh environments in a Renesas Electronics data sheet or other Renesas Electronics document, Renesas Electronics products are not subject to radiation resistance design. You are responsible for implementing safety measures to guard against the possibility of bodily injury, injury or damage caused by fire, and/or danger to the public in the event of a failure or malfunction of Renesas Electronics products, such as safety design for hardware and software, including but not limited to redundancy, fire control and malfunction prevention, appropriate treatment for aging degradation or any other appropriate measures. Because the evaluation of microcomputer software alone is very difficult and impractical, you are responsible for evaluating the safety of the final products or systems manufactured by you.
 8. Please contact a Renesas Electronics sales office for details as to environmental matters such as the environmental compatibility of each Renesas Electronics product. You are responsible for carefully and sufficiently investigating applicable laws and regulations that regulate the inclusion or use of controlled substances, including without limitation, the EU RoHS Directive, and using Renesas Electronics products in compliance with all these applicable laws and regulations. Renesas Electronics disclaims any and all liability for damages or losses occurring as a result of your noncompliance with applicable laws and regulations.
 9. Renesas Electronics products and technologies shall not be used for or incorporated into any products or systems whose manufacture, use, or sale is prohibited under any applicable domestic or foreign laws or regulations. You shall comply with any applicable export control laws and regulations promulgated and administered by the governments of any countries asserting jurisdiction over the parties or transactions.
 10. It is the responsibility of the buyer or distributor of Renesas Electronics products, or any other party who distributes, disposes of, or otherwise sells or transfers the product to a third party, to notify such third party in advance of the contents and conditions set forth in this document.
 11. This document shall not be reprinted, reproduced or duplicated in any form, in whole or in part, without prior written consent of Renesas Electronics.
 12. Please contact a Renesas Electronics sales office if you have any questions regarding the information contained in this document or Renesas Electronics products.
- (Note 1) "Renesas Electronics" as used in this document means Renesas Electronics Corporation and also includes its directly or indirectly controlled subsidiaries.
(Note 2) "Renesas Electronics product(s)" means any product developed or manufactured by or for Renesas Electronics.

(Rev.4.0-1 November 2017)



SALES OFFICES

Renesas Electronics Corporation

<http://www.renesas.com>

Refer to "<http://www.renesas.com/>" for the latest and detailed information.

Renesas Electronics America Inc.
1001 Murphy Ranch Road, Milpitas, CA 95035, U.S.A.
Tel: +1-408-432-8888, Fax: +1-408-434-5351

Renesas Electronics Canada Limited
9251 Yonge Street, Suite 8309 Richmond Hill, Ontario Canada L4C 9T3
Tel: +1-905-237-2004

Renesas Electronics Europe Limited
Dukes Meadow, Millboard Road, Bourne End, Buckinghamshire, SL8 5FH, U.K
Tel: +44-1628-651-700, Fax: +44-1628-651-804

Renesas Electronics Europe GmbH
Arcadiastrasse 10, 40472 Düsseldorf, Germany
Tel: +49-211-6503-0, Fax: +49-211-6503-1327

Renesas Electronics (China) Co., Ltd.
Room 1709 Quantum Plaza, No.27 ZhichunLu, Haidian District, Beijing, 100191 P. R. China
Tel: +86-10-8235-1155, Fax: +86-10-8235-7679

Renesas Electronics (Shanghai) Co., Ltd.
Unit 301, Tower A, Central Towers, 555 Langao Road, Putuo District, Shanghai, 200333 P. R. China
Tel: +86-21-2226-0888, Fax: +86-21-2226-0999

Renesas Electronics Hong Kong Limited
Unit 1601-1611, 16/F., Tower 2, Grand Century Place, 193 Prince Edward Road West, Mongkok, Kowloon, Hong Kong
Tel: +852-2265-6688, Fax: +852-2886-9022

Renesas Electronics Taiwan Co., Ltd.
13F, No. 363, Fu Shing North Road, Taipei 10543, Taiwan
Tel: +886-2-8175-9600, Fax: +886-2-8175-9670

Renesas Electronics Singapore Pte. Ltd.
80 Bendemeer Road, Unit #06-02 Hyflux Innovation Centre, Singapore 339949
Tel: +65-6213-0200, Fax: +65-6213-0300

Renesas Electronics Malaysia Sdn.Bhd.
Unit 1207, Block B, Menara Amcorp, Amcorp Trade Centre, No. 18, Jln Persiaran Barat, 46050 Petaling Jaya, Selangor Darul Ehsan, Malaysia
Tel: +60-3-7955-9390, Fax: +60-3-7955-9510

Renesas Electronics India Pvt. Ltd.
No.777C, 100 Feet Road, HAL 2nd Stage, Indiranagar, Bangalore 560 038, India
Tel: +91-80-67208700, Fax: +91-80-67208777

Renesas Electronics Korea Co., Ltd.
17F, KAMCO Yangjae Tower, 262, Gangnam-daero, Gangnam-gu, Seoul, 06265 Korea
Tel: +82-2-558-3737, Fax: +82-2-558-5338